

# GUIDE DE POSE AGENCEMENT SUR-MESURE

## MADE TO-MEASURE ARRANGEMENT GUIDE

INSTRUCTIONS DE MONTAGE  
ASSEMBLY INSTRUCTIONS



**ATTENTION ! :** les colonnes doivent être fixées à un mur ou à des meubles adjacents. /  
**CAUTION!:** columns must be fastened to a wall or to nearby pieces of furniture.



FR

ÉLÉMENTS D'EMBALLAGE  
À SÉPARER ET À DÉPOSER  
DANS LE BAC DE TRI



FR

Donnez ou recyclez  
vos meubles.



Association

ou



Magasin

ou



Déchèterie

<https://quefairedemesdechets.fr>

NOT\_0000593\_03

Mise à jour : Juin 2025 / Update : June 2025

**Versión en español**



**NOT\_00593\_ES.pdf**

## Chère cliente, cher client,

Vous venez d'acquérir votre nouvel agencement sur-mesure. Nous vous remercions de nous avoir fait confiance et espérons que celui-ci vous apportera tout le confort et toute la satisfaction que vous en attendez. Afin de vous aider à l'utiliser et à l'entretenir au mieux, nous avons réalisé ce guide, où sont réunies toutes les informations et les recommandations qui pourront vous être utiles pour la pose, le montage et l'entretien de votre nouvelle acquisition.

### Par où commencer ?

Que vous soyez nouveau dans la pose de meuble ou non, nous vous recommandons de **commencer votre lecture pages 4 et 5** afin de vous familiariser avec le fonctionnement de nos envois et de **bien préparer le début de votre pose.**

*Dear client,*

*You just acquired your new custom space. We thank you for your trust and hope it will enhance your experience and comfort as well as bring you the satisfaction you wished for. In order to help you maintain your new space, we created this guide compiling every information you might come to need: how to prepare your room, install your new furniture and most importantly, how to take care of it.*

### Where to start?

*Whether you are new to assembling your own furniture or a professional fitter, we recommend you **start reading on pages 4 and 5** in order to better understand how our process works and **properly organise the start of your installation.***



**Tous nos meubles sont fabriqués dans nos usines en Haute-Savoie**  
**All our furnitures are made in our factories in Haute-Savoie, France**

- ↳ Une main d'oeuvre qualifiée / *Qualified workforce*
- ↳ Un savoir-faire centenaire / *Century-old expertise*
- ↳ Une traçabilité claire et transparente / *Clear and transparent traceability*





# 1 GÉNÉRALITÉS ET INFORMATIONS / GENERAL INSTRUCTIONS AND INFORMATION

5

<b>A</b>	AVANT DE COMMENCER / BEFORE STARTING	5
<b>B</b>	UTILISATION DE LA NOTICE DE MONTAGE SPÉCIFIQUE ET DES ÉTIQUETTES / HOW TO USE THE ASSEMBLY GUIDE MAP AND ASSOCIATED TAGS	6
<b>C</b>	ENTRETIEN / MAINTENANCE	7
<b>D</b>	UTILISATION DES QUINCAILLERIES SI CAS SPÉCIFIQUES / USAGE OF HARDWARE IN SPECIFIC CASES	11

# 2 STRUCTURES / UNITS

12

<b>A</b>	MONTAGE DE COLONNE / UNIT ASSEMBLY	13
<b>B</b>	COLONNE D'ANGLE / CORNER UNIT	21
<b>C</b>	COLONNE SUSPENDUE / WALL UNIT	25

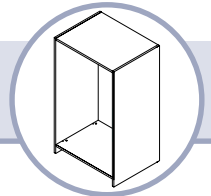

# 3 INTÉRIEURS / INTERIORS

30

<b>A</b>	SÉPARATION VERTICALE / VERTICAL SPACER	31
<b>B</b>	ÉTAGÈRE AMOVIBLE / ADJUSTABLE SHELF	32
<b>C</b>	ÉTAGÈRE VERRE / GLASS SHELF	33
<b>D</b>	BANDEAU DE RENFORT / SHELF REINFORCER	34
<b>E</b>	SPOT LED / LED SPOTS	35
<b>F</b>	PROFIL LED À ENCASTRER / SLOT-IN LED PROFILES	38
<b>G</b>	PENDERIE (AVEC OU SANS LED) / WARDROBE BAR (WITH OR WITHOUT LED PROFILES)	44

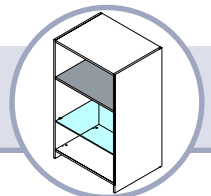

# 4 PANNEAUX ET FINITIONS / PANELS AND FINISHING TOUCHES

52

<b>A</b>	MASQUAGE DES PERÇAGES / DRILLS MASKING	53
<b>B</b>	FILLER / FILLER	54
<b>C</b>	SOCLE / PLINTH	57
<b>D</b>	PANNEAU DÉCO MIROIR / DECORATIVE MIRROR PANEL	58
<b>E</b>	PERÇAGES POUR POIGNÉES SUR CHANTS / DRILLINGS FOR HANDLES ON UNIT'S EDGES	61
<b>F</b>	TOUCHE-LÂCHE MANUEL POUR FAÇADES / MANUAL PUSH BUTTON FOR FACADES	62

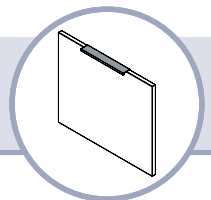

# 1

## GÉNÉRALITÉS ET INFORMATIONS GENERAL INSTRUCTIONS AND INFORMATION

### A AVANT DE COMMENCER / BEFORE STARTING

Protégez-vous : / Protect yourself:



#### 1 Libérer de l'espace dans les pièces pour le montage / Free space in the rooms for assembly

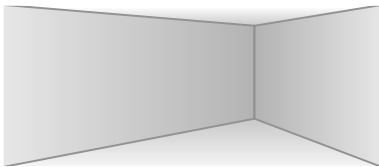

L'installation dans des murs en plaques de plâtre doit être conforme à la norme **NF DUT 24.41** / Installation in plasterboards must follow **NF DUT 24.41**.

La température doit être comprise entre **15° et 25°C.** / Temperature during assembly must be between **15° and 25°C.**

#### 2 Vérifier les colis à la réception / Check packages when you receive them

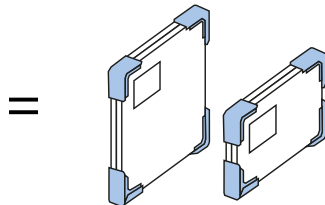
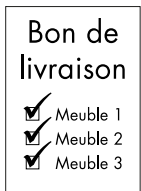

Groupes de panneaux / Panels groups

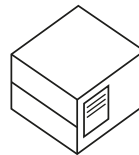

Cartons de quincailleries / Hardware cardboard boxes

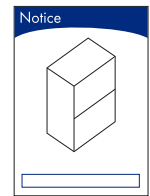

Notices / Assembly instructions

#### 3 Répartir les groupes de panneaux dans les pièces / Sort out each panels groups into its designated room

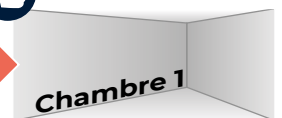
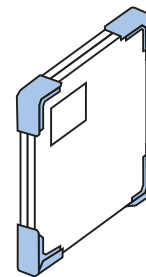
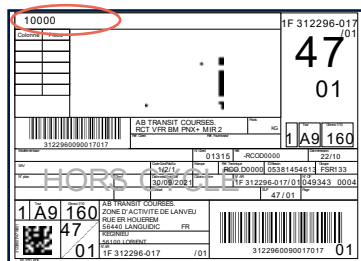
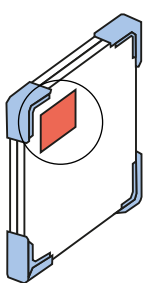

#### 4 Déballer et regrouper les éléments / Unpack and regroup each element

##### 1 Regrouper les panneaux par colonne / Regroup each panel by unit

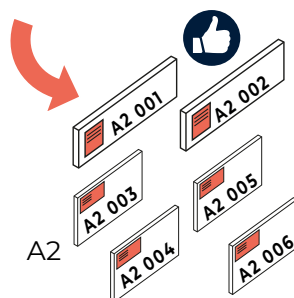
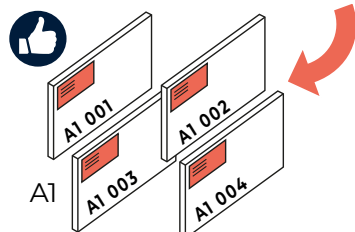
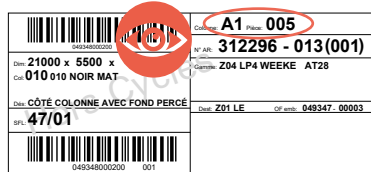
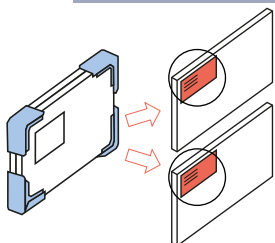

##### 2 Trier les quincailleries par type / Sort out the hardware by type

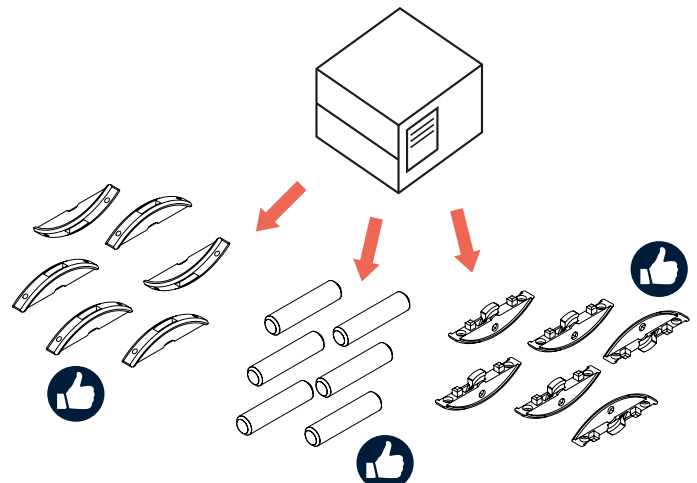

# B UTILISATION DE LA NOTICE DE MONTAGE SPÉCIFIQUE ET DES ÉTIQUETTES / HOW TO USE THE ASSEMBLY GUIDE MAP AND ASSOCIATED TAGS

**i**

Informations de commande / *Order information*

**1**

**NOTICE DE MONTAGE SPECIFIQUE**

**👁️**

Vue d'ensemble de la totalité du projet / *Project's complete view*

**👁️**

Vue 3D de l'ensemble du projet / *Project's complete 3D view*

**2**

Vue d'ensemble 3D

Vue d'ensemble dessus

Liste des ensembles

- Ensemble 2000 Salon
- Ensemble 2000 Chambre

**📄**

Liste des **ensembles** de meubles et localisation dans l'espace / *Sets listing and placement in the rooms*

**👁️**

Vue de **dessus** de l'ensemble du projet / *Project's complete top view*

**3**

<p><b>Ensemble 2000 avec façades</b></p>	<p>Détails avec façades</p>	<p><b>“Colonne”</b></p>
<p><b>Ensemble 2000 sans façades</b></p>	<p>Détails sans façades</p>	<p><b>“Place”</b></p>
<p><b>Ensemble 2000 vue de dessus</b></p>	<p>Notice de montage spécifique Affaire 4178795 Ensemble 2000 : Chambre</p>	
<p>Code Magasin : 01315</p>		<p>Numéro commande : 483801 Semaine de livraison : 28-2022</p>

**Etiquette panneaux / Panels sticker**

20000  
1F 312296-017  
47/01  
1A9160  
AB TRANSIT COURSES  
RUE DE LAUBERGERIE  
56440 LANGUEDIC  
FRANCE  
TF 312296-017

**Etiquette pièce / Part sticker**

Colonne **B3-021**  
N° AR **312296 - 013(001)**  
Gamme: Z04 LP4 WEEKE AT28  
21000 x 5500 x 180  
Col: 010 010 NOIR MAT  
Dés: CÔTÉ COLONNE AVEC FOND PERCÉ  
SFL: 47/01  
Dest: Z01 LE QF emb: 049347-00003

# C ENTRETIEN / MAINTENANCE

## 1 Règles d'or / Golden rules

### 1 Règles élémentaires / Basic rules

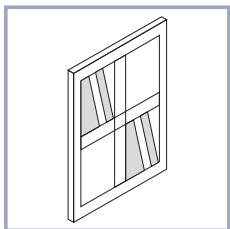

- 1 La pièce doit être ventilée et tempérée. / *The room must be ventilated and kept at an appropriate temperature.*
- 2 Les bouches d'aération de vos pièces ne doivent pas être obturées. / *Air vents in the rooms must not be obstructed.*
- 3 Les liquides doivent être immédiatement essuyés. / *Liquids must be wiped away immediately.*

### 2 Mises en garde / Precautions



→ Ne pas laisser couler ou stagner de liquide sur l'ensemble des matériaux et **sécher immédiatement.** / *Do not allow liquids to run over or stagnate on any materials and **dry them immediately.***



→ Ne pas utiliser de corrosifs, abrasifs ou acides sur votre aménagement. / *Do not use corrosive, abrasive or acidic products on your units.*



→ Ne pas sécher de torchons ou serviettes contre les façades. / *Do not dry clothes on front panels or doors.*



→ Ne pas exposer les matériaux à la vapeur. / *Do not expose materials to steam.*

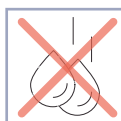

→ Ne pas nettoyer à grandes eaux ou avec des appareils vapeur. / *Do not wash any part of your units with large amounts of water or steam devices.*

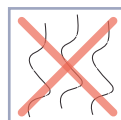

→ Ne pas exposer à de fortes chaleur vos plans de travail. / *Do not expose your workshop to excessive heat.*



→ Ne pas surcharger les tiroirs, coulissants ou étagères. / *Do not overload drawers, sliding drawers or shelves.*

## 2 Tout savoir sur l'entretien / All about maintenance

### 1 Entretien des façades et portes / Doors and cladding materials maintenance

- 1 La plupart des éléments se nettoient à l'eau et au savon ou produit à vitre (de préférence sans alcool) avec un chiffon microfibre bien essoré. / *Most components can be cleaned with soap or glass cleaner (preferably alcohol-free) and water using a well-wrung cloth.*
- 2 Sécher immédiatement avec un chiffon sec. / *Immediately dry with a dry cloth.*
- ! **Proscrire absolument l'utilisation d'éponges abrasives ou de crèmes à récurer.** / ***Never use abrasive sponges or scouring creams.***

### 2 Entretien des stratifiés et stratifiés LUXE / Laminate and LUXE laminate maintenance



→ Utiliser une éponge légèrement humide (essorée) avec une eau savonneuse puis essuyer avec un chiffon sec, une microfibre humide et un produit à vitre ou un rénovateur de stratifié (Réf : MRES). / *Use a slightly moist (wrung-out) sponge with soapy water, then wipe with a dry cloth, a moist microfibre cloth and a glass cleaner or a laminate rejuvenator (Ref: MRES).*



→ Pour retirer les traces de calcaire : utiliser du vinaigre blanc en petite quantité. Bien rincer à l'eau claire puis sécher immédiatement à l'aide d'un chiffon sec ou d'un tissu microfibrés humide. / *Scale removal: white vinegar, rinse, wipe.*

### 3 Entretien des bois / Wood maintenance



- 1 Huiler très régulièrement : 1 fois par mois avec l'huile Ref : HUILEPT ou Ref : HUILOS. / Oil very regularly: once a month, with the oil Ref: HUILEPT or Ref: HUILOS.

- 2 Utiliser une éponge légèrement humide (essorée) avec une eau savonneuse puis essuyer avec un chiffon sec. / Use a slightly moist (wrung dry and squeezed out) sponge with soapy water, then wipe with a dry cloth.

- 3 Le bois est un matériau naturel, il s'altère au contact de l'eau, des acides, javel, alcool, détergents, dégraissant, bicarbonate, citron, vinaigre, colorant alimentaire, épices, etc. / Wood is a natural material which alters in contact with water, acid, bleach, alcohol, detergents, degreasers, bicarbonate, lemon, vinegar, food colourings or spices, etc.

- 4 Le bois est une matière vivante qui travaille selon les variations climatiques : des fentes et des déformations peuvent apparaître (une température et un taux d'humidité relativement stables limitent ces désagréments). / Wood is a natural material which changes according to climatic variations: cracks and deformities may appear (more stable temperatures and moisture levels will minimise these changes).

- 5 Son vieillissement est tout à fait naturel, les bois clairs ont tendance à foncer et les foncés à éclaircir. / It is entirely natural for it to age: light wood tends to darken and dark wood can lighten.

### 4 Entretien des matériaux synthétiques / Synthetic materials maintenance



- 1 Utiliser une éponge humide (essorée) avec de l'eau savonneuse ou mélangée avec du dégraissant pour nettoyer, puis sécher avec un chiffon sec ou un tissu microfibrés humide. Un produit d'entretien pour vitre peut aussi convenir. / Use a slightly moist (wrung dry and squeezed out) sponge with soapy water or degreaser, then wipe with a dry cloth or moist microfibre cloth. A glass cleaning product may also be suitable.

- 2 Pour retirer les traces de calcaire : utiliser du vinaigre blanc en petite quantité. Bien rincer à l'eau claire puis sécher immédiatement à l'aide d'un chiffon sec ou d'un tissu microfibrés humide. / Scale removal: white vinegar, rinse, wipe.

### 5 Entretien des matériaux inox / Stainless steel maintenance

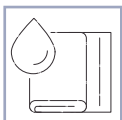

Utiliser un tissu microfibrés humide et du nettoyant pour vitre ou le spray nettoyant (REF. MREI). N'utiliser jamais de l'ammoniac, de chlore ou tout autre produit corrosif. Pour réduire les marques d'empreintes digitales après le nettoyage, tremper un tissu d'alcool dénaturé et appliquer une fine couche sur la surface sans la retirer ou la rincer (les empreintes seront moins visibles et le nettoyage plus facile la fois d'après). /

Use a moist microfibre cloth and a glass cleaner or the cleaning spray (Ref. MREI). Never use ammonia, chlorine or any other corrosive product. To reduce sensitivity to fingerprints after cleaning, soak a cloth with methylated spirits and apply a fine layer onto the surface without wiping it off (fingerprints will be less visible and cleaning will be easier next time).

#### **IMPORTANT / IMPORTANT** Pour toute les matières et produits utilisés : / For all materials and products used:

- ! Nous recommandons l'utilisation de chiffon doux microfibrés. / We recommend the use of a soft microfibre cloth.
- ! Rincez toujours à l'eau claire avec un chiffon microfibre humide pour essuyer. / Always rinse with clean water using a moist microfibre cloth, then wipe.
- ! Nous recommandons l'eau écarlate pour faire disparaître les traces de colle, étiquettes et résidus de film transparent. / We recommend Eau Écarlate for removing traces of glue, labels and clear film residue.
- ! N'utilisez pas de détergents trop abrasifs ou corrosifs contenant des particules abrasives ou le côté récurant de l'éponge et éviter le contact avec des solvants, dissolvants, décapants et produits chimiques très agressifs. / Do not use excessively corrosive or abrasive detergents containing abrasive particles or the scouring side of the sponge, and avoid contact with solvents, dissolvents, strippers and highly aggressive chemical products.

## 6 Entretien des composants / Components maintenance

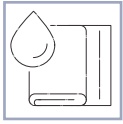

→ Utiliser une microfibre légèrement humide avec un produit à vitre puis sécher immédiatement avec un chiffon sec. / Use a slightly moist microfibre cloth with a glass cleaner, then dry immediately with a dry cloth.

→ Ne pas laisser stagner l'eau ou autre liquide au fond des tiroirs. / Do not allow water or other liquids to stagnate at the bottom of drawers.



Pas d'entretien ni graissage nécessaire mais des réglages sont recommandés pour la durabilité des portes. / No maintenance or greasing necessary, but adjustments are recommended for durability of doors.



Utiliser uniquement une microfibre légèrement humide avec un produit à vitre puis sécher immédiatement avec un chiffon sec. / Use a slightly moist microfibre cloth with a glass cleaner, then dry immediately with a dry cloth.

## 7 Entretien des équipements / Equipment and fittings maintenance

### TAPIS DE TIROIRS / DRAWER MATS

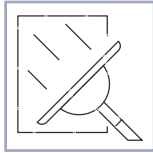

### MATIÈRES PLASTIQUES, INOX ET ALU / PLASTIC, STAINLESS STEEL AND ALUMINIUM ACCESSORIES

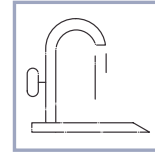
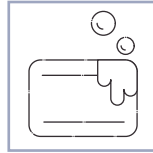

Nettoyer **avec une éponge imprégnée d'une eau additionnée d'un produit d'entretien** puis rincer et essuyer avec un chiffon sec. / Clean with **a sponge soaked in water mixed with a maintenance product**, then rinse and wipe with a dry cloth.

## 3 Prévention et sécurité / Preventive measures and safety

### GESTES PRÉVENTIFS / PREVENTIVE MEASURES

- Débranchez les appareils électriques. / Disconnect electrical appliances.
- Rangez tous les objets coupants dans un même endroit inaccessible pour les enfants. / Store all sharp objects in one place inaccessible to children.
- Rangez allumettes et briquets hors de portée des enfants. / Store matches and lighters out of children reach.

- Ayez sous la main les numéros d'urgences téléphoniques (pompiers : 18 - SAMU : 15 - Centre antipoison de votre secteur d'habitation). / Keep emergency telephone numbers at hand: 999 for the fire brigade or ambulance depending on your country of residence.



TOXIQUE / TOXIC

#### À FAIRE / DO

- Eloignez toute flamme ou fumée lors de la phase de nettoyage ainsi qu'à proximité de la zone de stockage. / Avoid nearby flames or smoke during the cleaning process or within proximity of the storage area.
- Portez des gants pour les manipuler. / Wear gloves when handling.



NOCIF / HARMFUL



INFLAMMABLE / FLAMMABLE

#### À NE PAS FAIRE / DON'T

- Ne les laissez pas à la portée des enfants. / Do not leave within reach of children.
- Ne les respirez pas. / Do not inhale.

MATÉRIAUX / MATERIALS	MARQUES / MARKS	LIQUIDE VAISSELLE (DÉGRAISSANT DOUX) / WASH-UP LIQUID (GENTLE DEGREASING)	PRODUIT À VITRE / GLASS CLEANER	PRODUITS SPÉCIFIQUES / SPECIAL PRODUCTS	PRODUITS SPÉCIFIQUES ÉQUIPEMENTS / SPECIAL FITTINGS & EQUIPMENTS	INFORMATIONS COMPLÉMENTAIRES / ADDITIONAL INFORMATION
<b>MÉLAMINÉ / MELAMINE</b>	Gras / Grease	☺	☺		RÉF.MRES	PAS D'ALCOOL SUR LES TÂCHES D'ENCRE / NO ALCOHOL ON INK STAINS
	Calcaire / Scaling			VINAIGRE BLANC / WHITE VINEGAR		
	Colle / Glue			EAU ÉCARLATE	RÉF.MRES	
	Divers / Scratches			ALCOOL MÉNAGER / RUBBING ALCOHOL	RÉF. KP	
<b>MÉLAMINÉ VERNI / VARNISHED MELAMINE</b>	Gras / Grease	☺	☺		RÉF.MRES	
	Calcaire / Scaling			VINAIGRE BLANC / WHITE VINEGAR		
	Colle / Glue			EAU ÉCARLATE		
	Divers / Scratches				RÉF. KP	
<b>STRATIFIÉ LUXE / LUXE LAMINATE</b>	Gras / Grease	☺	☺		RÉF.MRES	BIEN RINCER ET ESSUYER IMMÉDIATEMENT LES PROJECTIONS ÉVENTUELLES DE PRODUITS ANTI-CALCAIRE UTILISÉS POUR LE SANITAIRE / RINSE WELL AND IMMEDIATELY WIPE AWAY ANY SPLASHES OF ANTI-SCALE PRODUCTS USED FOR SANITARY PURPOSES
	Calcaire / Scaling			VINAIGRE BLANC / WHITE VINEGAR		
	Colle / Glue			EAU ÉCARLATE		
	Divers / Scratches			ACÉTONE / ALCOOL MÉNAGER / RUBBING ALCOHOL		
<b>STRATIFIÉ LUXE FÉNIX / LUXE FÉNIX LAMINATE</b>	Gras / Grease	☺	☺			BIEN RINCER ET ESSUYER IMMÉDIATEMENT LES PROJECTIONS ÉVENTUELLES DE PRODUITS ANTI-CALCAIRE UTILISÉS POUR LE SANITAIRE / RINSE WELL AND IMMEDIATELY WIPE AWAY ANY SPLASHES OF ANTI-SCALE PRODUCTS USED FOR SANITARY PURPOSES
	Calcaire / Scaling			VINAIGRE BLANC / WHITE VINEGAR		
	Colle / Glue			EAU ÉCARLATE		
	Divers / Scratches				MICRO-RAYURES RÉPARABLES AVEC UN FER À REPASSER ET UN LINGE MOUILLÉ / MICRO-SCRATCHES CAN BE REPAIRED WITH AN IRON AND A DAMP CLOTH	
<b>LAQUE SATINÉ &amp; BRILLANTE / SATIN &amp; GLOSSY LACQUER</b>	Gras / Grease	☺	☺		RÉF.MRES	UTILISER DU COTON HYDROPHILE SANS APPUYER NI INSISTER / USE COTTON WOOL, WITHOUT PRESSING OR OVERDOING IT
	Calcaire / Scaling			VINAIGRE BLANC / WHITE VINEGAR		
	Colle / Glue			EAU ÉCARLATE	RÉF.MRES	
	Divers / Scratches			ALCOOL MÉNAGER / RUBBING ALCOHOL	RÉF. KP	
<b>BOIS &amp; BOIS LAQUÉ / WOOD &amp; LACQUERED WOOD</b>	Gras / Grease	☺	☺			PLAN DE TRAVAIL : HUILER TRÈS RÉGULIÈREMENT / WORKTOP: OIL VERY REGULARLY
	Calcaire / Scaling					
	Colle / Glue			EAU ÉCARLATE		
	Divers / Scratches				RÉF. HUILEPT/HUILOS	
<b>VERRE / GLASS</b>	Gras / Grease	☺	☺			
	Calcaire / Scaling					
	Colle / Glue			EAU ÉCARLATE / ACÉTONE		
	Divers / Scratches			ACÉTONE / ALCOOL MÉNAGER / RUBBING ALCOHOL		
<b>INOX / STAINLESS STEEL</b>	Gras / Grease	☺			RÉF.MREI	NE PAS UTILISER DE CHLORE OU DE JAVEL / DO NOT USE CHLORINE OR BLEACH
	Calcaire / Scaling			VINAIGRE BLANC / WHITE VINEGAR		
	Colle / Glue			EAU ÉCARLATE		
	Divers / Scratches			ALCOOL MÉNAGER / RUBBING ALCOHOL		

# D UTILISATION DES QUINCAILLERIES SI CAS SPÉCIFIQUES / USAGE OF HARDWARE IN SPECIFIC CASES

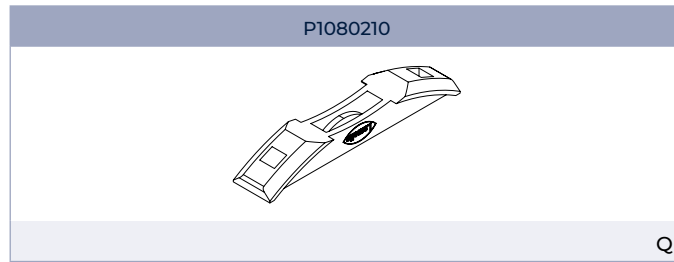

## **i** Cas 1 : étagères face à face dans une colonne / Case 1: shelves facing each other through the unit

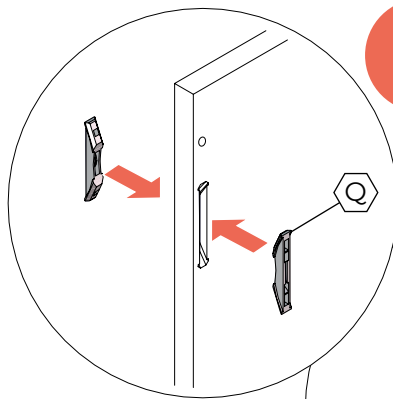
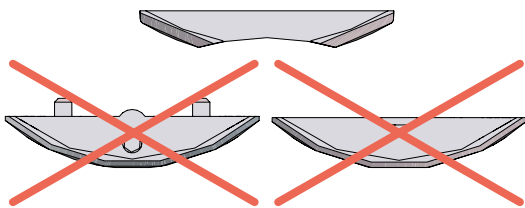
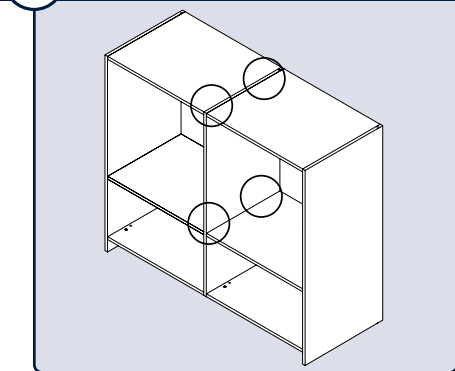

L'emplacement inversé des zones de fixations des tourillons et des assembleurs (Q) n'a pas d'incidence sur le montage du produit / The reverse location of the fixing areas of the trunnions and assemblers (Q) has no impact on the assembly of the product

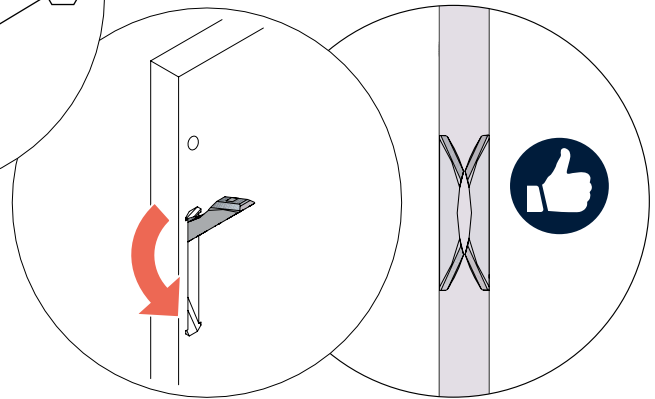

## **i** Cas 2 : passage d'un câble électrique / Case 1: electrical cable slot

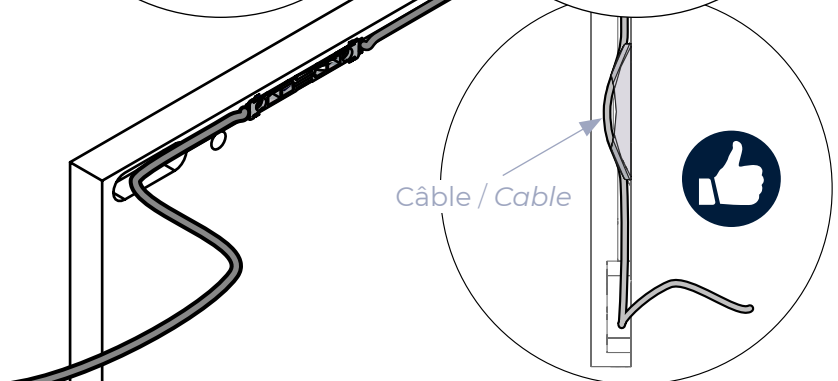
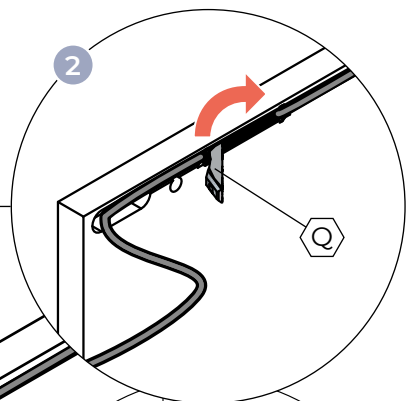
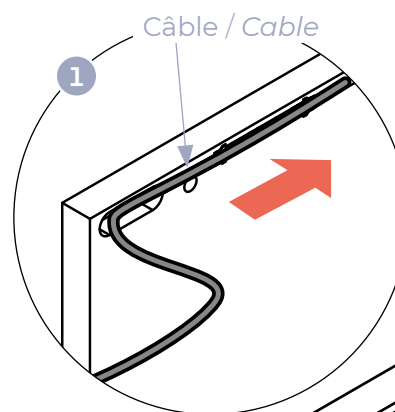
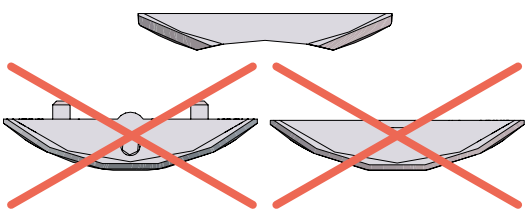
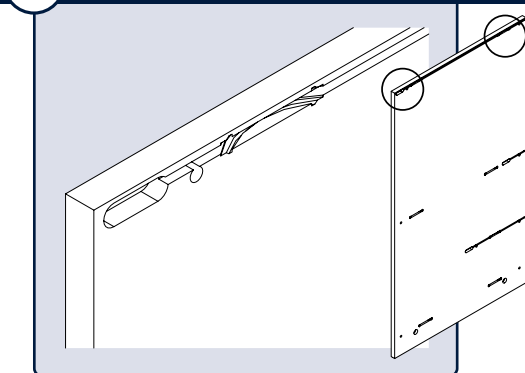

# 2

## STRUCTURES UNITS

### A MONTAGE DE COLONNE / UNIT ASSEMBLY

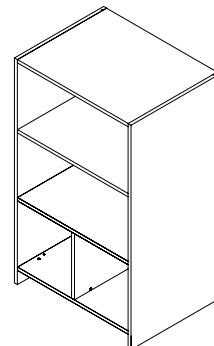

13

### B RETOUR D'ANGLE / CORNER

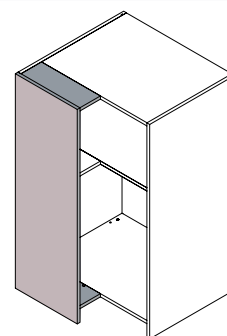

21

### C COLONNE SUSPENDUE / WALL UNIT

Le montage est le même que la colonne classique / Assembly is the same as regular unit



Collage obligatoire des tourillons si colonne suspendue / Mandatory gluing of trunnion if wall unit

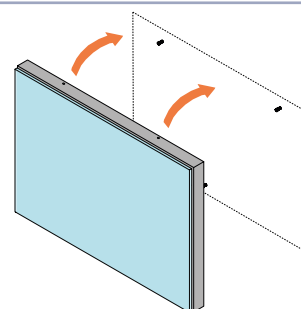

25



Les positionnements et configurations sont un exemple de cas (les positionnements peuvent varier) /  
The placements and configurations shown here are an example (positionings may vary)

#### OUTILLAGE NON FOURNI / NOT SUPPLIED

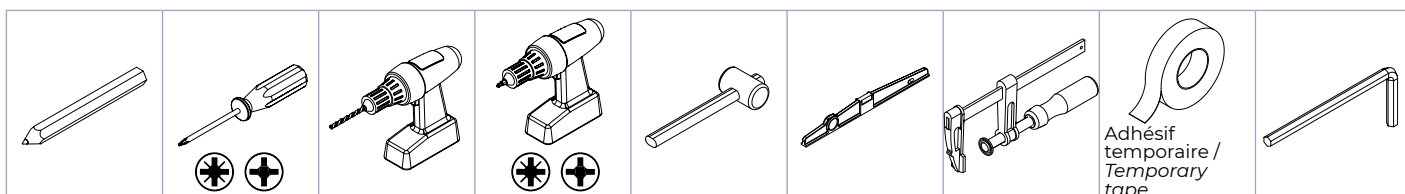

# A MONTAGE DE COLONNE / UNIT ASSEMBLY

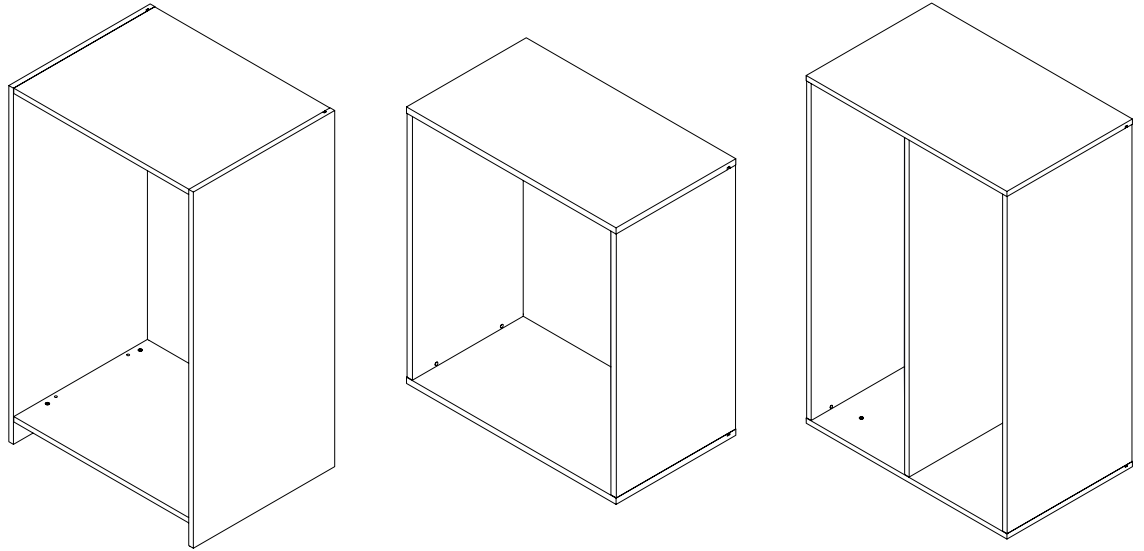

## QUINCAILLERIE / HARDWARE

P1080208	P1080209	P29449600	P31018601	P31018700	P31018900	P31000364	P31000488	P41000059
A	B	C	75mm D	100mm D	170mm D	Ø12/7,5x35 E	F	G
P31019100	CTA20	CTA13	CTA09					
H	Ø20	I Ø13	J Ø9	K				

Si colonne suspendue : / If hanging unit:				
P31010725	P31010726	RAILSUS	P29452900	P31000368
L	M	N	Ø4x16 O	P

Cas spécifiques (face à face d'étagères ou câble électrique) : / Specific cases (shelves facing each other or electrical cable)

P1080210

Q

1	Côté initial / <i>Initial side panel</i>	6	Etagère sur niche / <i>Superior open shelf</i>
2	Plafond / <i>Top</i>	7	Niche / <i>Open shelf (niche)</i>
3	Fond / <i>Bottom</i>	8	Etagère sous niche / <i>Inferior open shelf</i>
4	Dos / <i>Back</i>	9	Séparateur vertical / <i>Vertical spacer</i>
5	Etagère de structure / <i>Structural shelf</i>	10	Côté final / <i>Final side panel</i>
5'	Etagère entre dos / <i>In-between back shelf</i>		



Ces positionnements et configurations sont un exemple de cas (les positionnements peuvent varier) /

*The placements and configurations shown here are an example (positionings may vary)*

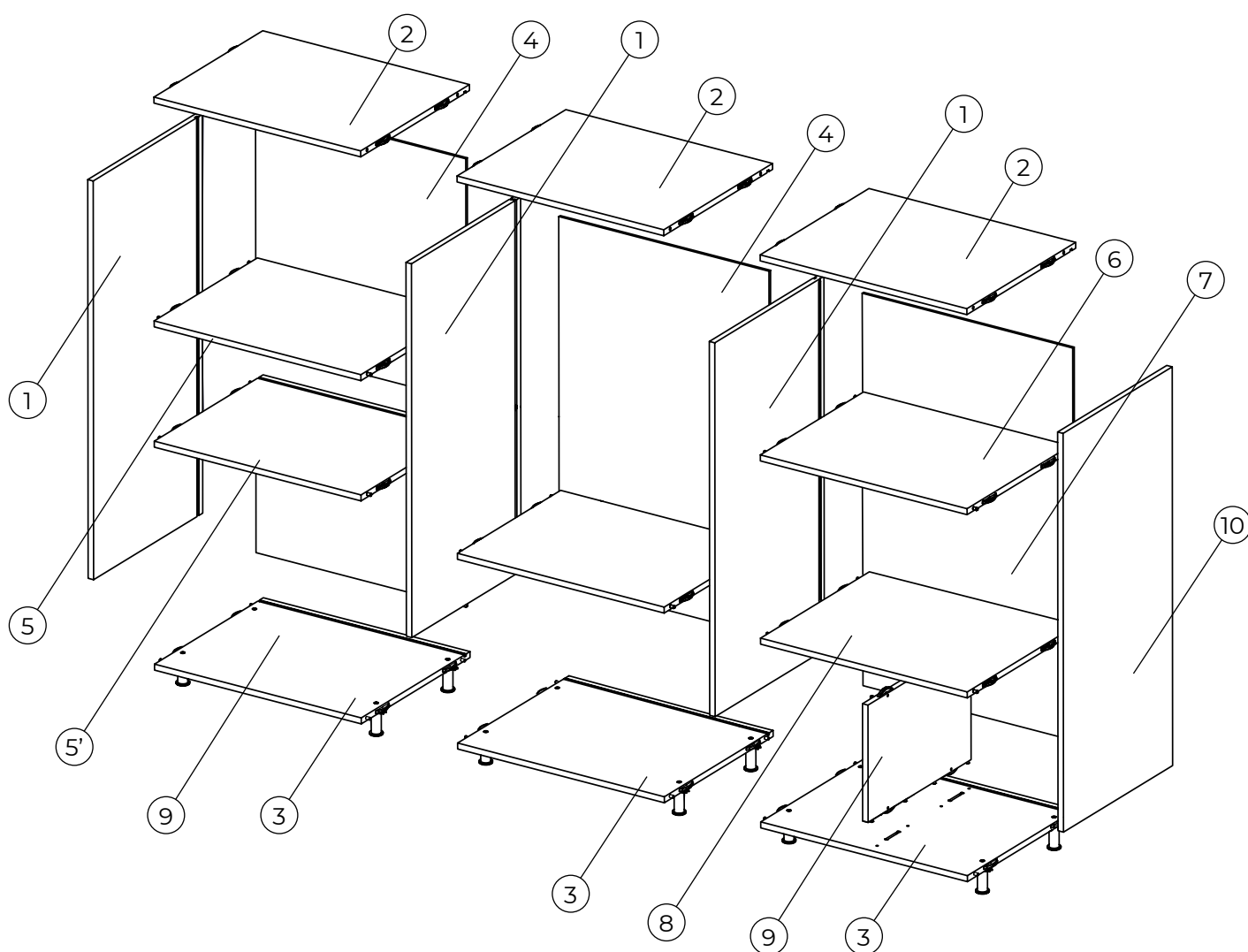

Tous les côtés à part le dernier sont des « Côtés initiaux » / *All side panels except the final one are called « Initial side panels »*

**1** Préparation des côtés / *Side panels preparation*

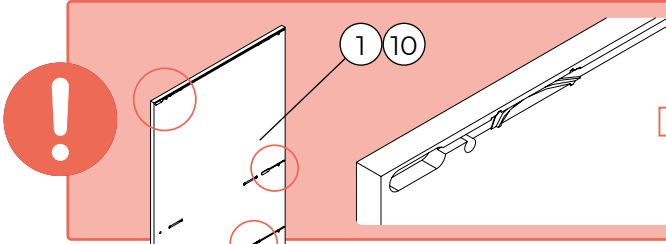

! 1 10

Chapitre 3 : Intérieurs / *Chapter 3: Interiors*

p.30

p.46

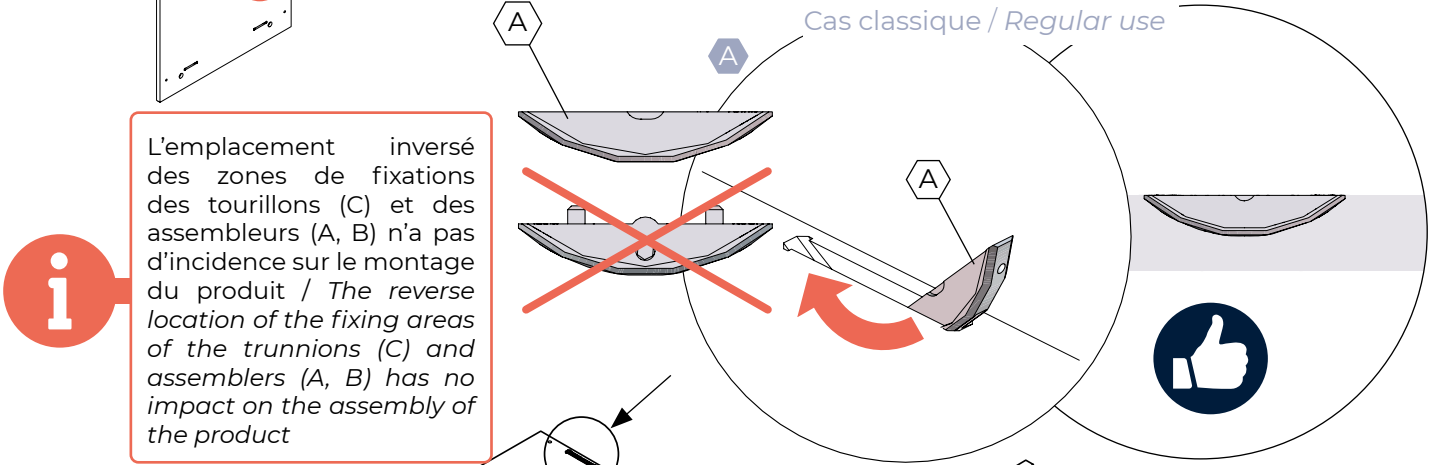

**i** L'emplacement inversé des zones de fixations des tourillons (C) et des assembleurs (A, B) n'a pas d'incidence sur le montage du produit / *The reverse location of the fixing areas of the trunnions (C) and assemblers (A, B) has no impact on the assembly of the product*

Cas classique / *Regular use*

Thumbs up icon

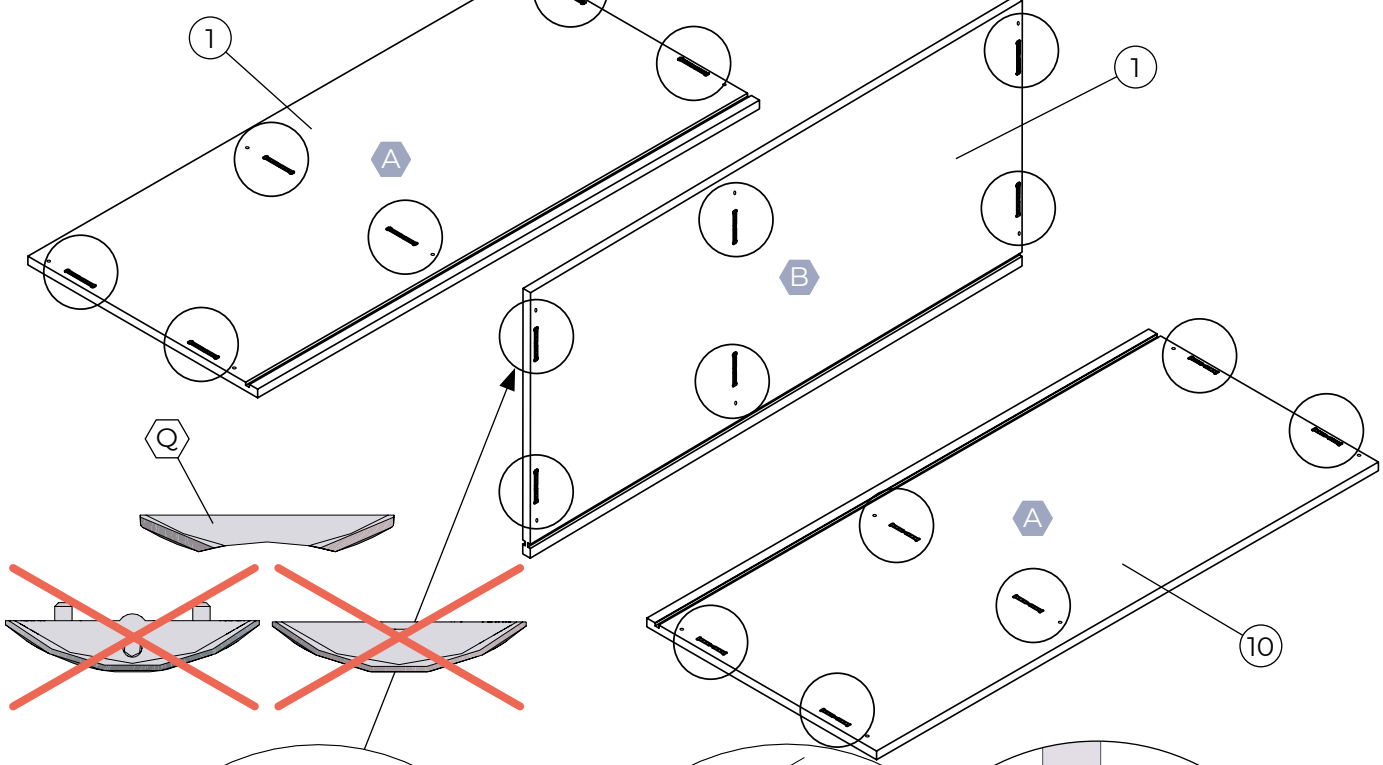
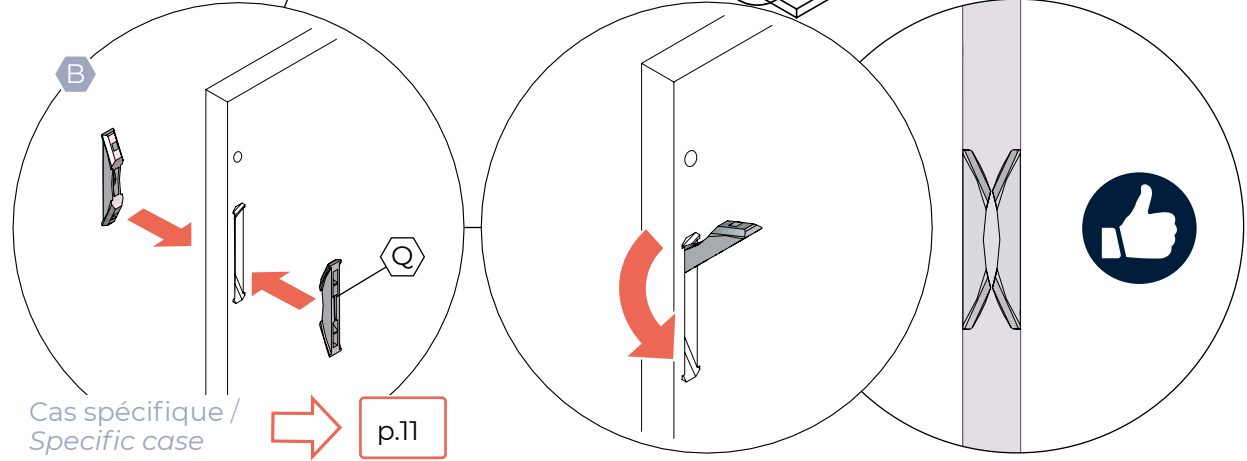
**B** **Q**

Cas spécifique / *Specific case*

p.11

Thumbs up icon

## 2 Préparation des fonds, plafonds, étagères et niches / Bottoms, tops and shelves preparation



L'emplacement inversé des zones de fixations des tourillons (C) et des assembleurs (A, B) n'a pas d'incidence sur le montage du produit / The reverse location of the fixing areas of the trunnions (C) and assemblers (A, B) has no impact on the assembly of the product

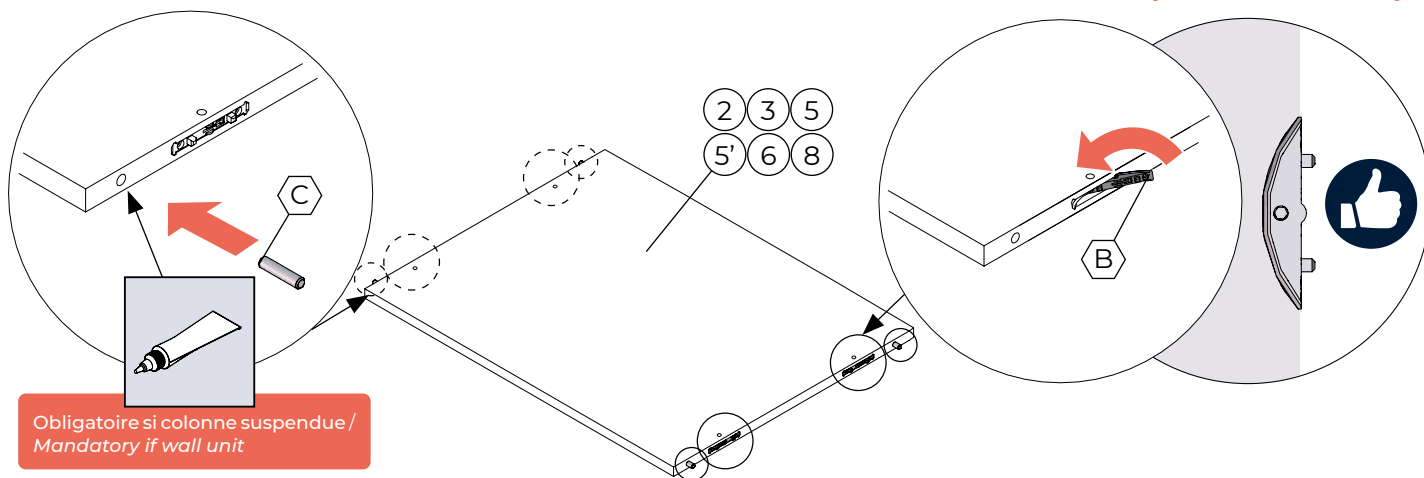
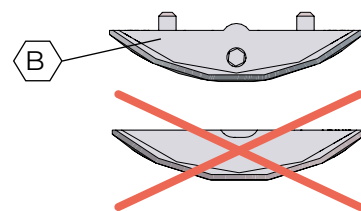

## 3 Si besoin : préparation des séparations verticales / If needed : vertical spacer preparation

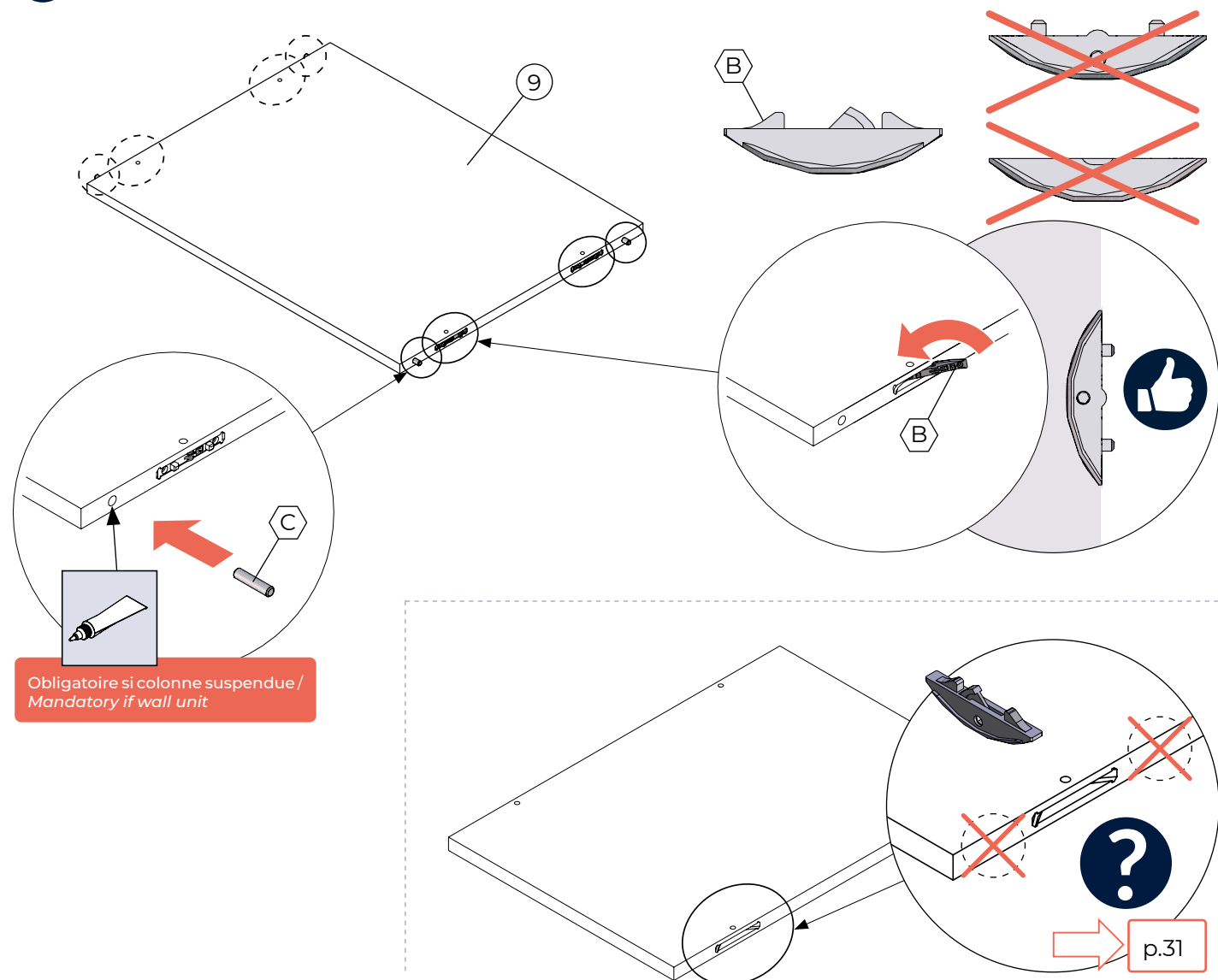

**4** Si besoin : préparation des pieds / *If needed : legs preparation*

**i** Pieds hauts à visser / *To be screwed high legs*

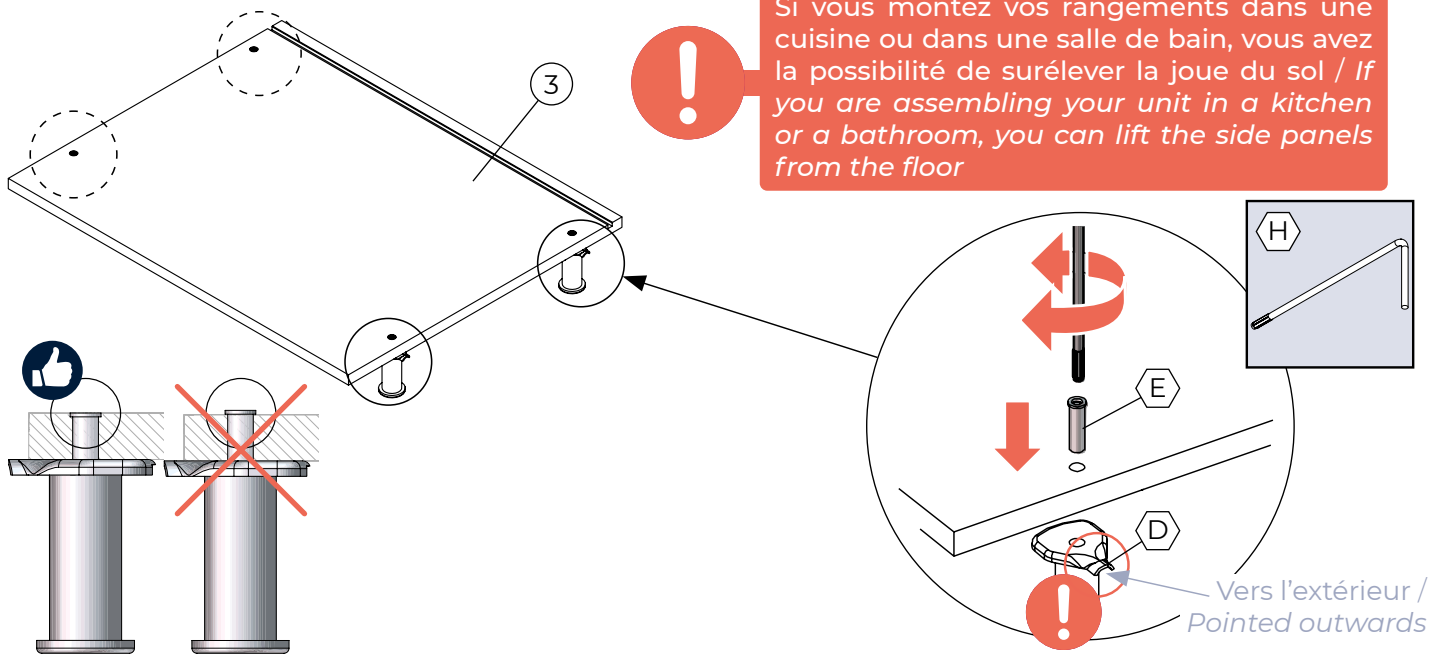

**i** Pieds encastrés / *Embedded legs*

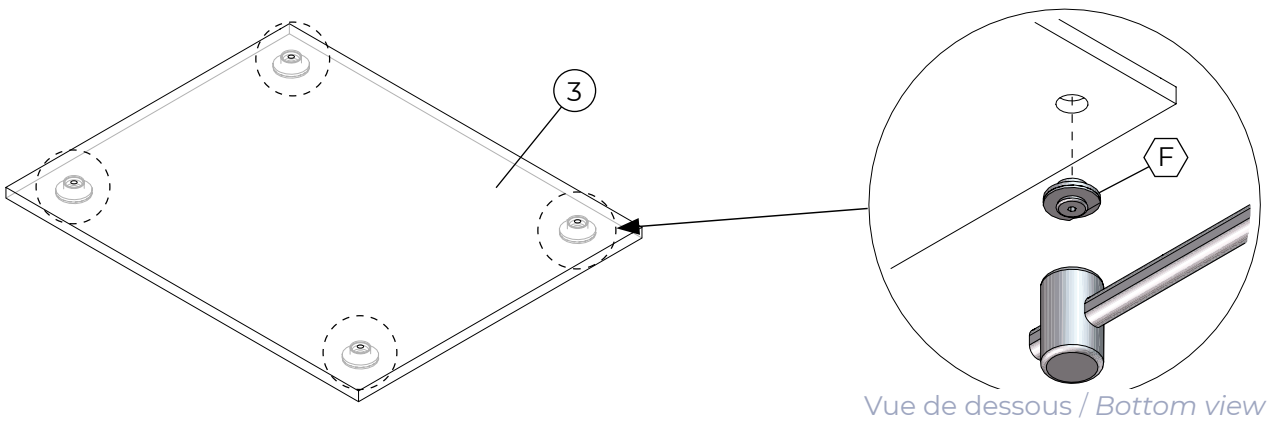

**i** Pieds sur côté / *Legs on side panel*

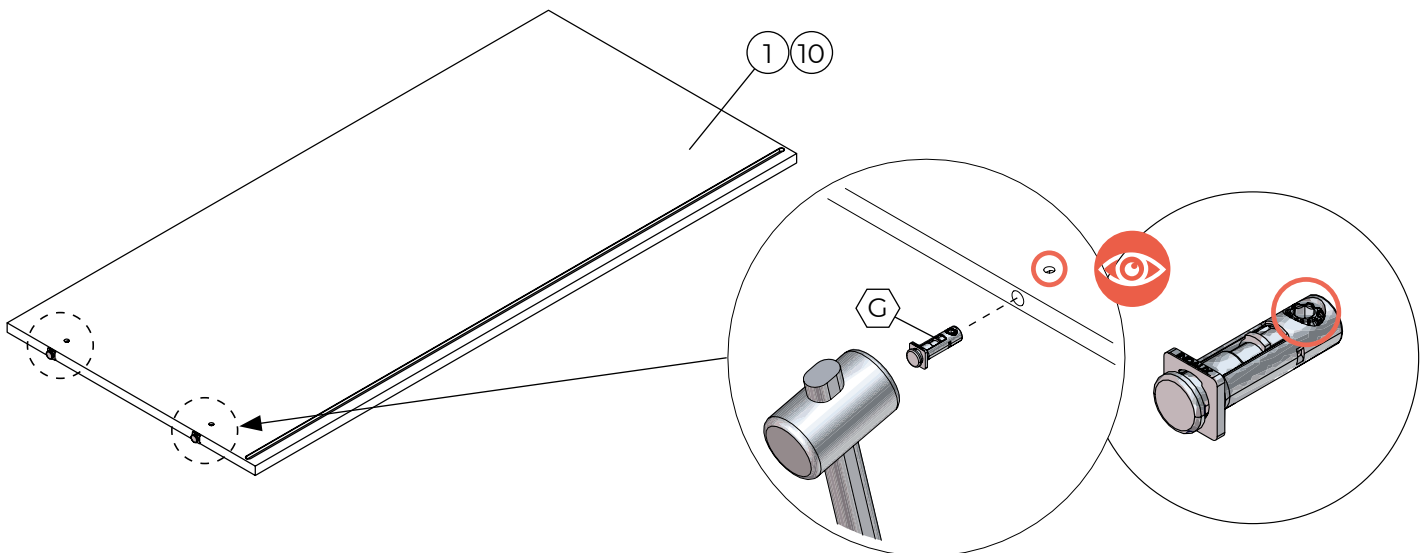

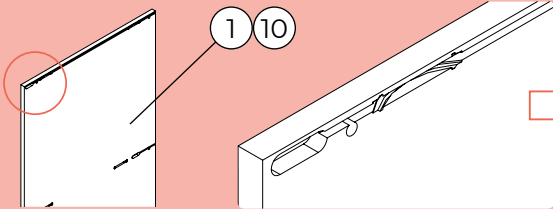

1 10



Chapitre 3 : Intérieurs /  
Chapter 3: Interiors

p.30

p.46

## 5 Montage des structures de colonne / Unit assembly

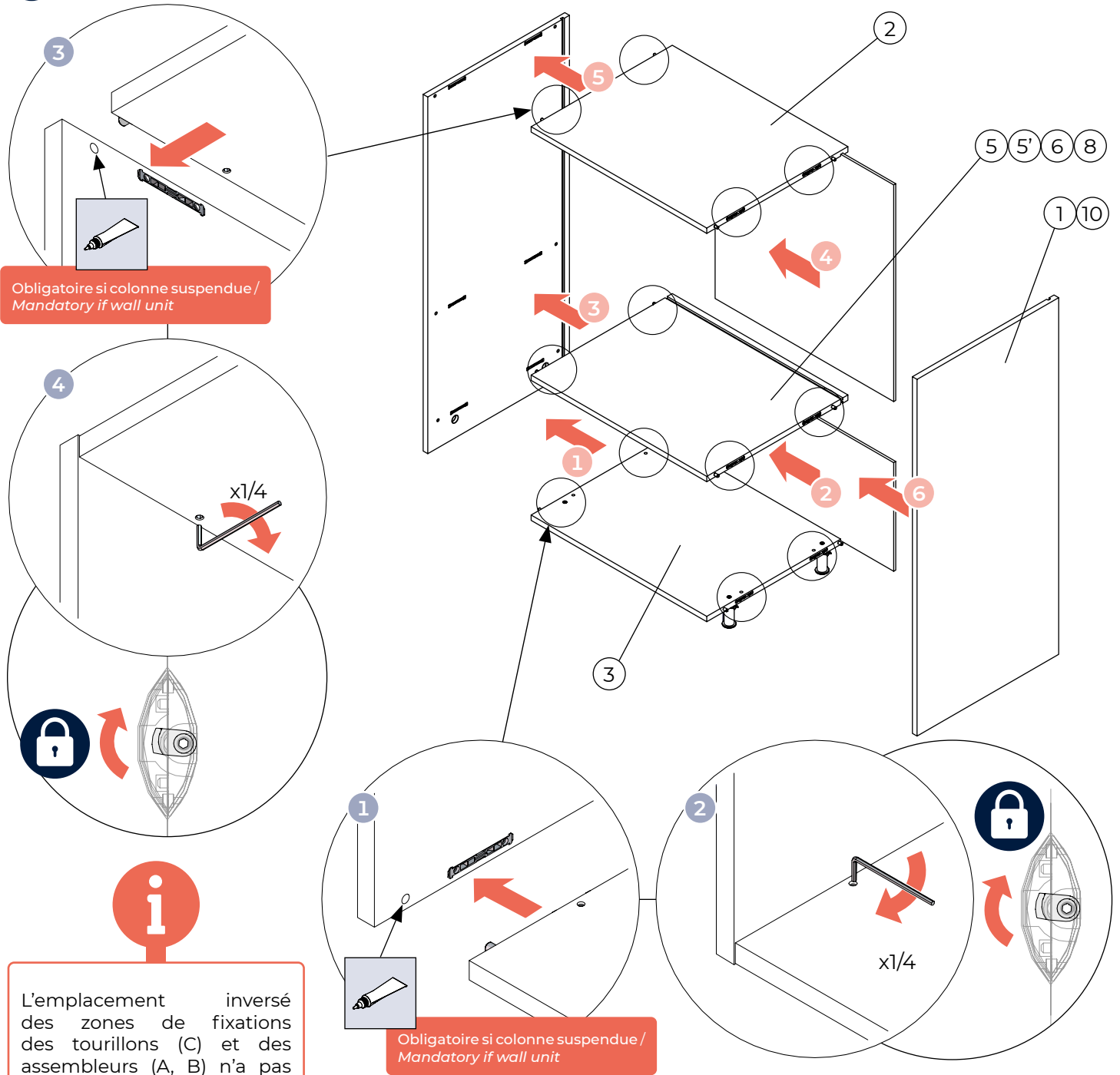

**i**

L'emplacement inversé des zones de fixations des tourillons (C) et des assembleurs (A, B) n'a pas d'incidence sur le montage du produit / The reverse location of the fixing areas of the trunnions (C) and assemblers (A, B) has no impact on the assembly of the product

Vue de dessous / Bottom view



**Astuce :** utilisez du ruban adhésif et des serre-joints pour tenir les colonnes jusqu'au maintien de la colle sur les tourillons. / **Tip:** use tape and clamps to hold the columns until the glue holds on the dowels.

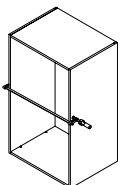

Dans le cas d'une séparation verticale au sol, il est **IMPÉRATIF** d'utiliser une fixation murale et/ou une fixation au sol afin d'éviter tout risque d'arrachement. Pour cela il est possible d'utiliser les 2 perçages bas pour tourillons. /

In the case of a vertical separation standing on the floor, you **MUST** use a wall fixation and/or a floor fixation to avoid any wrenching risk. It is possible to use the 2 bottom drillings.

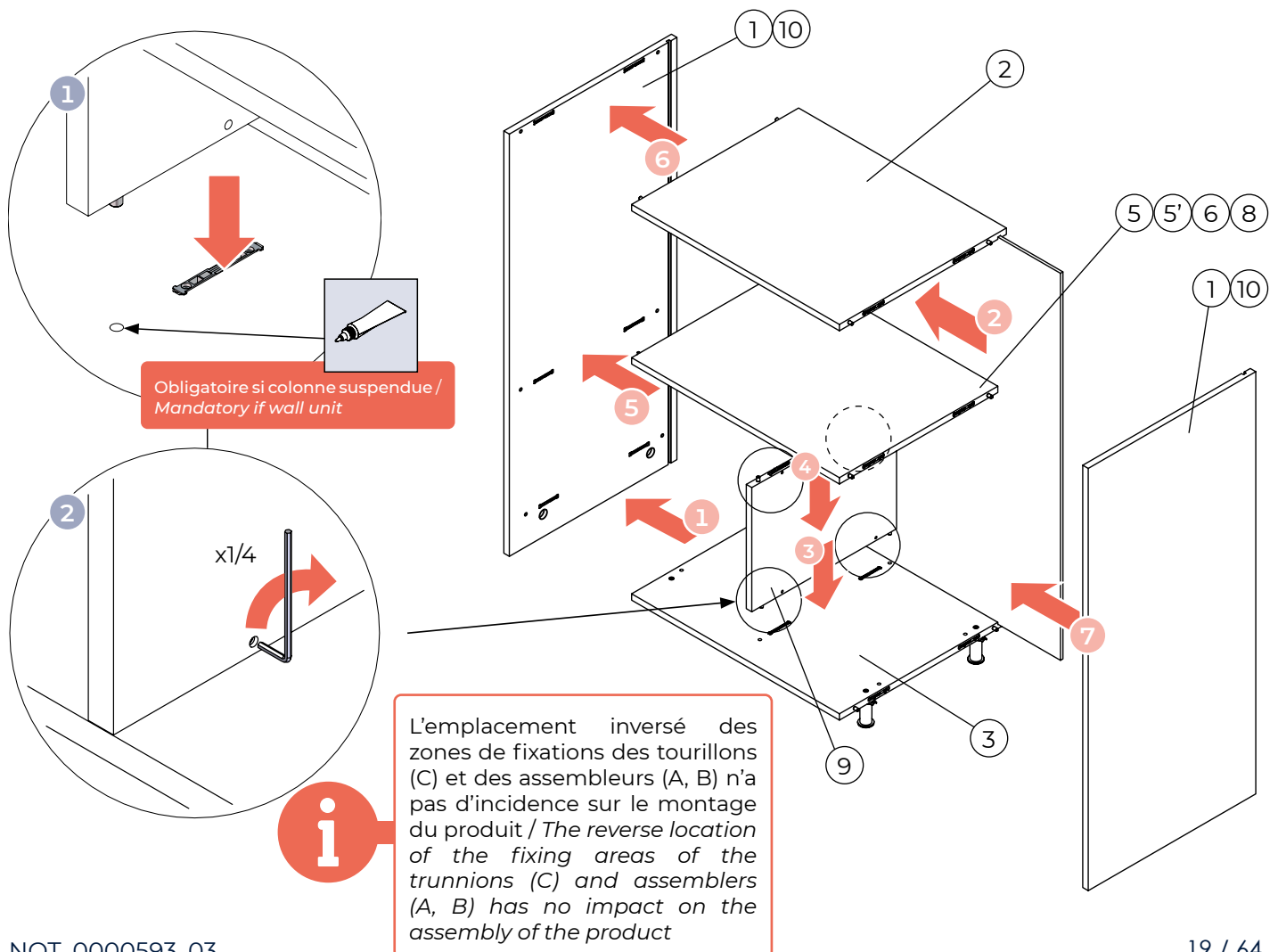
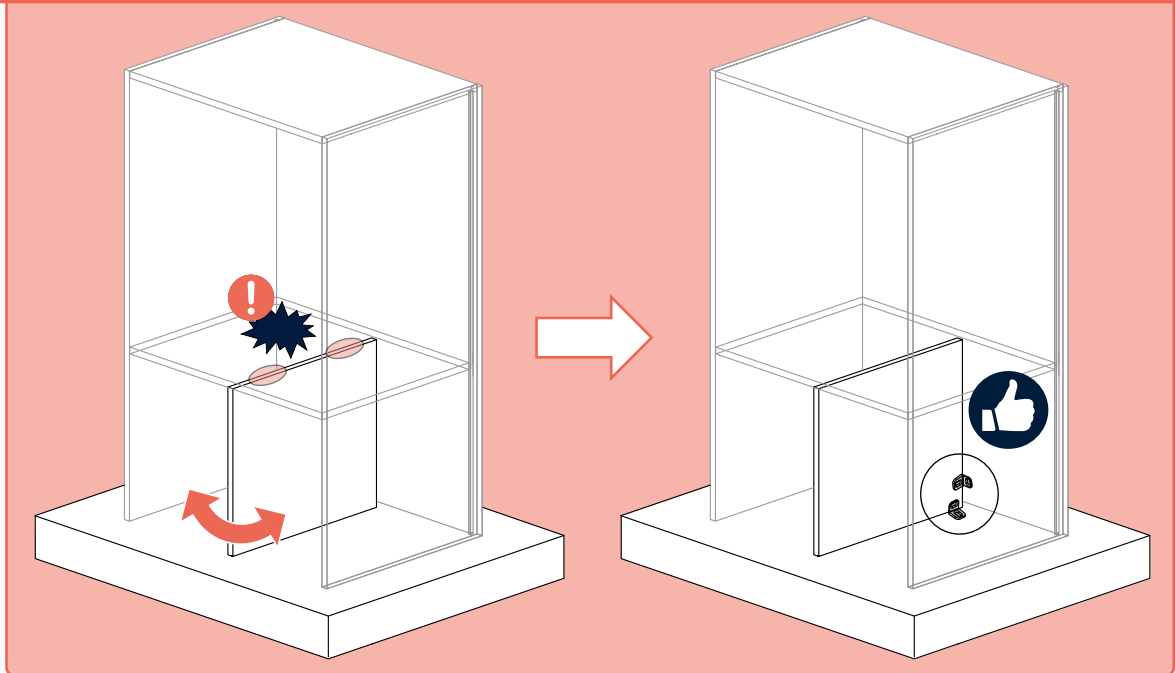

## 7 Réglages des pieds / Legs adjustments

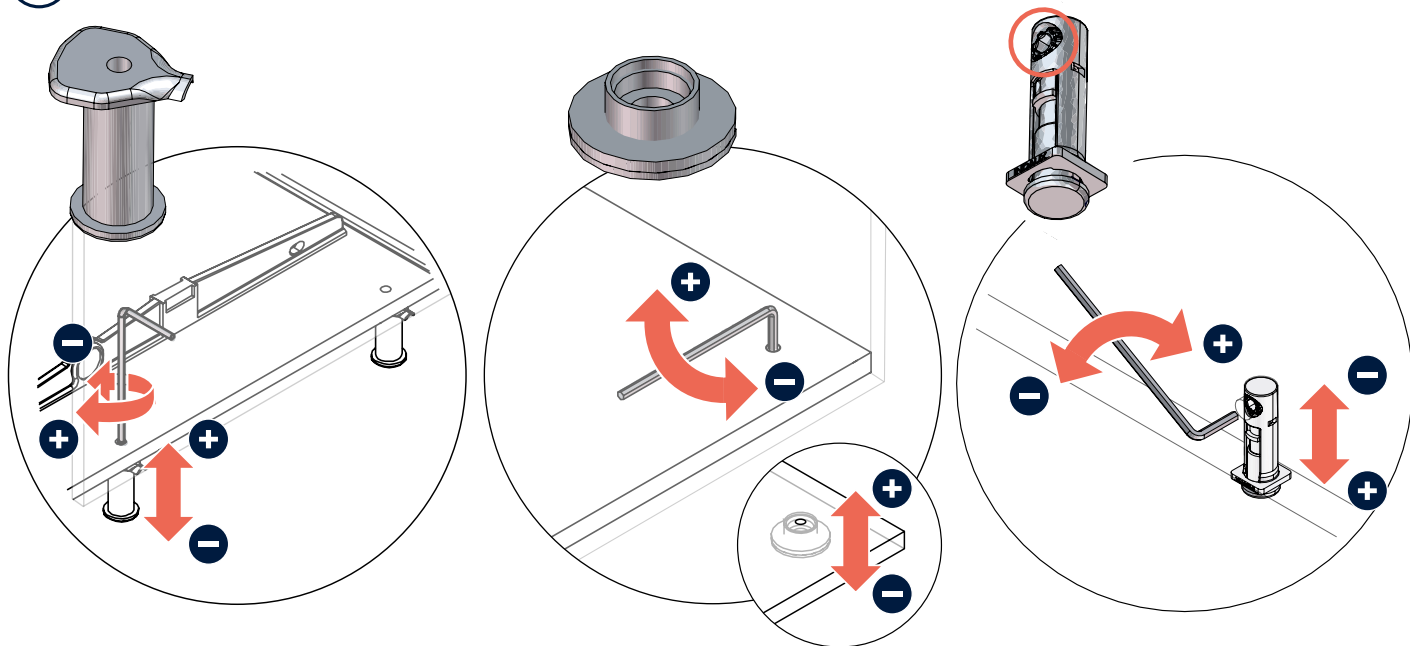

## 8

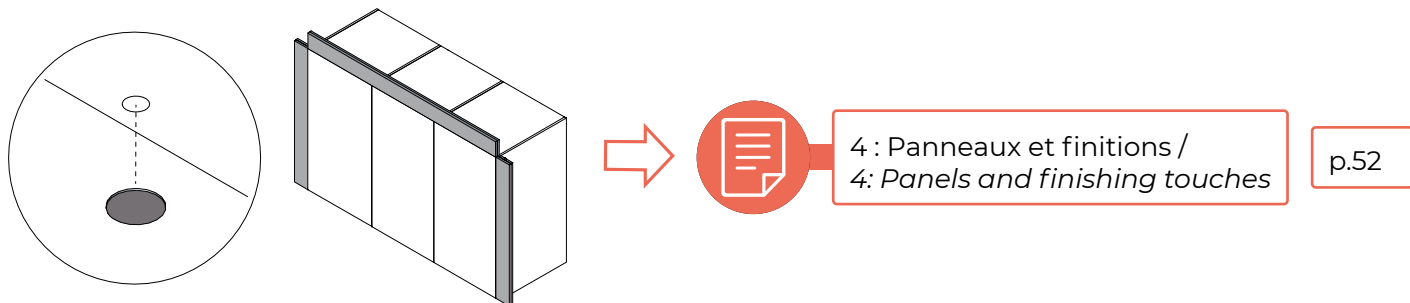

# B COLONNE D'ANGLE / CORNER UNIT

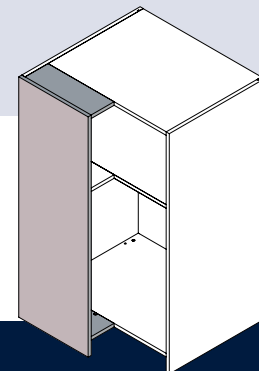

## GLOSSAIRE COLONNE D'ANGLE / CORNER UNIT GLOSSARY

1	Retour d'angle / <i>Corner return panel</i>	3	Plafond de retour d'angle / <i>Corner return angle</i>
2	Fond de retour d'angle / <i>Corner return bottom</i>	4	Etagère de retour d'angle / <i>Corner return shelf</i>

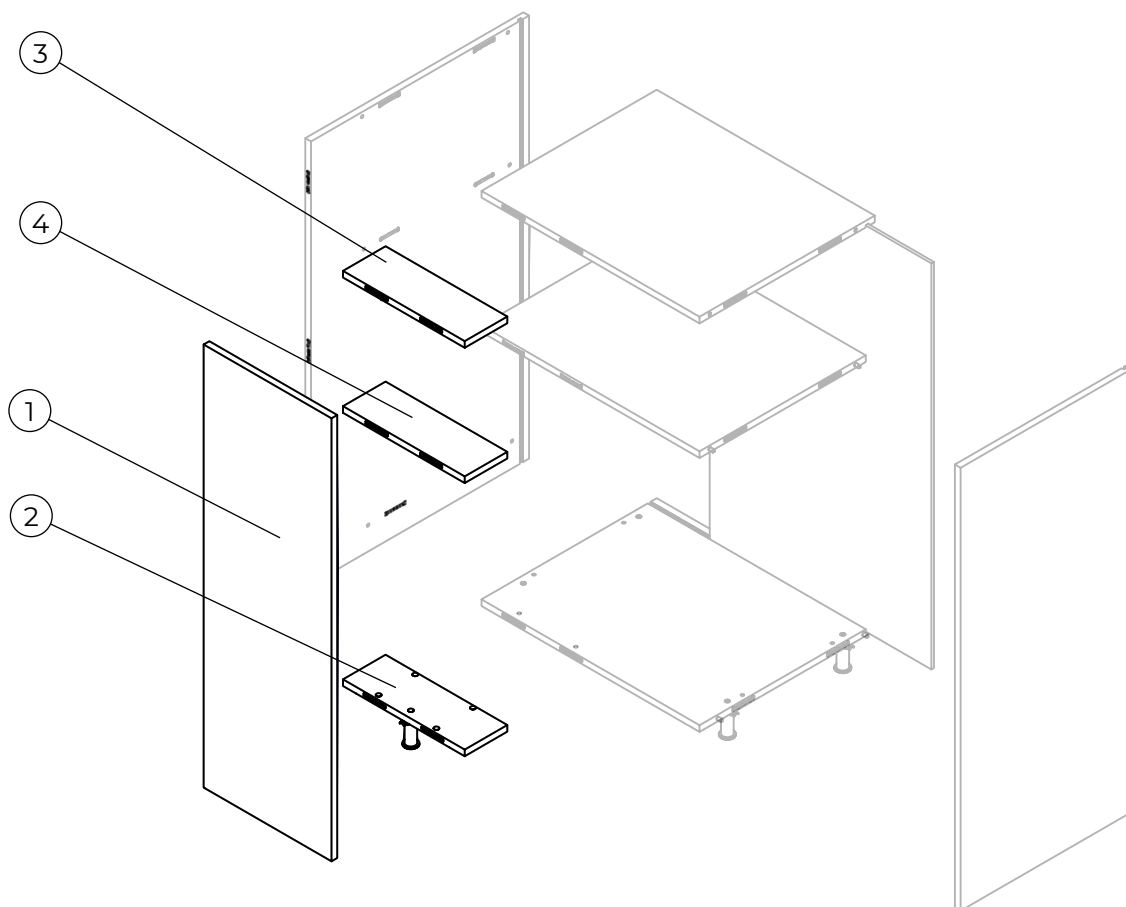

### 1 Montage de la colonne de base / *Base unit assembly*

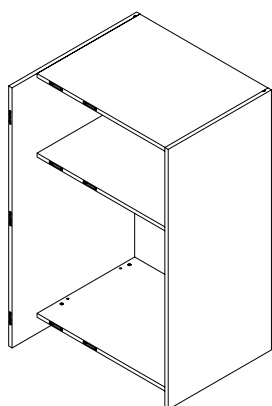

### A MONTAGE DE COLONNE / *UNIT ASSEMBLY* 1 p.13

**2** Si besoin : préparation des pieds / *If needed: legs preparation*

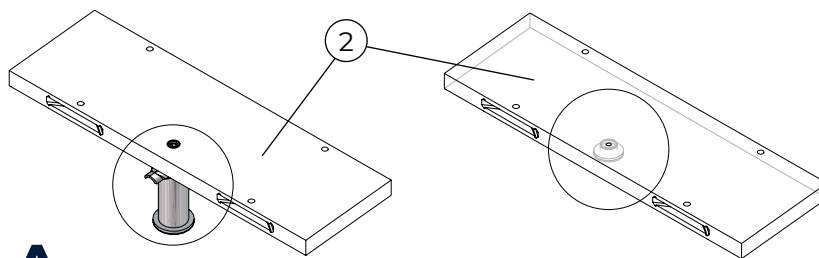

➔ **A** MONTAGE DE COLONNE / *UNIT ASSEMBLY* **4** p.16

**3** Préparation du fond, plafond et/ou étagère retour d'angle / *Bottom, top and/or shelf preparation of corner return*

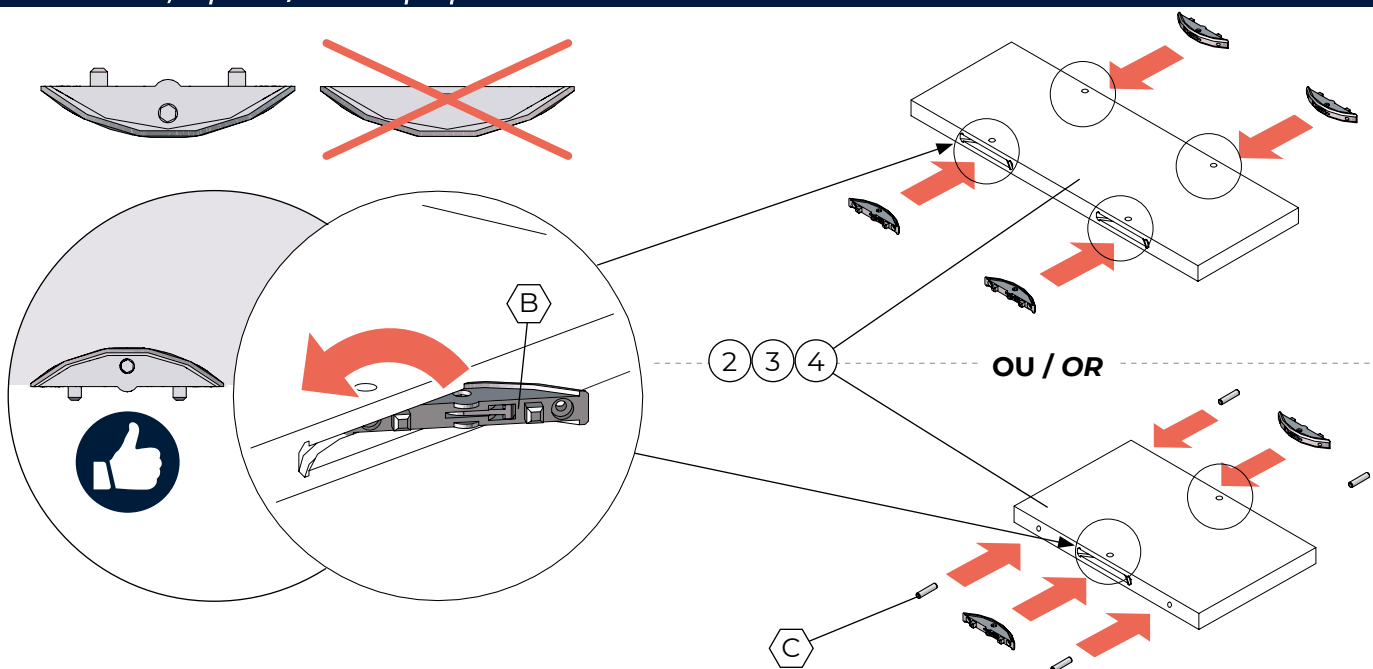

**4** Retour d'angle / *Corner*

**1**

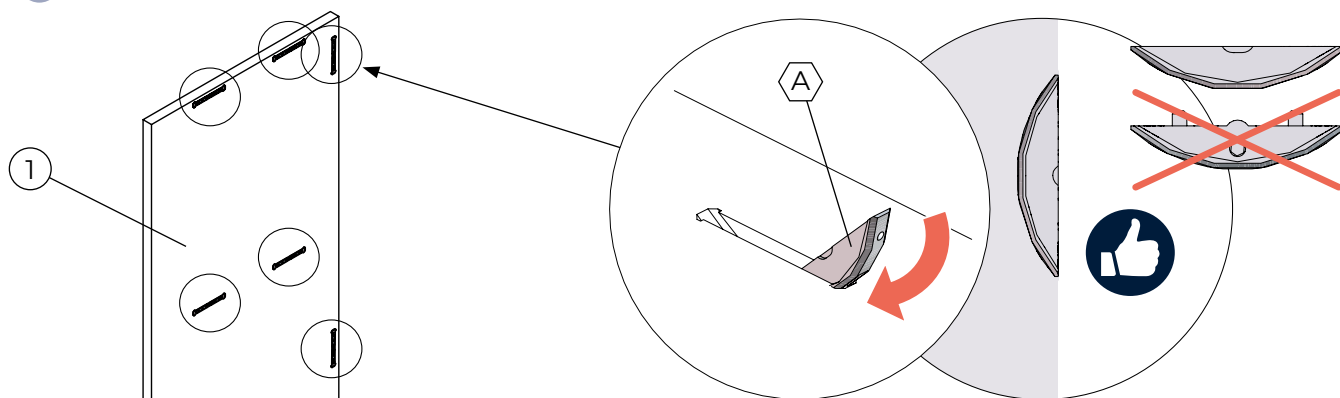

*Si étagère amovible / If adjustable shelf*

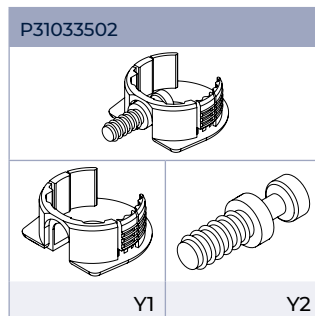
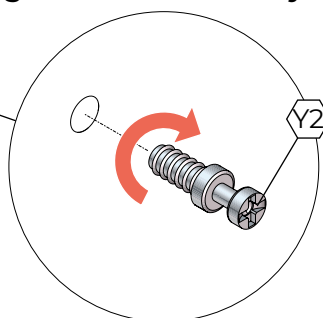

2

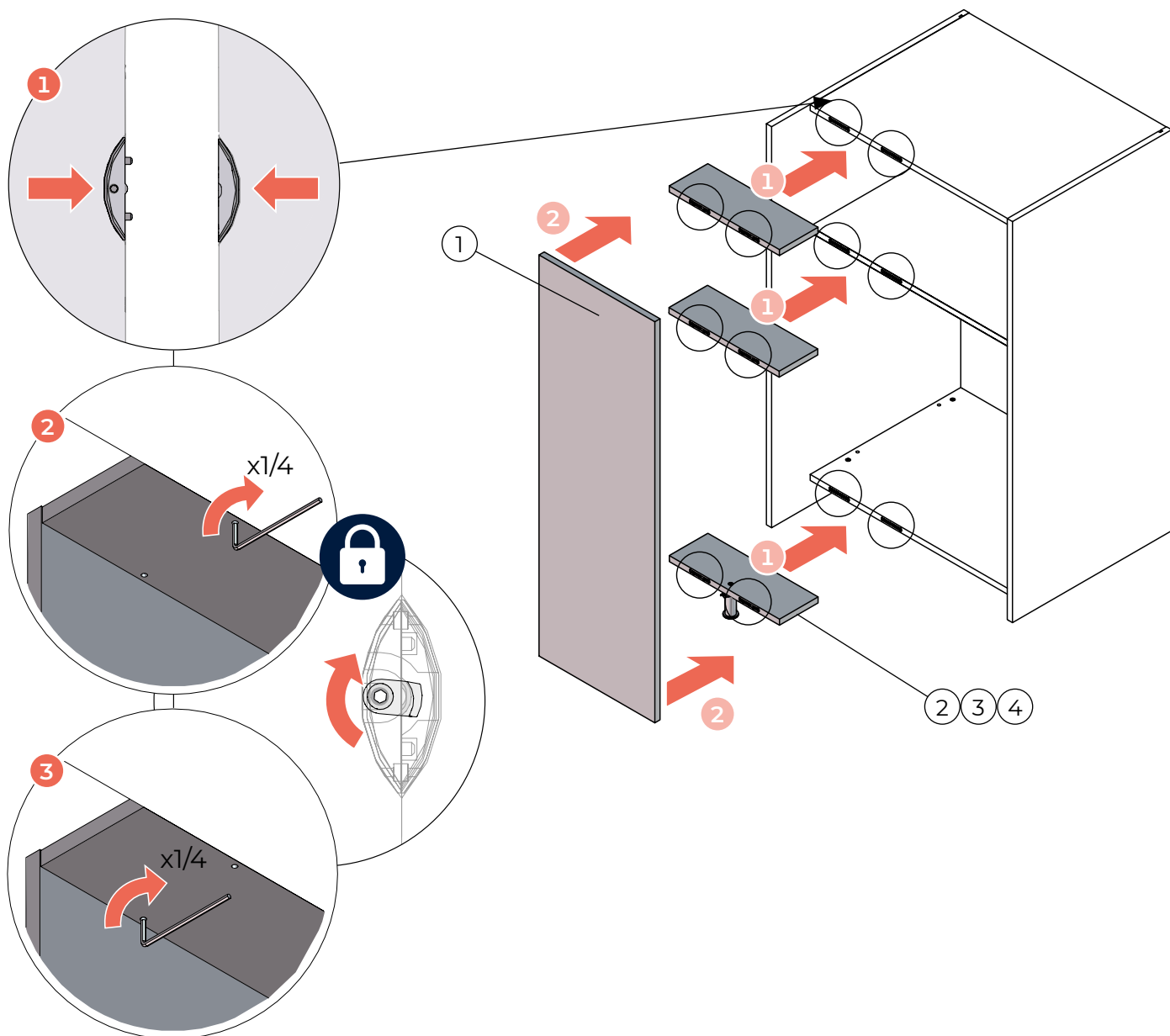

3

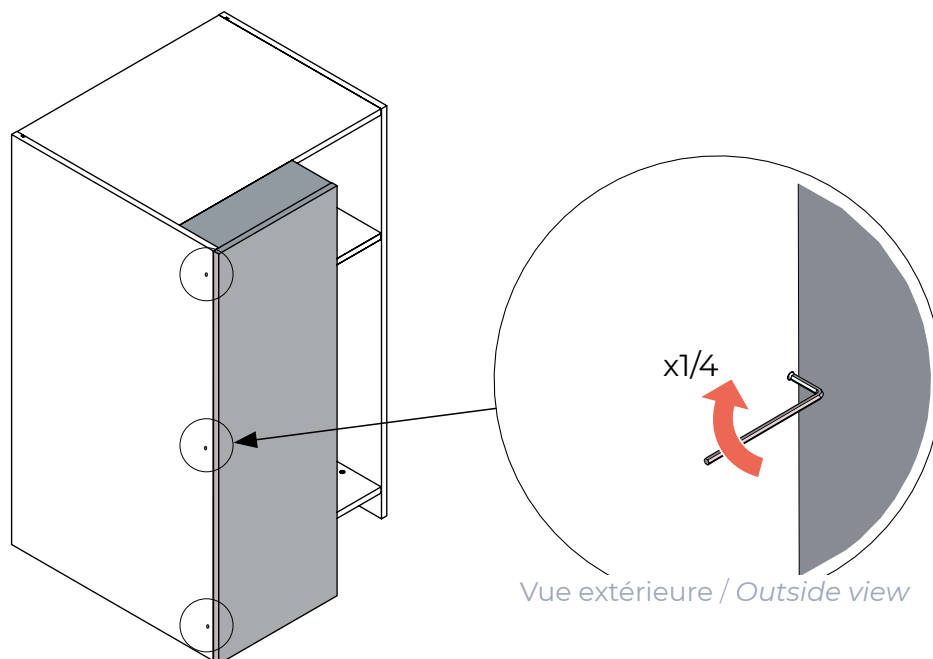

**i** Si étagère amovible : / If adjustable shelf:

**1**

P1080211	P31031901
Z1	Z2

**2**

**3**

CTATK
Z2

**5**

➔ 4 : Panneaux et finitions / 4: Panels and finishing touches p.52

# C COLONNE SUSPENDUE / WALL UNIT

RAPPEL QUINCAILLERIE SPECIFIQUE / SPECIFIC HARDWARE REMINDER

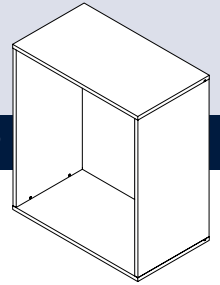

Si colonne suspendue : / If hanging unit:				
P31010725	P31010726	RAILSUS	P29452900	P31000368
L	M	N	Ø4x16 O	P

## 1 Montage de la colonne / Unit assembly



Suivre le montage classique en veillant à coller les tourillons **C** à chaque étape /  
Follow regular assembly making sure to use glue on every **C** trunnion



### A MONTAGE DE COLONNE / UNIT ASSEMBLY 1 p.13

P29449600	P31000368
C	P

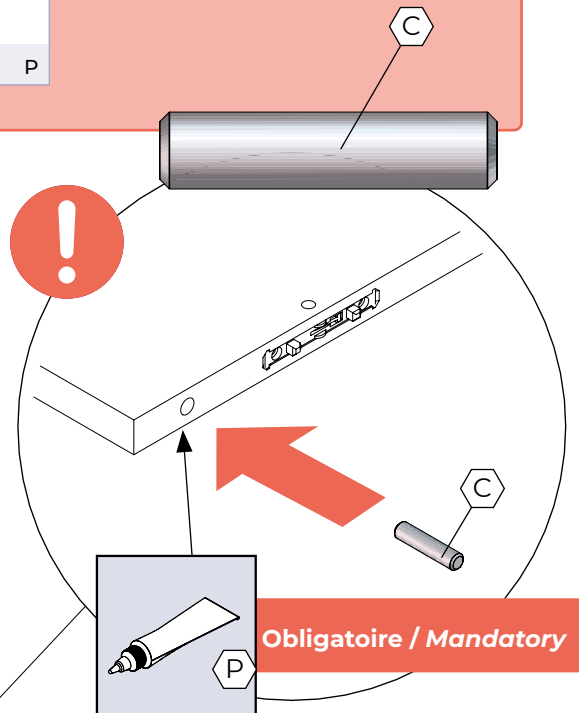
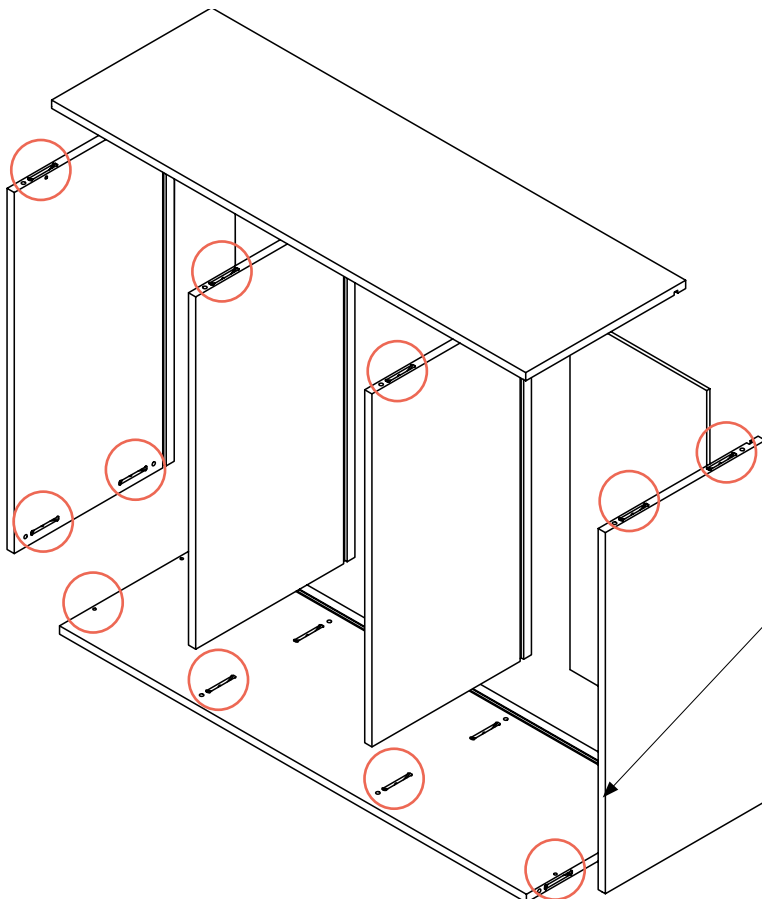

L'emplacement inversé des zones de fixations des tourillons (C) et des assembleurs n'a pas d'incidence sur le montage du produit / The reverse location of the fixing areas of the trunnions and assemblers has no impact on the assembly of the product

## 2 Perçage du dos / Back drilling



NOT\_0000090  
 Gabarit de perçage - Dos pour suspentes invisibles /  
 Drilling guide - Back panels for invisible suspending bar

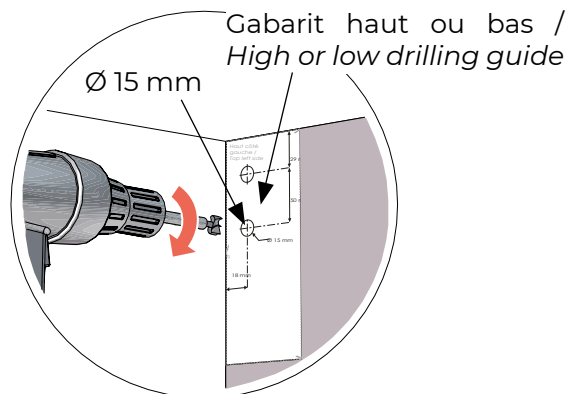
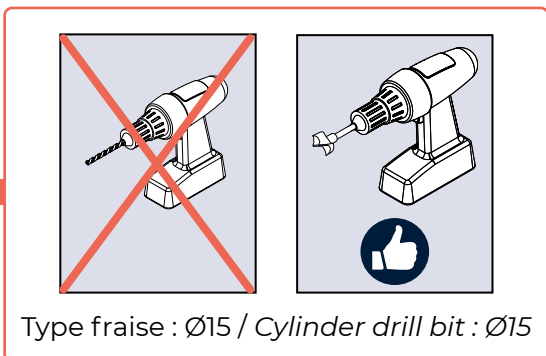

Gabarit **gauche**  
**position haute** /  
**Upper left** drilling  
 guide

Gabarit **droit**  
**position haute** /  
**Upper right**  
 drilling guide

Gabarit **gauche**  
**position basse** /  
**Lower left** drilling  
 guide

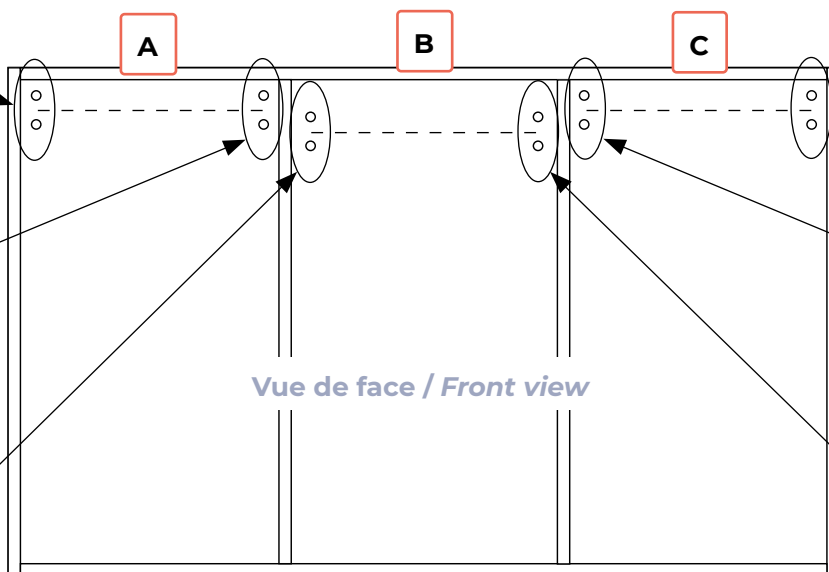

Gabarit **droit**  
**position haute** /  
**Upper right**  
 drilling guide

Gabarit **gauche**  
**position haute** /  
**Upper left** drilling  
 guide

Gabarit **droit**  
**position basse** /  
**Lower right**  
 drilling guide

## 3 Montage des suspensions / Hanging brackets assembly

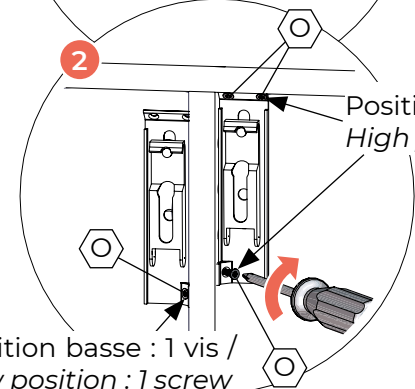
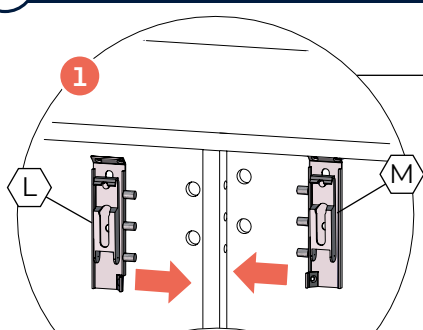

Position basse : 1 vis /  
 Low position : 1 screw

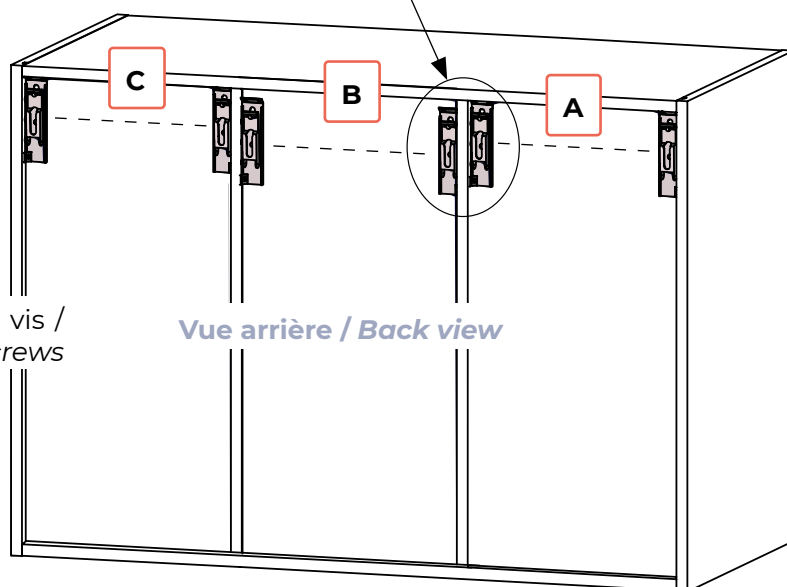

## ATTENTION / CAUTION

4 vis minimum réparties sur la longueur, dont 1 vis obligatoire à chaque extrémité

4 screws minimum distributed over the length, including 1 screw required at each end

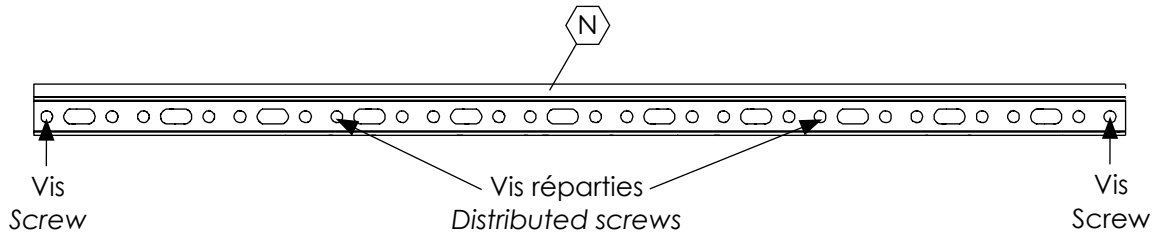

Une étiquette est collée sur chaque rail :

- **Dim7** donne la position en largeur du rail par rapport à l'extérieur gauche du meuble  
- **Dim6** donne la position en hauteur du dessous du rail au dessus du meuble. /

A label is fixed on each rail:

- **Dim7** gives the horizontal position of the rail in relation to the left exterior of the unit

- **Dim6** gives the vertical position of the underside of the rail above the unit.

Dés: <b>RAIL PR SUSPENSIONS INV DÉBITÉ</b>		Colonne: Pièce: <b>000</b>							
Dim: <b>7610 x 82 x 270</b>		N° AR: <b>399157 - 041(001)</b>							
Col:		Gamme: <b>AT28 REC SCIE FEMI</b>							
SFL: <b>50/24</b> Dest: <b>Z06 LE</b>									
 0054659561520000 A		<table border="1"> <tr> <td>6</td> <td>0083,8</td> <td>7</td> <td>0780,5</td> <td>8</td> <td>9</td> <td>10</td> </tr> </table>	6	0083,8	7	0780,5	8	9	10
6	0083,8	7	0780,5	8	9	10			

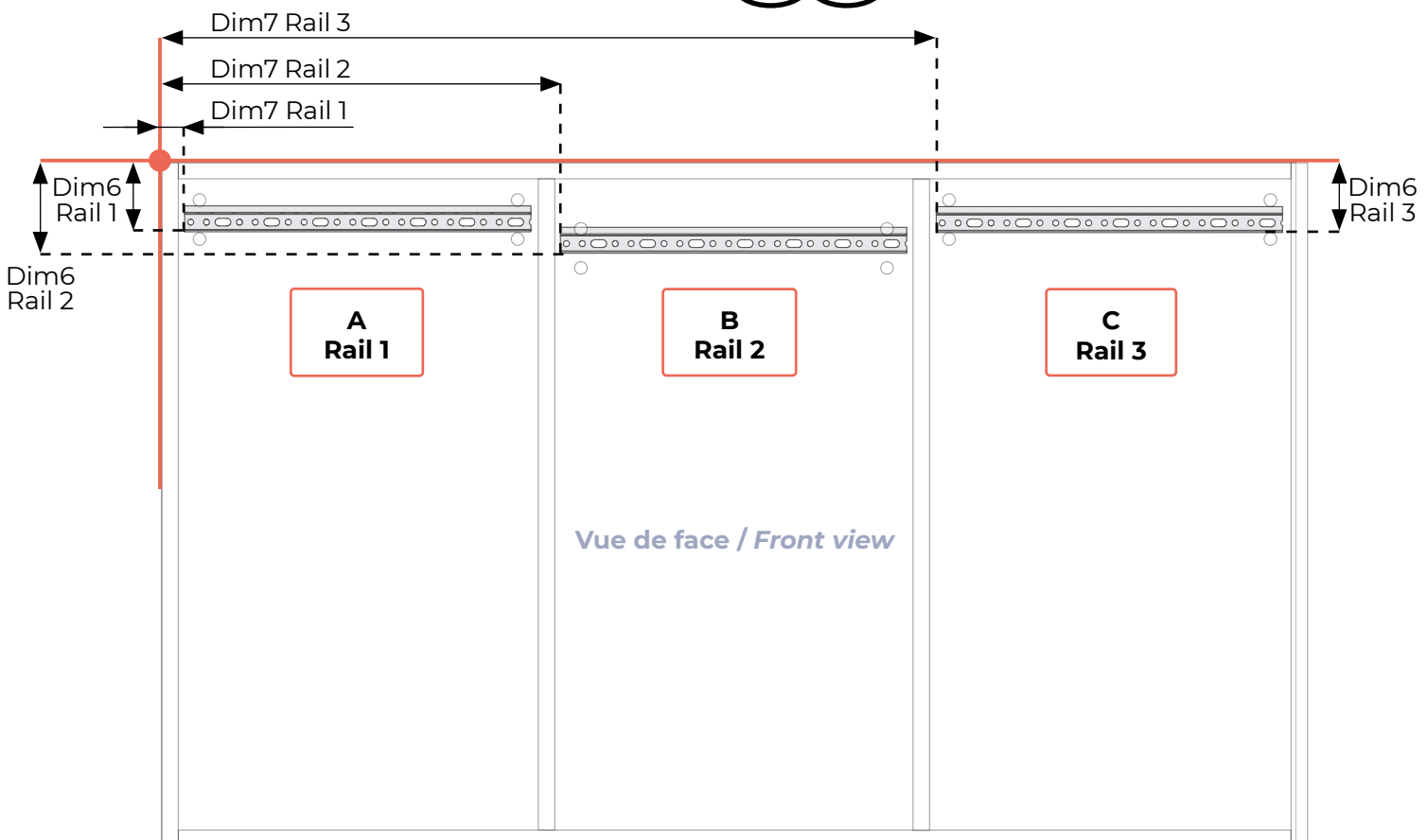

## 5 Fixation au mur / Wall fixations

### 1 Préparation des suspensions / Hanging brackets preparation

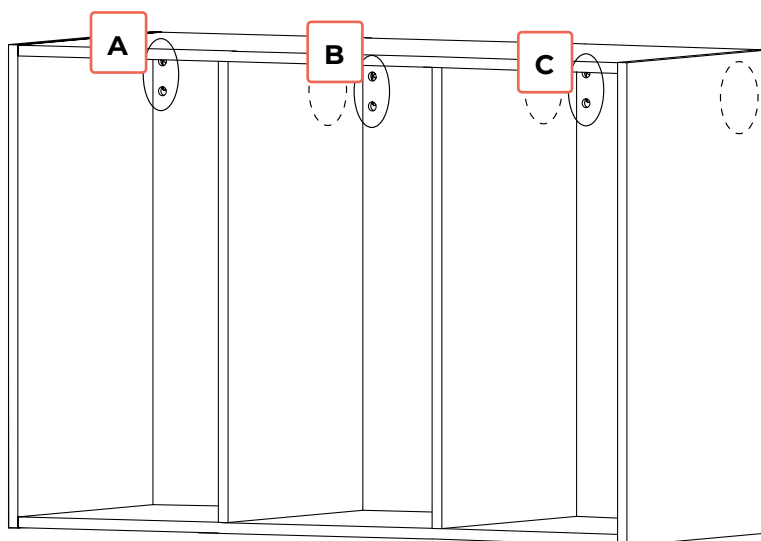
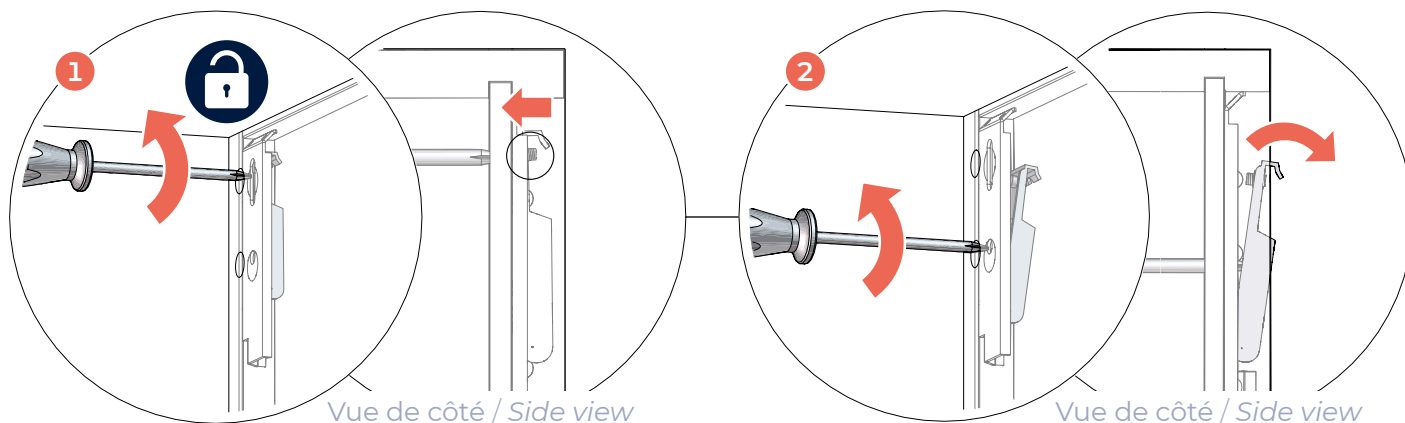

### 2 Montage au mur / Wall hanging

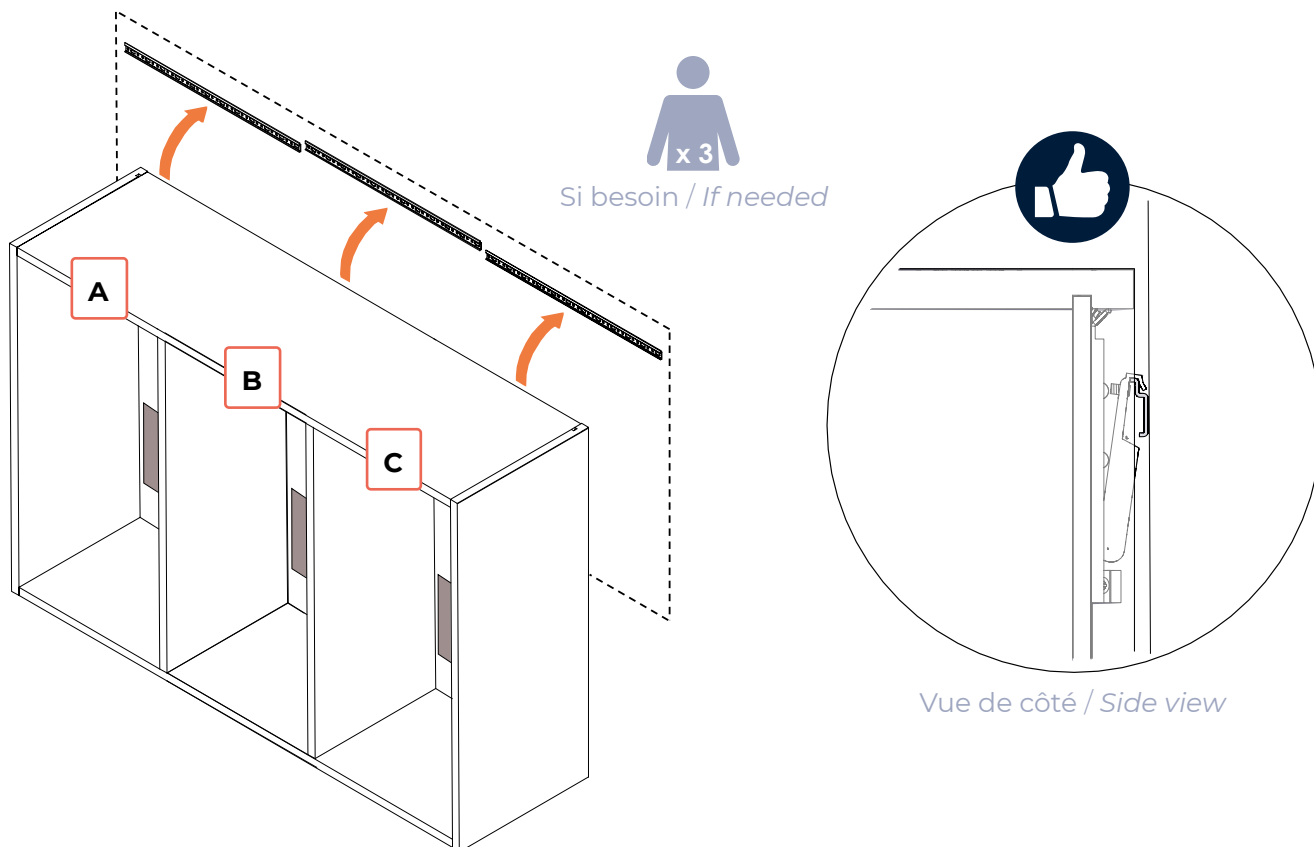

## 6 Verrouillage anti-décrochement / Take down locking block

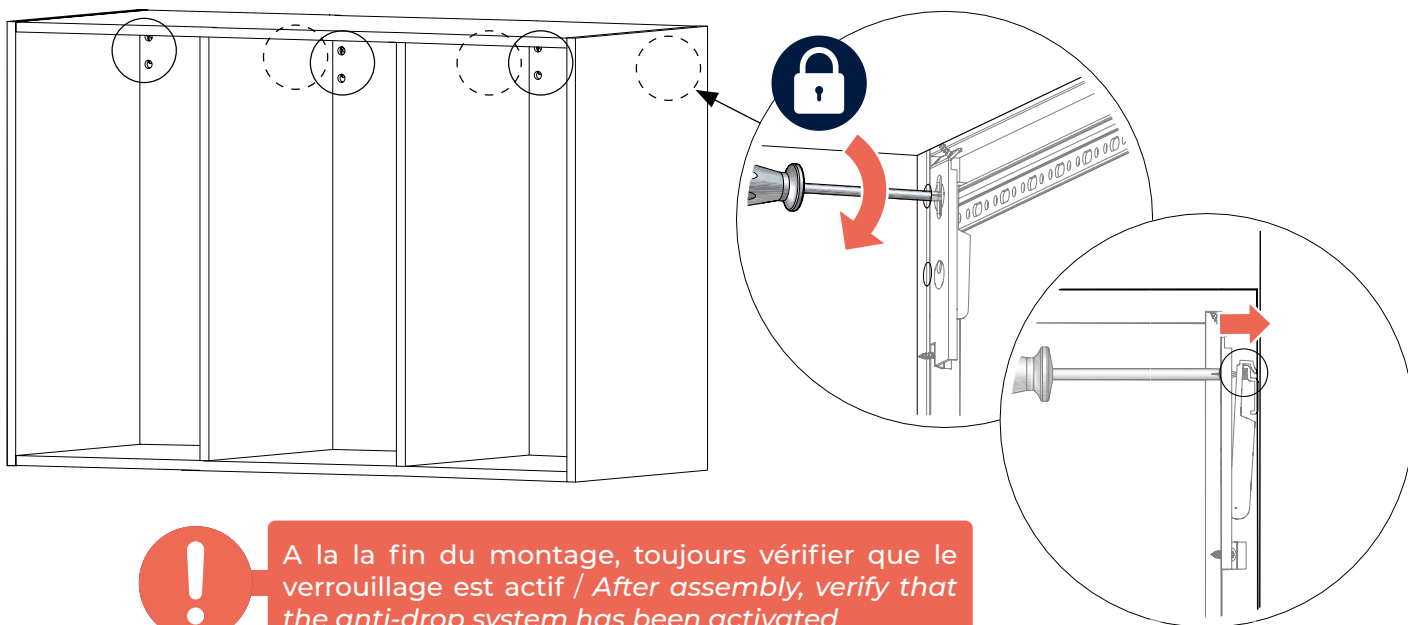

## 7 Réglages / Adjustments

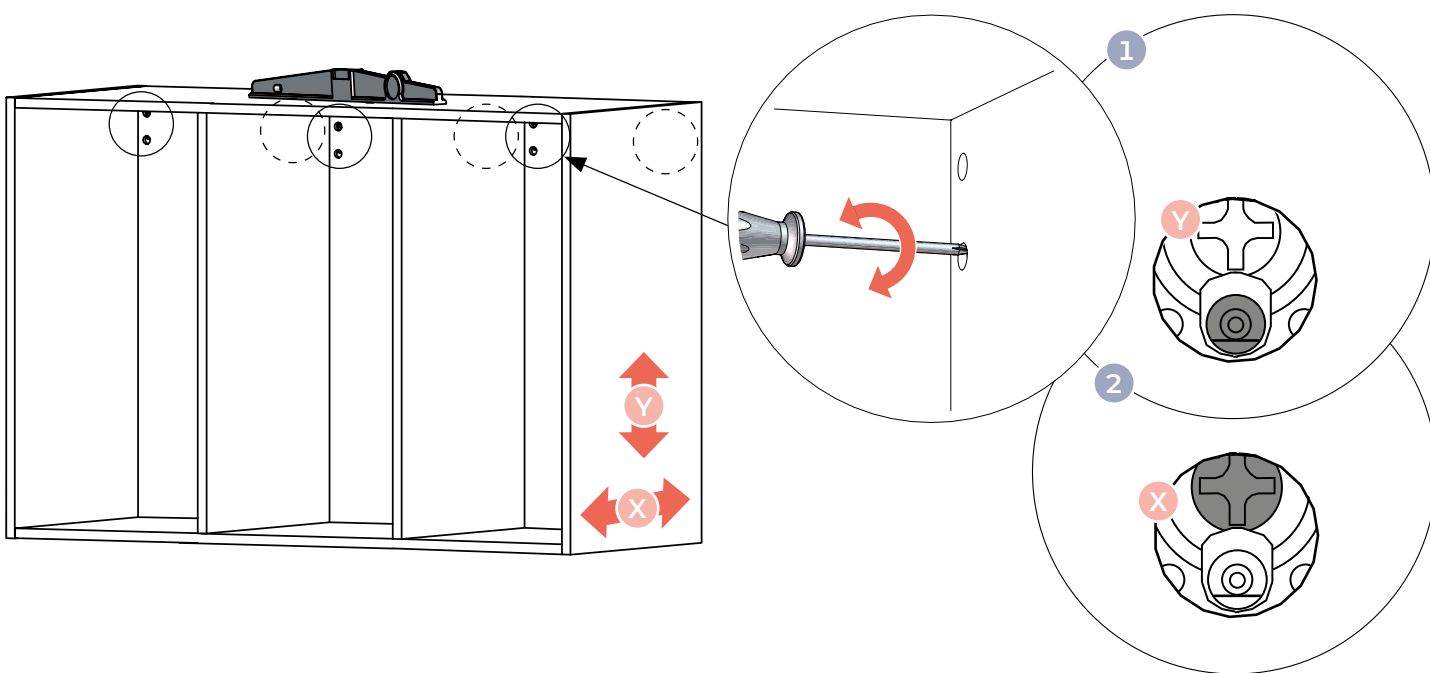

## 8

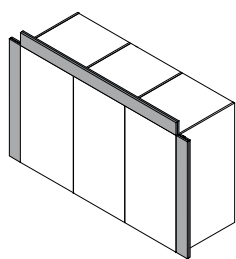
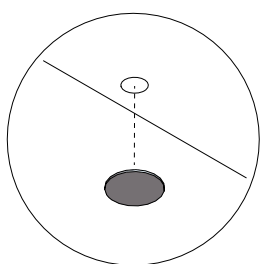











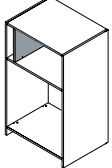

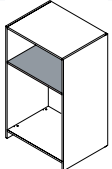

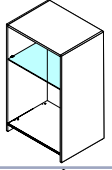

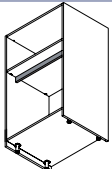
4 : Panneaux et finitions /  
4: Panels and finishing touches

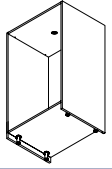
p.52

# 3

## INTÉRIEURS INTERIORS

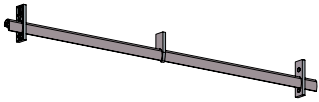
<b>A</b>	SÉPARATION VERTICALE / <i>VERTICAL SPACER</i>	 		31
<b>B</b>	ÉTAGÈRE AMOVIBLE / <i>ADJUSTABLE SHELF</i>	 		32
<b>C</b>	ÉTAGÈRE VERRE / <i>GLASS SHELF</i>	 		33
<b>D</b>	BANDEAU DE RENFORT / <i>SHELF REINFORCER</i>	 		34
<b>E</b>	SPOT LED / <i>LED SPOTS</i>	 		35
<b>F</b>	PROFIL LED À ENCASTRER / <i>SLOT-IN LED PROFILES</i>	 		38
<b>G</b>	PENDERIE (AVEC OU SANS LED) / <i>WARDROBE BAR (WITH OR WITHOUT LED PROFILES)</i>	 		44

OUTILLAGE NON FOURNI / *NOT SUPPLIED*

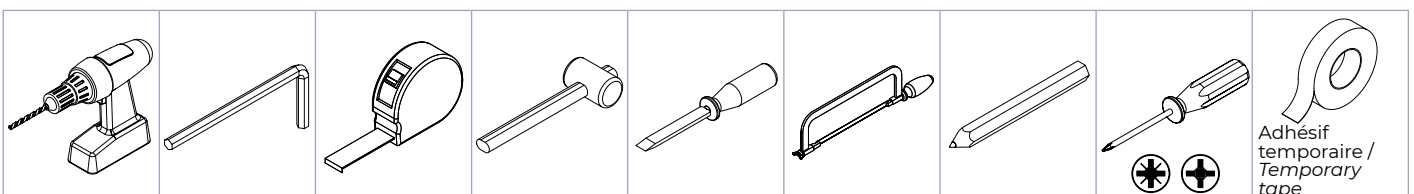

# A SÉPARATION VERTICALE / VERTICAL SPACER

QUINCAILLERIE / HARDWARE

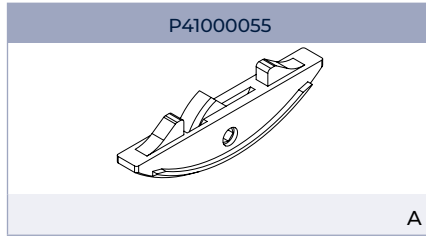
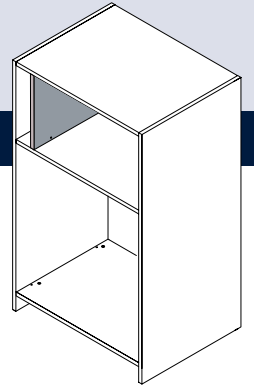

1

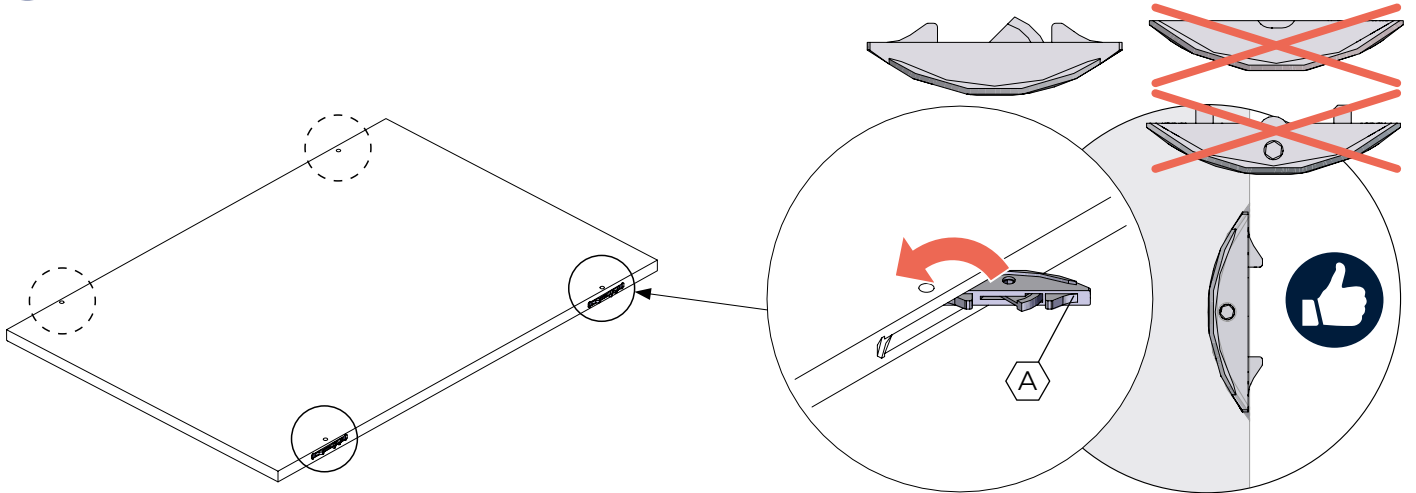

2

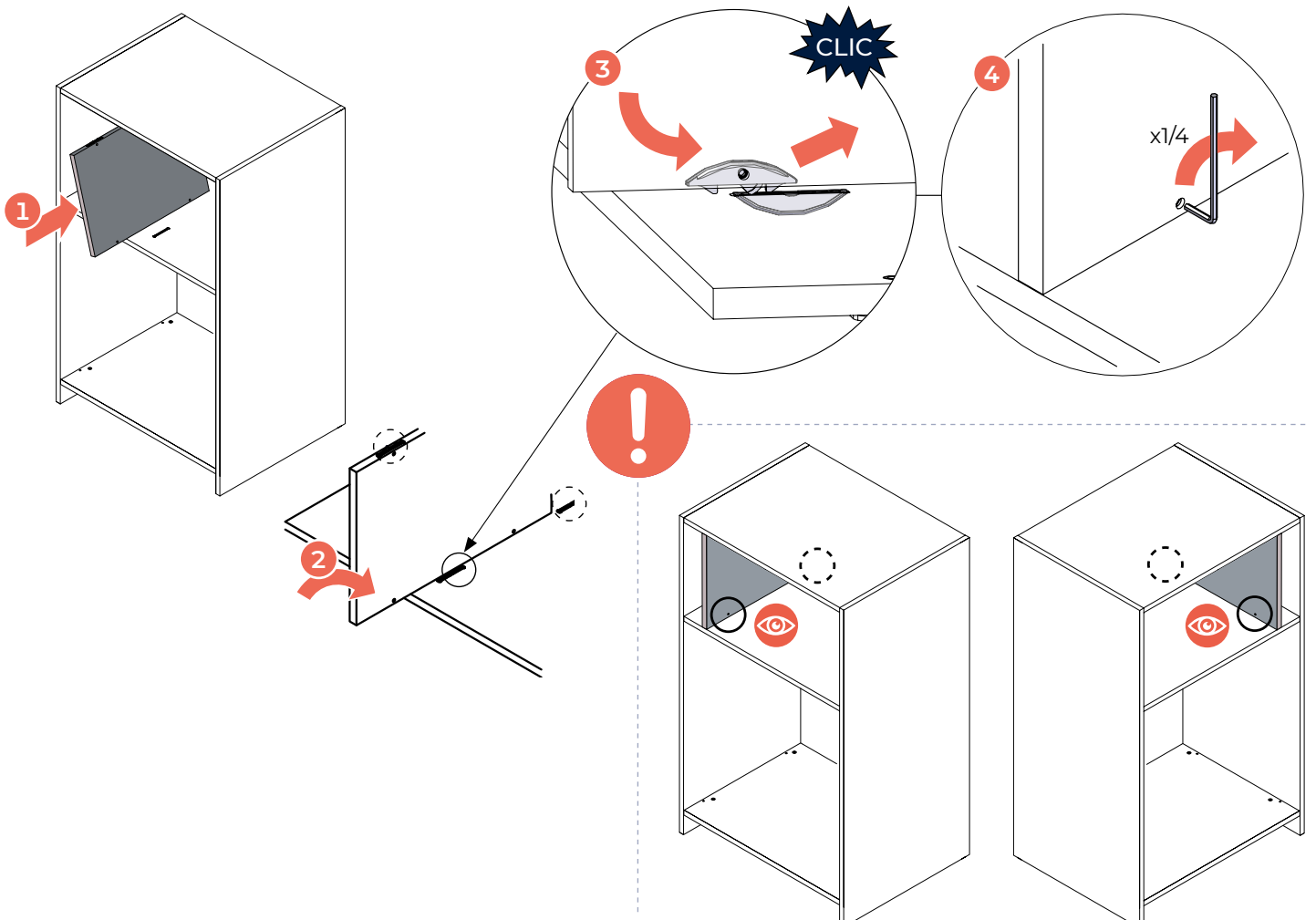

# B ÉTAGÈRE AMOVIBLE / ADJUSTABLE SHELF



QUINCAILLERIE / HARDWARE

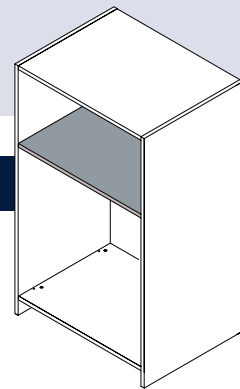

P31031901	P1080211	CTADL
x4 A	x4 B	x4 C

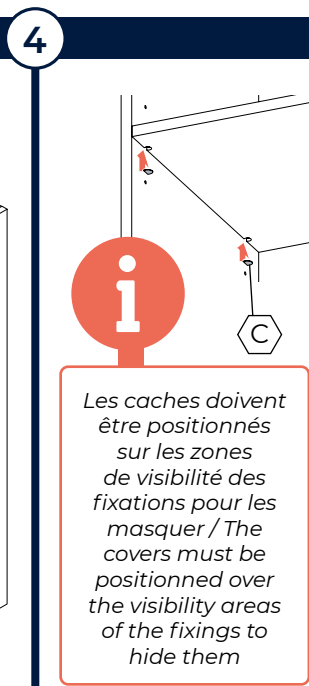
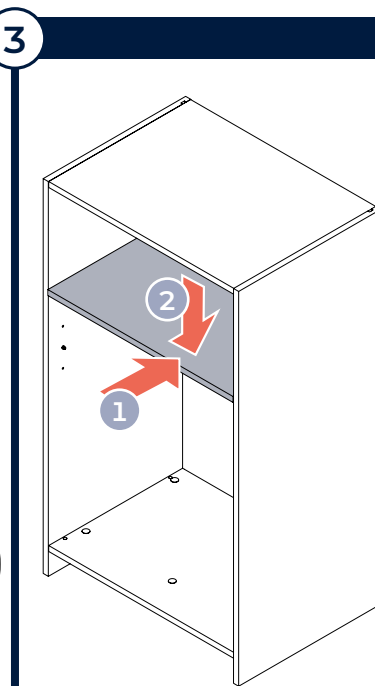
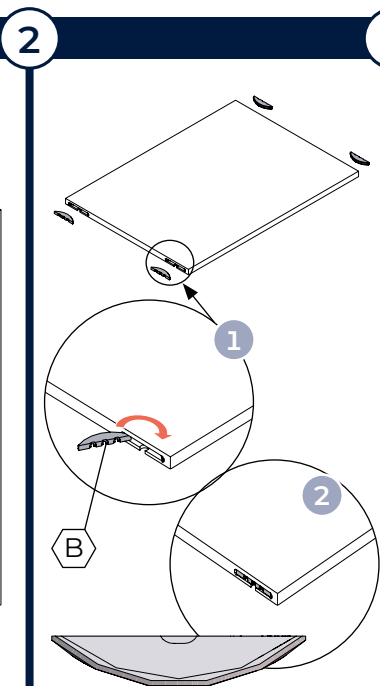
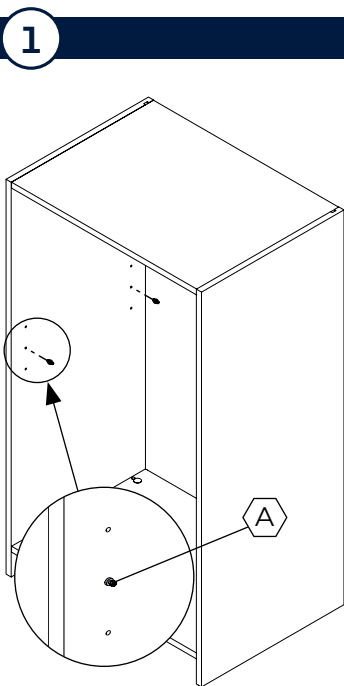

5 Si besoin / If necessary

**D** BANDEAU DE RENFORT / SHELF REINFORCER p.34

6 Si besoin : démontage / If necessary: disassembly

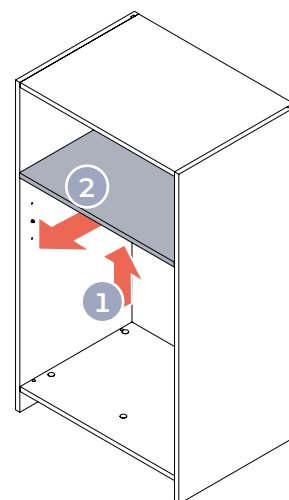
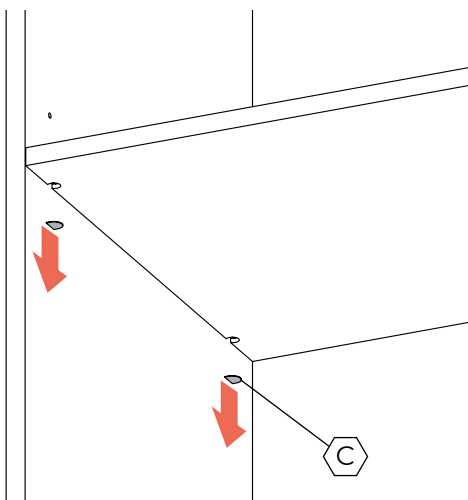

# C ÉTAGÈRE VERRE / GLASS SHELF

QUINCAILLERIE / HARDWARE

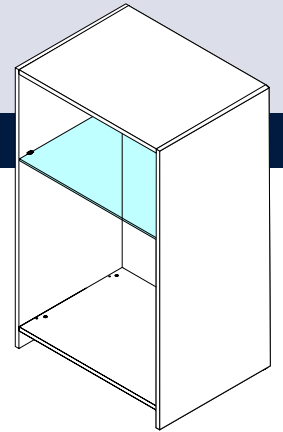
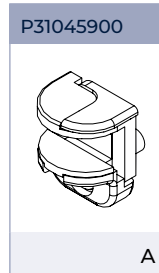

**1**

**2**

**3**

**4**

# D BANDEAU DE RENFORT / SHELF REINFORCER



QUINCAILLERIE / HARDWARE

P1080209	P1080208	P29449600
A	B	Ø8x35 C



Le bandeau de renfort peut se monter avant ou après la pose de l'étagère ou du plafond / The reinforcer band can be assembled before or after the installation of the shelf or the top

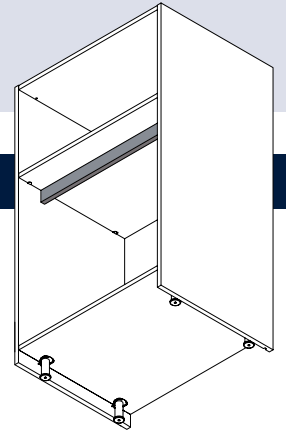

1

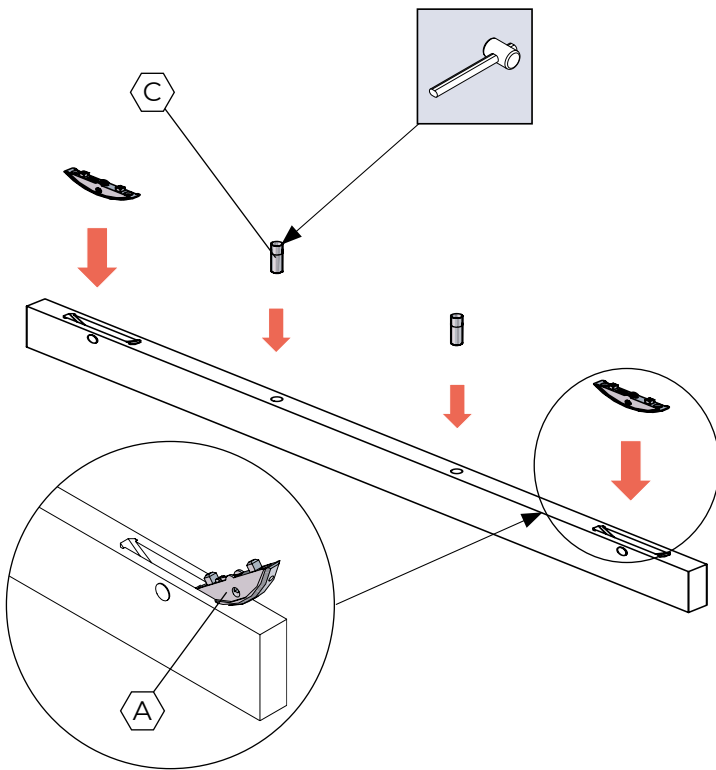

2

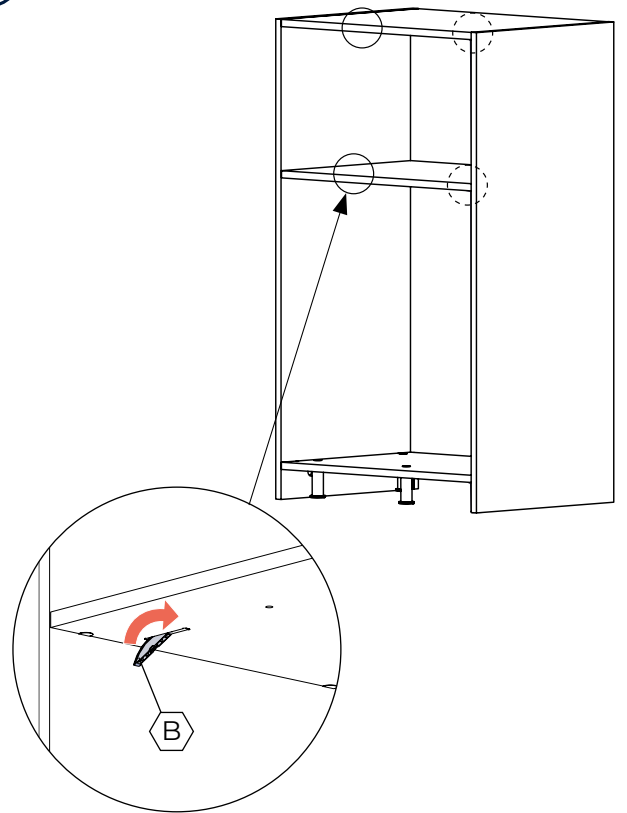

3

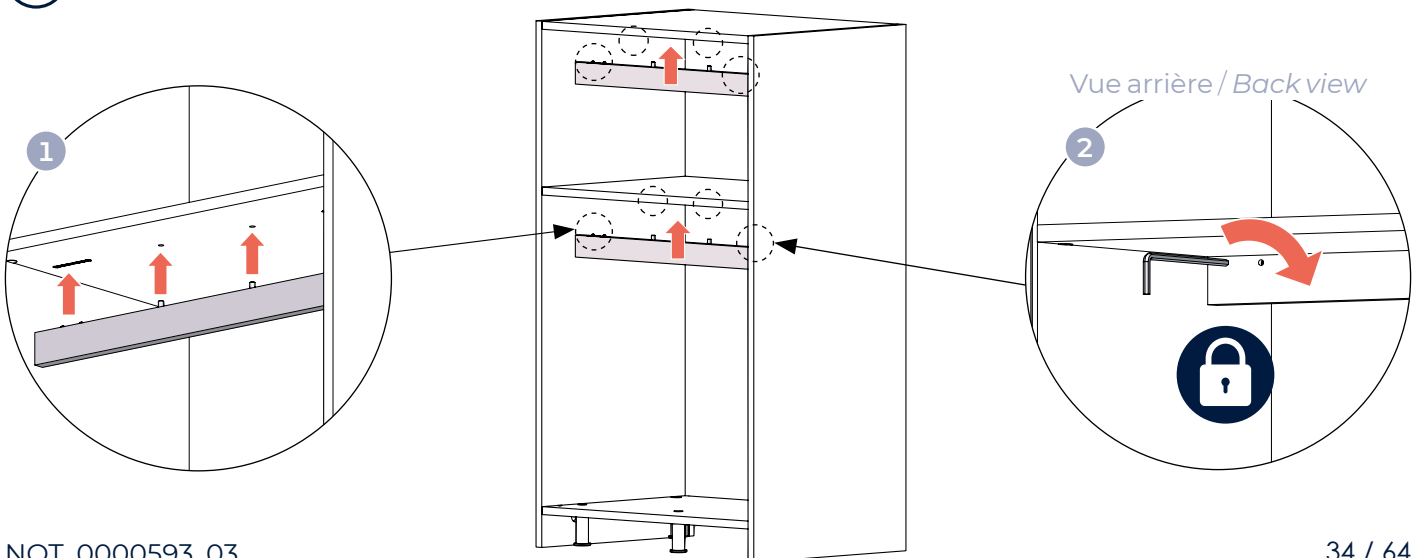

# E SPOT LED / LED SPOTS



5 min

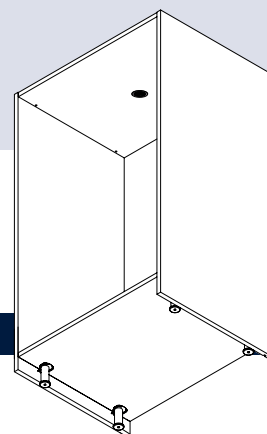

## 0 Données techniques / Technical data



Ce luminaire intègre une source lumineuse de classe F. / This light integrates a class F light source.

Références / References	SPL3000K	SPL4100K
Alimentation / Power supply	24 V ~ 50 Hz	
Puissance de la source / Light source power	2 W	
Flux lumineux de la source / Light source luminous flux	199 Lm	
Température de couleur / Colour temperature	3000°K	4000°K
Indice de protection / Index protection rating	IP20	
Isolation électrique / Electrical insulation	Classe III / Class III	

SPL3000K

SPL4100K

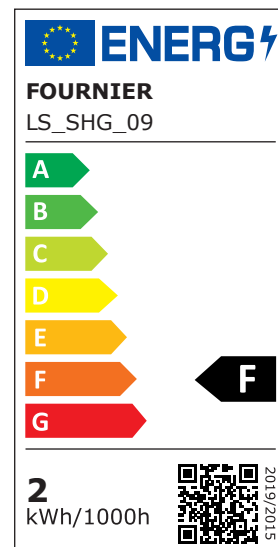
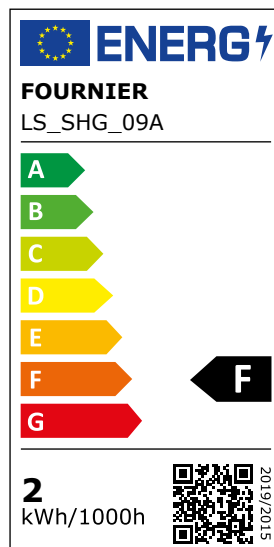

La source lumineuse de ce luminaire n'est pas remplaçable. Lorsque la source lumineuse atteint sa fin de vie, le luminaire entier doit être remplacé. / The light source of this light is not replaceable. When the light source reaches the end of its life, the entire light must be replaced.

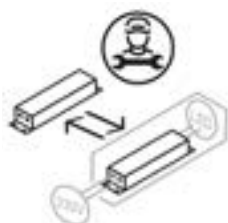

L'alimentateur de ce luminaire est remplaçable par un professionnel. / The driver of this light is replaceable by a professional.



The item should not be disposed of with household waste. Please take it to a collection point or an approved centre to ensure that it is recycled.

Points de collecte sur [www.quefairedemesdechets.fr](http://www.quefairedemesdechets.fr)  
Privilégiez la réparation ou le don de votre appareil !

## QUINCAILLERIE / HARDWARE



OU  
/ OR



+

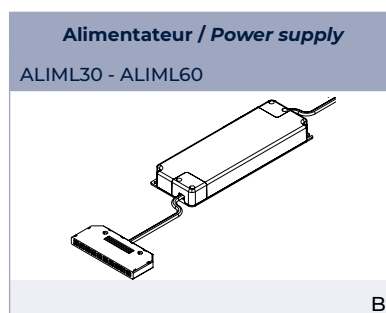

+

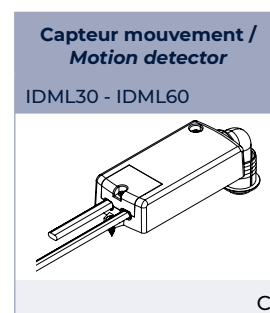

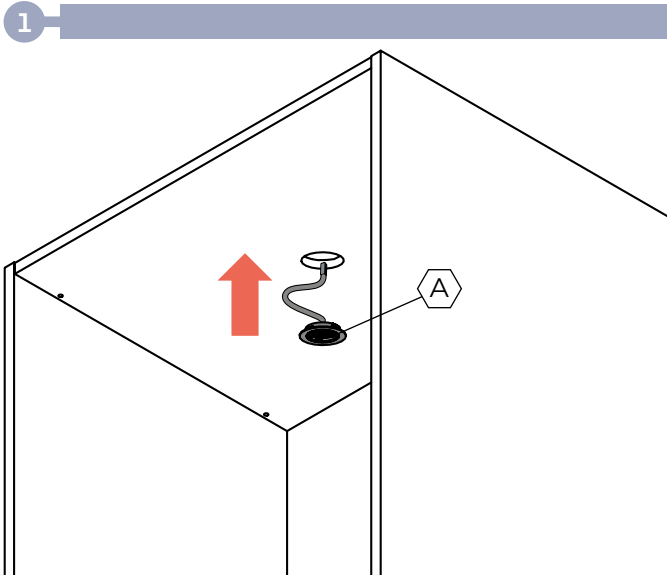
**1**

Vue de dessous / Bottom view

**2**

Haut du plafond de meuble / Top of unit

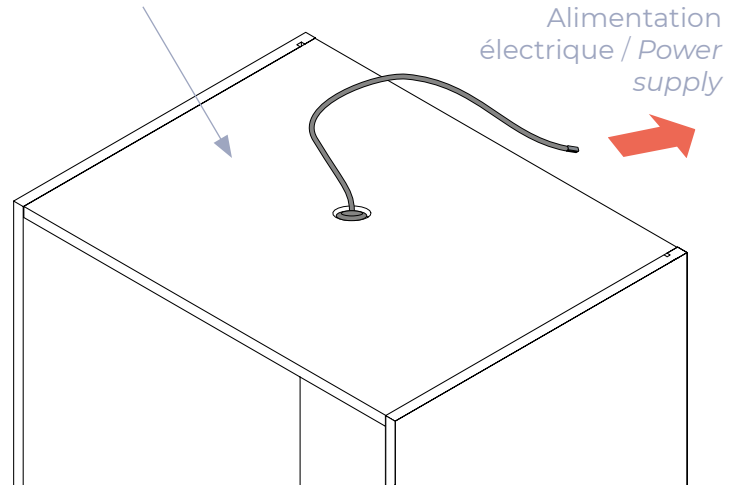
**2****Branchement électrique / Electrical connection**

Le profil doit être installé par un électricien qualifié et câblé conformément aux exigences nationales en vigueur / Profile must be installed by a qualified electrician and wired according with the requirements of the respective country

**1****Coupez l'alimentation générale / Cut off the general power supply**

Conformément à la norme NF C 15-100, raccordez l'applique à l'alimentation électrique par l'intermédiaire d'un boîtier de raccordement non fourni (classe, IPXX). / According to standard NF C 15-100, connect the light to the power supply through a connection box not supplied (IPXX, class).

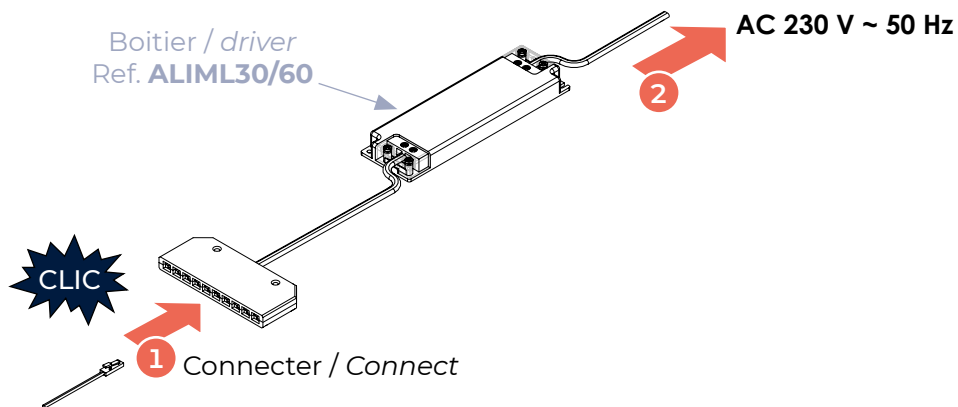
**2**

Le type et le nombre d'alimentateurs à utiliser pour votre installation dépend :

- Du nombre d'appareils à connecter
- De la puissance maximale cumulée des appareils électriques à connecter
- De l'étanchéité nécessaire /

The type and number of drivers to use for your installation depends on :

- The number of appliances to be connected
- The maximum cumulative power of the electrical appliances to be connected
- The required watertightness

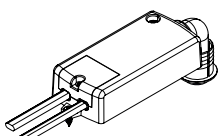
**7****Branchement d'un accessoire LED avec détecteur de mouvement / Electrical connection of a LED device with motion detection****E**

SPOT LED / LED SPOTS

**3**

p.35

### 3 Branchement d'un accessoire LED avec détecteur de mouvement / Electrical connection of a LED device with motion detector

#### 1 Coupez l'alimentation générale / Cut off the general power supply

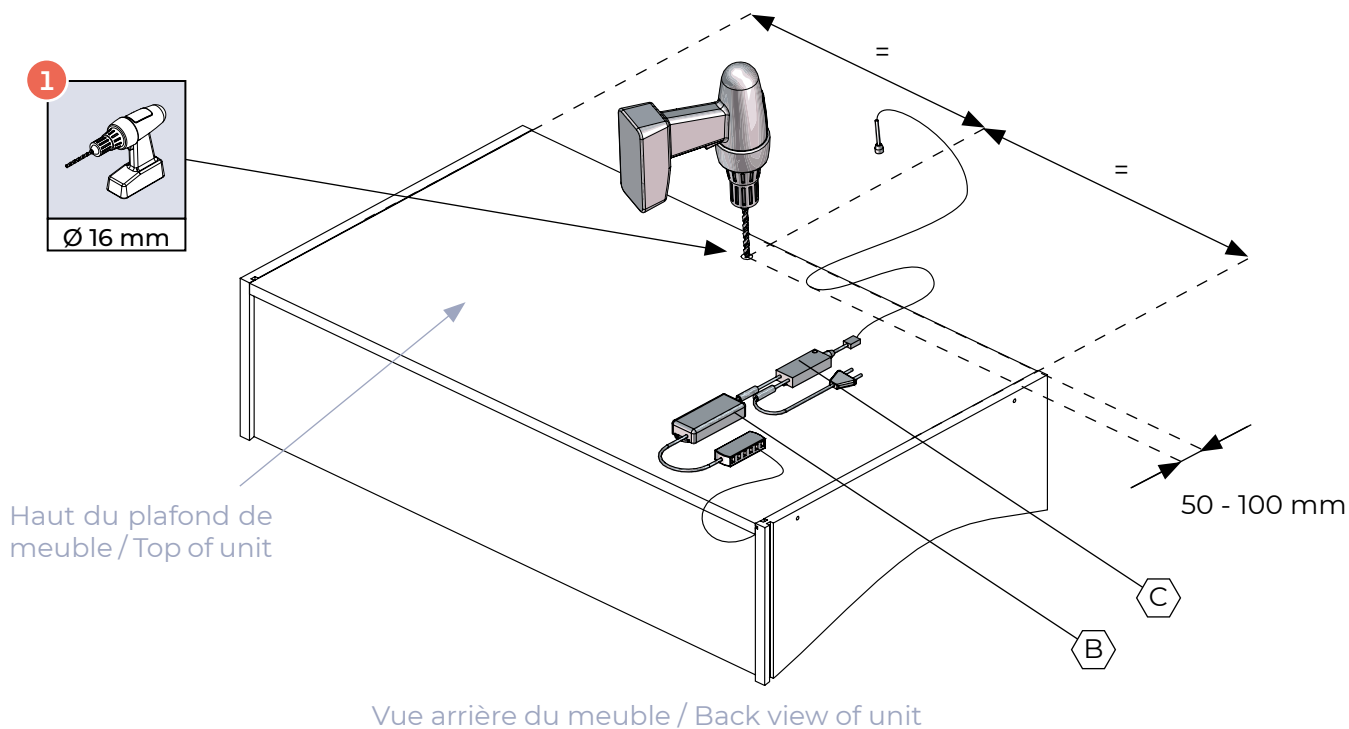

- 2 Insérer le détecteur dans le trou avec du silicone / Insert the motion detector with silicon glue
- 3 Visser l'alimentateur / Screw the power unit
- 4 Connecter / Connect
- 5 Alimentation : 220V / Power supply : 220V

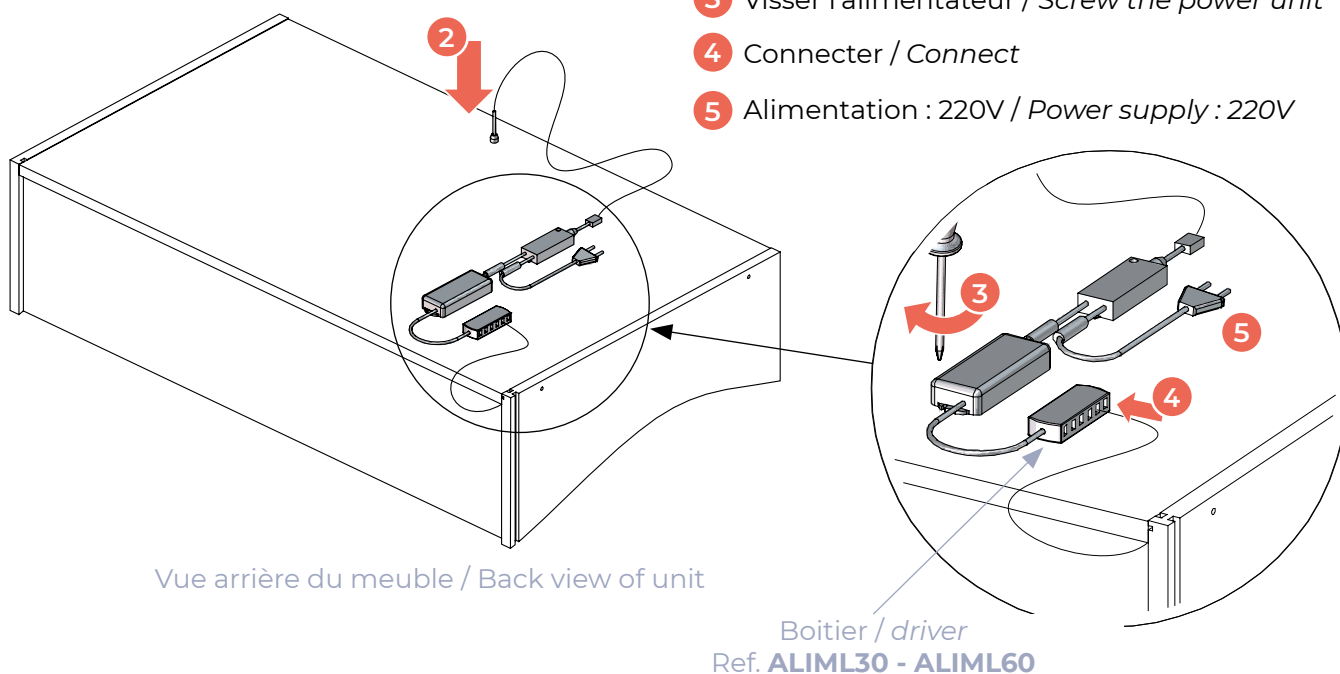

# F PROFIL LED À ENCASTRER / *SLOT-IN LED PROFILES*

QUINCAILLERIE / *HARDWARE*

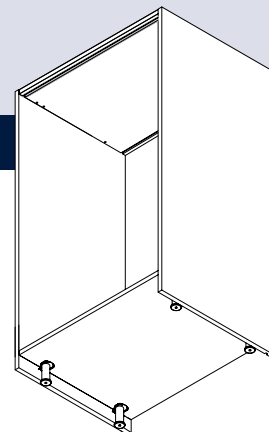

OU  
/  
OR



OU  
/  
OR



OU  
/  
OR



+

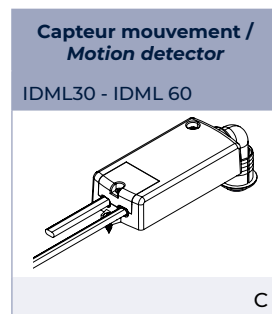
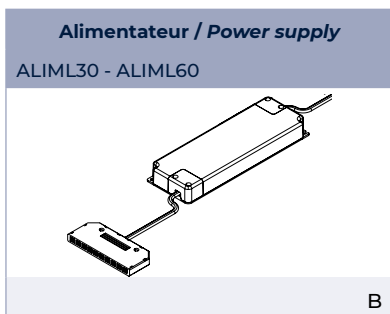

Références / References	<b>P09482262/ P09482270</b>	<b>P09482263/ P09482271</b>
Alimentation / Power supply	24 V	
Puissance par mètre / Power per meter	13 W	
Longueur / Length	80 cm → 120 cm	
Flux lumineux de la source / Light source luminous flux	1200 Lm	
Température de couleur / Colour temperature	3000°K	4000°K
Indice de protection / Index protection rating	IP20	
Isolation électrique / Electrical insulation	Classe III / Class III	



Ce luminaire intègre une source lumineuse de classe F. / This light integrates a class F light source.

P09482262	P09482270	P09482263	P09482271
 <b>FOURNIER</b> LS_SHG_01 A B C D E F G <b>12</b> kWh/1000h  2019/2015	 <b>FOURNIER</b> LS_SHG_02 A B C D E F G <b>13</b> kWh/1000h  2019/2015	 <b>FOURNIER</b> LS_SHG_01A A B C D E F G <b>12</b> kWh/1000h  2019/2015	 <b>FOURNIER</b> LS_SHG_02A A B C D E F G <b>13</b> kWh/1000h  2019/2015



La source lumineuse de ce luminaire n'est pas remplaçable. Lorsque la source lumineuse atteint sa fin de vie, le luminaire entier doit être remplacé. / The light source of this light is not replaceable. When the light source reaches the end of its life, the entire light must be replaced.



L'alimentateur de ce luminaire est remplaçable par un professionnel. / The driver of this light is replaceable by a professional.



**FR**  
Cet appareil  
et ses accessoires  
se recyclent



À DÉPOSER  
EN MAGASIN



À DÉPOSER  
EN DÉCHÈTERIE

The item should not be disposed of with household waste. Please take it to a collection point or an approved centre to ensure that it is recycled.

Points de collecte sur [www.quefairedemesdechets.fr](http://www.quefairedemesdechets.fr)  
Privilégiez la réparation ou le don de votre appareil !





2 Si nécessaire : préparation du dos / If necessary: back preparation

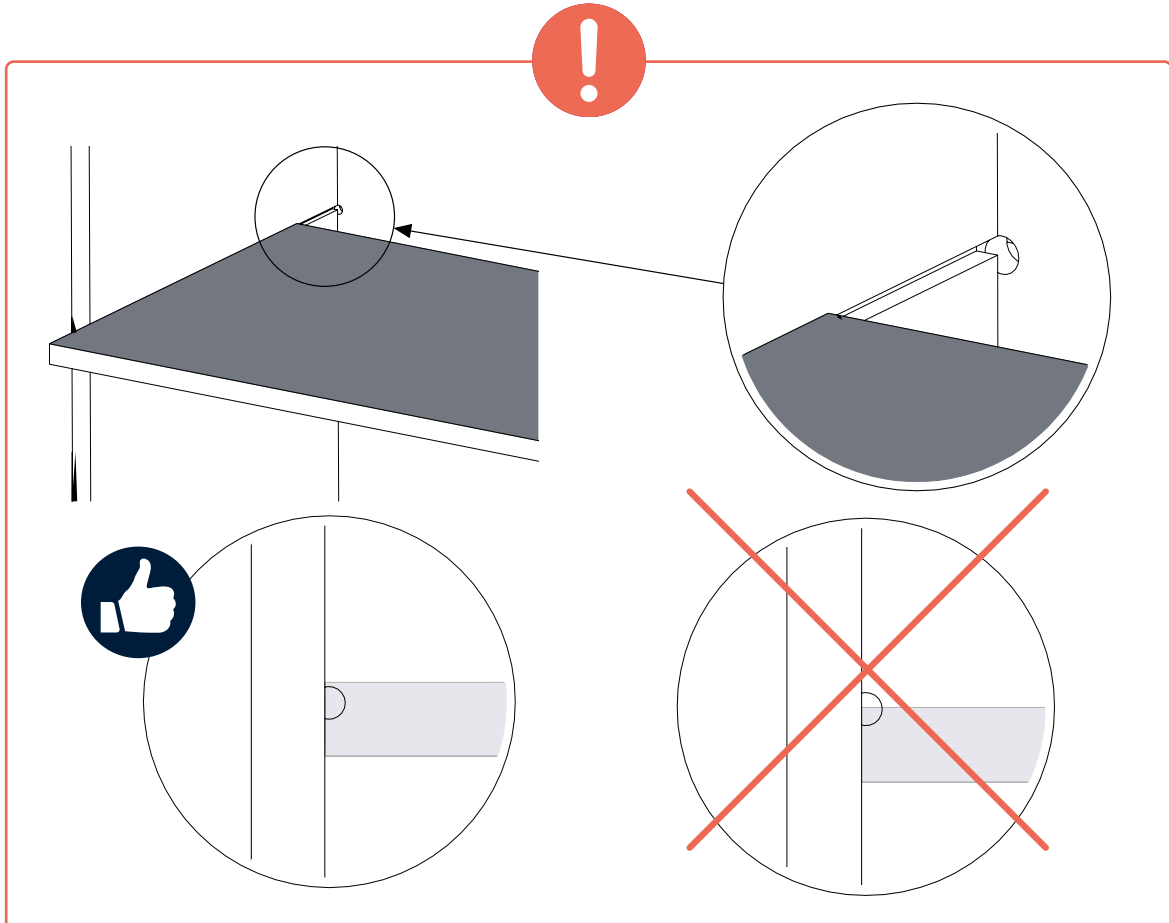
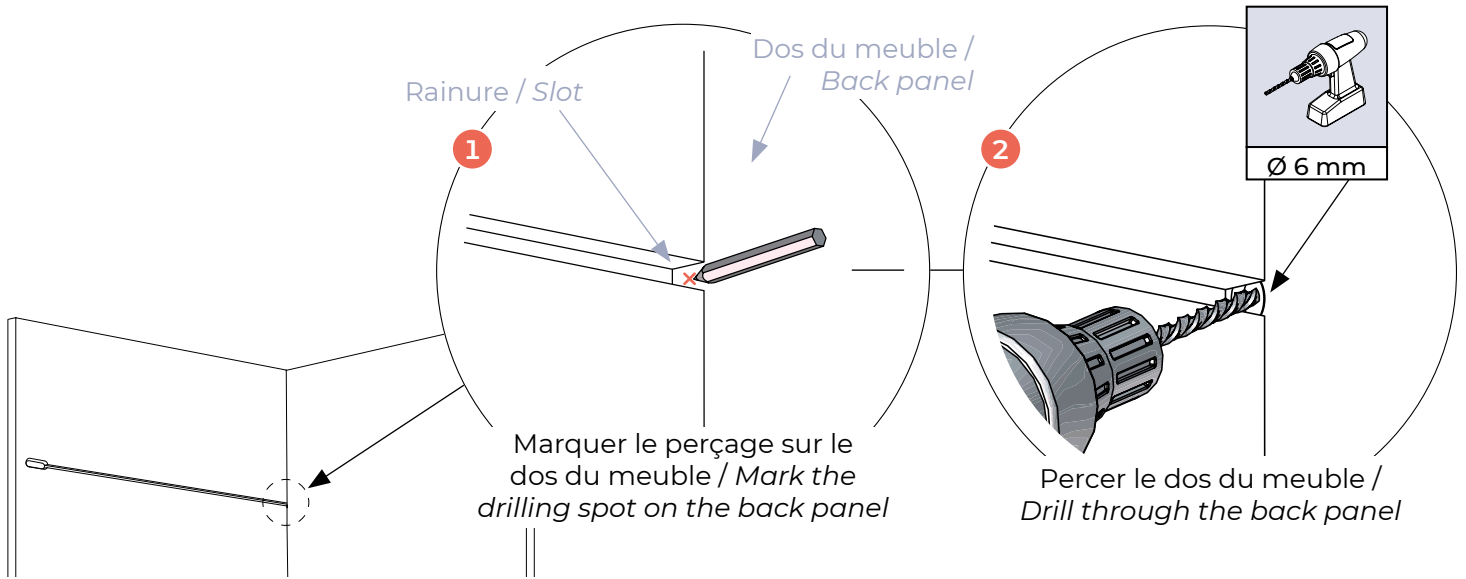

2

1 Déconnecter le cable de la barre / Disconnect electrical cable from LED bar

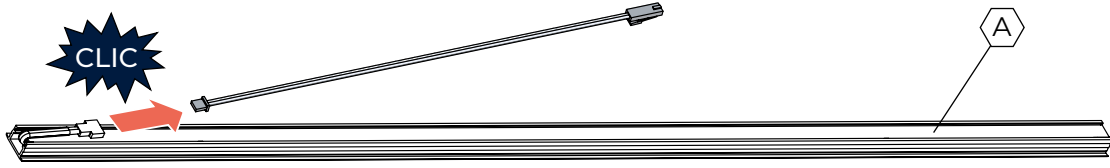

2

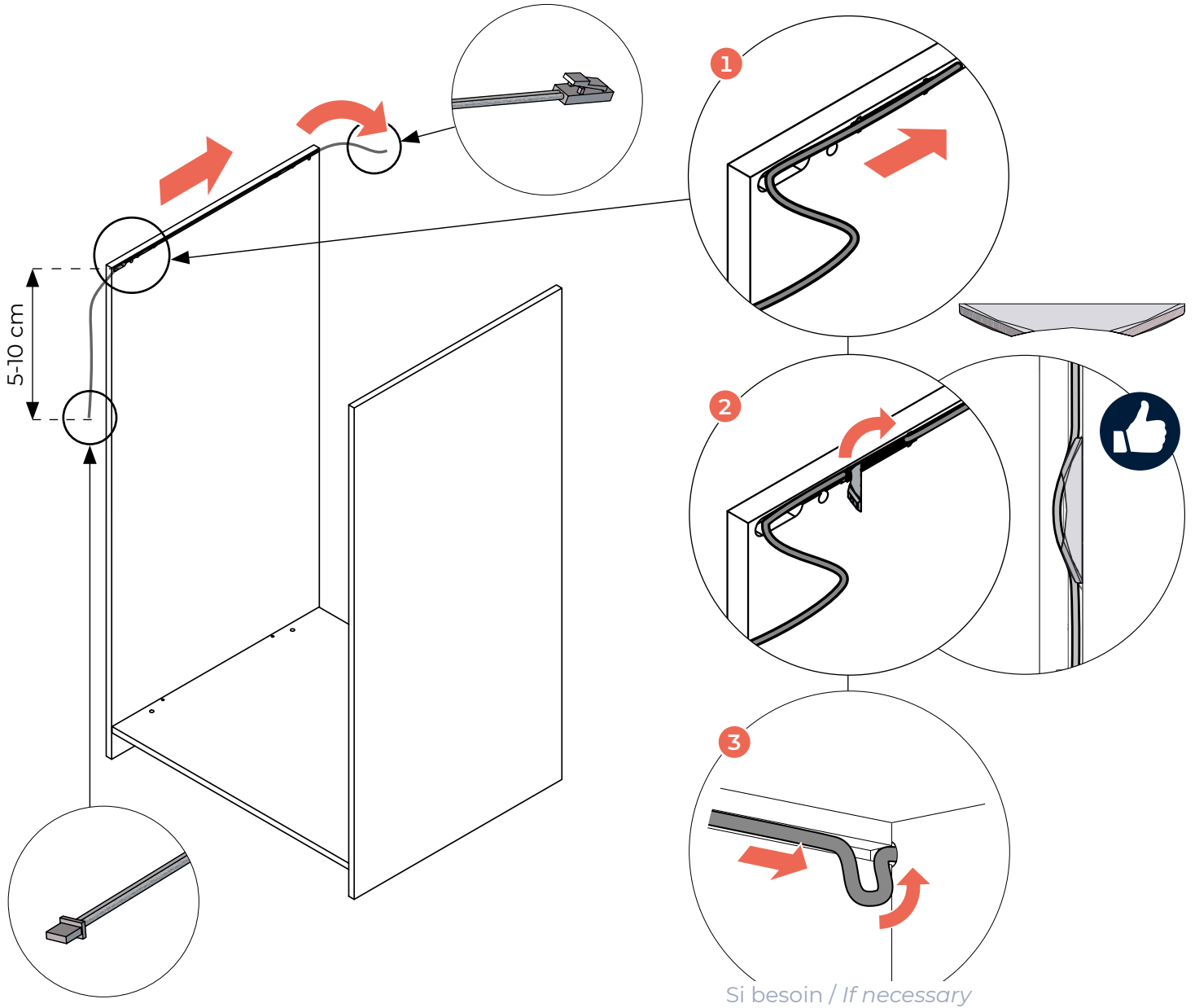

3

Monter le plafond /l'étagère/ Assemble unit's top/shelf

➔ **A** MONTAGE DE COLONNE / UNIT ASSEMBLY **5** p.18

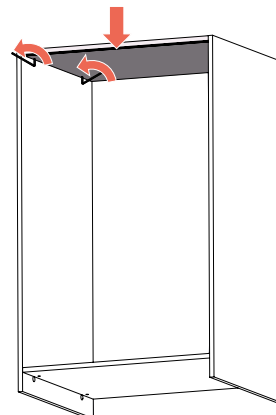

4

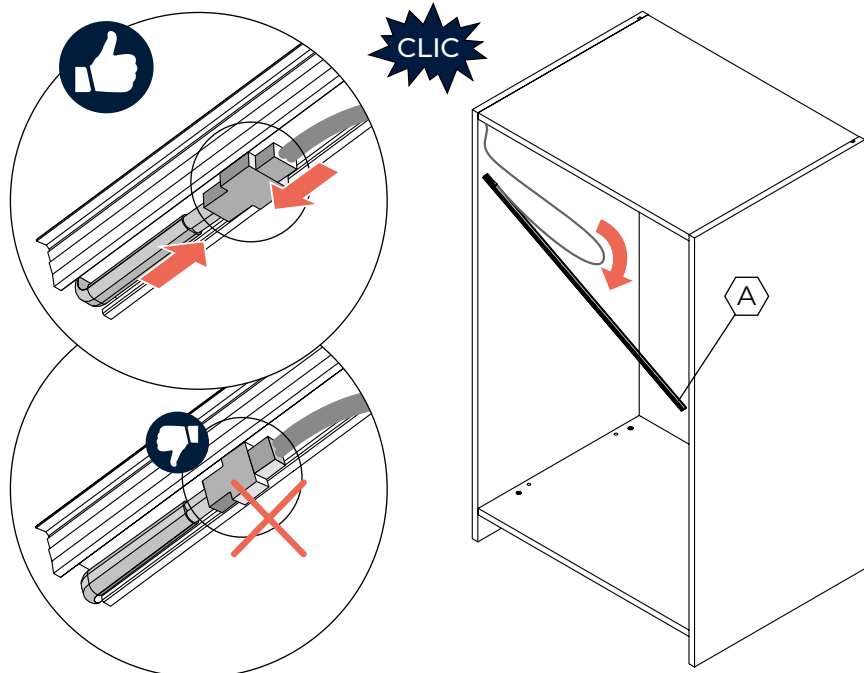

5

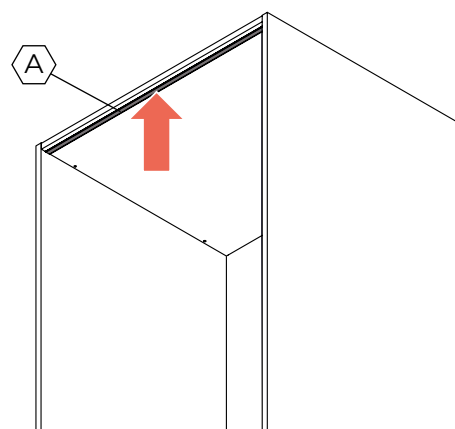

**i** Vous aurez peut-être besoin de serre-joints / Clamps may be needed

## 6 Branchement électrique / Electrical connection

**!** Le profil doit être installé par un électricien qualifié et câblé conformément aux exigences nationales en vigueur / Profile must be installed by a qualified electrician and wired according with the requirements of the respective country

### 1 Coupez l'alimentation générale / Cut off the general power supply

Conformément à la norme NF C 15-100, raccordez l'applique à l'alimentation électrique par l'intermédiaire d'un boîtier de raccordement non fourni (classe, IPXX). / According to standard NF C 15-100, connect the light to the power supply through a connection box not supplied (IPXX, class).

2

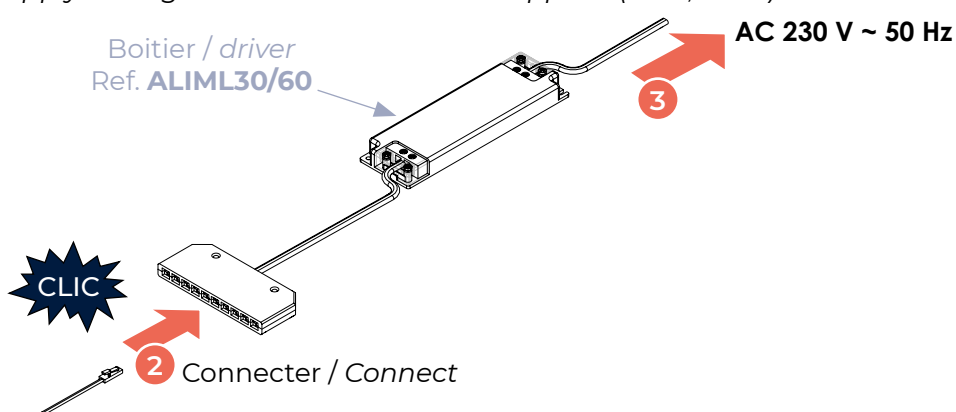

**i**

Le type et le nombre d'alimentateurs à utiliser pour votre installation dépend :

- Du nombre d'appareils à connecter
- De la puissance maximale cumulée des appareils électriques à connecter
- De l'étanchéité nécessaire /

The type and number of drivers to use for your installation depends on :

- The number of appliances to be connected
- The maximum cumulative power of the electrical appliances to be connected
- The required watertightness

7

## Branchement d'un accessoire LED avec détecteur de mouvement / Electrical connection of a LED device with motion detection

**?**

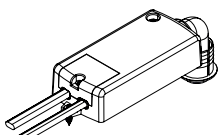

**E**

SPOT LED / LED SPOTS

**3**

p.37

# G PENDERIE (AVEC OU SANS LED) / WARDROBE (WITH OR WITHOUT LED PROFILES)

## SOMMAIRE / SUMMARY

### PENDERIE AVEC LED / WARDROBE WITH LED

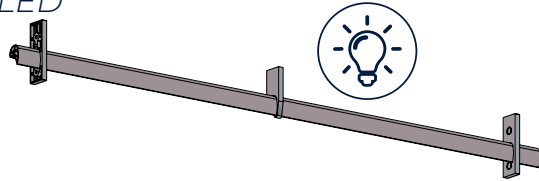

47

### PENDERIE SANS LED / WARDROBE WITHOUT LED

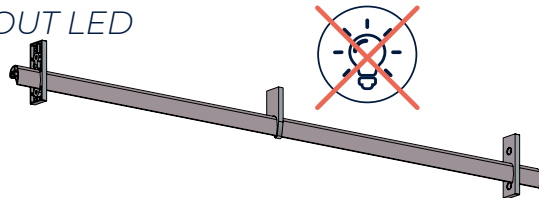

51

### RETOUR D'ANGLE / CORNER RETURN

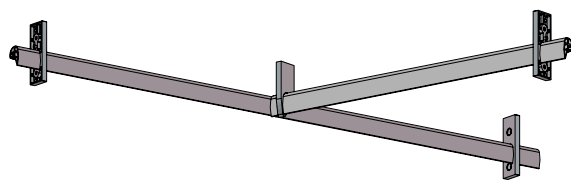

53

## 1 Barre de penderie avec LED (24V) / Wardrobe bar with LED (24V)

Ce luminaire intègre une source lumineuse de classe F. / This light integrates a class F light source.

Référence / Reference	<b>P31001055</b>
Alimentation / Power supply	24 V
Puissance de la source / Power per meter	5W par mètre / 5W per meter
Flux lumineux de la source / Light source luminous flux	480 Lm
Température de couleur / Colour temperature	4000°K
Indice de protection / Index protection rating	IP20
Isolation électrique / Electrical insulation	Classe III / Class III

**ENERGY**  
FOURNIER  
LS\_SHG\_08

A  
B  
C  
D  
E  
F  
G

**F**

5 kWh/1000h

2019/2015



La source lumineuse de ce luminaire n'est pas remplaçable. Lorsque la source lumineuse atteint sa fin de vie, le luminaire entier doit être remplacé. / The light source of this light is not replaceable. When the light source reaches the end of its life, the entire light must be replaced.



L'alimentateur de ce luminaire est remplaçable par un professionnel. / The driver of this light is replaceable by a professional.

**FR**  
Cet appareil et ses accessoires se recyclent

À DÉPOSER EN MAGASIN OU À DÉPOSER EN DÉCHÈTERIE

The item should not be disposed of with household waste. Please take it to a collection point or an approved centre to ensure that it is recycled.

Points de collecte sur [www.quefairedemesdechets.fr](http://www.quefairedemesdechets.fr)  
Privilégiez la réparation ou le don de votre appareil !

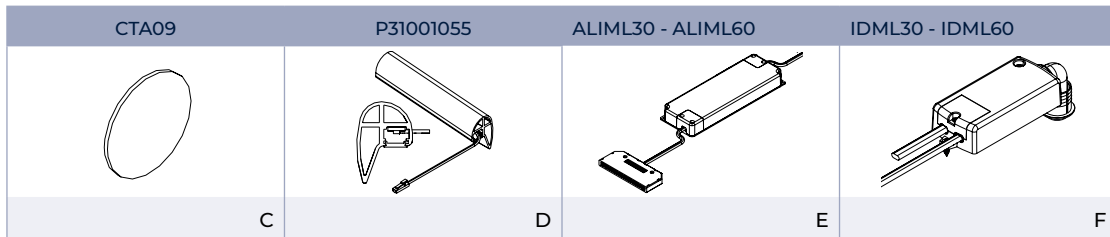
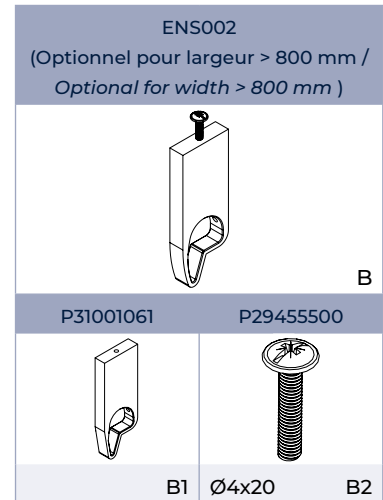
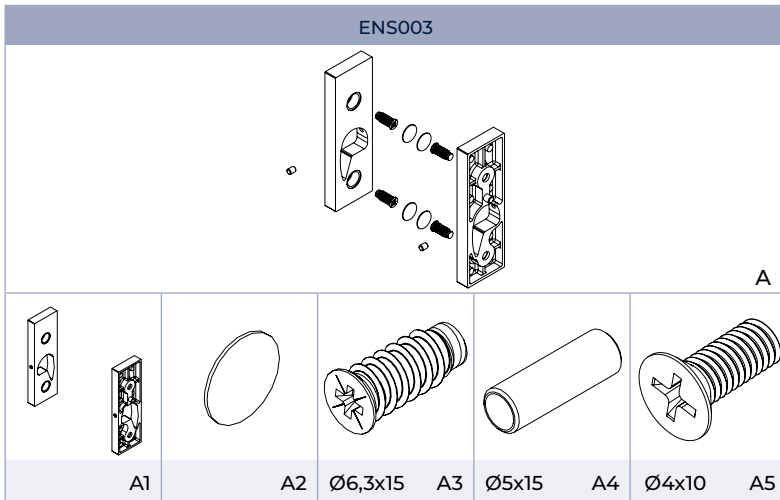

1 Si nécessaire : préparation du dos du meuble / If necessary: back panel preparation



**F** PROFIL LED À ENCASTRER /  
SLOT-IN LED PROFILE

2

p.41

2 Si nécessaire : découpe de la barre LED / If necessary: LED bar cut

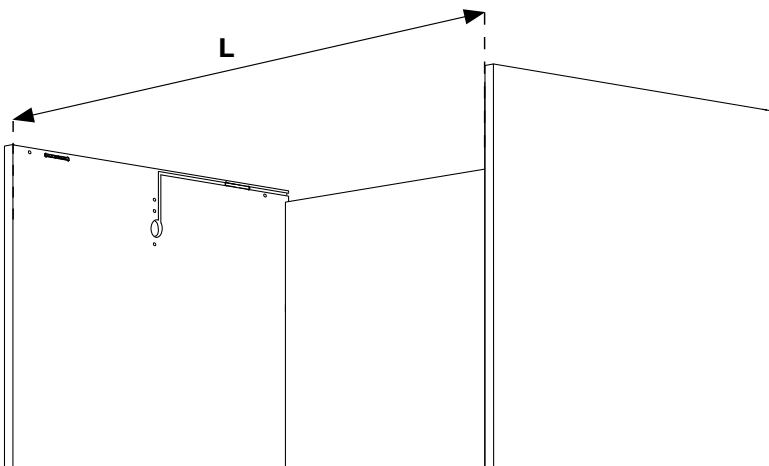

Largeur **L** du profil = largeur intérieure de l'étagère /  
**L** profile length = inside width of unit

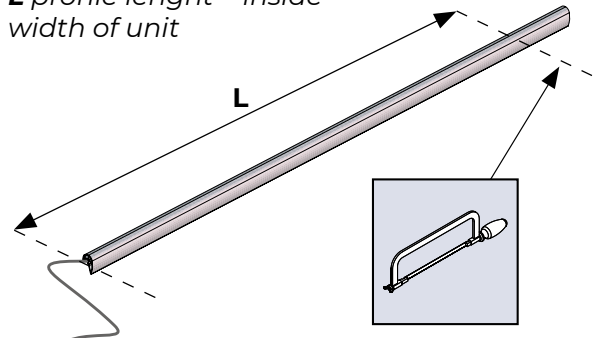

La barre LED et le profil peuvent être découpés  
assemblés / LED bar and profile can be  
assembled and cut

3 Scotcher la barre de penderie au côté du meuble / Temporarily tape the bar to unit's side

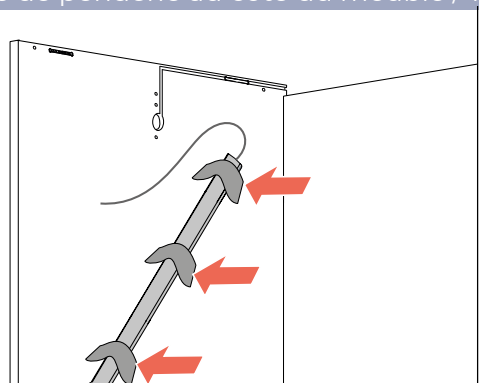

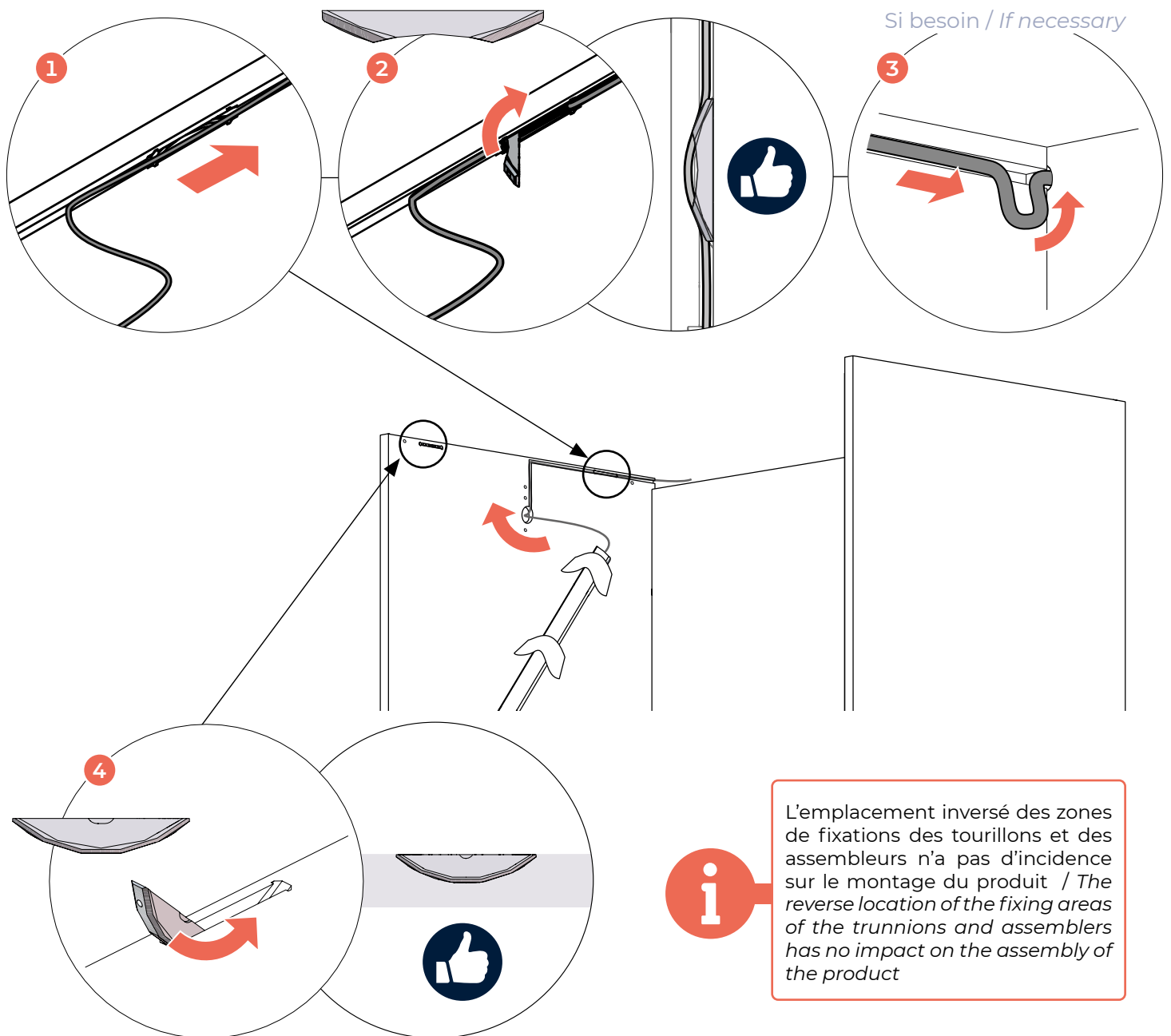

L'emplacement inversé des zones de fixations des tourillons et des assembleurs n'a pas d'incidence sur le montage du produit / The reverse location of the fixing areas of the trunnions and assemblers has no impact on the assembly of the product

5 Monter le plafond /l'étagère/ Assemble unit's top/shelf

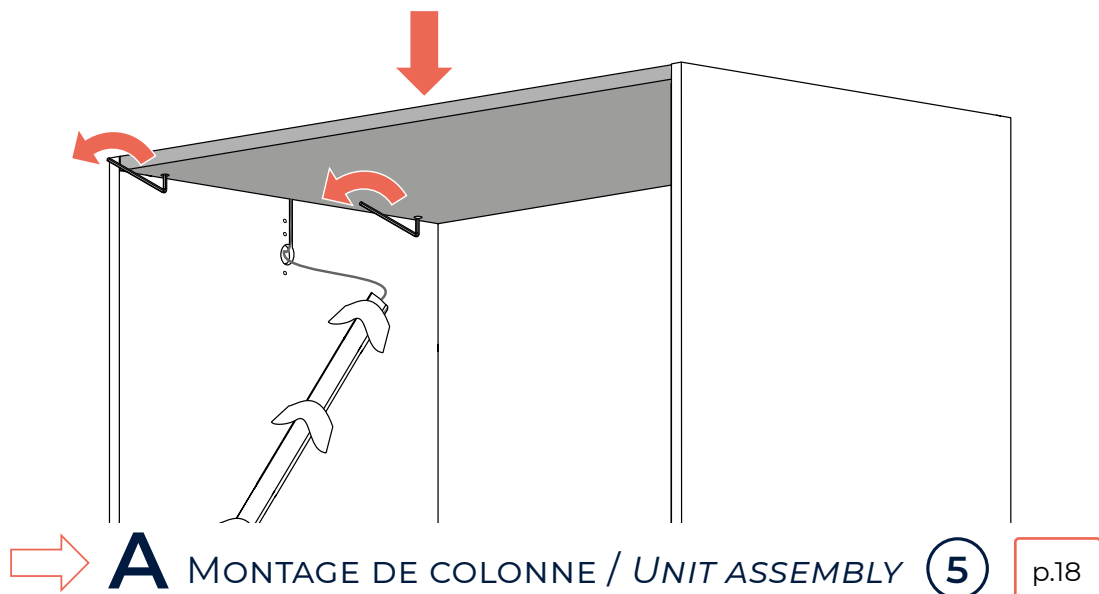

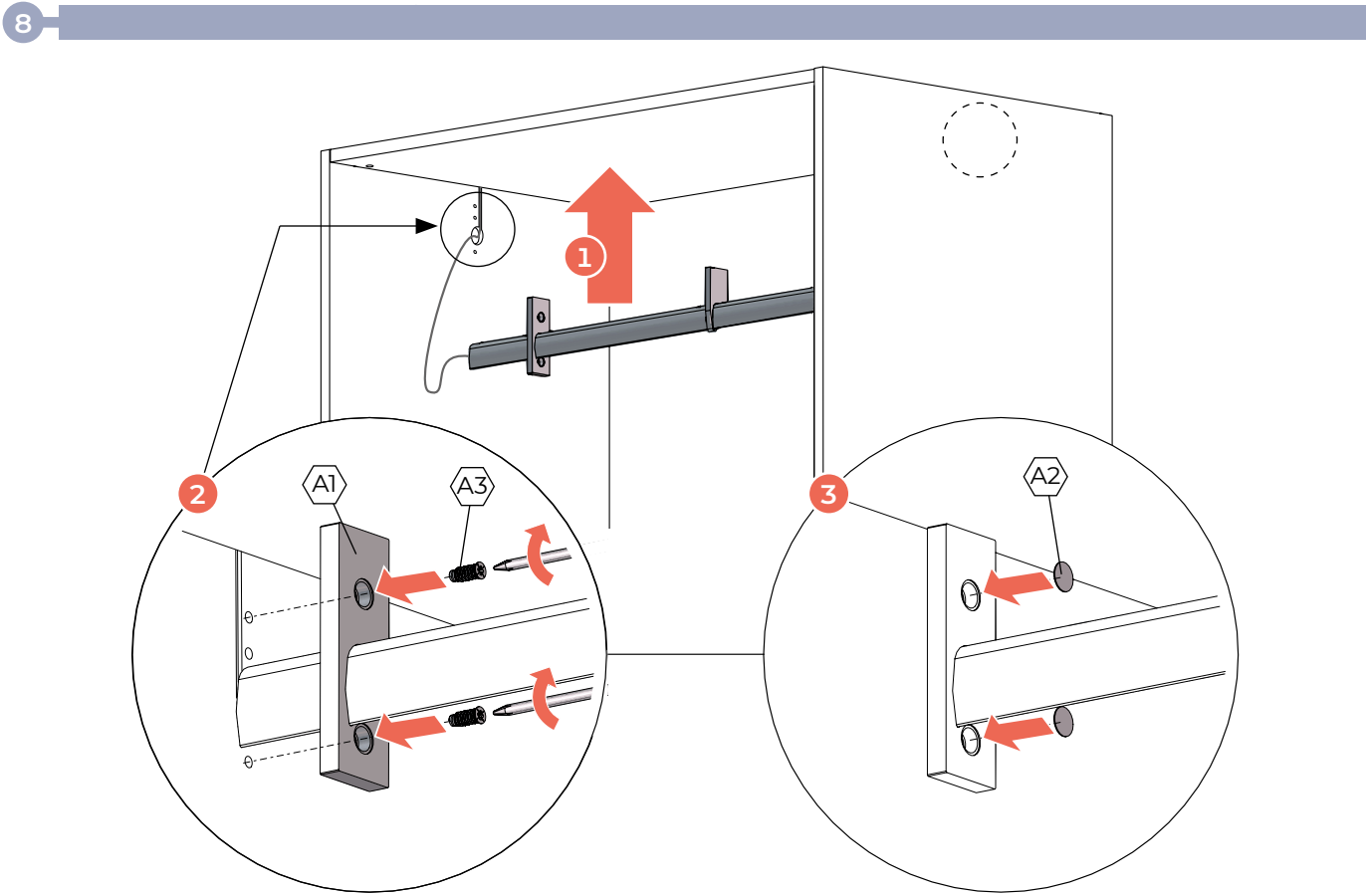
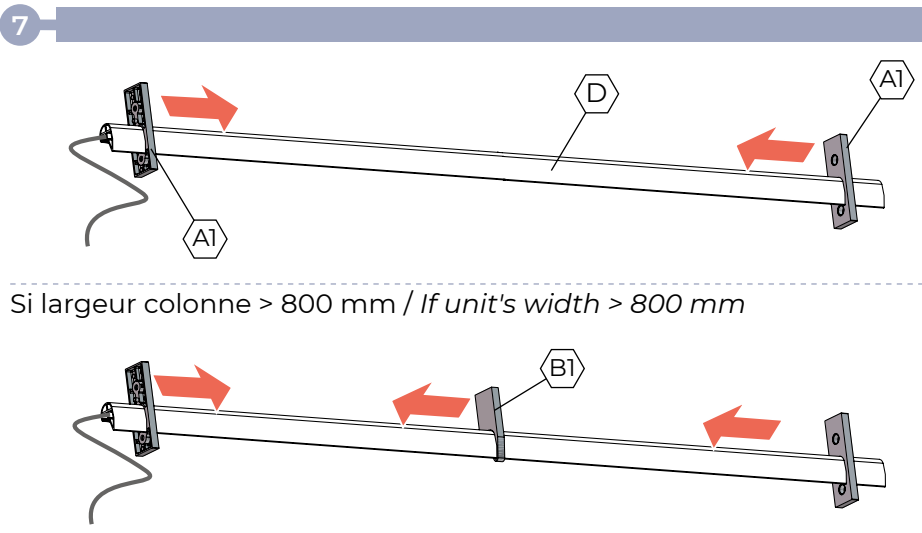
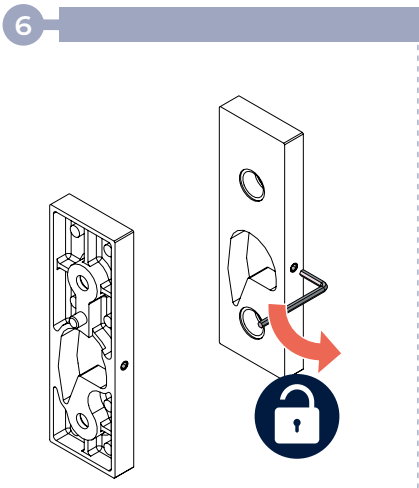

Si deux barres face à face / If two bars are facing each other through the unit

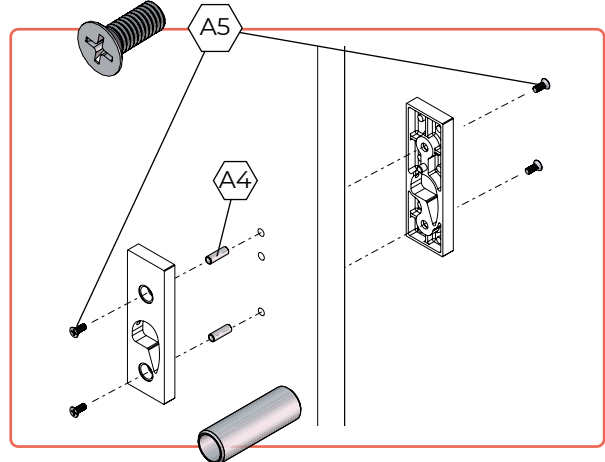
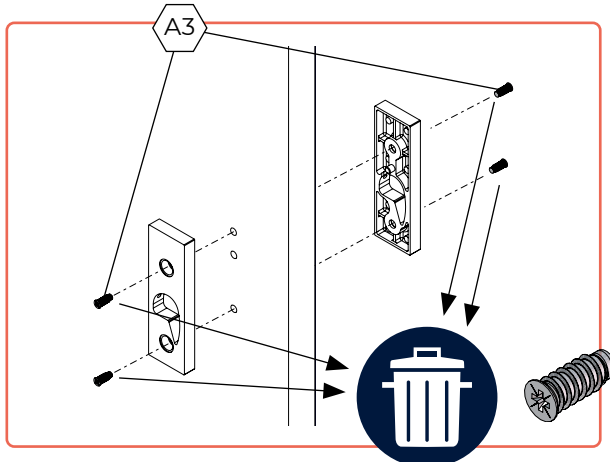

Vue arrière / Back view

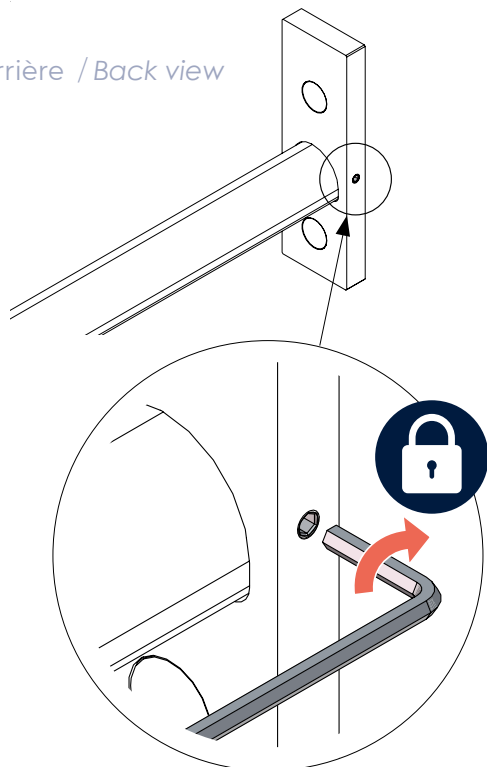

Haut de l'étagère ou du meuble / Top of the shelf or unit

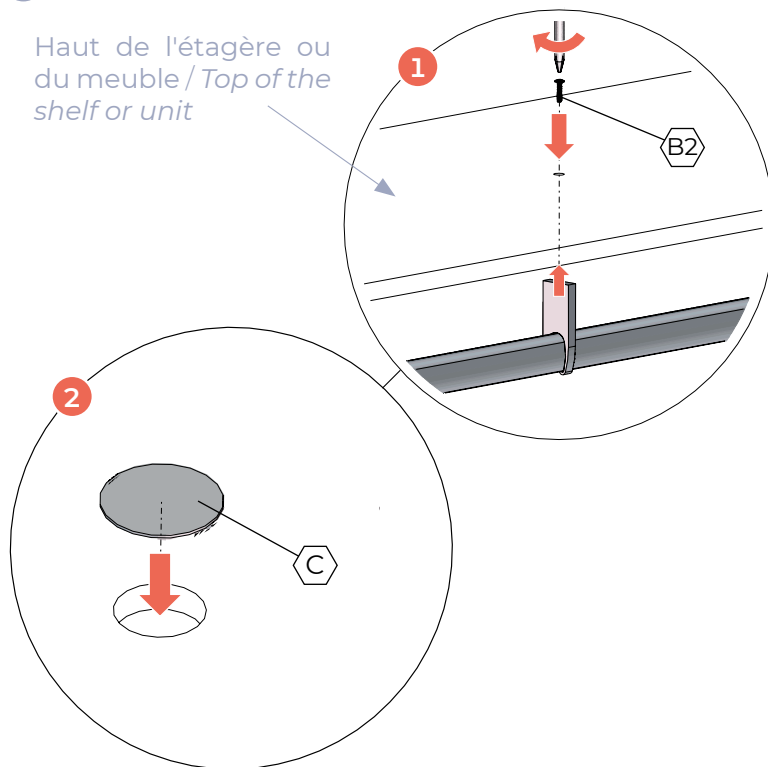

10 Branchement électrique / Electrical connection

**!** Le profil doit être installé par un électricien qualifié et câblé conformément aux exigences nationales en vigueur / Profile must be installed by a qualified electrician and wired according with the requirements of the respective country

1 Coupez l'alimentation générale / Cut off the general power supply

Conformément à la norme NF C 15-100, raccordez l'applique à l'alimentation électrique par l'intermédiaire d'un boîtier de raccordement non fourni (classe, IPXX). / According to standard NF C 15-100, connect the light to the power supply through a connection box not supplied (IPXX, class).

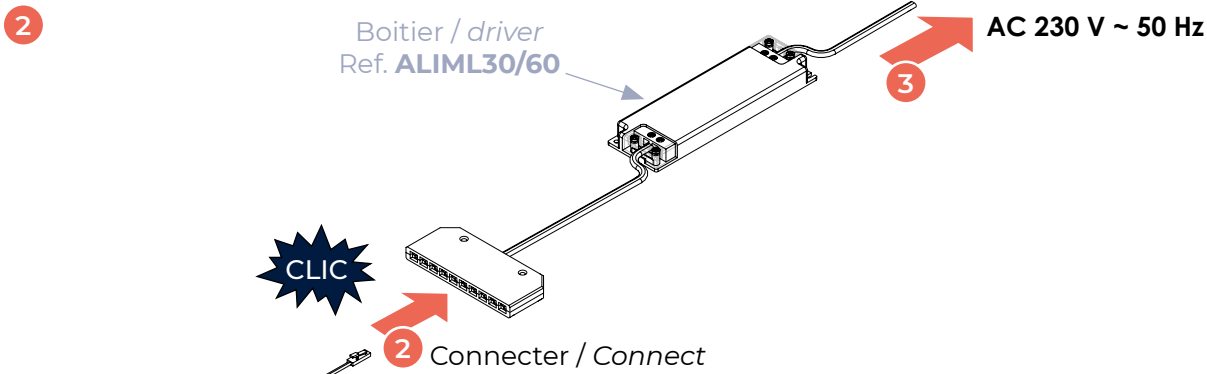

**i** Le type et le nombre d'alimentateurs à utiliser pour votre installation dépend :

- Du nombre d'appareils à connecter
- De la puissance maximale cumulée des appareils électriques à connecter
- De l'étanchéité nécessaire /

The type and number of drivers to use for your installation depends on :

- The number of appliances to be connected
- The maximum cumulative power of the electrical appliances to be connected
- The required watertightness

11 Branchement d'un accessoire LED avec détecteur de mouvement / Electrical connection of a LED device with motion detection



2

Penderie sans LED / Wardrobe without LED

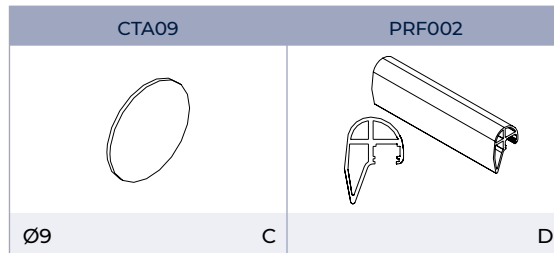
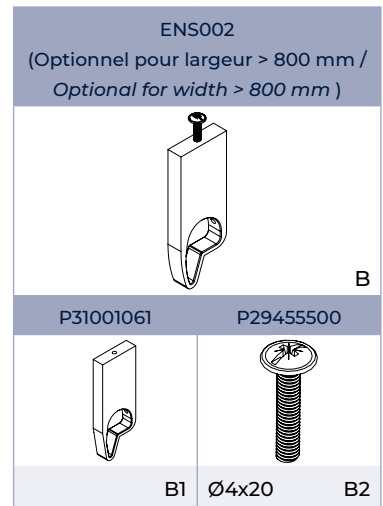
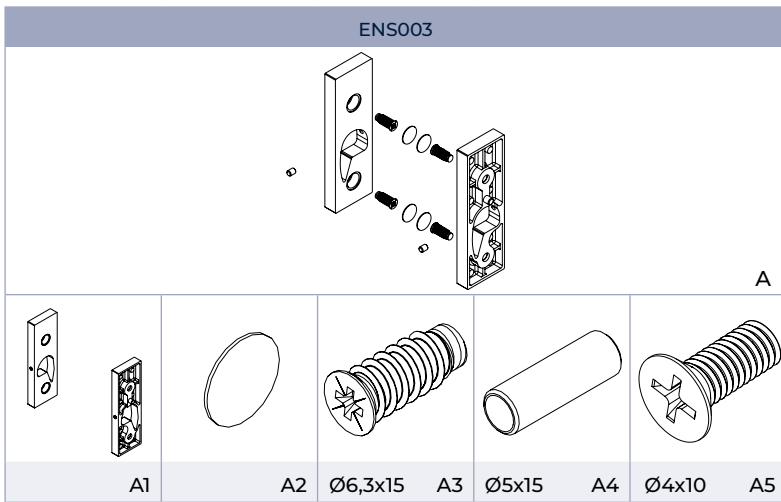

1

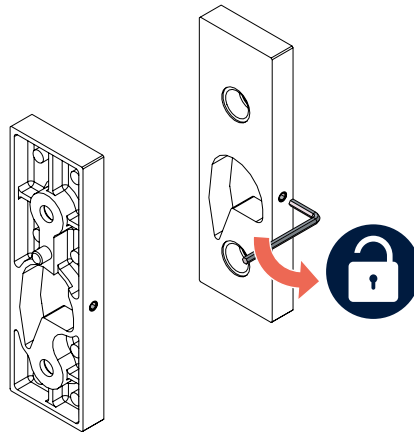

2

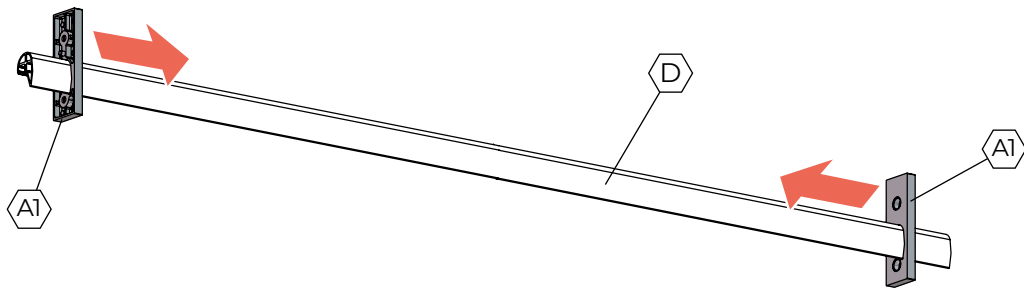

Si largeur colonne > 800 mm / If unit's width > 800 mm

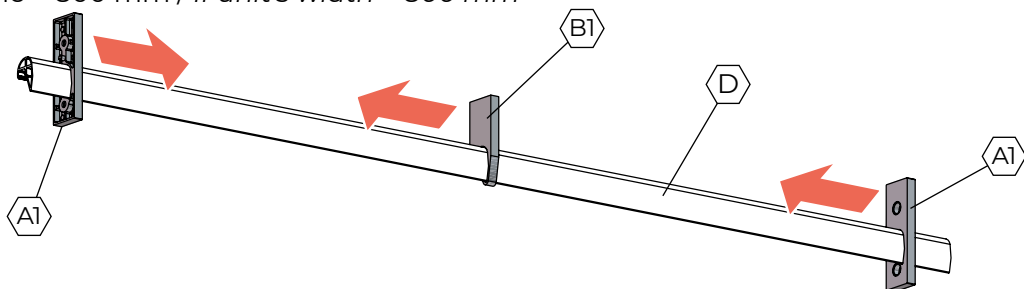

3

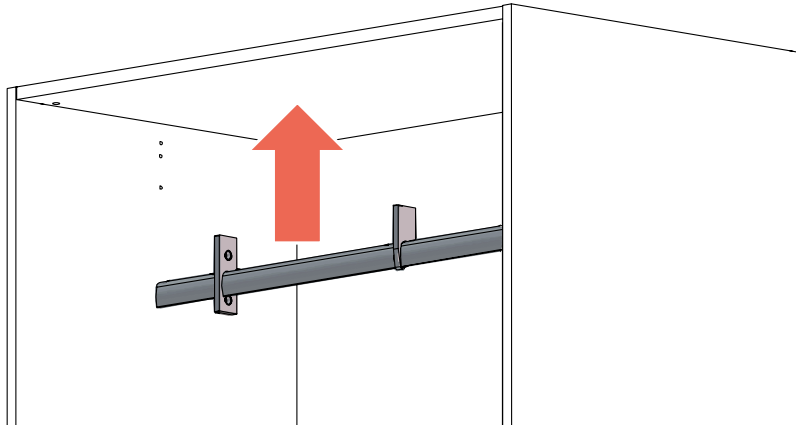

4

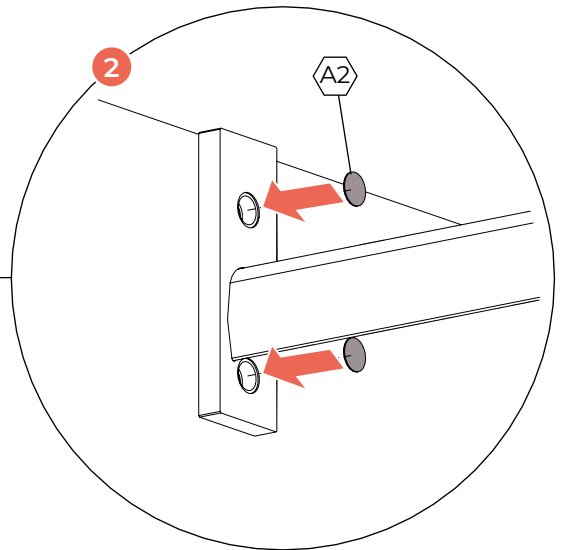
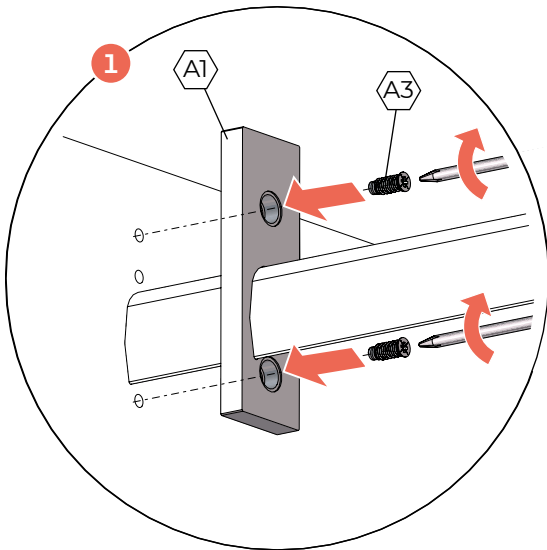

Si deux barres face à face / If two bars are facing each other through the unit

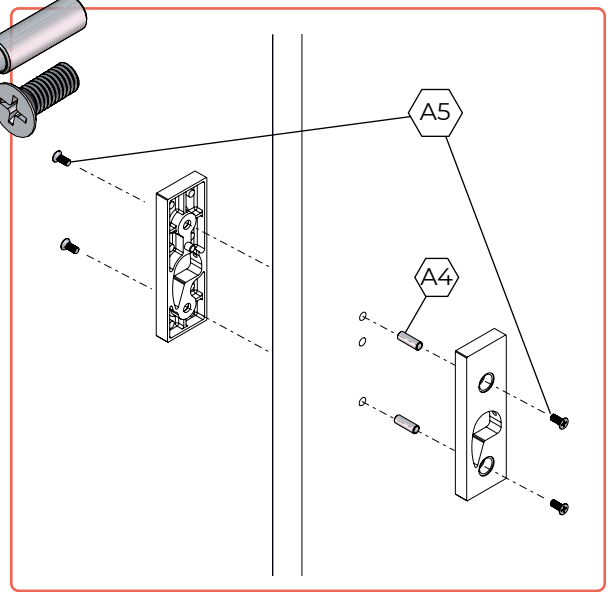
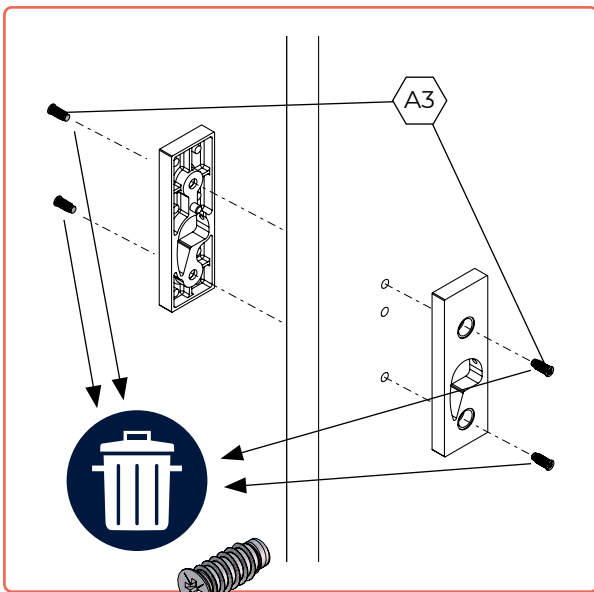

5



1

9

p.48

i

Si largeur colonne > 800 mm / If unit's width > 800 mm



1

i

p.48

### 3 Retour d'angle / Corner unit

1

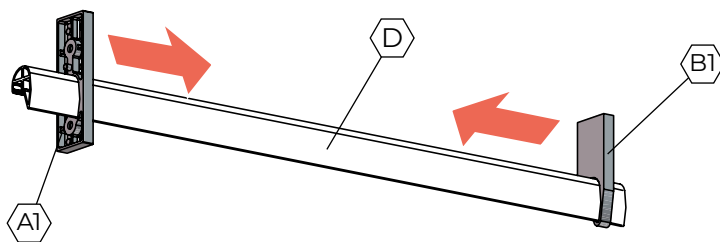

2

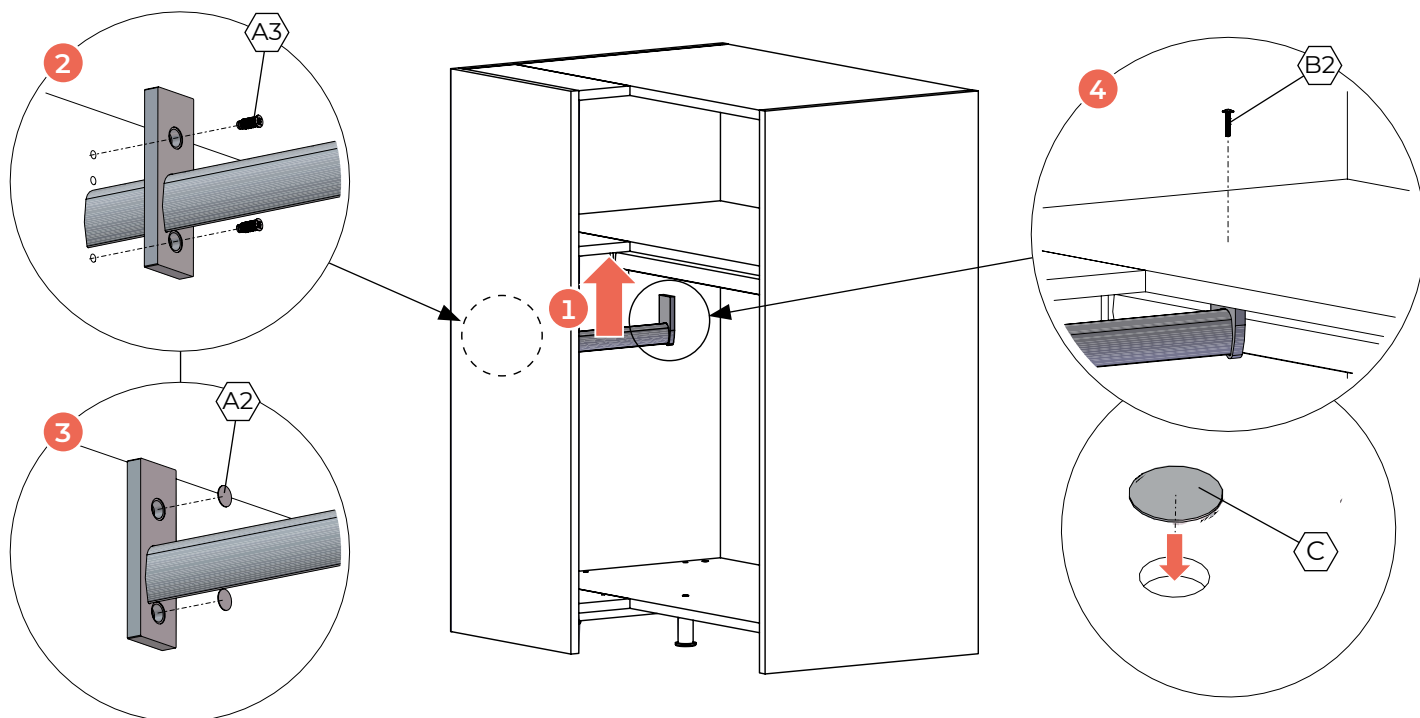

3

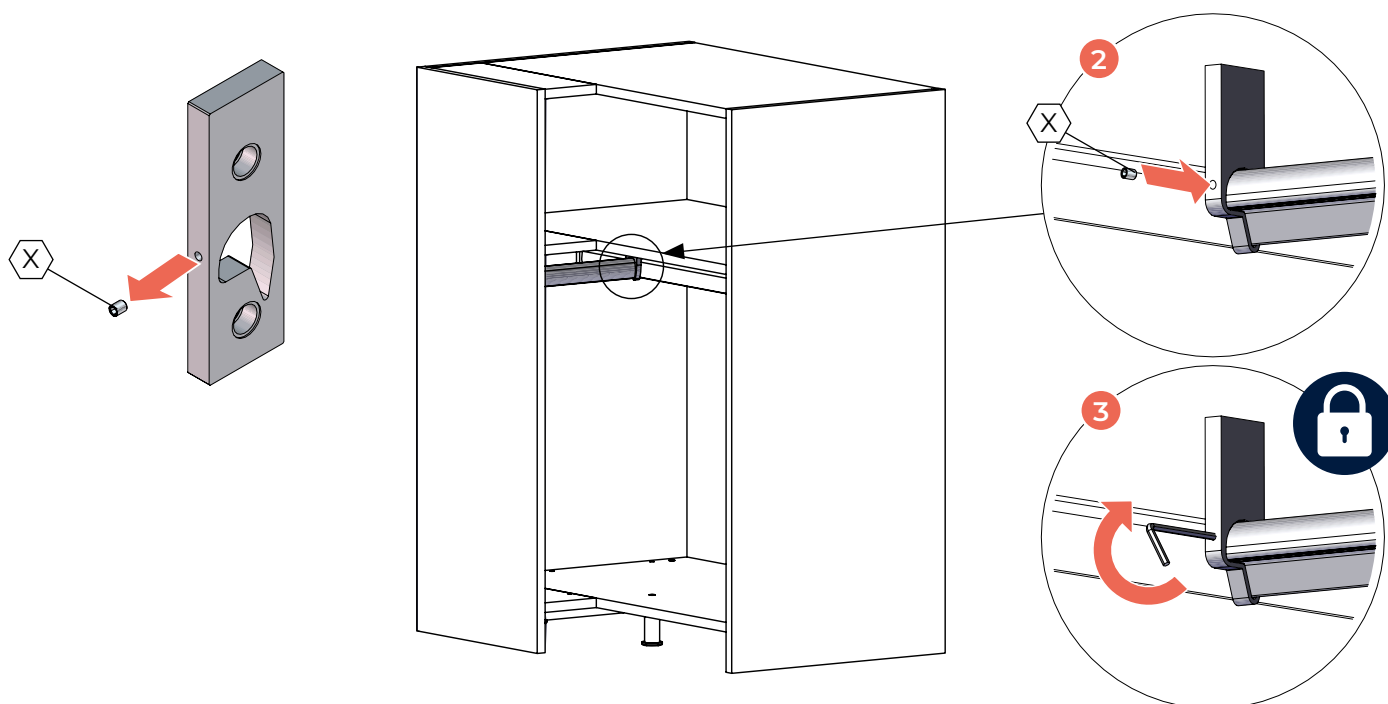

# 4

## PANNEAUX ET FINITIONS PANELS AND FINISHING TOUCHES

### A MASQUAGE DES PERÇAGES / DRILLS MASKING

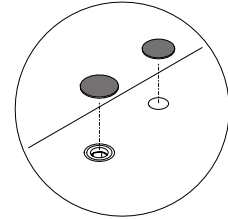

53

### B FILLER / FILLER

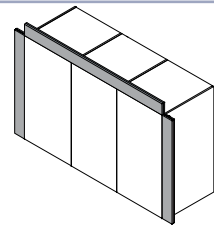

54

### C SOCLE / PLINTH

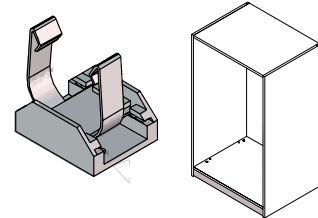

57

### D PANNEAU DÉCO MIROIR / DECORATIVE MIRROR PANEL

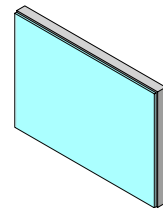

58

### E PERÇAGES POUR POIGNÉES SUR CHANTS / DRILLINGS FOR HANDLES ON UNIT'S EDGES

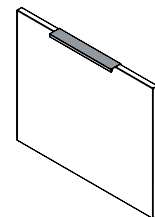

61

### F TOUCHE-LÂCHE MANUEL POUR FAÇADES / MANUAL PUSH BUTTON FOR FACADES

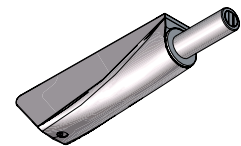

62

OUTILLAGE NON FOURNI / NOT SUPPLIED

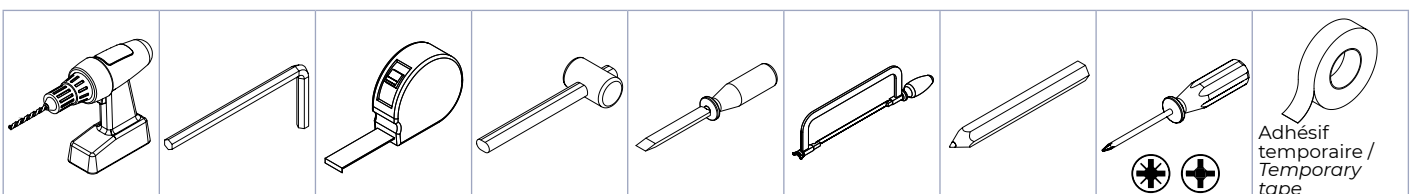

Adhésif temporaire /  
Temporary tape

# A MASQUAGE DES PERÇAGES / DRILLS MASKING

QUINCAILLERIE / HARDWARE



CTA20	CTA13	CTA09
Ø20 A	Ø13 B	Ø9 C

1

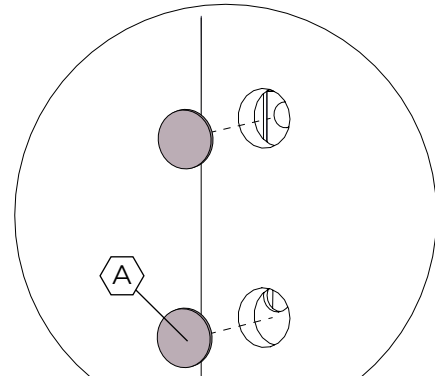
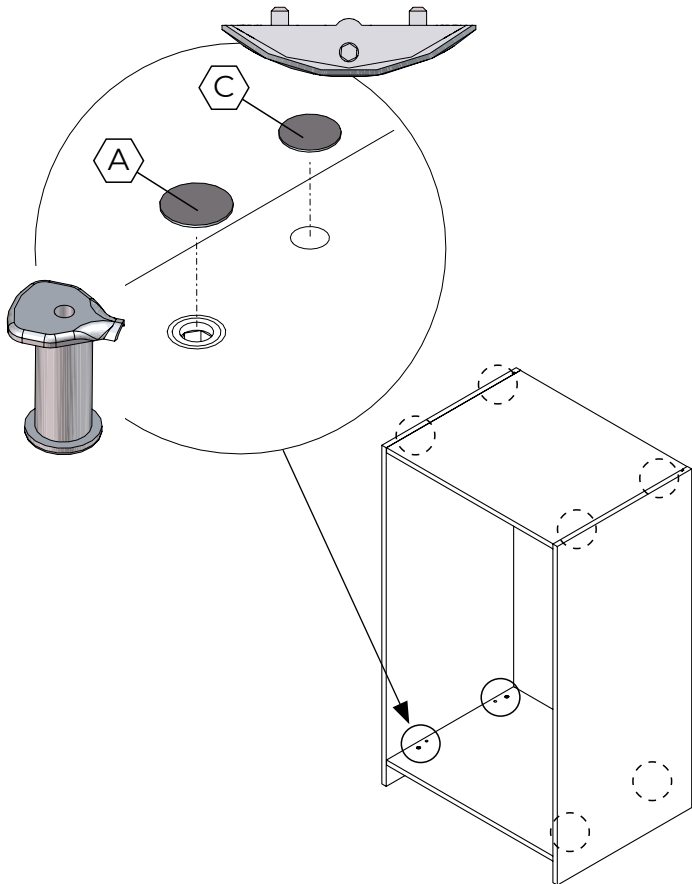

Perçages mécanismes d'accroche /  
Hanging mechanism drillings

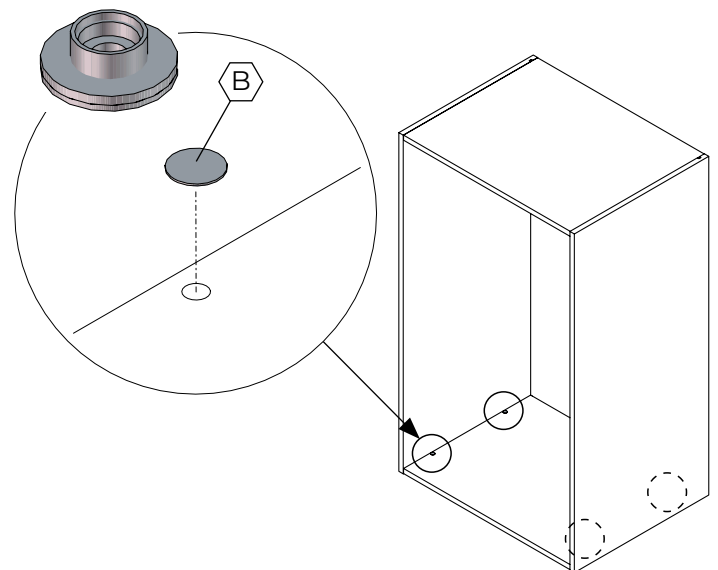
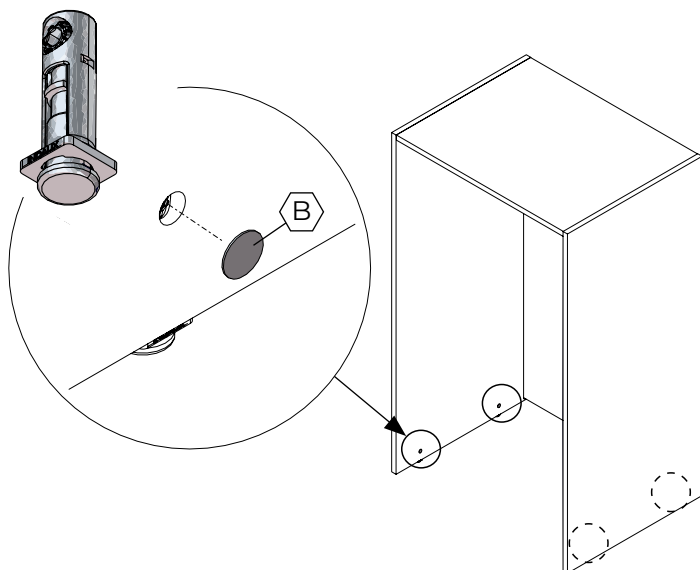
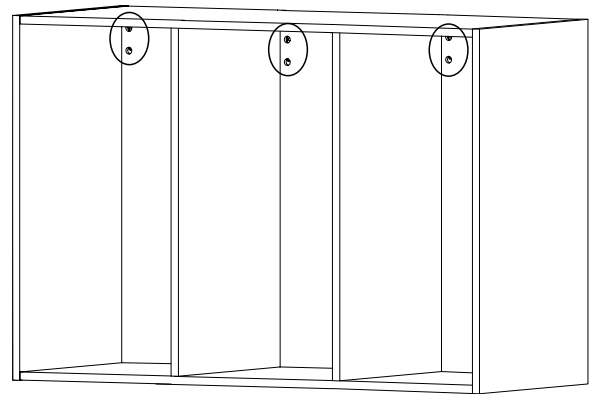

# B FILLER / FILLER

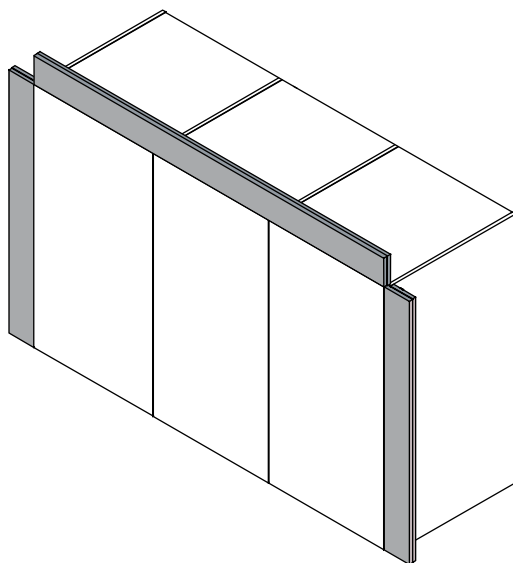

Le montage est symétrique d'un côté et de l'autre du meuble / Assembly is symmetrical on either side of the unit

## GLOSSAIRE / GLOSSARY

1	Filler de corps / Unit filler	2	Filler de façade / Door filler
---	-------------------------------	---	--------------------------------

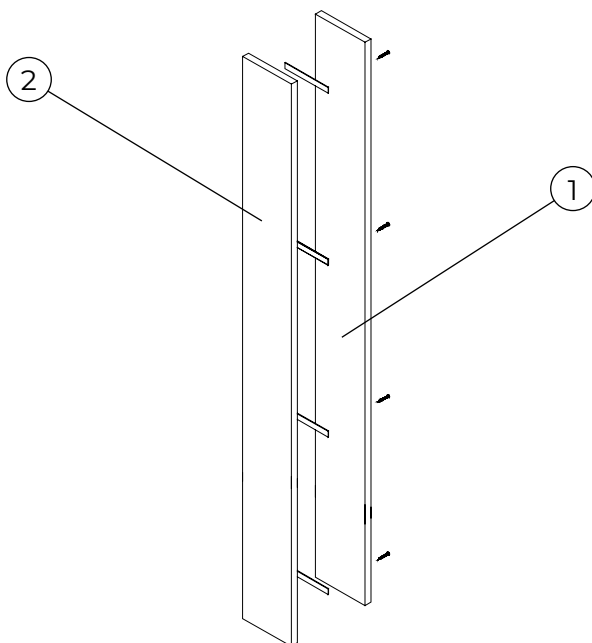

## QUINCAILLERIE / HARDWARE

P09473256	P09455008
A	Ø4x30 B

1

1

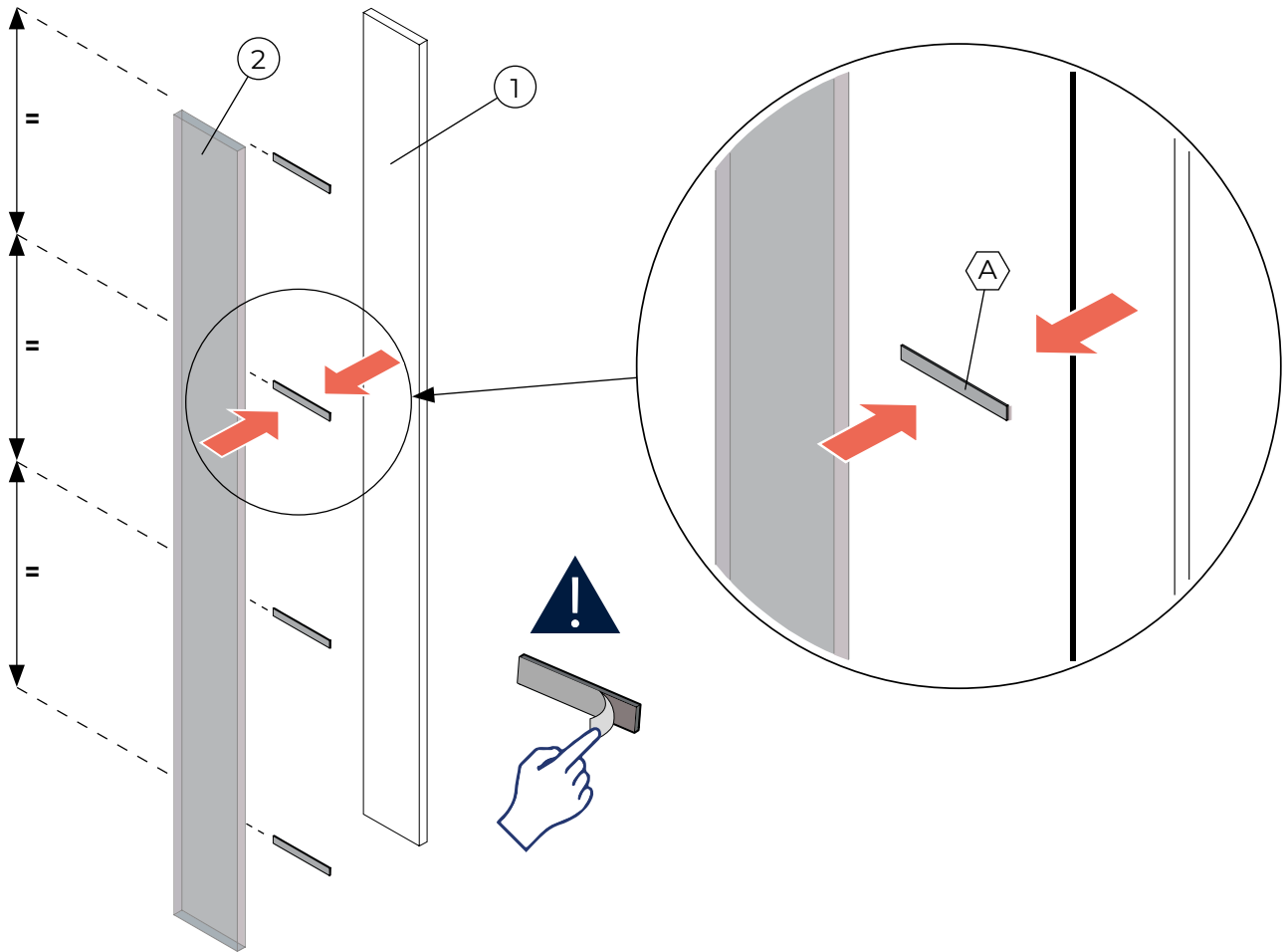

2

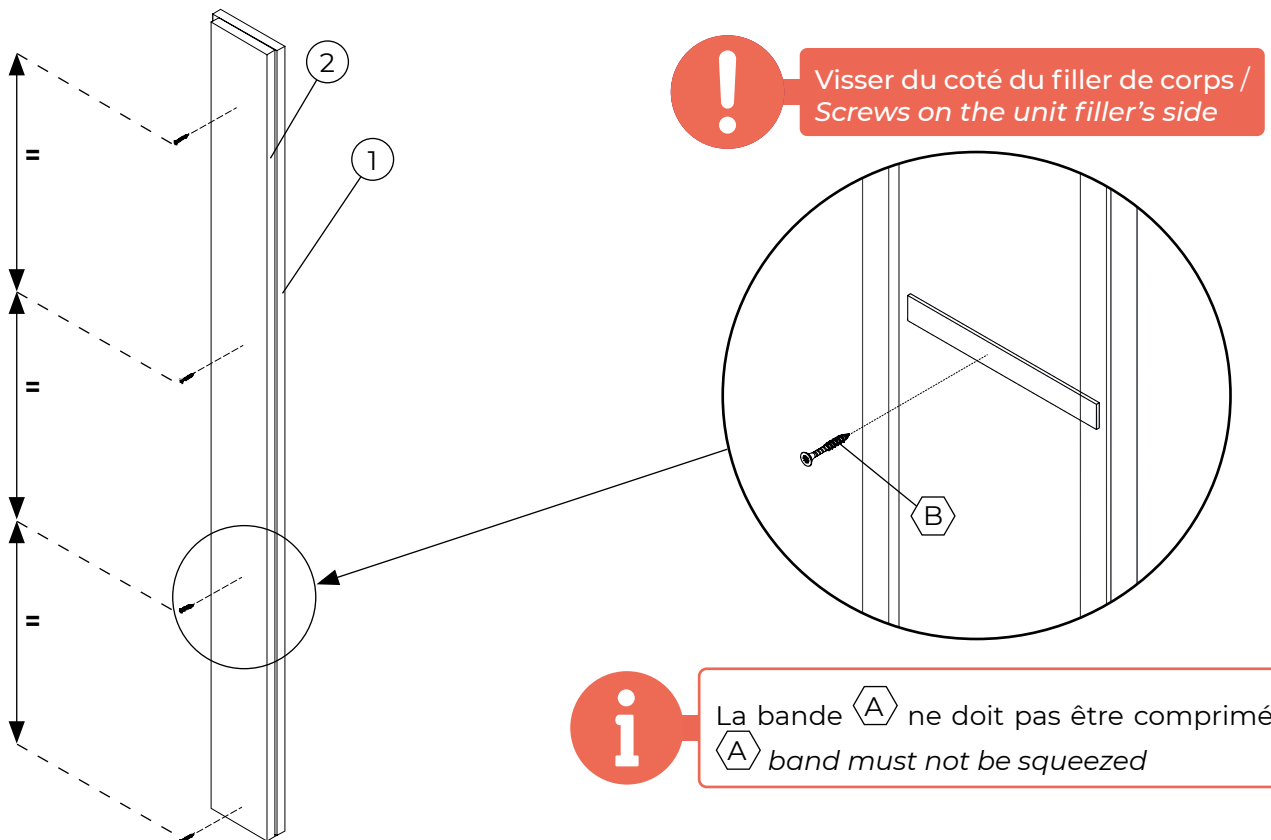

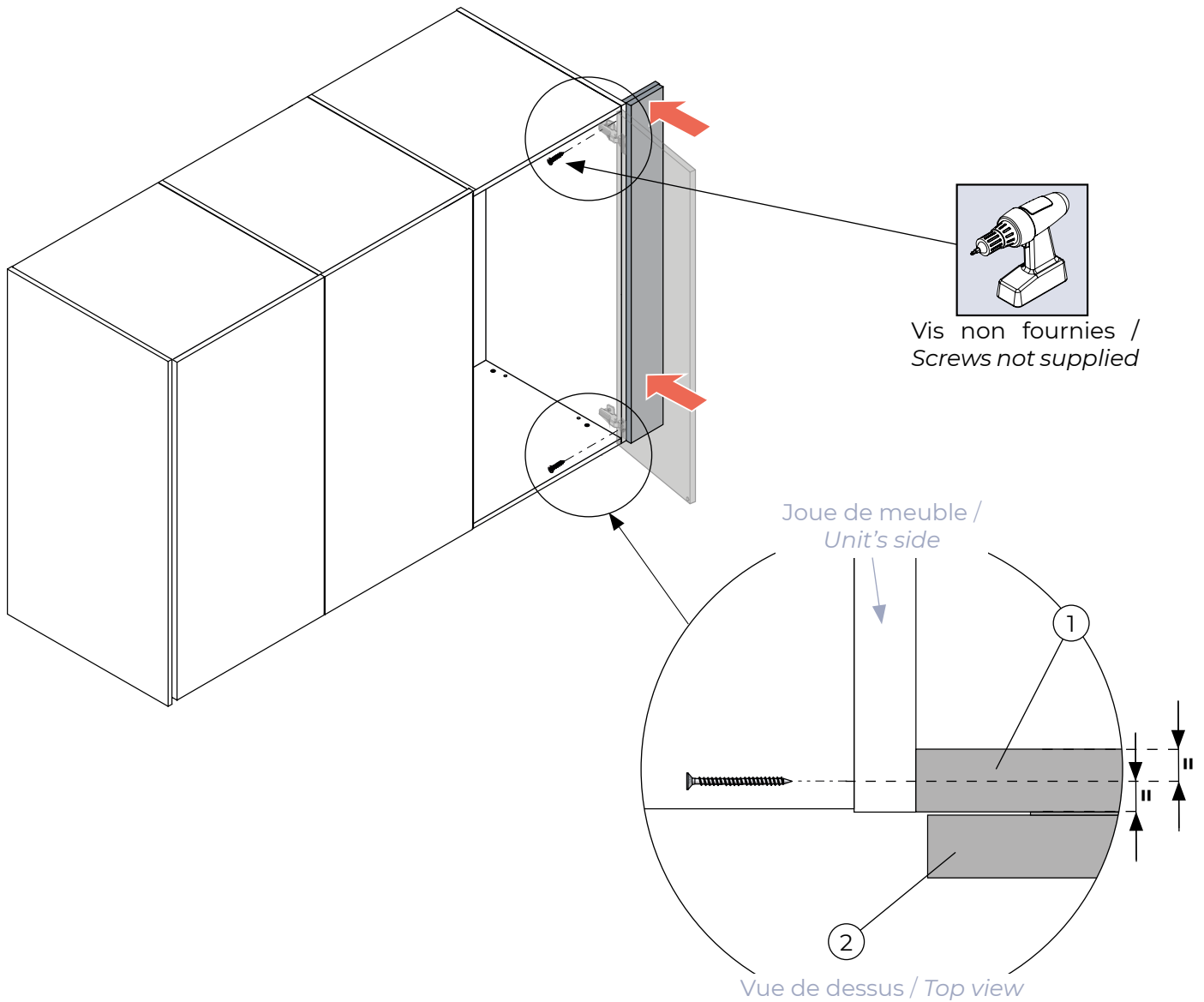

**Astuces : / Tips:**

Cacher les vis sous les charnières de portes ou derrière une étagère amovible /  
Hide screws under door hinges or adjustable shelf

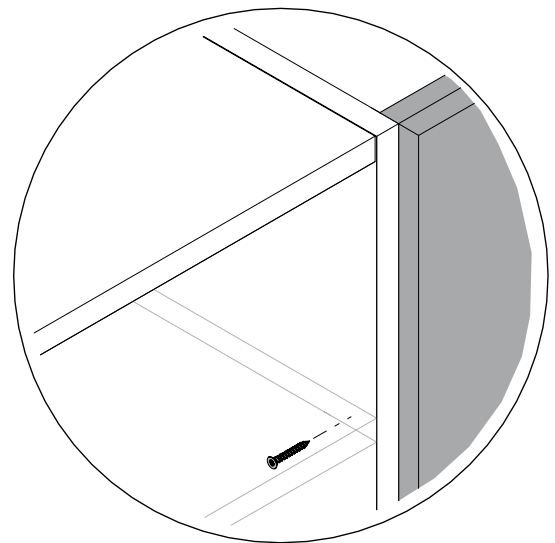
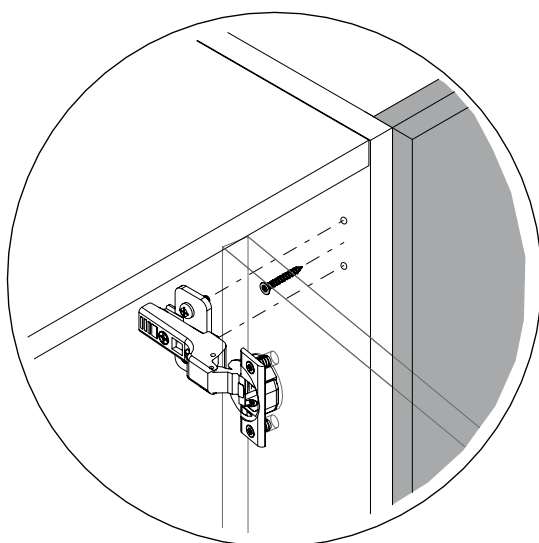

# C SOCLE / PLINTH

## QUINCAILLERIE / HARDWARE

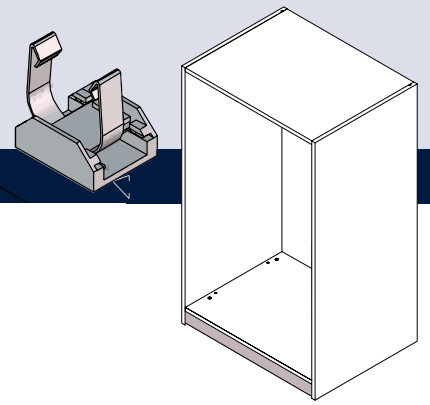

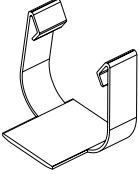
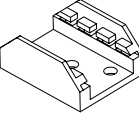
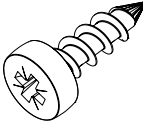
P31018300	P31019200	P29455300
		
A	B	Ø3,5x12 C

1

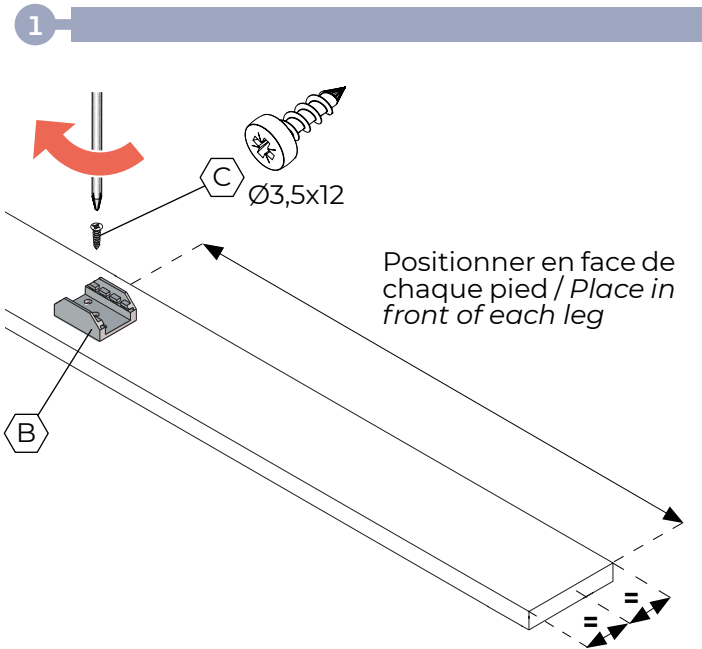

2

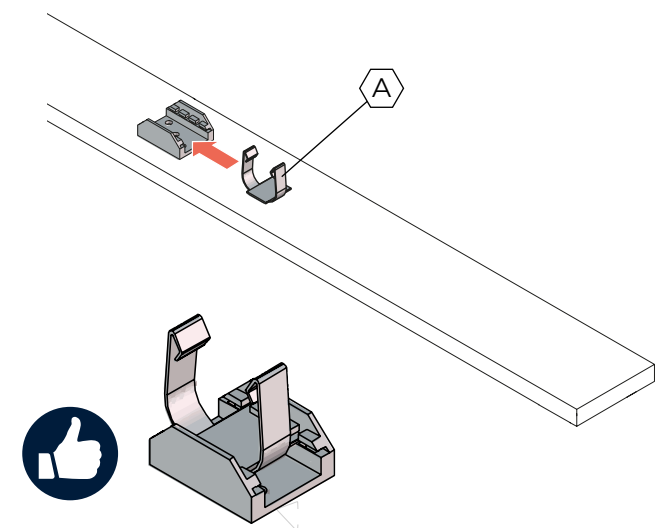

2

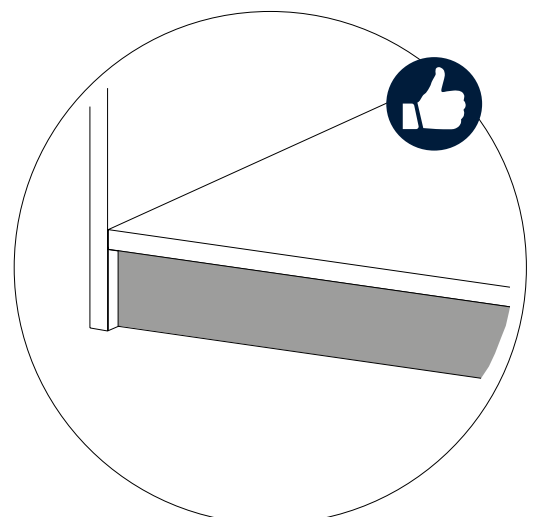
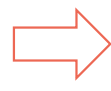
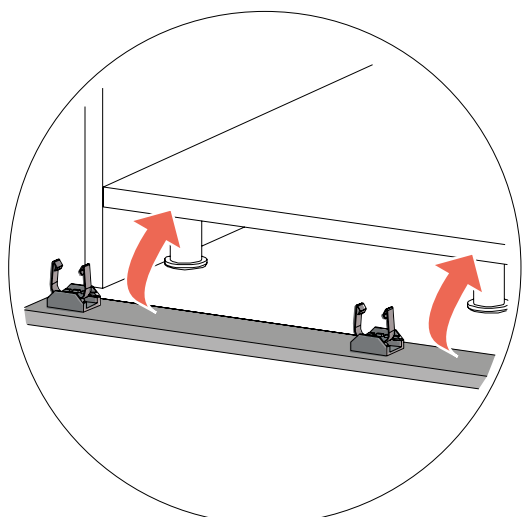

# D PANNEAU DÉCO MIROIR / DECORATIVE MIRROR PANEL

QUINCAILLERIE / HARDWARE



10 min

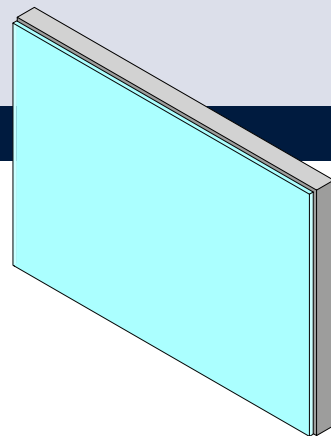
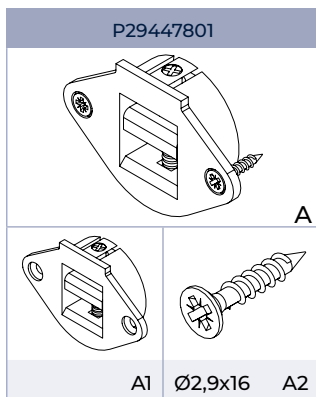

## 1 Perçages du dos / Drilling on the back part

**!** Ne pas traverser la façade / Do not drill all the way through

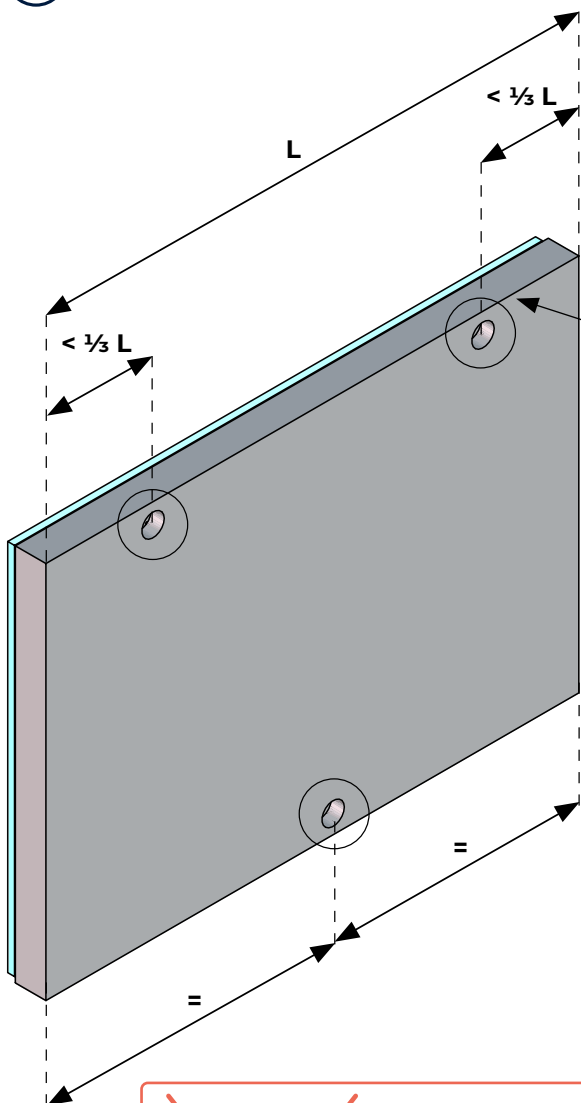

### 1 Pré-perçage / Pre-drilling

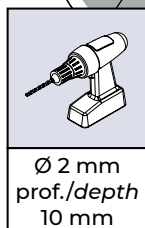
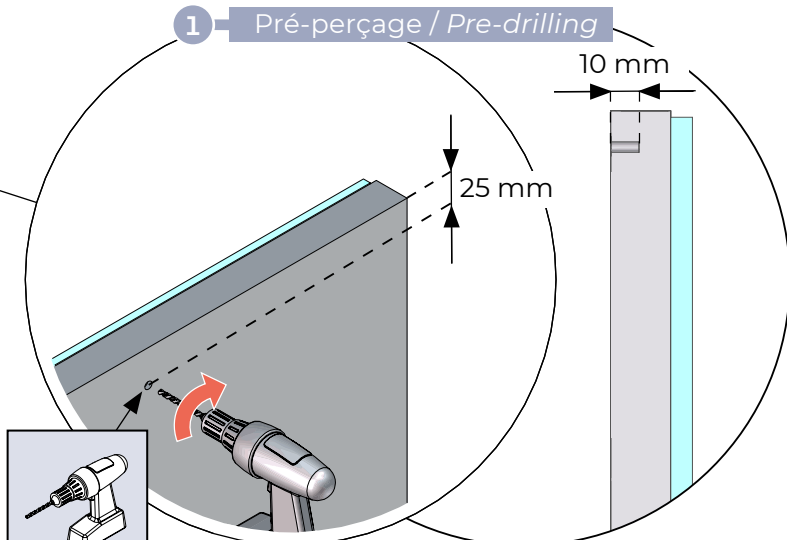

Ø 2 mm  
prof./depth  
10 mm

### 2 Perçage / Drilling

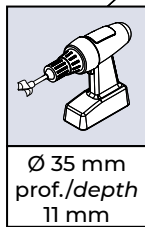
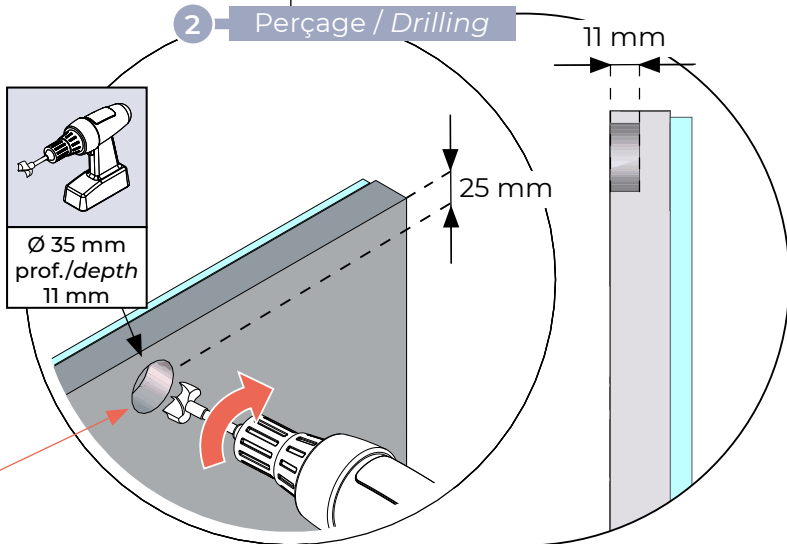

Ø 35 mm  
prof./depth  
11 mm

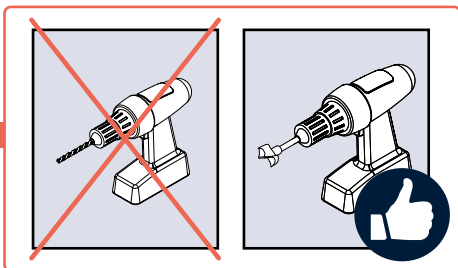

## 2 Perçages des chants / Drilling on edges

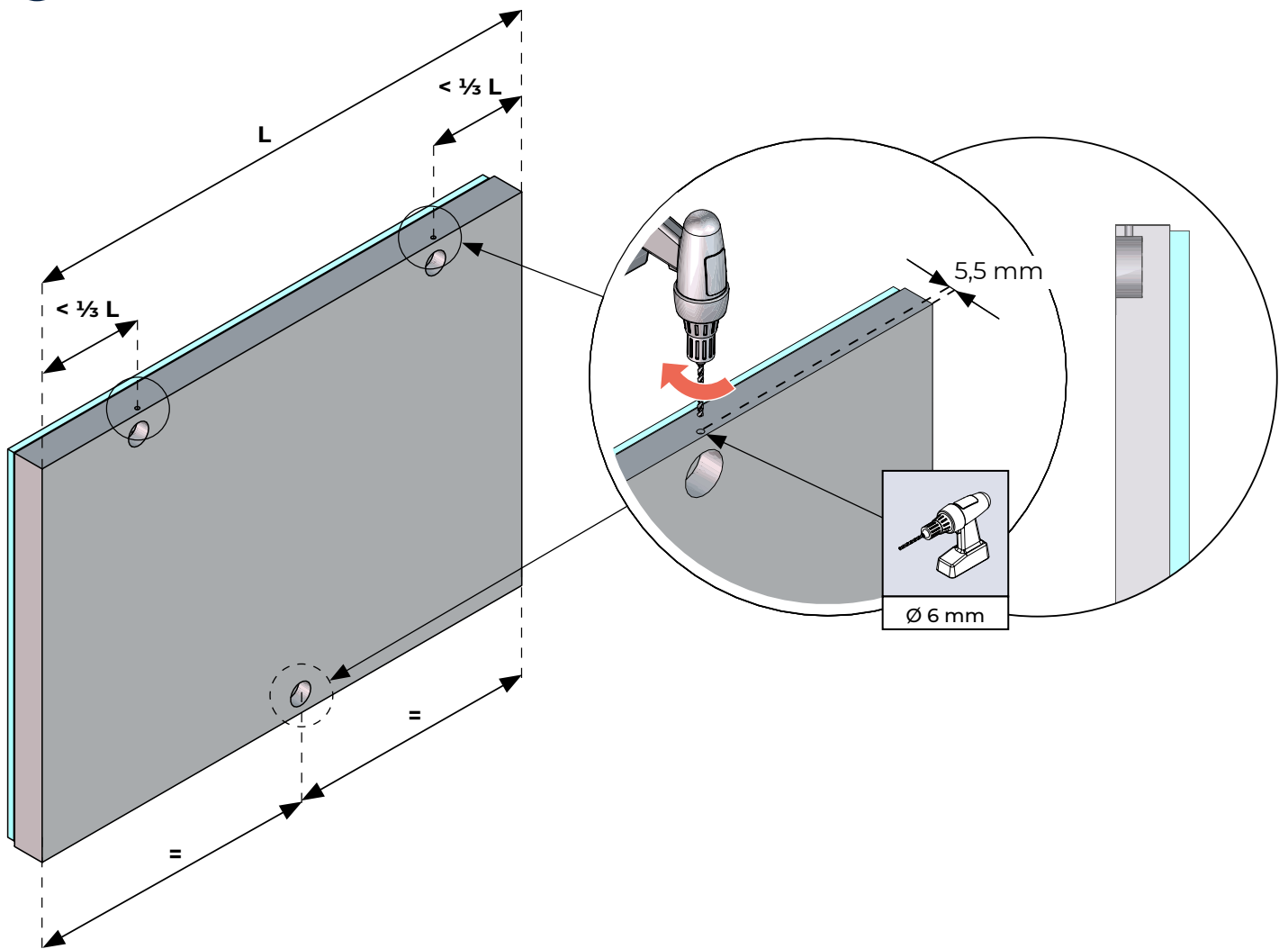

## 3

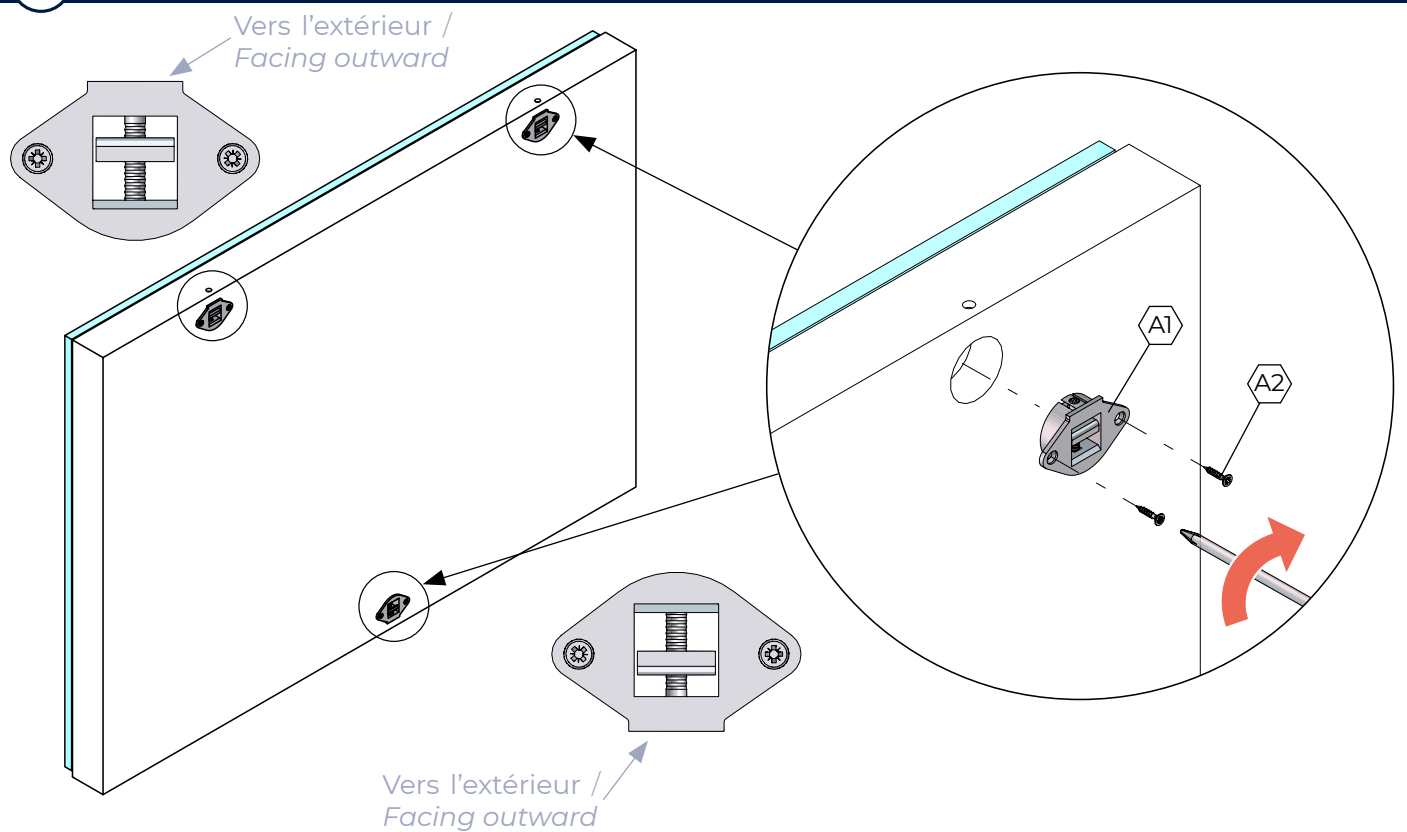

4

  
Si besoin / If needed

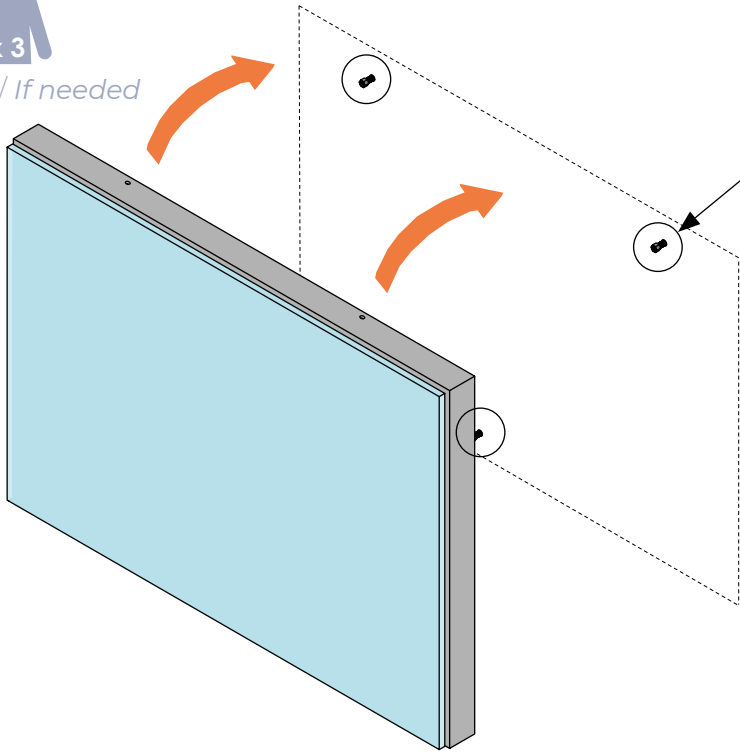

Système de fixation non fourni, à adapter en fonction du support /  
Fixation screws not supplied, to adapt depending on the support

5 Serrage et réglages / Tightening and adjustments

1

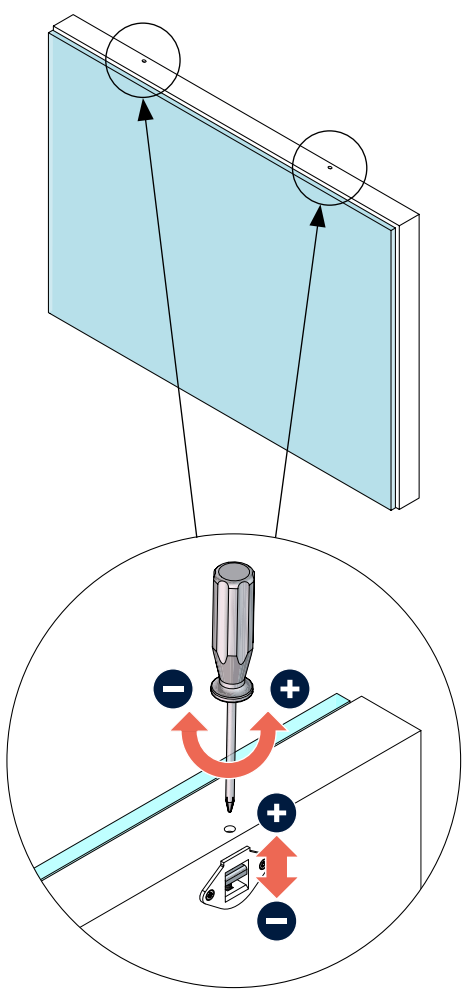

2

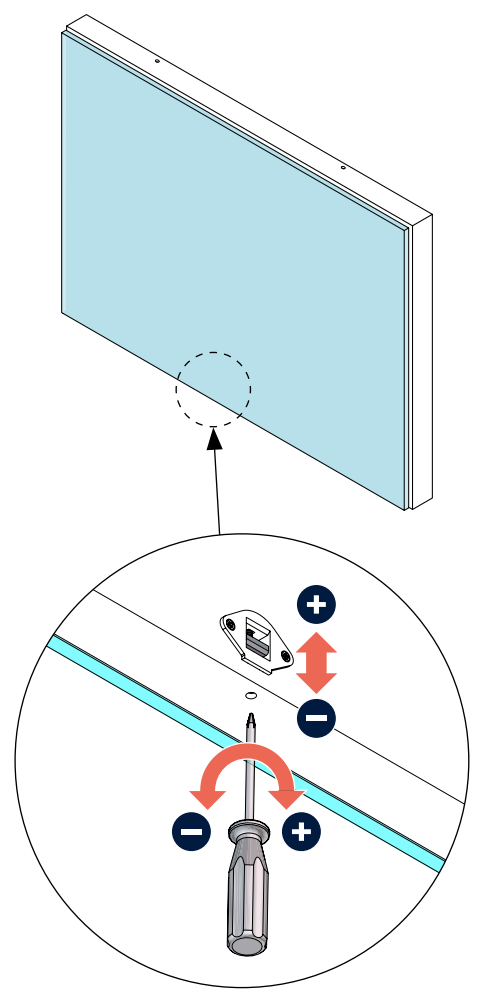

# E PERÇAGES POUR POIGNÉES SUR CHANTS / DRILLINGS FOR HANDLES ON UNIT'S EDGES

## 1 Pré-perçages / Pre-drillings



5 min

1

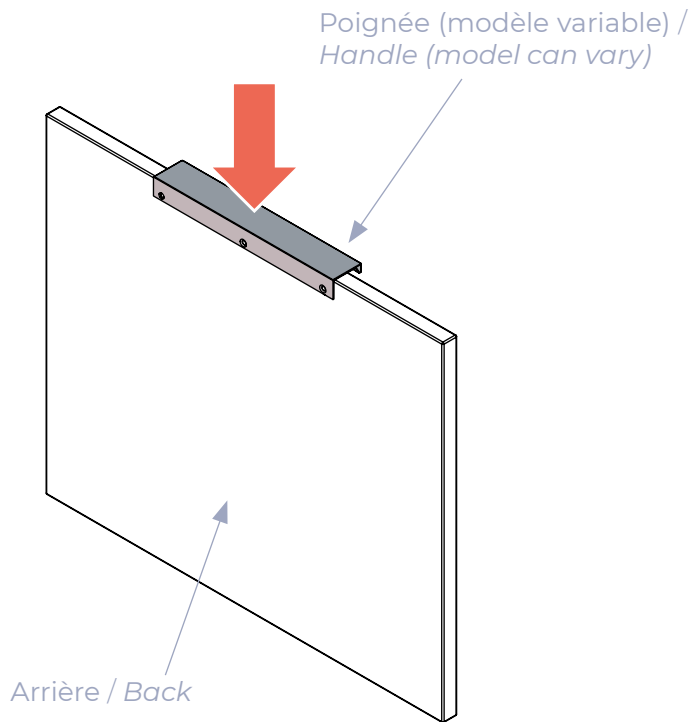

## 2 Pré-perçage / Pre-drilling

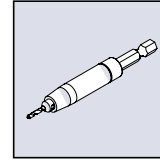

Mèche à centrer préconisée /  
Self centering drills recommended

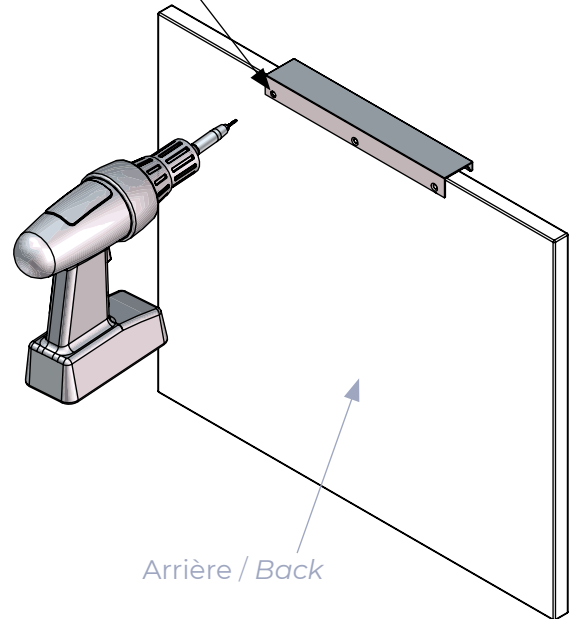

2

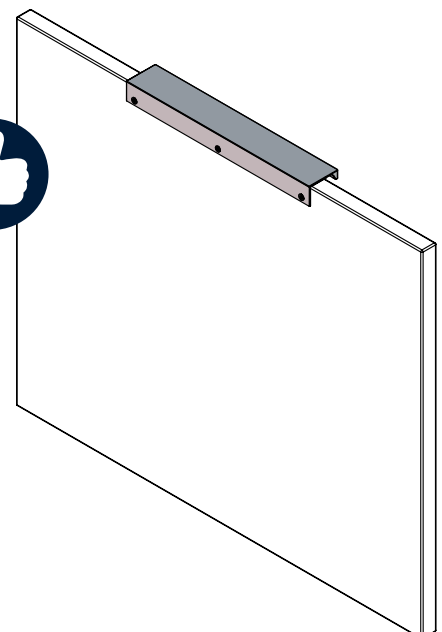
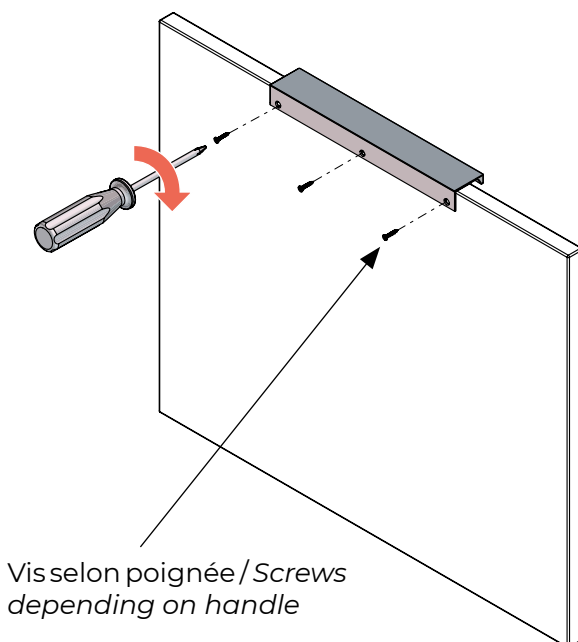

# F TOUCHE-LÂCHE MANUEL POUR FAÇADES / MANUAL PUSH BUTTON FOR FACADES

QUINCAILLERIE / HARDWARE

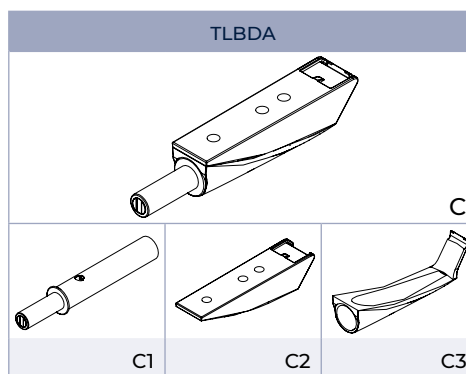
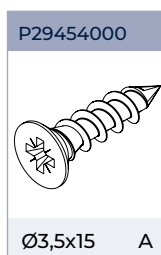
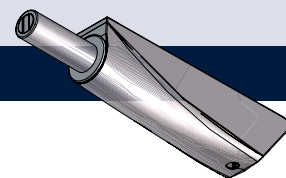

## i Montage standard / Standard assembly

**i** A positionner sur les côtés, le fond ou le plafond du meuble /  
To position on sides, top or bottom of the unit

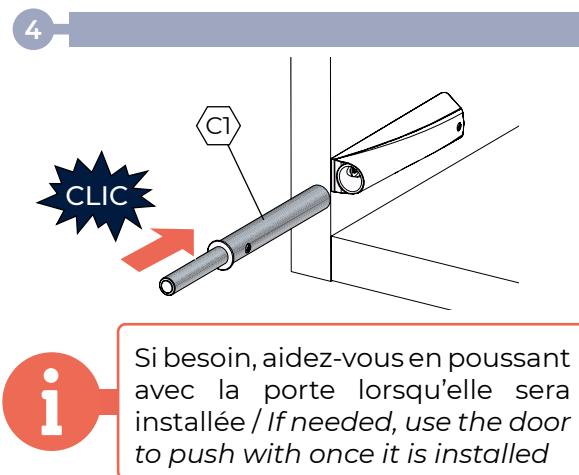
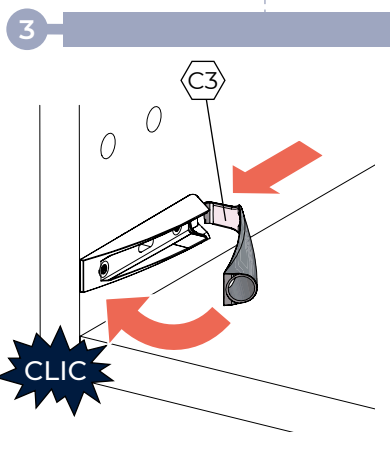
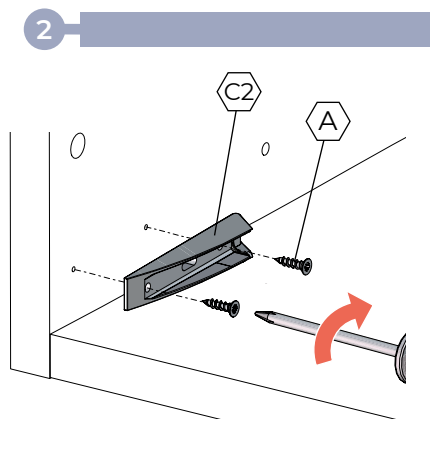
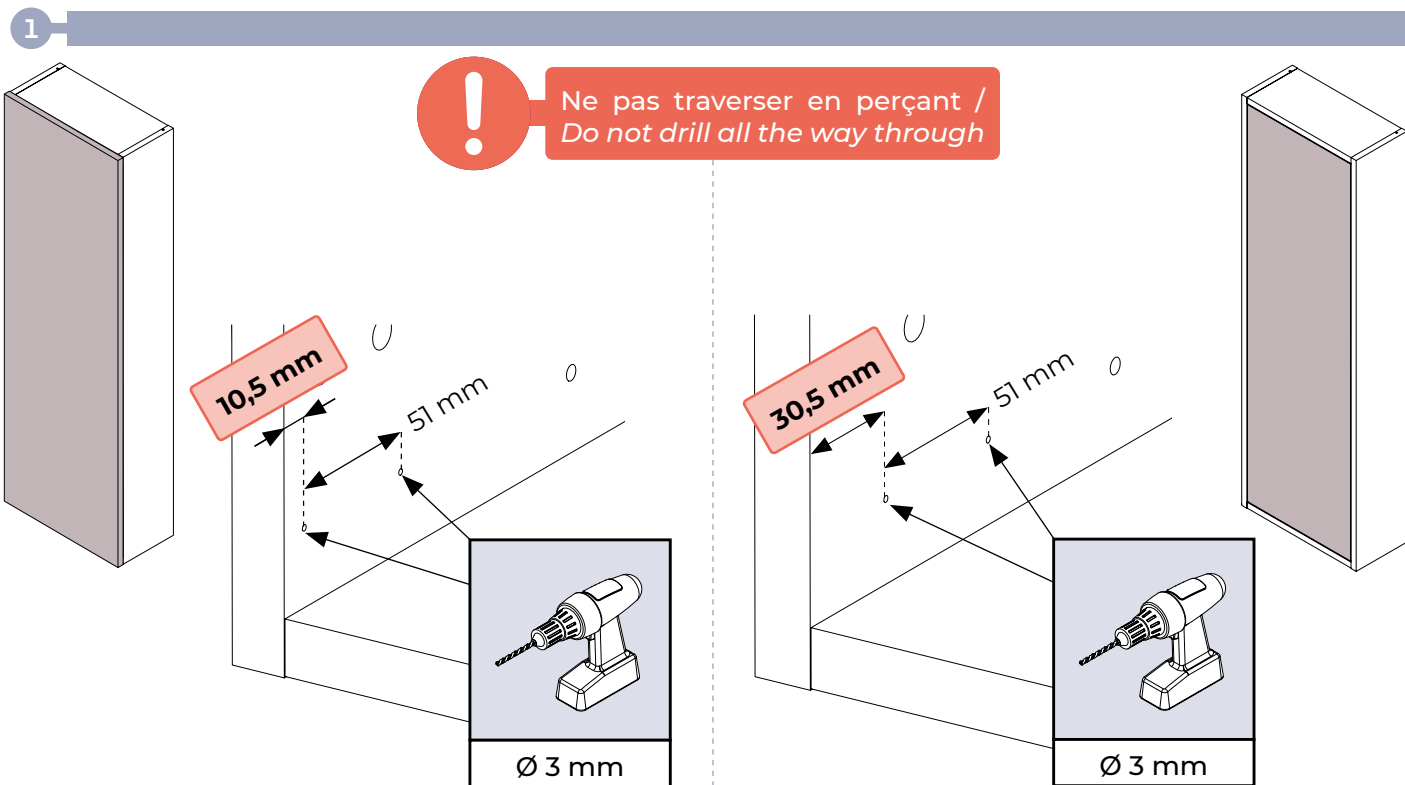



Montage à deux portes / Assembly with 2 doors

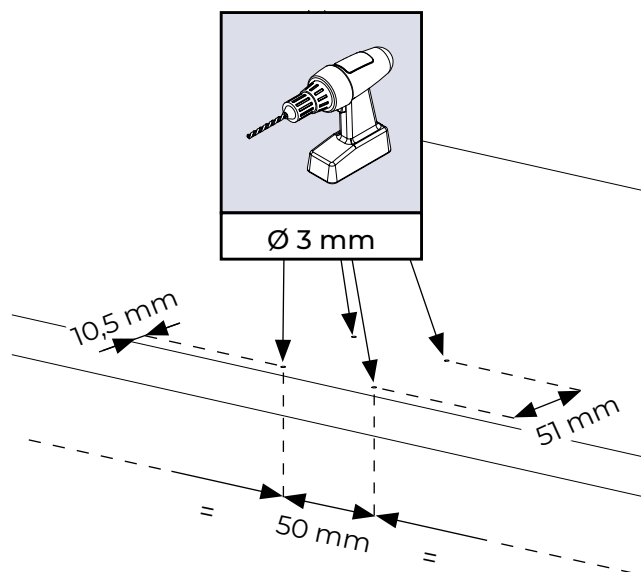

Montage standard / Standard assembly

2 3 4



Réglage / Adjustment

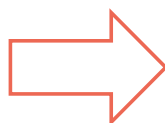
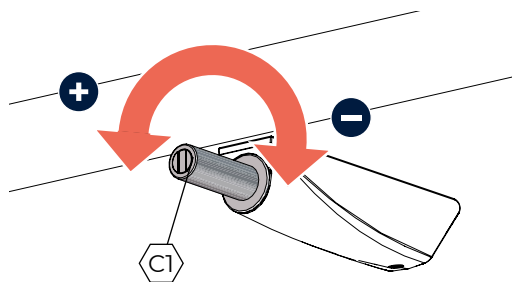

## Fournier SAS

18 Rue des Vernaies, 74230 Thônes  
serviceclients@fourniergroupe.com



**ATTENTION !** : les colonnes doivent être fixées à un mur ou à des meubles adjacents. /  
**CAUTION!**: columns must be fastened to a wall or to nearby pieces of furniture.

NOT\_0000593\_03

Mise à jour : / Update: Juin / June 2025