

Lifting your productivity

EDK350 K30-55-70 1200

EASY-LIFT with pneumatic turning and tilting

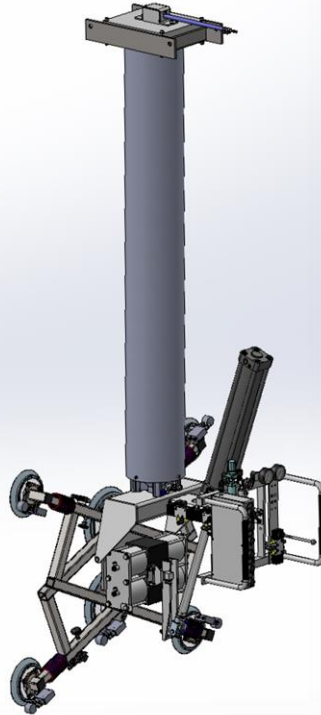

Key features:

- Delivered with an integrated crane trolley for easy installation on light weight craneway systems and pillar slewing cranes with a double-rail jib
- Quick and safe transportation of glass and other plates with rigid handling equipment guidance
- Accurate positioning with stepless, adjustable lifting speed

Safety:

- Vacuum system uses Venturi nozzles with non-return/self-holding valves and manometers on each suction cup.
- Meets EN 13155 requirements for power failures. In case of power failure, the vacuum lifter can hold the load for 5 minutes, ensuring safe placement of the load

Benefits:

- Purely pneumatic device – no electricity needed.
- Ergonomically arranged control elements
- Adjustable suction pads
- Low own weight
- Minimal maintenance requirements



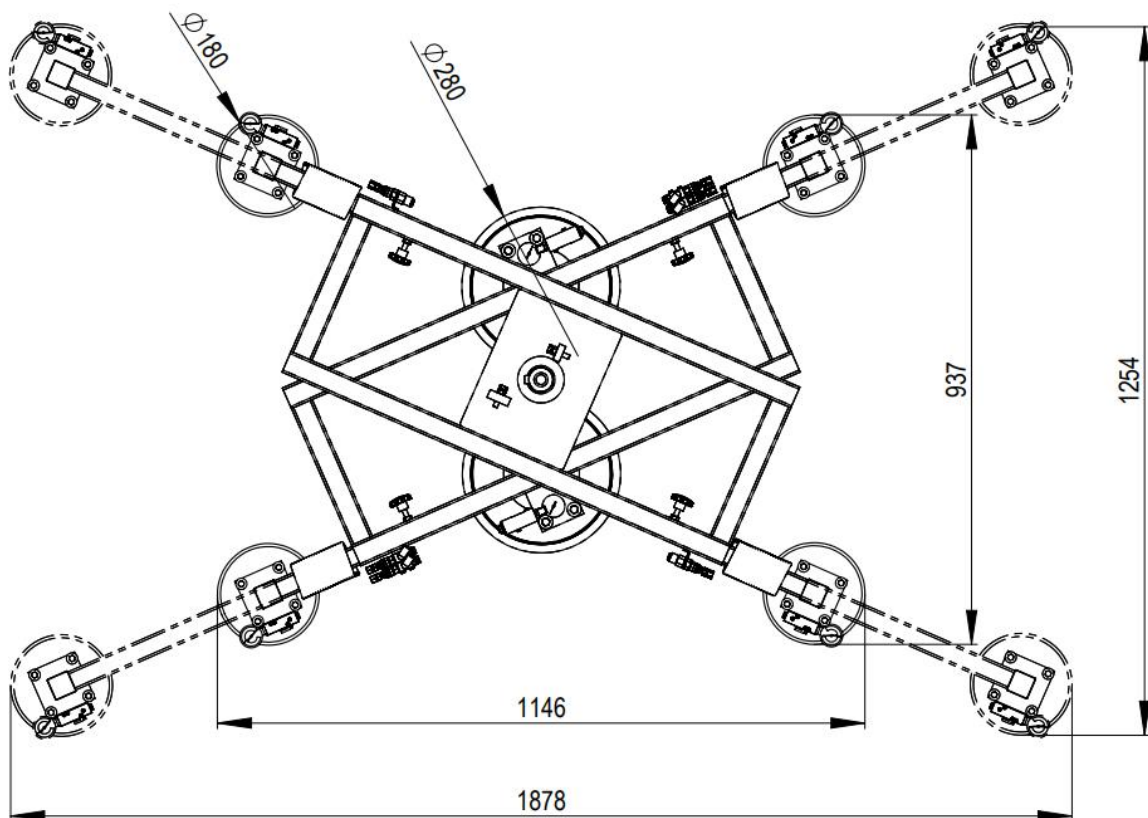

Technical data

Lifting capacity	350 kg
Stroke	1200 mm
Suction frame rotation	0-90°
Suction frame tilting	0-90°
Suction frame	A-622603
Vacuum generation	Venturi nozzles
Feed air supply	6,5 bar, 3/4"
Feed air connection	air hose inner diam. 9 mm
Air consumption (NL/min)	200 NL/min
Suspension height	4000 mm

Available options:

- Service desk adjustable in height/length
- Vacuum display into service desk
- Modification of suction frame
- Automatic power save function
- Support feet for IGUs
- Special suction frame for window manufacturing
- Control integration of friction wheel drive system
- Special colors
- Cylinder stroke change
- Suction frame rotation 180°

