



Bluetooth V5.0 BLE RS-232 Serial Adapter

Model: S2B5232E (External Antenna)

1. Package content:

| | |
|--|---|
| <p>BLE V5.0 RS-232 adapter</p>  <p>White Box: 11 x 6 x 5 (cm) Total Package Weight: 105 g</p>  | <p>Package Contents:</p> <ul style="list-style-type: none"> ● BLE V5.0 RS-232 adapter x 1 ● A4 User manual x 1 ● Mini USB Cable x 1  |
|--|---|

2. Profile:

2.1 Top view:

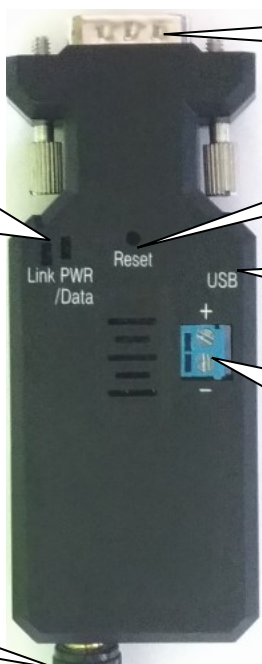

DB9 (Male)

LED:
Link: Blue
PWR/Data: Red

Reset to Default

Mini USB (Power)

▲ + (5~40 VDC)
▼ GND

2 dBi Antenna

| LED Status | Description |
|--------------------------|----------------------|
| Data LED flash | Data transmission |
| Data LED solid on | No data transmission |
| Link LED solid on | BLE Link |
| Link LED flash | No Link |
| Data & Link LED solid on | DFU/OTA Mode |

2.2 Rear Side:

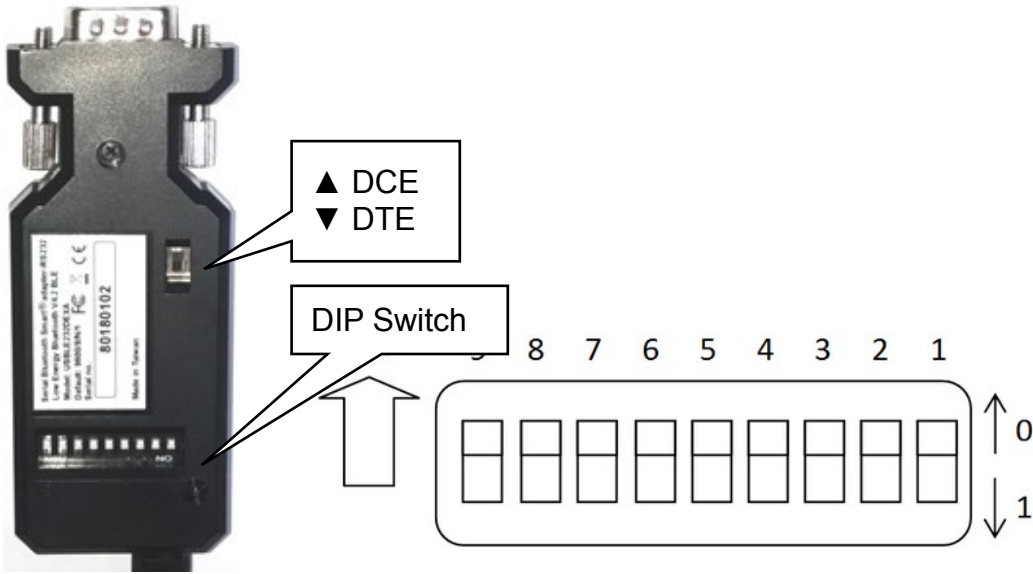

Switch configuration:

| Setup | CTS/RTS | Unused | Parity | Role | Baud Rate |
|---|--------------------------------|--------|---------------------------|---|--|
| 9 | 8 | 7-6 | 5 | 4 | 3-2-1 |
| 0: by APP or Command 1: by Switch | 0: Disable 1: Enable | | 0: None 1: Even | 0: Peripheral 1: Central (Auto link with peripheral) | 110:2400 111:4800 000:9600 001:19200 010:38400 011:57600 100:115200 101:230400 |

Remark:

1. "00000000" by default, in **red bold** character
2. The GATT service and AT command will support more settings than the DIP switch, please check the page 4 section 5 and page 5 section 6.

2.3 DB9 connector (Male)



2: RX 7: RTS
3: TX 8: CTS
5: GND 9: VCC

| Pin | Signal | DTE Direction | DCE Direction | Description |
|-----|--------|---------------|---------------|---------------------------|
| 1 | N/A | | | |
| 2 | RxD | Output | Input | Transmitted data |
| 3 | TxD | Input | Output | Received data |
| 4 | N/A | | | |
| 5 | GND | | | Ground |
| 6 | N/A | | | |
| 7 | RTS | Input | Output | Clear to send |
| 8 | CTS | Output | Input | Request to send (Default) |
| 9 | VCC | | | Power Input (5~40 VDC) |

3. Power supply:

3.1 Voltage: 5~40 VDC, **Don't exceed the limit.**

3.2 There're 3 ways to power the adapter: Mini USB, 2P Terminal Block (Blue) and pin9 of DB9, please choose one. **Don't power the adapter by more than one source.**

3.3 The mini USB to type A cable is inside the standard package.

4. Specifications:

4.1 Default value:

- Baud rate: 9,600 bps
- Data bit: 8
- Parity: none
- Stop bit: 1
- Flow control: none
- Device Name: BLE232
- Pin code: None, Fast pairing

4.2 Serial Port:

- Baud Rate: 1.2/2.4/4.8/9.6/19.2/38.4/57.6/115.2/230.4 Kbps
- Parity: none/even, w/o Odd
- Stop bit: 1 (Only)
- Data bit: 8 (Only)

Remark: The GATT service and AT command will support all the functions, please check the page 4 section 5 and page 5 section 6.

4.3 Range: max. 50 m in open space (The range depends on the real environment.)

4.4 TX Power: Max. 4 dBm

4.5 RX Sensitivity: -96 dBm typical

4.6 TX current consumption of 16.6 mA (radio only, 4 dbm)

4.7 Operation Temperature: -40 °C to +85 °C

4.8 Dimensions: 87 mm (L) x 34 mm (W) x 18 mm (H)

4.9 Antenna Gain: max. 2 dB (Default)

Remark: All contents are subject to change without notice.

5. GATT Service:

5.1 Architecture:

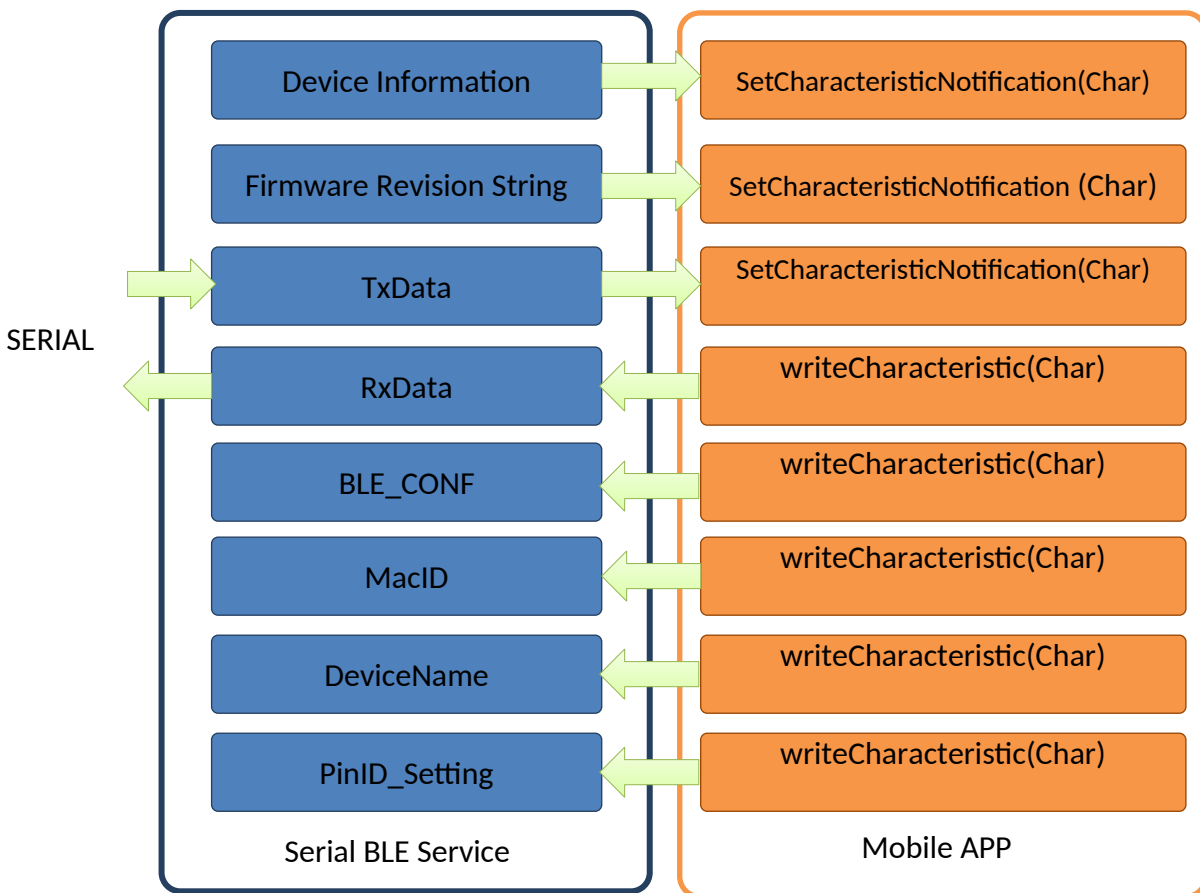

5.2 UUID_1800_SERV = ("00001800-0000-1000-8000-00805F9B34FB")

- UUID = 2A00, Device name, Default: BLE232

5.3 UUID_180A_SERV = ("0000180A-0000-1000-8000-00805F9B34FB")

- UUID= 2A26, Firmware version, Format: x.x.x, ASCII/read only
- UUID= 2A24, BLE version, Format: x.x, ASCII/read only, Value: 4.2 or 5.0

5.4 UUID_BLE_SERV = ("0003ABCD-0000-1000-8000-00805F9B0131") (Self defined UUID)

- **UUID_BLE5DATA** = ("00031201-0000-1000-8000-00805f9b0130"), Data from BLE232_TxData (Notification)
- **UUID_BLE5SENT** = ("00031202-0000-1000-8000-00805f9b0130"),//Data to BLE232_RxData max244bytes/package(write only)
- **UUID_BLE5CONF** = ("00031203-0000-1000-8000-00805f9b0130"), Configuration, 4bytes, (read/write)

UUID_BLE_Config (4 bytes): 00031203-0000-1000-8000-00805F9B0130

| Byte0 (Read Only) | Byte1 | Byte2 | Byte3 |
|-------------------|------------------|-------|--|
| Product model | Baud Rate | N/A | Port setting |
| 0xAA: RS232 | 0x00: 1200 bps | | bit 0: Parity (0: NONE 1: EVEN) |
| 0xAF: RS485/422 | 0x01: 2400 bps | | bit 1: Flow control (0: Disabled 1: Enabled) (for RS232 model Only) |
| | 0x02: 4800 bps | | bit 2: N/A |
| | 0x03: 9600 bps | | bit 3: Port Type (0: RS485 1: RS422) (Available on RS485 model only) |
| | 0x04: 19200 bps | | bit 4: BLE Role (0: Peripheral 1: Central) (indication Only) |
| | 0x05: 38400 bps | | bit 5: ControlSet (0: set by APP or command 1: set by 9P switch) (indication Only) |
| | 0x06: 57600 bps | | |
| | 0x07: 115200 bps | | |
| | 0x08: 230400 bps | | |

- **UUID_BLE5ADDR** = ("00031204-0000-1000-8000-00805f9b0130"), Target Peripheral Mac. Address, 6bytes,(read/write)
- **UUID_BLE5NAME** = ("00031205-0000-1000-8000-00805f9b0130"), Device name, Max. 15bytes, UTF-8,(read/write)
- **UUID_BLE5PIN** = ("00031206-0000-1000-8000-00805f9b0130"), Pin code, 6bytes, (read/write)
- **UUID_BLE5RBT** = ("00031210-0000-1000-8000-00805f9b0130");Reboot, 2bytes, (read/write)

6. Command set via COM port:

| Command | Value | Description |
|---------|-------|---|
| AT | | Check the connection status between control terminal and the RS-232 adapter. Response: "OK" when the connection is ok. Response: "ERROR" when the connection is not ok. |
| BAUD= | | This command is used to specify the baud rate of COM port. The command will need 200 ms delay. |
| | 1200 | 1200 bps |
| | 2400 | 2400 bps |
| | 4800 | 4800 bps |
| | 9600 | 9600 bps |

| | | |
|-----------|----------|--|
| (Default) | 19200 | 19200 bps |
| | 38400 | 38400 bps |
| | 57600 | 57600 bps |
| | 115200 | 115200 bps |
| | 230400 | 230400 bps |
| | ? | Inquire the current baud rate. |
| DEFAULT= | | This command will restore the default settings. |
| | Y | Restore the default settings (e.g. 19200 bps). The command will re-start the system for 1 second. |
| DFU= | | Device Firmware Upgrade via PC software. OTA (Over the air) is available to upgrade the firmware by APP |
| | Y | |
| ECHO= | | This command is used to specify whether the adaptor echoes characters received from the UART back to the DTE/DCE. |
| | N | Command characters received from the UART are not echoed back to the DTE/DCE. |
| (Default) | Y | Command characters received from the UART are echoed back to the DTE/DCE. |
| | ? | Inquire the current setting. |
| FLOW= | | This command enable or disable flow control signals (CTS/RTS) of the UART port. Note, the setting is not affected by DEFAULT. The command will need 1 second delay. |
| (Default) | N | Disable flow control. |
| | Y | Enable flow control. |
| | ? | Inquire the current setting |
| NAME= | | This command is used to specify a device name for the adaptor. You can specify a friendly name using 0 to 9, A to Z, a to z, space and -, which are all valid characters. Note that "first space or -, last space or - isn't permitted". The default name is "Serial Adaptor". |
| (Default) | BLE232 | Default device name |
| | xx....xx | "xx....xx" is a character string with the length from 2 to 30. |
| | R | Restore the default settings name="BLE Serial". |
| | ? | Inquire the name of the local adaptor. |
| PARITY= | | This command is used to specify parity bit setting of COM port. The command will need 200 ms delay. |
| (Default) | N | None parity bit |
| | E | Even parity |
| | ? | Inquire the current setting. |
| PIN= | | This command is used to specify a PIN code. The default is simple pairing w/o PIN code. The format is 6 number only. |
| | 000000 | Disable the PIN authentication and fast pairing |
| | xx....xx | "xx....xx" is a 0~9 number |
| | ? | Inquire the current PIN. |
| PROMPT= | | The command is used to decide whether result messages are prompted when Setup commands are executed. The result messages are: OK/ERROR for command execution. |

| | | |
|-----------|---|--|
| (Default) | Y | Prompt result messages. |
| | N | Not prompt result messages. |
| | ? | Inquire the current setting. |
| ROLE= | | This command is used to specify whether the adaptor is in the central or peripheral role. If the device role is changed, the adaptor will reboot and all paired addresses will be cleared. |
| | C | Set the adaptor to the central role. |
| (Default) | P | Set the adaptor to the peripheral role. |
| | ? | Inquire the current role of the adaptor. |
| STATUS= | | Inquire all the current setting of the adapter. |
| | ? | Display the current setting of the adapter |
| VERSION= | | This command is used to inquiry the firmware version. |
| | ? | Inquire the version codes. |

7. Central and Peripheral: (Similar like the traditional Bluetooth Master and Slave roles)

7.1 DIP switch setting: The central will pair the slave automatically, please refer to page 2 section 2.3.

- Switch DIP-9 to 1 (Configuration by DIP Switch)
- Switch DIP-4 to 1 (Central)
- The central will link with the neighboring peripheral automatically. The blue LED will be solid on. The central will link with the paired peripheral on next time when power on.
- Please reset to the default and follow the above procedures if you want to link with other same BLE serial adapter.

7.2 AT command: Please refer to page 5 section 6. The DIP-9 on the default setting (0).

- Set “role=c” or “ROLE=C” in one adapter.
- The central will link with the neighboring peripheral automatically. The blue LED will be solid on. The central will link with the paired peripheral on next time when power on.
- Please reset to the default and follow the above procedures if you want to link with other BLE devices.

7.3 APP setup: Please contact the supplier to for the test APP.

- The APP will search the BLE and select one as the central.
- Then select the other one as the peripheral and link.
- The central will link with the neighboring peripheral automatically. The blue LED will be solid on. The central will link with the paired peripheral on next time when power on.
- Please reset to the default and follow the above procedures if you want to link with other BLE devices.

8. APP: The APP is used for the configuration and the data transmission test.

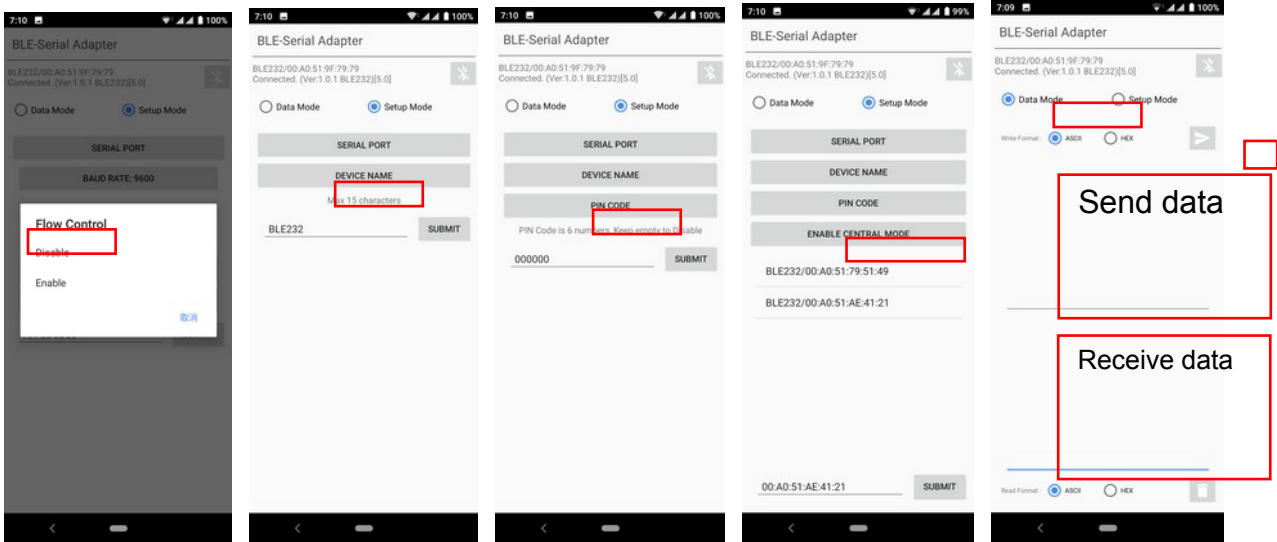
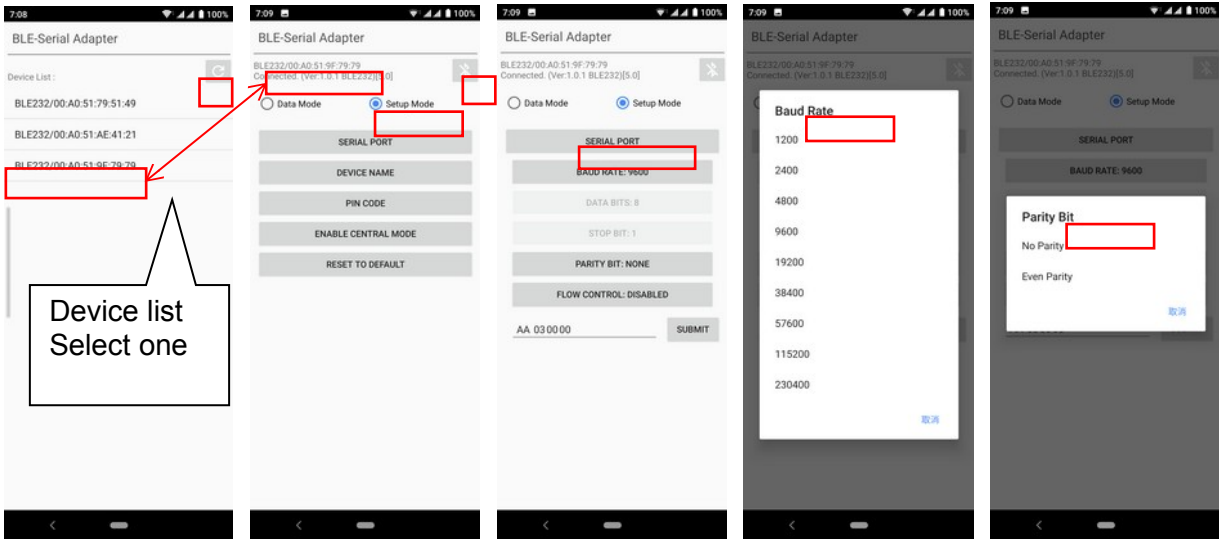

Download: Please contact the supplier for the APP download or the sample code.

Android:

iOS:

