

PIN ASSEMBLY

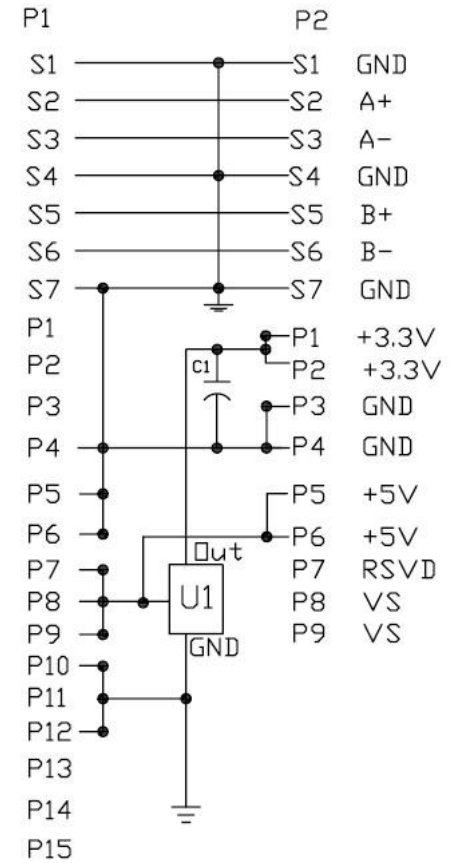

ELECTRONIC TEST:

- 1.OPEN/SHORT/INTERMITTE:100%.
- 2.INSULATION RESISTANCE:5MΩ.
- 3.CONTACT RESISTANCE:10Ω.
- 4.HI-POT:300V 10ms

3	PVC 55P MOLD COLOR: BLACK	PCS	1
2	MICRO SATA 16PIN PCB SIDE	PCS	1
1	SATA 22PIN PCB SIDE	PCS	1
NO.	DESCRIPTION	UNCT	Q'TY

UNLESS OTHERWISE SPECIFIED TOLERANCE			
ANG.	±5°		
0.	±0.5		
.0	±0.3		
.00	±0.2		
SCALE:	1:1	UNIT:	mm
DRAWN	GUOQING	10/03/10	DRAWN NAME:
CHECKED	Xing Fa	10/03/10	竞捷 DN73
APPROVED		10/03/10	PRODUCT NO.
REV.	DESCRIPTION	DATE	FILE NAME: