

REV	DESCRIPTION
▲	

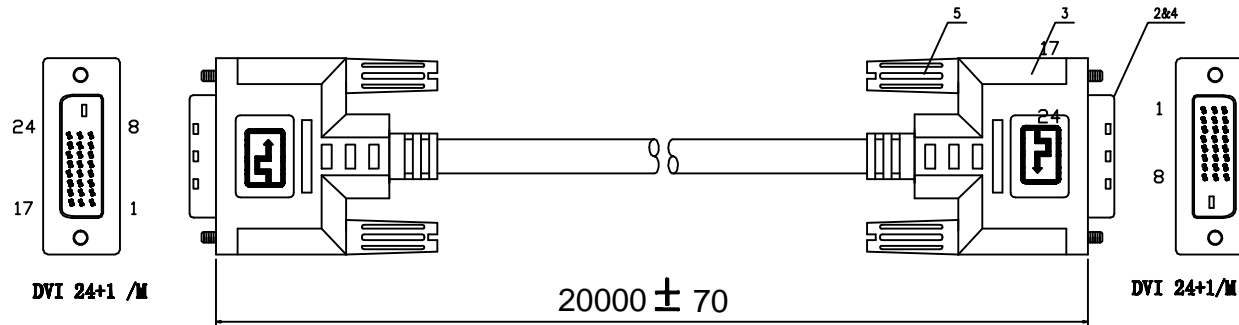

### PIN OUT

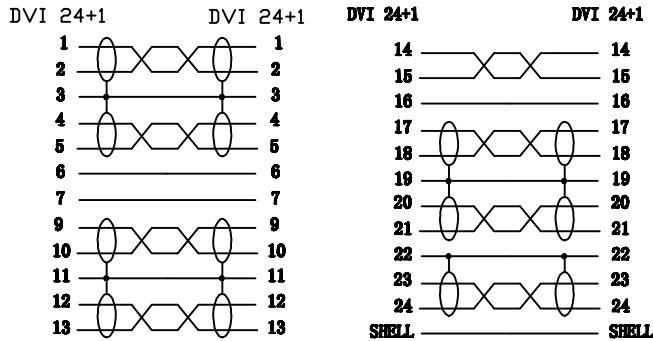

### CABLE STRUCTURE

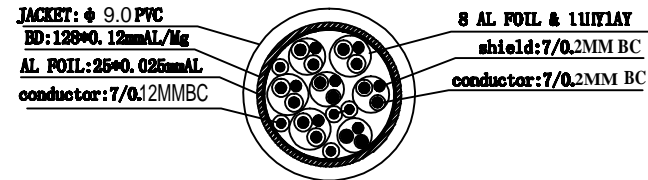

5	2195004	FERRITE	28.5*17.5*9.5	2	BLACK
4	8420001	SCREW	METAL	4	NICKEL
3	8301004	MOLDING	UL 80°C 45P PVC	2	BLACK
2	7225007	CONN.	DVI (24+1) stander connector	2	GOLD
1	6117007	CABLE	(24AWG*IP+Drain+AL+MYLAR)*7P+28AWG*IP+28AWG*5C+AL+BRAIDING+9.0mmPVC	1	BLACK
NO.	PART NO.	PART NAME	MATERIAL	Q' TY	MARKING

		DESCRIPTION	DVI CABLE DVI(24+1)/M - DVI(24+1)/M			
		PRAR NO.	<b>DVI24-XX</b>			
DRAW	July	CONSUMER				
CHECK		DATE	2022.3.15	REV.	A	
APP.		SHEET	1/1	UNIT	mm	SCALE 1:1