

# Projector bracket parts

Parts	Standard package	Extension package
1.Ceiling plate	1X	-
2.Projector plate	1X	-
3.Extension pipes	1X15CM	3X30CM
4.Extension pipes	1X8CM	1X8CM
5.Doble connector	-	3X
6.Projector leg	3X	-
7.Hardware kit	1X	-
8.Rubber gasket	1X	-
9.Manual instructions	1X	-

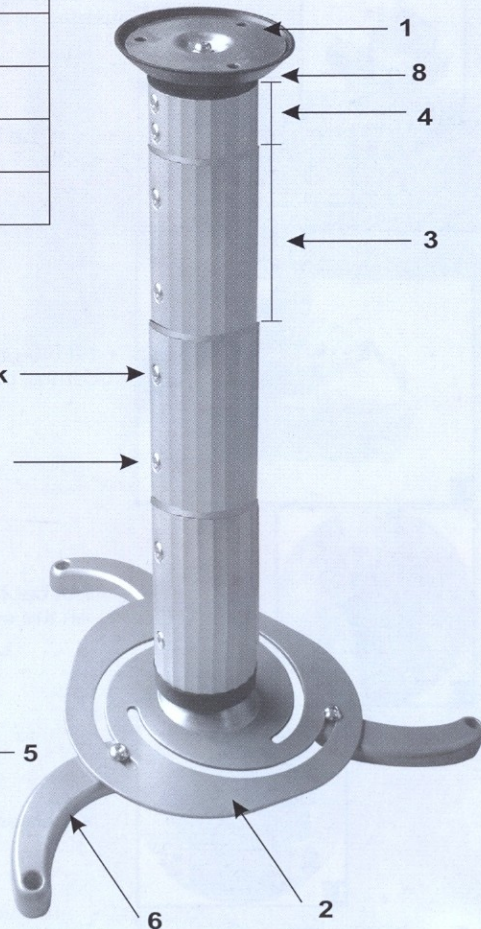

Push to unlock

Turn bolt outside for maximum safety

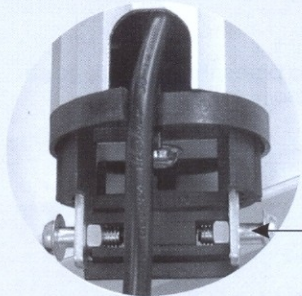

# Manual Instructions

## Universal Ceiling Projector Bracket

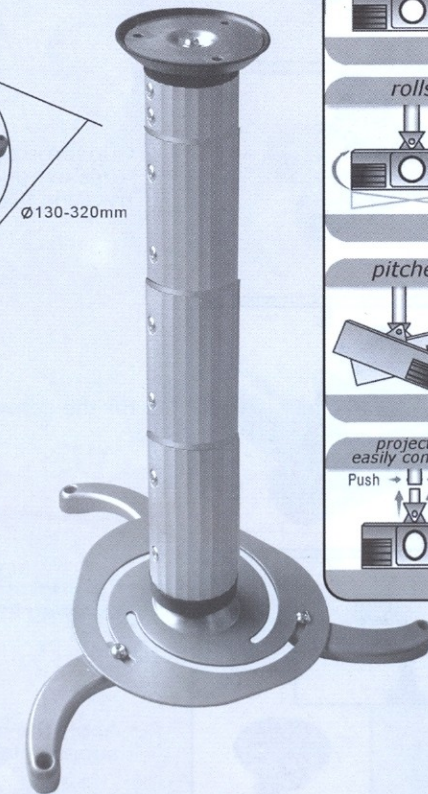
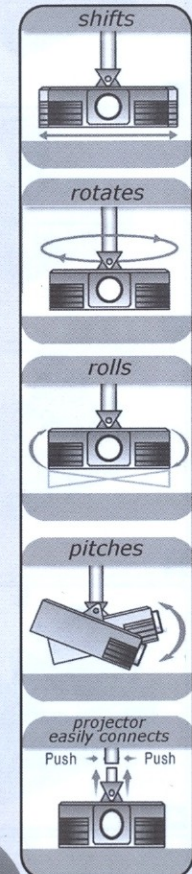
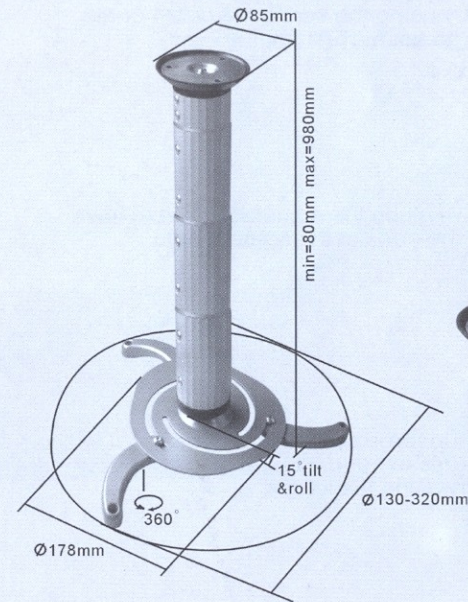



# Assembly Instructions



- Apply the video. Projector to the arms by using the screw M3 or M4 or M5 (do not fix, just apply)

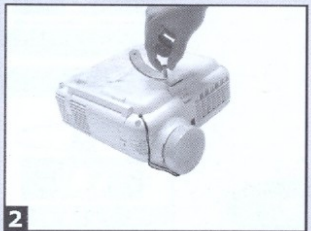

- Work on the adjustable feet to have the arms at the same height



- Converge the arms to centre and fix the arms to bottom holes of the support by using the knobs



- Fix the screws



- Fix the support place to the ceiling, by using the three bottom moles



- Apply the cover ring to the ceiling supportplace

# Assembly Instructions

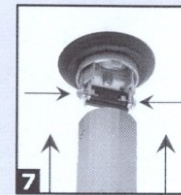

- Join the ceiling supportplate to the extension pipe pushing at the same time the two bolts

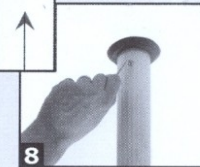

- Turn the bolts outside for the maximum safety

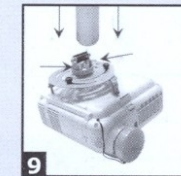

- Join the projector plate to the extension pipe pushing at the same time the two bolts



- Turn the bolts outside for the maximum safety

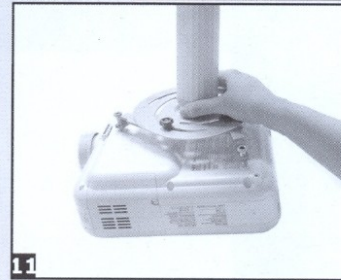

- Tilt the bracket as desired by working on the central part of the assembly swivel



- Put cables into pipes through the gape on the connector

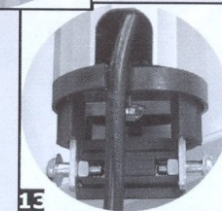

- Cables are hidden in the pipes