

## PRODUCT INFORMATION



**3 Function Medical Bed Central Control Caster Wheel Hollow Rod Clamping Type 32x50mm 125x33x165.3mm**

**REF: QM117**

66 series structure is metal, housing made of high quality engineering ABS. The tread of wheel made of TPE, oil resistance, wearproof and good effect of shock absorbing. The overall fully enclosed design, dustproof, anti-winding. Swivel castor with central, total lock and central directional lock



### Technical Data

Wheel diameter	200mm
Width of Tread	35mm
Tread material	TPE
Central control shaft length	96.8mm
Central control shaft diameter	28mm
tube diameter	68mm
Swivel diameter	160mm
Overall height	235.8mm
Temperature	- 10 / + 40° C
Standard	EN 12531
Weight	1.7kg
Load capacity	110kg
Load capacity (static)	220kg

### Dimensions

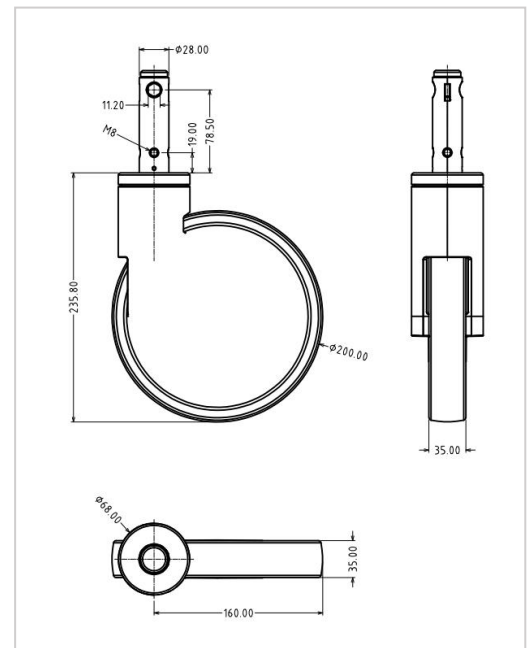

### Structure & Mounting

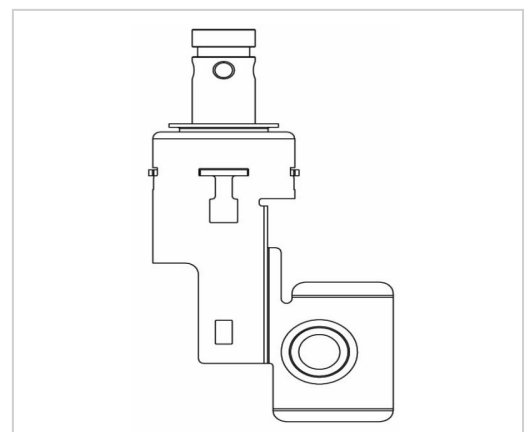

### Advantages at a glance

Roll performance	● ● ● ● ●
Movement noise	● ● ●
Attrition	● ● ● ●
Corrosion resistance	● ● ● ●