



BeagleBone Black Expansion I/O Cape User Guide

BUY ON
www.cablematic.com

Content

Introduction & Features of USB-2COM-BB	2
Introduction of USB-2COM-BB.....	2
Features of USB-2COM-BB.....	2
System Requirements.....	3
Picture of USB-2COM-BB	3
Diagram of USB-2COM-BB	4
Dimension of USB-2COM-BB	4
Specification.....	5
USB port (CN1, CN2) pin-out	6
Serial port (DB9 Male connector) pin-out.....	7
Installation	8

BUY ON
www.cablematic.com

Introduction & Features of USB-2COM-BB

Introduction of USB-2COM-BB

The USB-2COM-BB is a plug-in RS-232 cape designed for the developers and users of BeagleBone and BeagleBone Black. The USB-2COM-BB BeagleBone RS-232 cape provides two high-speed RS-232 serial interfaces, two high-efficient USB 2.0 ports and one Micro SD card reader. The two RS-232 ports are located to the side of the cape with two 90-degree 10-pin connectors. Two IDC flat ribbon cables with D-Sub 9-pin male serial connectors are provided with the cape to connect the two 10-pin serial connectors. The flat ribbon cable provides the convenience for extended connection of serial devices. This dual RS-232 cape is designed to allow any other capes to be stacked above it without interference mechanically. When there is a need to add four serial ports, user can just stack two USB-2COM-BB modules over BeagleBone and BeagleBone Black.

When the USB-2COM-BB plugged to the USB port of BeagleBone or BeagleBone Black, the two serial ports, two USB ports and the Micro SD card reader are automatically detected and installed. The USB-2COM-BB board is designed with GL852G USB2.0 MTT Hub controller to expand the single USB port on BeagleBone Black and BeagleBone to two USB 2.0 ports for USB connection.

The USB-2COM-BB cape is a high-speed dual RS-232 ports/ dual USB ports /Micro SD reader cape that provides to BeagleBone Black and BeagleBone's developers a cost-economical expansion I/O module to add two serial ports, two USB ports and one MicroSD card reader for their development.

Features of USB-2COM-BB

- Fully compatible with BeagleBone Black or BeagleBone platform
- Adds two high speed RS-232 serial ports via USB connection
- Each serial port provided 384 bytes receive buffer and 128 bytes transmit buffer for high speed data throughput
- Each serial port communication data rates up to 1 Mbps.
- Connector: two DB9 Male connectors via IDC flat ribbon cable
- RS-232 data signals: DCD, RxD, TxD, DTR, GND, DSR, RTS, CTS, RI
- Two downstream USB 2.0 ports with over-current detection and protection
- Each downstream USB port supports 5V 500 mA power for external high power USB devices
- Individual port power management
- Supports USB 1.1 and USB 2.0 transfer speeds from 1.5 Mbps to 480 Mbps, automatic link and speed detection
- Plug-and-Play; no software or drivers required
- Supports SD specification v1.0 / v1.1 / v2.0 / SDHC, up to 32GB
- Compatible with SDXC, Up to 2TB
- Micro SD card reader with 480 Mbps USB 2.0 transfer speed
- CE, FCC approval

System Requirements

BeagleBone Black or BeagleBone platform

Picture of USB-2COM-BB

USB-2COM-BB (without Micro SD Card Reader)

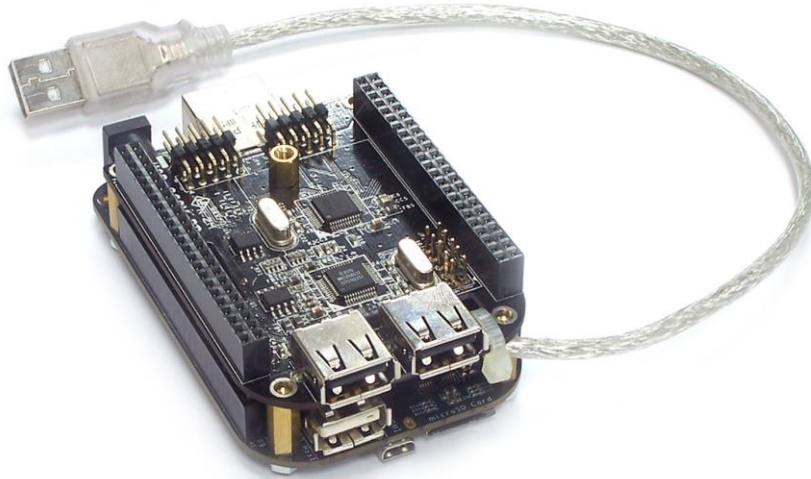

USB-2COM-BB (with Micro SD Card Reader)



Diagram of USB-2COM-BB

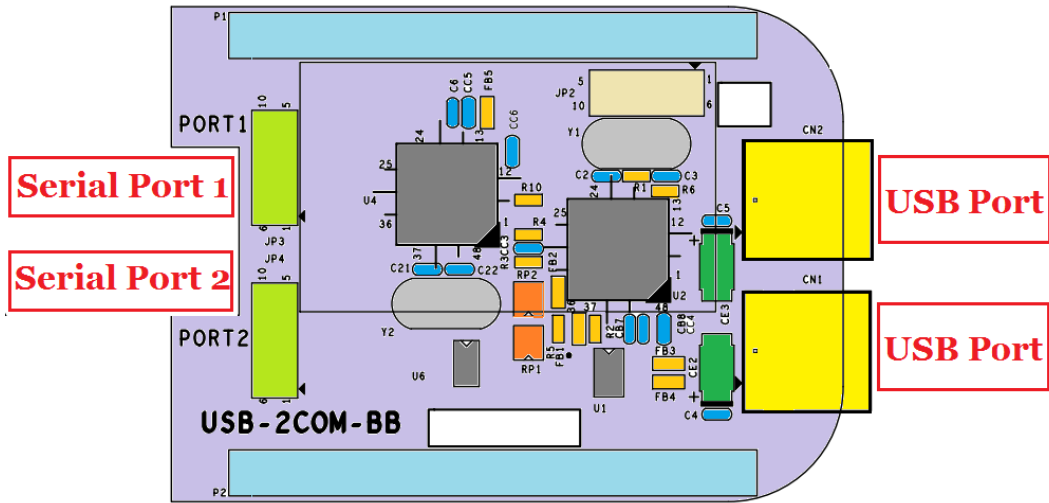

Dimension of USB-2COM-BB

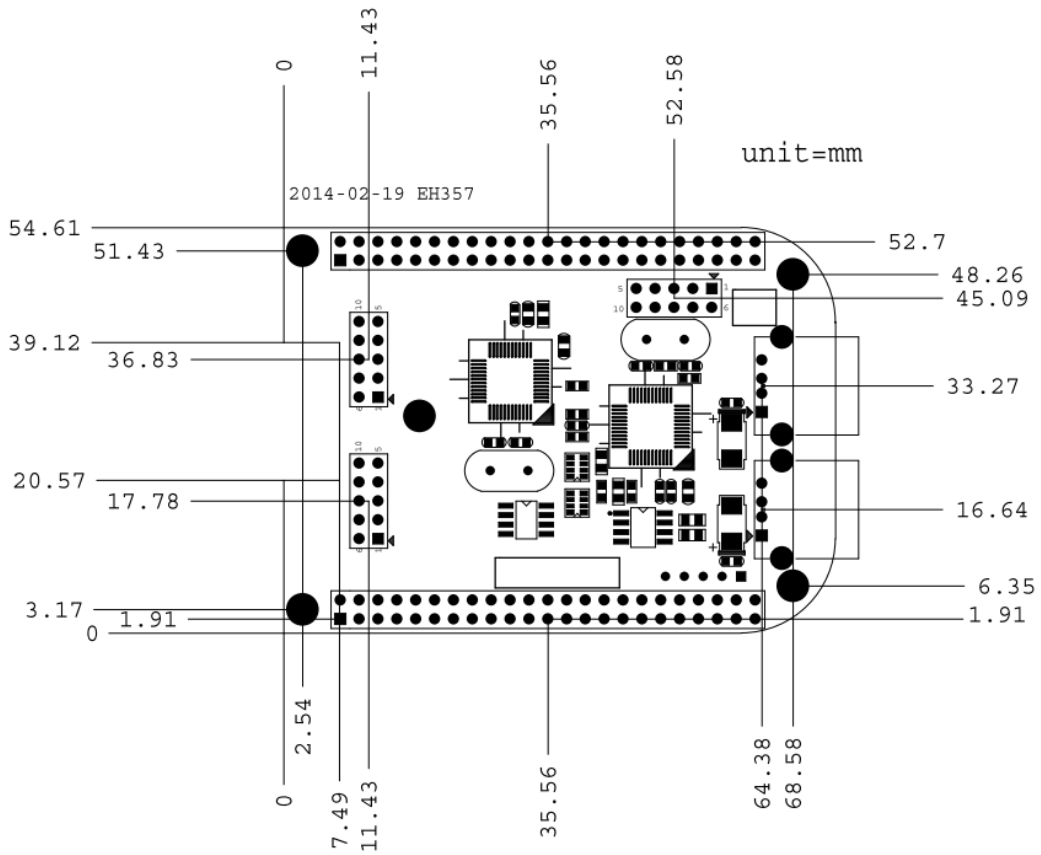

Specification

USB 2.0 Port		
Ports	Downstream	2
	Upstream	1
Power Mode		Self Power Mode
Output Voltage (per port)		+5V DC
Output Current (per port)		500 mA (max)

Micro SD Card Reader	
Speed	480 Mbps USB 2.0 transfer speed
Support Memory Card	Micro SD/ SDHC/ SDXC

Serial Port	
Serial Ports	Two RS-232 ports
RS-232 Signals	DCD, RxD, TxD, DTR, GND, DSR, RTS, CTS , RI
Maximum Bit rates	921,600 bps
Serial Configuration	Data bits : 7,8 Parity : None, Odd, Even, Mark , Space Stop bits : 1, 2
UART FIFO Buffer Size	Each port with 128 Bytes FIFO for transmit and 384 bytes FIFO for receive.

Mechanical	
Housing	Board only
Weight	52 g
Dimensions	80 mm X 55 mm X 20 mm (L x W x H)

Environmental	
Operating Temperature	0 °C to 70°C
Storage Temperature	-40 °C to 85°C
Humidity	0 to 90% RH. Noncondensing
Safety Approvals	CE, FCC

USB port (CN1, CN2) pin-out

Pin Number	Name	Description
Pin1	VBUS	Provides +5Vdc 500 mA (max) output power
Pin2	D-	USB data-
Pin3	D+	USB data+
Pin4	GND	Ground

Serial port (DB9 Male connector) pin-out

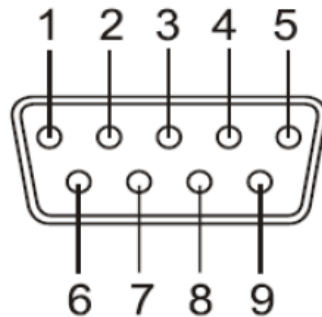

DB9 Male connector pin numbers

Pin Number	Name	Description
Pin1	DCD	Input : Data Carrier Detect
Pin2	RxD	Input : Receive Data
Pin3	TxD	Output : Transmit Data
Pin4	DTR	Output : Data Terminal Ready
Pin5	GND	Ground : Signal Ground
Pin6	DSR	Input : Data Set Ready
Pin7	RTS	Output : Request To Send
Pin8	CTS	Input : Clear To Send
Pin9	RI	Input : Ring Indicator

Installation

The hardware installation of USB-2COM-BB expansion I/O cape is easy to carry out. Follow the detailed steps given below to install the USB-2COM-BB expansion I/O cape in BeagleBone Black or BeagleBone platform.

Step 1: Turn your BeagleBone Black or BeagleBone platform's power off, and also shut off the power to any peripheral devices.

Step 2: Fasten four copper tubes, with four nuts, on the BeagleBone Black or BeagleBone platform.

Step 3: Insert the USB-2COM-BB expansion I/O cape into the BeagleBone Black or BeagleBone platform's interface slot.

Step 4: Fasten the holding screws to fix the USB-2COM-BB expansion I/O module in place.

After installing the USB-2COM-BB expansion I/O cape in BeagleBone Black or BeagleBone platform successfully, please follow the steps below to confirm the Linux driver of USB-2COM-BB is installed automatically.

BeagleBone Black

1. Connect the USB cable of USB-2COM-BB to the A-type USB connector of BeagleBone Black.
2. Insert your Micro SD memory card into the Micro SD reader slot on USB-2COM-BB expansion I/O cape.
3. Connect AC to DC 5V power adapter to BeagleBone Black platform. The blue power LED will light when BeagleBone Black platform is receiving power.
4. After the Angstrom Linux screen boots up, connect the USB mouse and USB keyboard to the two USB ports on the USB-2COM-BB expansion I/O cape. You can use USB mouse to control the cursor under the Angstrom Linux screen.
5. You will find a new disk device under the Angstrom Linux screen when you insert a Micro SD memory card into the Micro SD card reader slot on USB-2COM-BB expansion I/O cape.
6. Open a "Terminal" program, under Applications of the Angstrom Linux screen, to check USB keyboard and the two serial ports. Go there by select "Applications" –"System Tools"- "Terminal".

7. Use a USB keyboard to key-in the command under “Terminal” program to find the available serial ports. Most likely, the Angstrom Linux will support two serial ports of USB-2COM-BB with ttyUSB0 and ttyUSB1:

Key-in the following commands to check the two serial ports

```
# stty -F /dev/ttyUSB0
```

```
# stty -F /dev/ttyUSB1
```

If two serial ports of USB-2COM-BB are available, the response is similar to

```
Speed 9600 baud; line = 0;
```

```
-brkint -imaxbel
```

```
# stty -F /dev/ttyUSB0
speed 9600 baud; line = 0;
-brkint -imaxbel
#
# stty -F /dev/ttyUSB1
speed 9600 baud; line = 0;
-brkint -imaxbel
```

BeagleBone

1. Connect the USB cable of BeagleBone to a computer with Windows O.S. Make sure your computer has Internet connection.

In Windows 8, 7, Server 2008 R2 O.S system, your system will load and install the drivers for BeagleBone automatically.

In Windows Vista, XP, Server 2003 and 2008 O.S system, when asked to install drivers please allow Windows to search the Internet. Wait, and the system will load and install the drivers automatically.

2. You will find a console port “USB Serial Port (COMx)” under Device Manager of the System Properties screen. Go there by Start- Setting-Control Panel- System Properties – Hardware - Device- Device Manager.

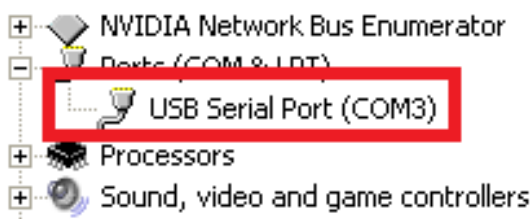

3. Use a “Terminal Emulator” program to open this console port with 115,200 bps baud rate, 8

bits data, none parity, 1 stop bits. After the console port of BeagleBone was open, press “Enter” to find Angstrom Linux screen as below:

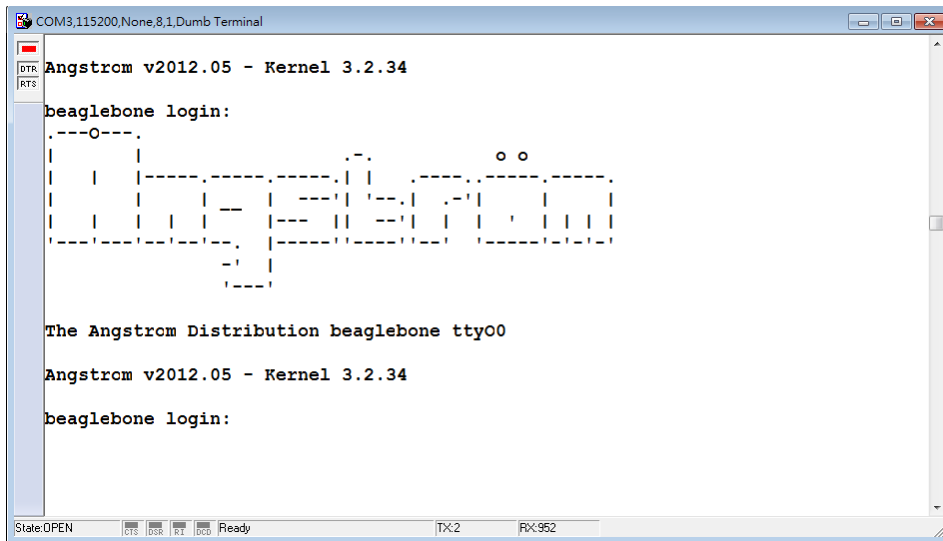

4. After Angstrom Linux screen appears, key-in “root” to enter Angstrom Linux O.S.

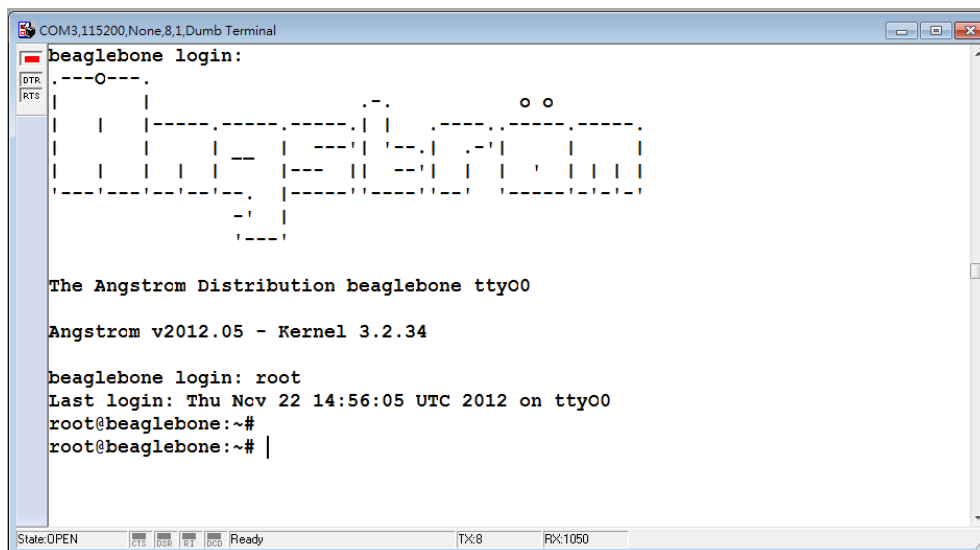

5. Connect the USB mouse and USB keyboard to the two USB ports on the USB-2COM-BB cape, and insert your Micro SD memory card into the Micro SD reader slot.
6. Connect upstream port USB cable of USB-2COM-BB to the A-type USB connector of BeagleBone platform.



7. Key-in “lsusb” under Angstrom Linux O.S, you will find the following message for all USB devices on BeagleBone and USB-2COM-BB:

```
root@beaglebone:~#  
root@beaglebone:~# lsusb  
Bus 001 Device 001: ID 1d6b:0002 Linux Foundation 2.0 root hub  
Bus 001 Device 006: ID 05e3:0610 Genesys Logic, Inc.  
Bus 001 Device 007: ID 05e3:0723 Genesys Logic, Inc.  
Bus 001 Device 008: ID 0403:6010 Future Technology Devices International, Ltd FT  
2232C Dual USB-UART/FIFO IC  
Bus 001 Device 010: ID 413c:2003 Dell Computer Corp. Keyboard  
Bus 001 Device 011: ID 093a:2510 Pixart Imaging, Inc. Hama Optical Mouse  
Bus 002 Device 001: ID 1d6b:0002 Linux Foundation 2.0 root hub  
root@beaglebone:~#  
root@beaglebone:~#
```

Bus 001 Device 001: ID 1d6b:0002 Linux Foundation 2.0 root hub(BeagleBone USB2.0 hub)
Bus 001 Device 006: ID 05e3:0610 Genesys Logic, Inc. (USB-2COM-BB USB2.0 hub chip)
Bus 001 Device 007: ID 05e3:0723 Genesys Logic, Inc. (USB-2COM-BB Micro SD card reader chip)
Bus 001 Device 008: ID 0403:6010 Future Technology Devices International, Ltd FT 2232C Dual
USB-UART/FIFO IC (USB-2COM-BB dual USB UART chip)
Bus 001 Device 010: ID 413c:2003 Dell Computer Corp. Keyboard(USB keyboard on USB-2COM-BB)
Bus 001 Device 011: ID 093a:2510 Pixart Imaging, Inc. Optical Mouse(USB mouse on USB-2COM-BB)
Bus 002 Device 001: ID 1d6b:0002 Linux Foundation 2.0 root hub(BeagleBone USB2.0 hub)

8. You can key-in the command to find the available serial ports. Most likely, Angstrom Linux will support the two serial ports of USB-2COM-BB with ttyUSB0 and ttyUSB1:

You can check the two serial ports by key-in the following commands.

```
# stty -F /dev/ttyUSB0
```

```
# stty -F /dev/ttyUSB1
```

If two serial ports of USB-2COM-BB are available, the response is similar to

```
Speed 9600 baud; line = 0;
```

```
-brkint -imaxbel
```

```
root@beaglebone:~# stty -F /dev/ttyUSB0  
speed 9600 baud; line = 0;  
-brkint -imaxbel  
root@beaglebone:~#  
root@beaglebone:~# stty -F /dev/ttyUSB1  
speed 9600 baud; line = 0;  
-brkint -imaxbel
```

BUY ON
www.cablematic.com

9. You can also key-in the command to find the available Micro SD memory card. Most likely, Angstrom Linux will support Micro SD memory card of USB-2COM-BB with sda : You can check the Micro SD memory card by key-in “dmesg | grep sd” command. When done, you will find following message :

```
root@beaglebone:~# dmesg | grep sd
[  2.476654] sd 0:0:0:0: Attached scsi generic sg0 type 0
[  2.753845] sd 0:0:0:0: [sda] 8054784 512-byte logical blocks: (4.12 GB/3.84
GiB)
[  2.754638] sd 0:0:0:0: [sda] Write Protect is off
[  2.754638] sd 0:0:0:0: [sda] Mode Sense: 03 00 00 00
[  2.755401] sd 0:0:0:0: [sda] No Caching mode page present
[  2.761138] sd 0:0:0:0: [sda] Assuming drive cache: write through
[  2.771179] sd 0:0:0:0: [sda] No Caching mode page present
[  2.776977] sd 0:0:0:0: [sda] Assuming drive cache: write through
[  2.785430] sda: sda1 sda2
[  2.788391] sd 0:0:0:0: [sda] No Caching mode page present
[  2.794189] sd 0:0:0:0: [sda] Assuming drive cache: write through
[  2.800567] sd 0:0:0:0: [sda] Attached SCSI removable disk
root@beaglebone:~#
root@beaglebone:~# |
```



BUY ON
www.cablematic.com