

REV.	REVISED DESCRIPTION	DATE	CHECKED
A1	FIRST RELEASE	2010.4.17	

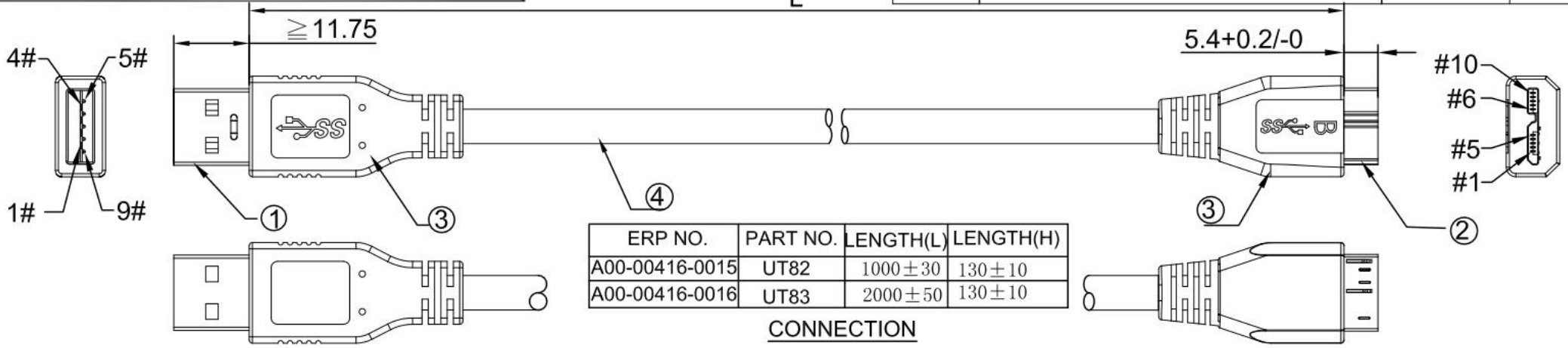

ERP NO.	PART NO.	LENGTH(L)	LENGTH(H)
A00-00416-0015	UT82	1000 ± 30	130 ± 10
A00-00416-0016	UT83	2000 ± 50	130 ± 10

CONNECTION

USB 3.0 A/P

Micro USB3.0 B/P

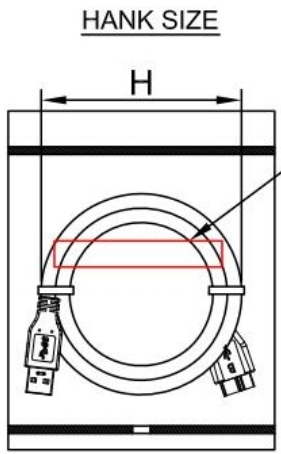

ERP NO.:	Label Text
A00-00416-0015	REF: UT82 Cable SuperSpeed USB 3.0(AM/MicroUSB-M) 1m
A00-00416-0016	REF: UT83 Cable SuperSpeed USB 3.0(AM/MicroUSB-M) 2m

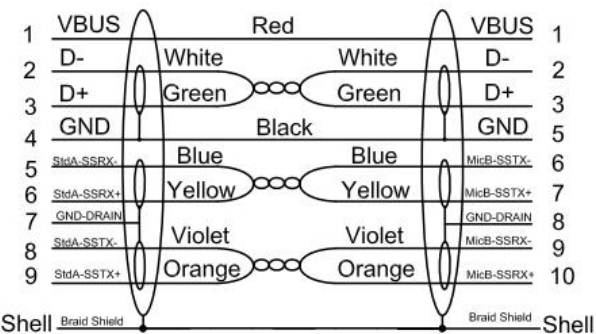

ELECTRIC TESTING

- 100% OPEN & SHORT TESTING
- INSULATION RESISTANCE: $\geq 20M \Omega$
- CONDUCTOR RESISTANCE: $\leq 5 \Omega$
- VOLTAGE: 500V DC/0.1S

1PC Cable / PE Bag

ITEM	SPECIFICATION
4	Cable Spec(C08-516M1*): {[7/0.127Tc+FM-PE]*1P+7/0.10Tc+AL+Mylar]*3P+(7/0.20Tc+SR-PVC)*2C+Filler+AL+16/6/0.10Tc}*1C O.D.:5.5mm Out Jacket:Blue Half Matt PVC (Low toxic)
3	PVC-Blue 60P (Pantone No:301U)
2	Micro USB B Type Plug(REV. 3.0)-Nickel Plated
1	USB A Type Plug(REV. 3.0)-Nickel Plated(YT-1710/1666)

TOLERANCES UNLESS OTHERWISE STATED

X.	= ± 1
.X	= ± 0.2
.XX	= ± 0.1

ERP NO.:	A00-00416-001*	SAMPLE DWG NO.:	
DOC No.:		REVISION	1.0
CUSTOMER:	FAST	UNIT	MM
CUSTOMER P/N:	UT8*	SCALE	NO
DESCRIPTION	USB A/P- Micro USB B/P (REV. 3.0)	PAGE NO	1/1
APPROVAL	CHECKED	DATE	2010.4.17
		DRAWN	YJ