

Luis Bellassai

PRODUCTION AND SCENIC DESIGNER

Email: Luisbellassaigauto@gmail.com

Cell: 778 317 2791

Vancouver – Canada

RESUME +
PORTFOLIO



INDEX

ARTISTIC RESUME

CANADIAN EXPERIENCE

- The Changeling – Scenic Design
From paper to the real stage
Technical drawings
- Goldrausch – Scenic Design
From paper to the real stage
Graffiti Design for the stage
- Airs and Graces – Production Design
Photos and sketches
- Sunrise Valley – Production Design
From paper to set
- Bridges – Production Design
Photos of the set and props

INTERNATIONAL EXPERIENCE

- The Gold Seekers (Los Buscadores) – Prop Master
- Advertisement and Commercials Set design
Tokyo - Brand of appliance - TV Commercials
MOBIL Lubricant brand - TV Commercial
Cerro Porteno Soccer team - TV commercial

ADDITIONAL SKILLS

- Scale Models
- Costume Design and Coordination
- Drawings and sketches
- Architecture Design
Summer House Residential Design
Lambare project – Care Home Design





CANADIAN EXPERIENCE	
	Scenic Design
2023	Set and Props for the Jr and Sr Theatre Troupe Productions. Arts Umbrella. <i>Vancouver – Canada.</i>
2020	“The Changeling”. Telus Studio Theatre, UBC. <i>Vancouver - Canada.</i>
2019	“Goldrausch” Frederick Wood theatre, UBC. – <i>Vancouver - Canada.</i>
	Production design
2020	“Bridges” short film. Vancouver – Canada.
2020	“Airs and Graces” short film. <i>Vancouver - Canada.</i>
2019	“Sunrise Valley” Feature Film Teaser – UBC. <i>Vancouver - Canada.</i>
	Set assistance
2021	“Emilia”. Jericho Arts Centre. <i>Vancouver - Canada.</i>
INTERNATIONAL EXPERIENCE	
	Art director and crew on set
2016 to 2018	Several commercials and TV spots
	Props master
2016	Featured film “The Gold Seekers” (Los Buscadores) directed by Maneglia-Schémbori. (Premiered October 2017)
	Art director
2014	“Jeuji”, directed by Nancy García. (Premiered October 2016)
2013	“Leona” short film within the framework of Mercosur Audiovisual.
2013	“On the third day” (Y al Tercer Día) Short Film, directed by Osvaldo Ortiz Faiman.

- **Master of Fine Arts in Theatre Design and Production, University of British Columbia.**
Vancouver B.C. - Canada
2018-2020
- **BC Building codes Part 3 –**
Course completed
Vancouver B.C. - Canada
2023
- **Undergraduate studies, Architecture**
Catholic University “Nuestra Señora de la Asunción”
Asunción - Paraguay
2013
- **Diploma, Acting** Centre of Theatrical Divulcation and Research “El Estudio.”
Asunción - Paraguay
2010- 2012

SKILLS

- Creative design oriented
- Free-hand sketching
- Arts and craft
- Project management
- Budgeting – estimating

LANGUAGES SKILLS

- Critical thinking
- Team management
- Problem-solving
- Collaboration
- Communication
- English
- Spanish
- Portuguese

SOFTWARES

- Sketchup
- Autocad - Autodesk
- Adobe Photoshop and Illustrator
- Krita – Digital Graphic Editor
- Revit - Autodesk

TRADE SKILLS

- Carpentry assistance
- Painting





CANADIAN EXPERIENCE

- ***Pre production:***
Production Design
Set Design
Set Decoration
Production Design Assistance
Carpentry
Painting
- ***On set:***
Production design
Prop Master
Set Dressing
Set Assistance
- ***Softwares:***
Sketchup
Autocad
Photoshop
Krita

The Changeling – Scenic Design

ORIGINAL PLAY ON STAGE

Director Luciana Silvestre
Fernandez;

Scenic Design Luis Bellasai;
Costume Design Charlotte Di
Chang;

Lighting Design Zach Levis;

Sound Design Jacob Wan;

Stage Manager Anita Jian.

Production: UBC - THEATER
AND FILM - 2020

Location: Telus Studio Theatre
- UBC. Canada.



Media cover:

<https://www.vancouverplays.com/review-theatrefilm-ubc-the-changeling-20.shtml>

Photo: Javier Sotres

Project selected to represent Canada at the WORLD STAGE DESIGN EXHIBITIONS 2022- Calgary 2022

From paper to
the real stage

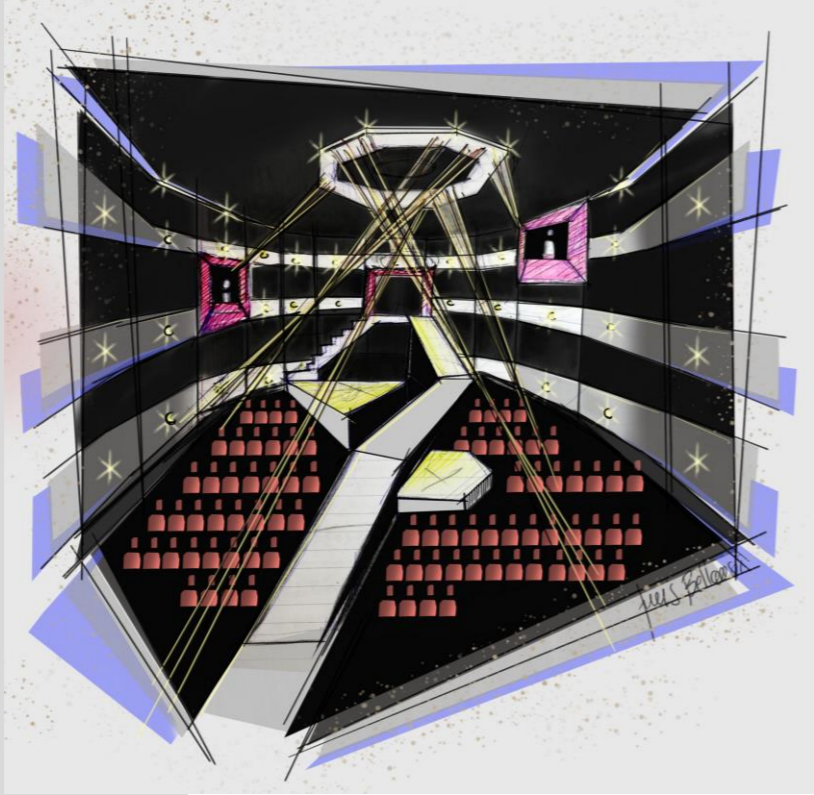

Desired stage effect



Set under construction

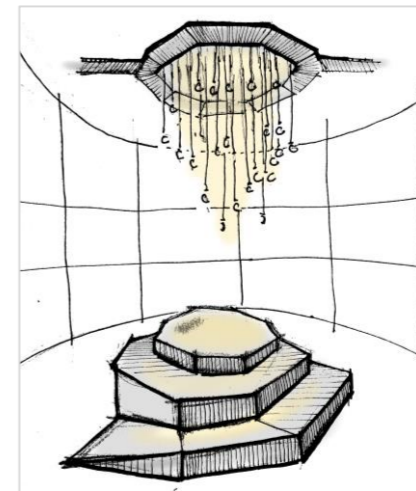
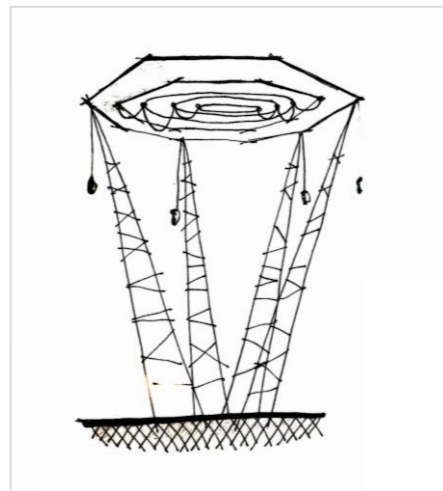
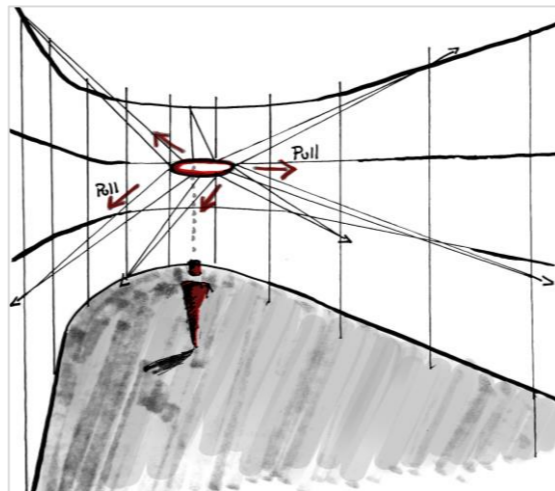

Preliminary sketches and ideas



Photo: Javier Sotres



Photo: Javier Sotres

Goldrausch – Scenic Design

ORIGINAL PLAY ON STAGE

Director Luciana Silvestre
Fernandez;

Scenic Design Luis Bellasai;

Costume Design Charlotte Di
Chang;

Lighting Design Zach Levis;

Sound Design Jacob Wan;

Stage Manager Anita Jian.

Production: UBC - THEATER
AND FILM - 2020

Location: Telus Studio Theatre
- UBC. Canada.



From paper to the real stage

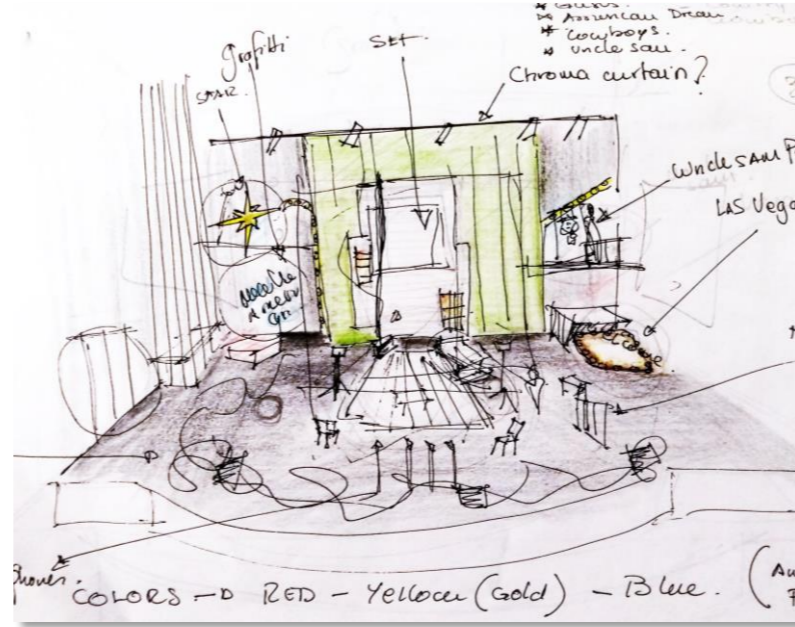

Preliminary sketch

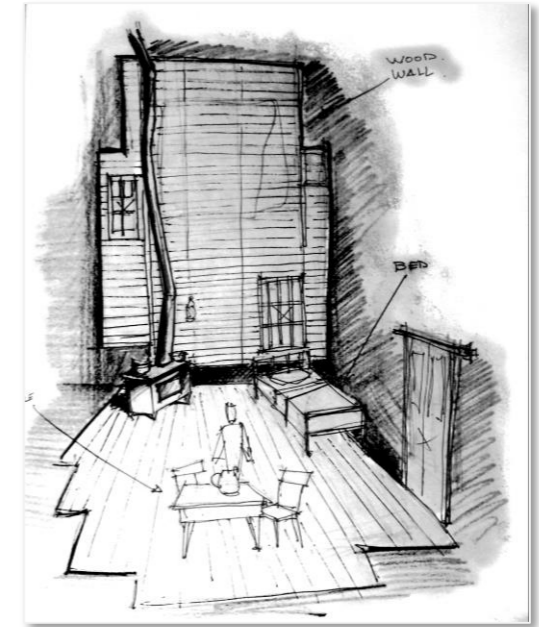

Sketch 2

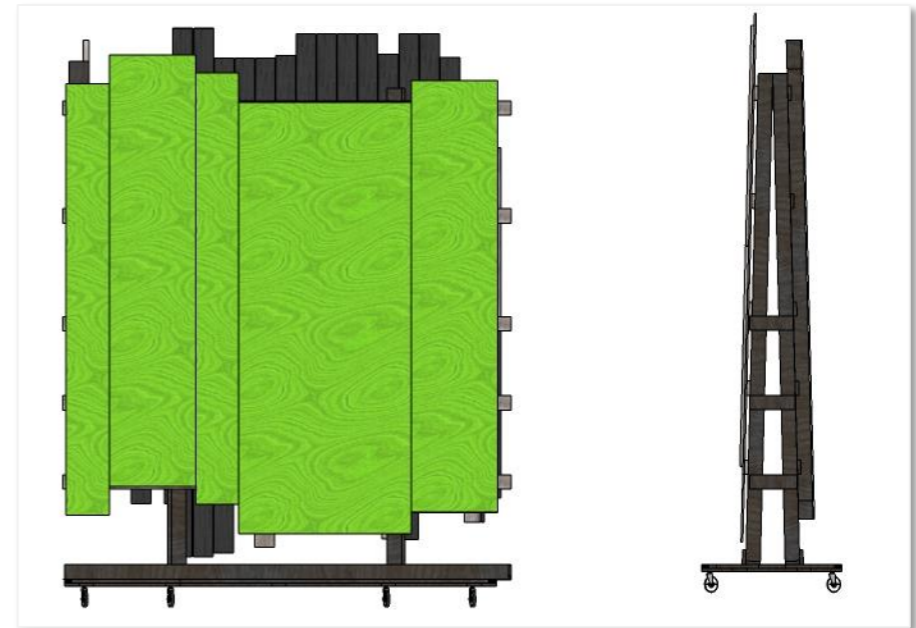
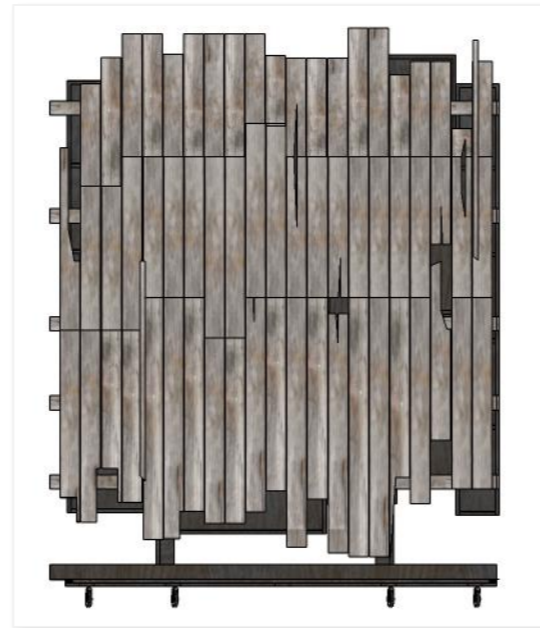

Graffiti Design for the stage

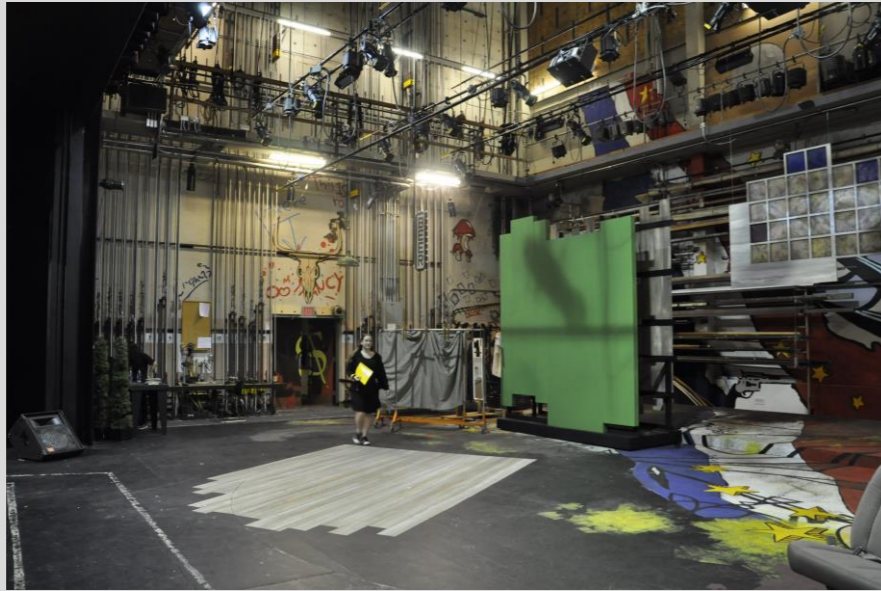

Graffiti result on stage left



Graffiti result on stage right

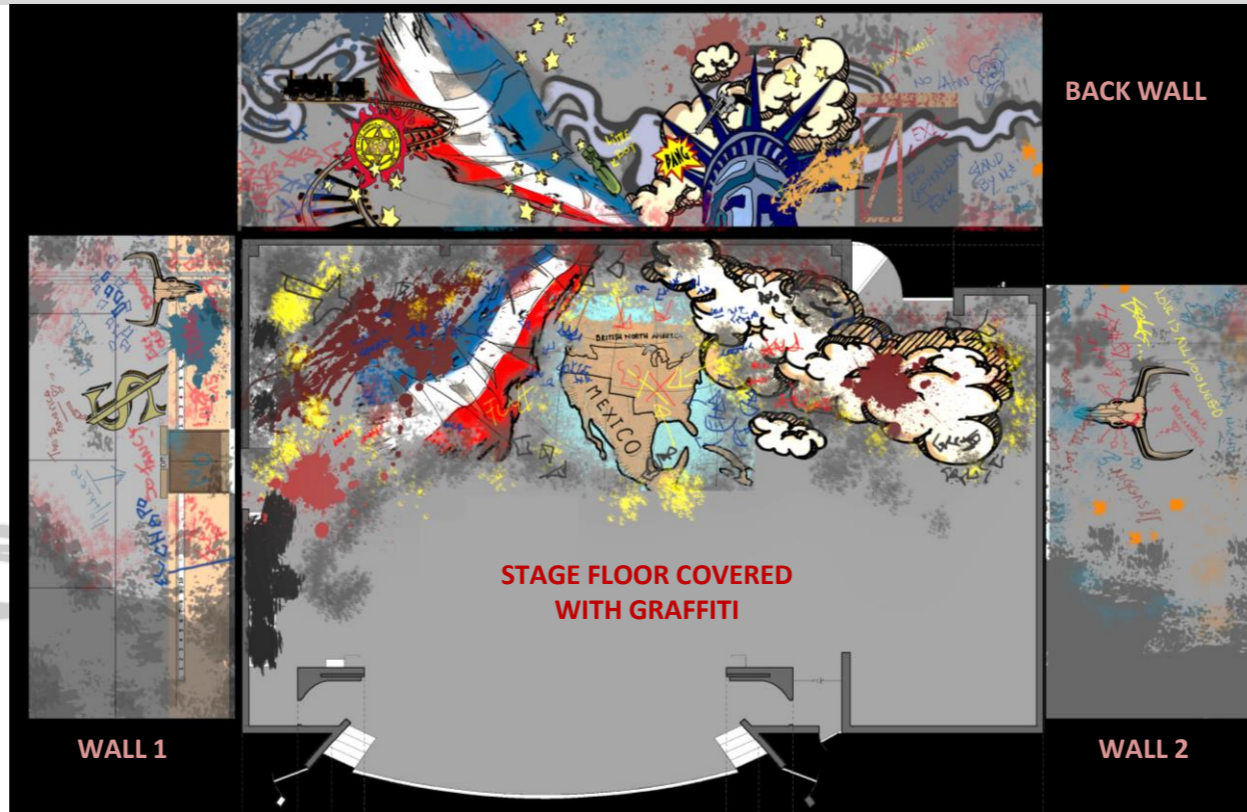

Airs and Graces – Production Design

Short film 2020

Written and Directed: Rose Paine

Produced: Rose Paine, Janya Cambronero Severin, Natanael Cambronero Severin

Cinematography: Natanael Cambronero Severin

Production Design: Luis Bellasai and Cecilia Vadala

IMDB PROFILE:

https://www.imdb.com/title/tt14757830/?ref=ttfc_fc_tt



Sketches and Photos of the Living Room

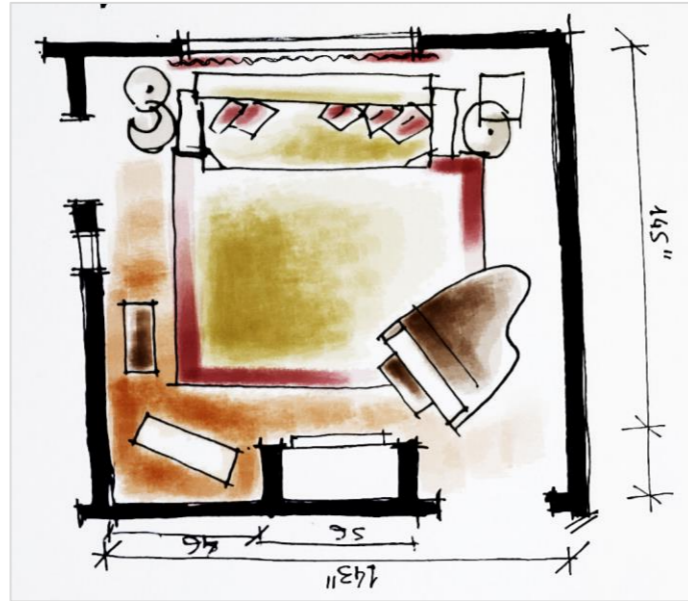

Sketches and Photos of the Dining Room

Dining room sketches and perspective

Set pieces and props

Color- shapes and textures

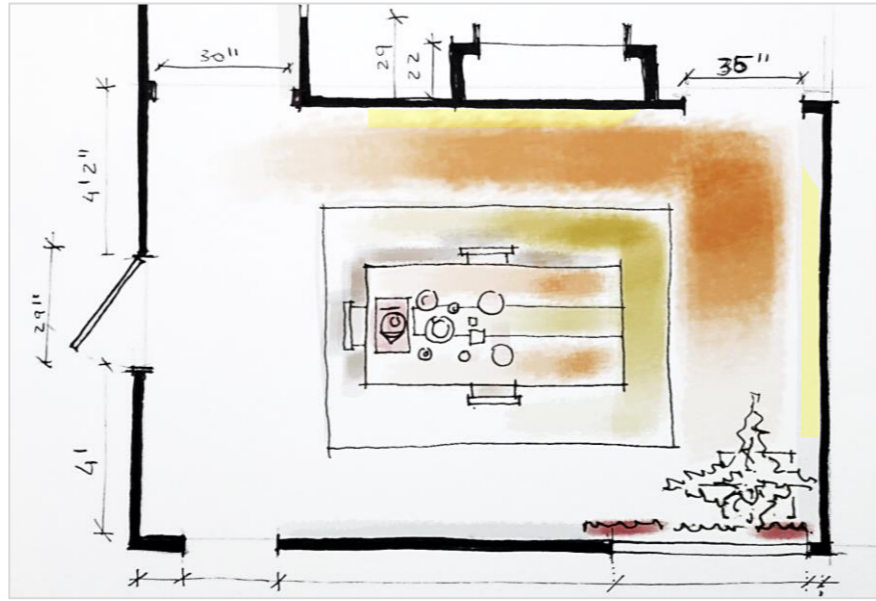

Floor plan sketch

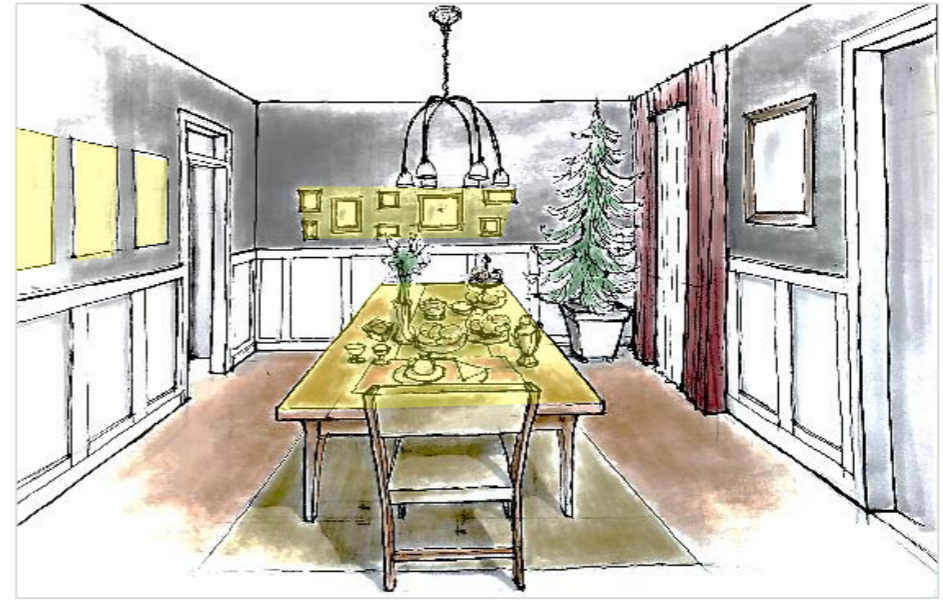

Perspective sketch



Consumable prop on set



Dining room and table decoration



Consumable prop on set

Photos of Bedroom and Customized Props

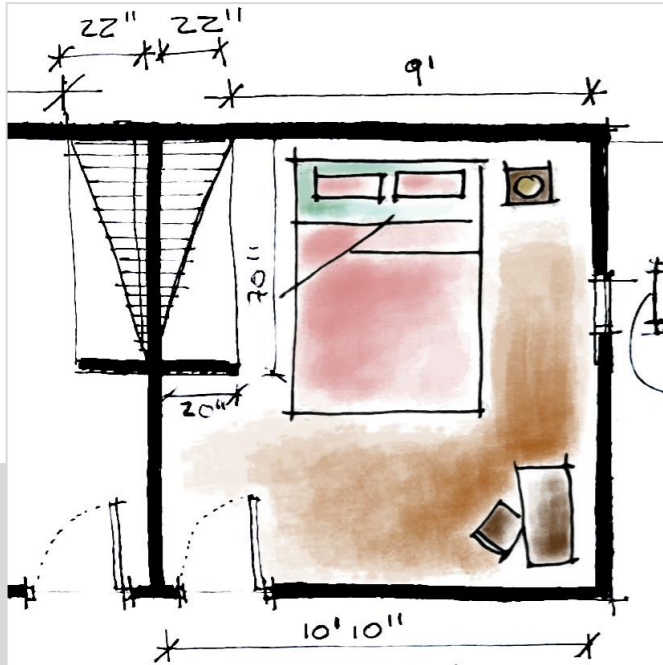

Floor plan sketch



Bed room
Decoration and Props to be used on set
Wall papers
Bed dressing
Combination of color texture



Bedroom View 1



Bedroom View 2



Bedroom View 3

Sunrise Valley – Production Design

Feature film teaser 2019

Written and Directed:

Samantha Pineda Sierra and
Davy Giorgi

Cinematography: Esteban
Robles

Produced: Samantha Pineda
Sierra and Jason Karman
OPIA

Production Design:

Luis Bellassai and Cecilia Vadala



From paper to set

A dystopian health care center for the elderly
An old fashion and anachronistic emergency room

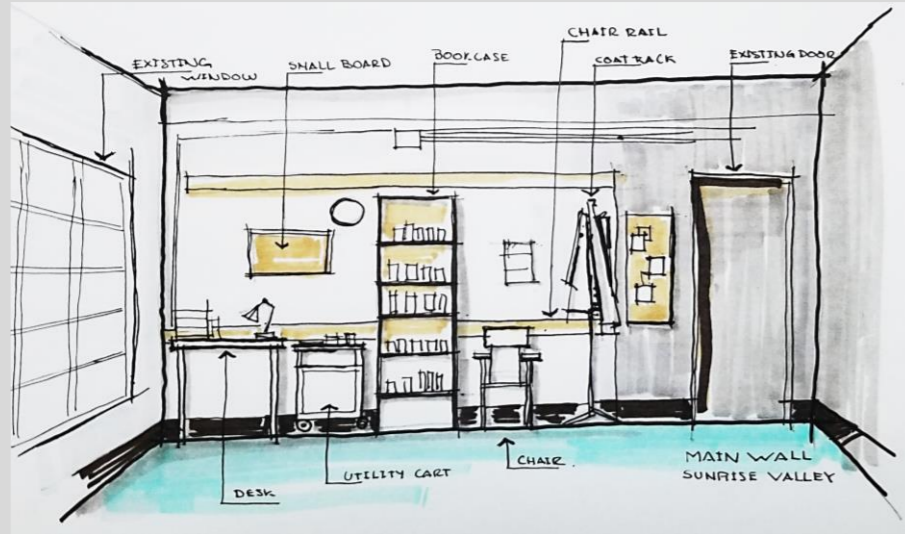

Front view sketch



3D view – Sketchup Pro



View of the set



Props

Bridges – Production Design

Short film

Written by Aidan Leonard, Nouver Cheung, Ian Tan

Direction Ian Tan

Production Donna Cheung, Aidan Leonard, Ashwin Maharaj

Cinematography Shiun Okada

Production Design Luis Bellassai Gauto and Cecilia Vadala

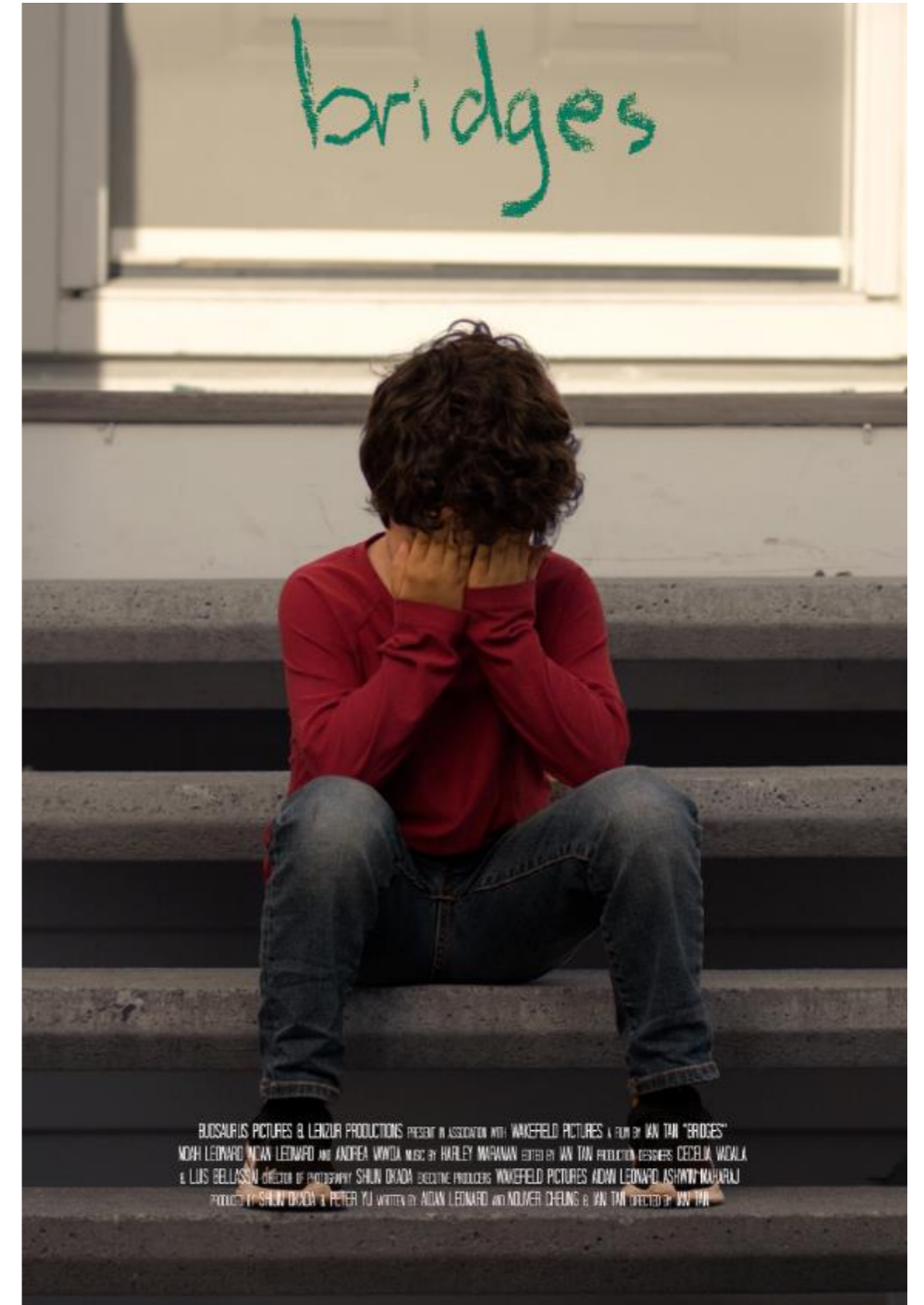

BLOSSAURUS PICTURES & LEIZUR PRODUCTIONS PRESENT IN ASSOCIATION WITH WAKEFIELD PICTURES A FILM BY IAN TAN "BRIDGES"
WRITTEN BY AIDAN LEONARD, NOUVER CHEUNG AND IAN TAN. MUSIC BY HARLEY MARGANAN. EDITED BY IAN TAN. PRODUCTION DESIGNERS: CECILIA VADALA
& LUIS BELLASSAI. DIRECTOR OF PHOTOGRAPHY: SHIUN OKADA. EXECUTIVE PRODUCERS: WAKEFIELD PICTURES, AIDAN LEONARD, ASHWIN MAHARAJ.
PRODUCED BY SHIUN OKADA & PETER YU. WRITTEN BY AIDAN LEONARD AND NOUVER CHEUNG & IAN TAN. DIRECTED BY IAN TAN.

Photos of the set and props

Design intention
Set and props for an architecture home studio of a divorced father.



INTERNATIONAL EXPERIENCE



- ***Pre production:***
Production Design
Set Design
Set Decoration
Production Design Assistance
- ***On set:***
Production Design
Prop Master
Set Dressing
Set Assistance
- ***Softwares:***
Sketchup
Autocad
Photoshop

The Gold Seekers (Los Buscadores) – Prop Master

Feature Film

Prop master Luis Bellasai
Pre- production and work on set

Production designer Carlos Spatuzza

Scenic designer Dulce Centurion

Assistants: Raul Paniagua, Jonny Medina, Claudio Toledo, Felipe Rojas

Director Juan Carlos Maneglia Tana Schembori;

Official trailer link:

https://www.youtube.com/watch?v=C_MHBXlwynE

Hollywood reporter review link:

<https://www.hollywoodreporter.com/review/gold-seekers-review-1050989>



Advertisement and Commercials Set design

Set design and Set dressing:
Luis Bellassai
Production design
assistance: Luis Bellassai

Production designer: Dulce
Centurion.



On set result



3D digital Model

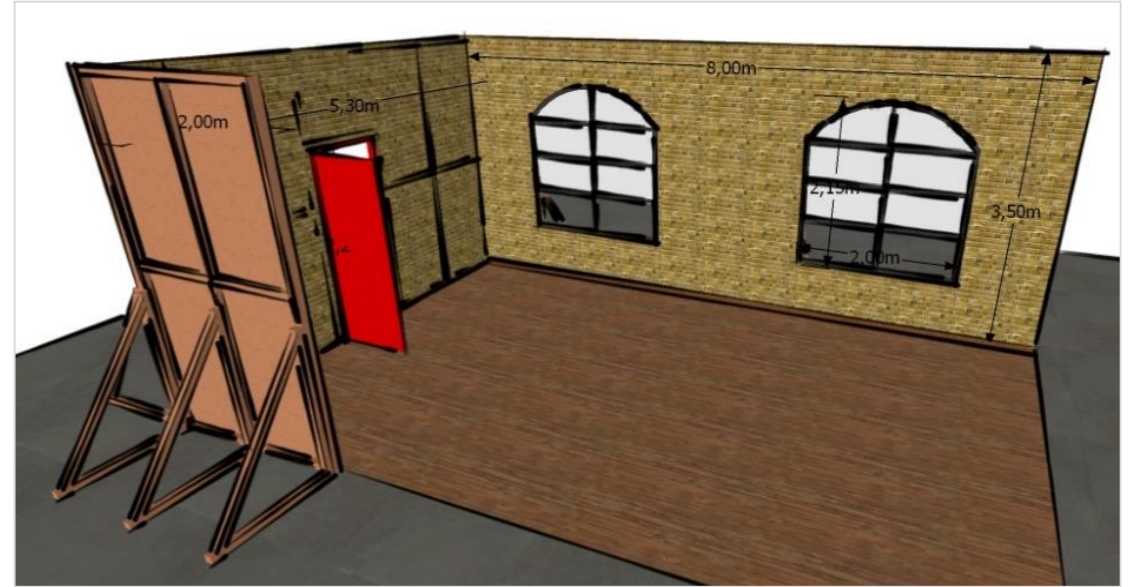

3D digital Model



Tokyo - Brand of appliance TV Commercials

Set design and Set dressing: Luis Bellassai
Production design assistance: Luis Bellassai
3D Model on Sketch-up.

Production designer: Dulce Centurion .

Video Link: Final result
<https://www.facebook.com/tokyopy/videos/vl.131577924102235/1736108949809264/?type=1>



On set result



3D digital Model

**MOBIL LUBRICANT
BRAND
TV Commercial**

Set design and Set dressing:

Luis Bellasai

Production design assistance:

Luis Bellasai

3D Model on Sketch-up.

Production designer: Dulce

Centurion.

Video link:

<https://www.facebook.com/watch/?v=10156167395346351>

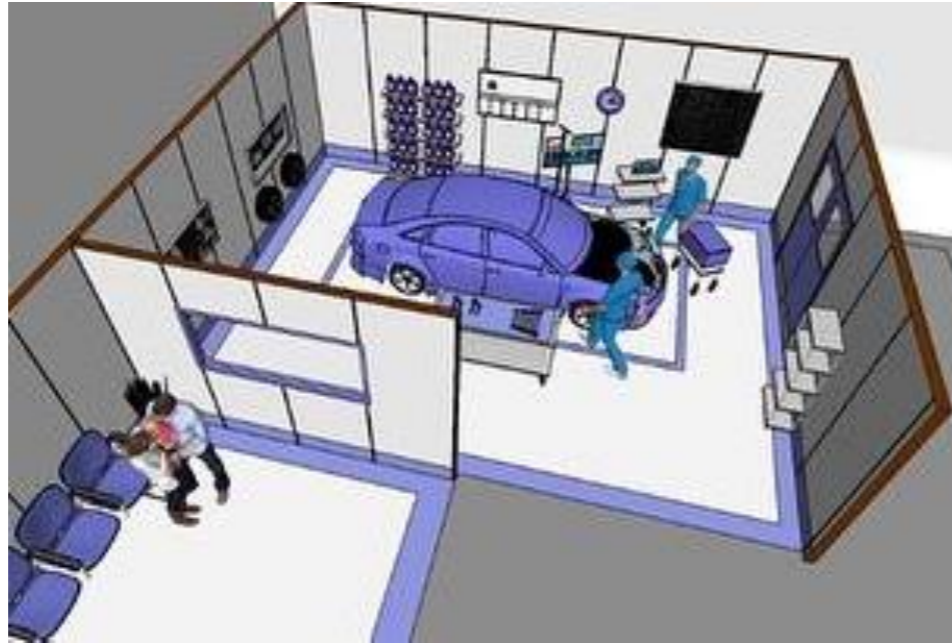

3D digital Model



On set result



TV commercial

Cerro Porteno
Soccer team

Production designer: Luis Bellasai
Pre- production and on set work

Assistants: Raul Paniagua
Claudio Toledo

Video link:
<https://www.facebook.com/ccpoficial/videos/1627168507315177>

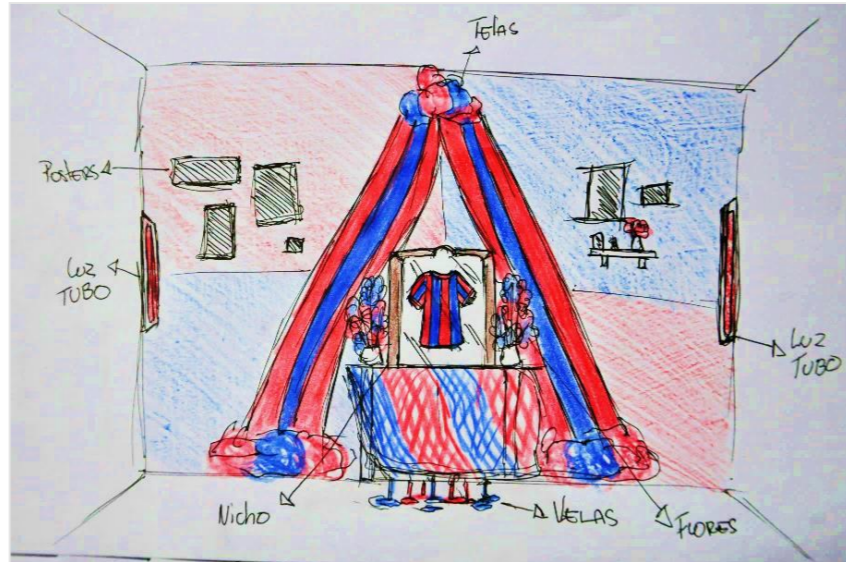

Quick sketch – Altar



On set result



News paper cover design and print



ADDITIONAL SKILLS

- **Works include:**
Real Scale Models
Costume Design and Coordination
Drawings and sketches
Architecture Design
- **Softwares:**
Sketchup
Autocad
Photoshop
Krita



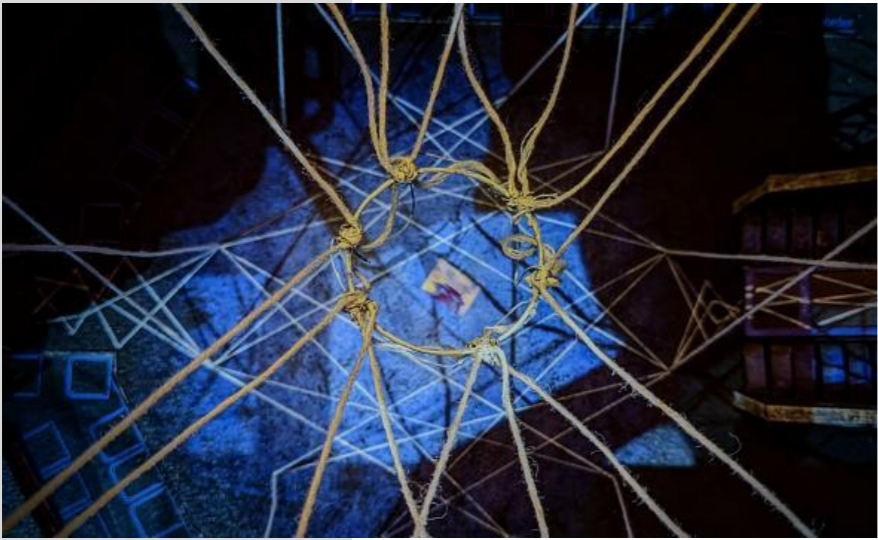

The Changeling 2020



Buried Child 2019



Studio Model 2018

Costume Design and Coordination

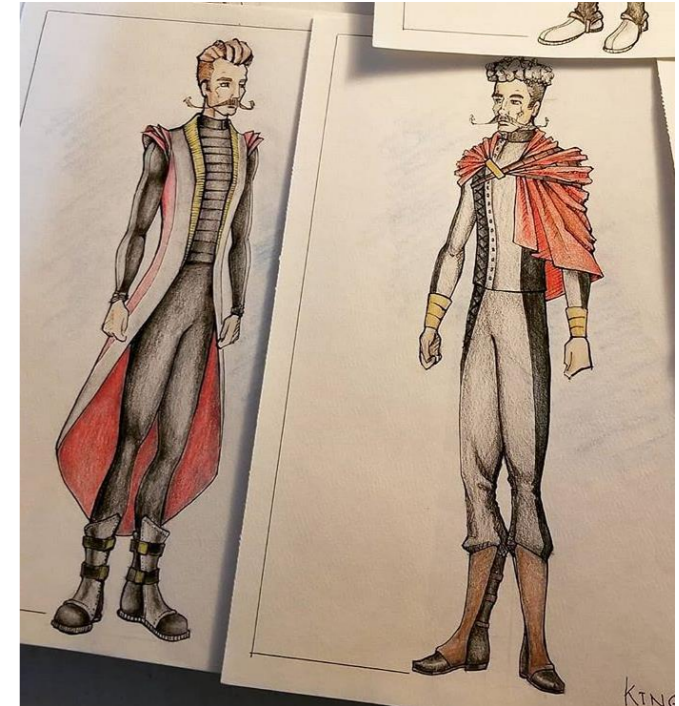

Digital and paper sketches



Play: Problem child UBC 2019

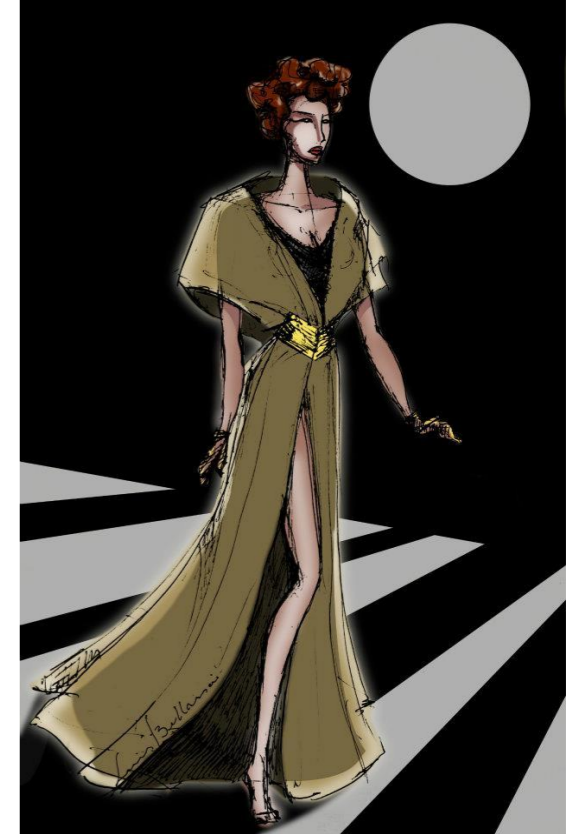

Digital Illustration

Summer House

Role

Architecture design

Technical drawing

Residential Floor Plan

SOFTWARE

Autocad
Sketchup
Vray
Photoshop

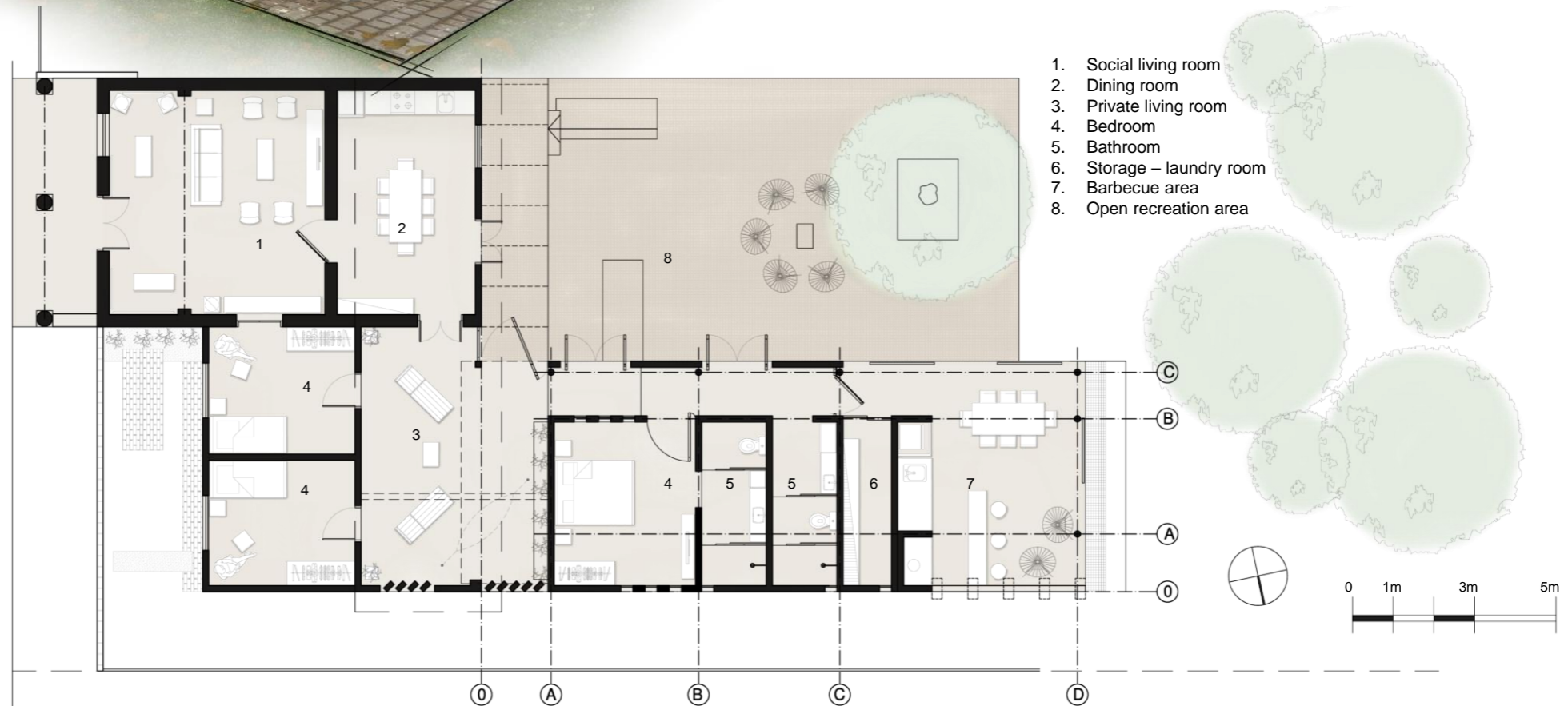



LAMBARE PROJECT – Care Home

ARCHITECT: Luis Bellassai - Marcelo Da Silva

Construction Manager: Luis Bellassai - Marcelo Da Silva

Client: Daughters of Charity of Saint Vincent de Paul.

Square footage: The project has a total construction area of 9,400 SF.

Location: Lambaré – Paraguay

Financial sponsor: ADVENIAT PARIS <https://adveniat-paris.org/fr/>

The whole development was built in 4th Phases starting in 2017 and finishing in 2018.

Years: 2017 - 2018

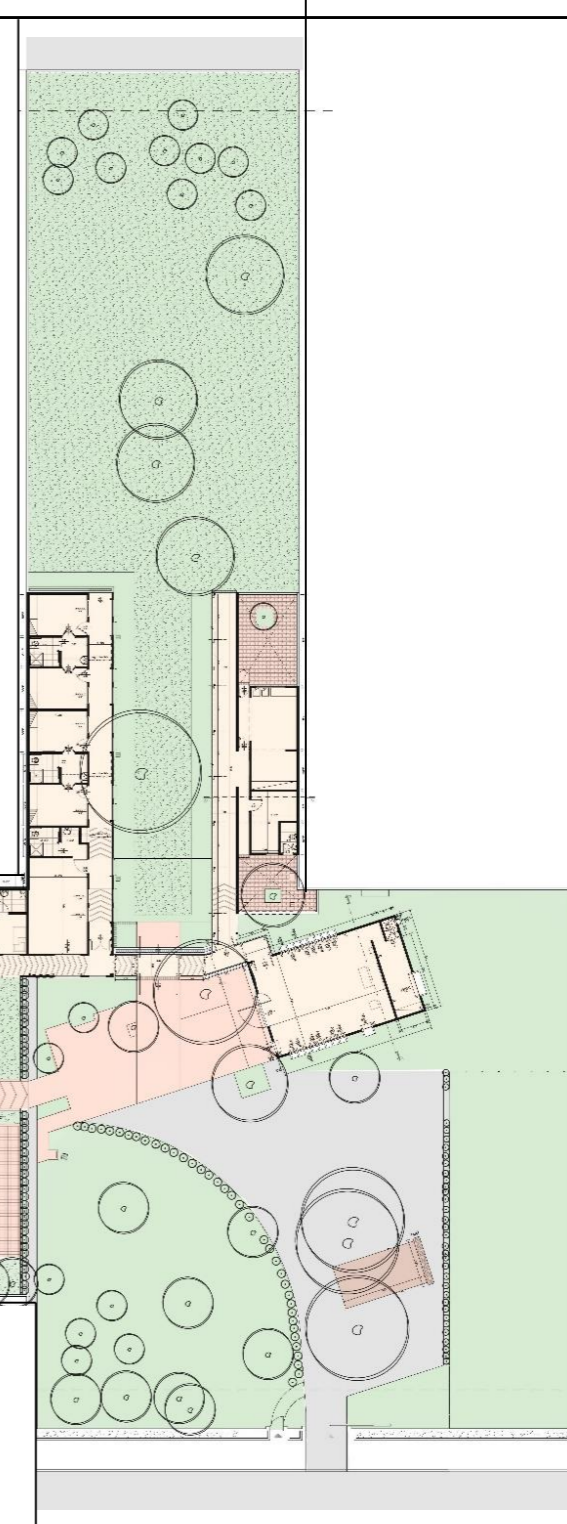

Role

ARCHITECT
CONSTRUCTION
MANAGER

Job done

- Concept ideas and planning
- Site plan checking
- Building space planning
- Building design management
- Project presentation
- Budgeting
- construction management

DRAWINGS

Main plan

SOFTWARE

Autocad
Photoshop
Adobe acrobat



Description: The project consists of the expansion and reorganization of a retirement center called Casa Santa Ana Isabel Seton.
 “The Association Daughter of Charity of Saint Vincent de Paul” needed to expand the entire venue.

DRAWINGS

Location plan
 Landscape and contour plan

SOFTWARE

Autocad
 PDF Acrobat

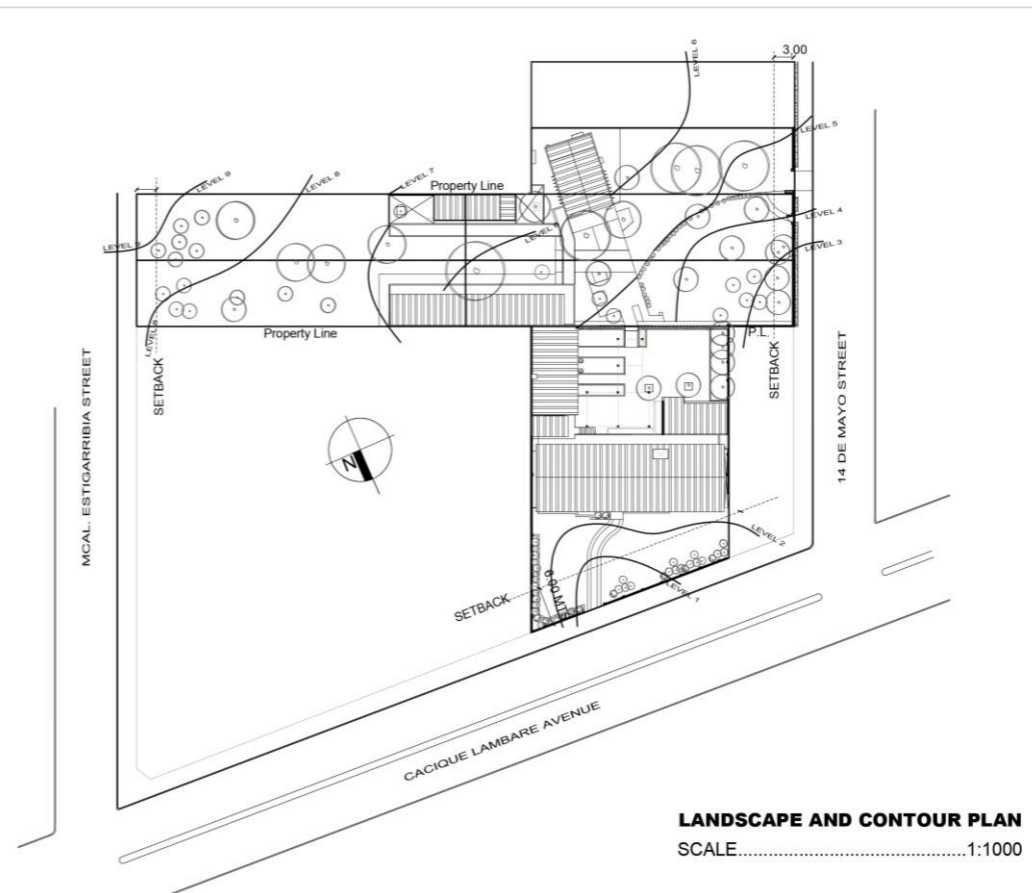
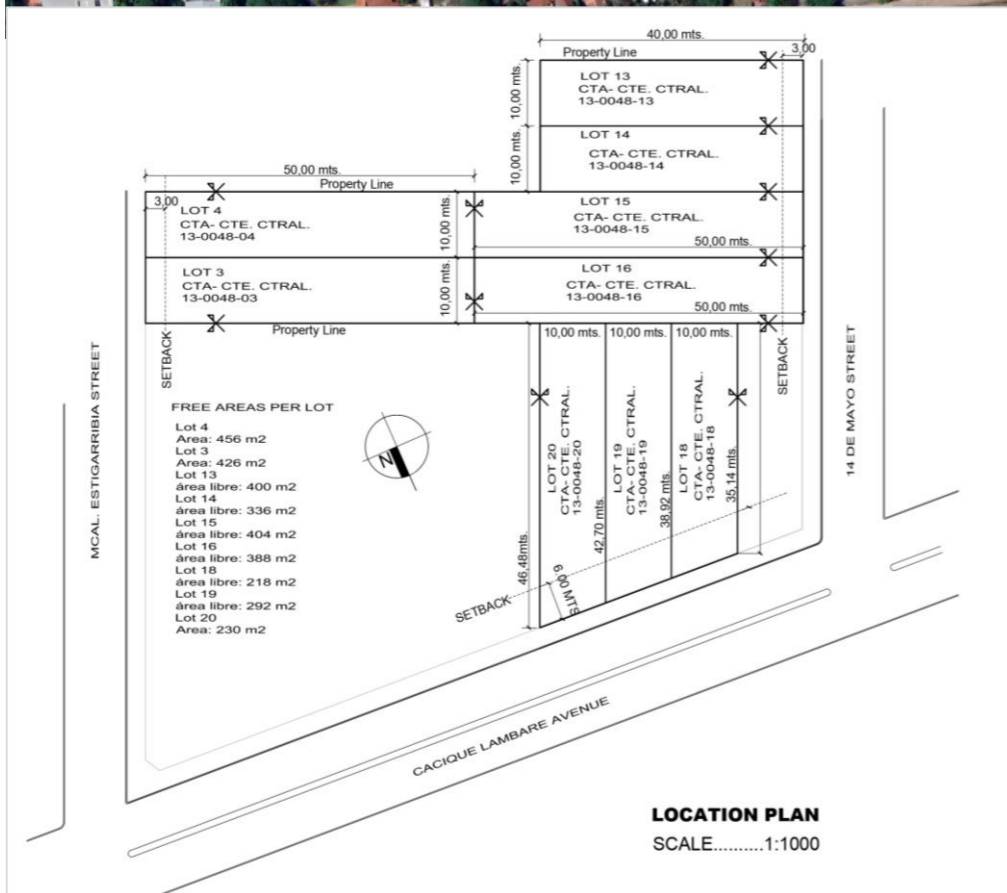



Materials and textures from Wood, bricks, metal and exposed concrete were used in the new areas.



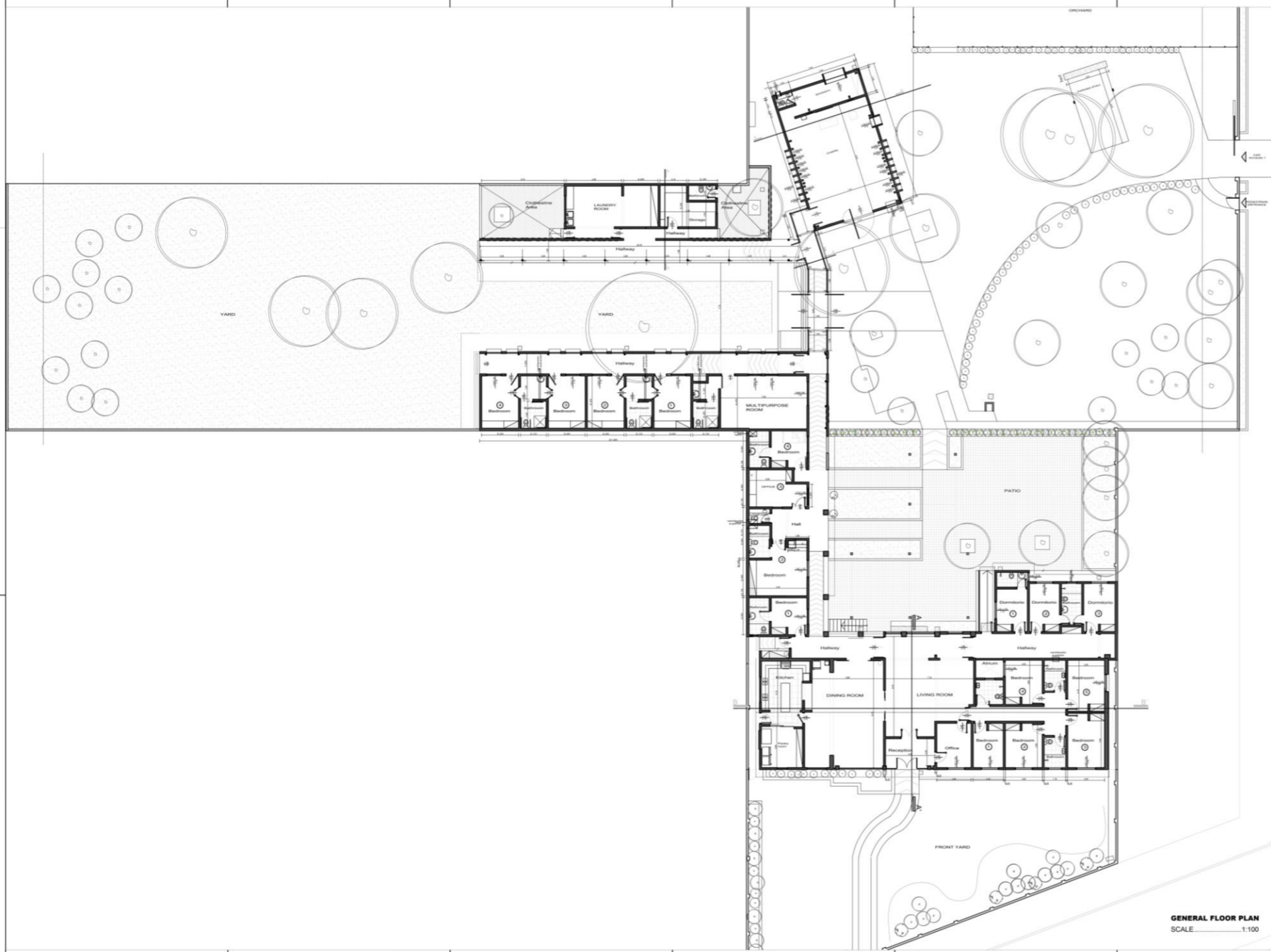

GENERAL FLOOR PLAN
SCALE.....1:100

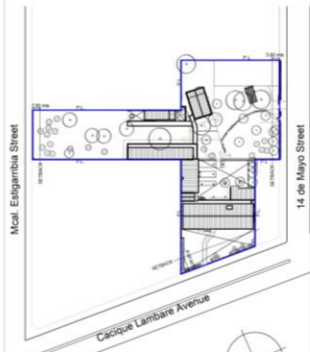

SITE PLAN
SCALE...1:750



GENERAL FLOOR PLAN
SCALE.....1:100

Project: Lambare House for Elderly
 ADDRESS: Avda. Mica. Estigarribia c/ Avda. Cacique Lambare
 CLIENT: Asociación Hijos de la Cuidad de San Vicente de Paul
 PROFESSIONAL: Arch. Luis Bellasai - Arch. Marcelo Da Silva REG. No:
 ADDRESS:
 BUILT AREA: 880 m2
 TOTAL AREA: 4021 m2
 CTA, CTE, CTRAL: 13-0048-18, 13-0048-19, 13-0048-20, 13-0048-03, 13-0048-04,
 13-0048-13, 13-0048-14, 13-0048-15, 13-0048-16

DATE: _____ PROFESSIONAL: _____

DRAWINGS

Site plan
 General Plan

SOFTWARE

Autocad
 PDF Acrobat

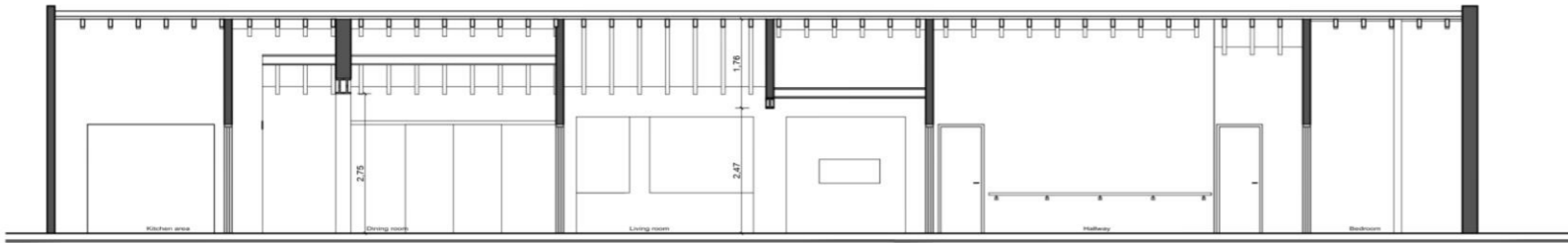

SECTION B-B'
Renovated Area



SECTION A-A' Living room

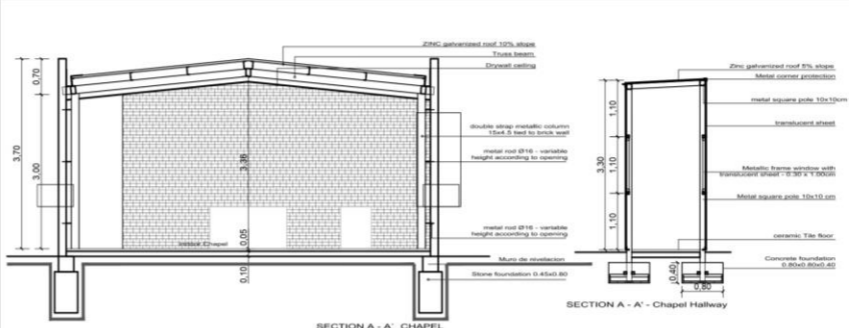

SECTION A-A' CHAPEL

SECTION A-A' - Chapel Hallway

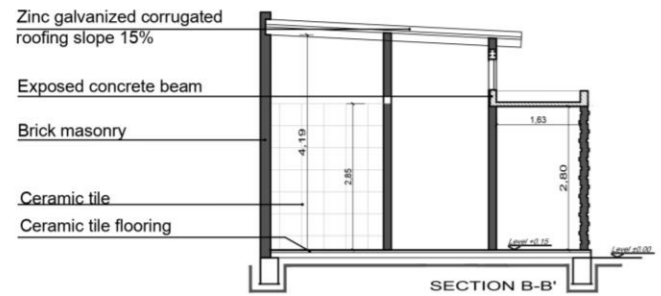

SECTION B-B'

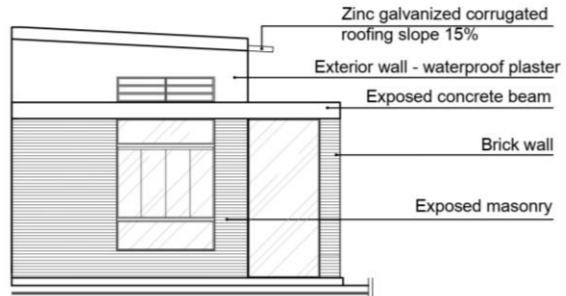

VIEW 1
New Bedroom Area

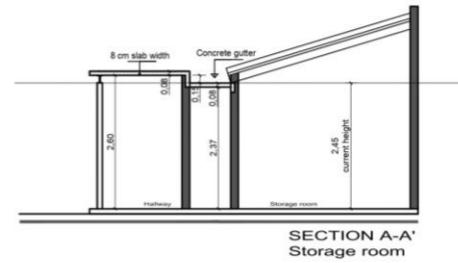

SECTION A-A'
Storage room

ELEVATIONS AND VIEWS
SCALE.....1:50

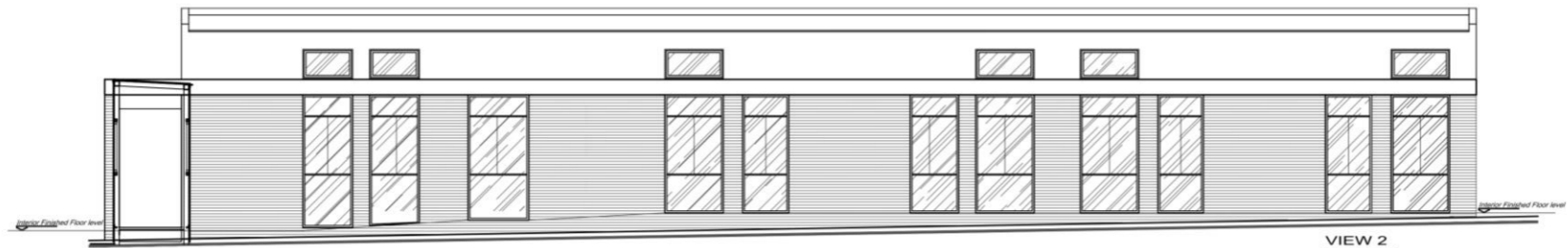

VIEW 2
New Bedroom area

Project: Lambare House for Elderly
 ADDRESS: Avda. Mca. Estigarribia c/ Avda. Cacique Lambaré
 CLIENT: Asociación Hijas de la Caridad de San Vicente de Paul
 PROFESSIONAL: Arch. Luis Bellasai - Arch. Marcelo Da Silva REG.No:
 ADDRESS:
 CONSTRUCTION AREA: 880 m2
 TOTAL AREA: 4021 m2
 CTA CTE. CTRAL: 13-0048-18, 13-0048-19, 13-0048-20, 13-0048-03, 13-0048-04,
 13-0048-13, 13-0048-14, 13-0048-15, 13-0048-16

CLIENT: PROFESSIONAL:

DRAWINGS

Elevations
and Sections

SOFTWARE

Autocad
Pdf Acrobat

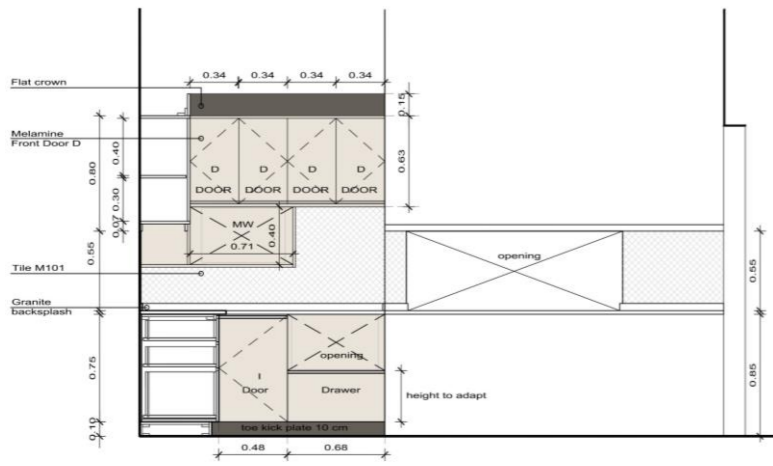

KITCHEN - SECTION A-A

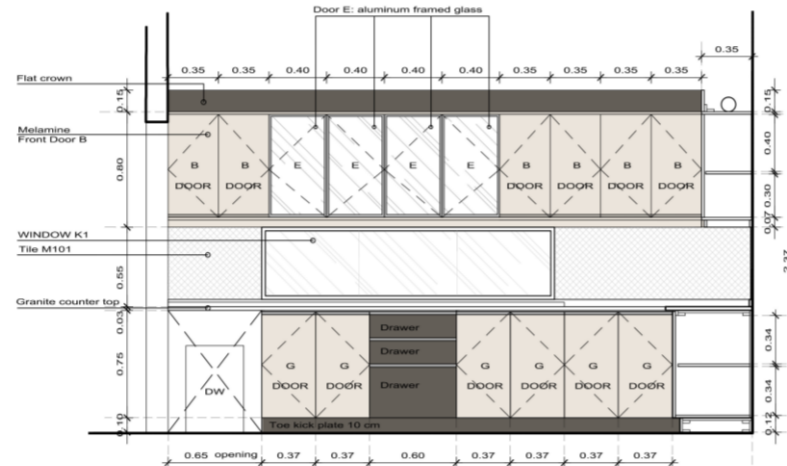

KITCHEN - SECTION B-B

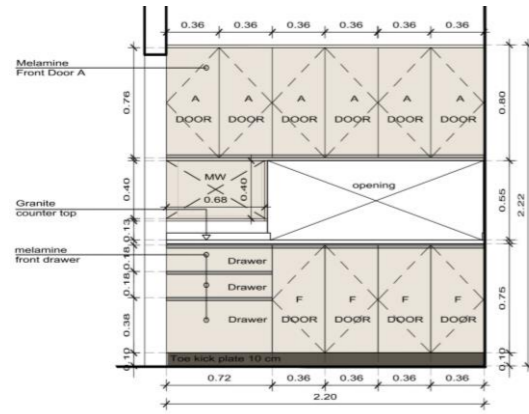

DINING AREA - SECTION C-C

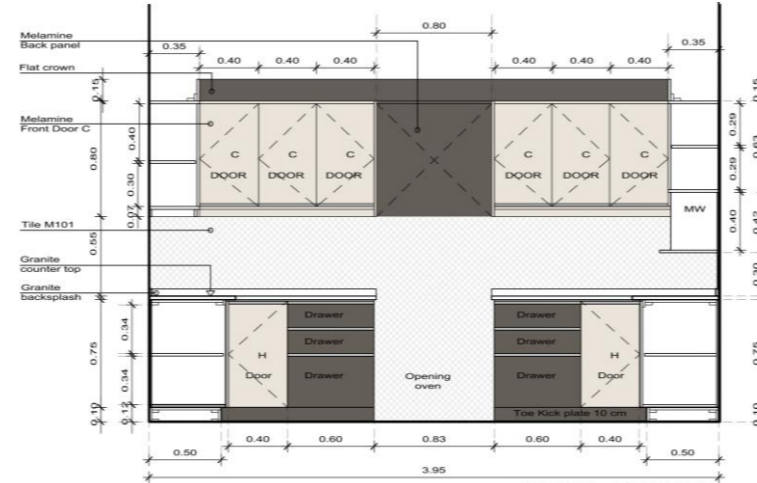

KITCHEN - SECTION D-D

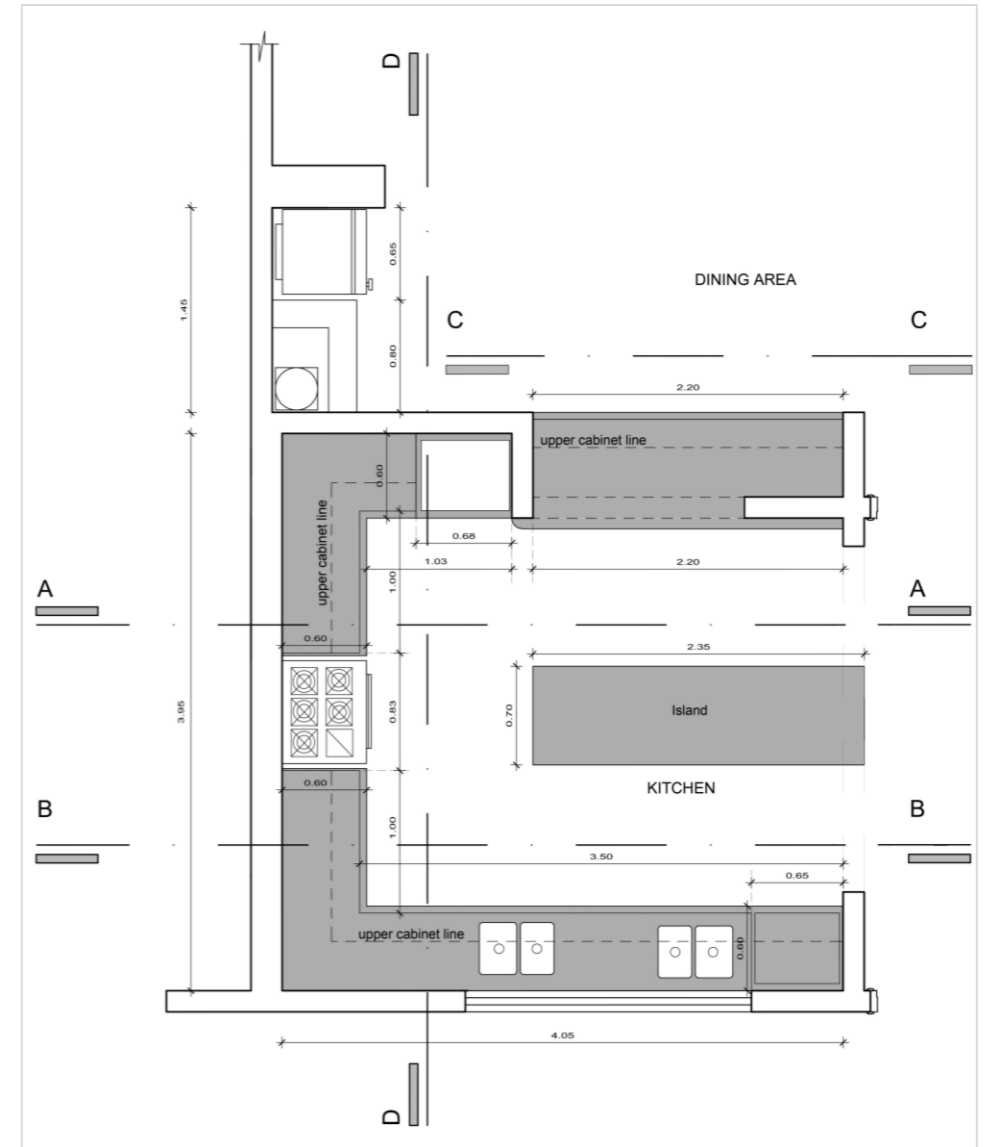

DRAWINGS
MILLWORK:
PLAN AND
ELEVATIONS

SOFTWARE
Autocad
Adobe acrobat