

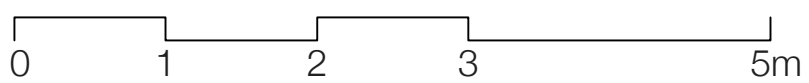

WONING LOT 1





WONING LOT 3

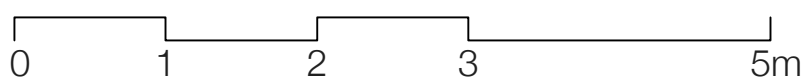



WONING LOT 1

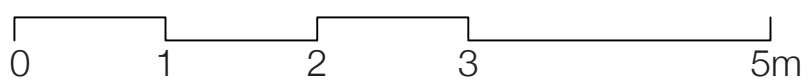

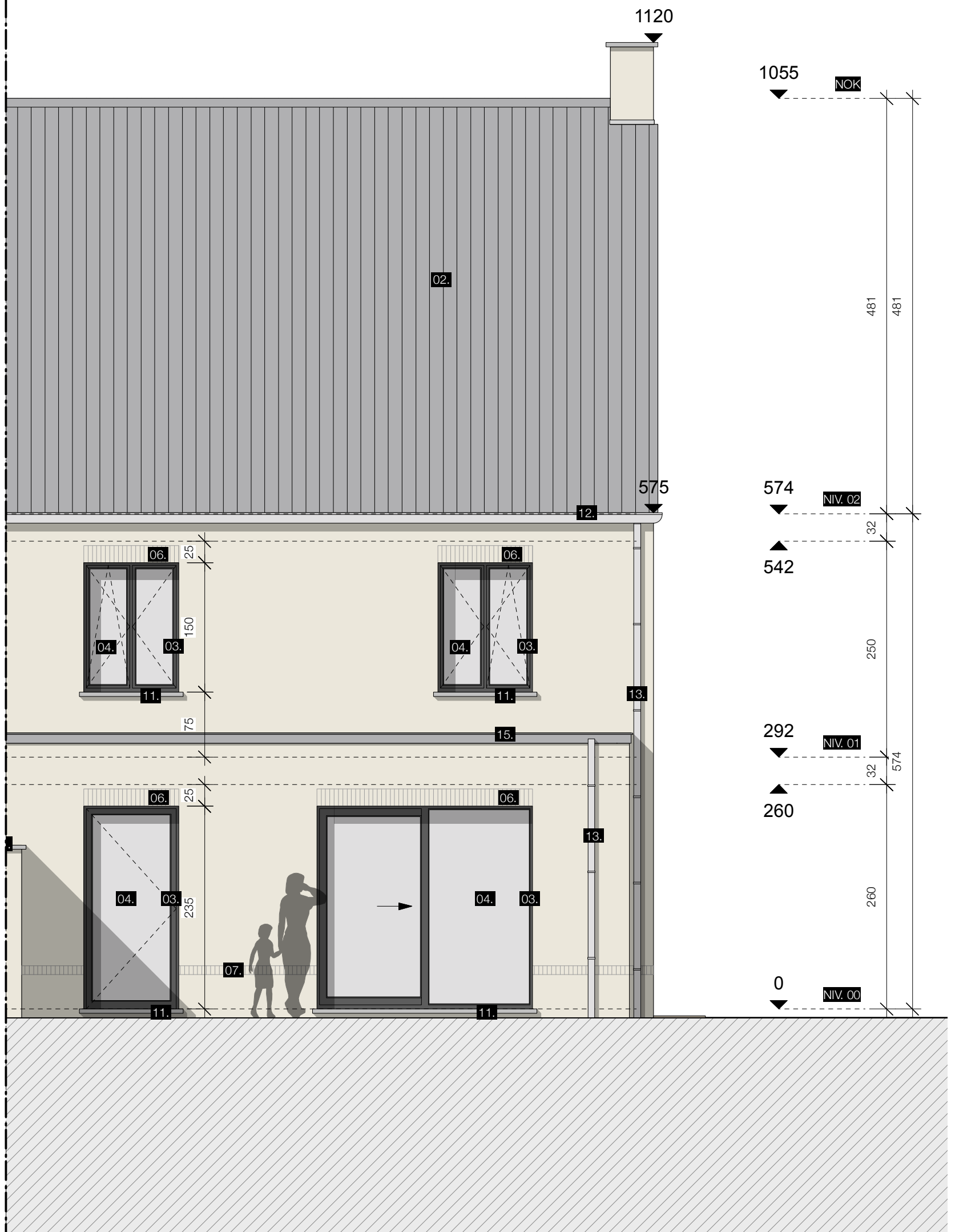

WONING LOT 1

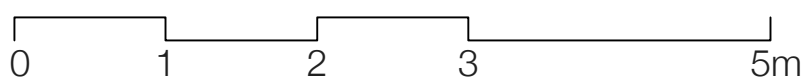

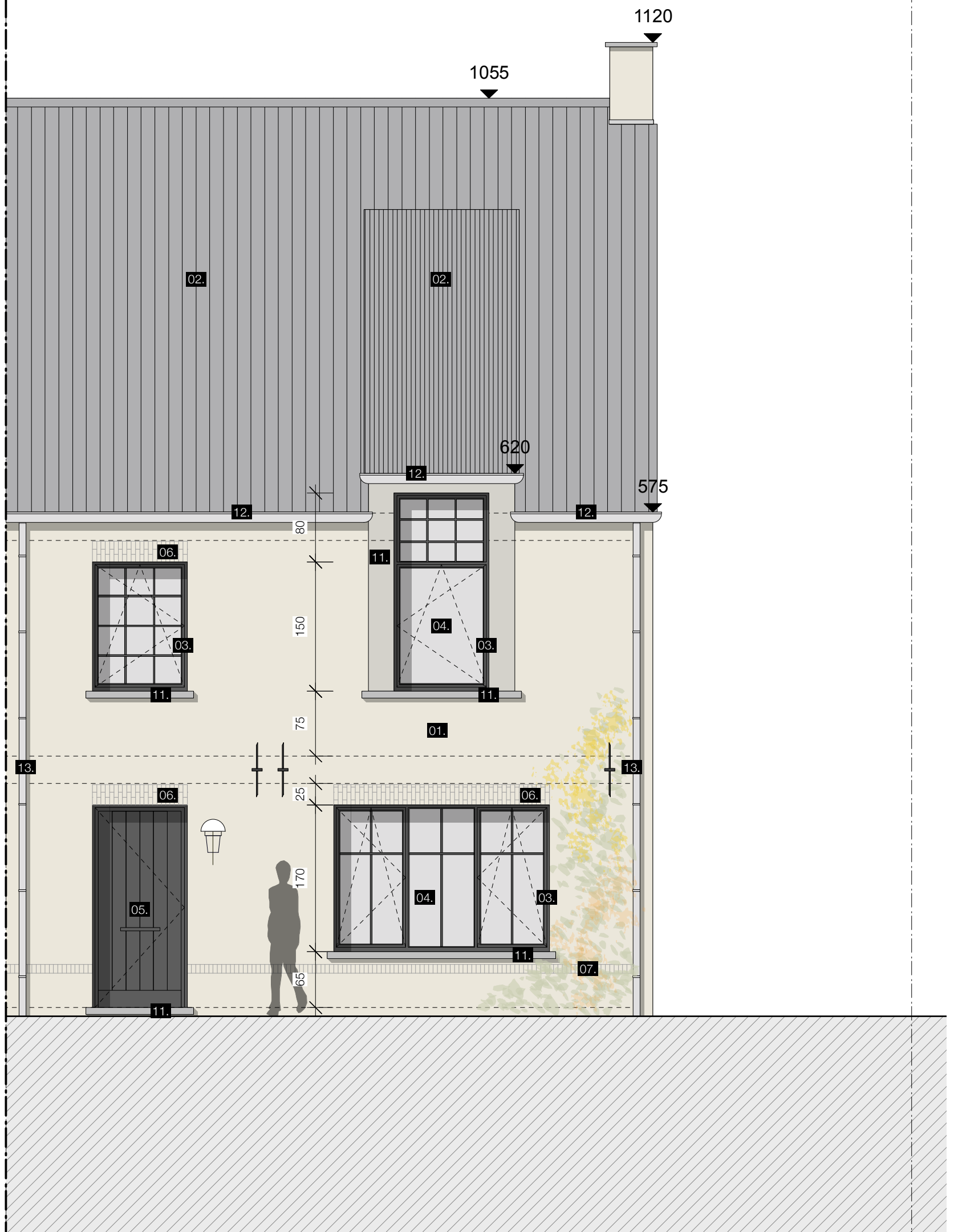

WONING LOT 2

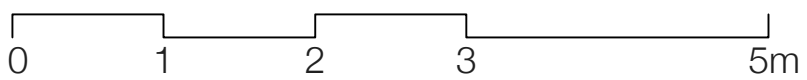

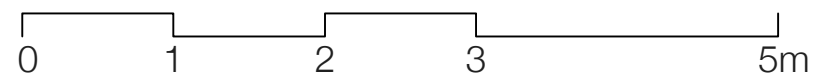
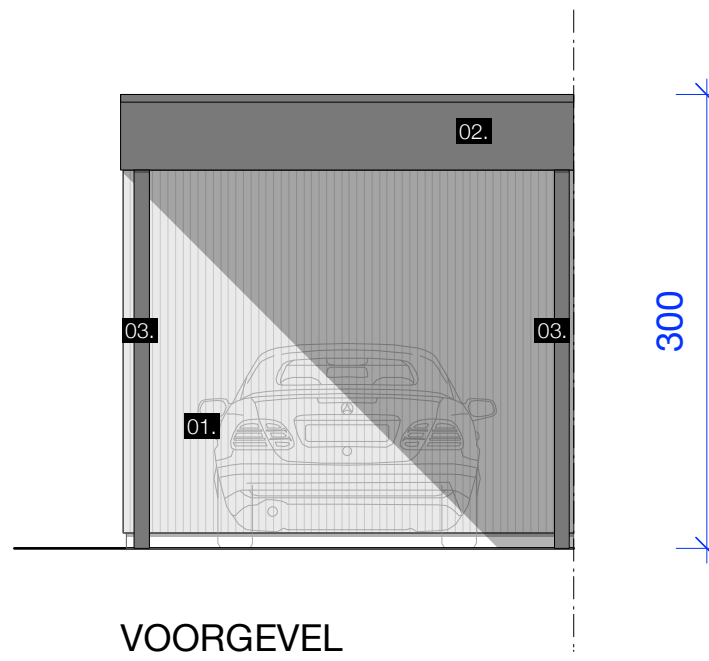

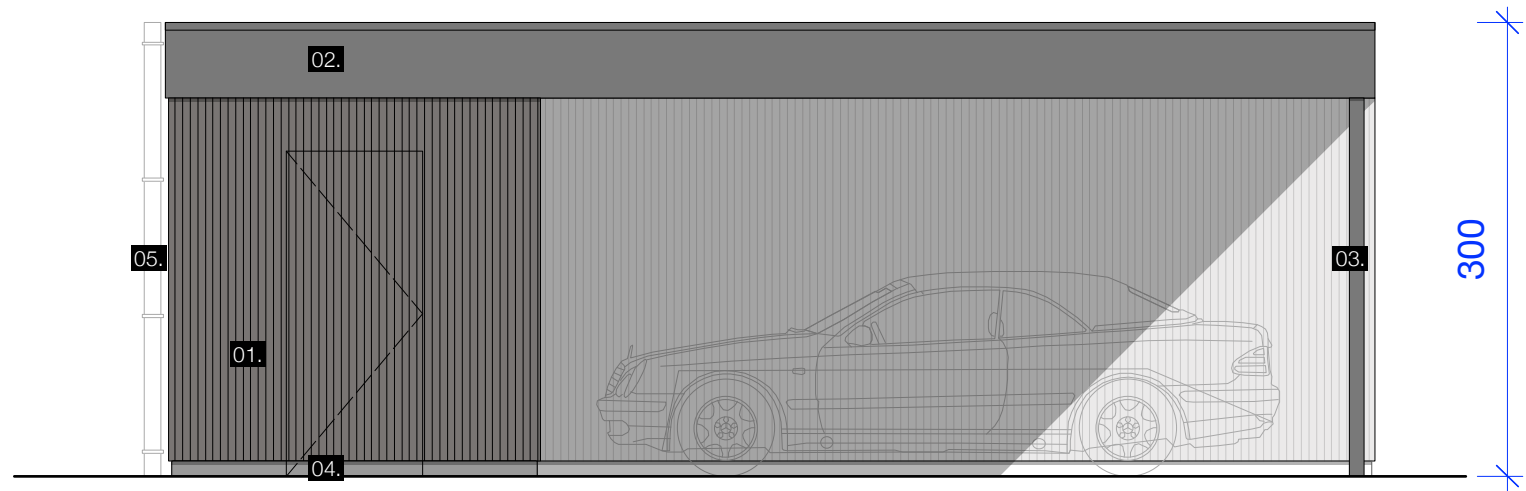

ZIJGEVEL

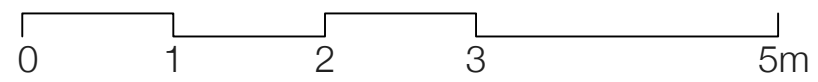

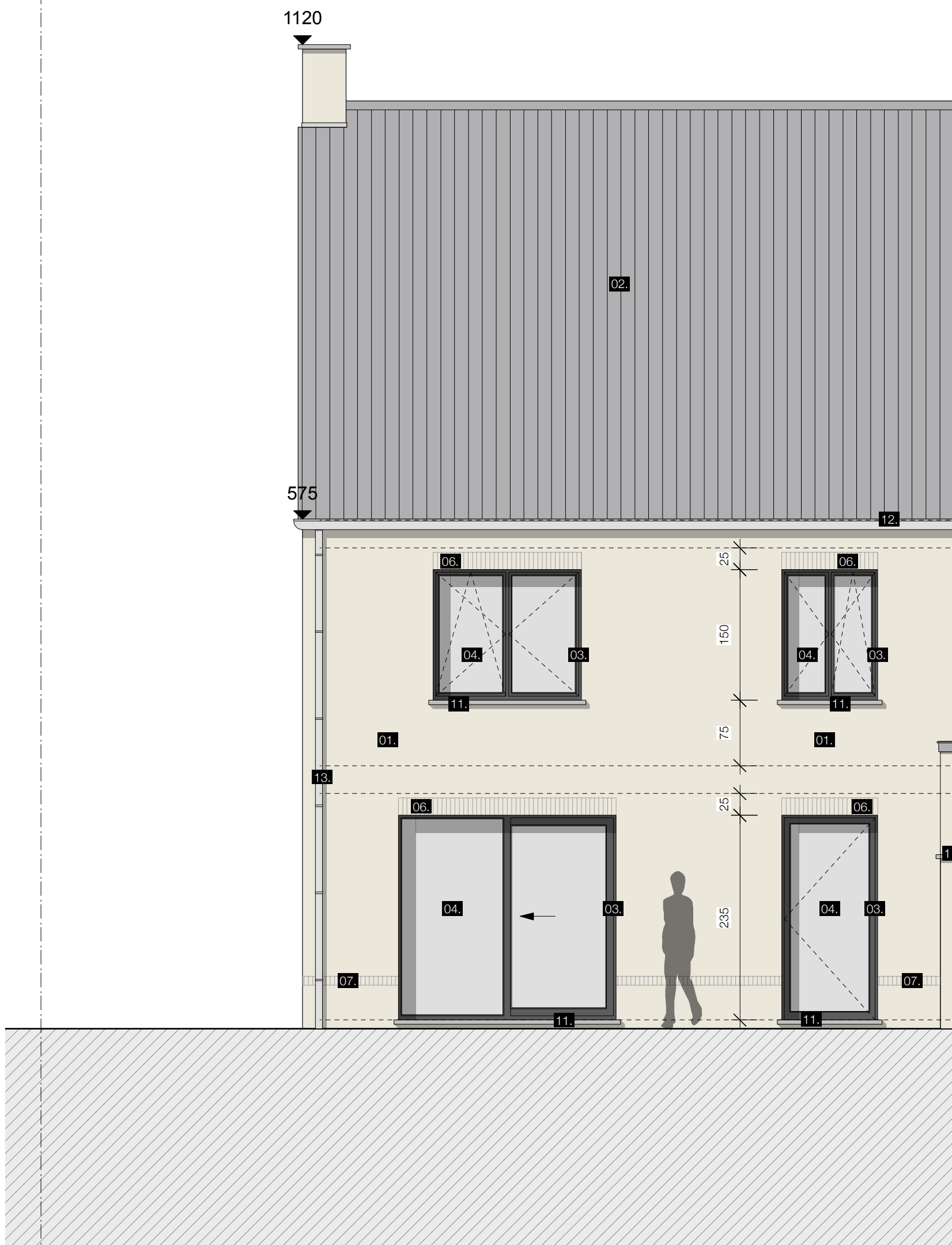

WONING LOT 2

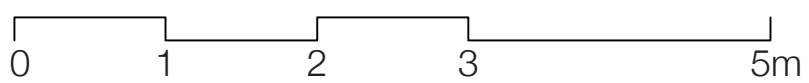

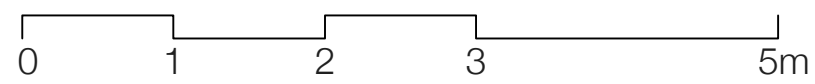
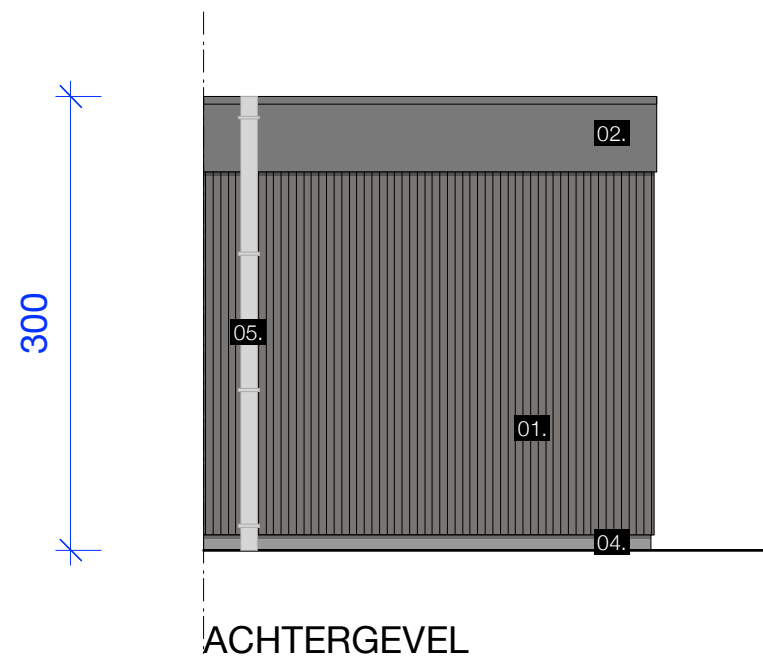

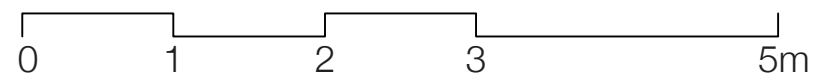
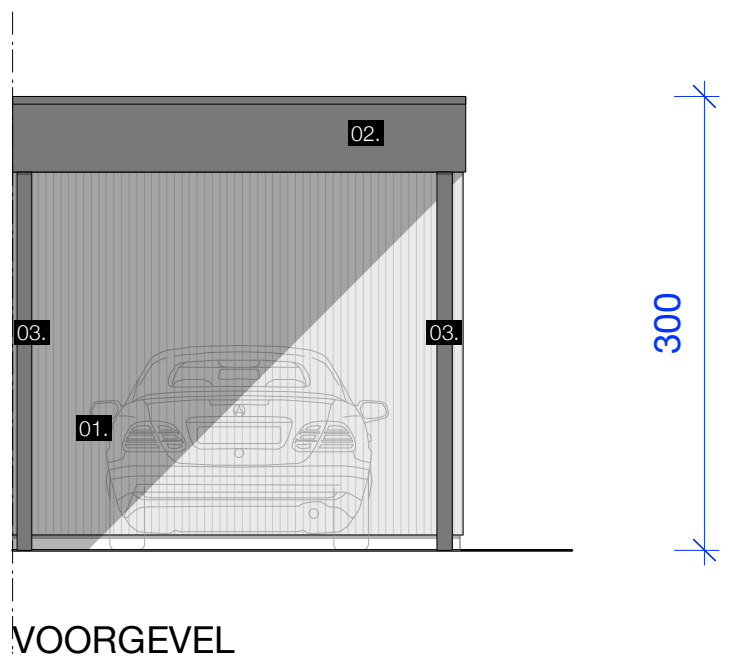



WONING LOT 3

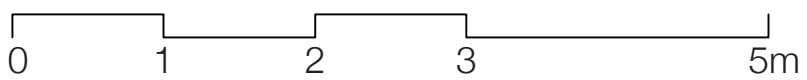



WONING LOT 4

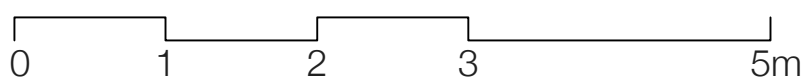

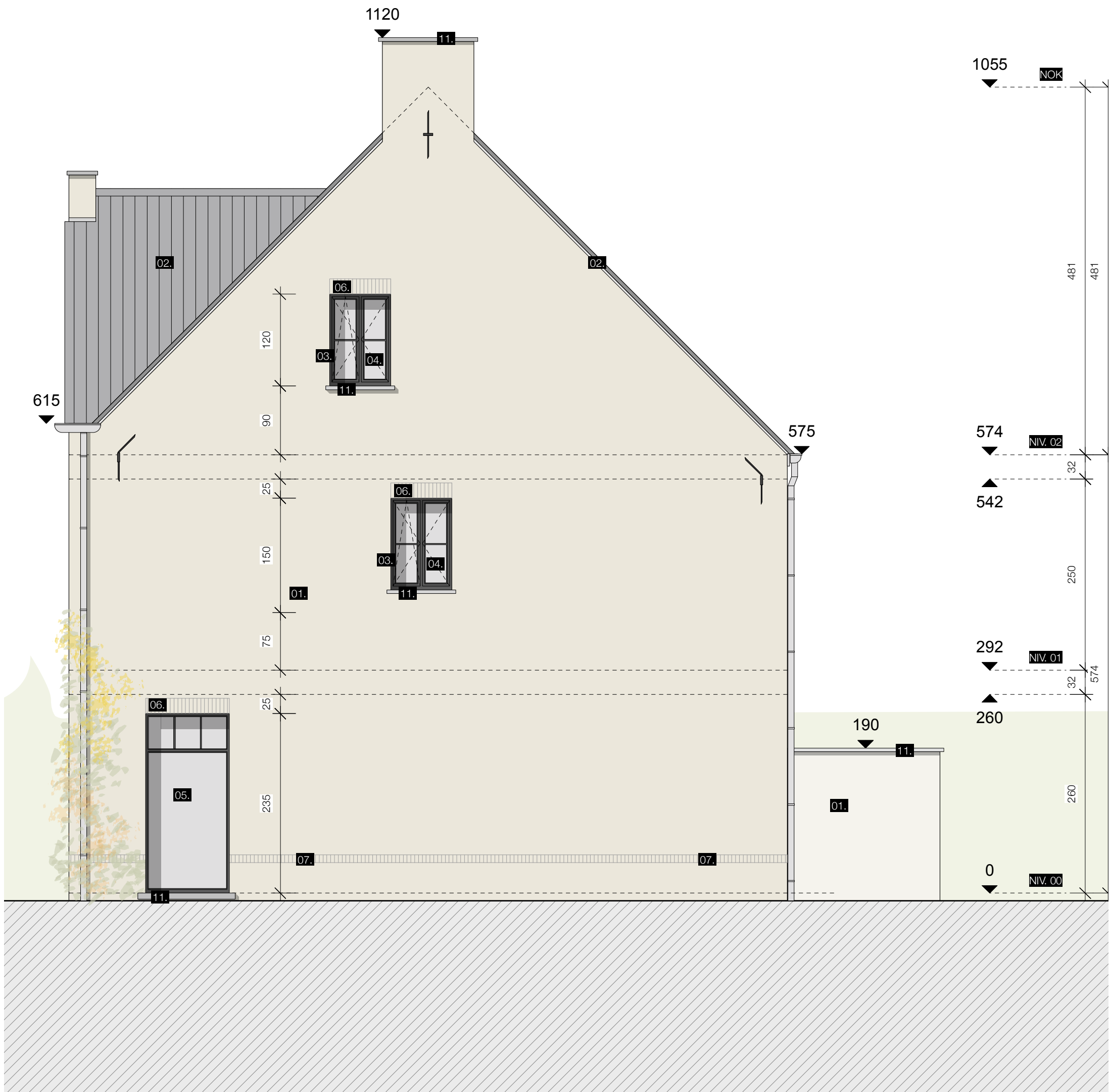

WONING LOT 4

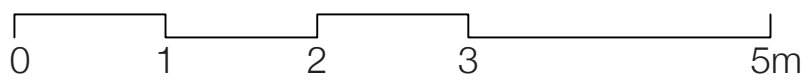

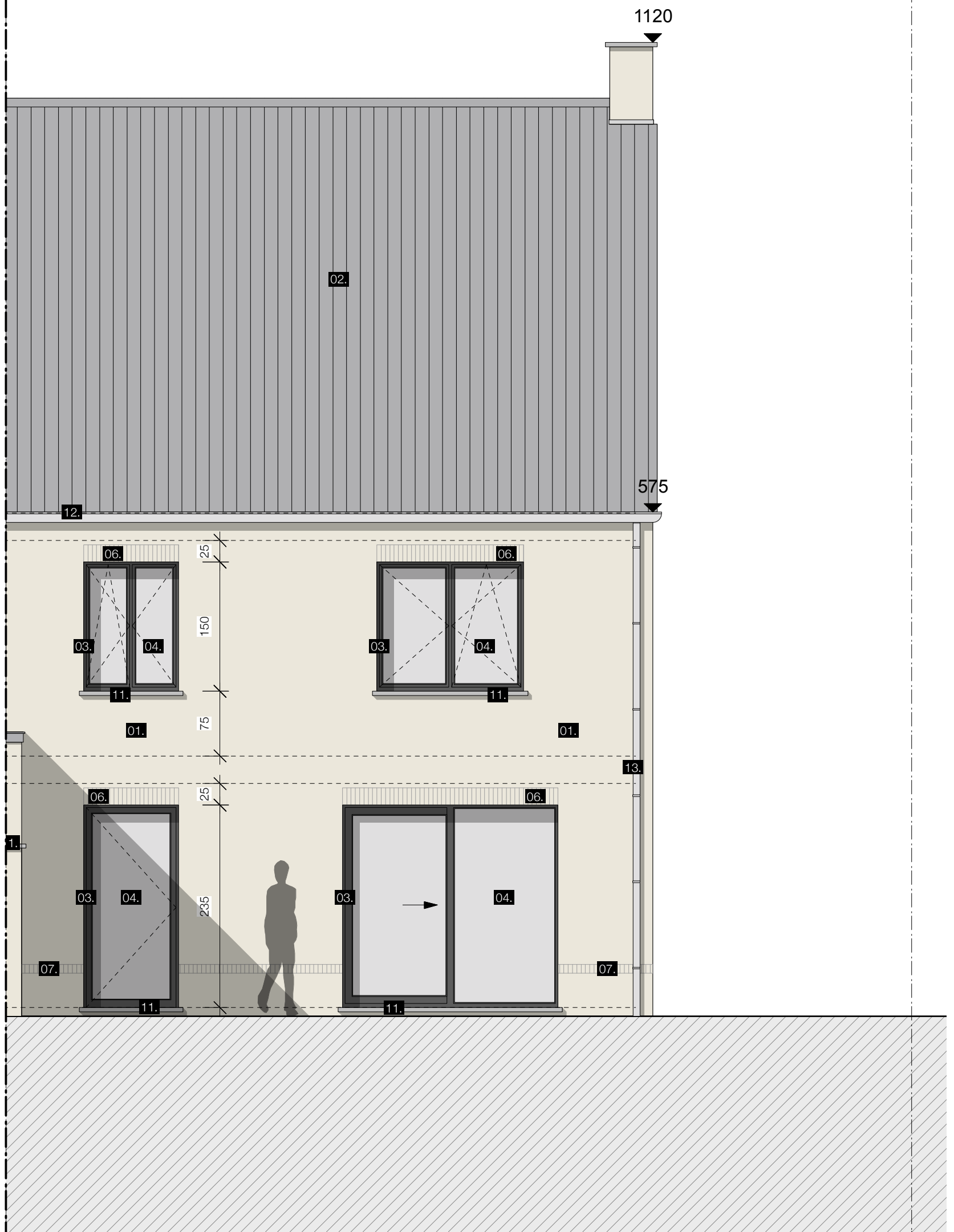

WONING LOT 5

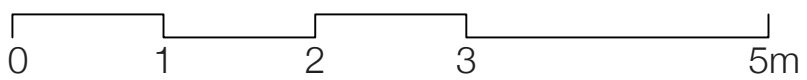

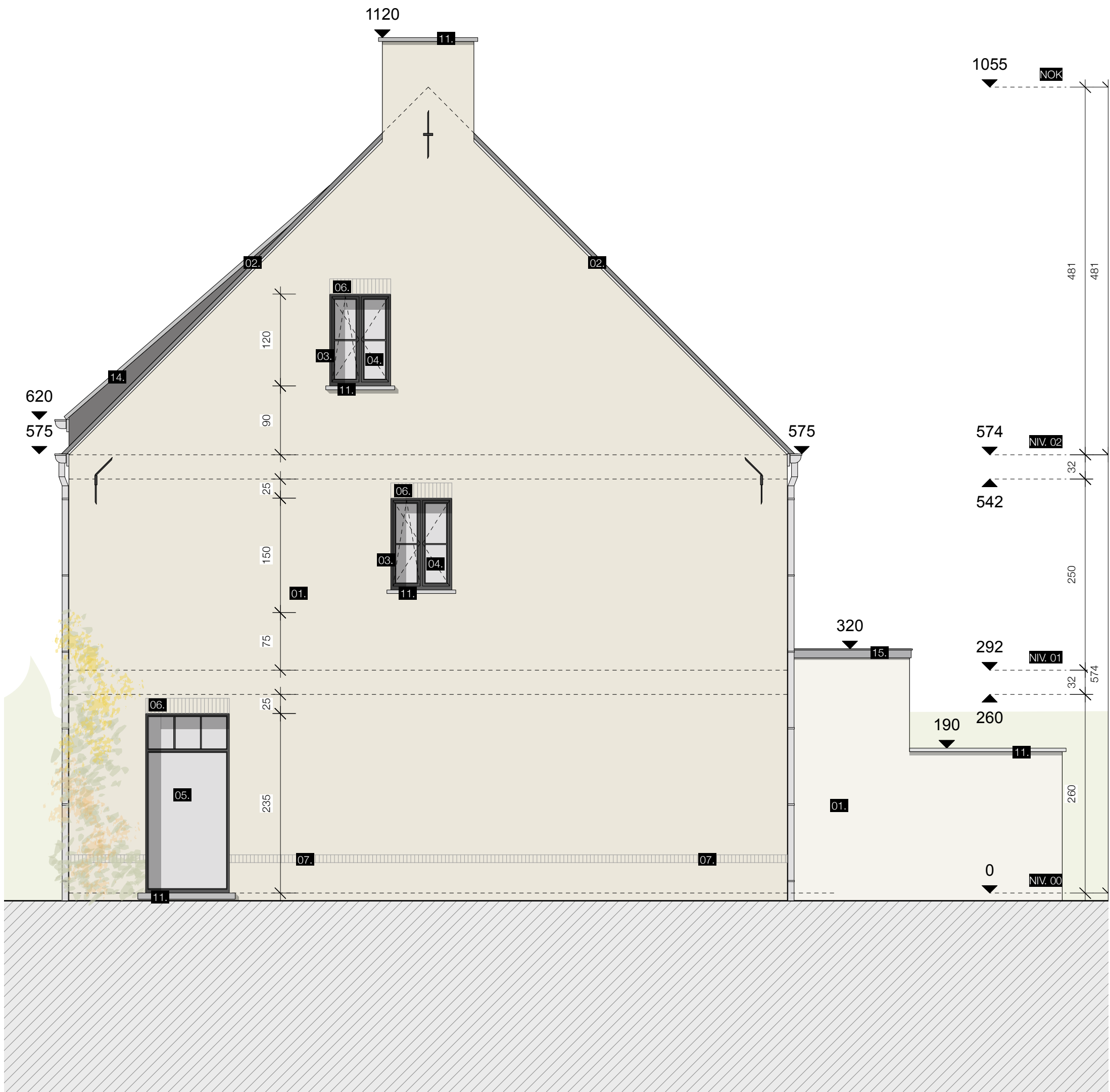

WONING LOT 2

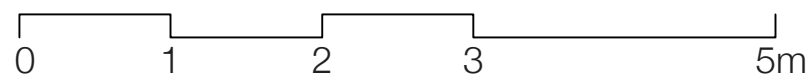

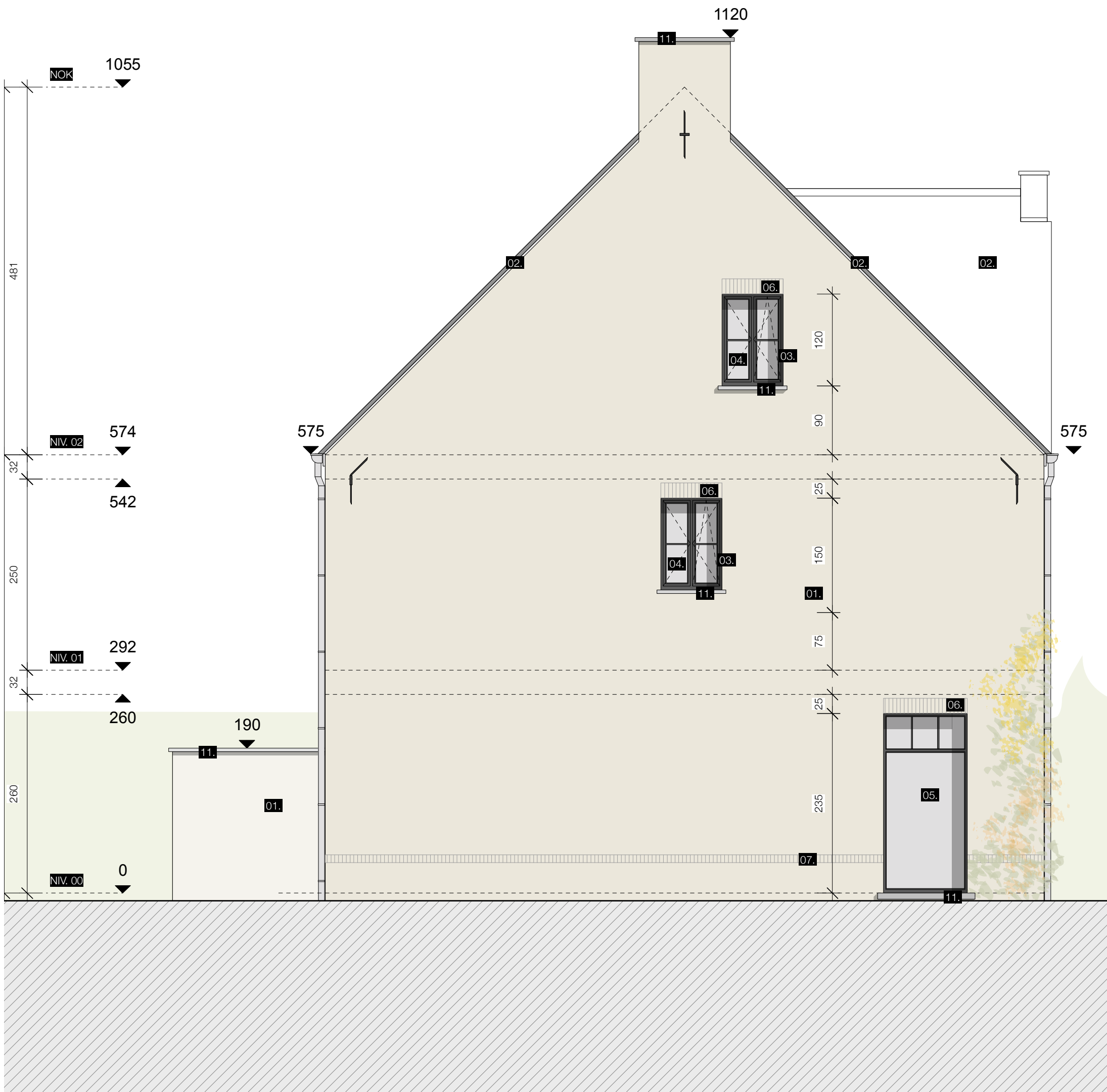

WONING LOT 3

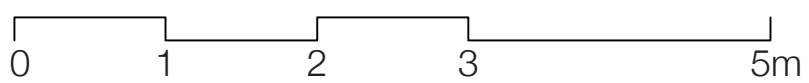

LAURIJSENS ARCHITECTS

lot 3 ZIJGEVEL
SCHAAL 1/50

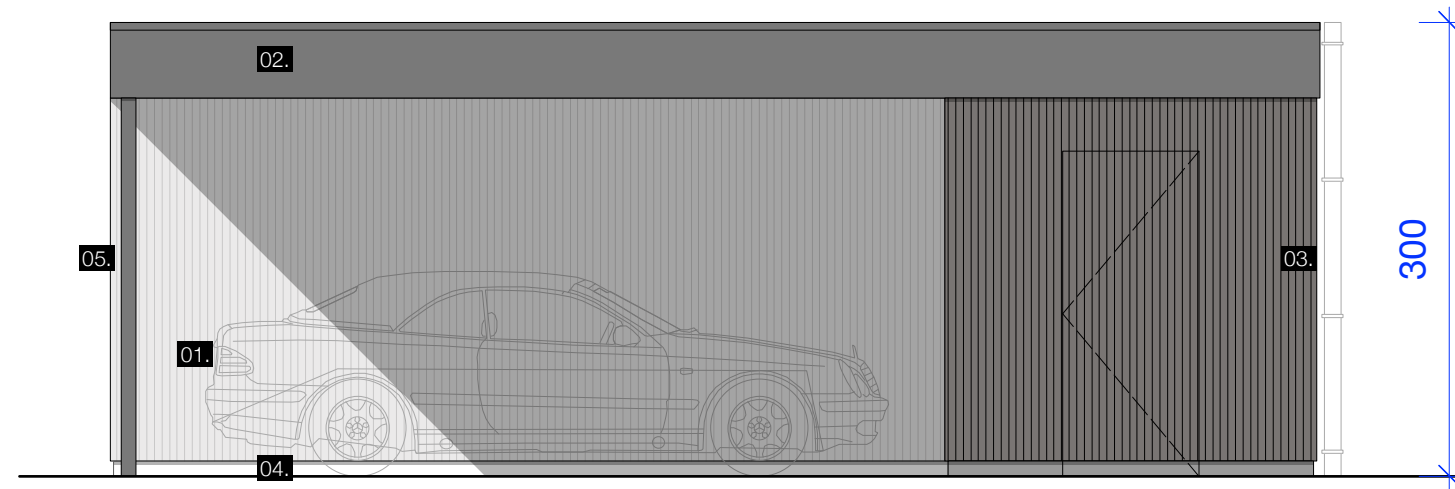

ZIJGEVEL

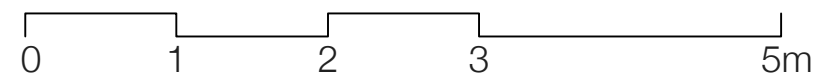

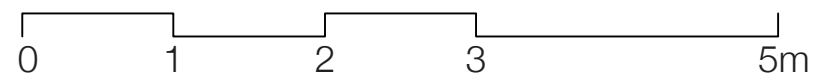
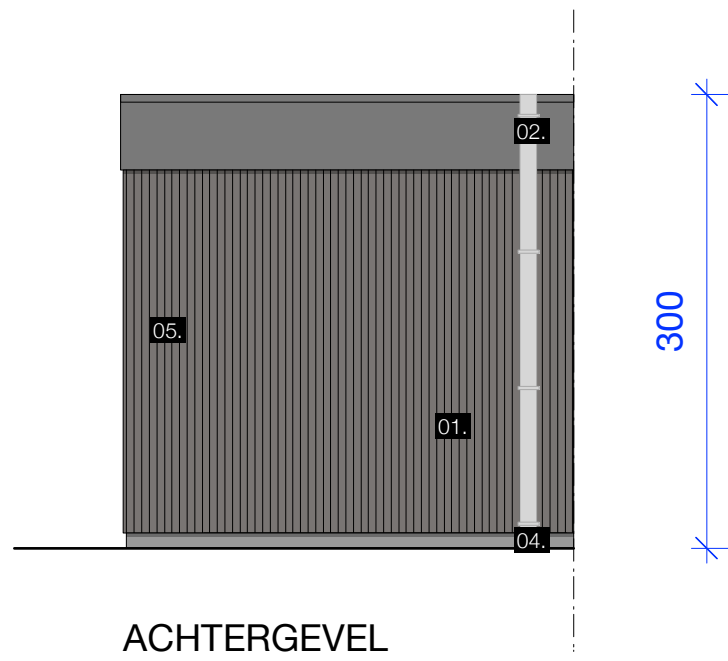

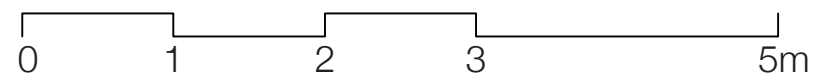
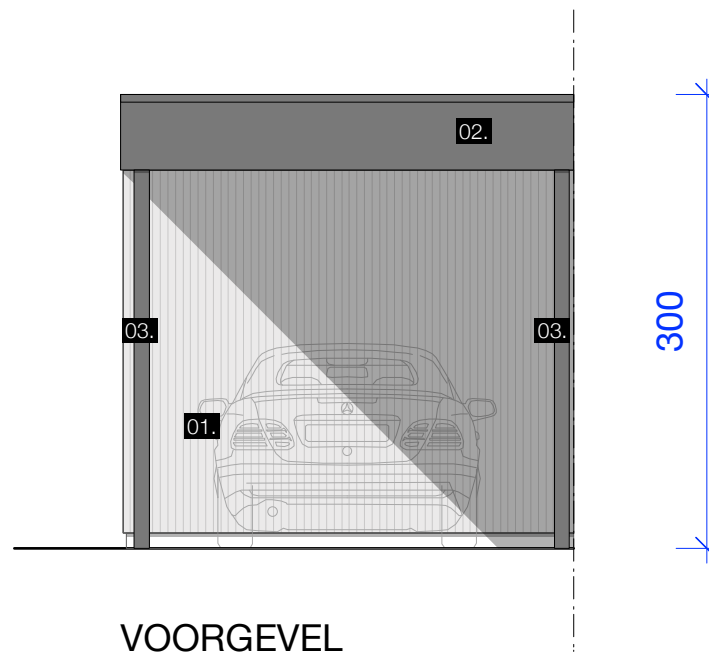

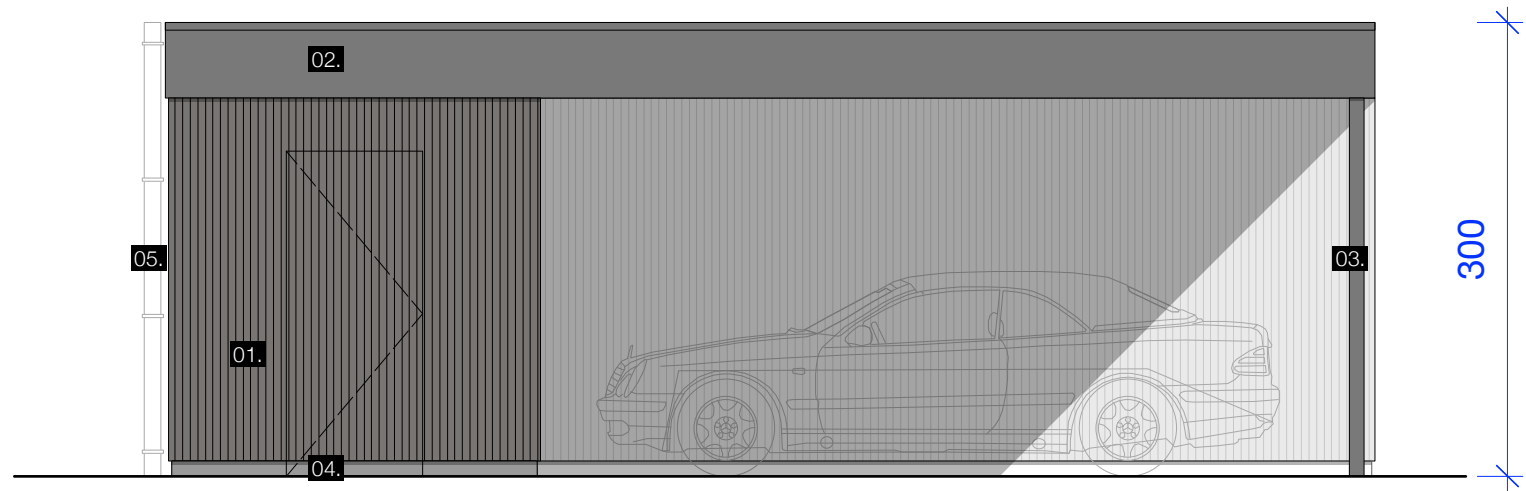

ZIJGEVEL

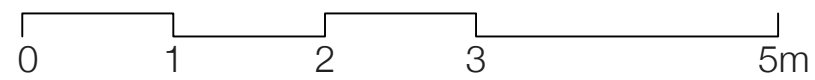



WONING LOT 4

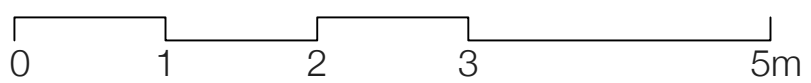

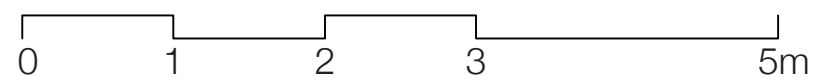
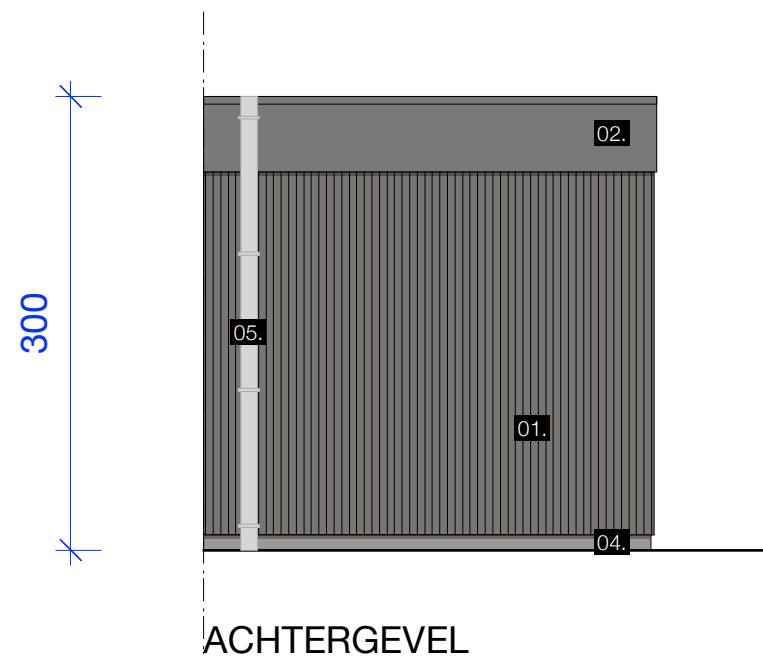



WONING LOT 5

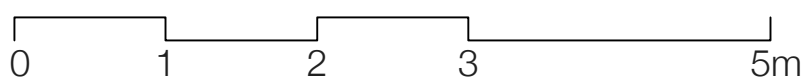

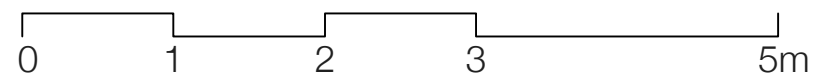
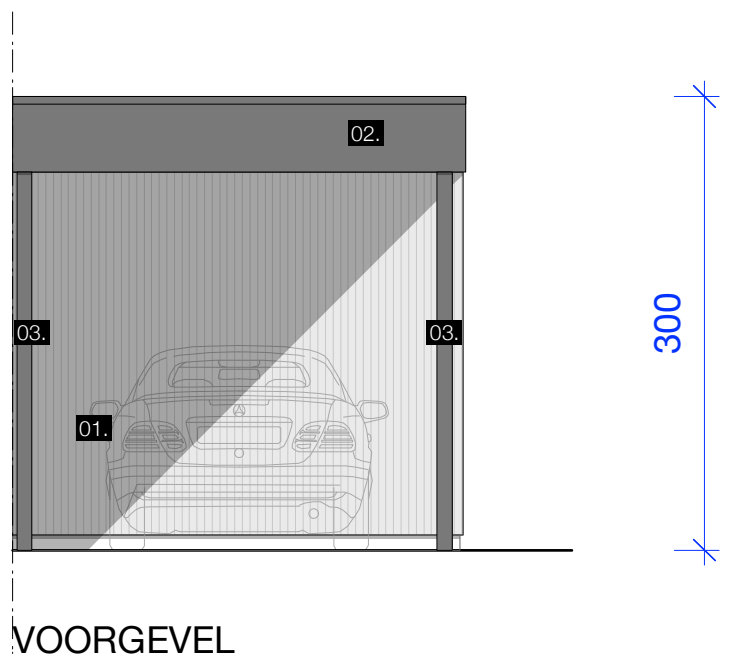

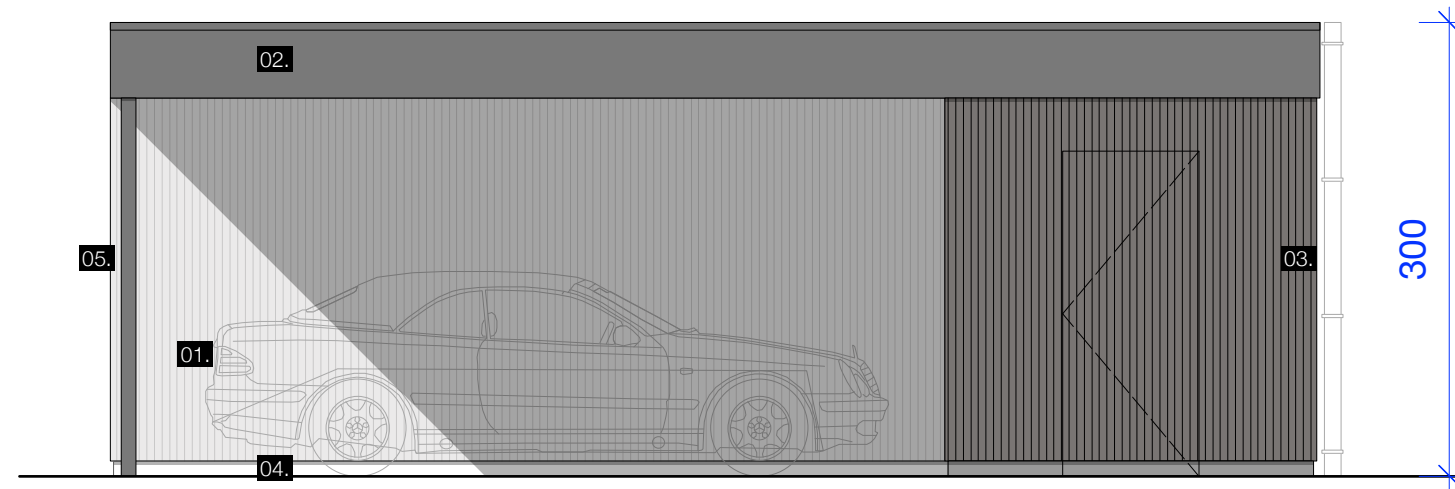

ZIJGEVEL

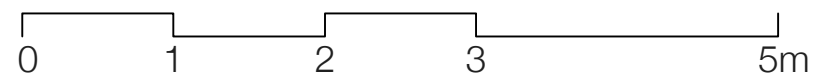

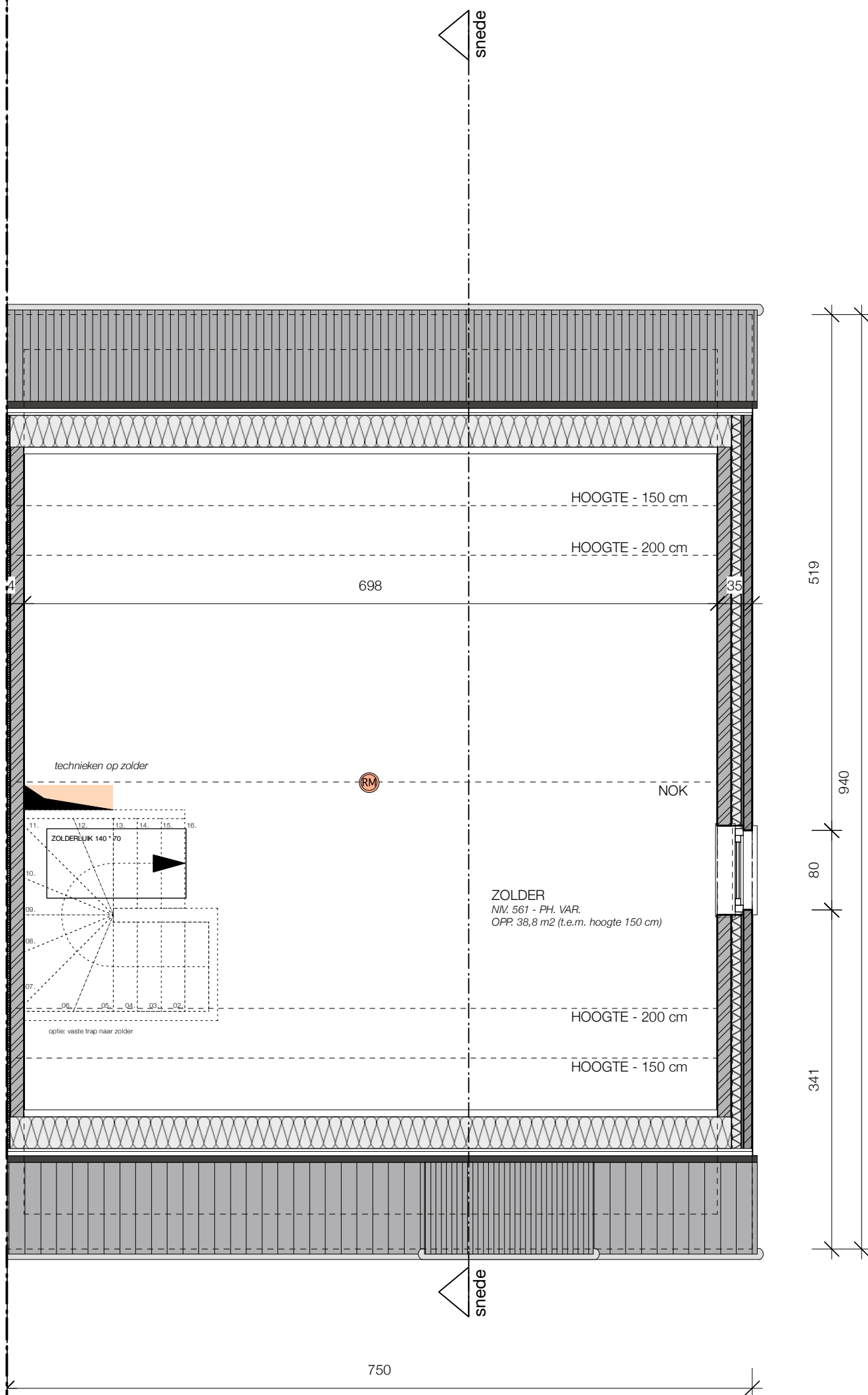

WONING LOT 2

OPP. 141 m²
(70,5 + 70,5) (EXCL. ZOLDER)

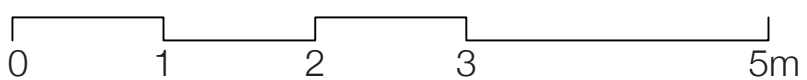
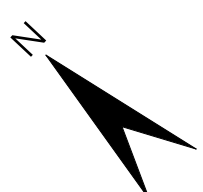

LAURIJSENS ARCHITECTS

lot 2 ZOLDER
SCHAAL 1/50

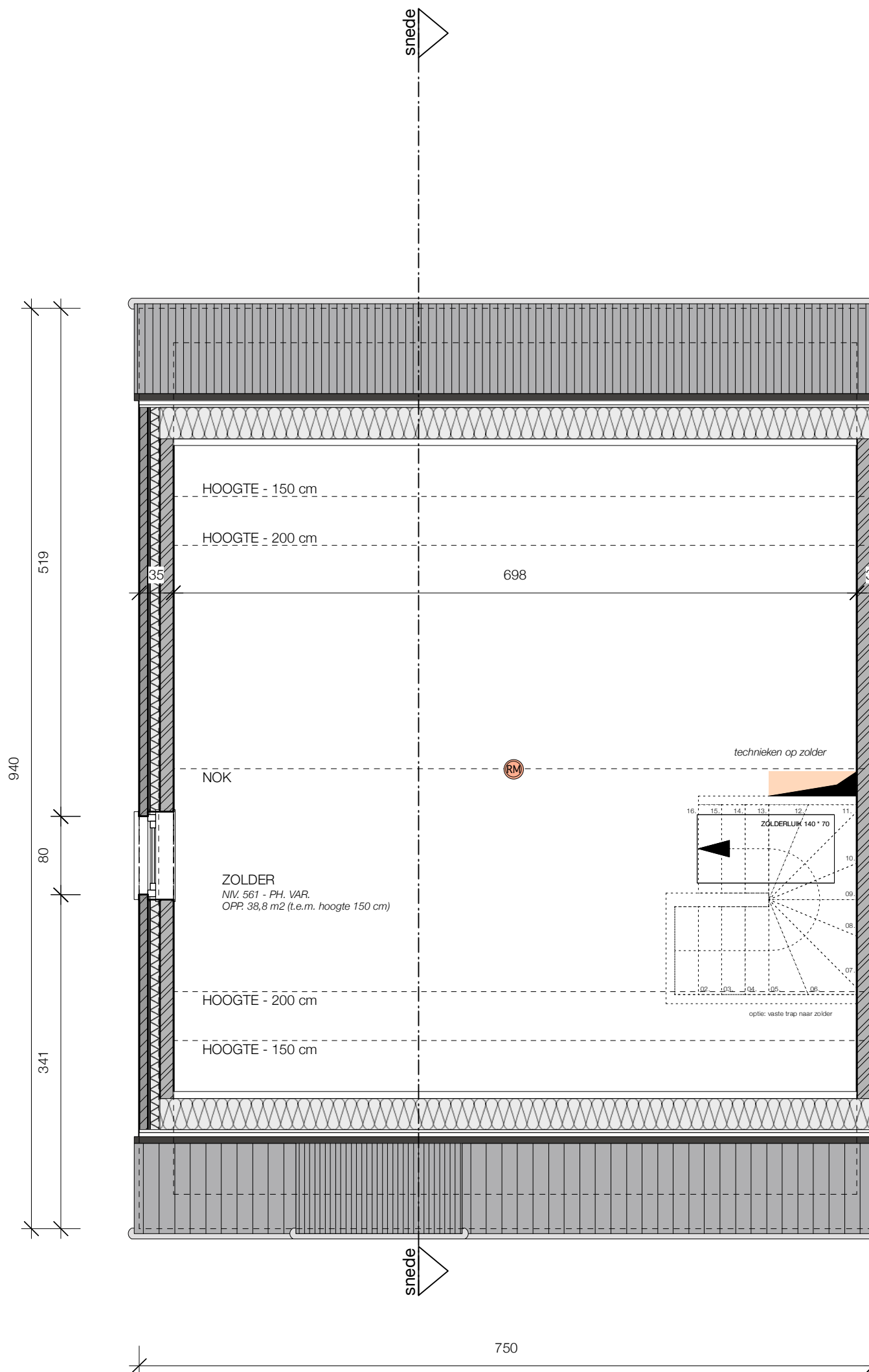

WONING LOT 3

OPP. 141 m²
 (70,5 + 70,5) (EXCL. ZOLDER)

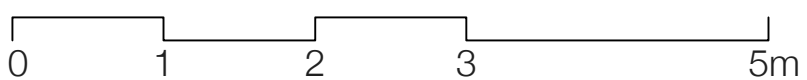
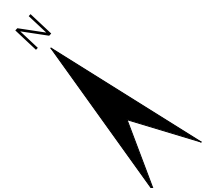

LAURIJSENS ARCHITECTS

lot 3 ZOLDER
 SCHAAL 1/50

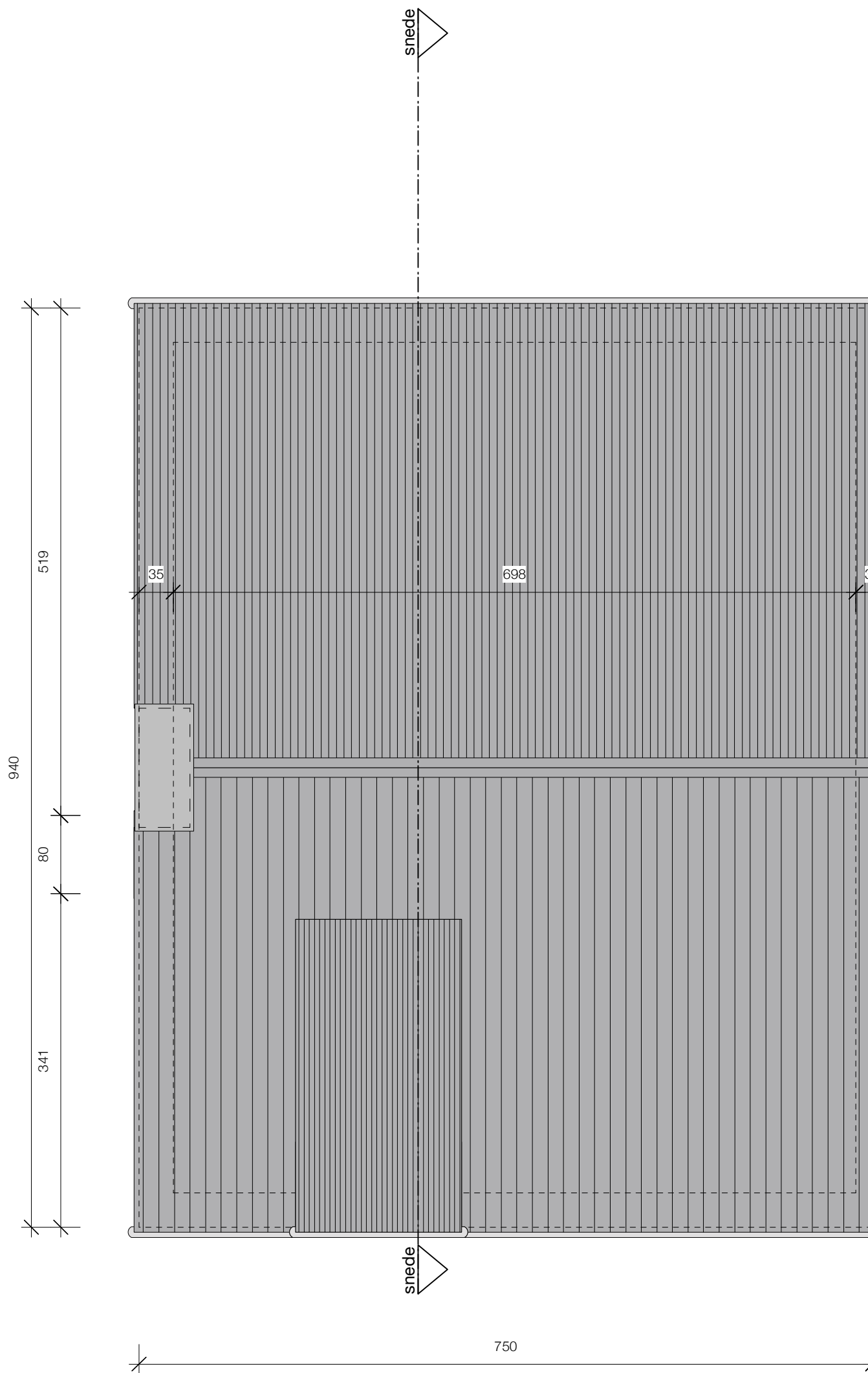

WONING LOT 3

OPP. 141 m²
 (70,5 + 70,5) (EXCL. ZOLDER)

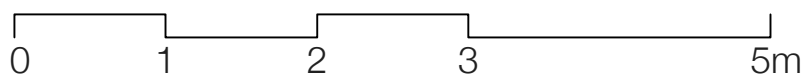
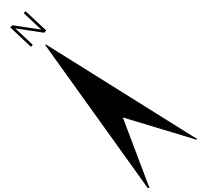



WONING LOT 5

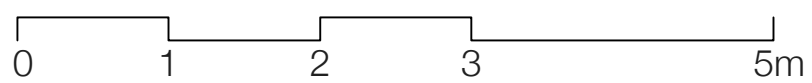

LAURIJSENS ARCHITECTS

lot 5 ZIJGEVEL
SCHAAL 1/50

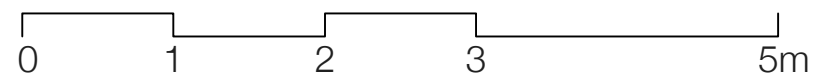
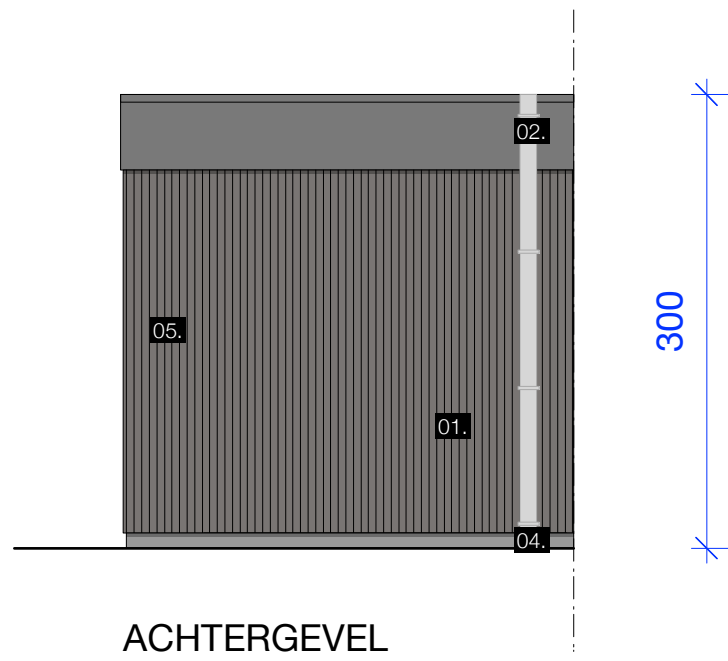



WONING LOT 6

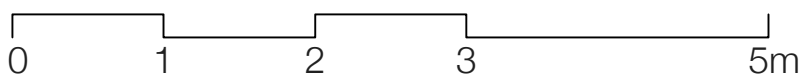



WONING LOT 6

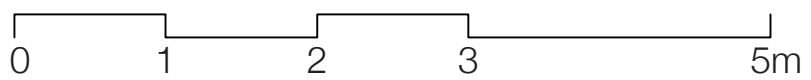

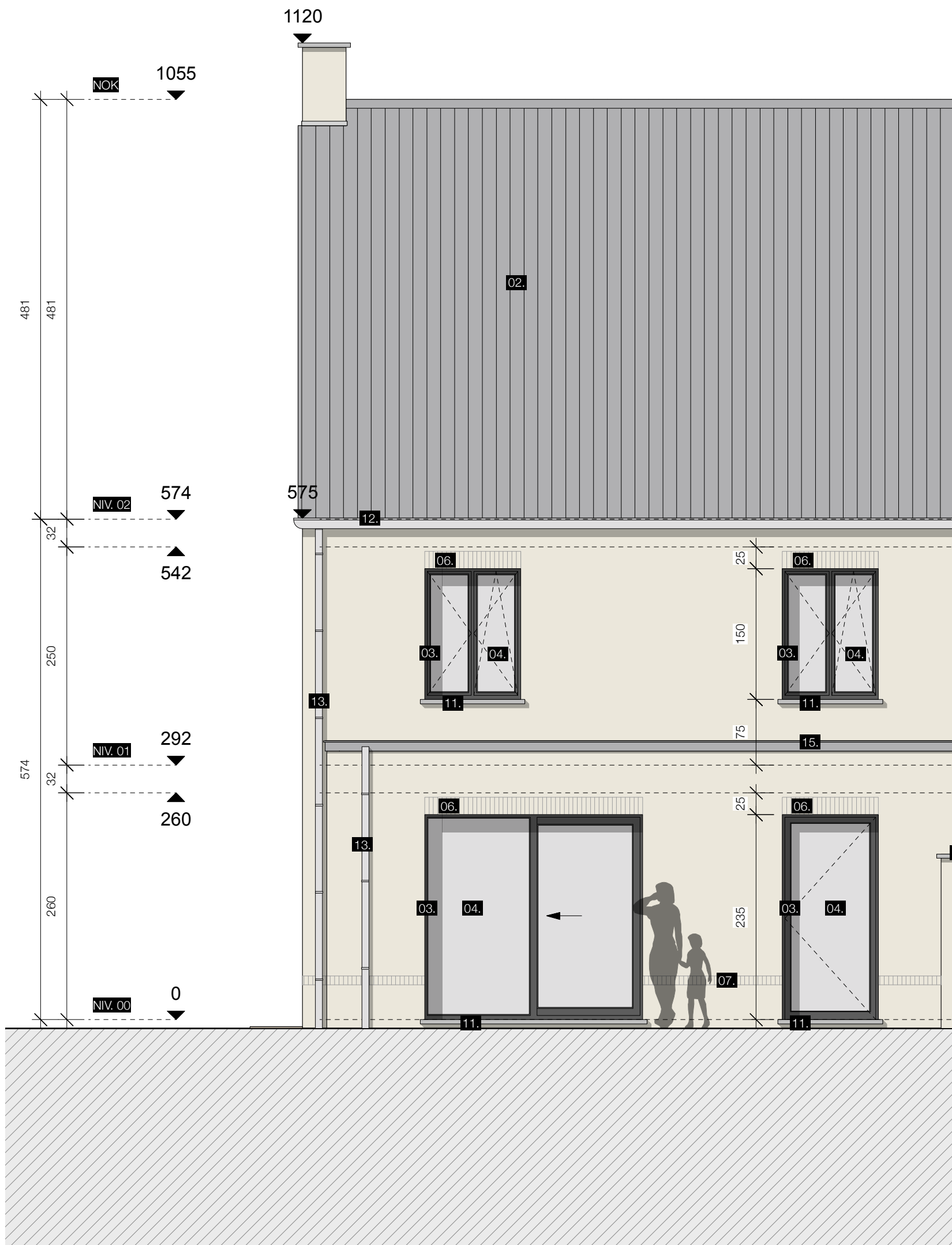

WONING LOT 6

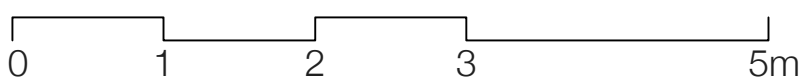

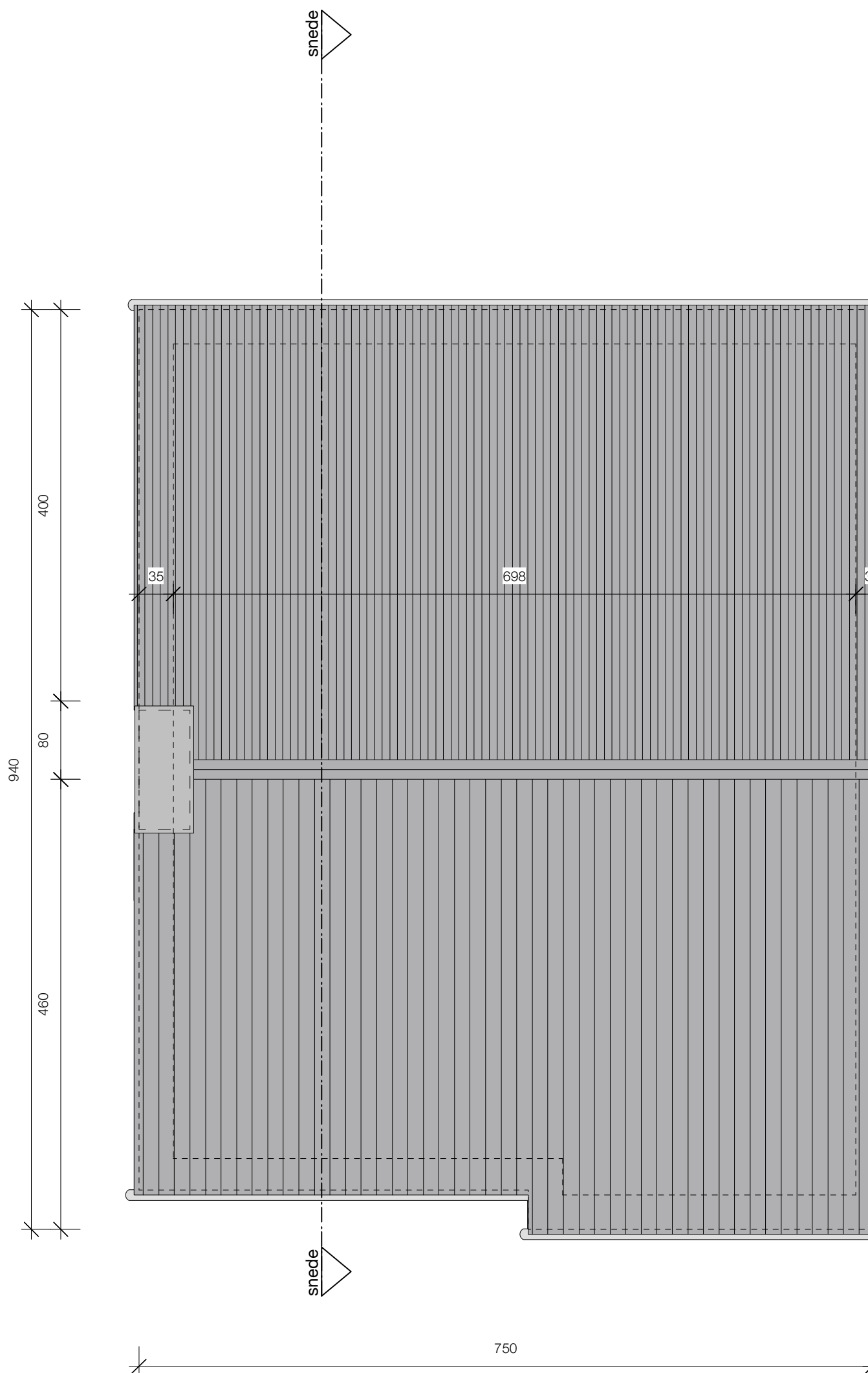

WONING LOT 1

OPP. 149 m²

(80 + 69) (EXCL. ZOLDER)

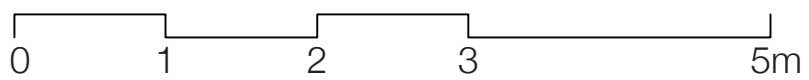
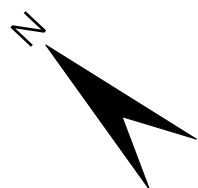

LAURIJSENS ARCHITECTS

lot 1 DAKENPLAN
SCHAAL 1/50

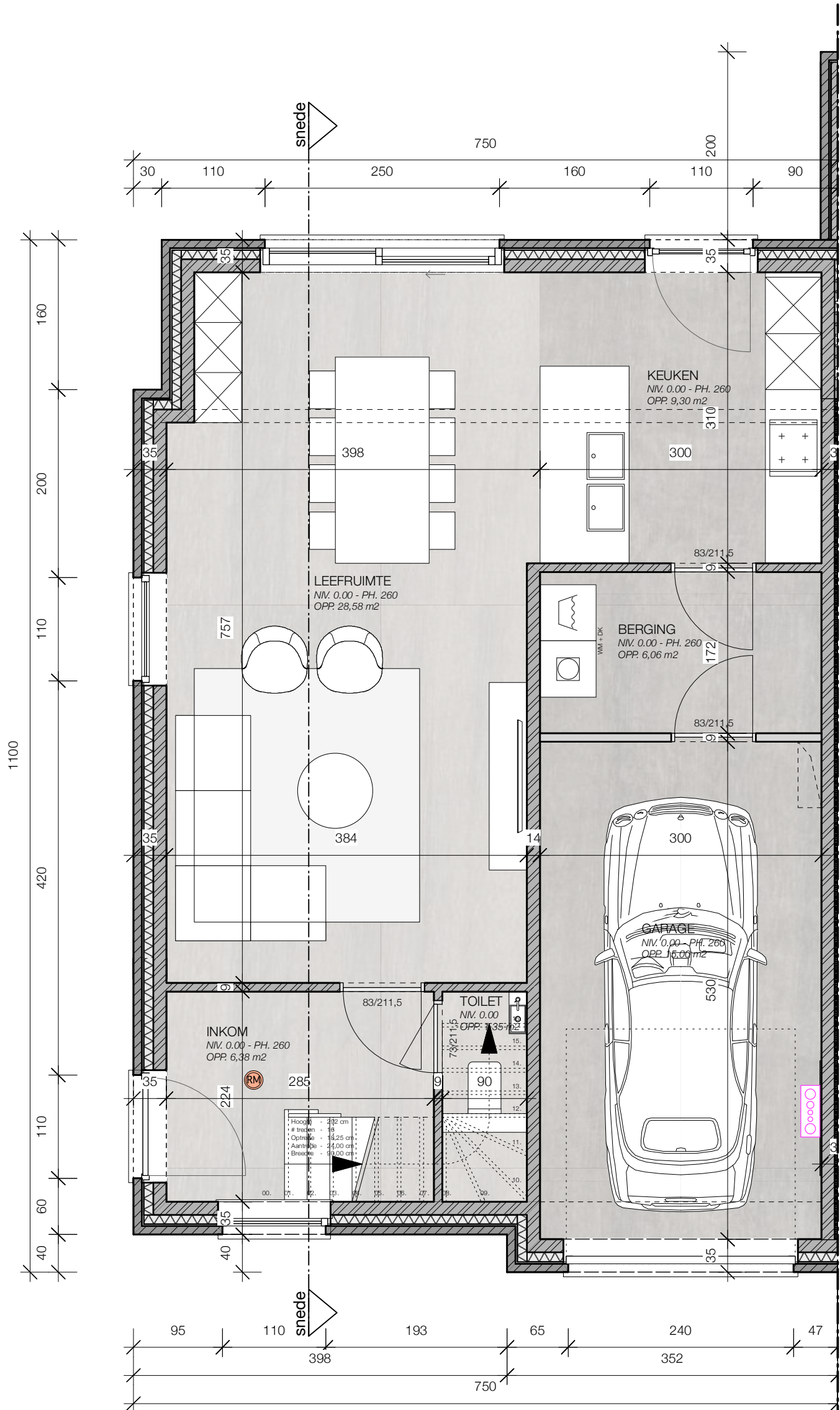

WONING LOT 1

OPP. 149 m²

(80 + 69) (EXCL. ZOLDER)

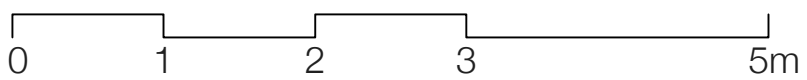
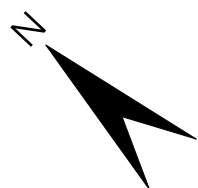

LAURIJSENS ARCHITECTS

lot 1 GELIJKVLOERS
SCHAAL 1/50

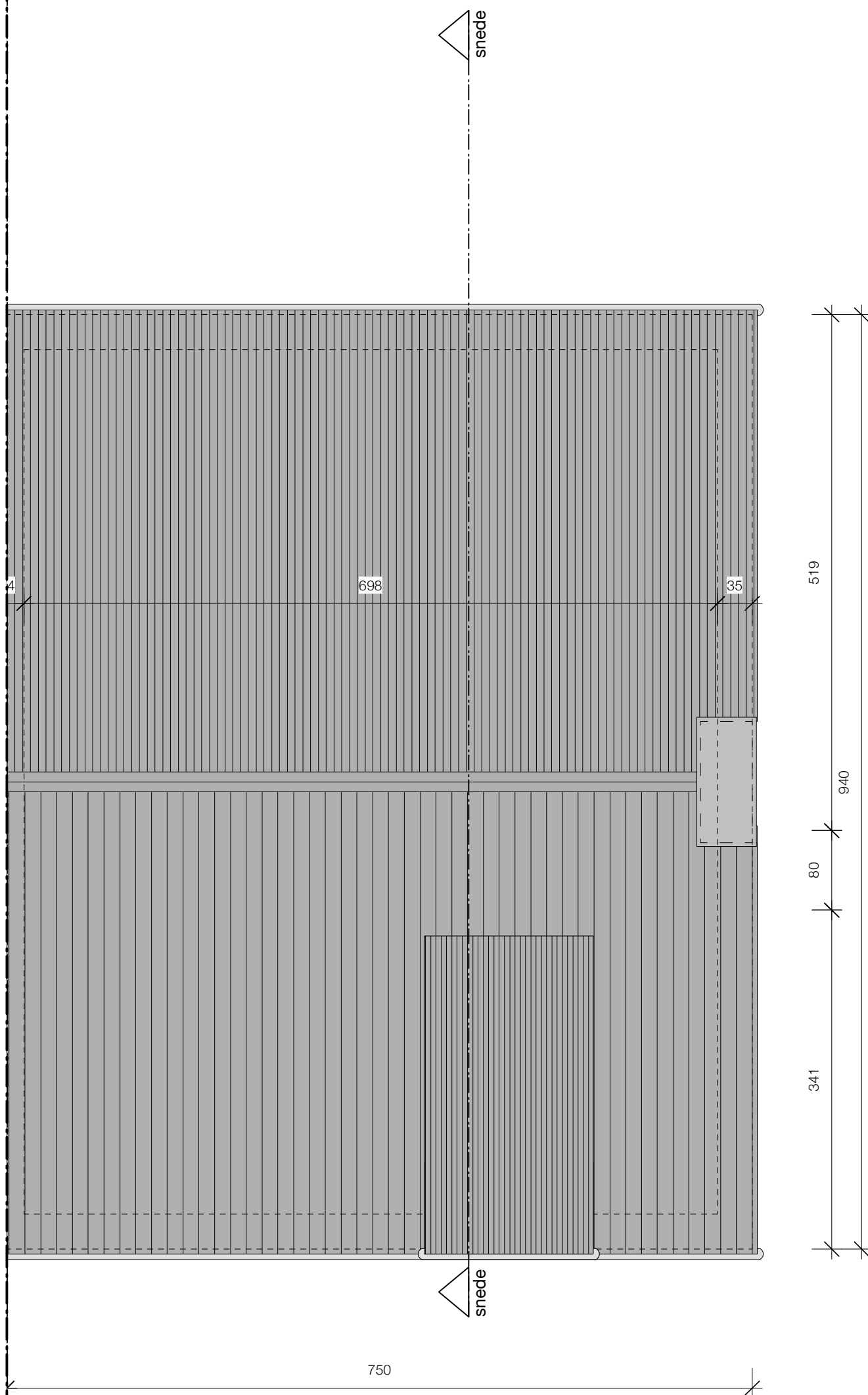

WONING LOT 2

OPP. 141 m²
 (70,5 + 70,5) (EXCL. ZOLDER)

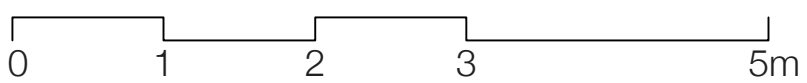
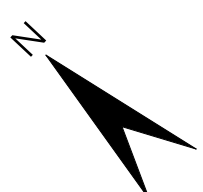

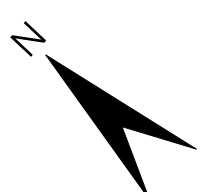
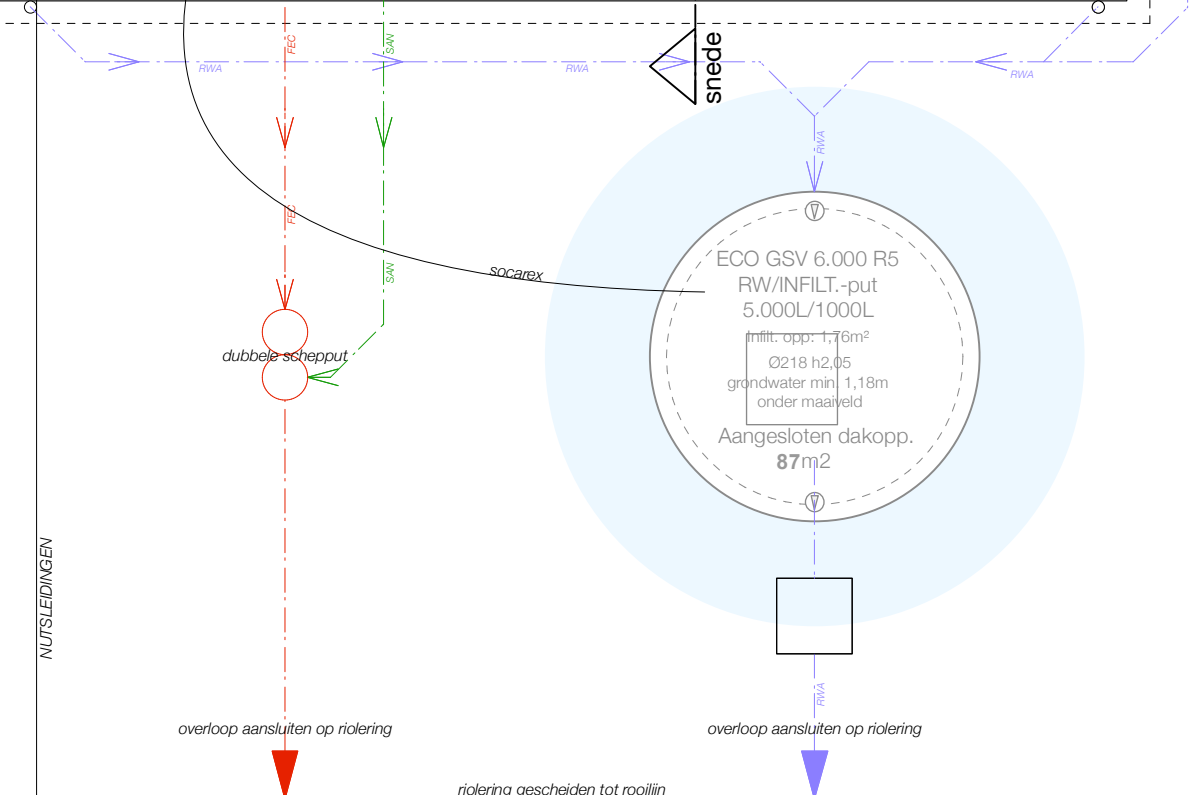
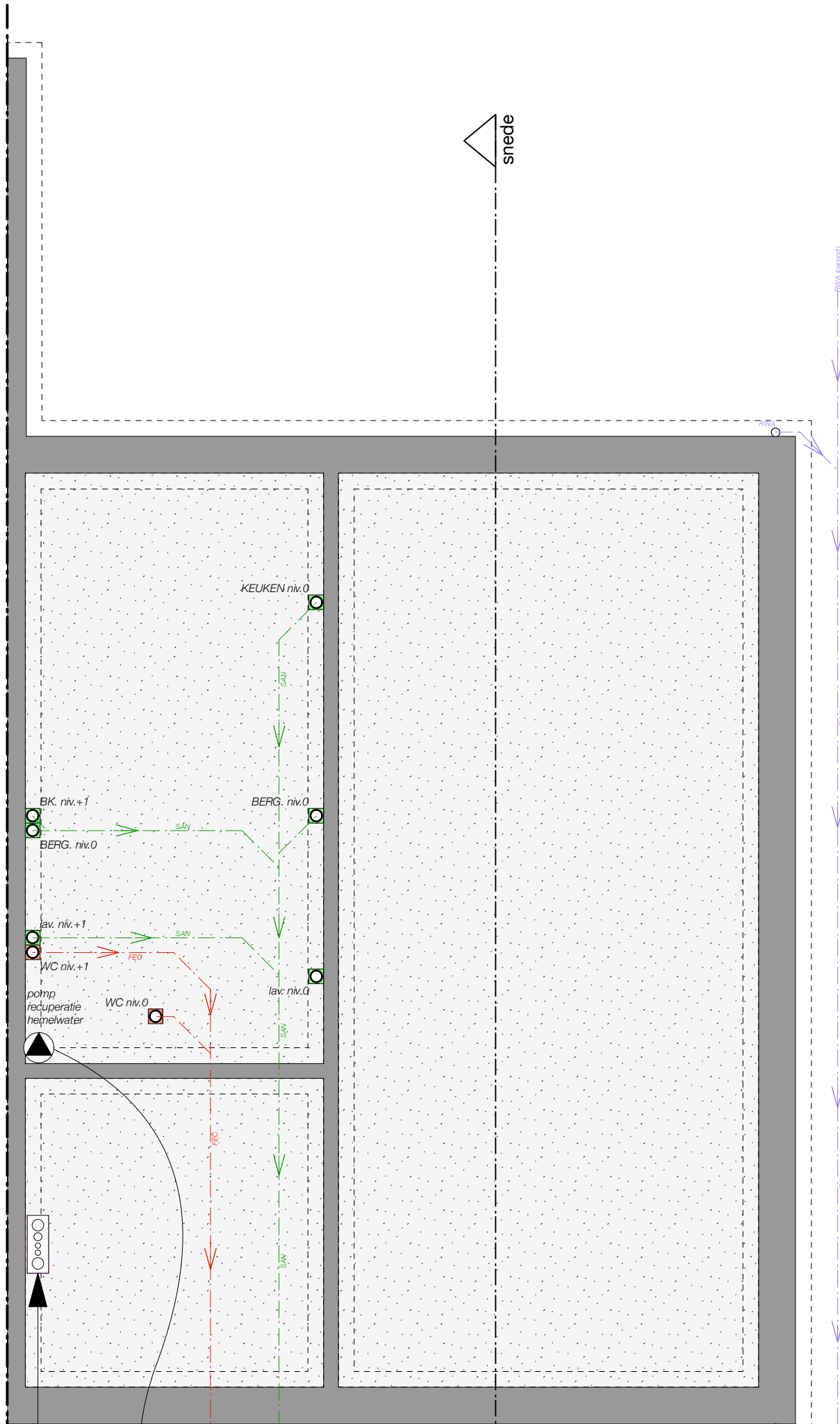

WONING LOT 2

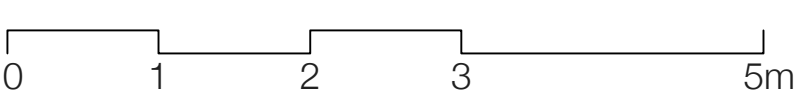

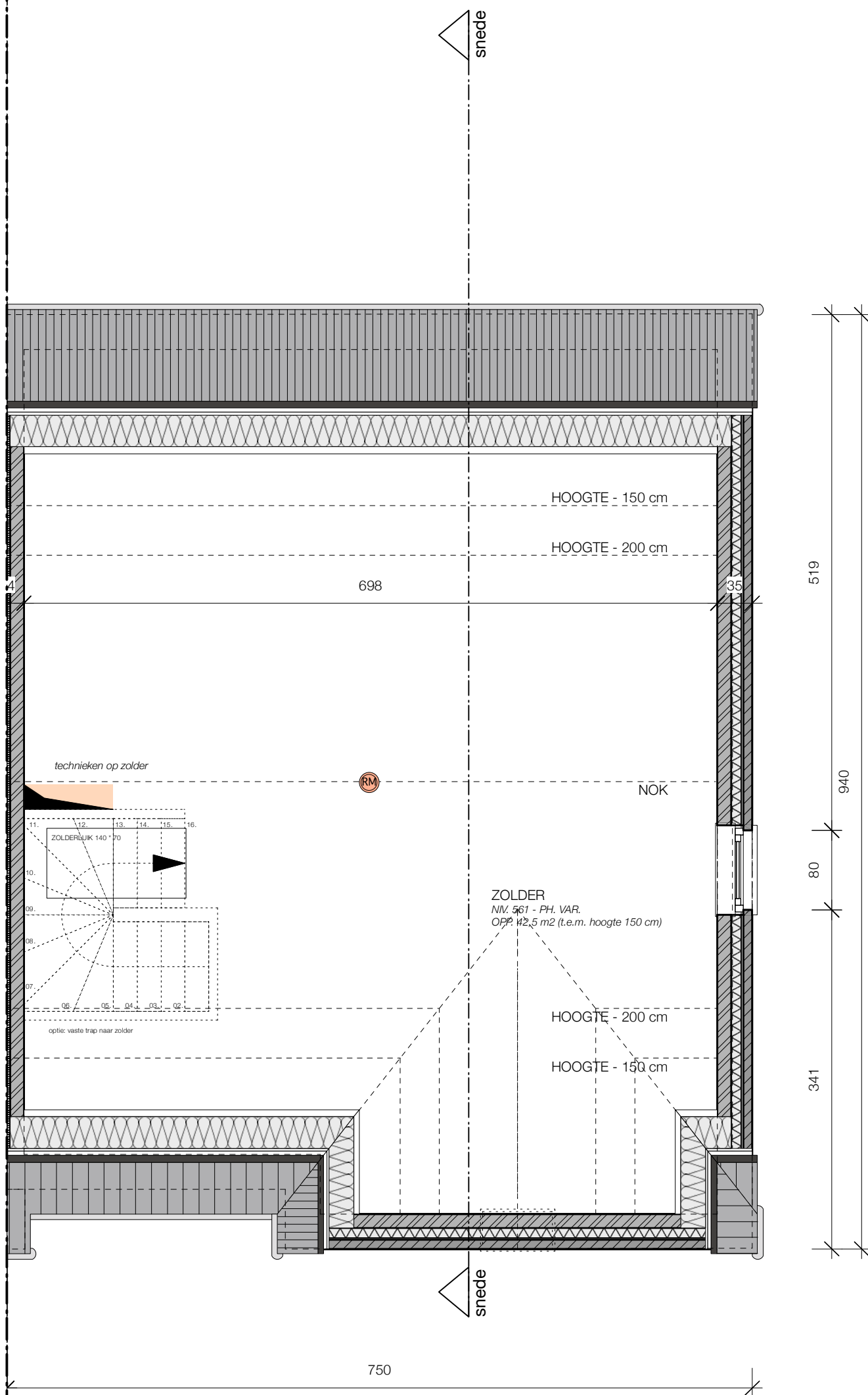

WONING LOT 4

OPP. 139 m²
 (69,5 + 69,5) (EXCL. ZOLDER)

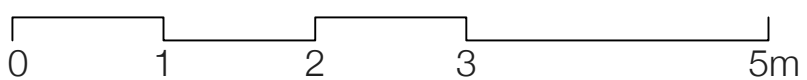
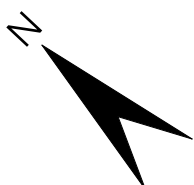

LAURIJSENS ARCHITECTS

lot 4 ZOLDER
 SCHAAL 1/50

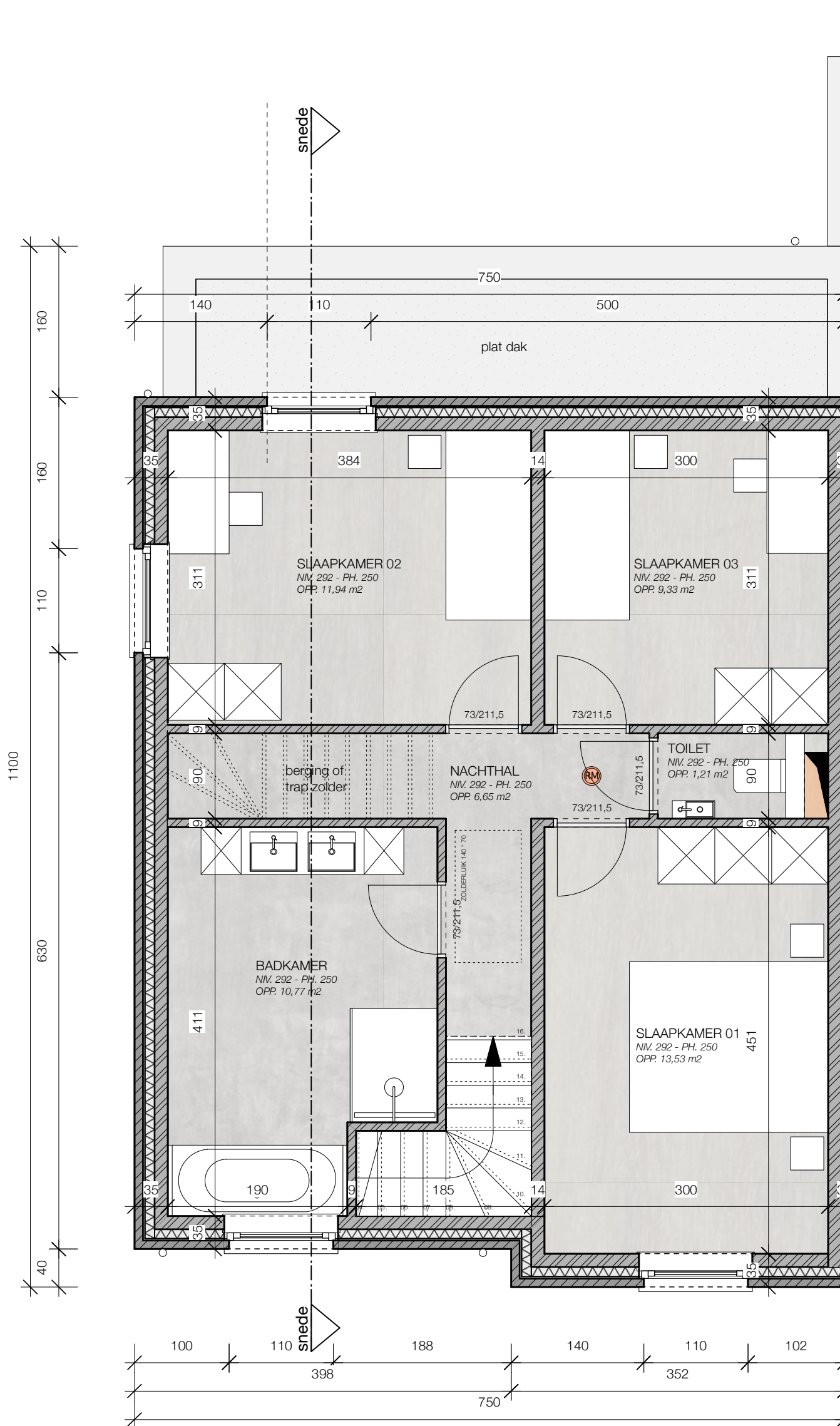

WONING LOT 1

OPP. 149 m²

(80 + 69) (EXCL. ZOLDER)

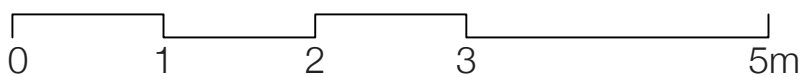
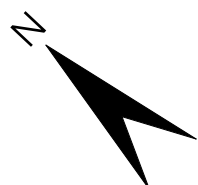

LAURIJSENS ARCHITECTS

lot 1 VERDIEPING
SCHAAL 1/50

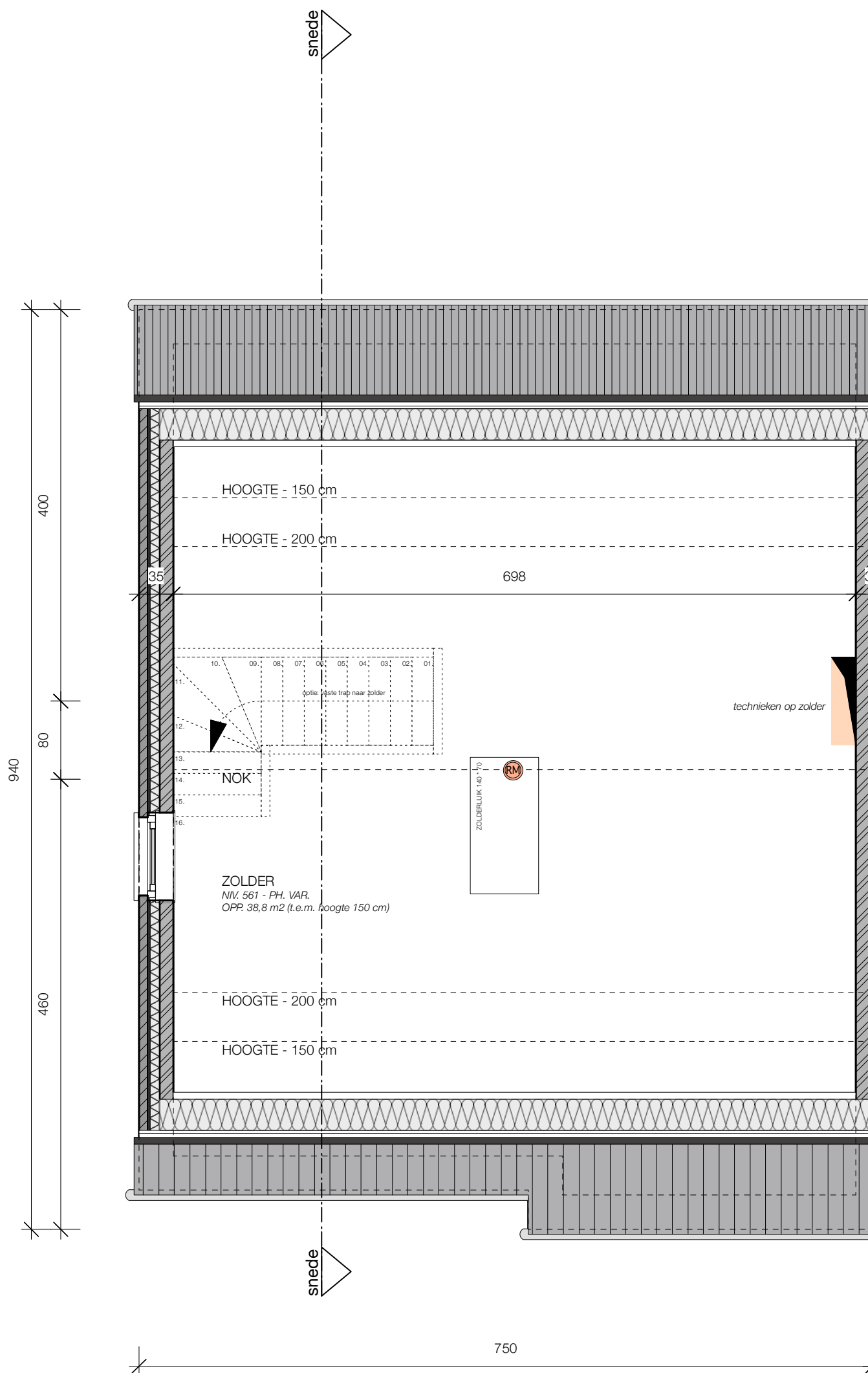

WONING LOT 1

OPP. 149 m²

(80 + 69) (EXCL. ZOLDER)

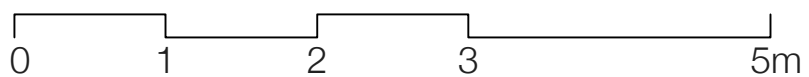
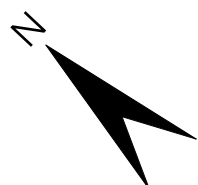

LAURIJSENS ARCHITECTS

lot 1 ZOLDER
SCHAAL 1/50

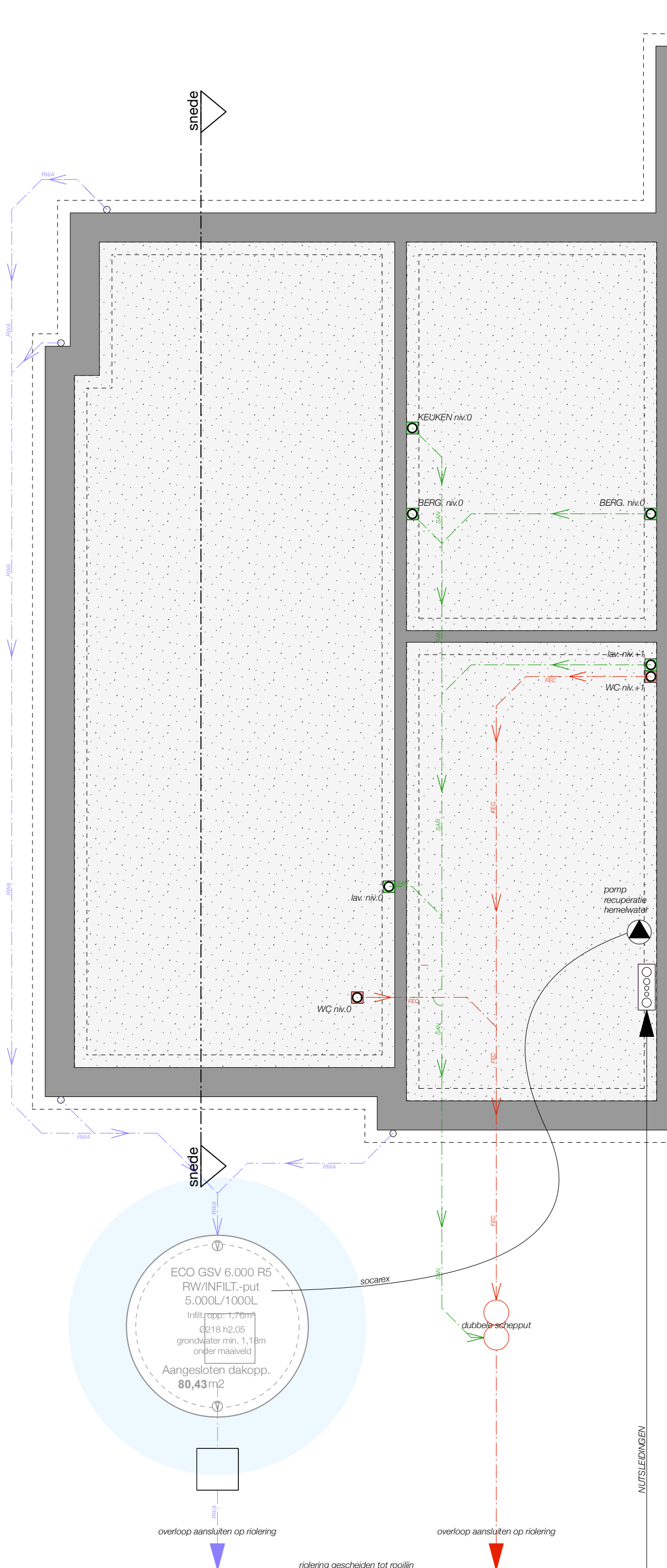

WONING LOT 1

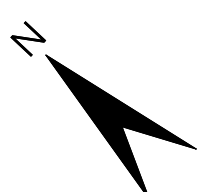

LAURIJSENS ARCHITECTS

lot 1 FUNDERING
SCHAAL 1/50

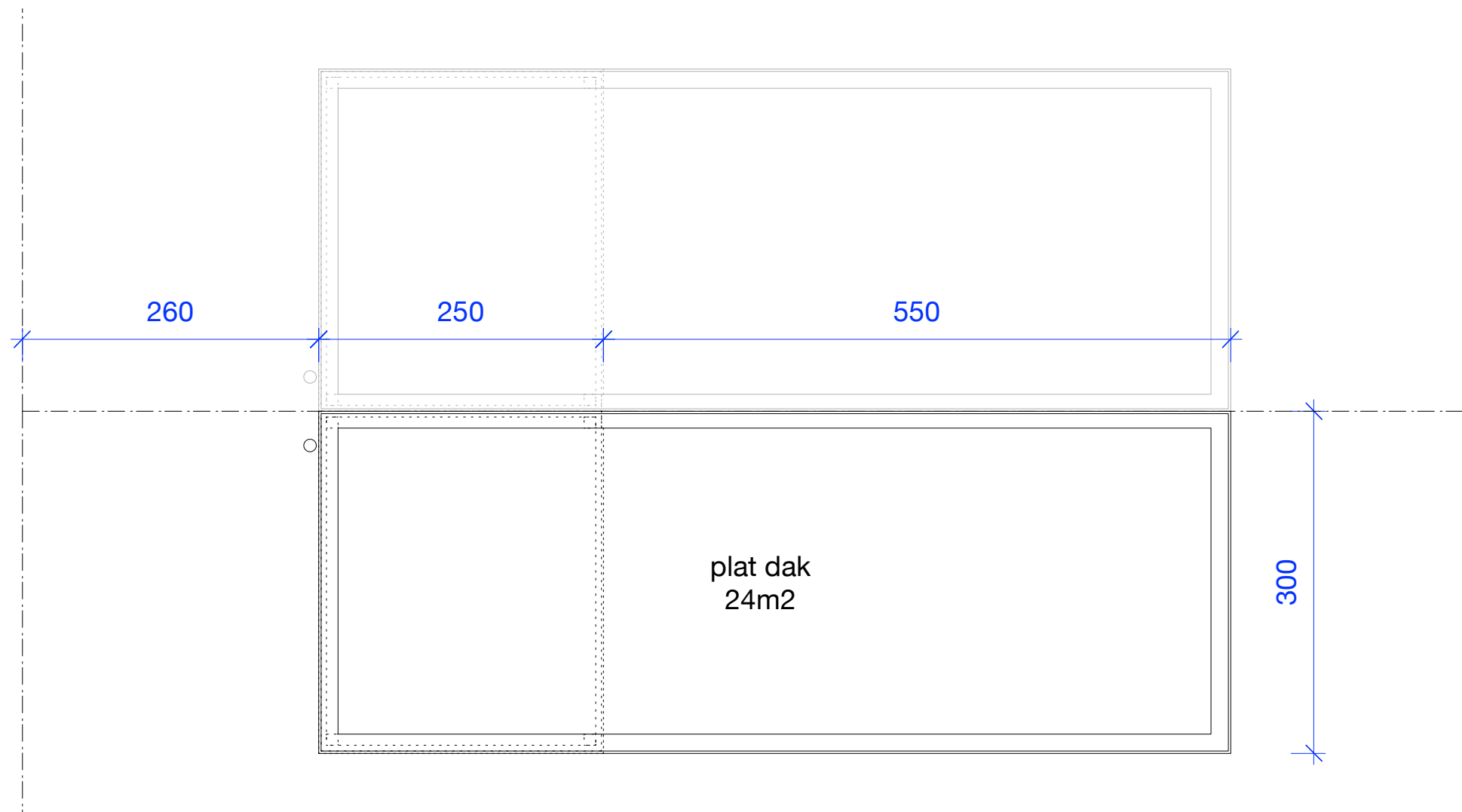

DAKENPLAN

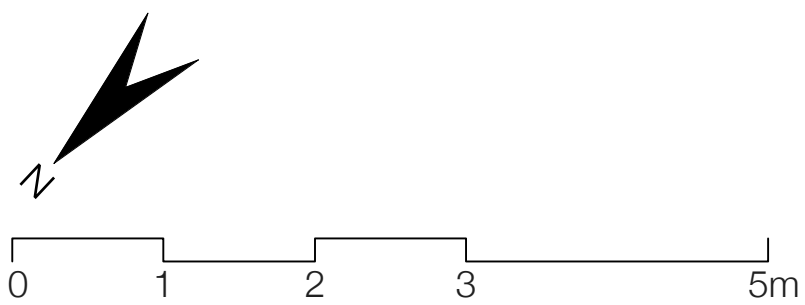

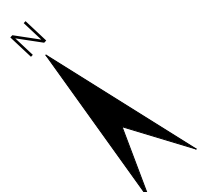
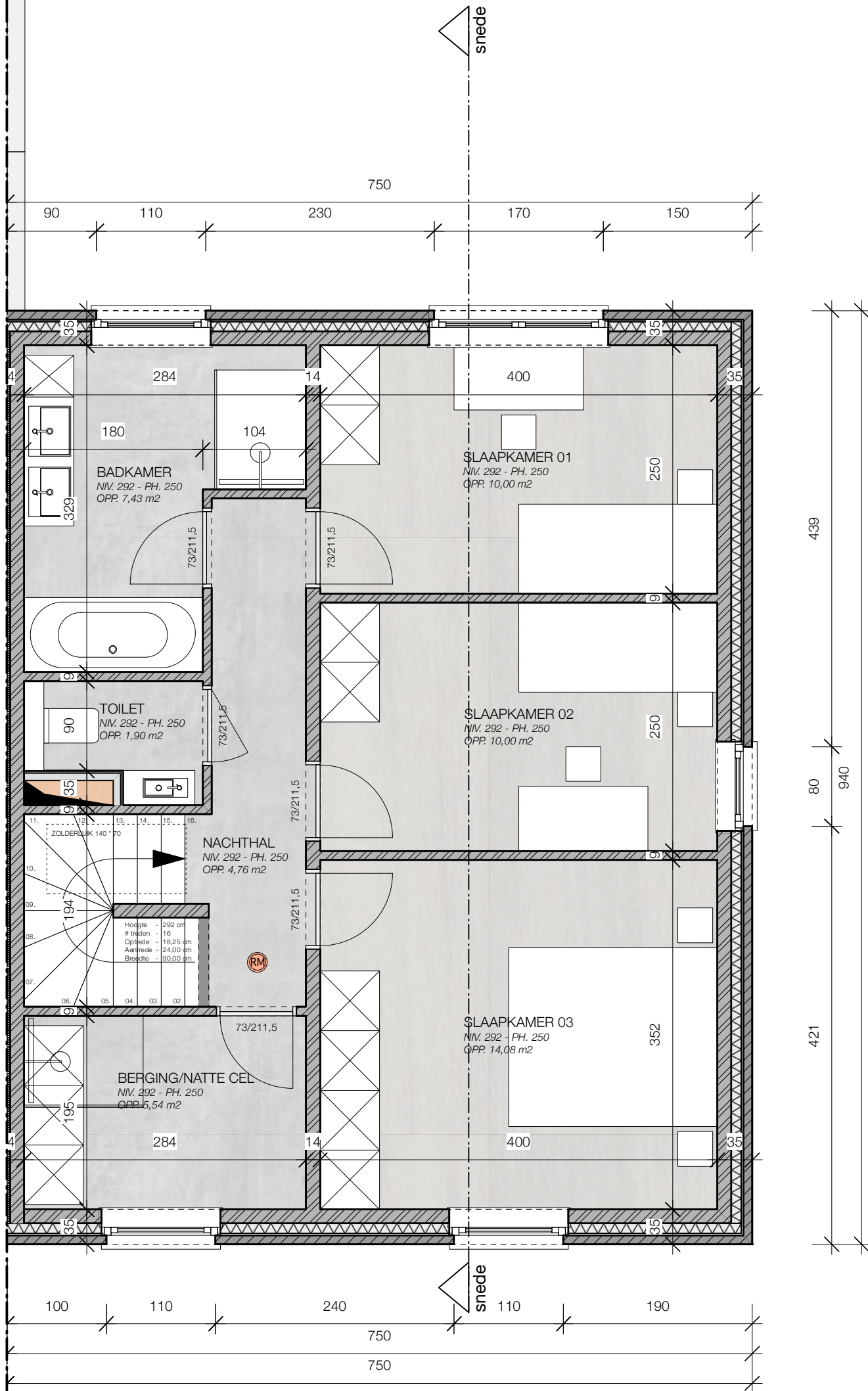

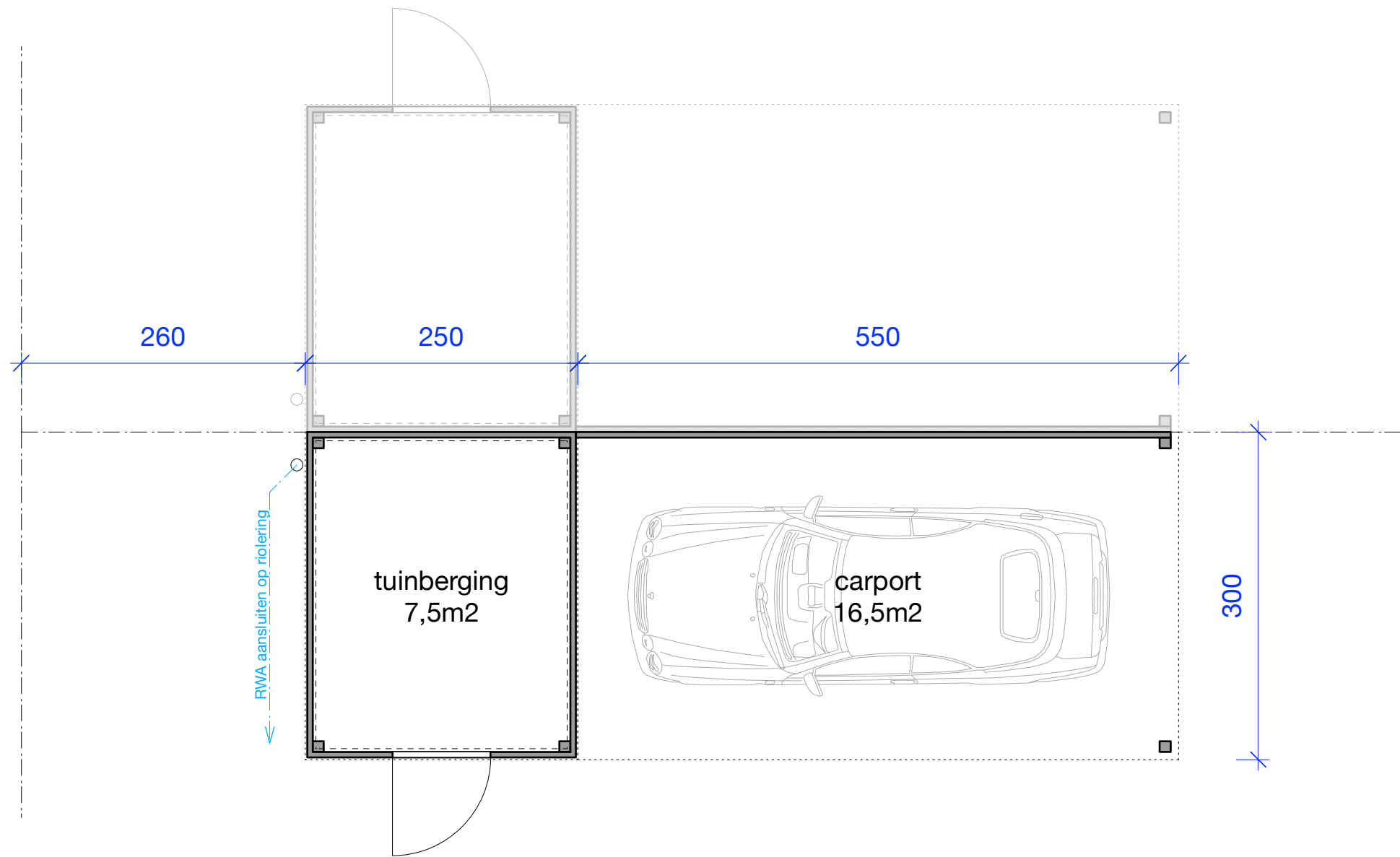

GRONDPLAN

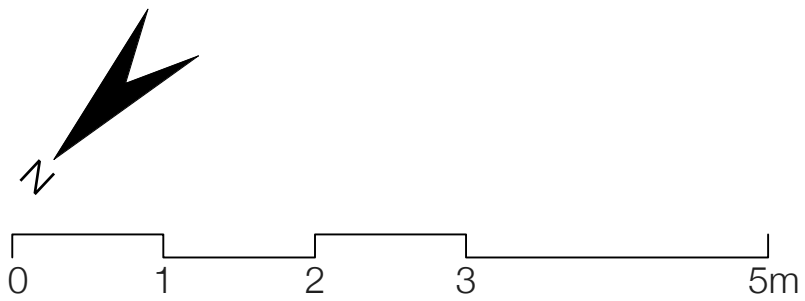

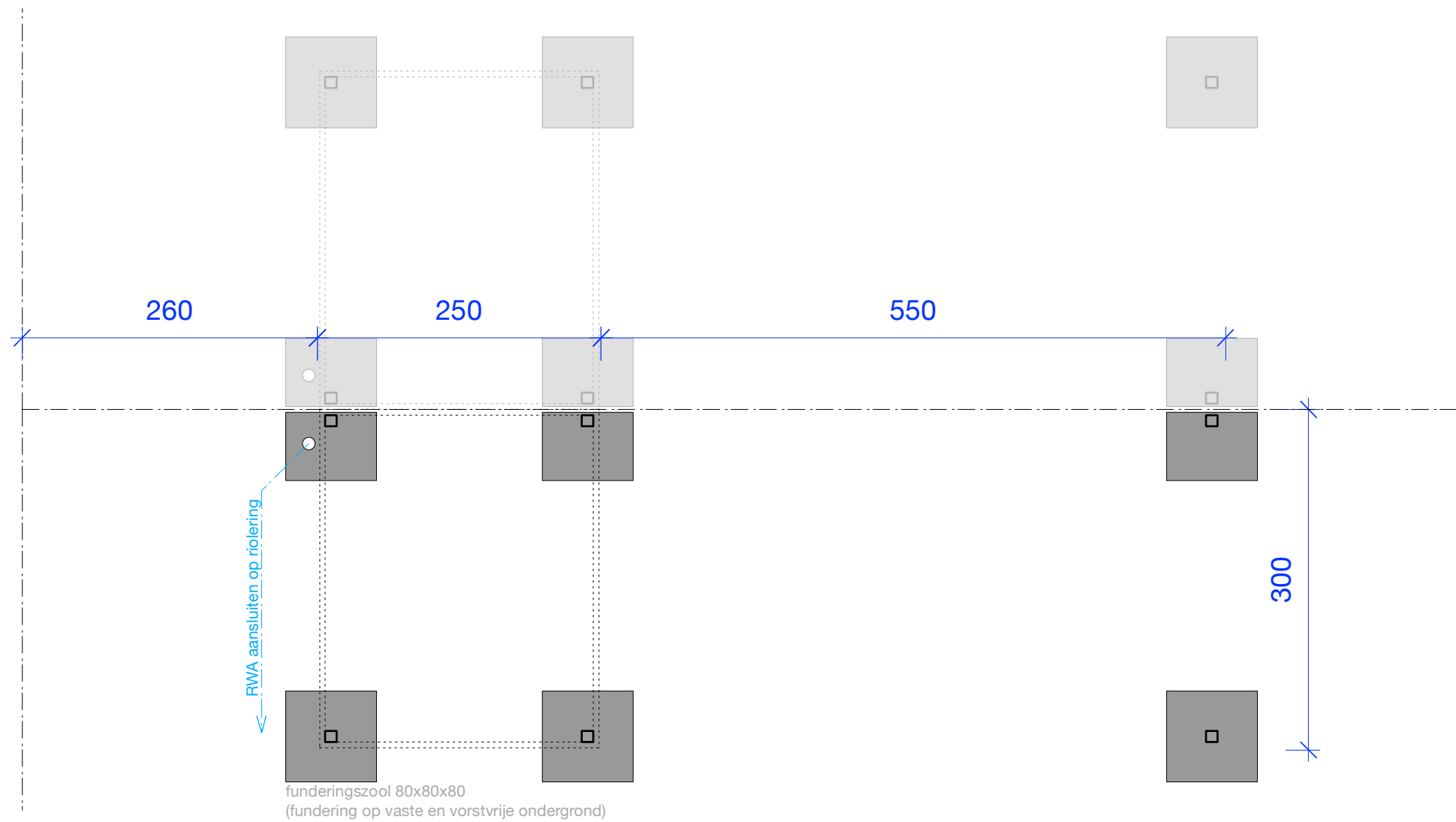

FUNDERINGSPLAN

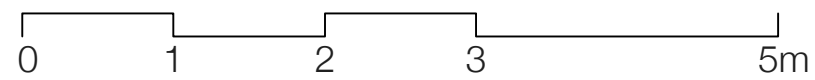

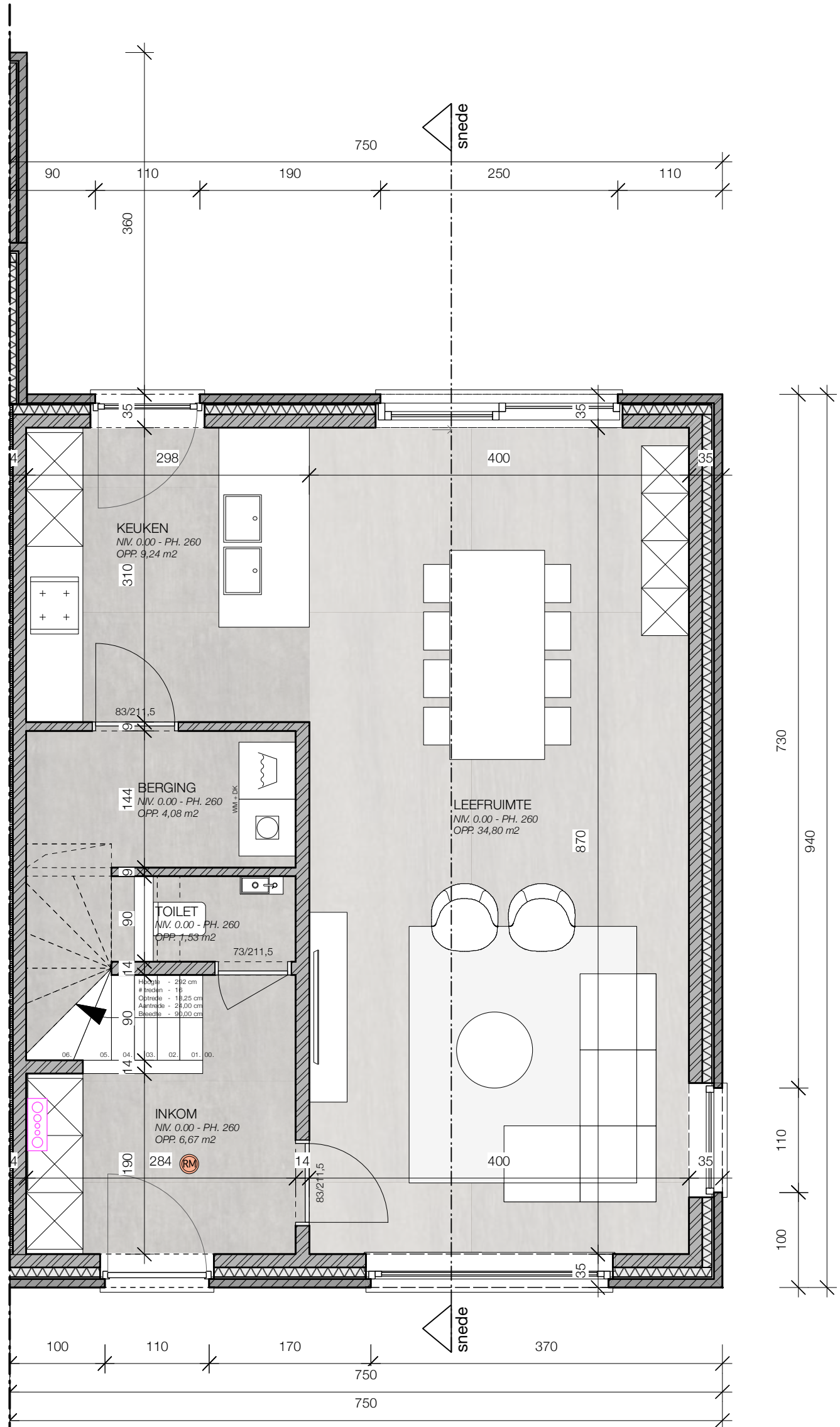

WONING LOT 2

OPP. 141 m²
(70,5 + 70,5) (EXCL. ZOLDER)

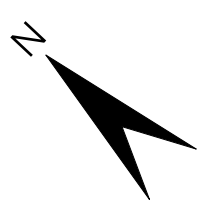

LAURIJSENS ARCHITECTS

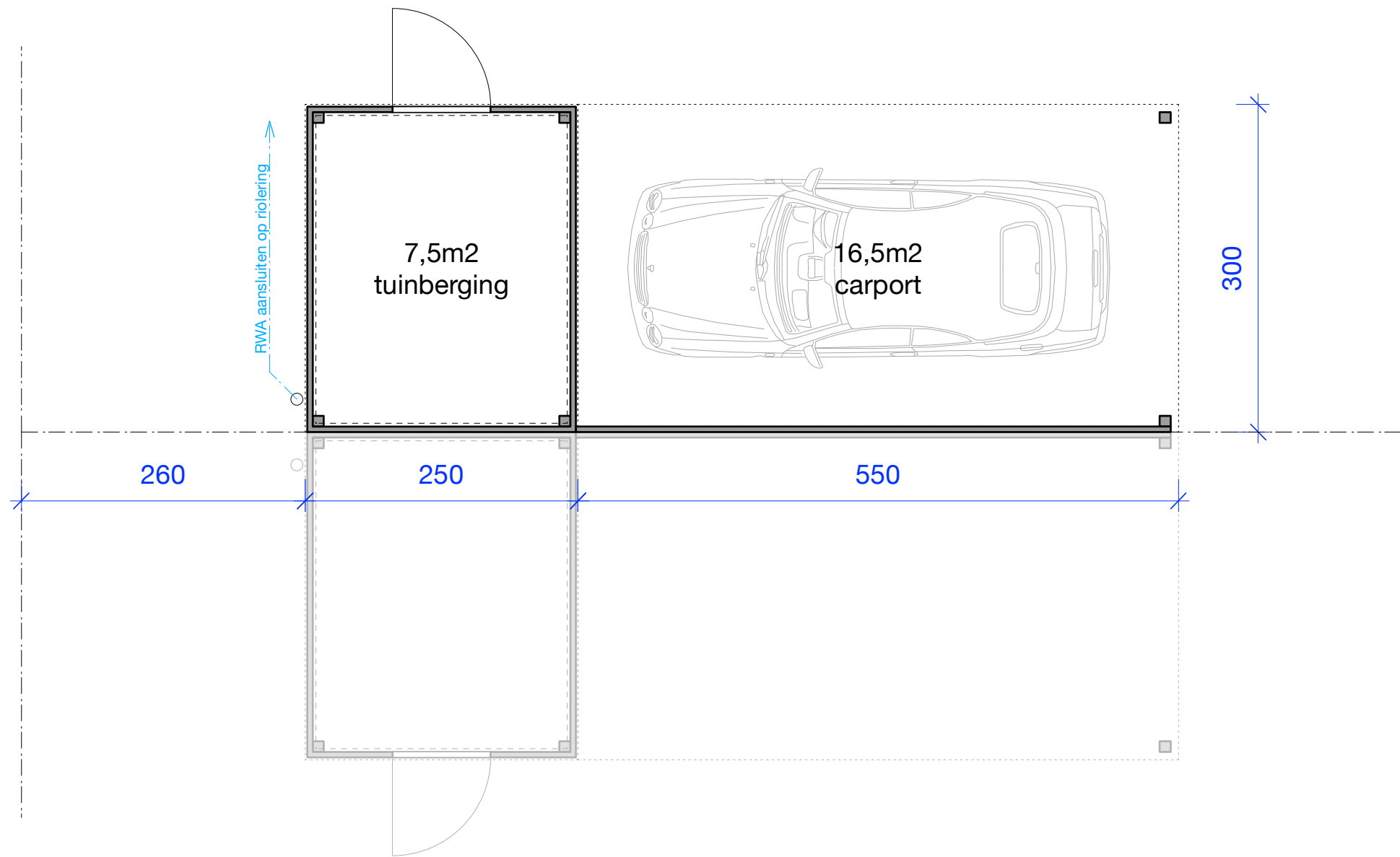

GRONDPLAN

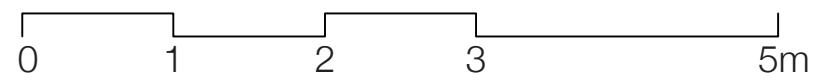
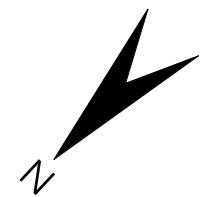

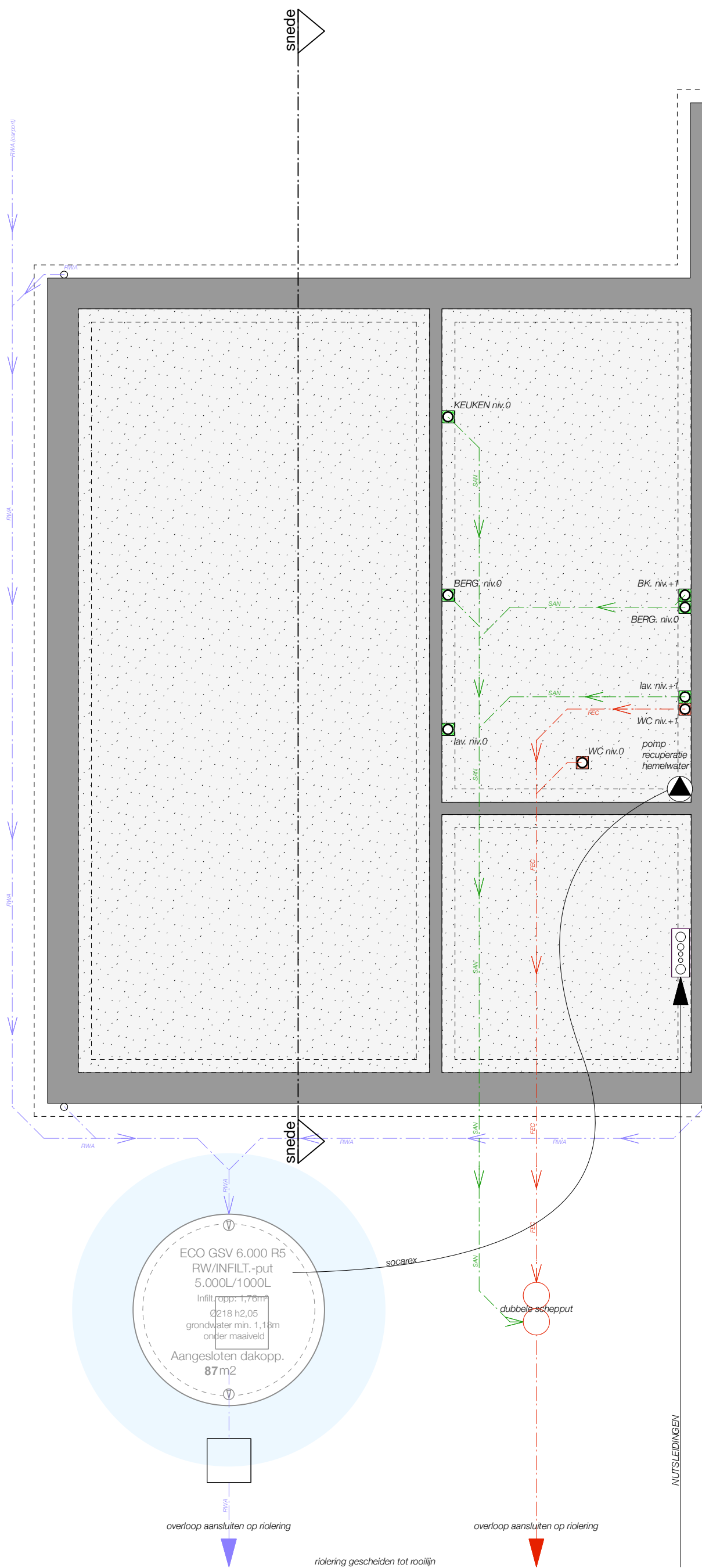

WONING LOT 3

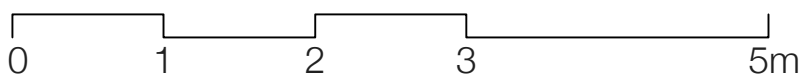

LAURIJSENS ARCHITECTS

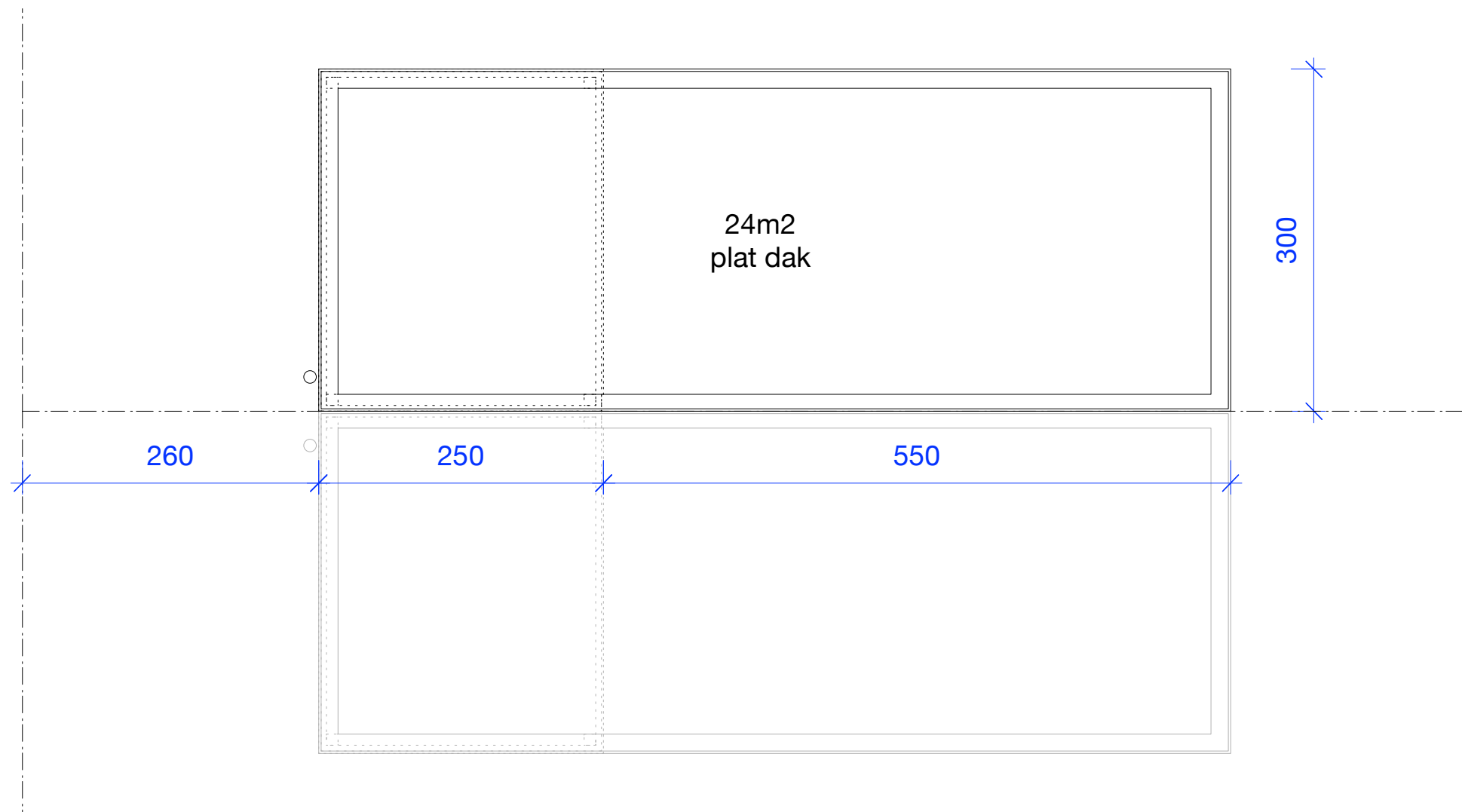

DAKENPLAN

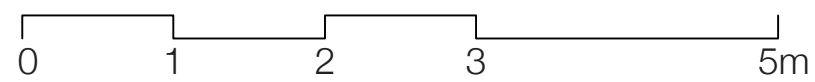

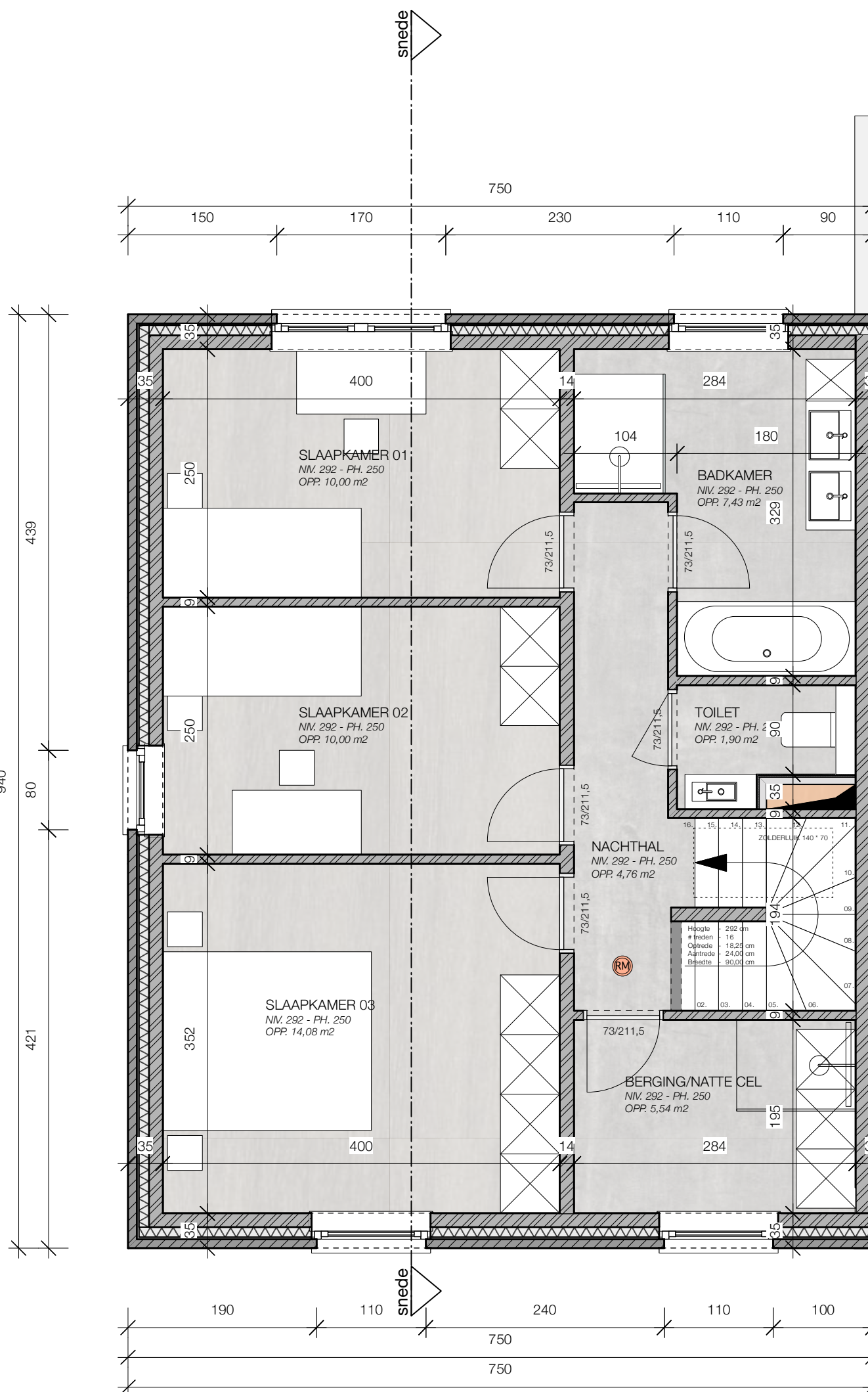

WONING LOT 3

OPP. 141 m²
(70,5 + 70,5) (EXCL. ZOLDER)

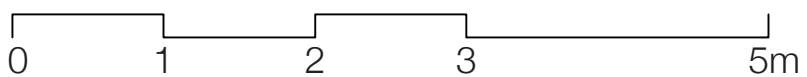
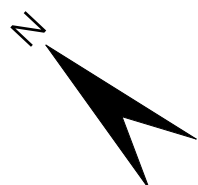

LAURIJSENS ARCHITECTS

lot 3 VERDIEPING
SCHAAL 1/50

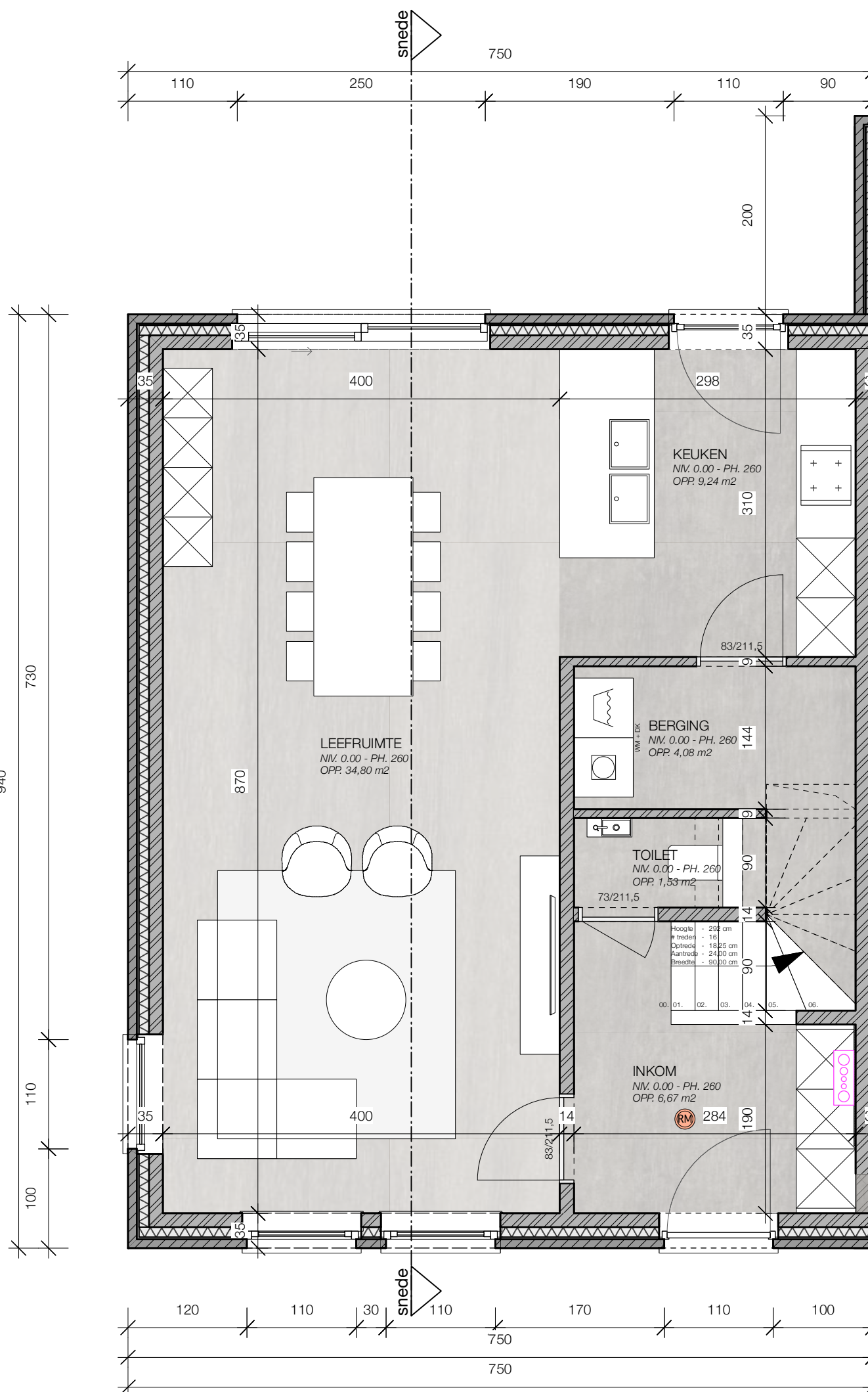

WONING LOT 3

OPP. 141 m²
(70,5 + 70,5) (EXCL. ZOLDER)

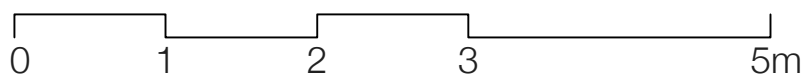
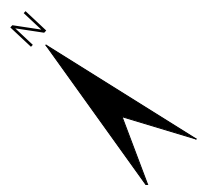

LAURIJSENS ARCHITECTS

lot 3 GELIJKVLOERS
 SCHAAL 1/50

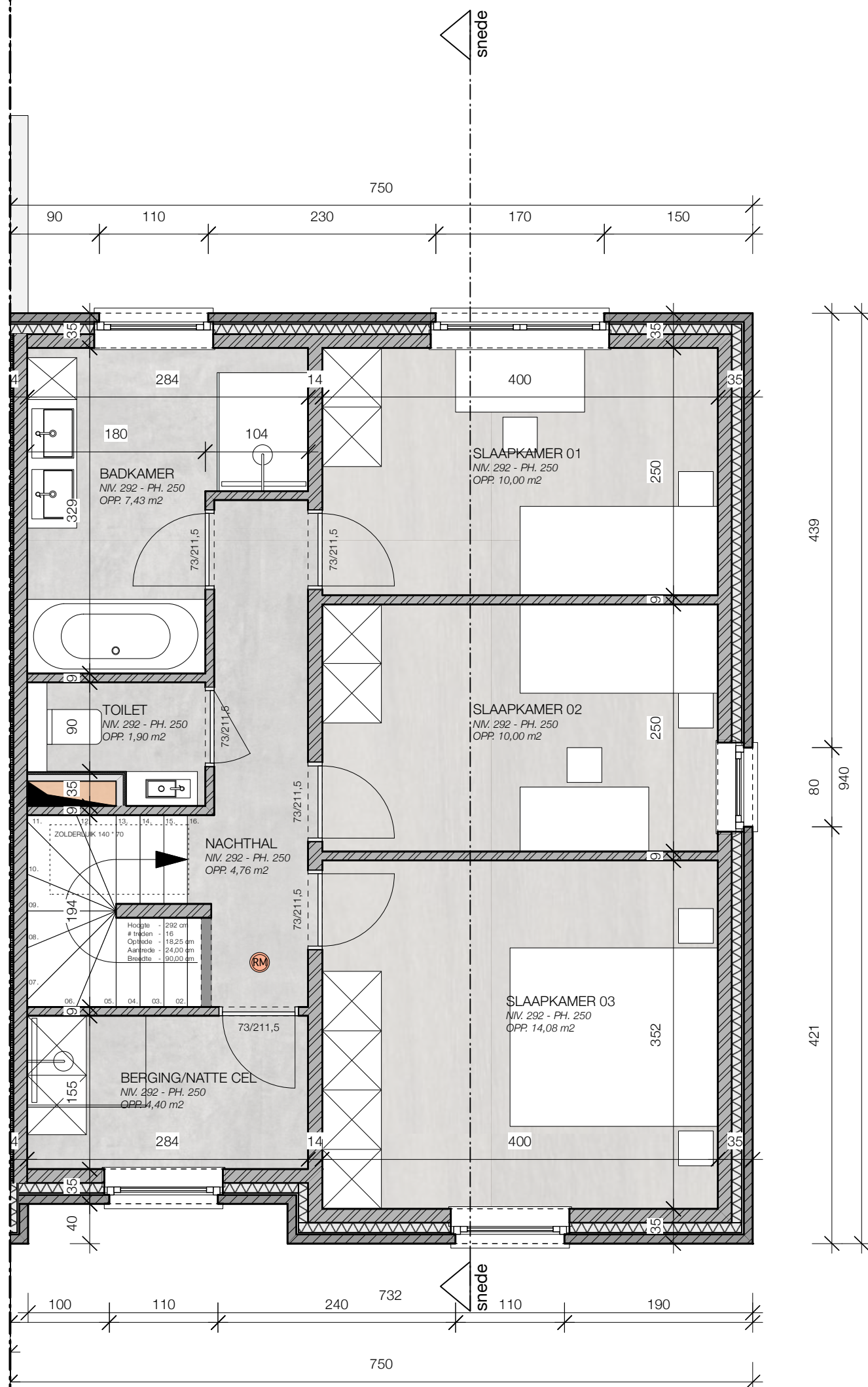

WONING LOT 4

OPP. 139 m²
(69,5 + 69,5) (EXCL. ZOLDER)

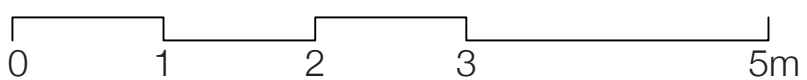
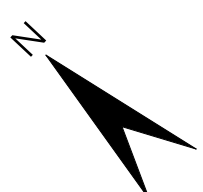

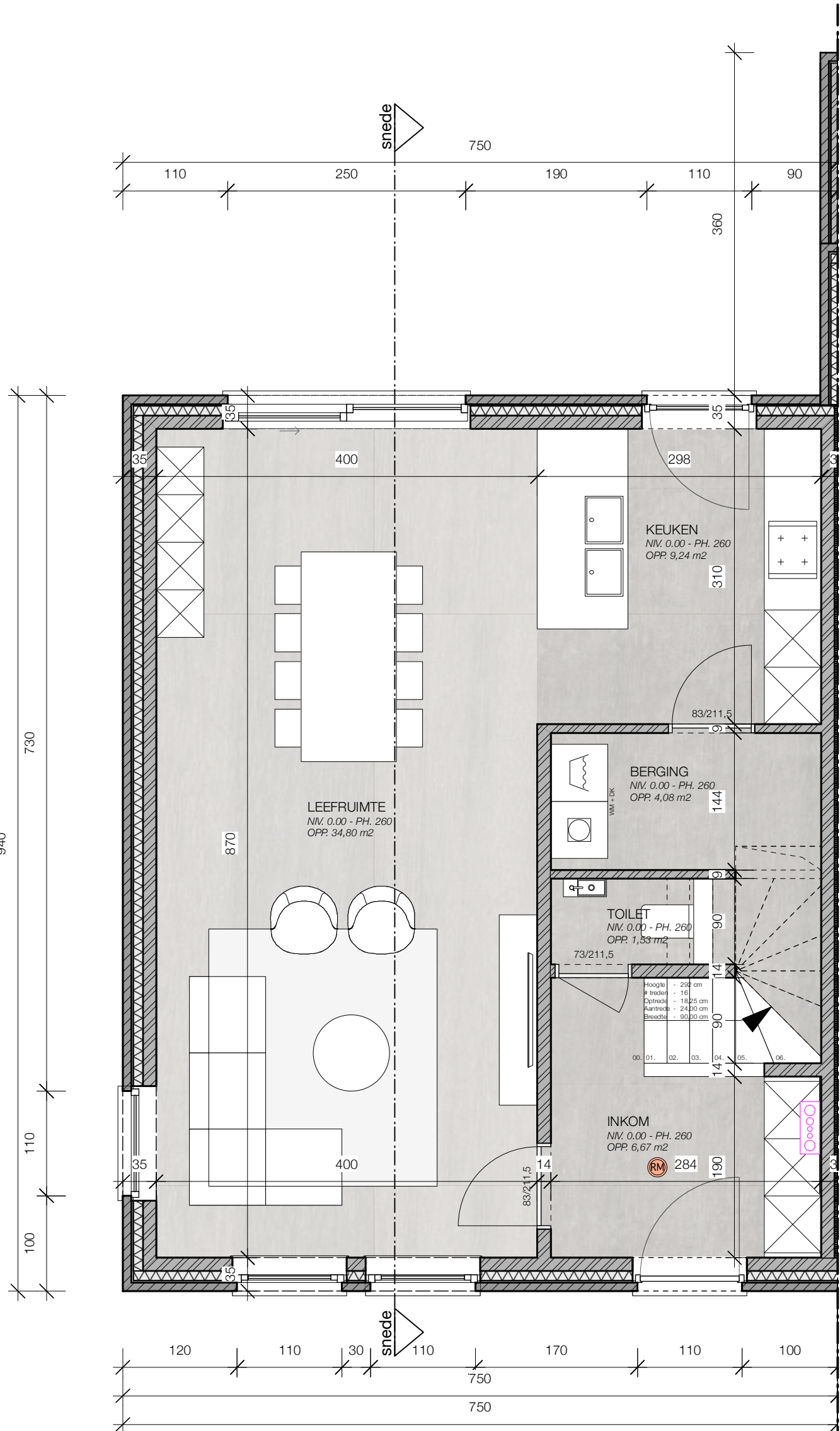

WONING LOT 5

OPP. 141 m²
(70,5 + 70,5) (EXCL. ZOLDER)

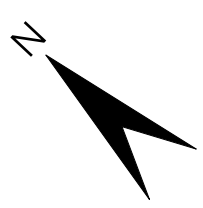

LAURIJSENS ARCHITECTS

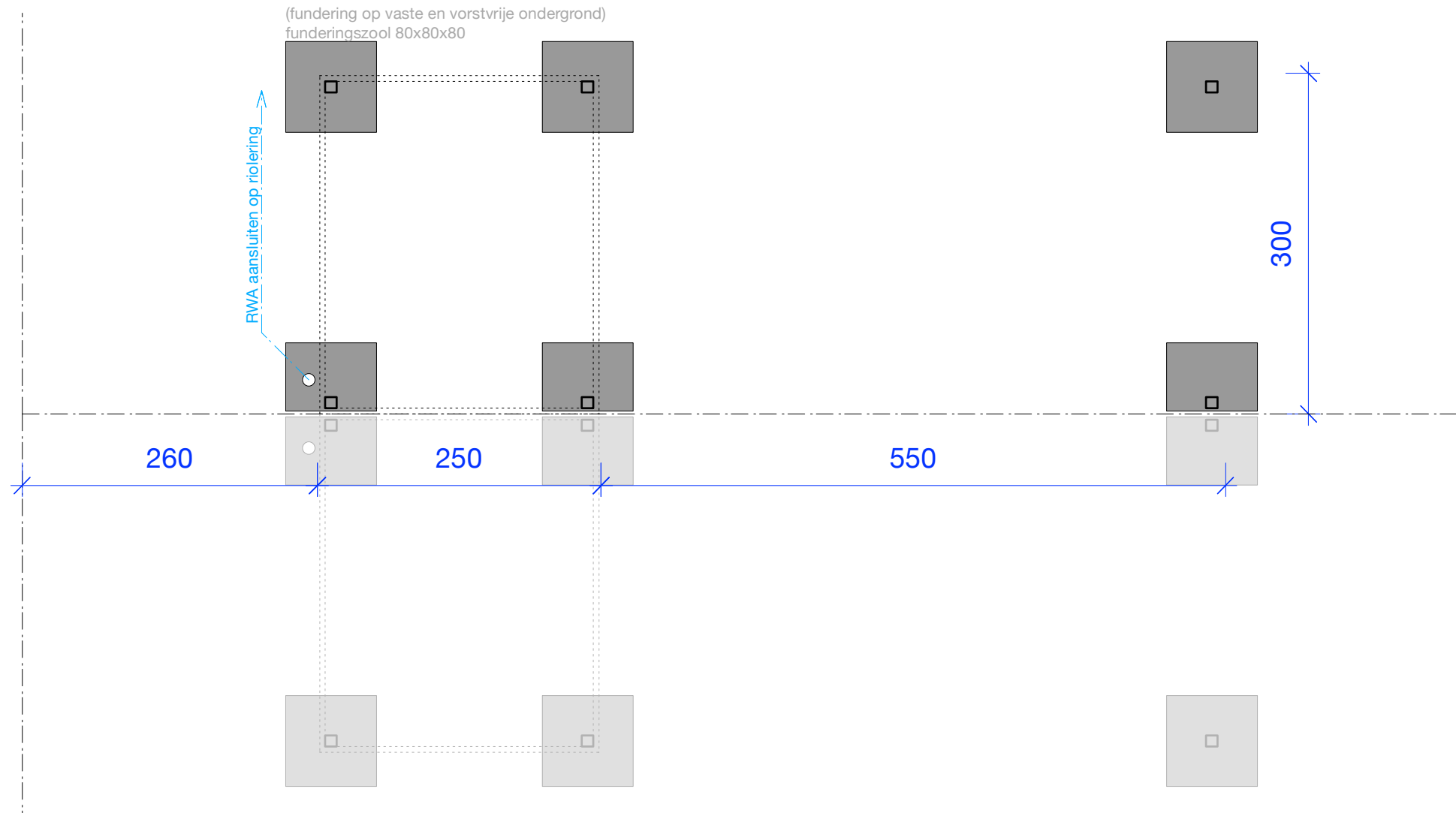

FUNDERINGSPLAN

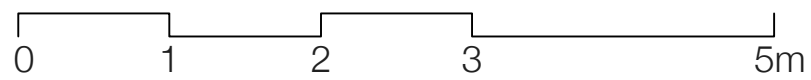
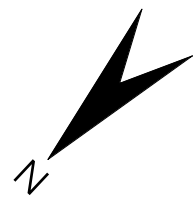

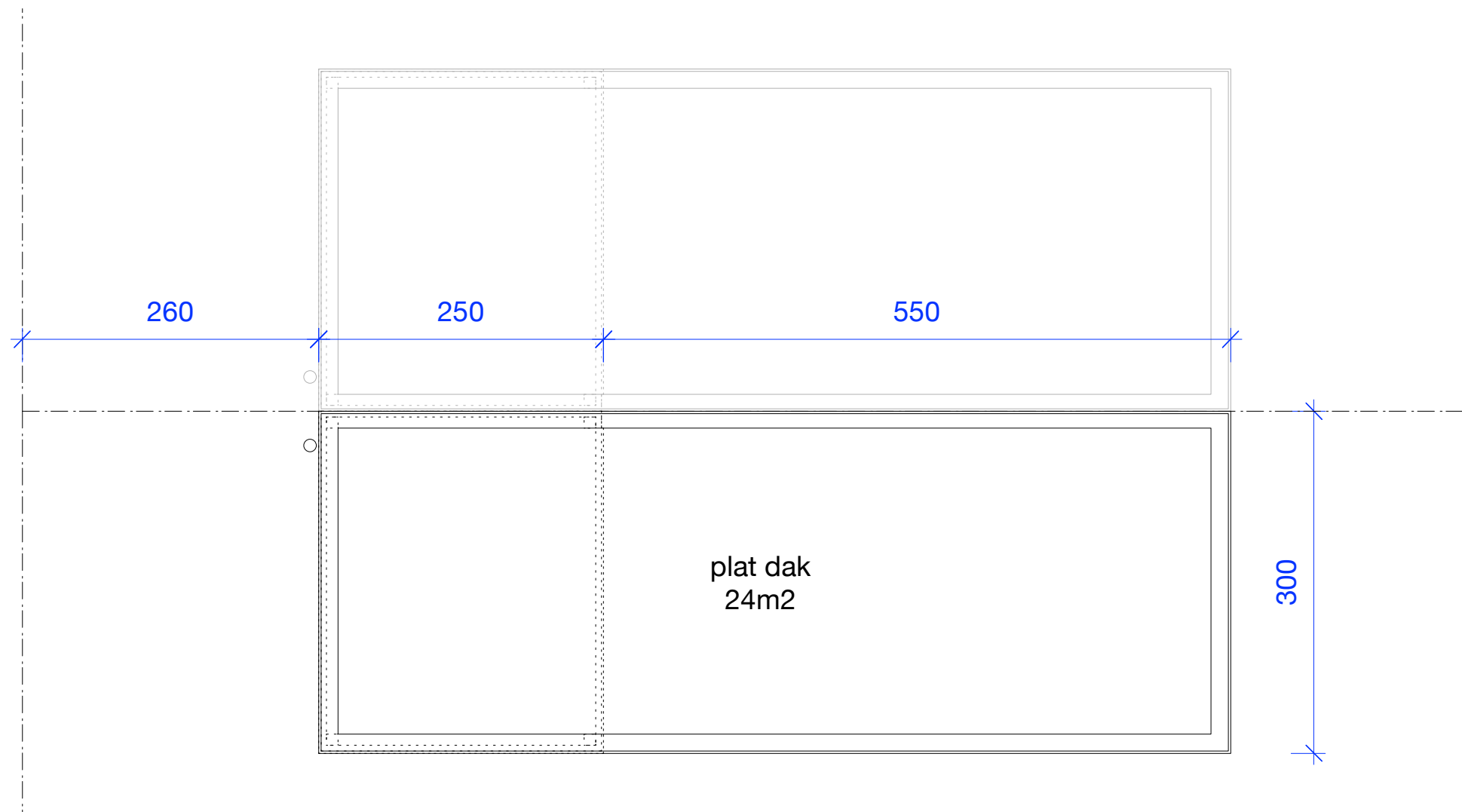

DAKENPLAN

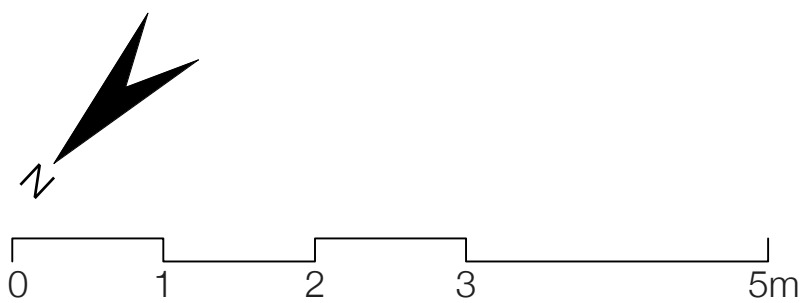

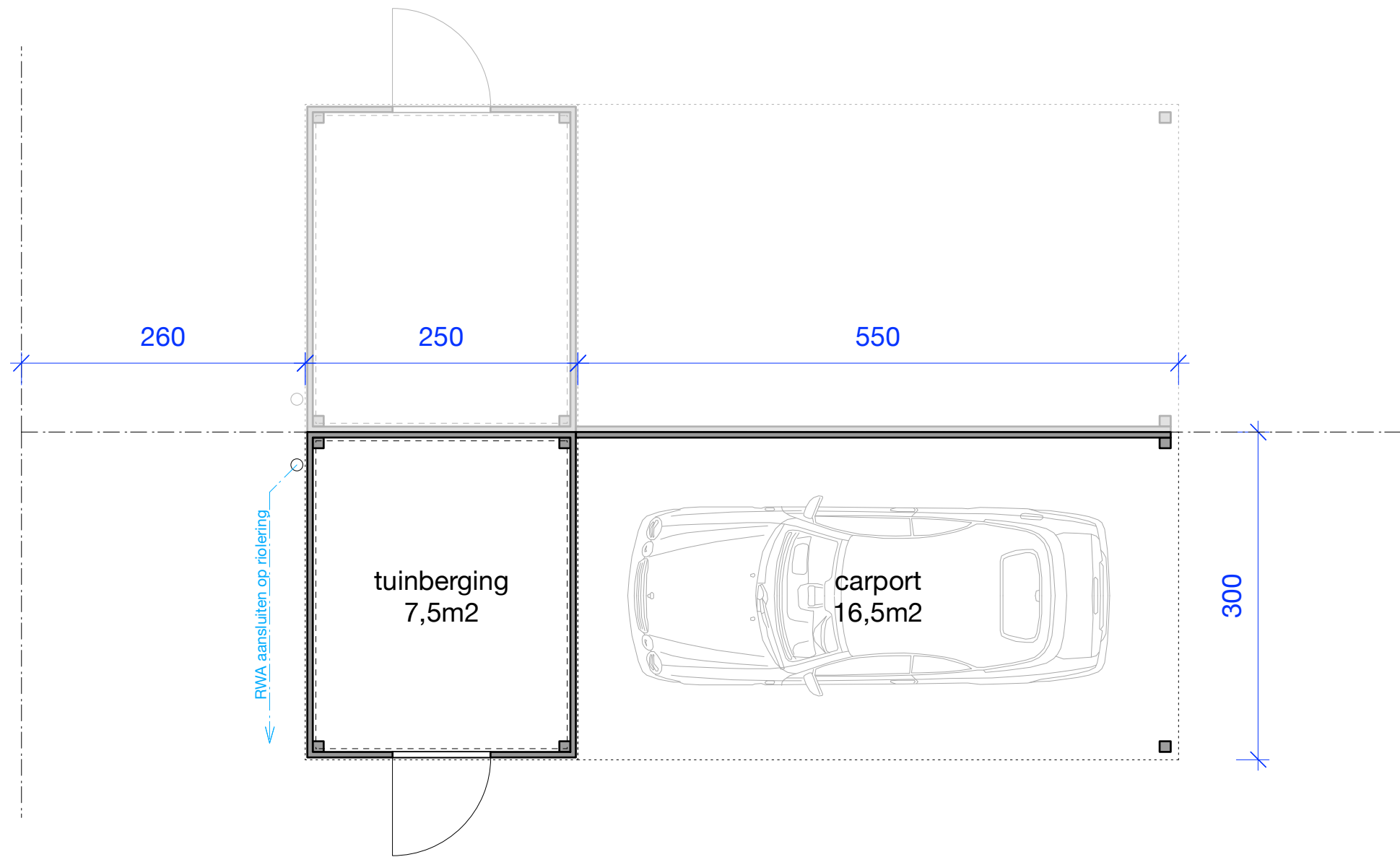

GRONDPLAN

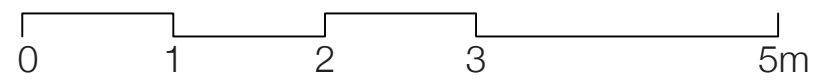
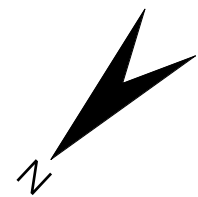

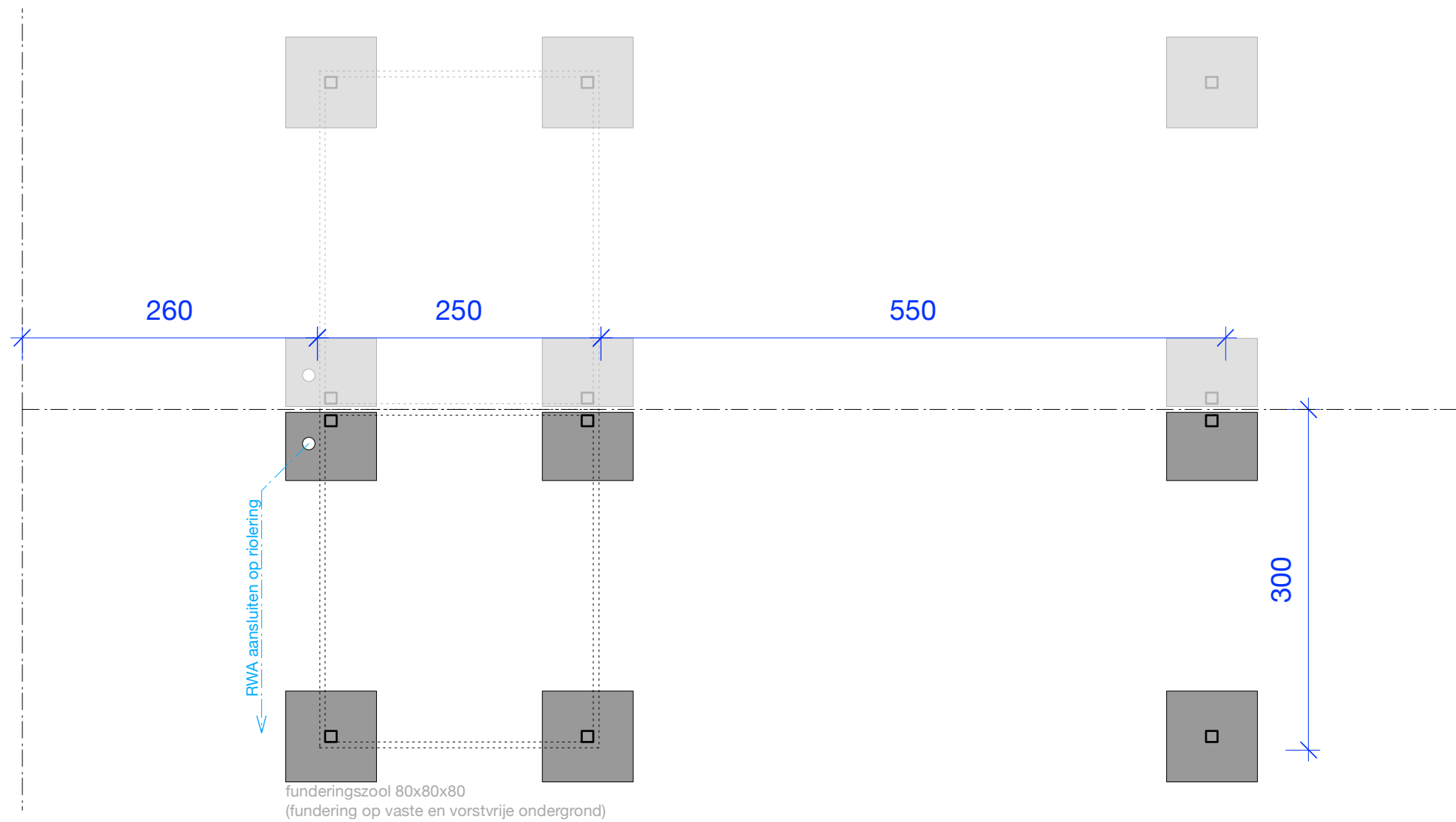

FUNDERINGSPLAN

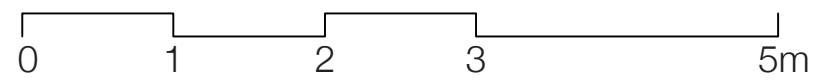
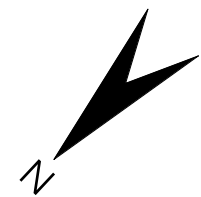

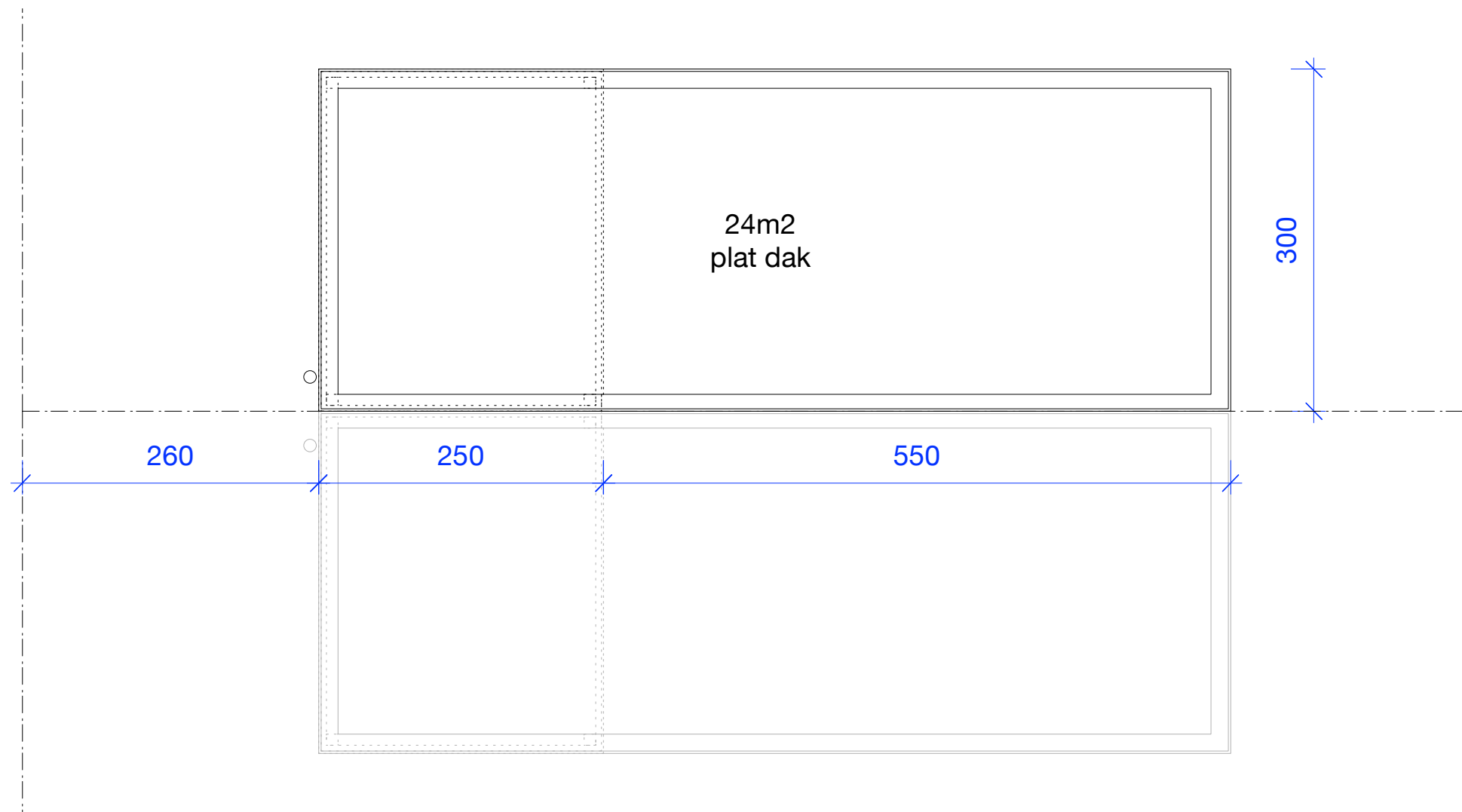

DAKENPLAN

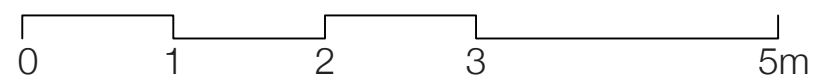
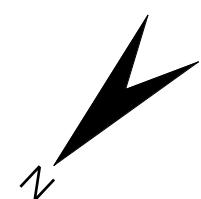

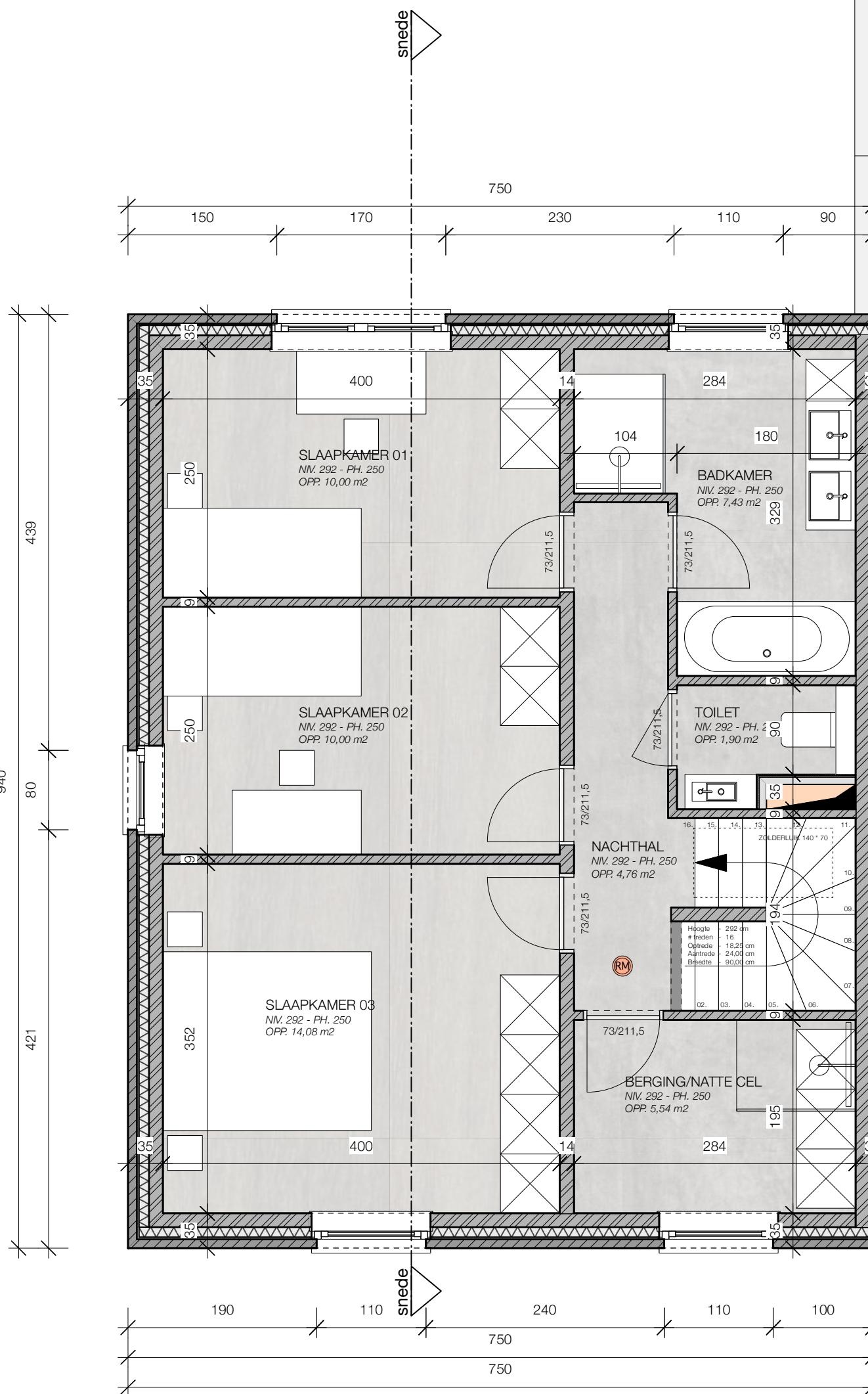

WONING LOT 5

OPP. 141 m²
(70,5 + 70,5) (EXCL. ZOLDER)



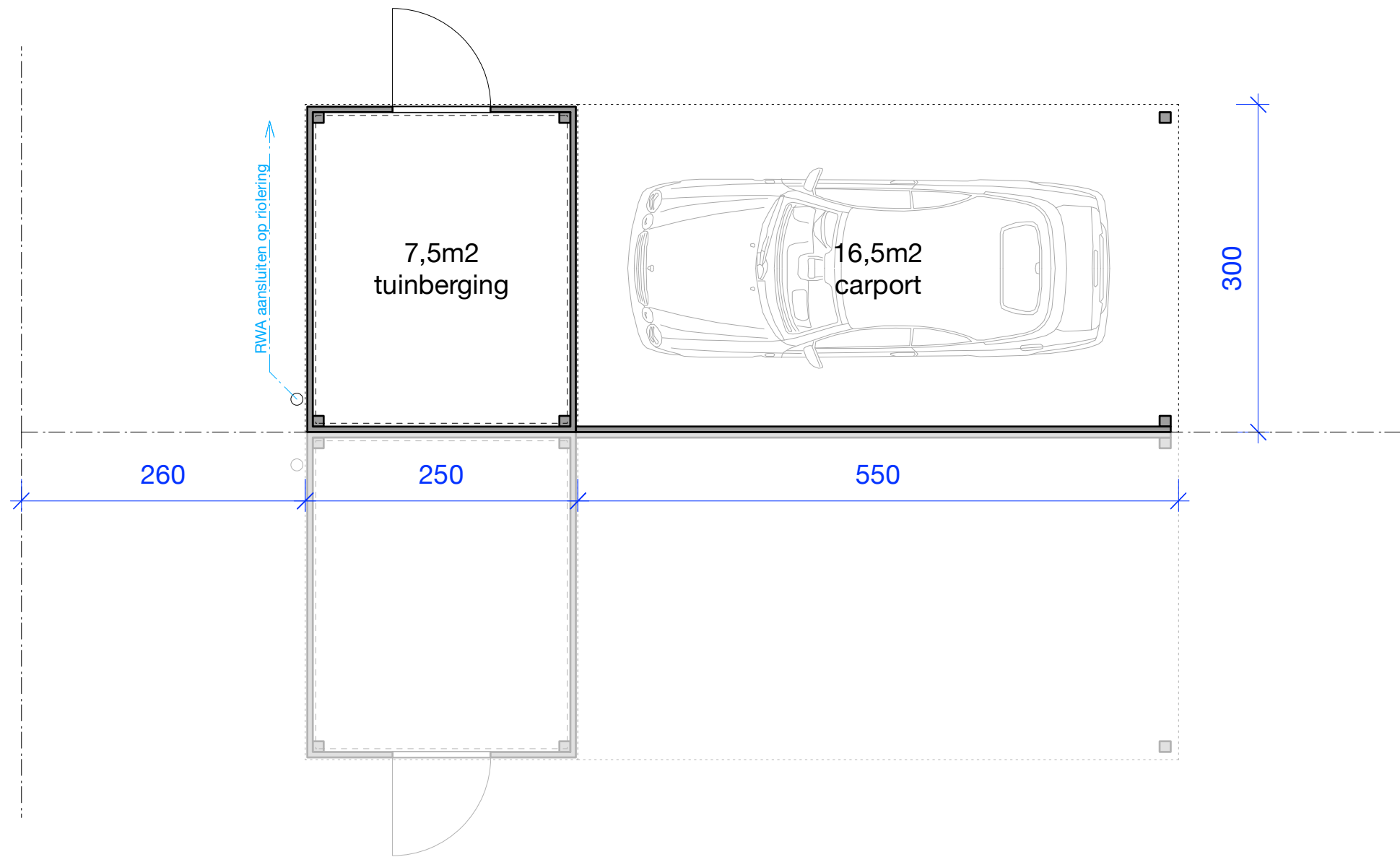

GRONDPLAN

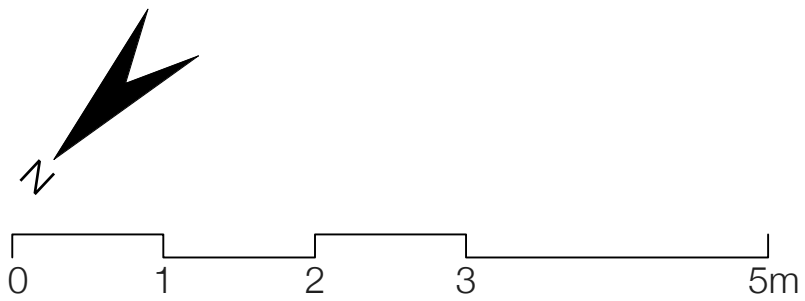

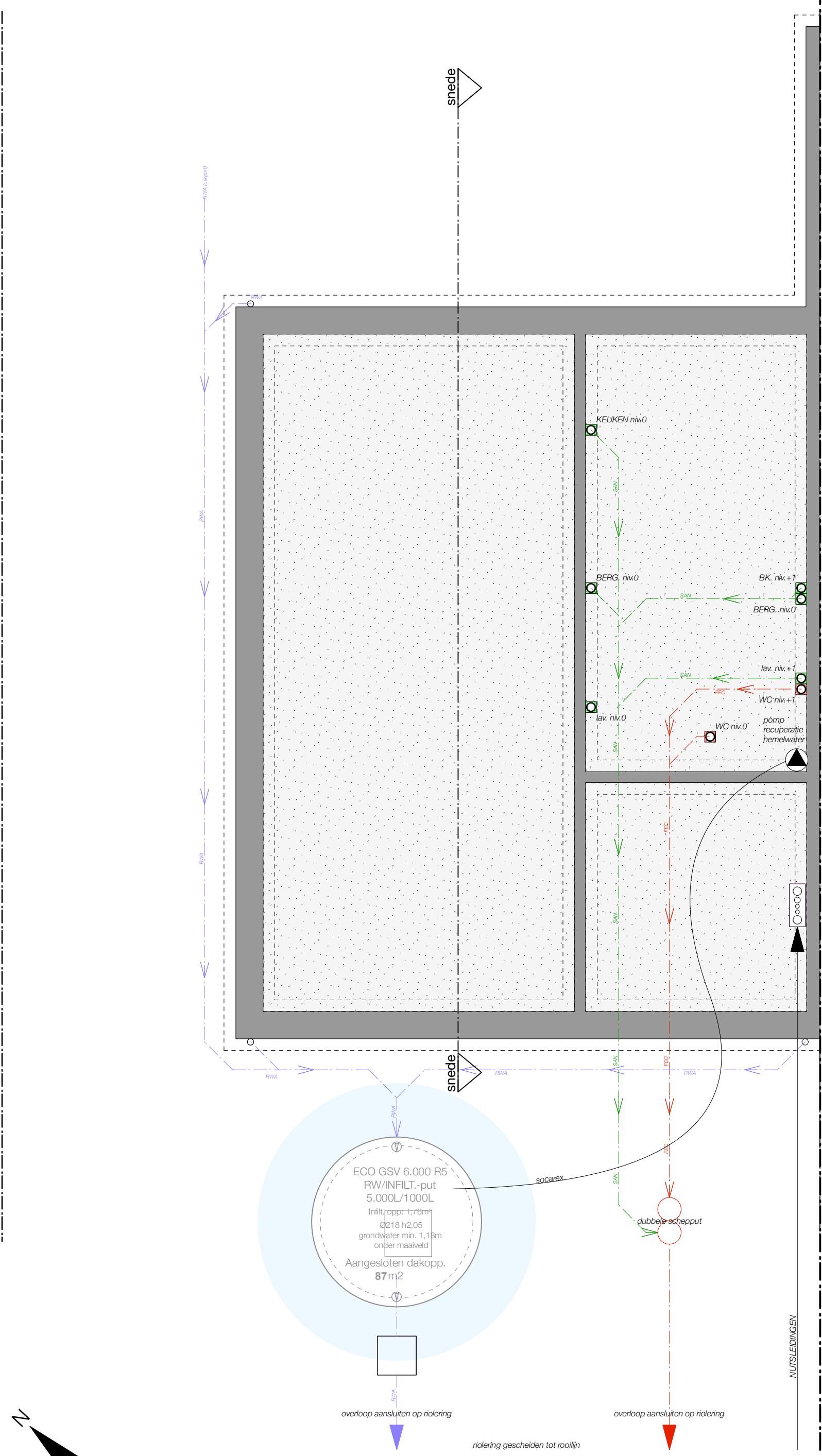

WONING LOT 5



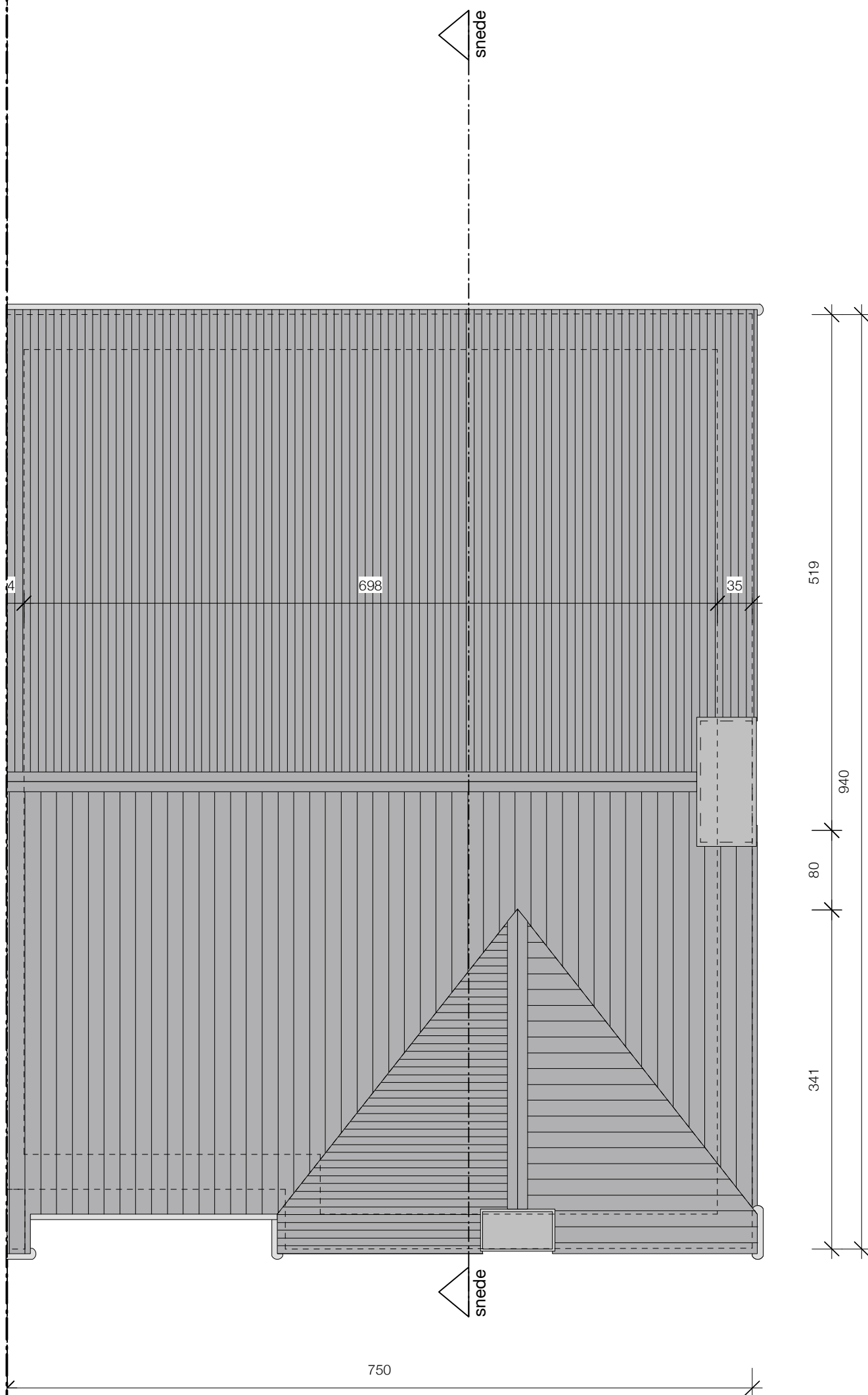

WONING LOT 4

OPP. 139 m²
 (69,5 + 69,5) (EXCL. ZOLDER)

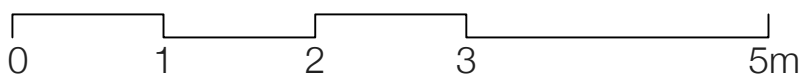
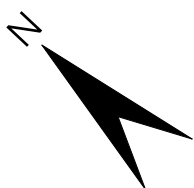

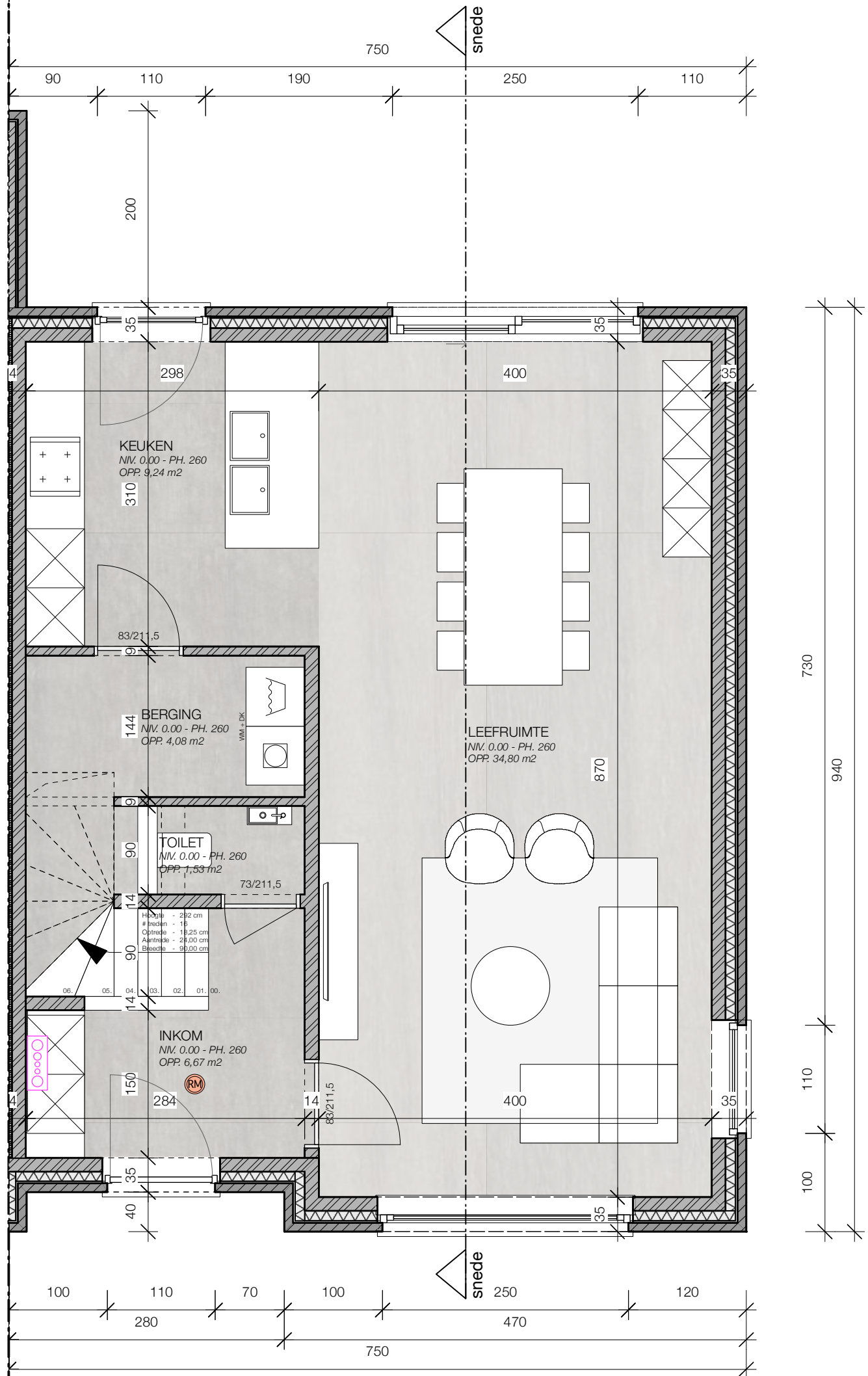

WONING LOT 4

OPP. 139 m²

(69,5 + 69,5) (EXCL. ZOLDER)

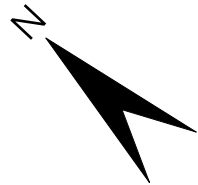

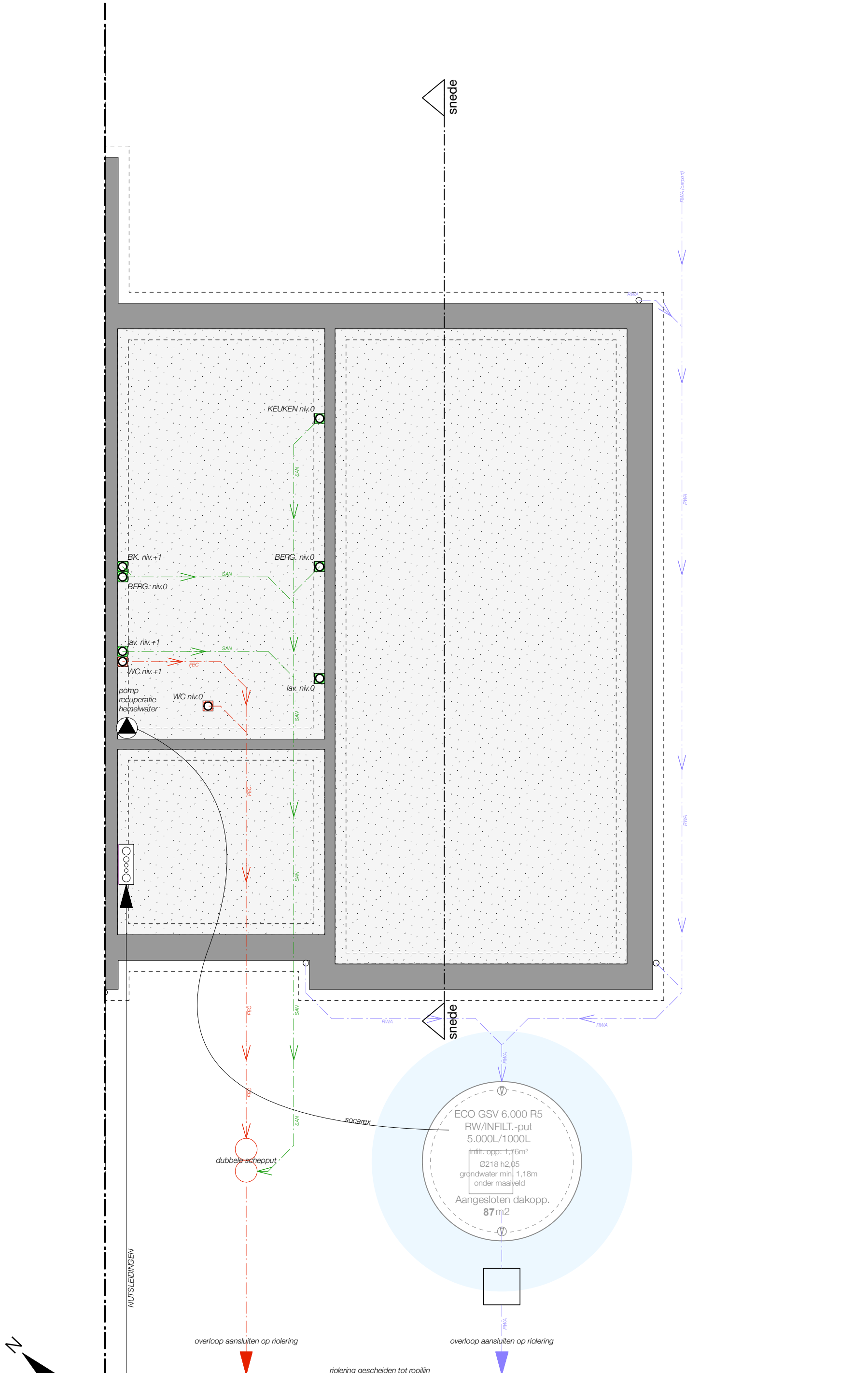

WONING LOT 4

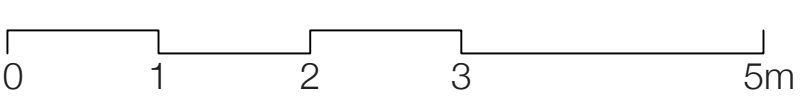

LAURIJSENS ARCHITECTS

lot 4 FUNDERING
SCHAAL 1/50

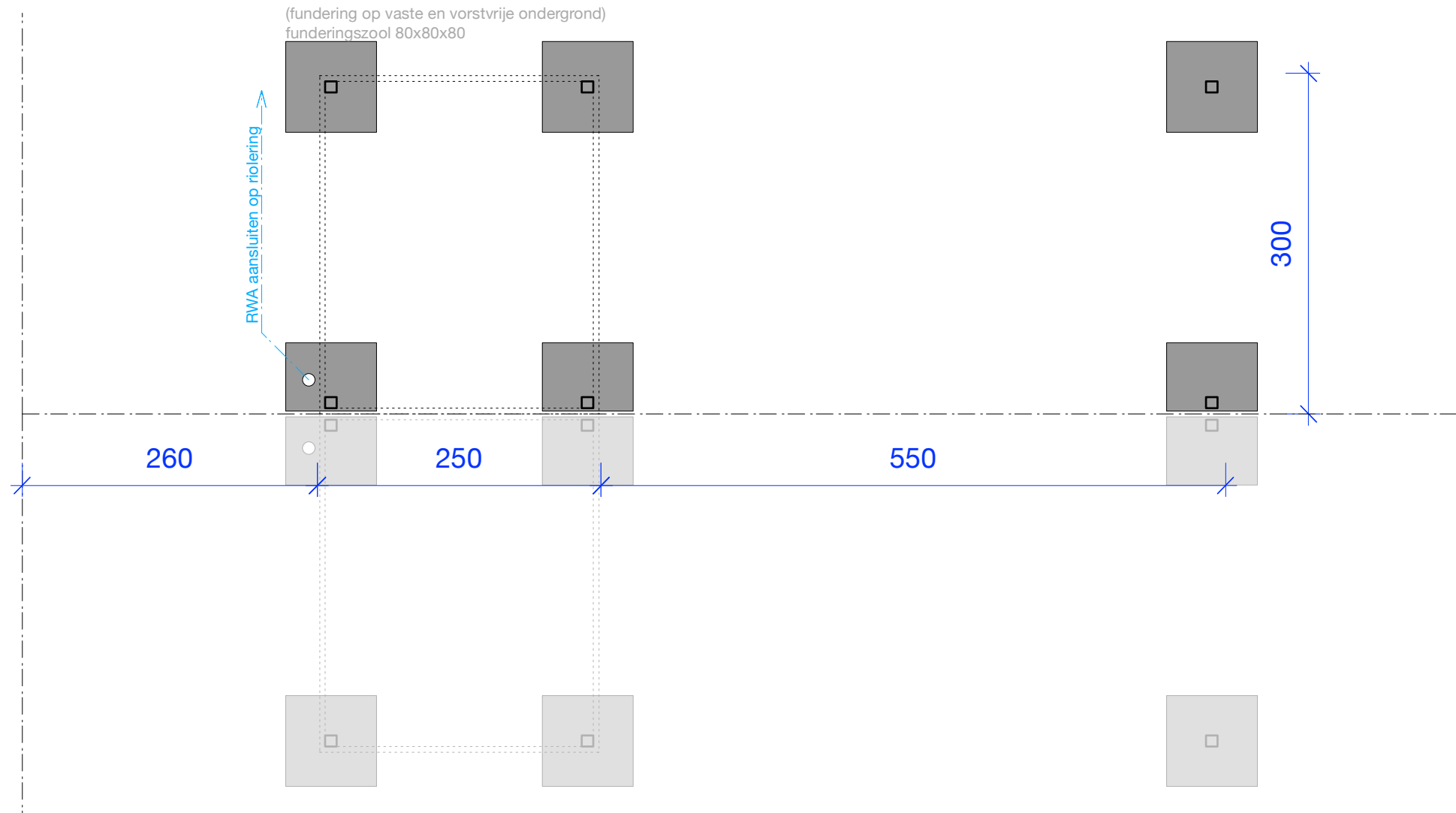

FUNDERINGSPLAN

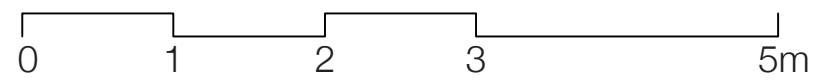
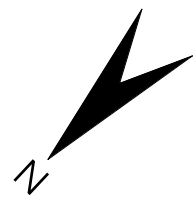

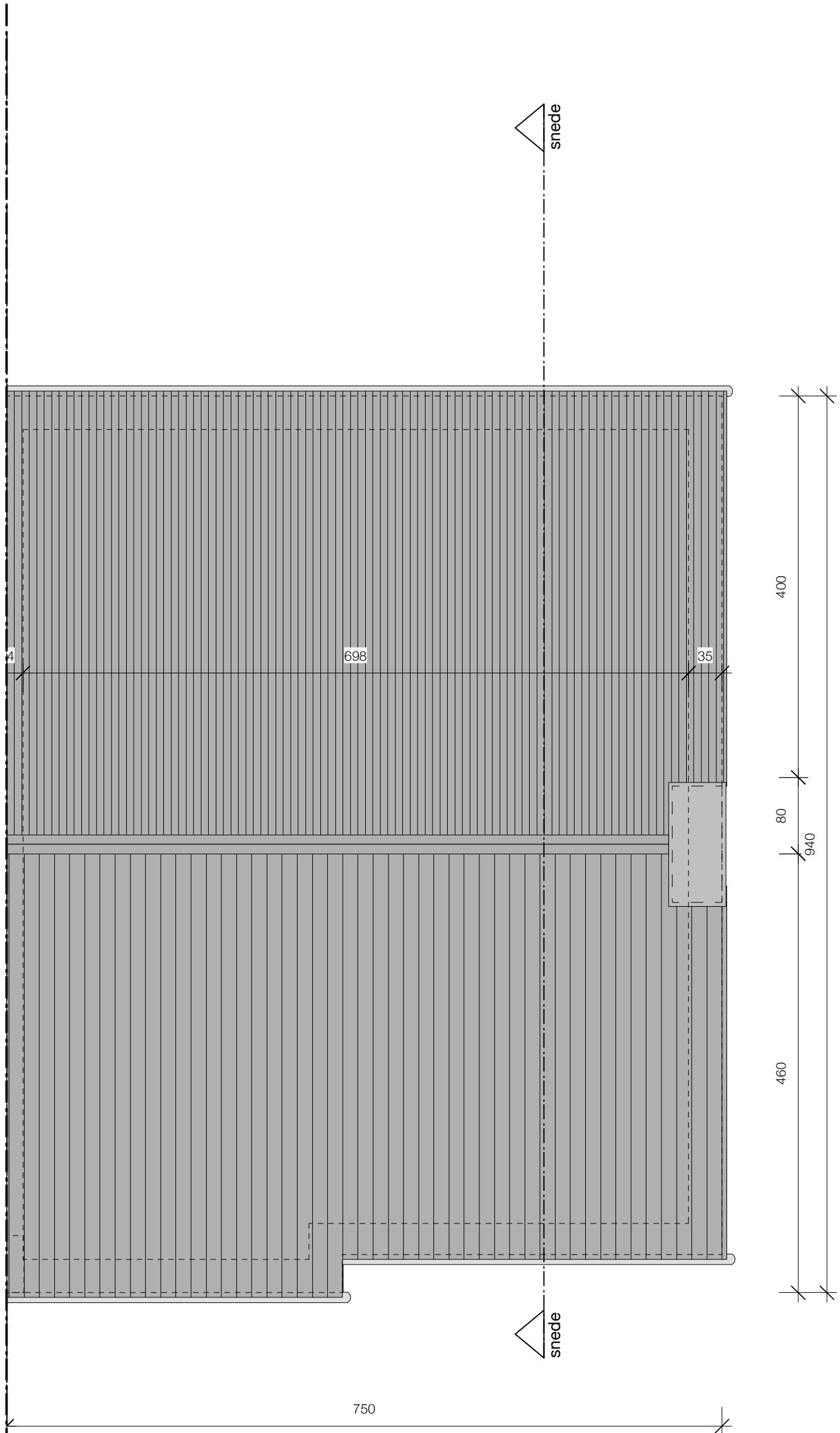

WONING LOT 6

OPP. 149 m²
(80 + 69) (EXCL. ZOLDER)

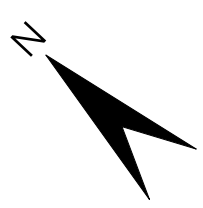

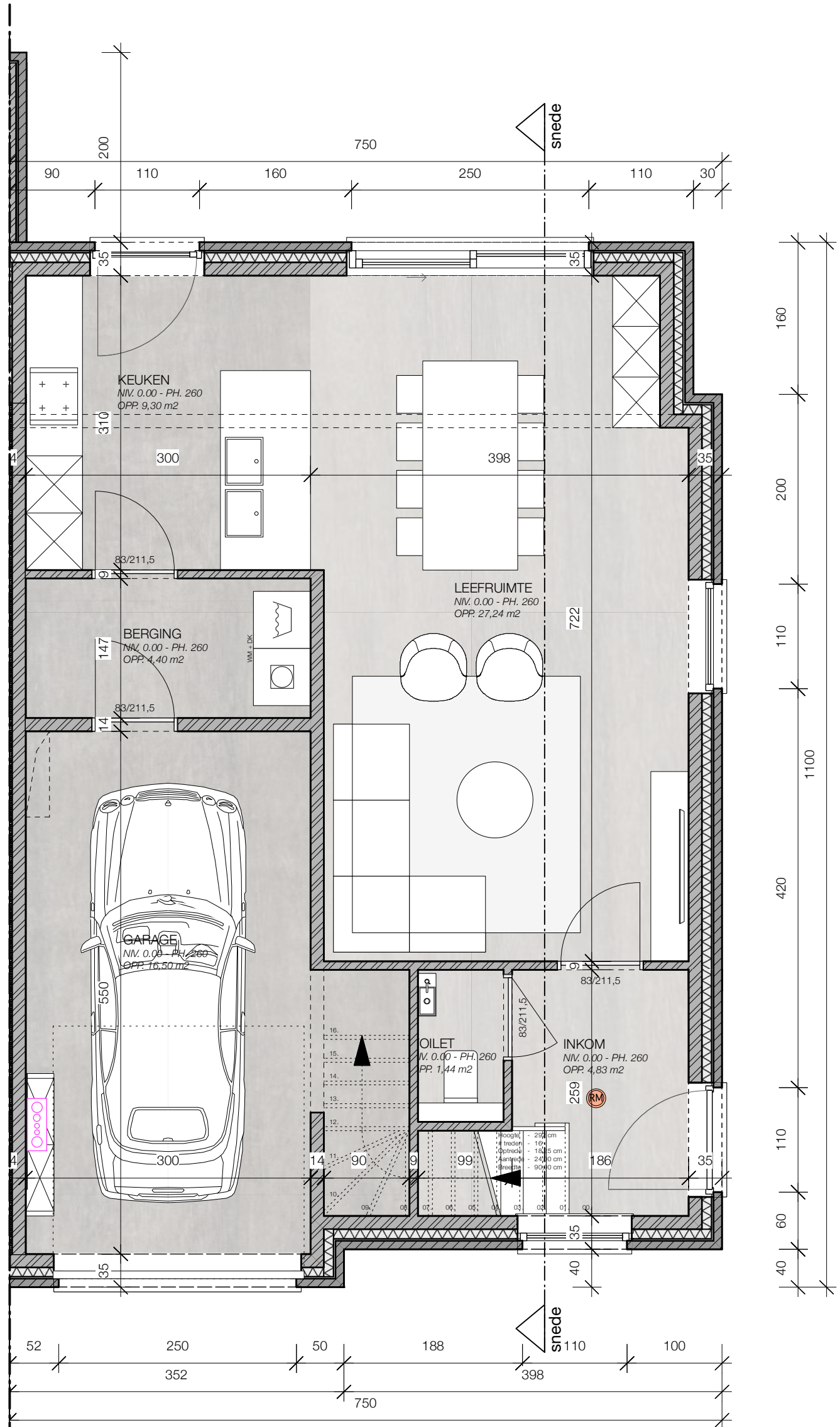

WONING LOT 6

OPP. 149 m²

(80 + 69) (EXCL. ZOLDER)

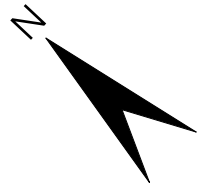

LAURIJSENS ARCHITECTS

lot 6 GELIJKVLOERS
SCHAAL 1/50

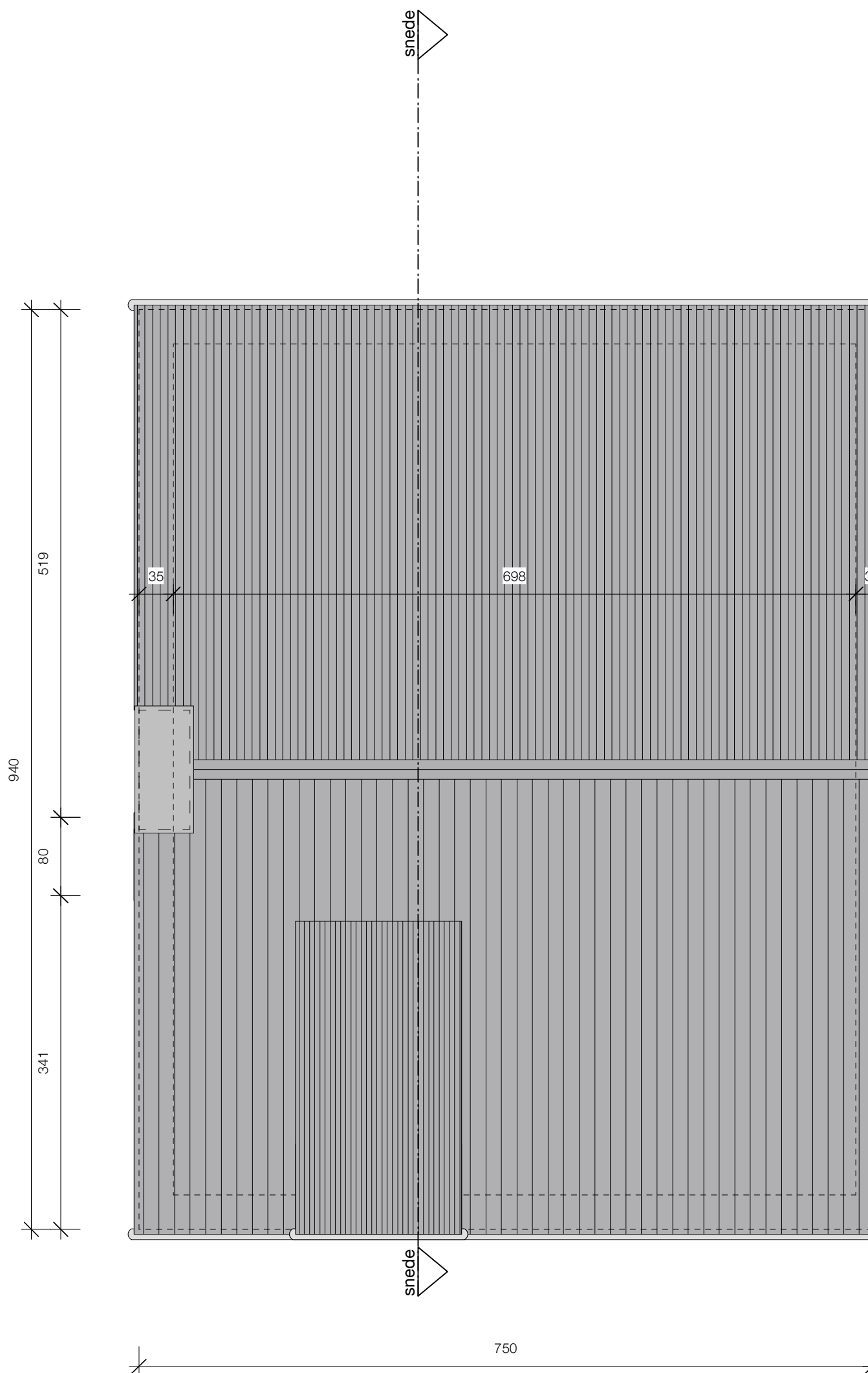

WONING LOT 5

OPP. 141 m²
 (70,5 + 70,5) (EXCL. ZOLDER)

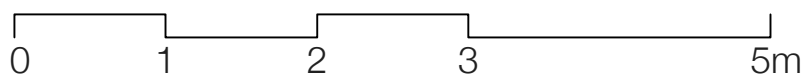
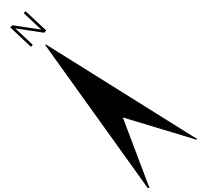

LAURIJSENS ARCHITECTS

lot 5 DAKENPLAN
 SCHAAL 1/50

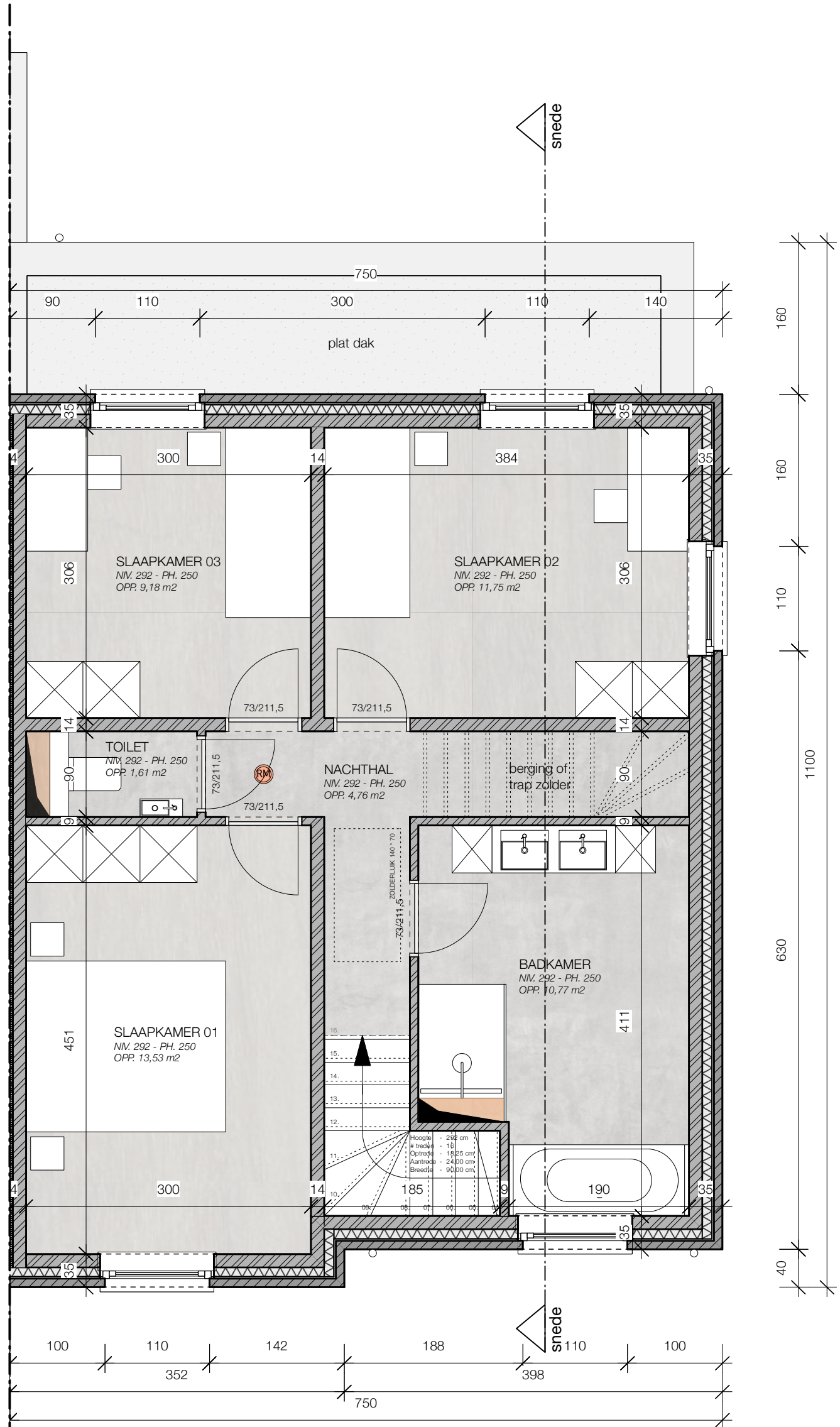

WONING LOT 6

OPP. 149 m²
(80 + 69) (EXCL. ZOLDER)

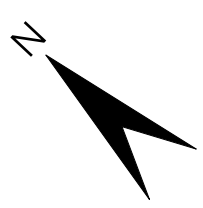

LAURIJSENS ARCHITECTS

lot 6 VERDIEPING
SCHAAL 1/50

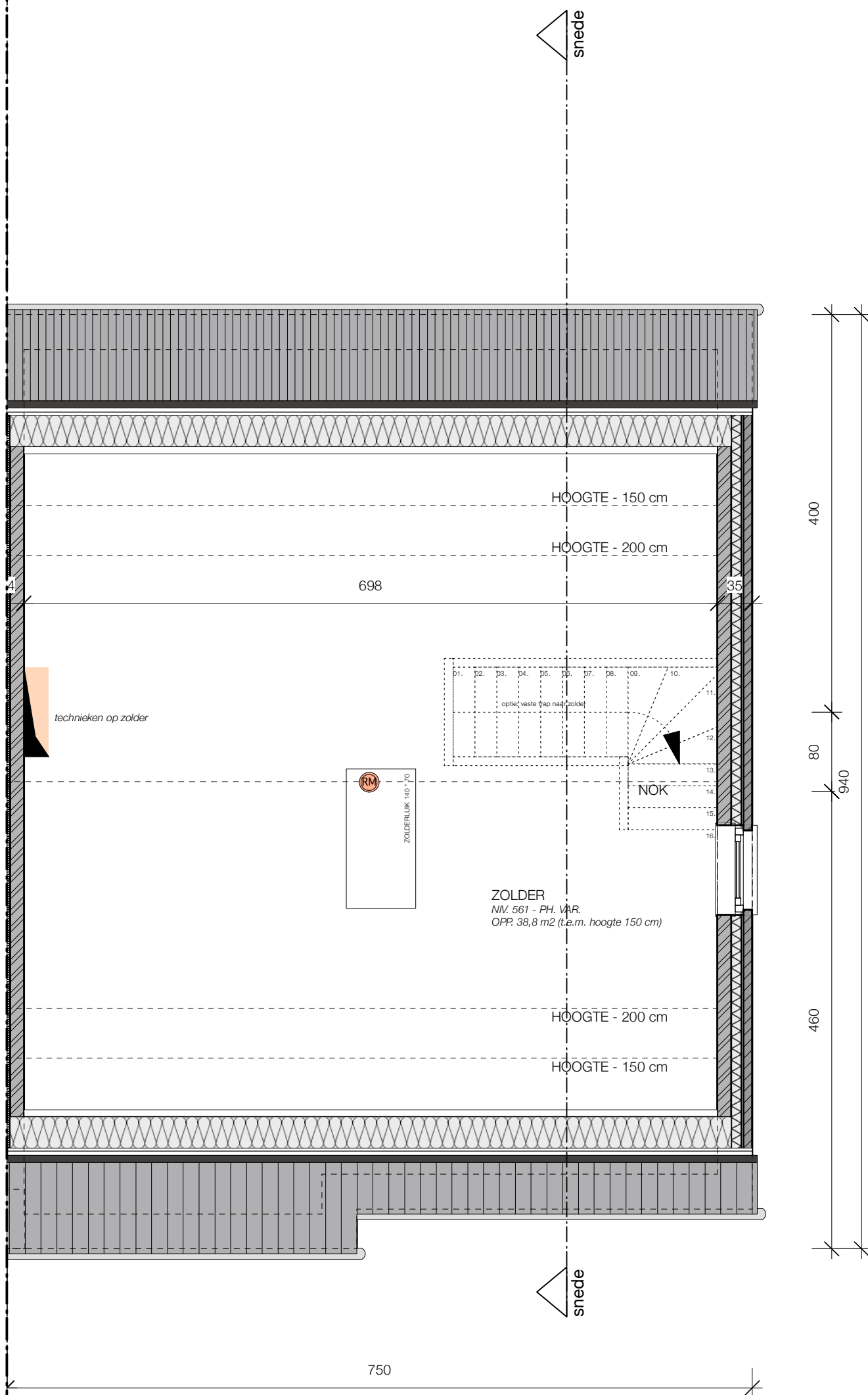

WONING LOT 6

OPP. 149 m²
(80 + 69) (EXCL. ZOLDER)

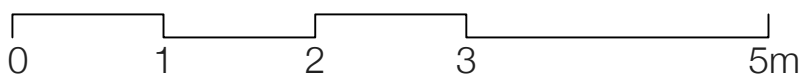
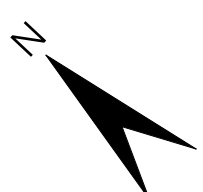

LAURIJSENS ARCHITECTS

lot 6 ZOLDER
SCHAAL 1/50

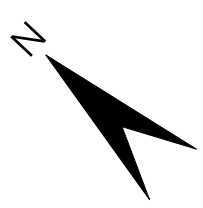
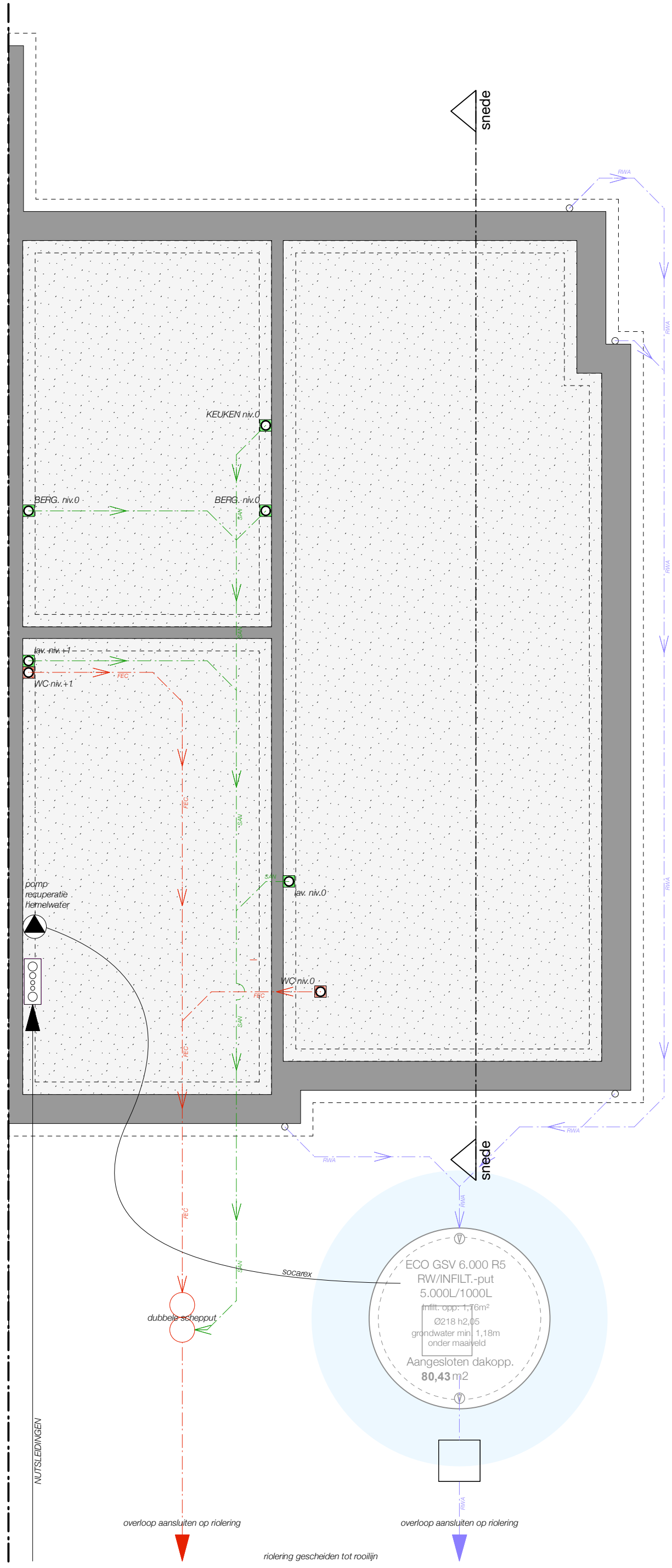

WONING LOT 6



ECO GSV 6.000 R5
 RW/INFILT.-put
 5.000L/1000L
 Inlt. opp. 1,76m²
 Ø218 h2,05
 grondwater min. 1,18m
 onder maaiveld
 Aangesloten dakopp.
 80,43 m²



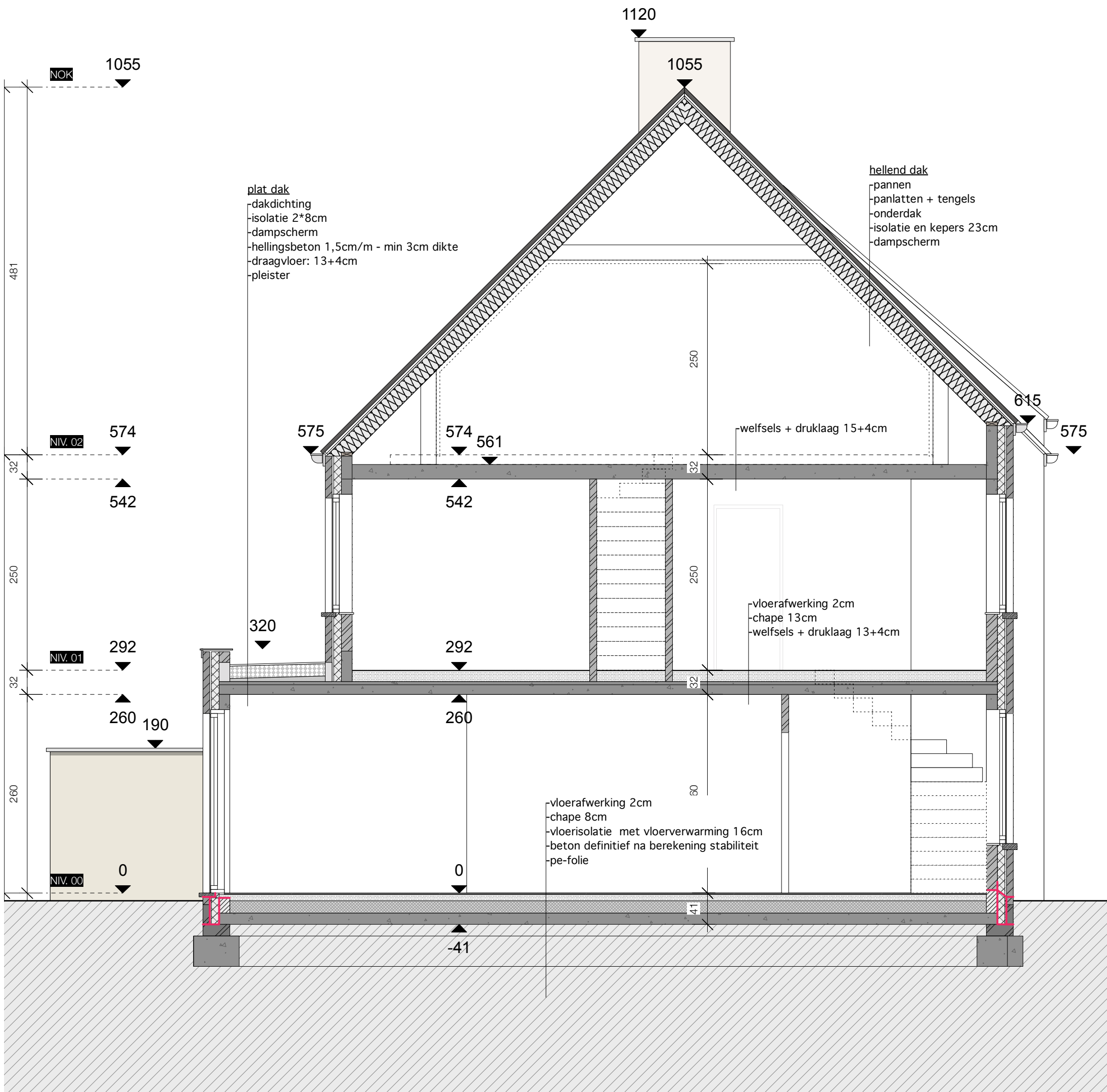

WONING LOT 1

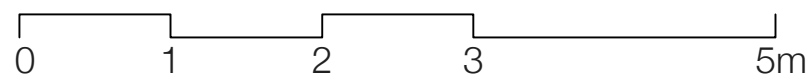

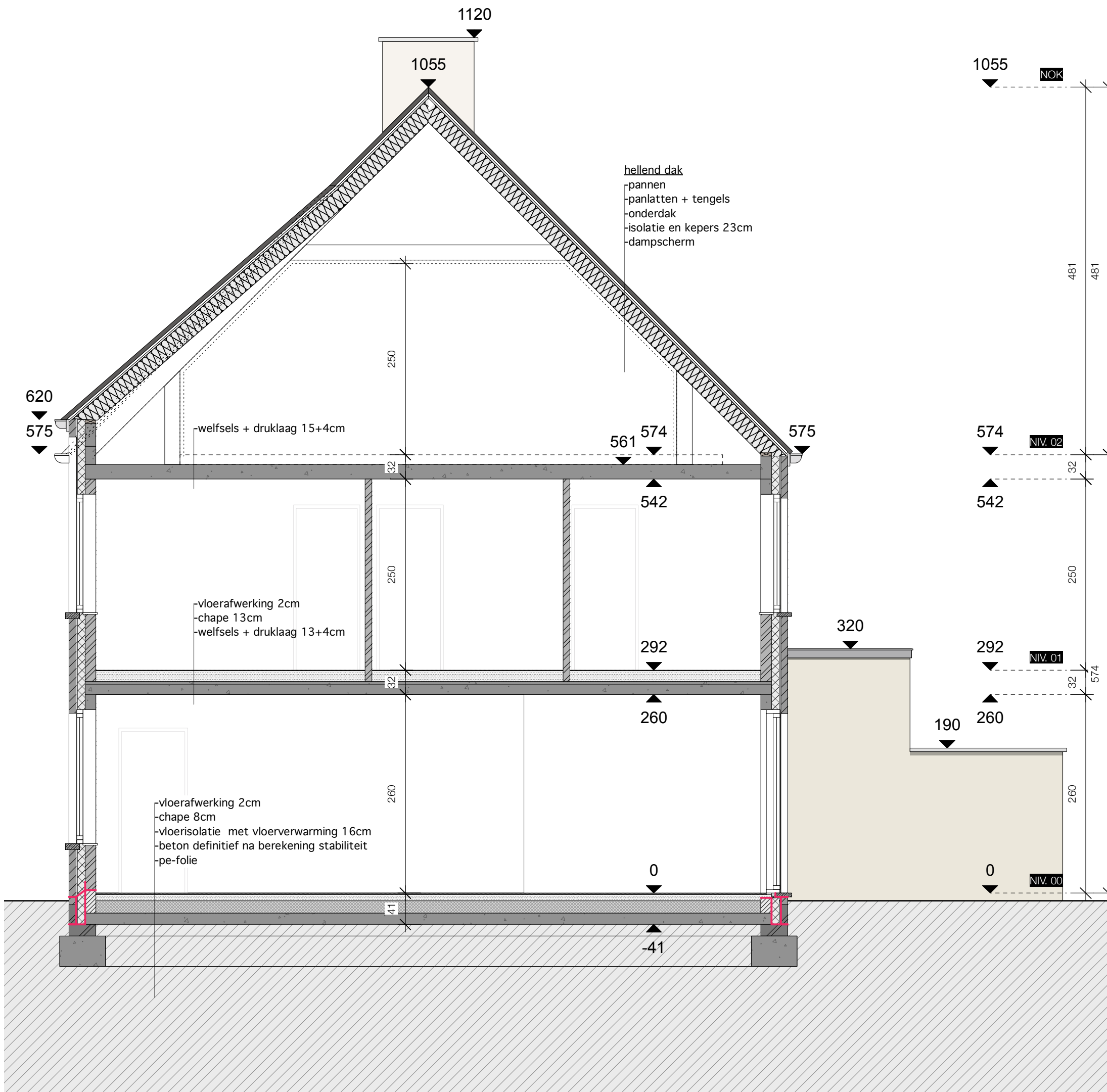

WONING LOT 2

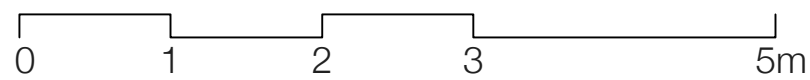

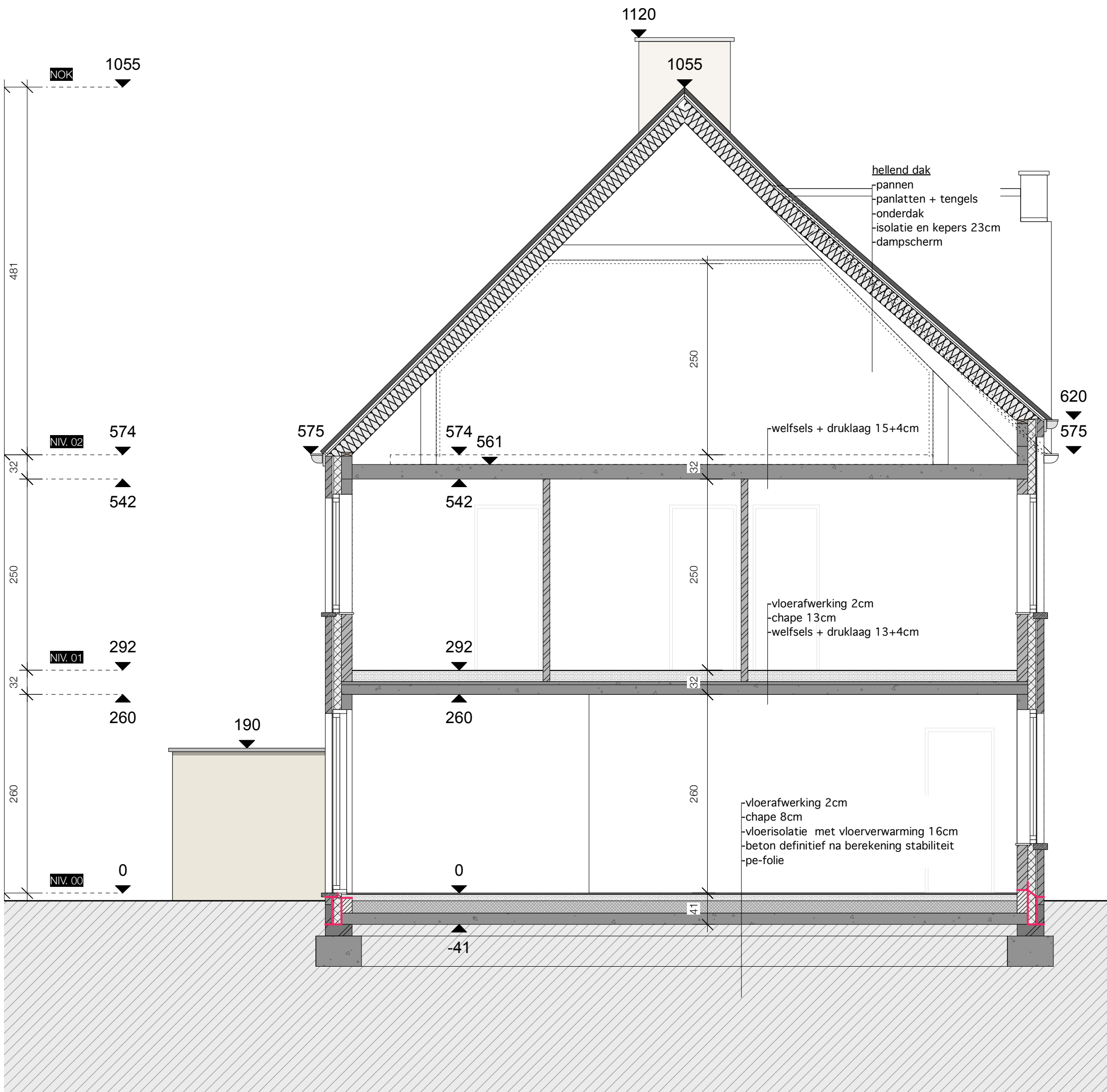

WONING LOT 3

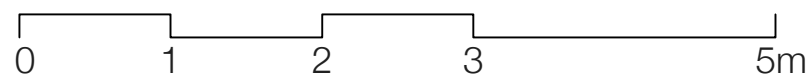

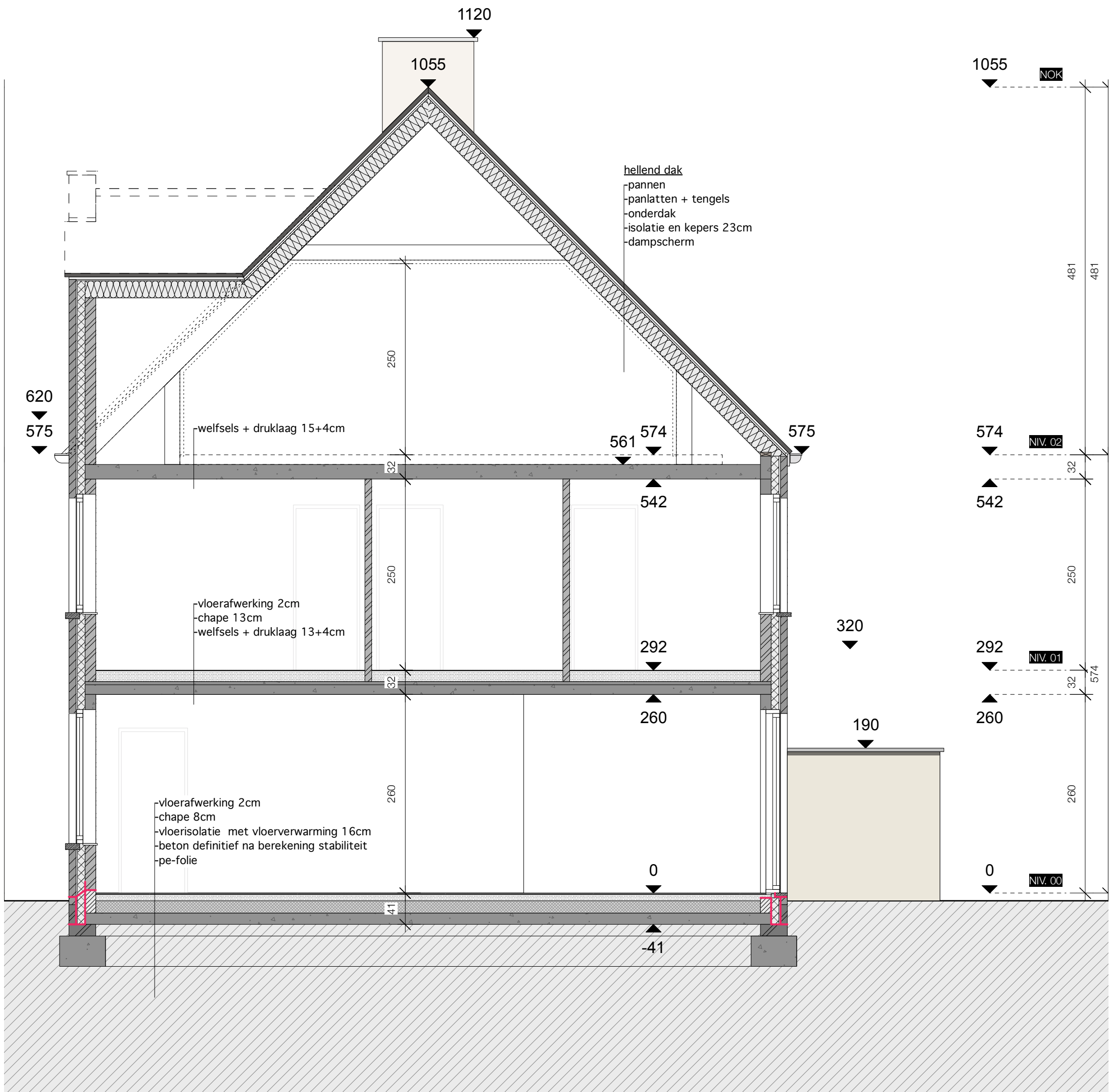

WONING LOT 4

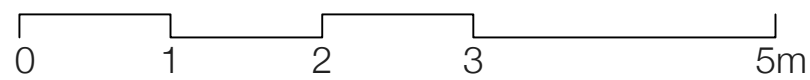

LAURIJSENS ARCHITECTS

lot 4 DOORSNEDE
 SCHAAL 1/50

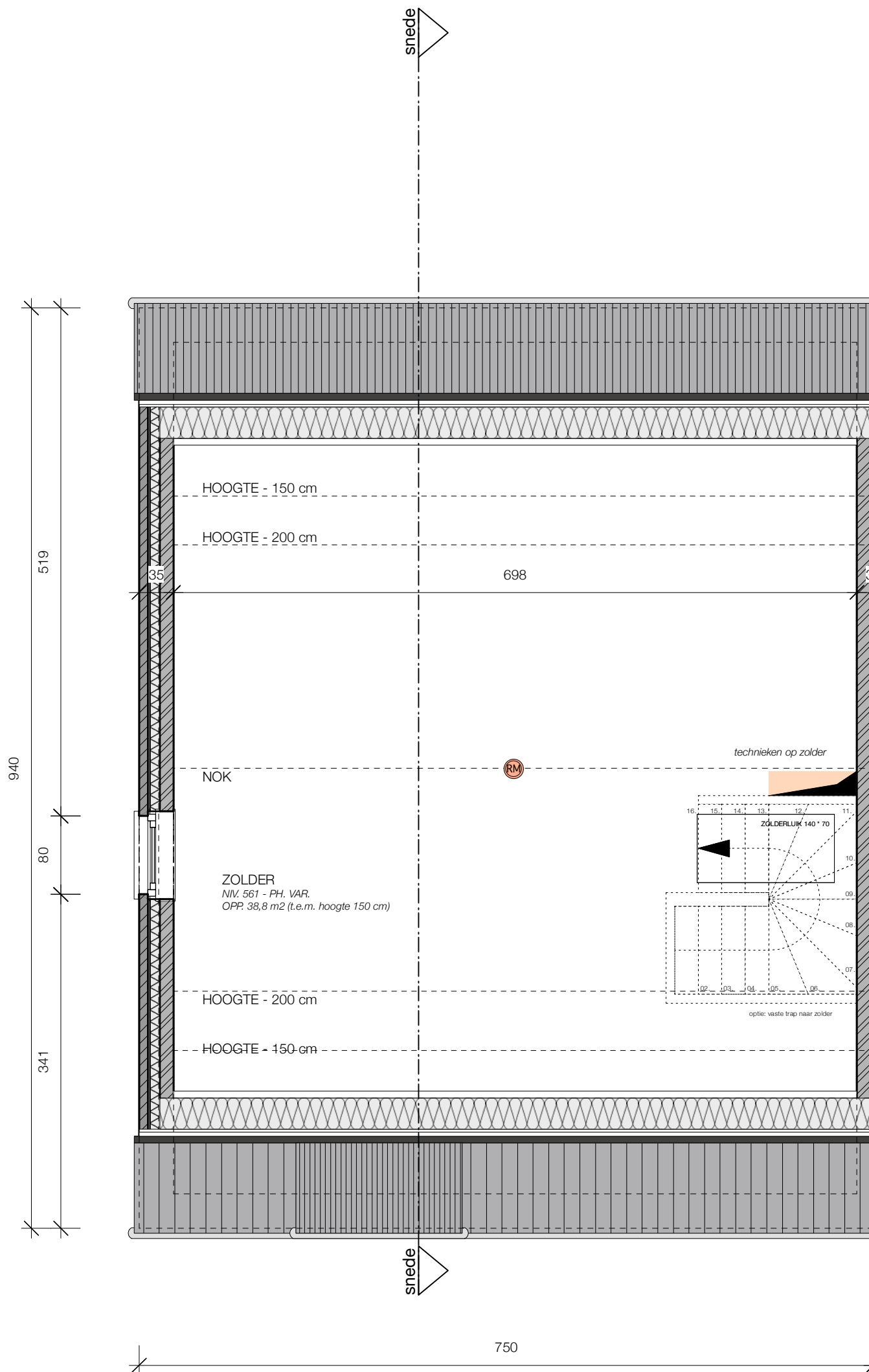

WONING LOT 5

OPP. 141 m²
(70,5 + 70,5) (EXCL. ZOLDER)

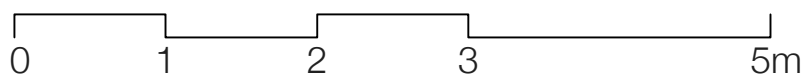
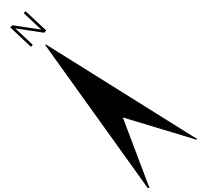

LAURIJSENS ARCHITECTS

lot 5 ZOLDER
SCHAAL 1/50

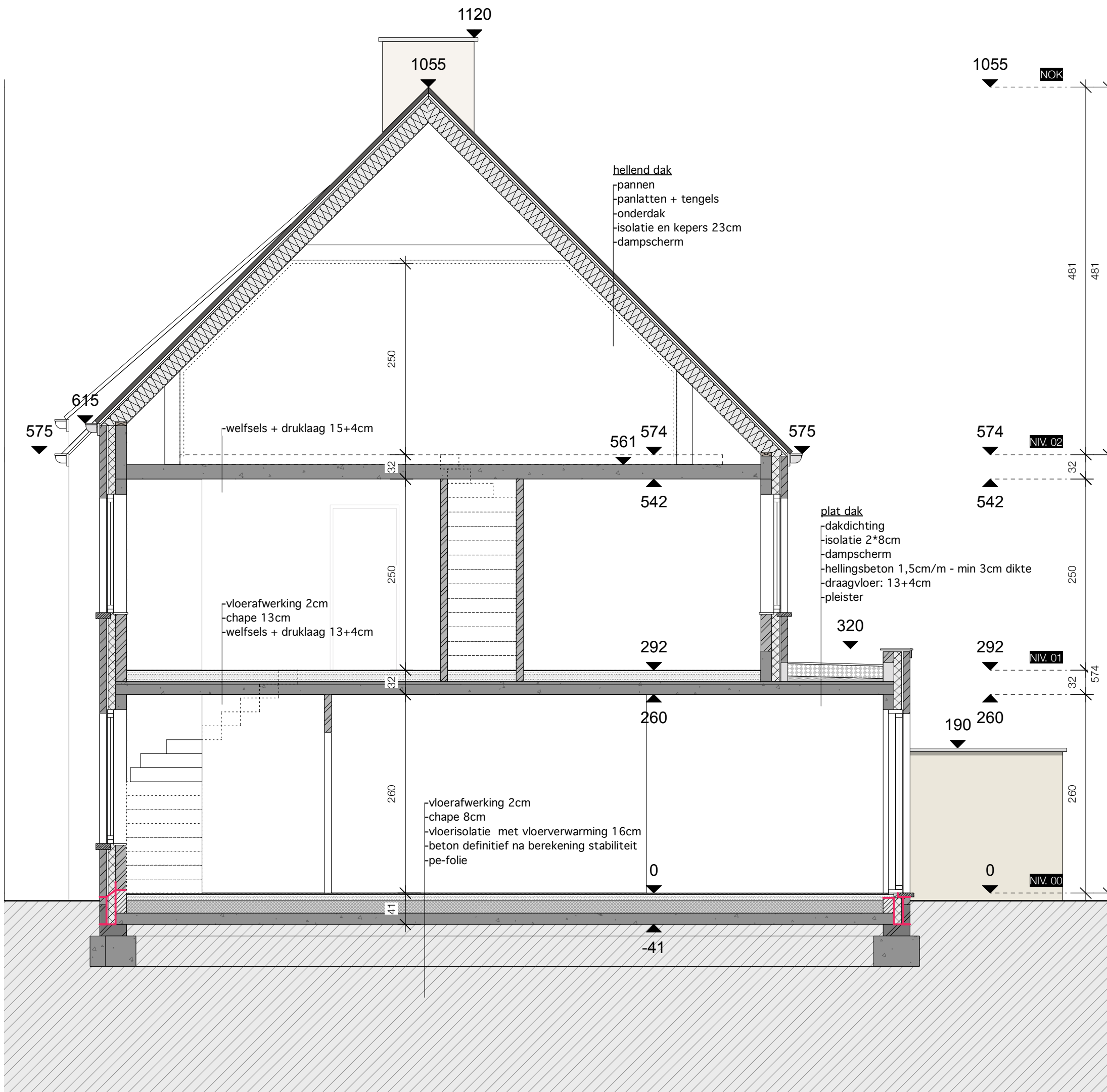

WONING LOT 6

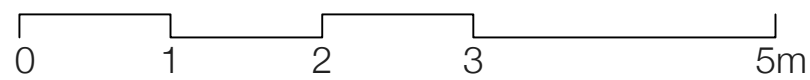

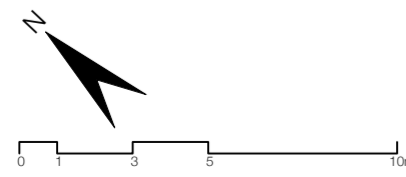

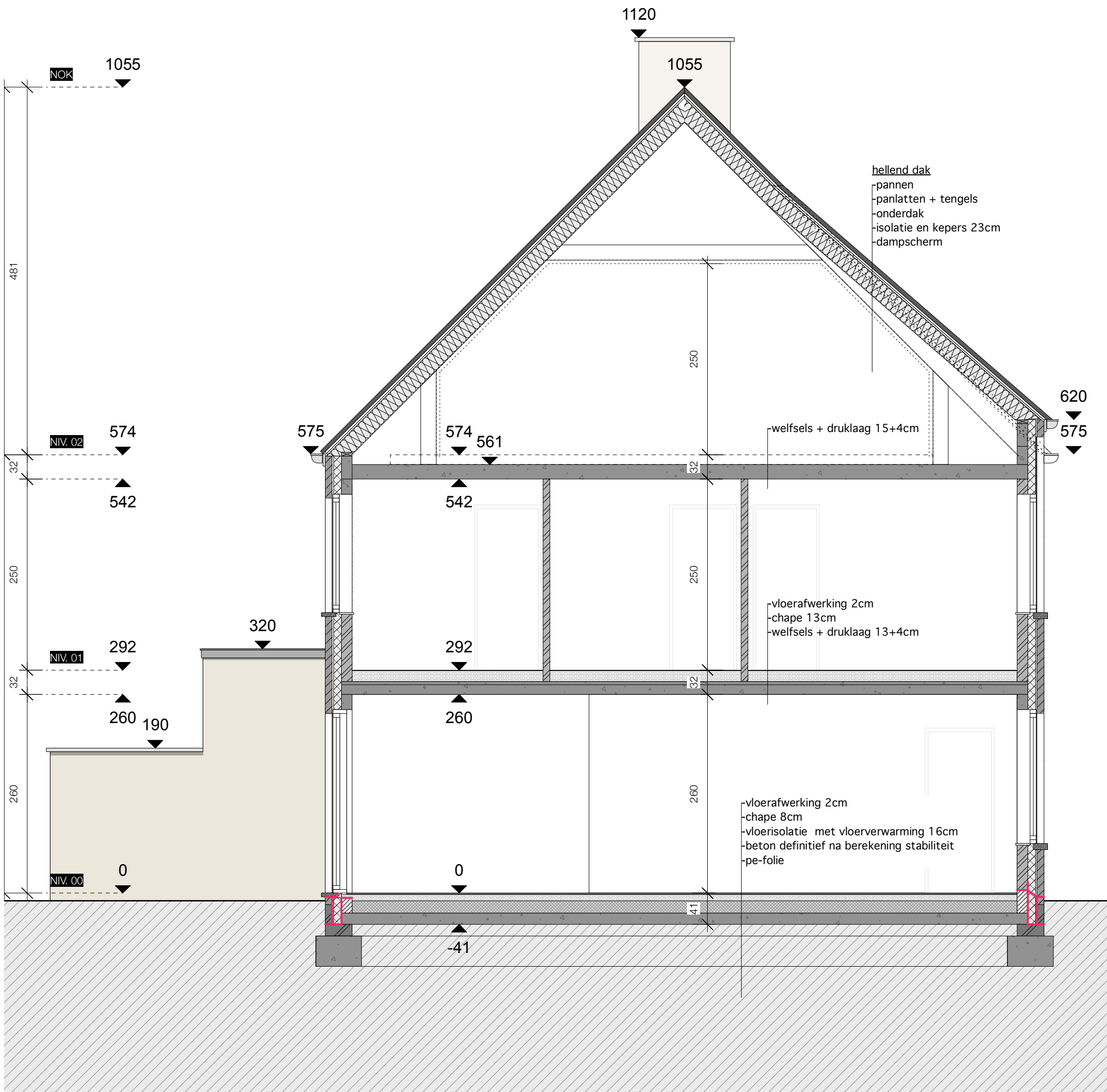

WONING LOT 5

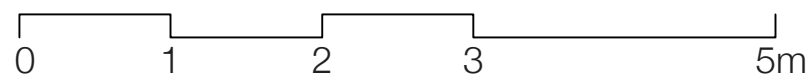

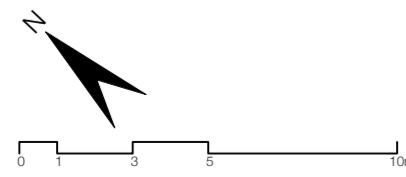
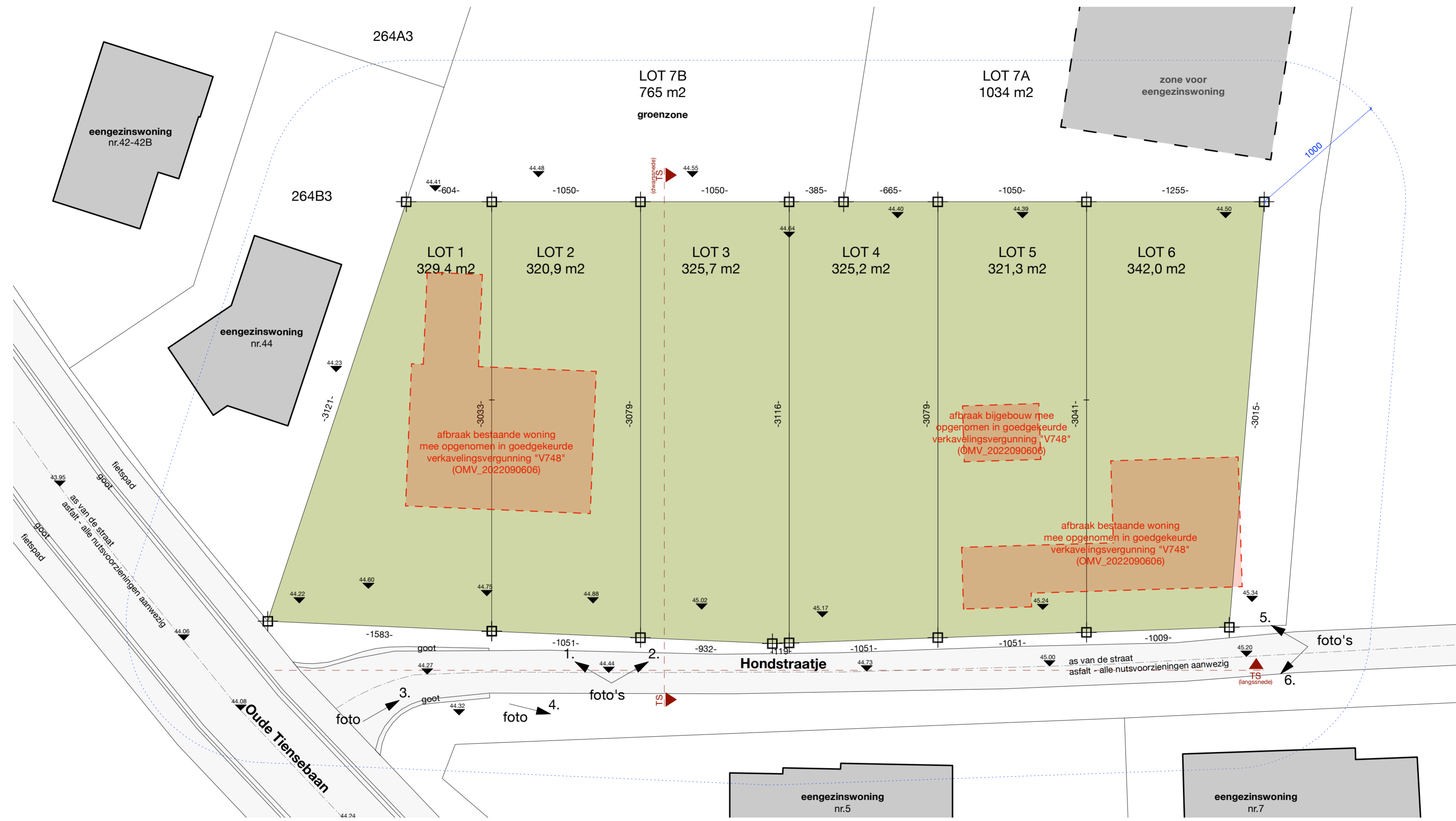

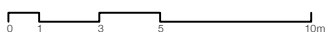
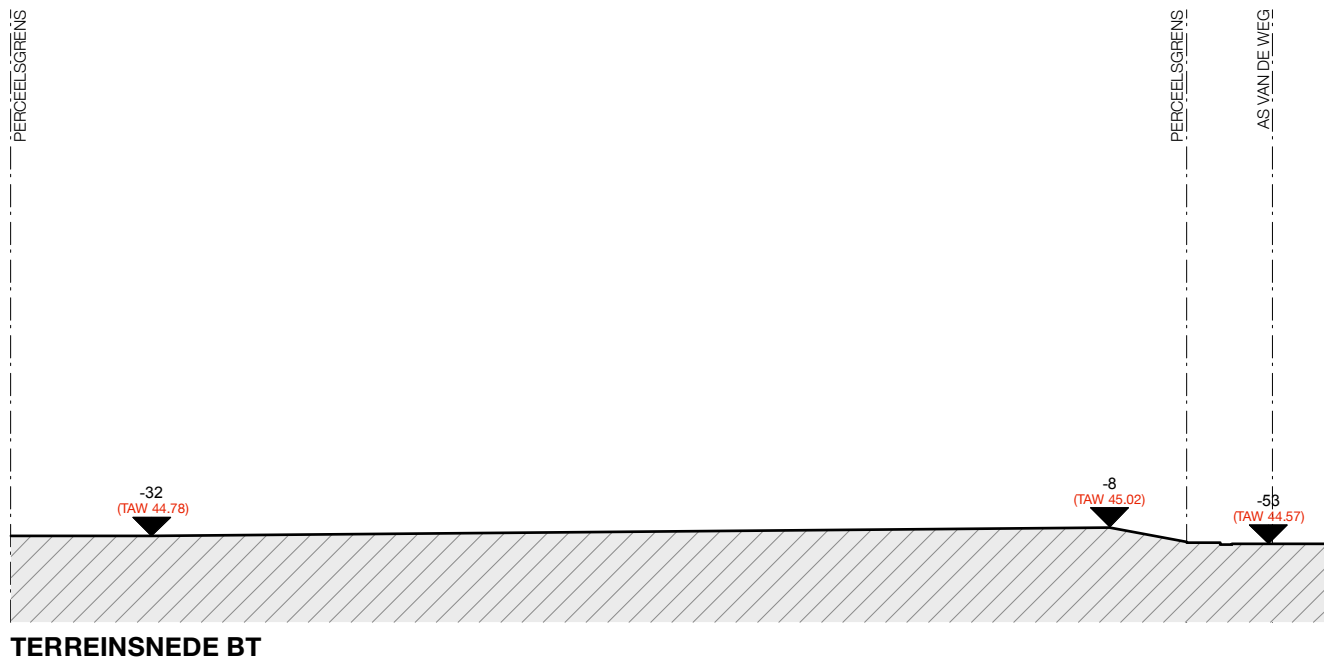

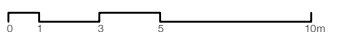

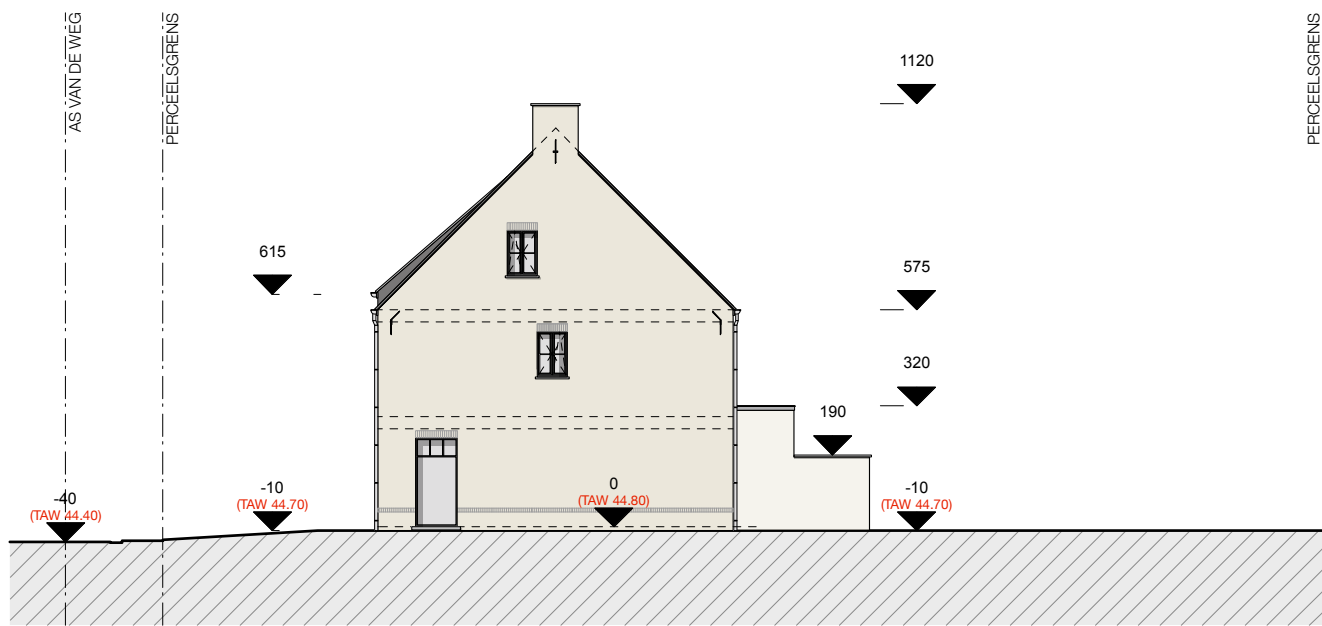

WONING LOT 2

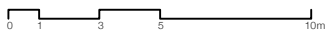

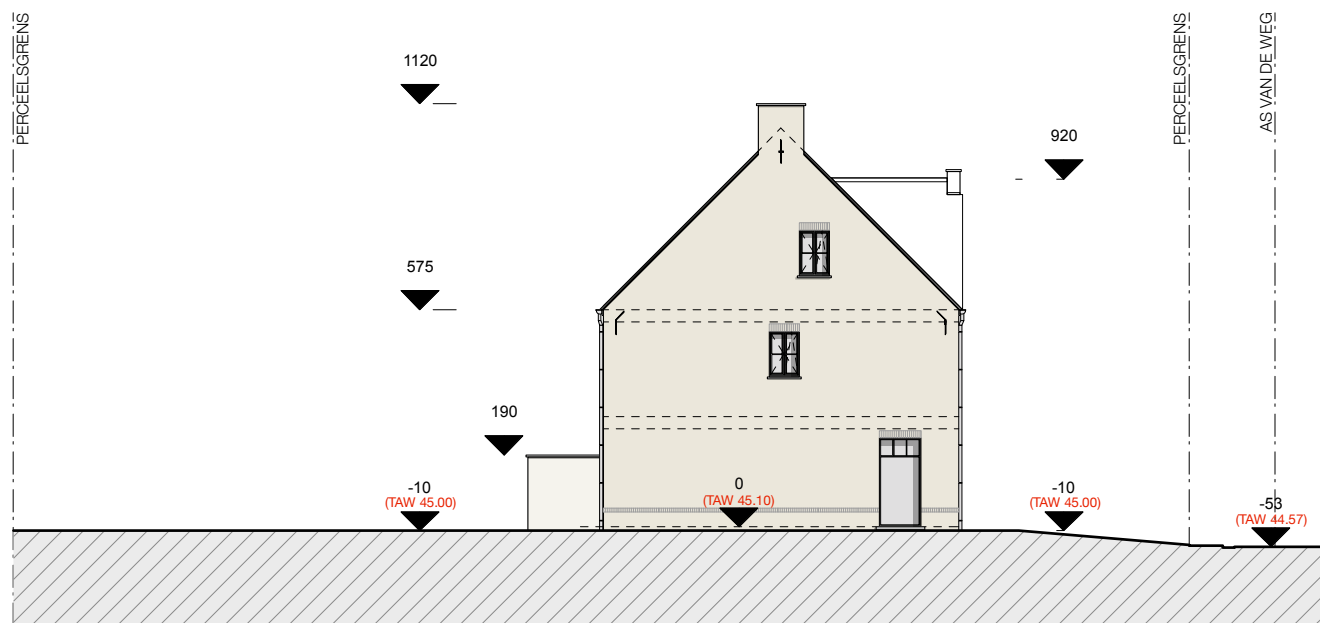

WONING LOT 3

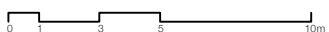

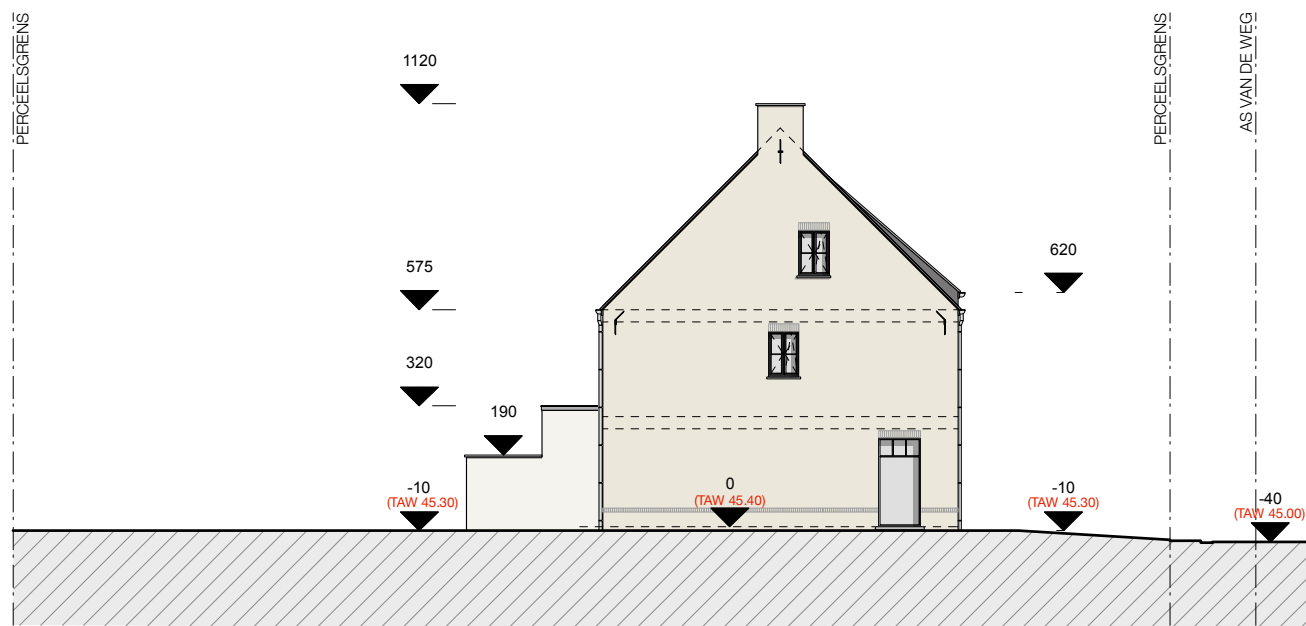

WONING LOT 5

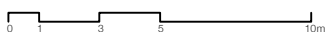

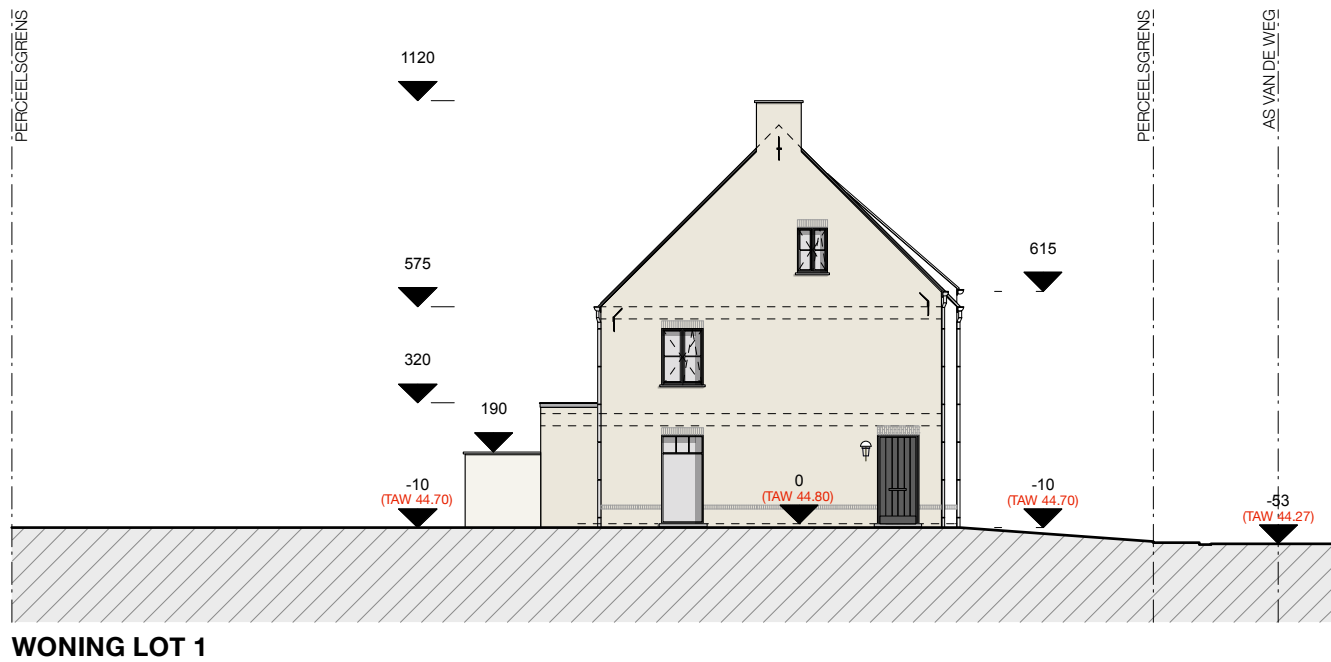

WONING LOT 1

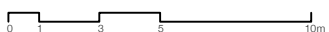

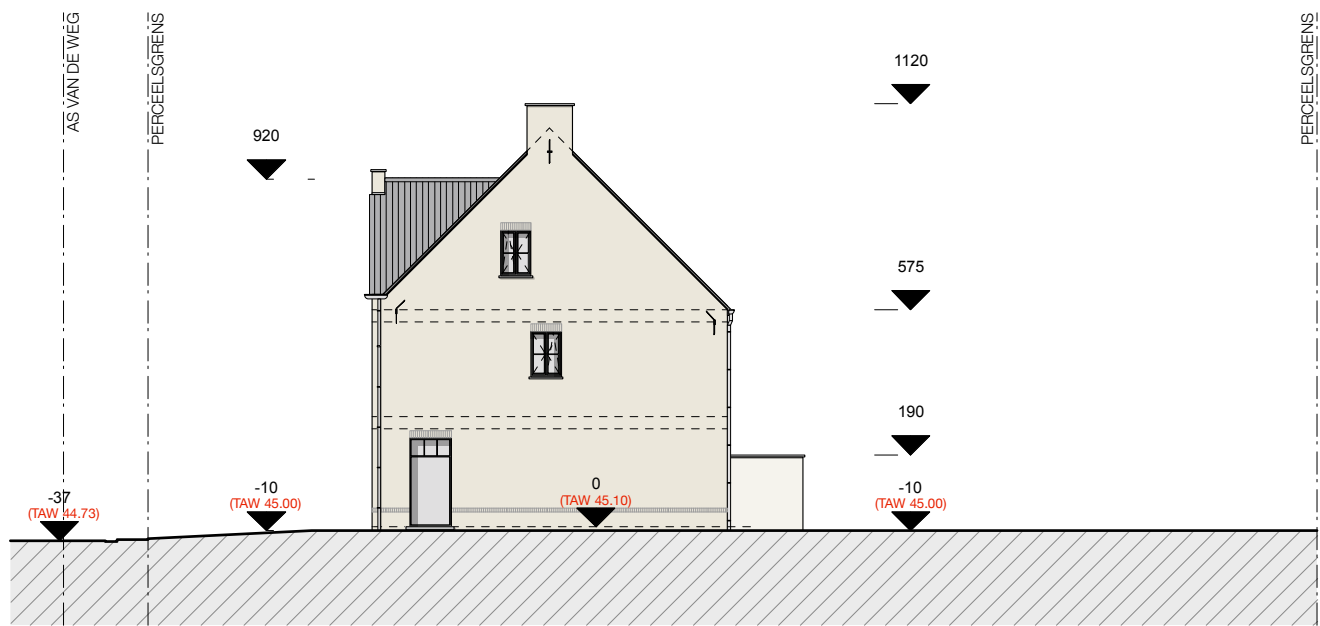

WONING LOT 4

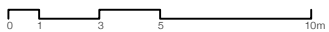

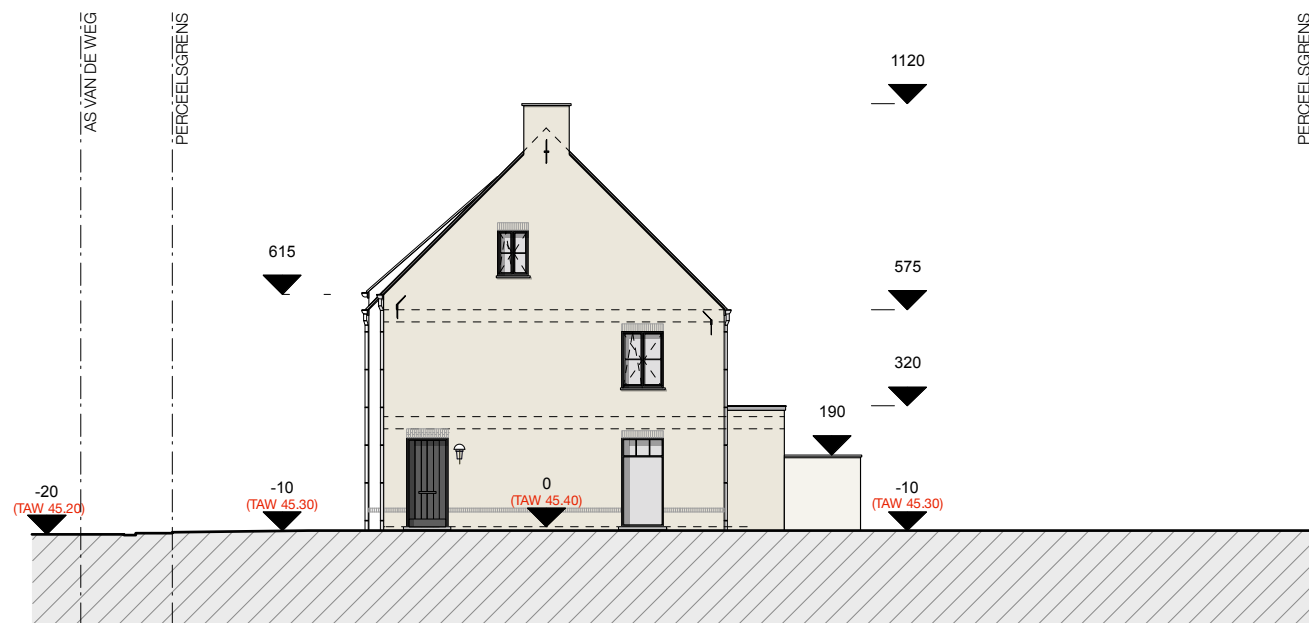

WONING LOT 6

