

■ **NORMATIVA DE USO**
CONDITIONS OF USE

UNE EN1069-1-2:2010-5-10-4965

Body Slide
Año 2019

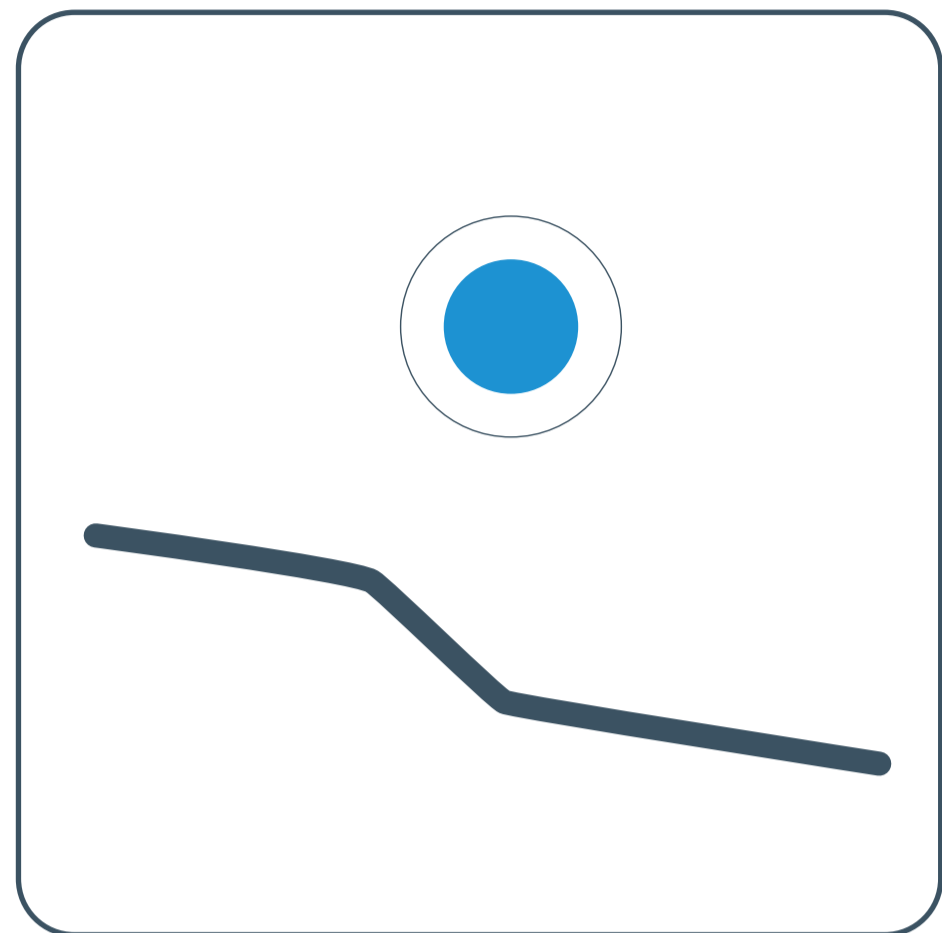

RECORRIDO FÁCIL
EASY RIDE



ALTURA MÍNIMA
MINIMUM HEIGHT

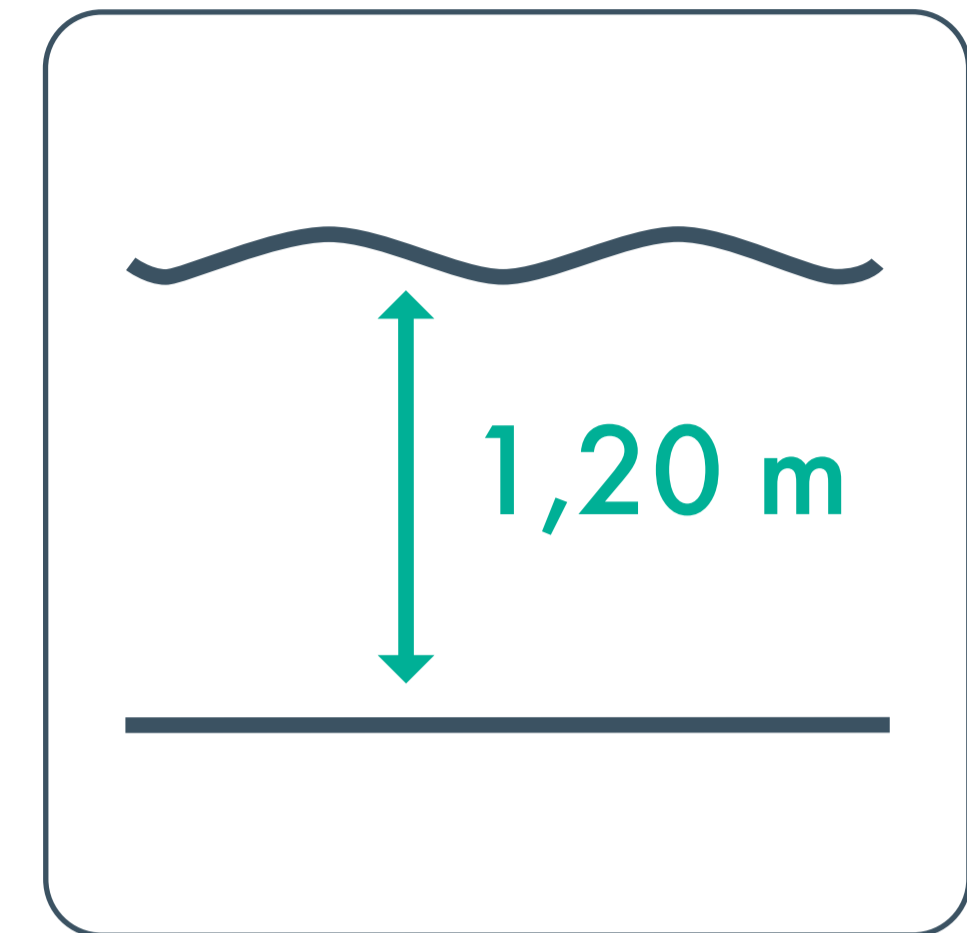

PROFUNDIDAD PISCINA
POOL DEPTH

DESLIZARSE INDIVIDUALMENTE.
ACOSTADO. MANTENER PIES Y
MANOS DENTRO DEL TOBOGÁN
SLIDE DOWN ON YOUR OWN, LYING ON YOUR
BACK. KEEP HANDS AND FEET INSIDE THE SLIDE.



DESPEJAR INMEDIATAMENTE
LA ZONA DE RECEPCIÓN
CLEAR THE LANDIND AREA IMMEDIATELY

ISABA
play your difference

ISABA PROJECTS, S.A.
C/Argenters 19
Alcácer - VALENCIA

■ **NORMATIVA DE USO**

CONDITIONS OF USE

UNE EN1069-1-2:2010-5-10-4965

Freefall

Año 2019

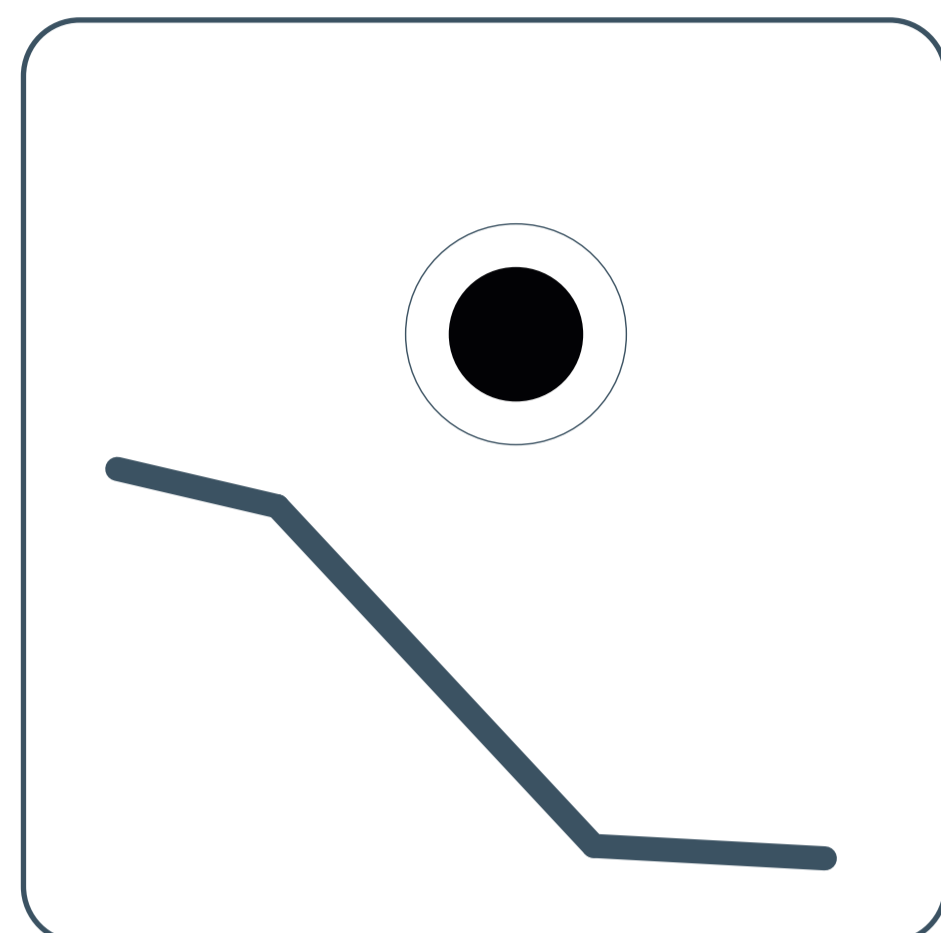

RECORRIDO DIFÍCIL

SEVERE RIDE



ALTURA MÍNIMA

MINIMUM HEIGHT

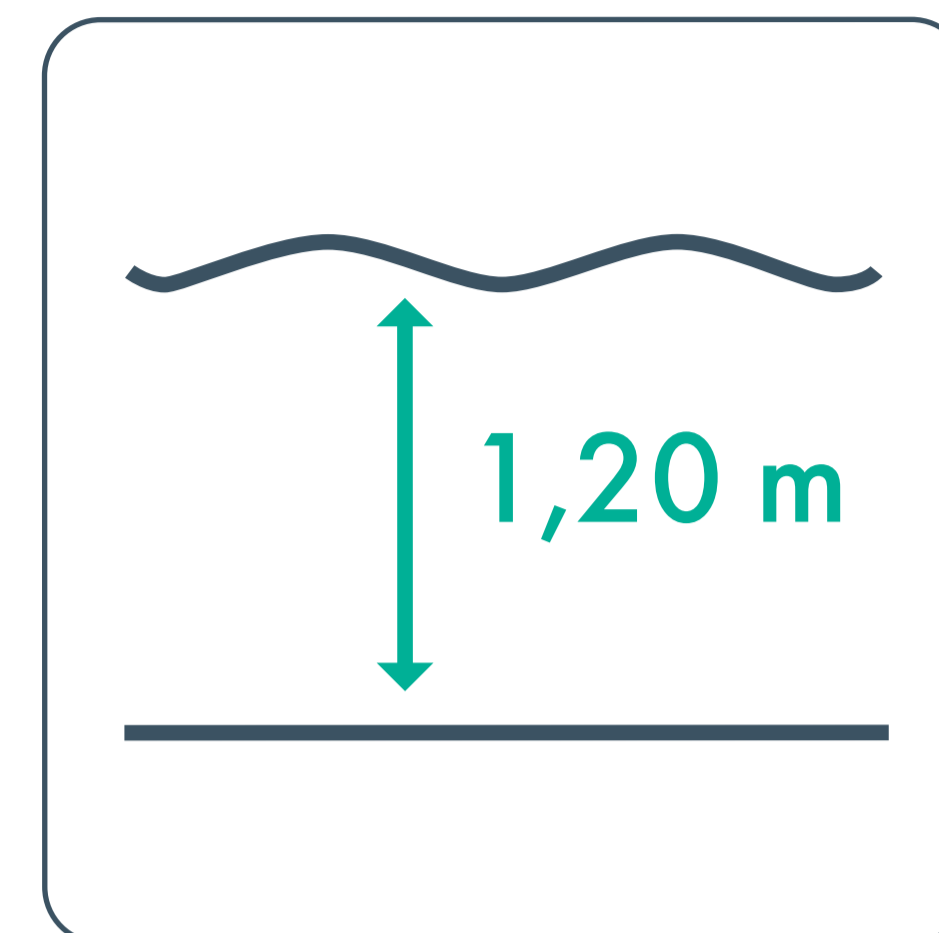

PROFUNDIDAD PISCINA

POOL DEPTH

**DESLIZARSE INDIVIDUALMENTE.
ACOSTADO. MANTENER PIES Y
MANOS DENTRO DEL TOBOGÁN**
**SLIDE DOWN ON YOUR OWN, LYING ON YOUR
BACK. KEEP HANDS AND FEET INSIDE THE SLIDE.**

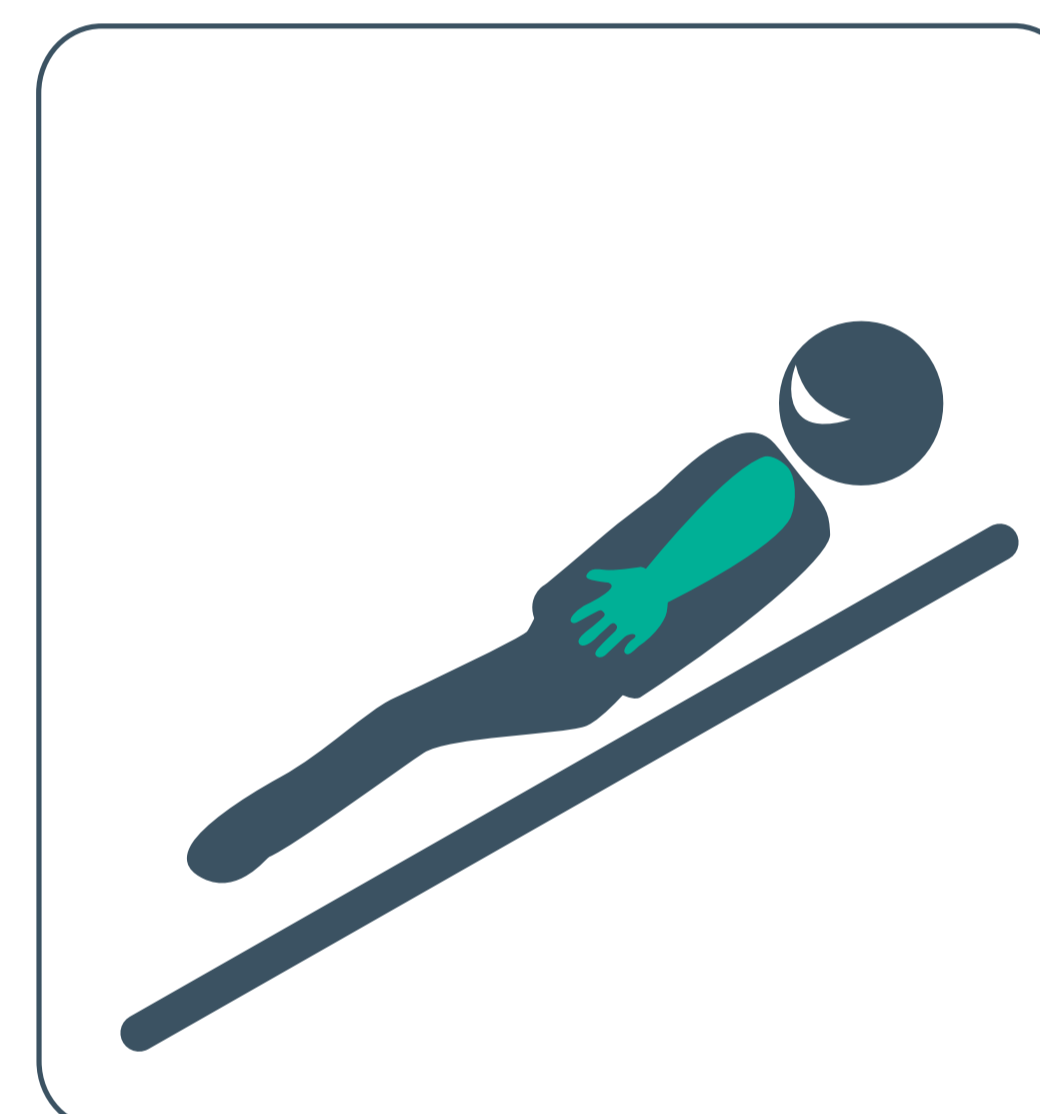

**DESPEJAR INMEDIATAMENTE
LA ZONA DE RECEPCIÓN**

CLEAR THE LANDING AREA IMMEDIATELY

ISABA
play your difference

ISABA PROJECTS, S.A.

C/Argenters 19

Alcácer - VALENCIA

■ **NORMATIVA DE USO**
CONDITIONS OF USE
UNE EN1069-1-2:2010-5-10-49 65

Wide Slide
Año 2019

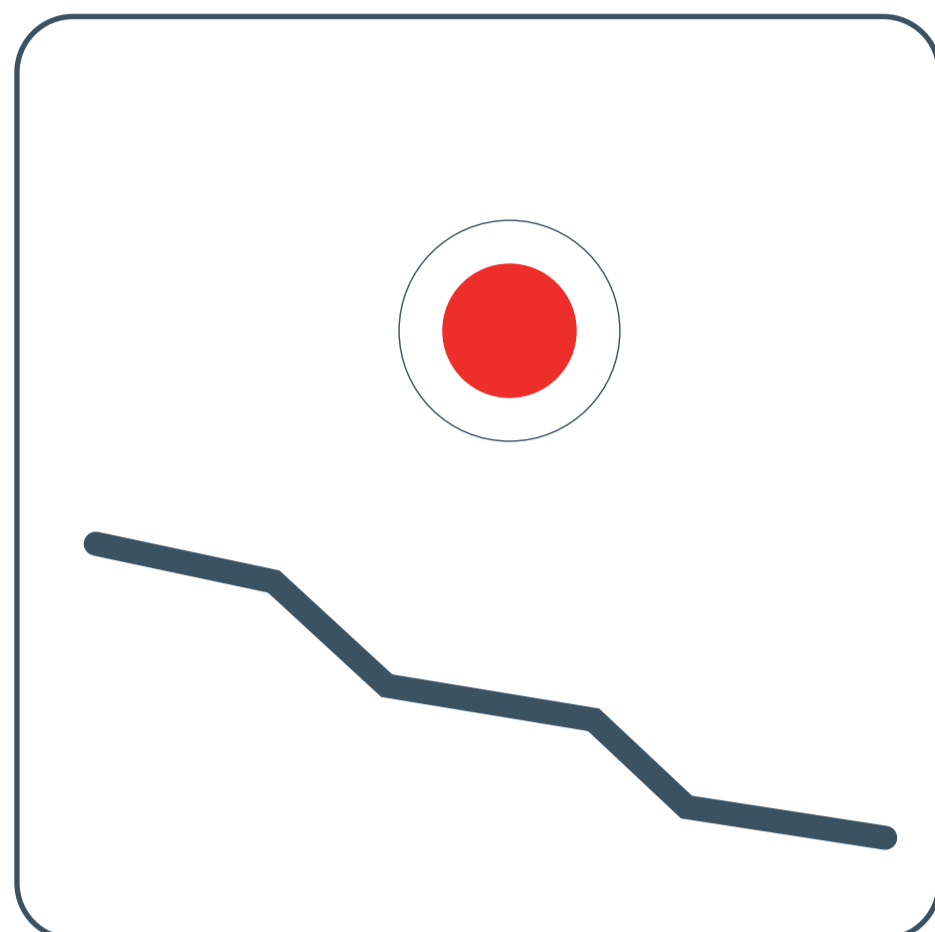

DIFICULTAD MEDIA
MEDIUM CHALLENGE



ALTURA MÍNIMA
MINIMUM HEIGHT

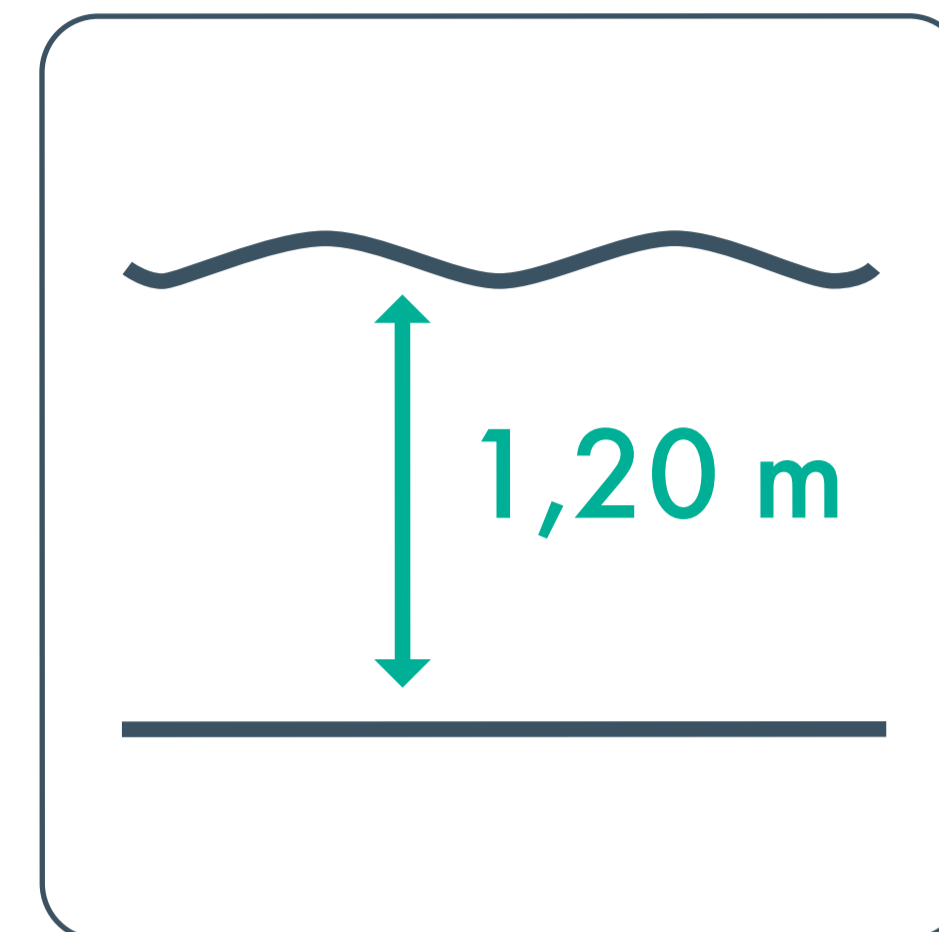

PROFUNDIDAD PISCINA
POOL DEPTH

DESLIZARSE INDIVIDUALMENTE.
ACOSTADO. MANTENER PIES Y
MANOS DENTRO DEL TOBOGÁN
SLIDE DOWN ON YOUR OWN, LYING ON YOUR
BACK. KEEP HANDS AND FEET INSIDE THE SLIDE.



DESPEJAR INMEDIATAMENTE
LA ZONA DE RECEPCIÓN
CLEAR THE LANDIND AREA IMMEDIATELY

ISABA
play your difference

ISABA PROJECTS, S.A.
C/Argenters 19
Alcácer - VALENCIA

NORMATIVA DE APLICACIÓN
REGULATIONS OF APPLICATION

UNE EN 1069-1:2017
Año 2019

TIPOS DE TOBOGÁN
SLIDE TYPE

TUB 944 - TUB 896 - AQUARIVER

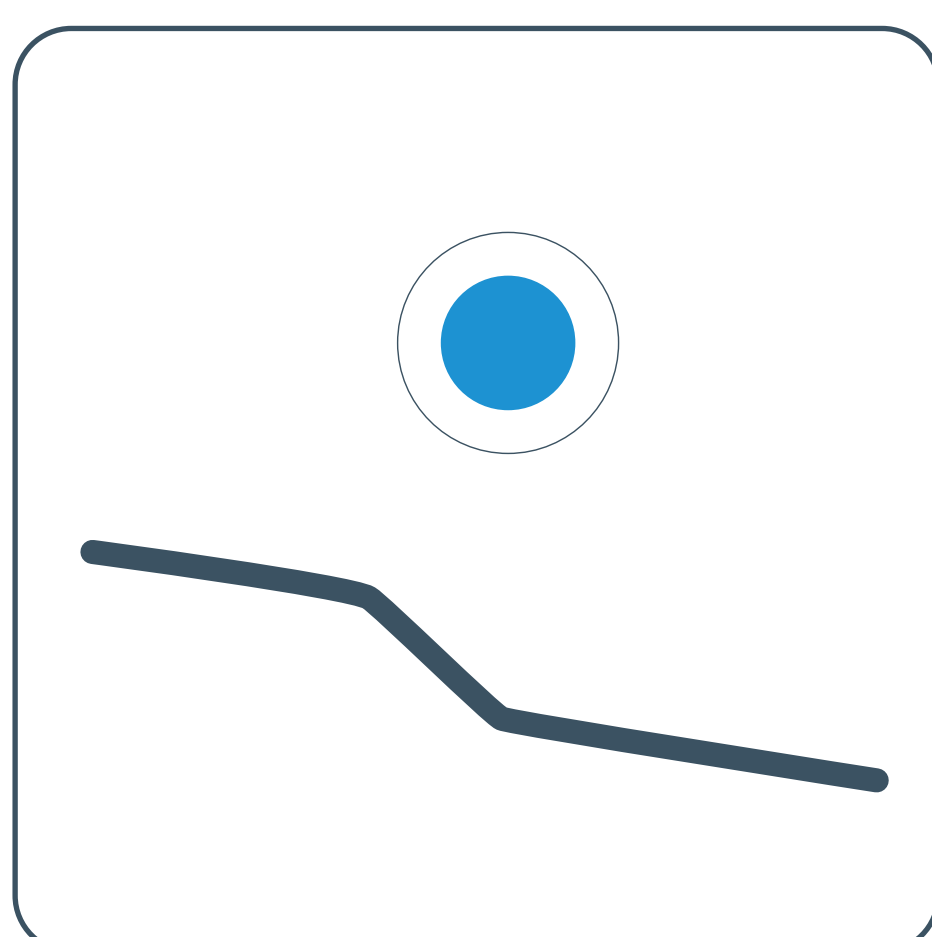

FÁCIL RECORRIDO
EASY RIDE

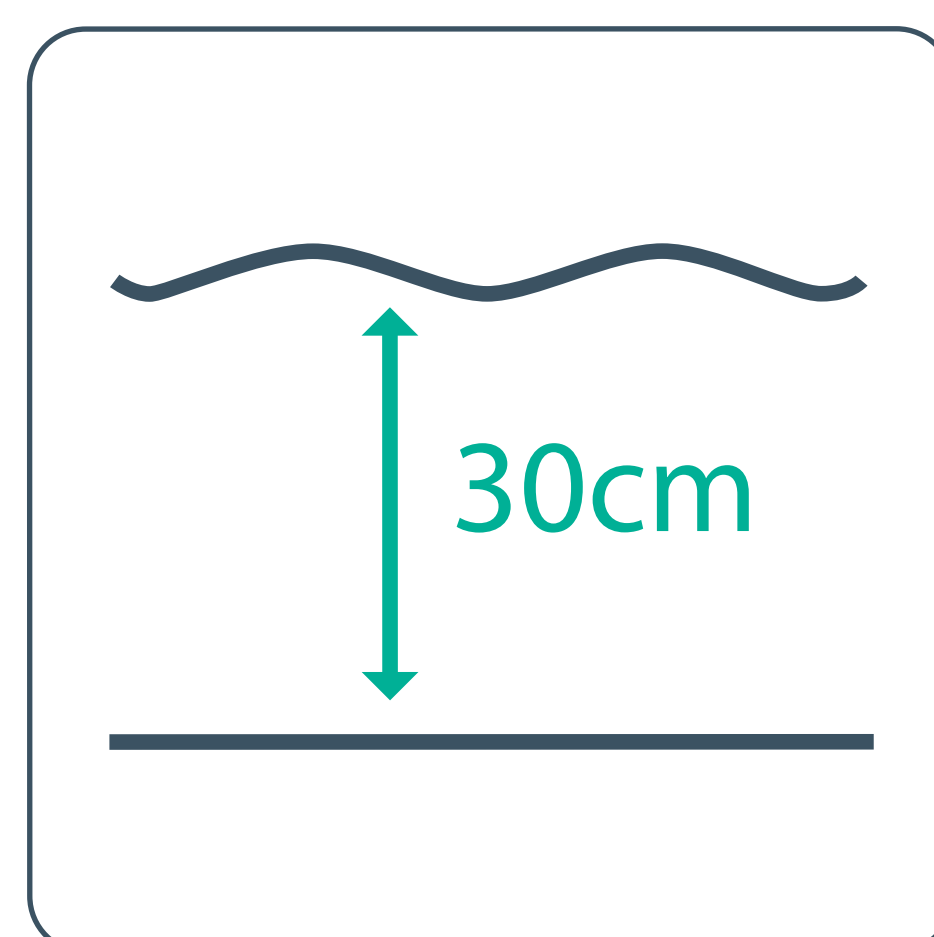

PROFUNDIDAD PISCINA
POOL DEPTH



ALTURA MÍNIMA 0.80m
MINIMUM HEIGHT 0.80m



DESPEJAR INMEDIATAMENTE LA ZONA DE RECEPCIÓN
CLEAR THE LANDING AREA IMMEDIATELY

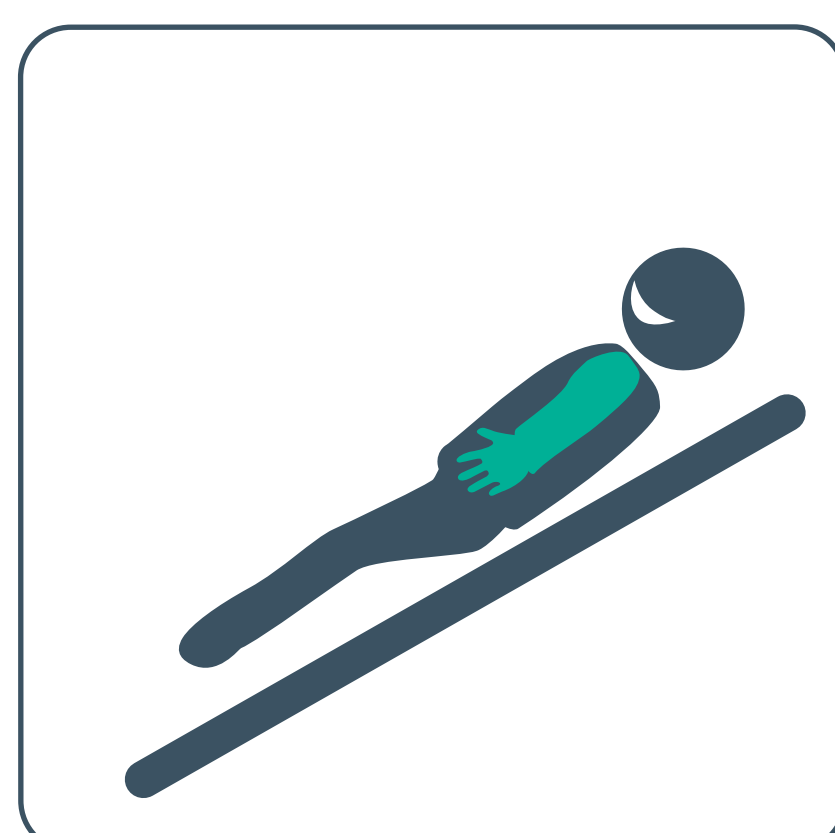

DESLIZARSE INDIVIDUALMENTE. SÓLO ACOSTADO.
MANTENER PIES Y MANOS DENTRO DEL TOBOGÁN.
SLIDE DOWN ON YOUR OWN. SLIDE LYING ON
YOUR BACK. KEEP YOUR HANDS AND FEET INSIDE THE SLIDE.

ISABA
play your difference

ISABA PROJECTS, S.A.
C/Argenters 19
Alcàsser - VALÈNCIA
PY19-008