

1

2

3

4

DWG NO

SH

REV

6

REVISIONS

CREATION

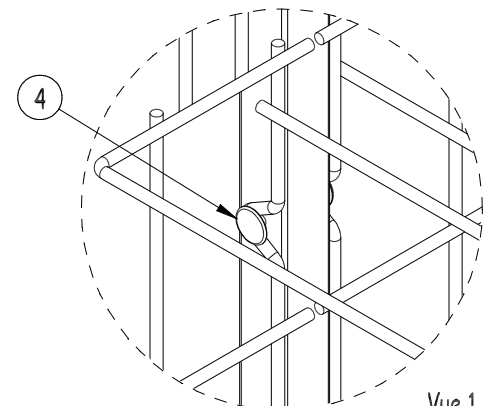
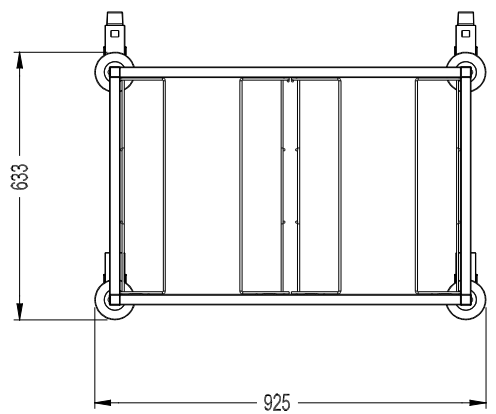
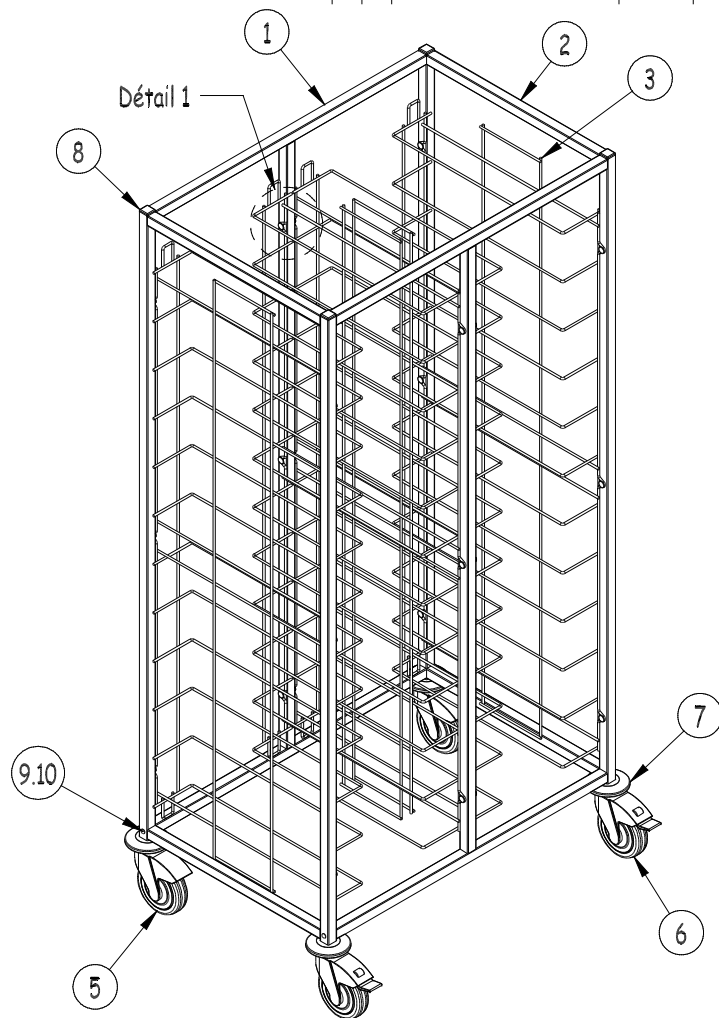
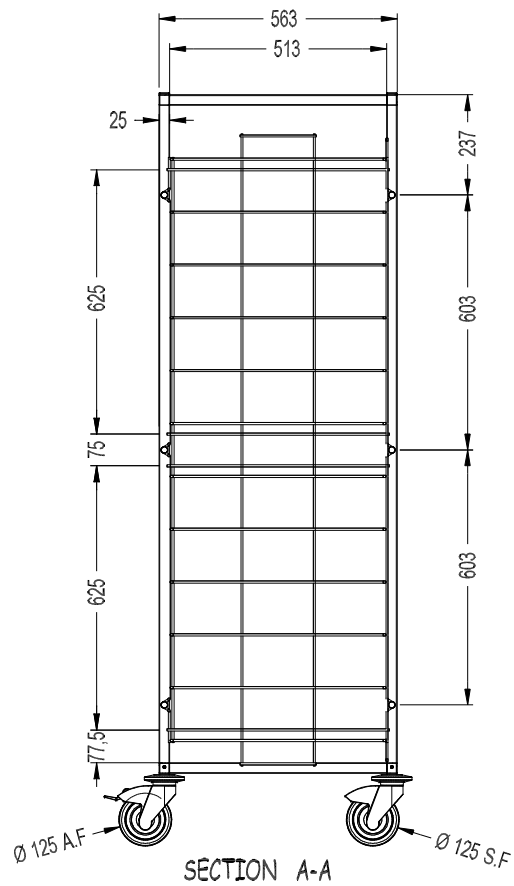
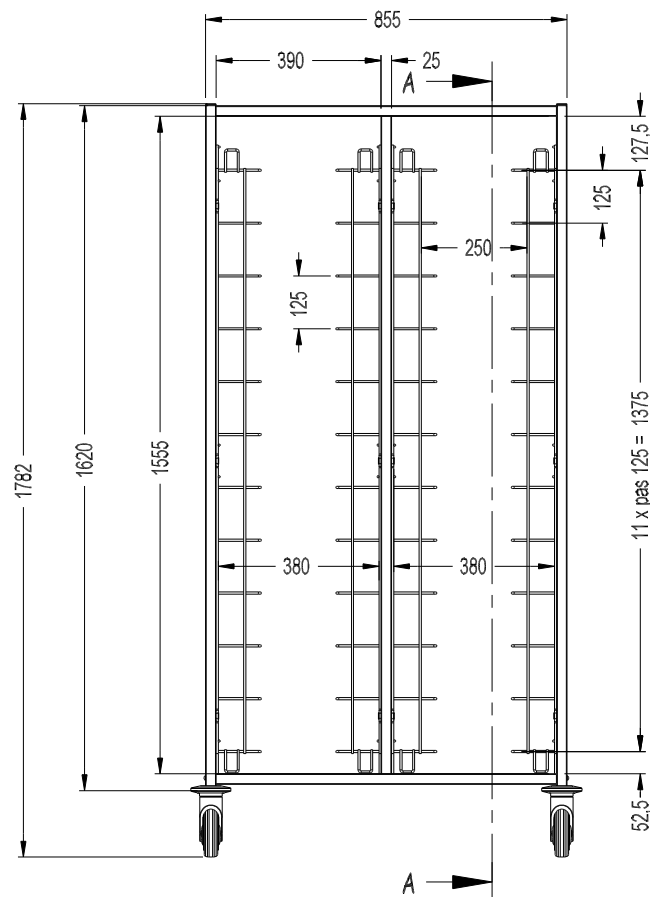

Vue 1  
0.5:1

10	RONDELLE GROWER M6 A2	4		VISR000067
9	VIS TB M6*18 TORX	4		VISV000063
8	EMBOUT CARRE NOIR	4		DIV000008
7	BUTOIR + ENTRETOISE	4		RLTB000001/ RLTD000044
6	ROULETTE PLAST. A TIGE	2	Ø125 A.F	RLTP000012
5	ROULETTE PLAST. A TIGE	2	Ø125 S.F	RLTP000011
4	RIVET TETE EXTRA-LARGE Ø4.8*16	24		DIV0001597
3	ECHELLE 12 Nx A RIVETER	4		CHDIV10479
2	TUBE 25 x 25 x 1.2	4	513	CHRSE00090
1	CADRE POUR DEBARRASSAGE 2x12	2	855 x 1820	CHRSE00193

Repère	Désignation	Nb	Dimension	Référence
<b>TSA INDUSTRIES</b> CHARIOT DE DEBARRASSAGE 12 Nx ECHELLES RIVETÉES Dessiné par: L. CARTELLI Référence: CHDEP10524 Incode: A Le: 25 Oct. 18 A3 ECH: 0.08 Matière: ACIER INOX AUSTENITIQUE Traitement: BRASSAGE Ce document est la propriété de TSA Inox et ne peut être reproduit ou communiqué sans autorisation				

< 500 mm	± 1
> 500 mm	± 2

A

A

B

B

C

C

D

D

3

4

5

6