



MAXI TOASTER



MAXI TOASTER MTS2.11 FIAMMA - 2.0.137.1001

DIMENSÕES (LxPxH)685X396X452 mm
DIMENSIONS (LxPxH)

POTÊNCIA4500 W
POWER

TENSÃO DE ALIMENTAÇÃO~220-230V/400V-2N
POWER SUPPLY

PESO LIQUIDO22 kg
NET WEIGHT

PESO BRUTO23.5 kg
GROSS WEIGHT

DIMENSÕES DA EMBALAGEM (LxPxH)810X420X490 mm
PACKAGE DIMENSIONS

MAXI TOASTER MTS2.11

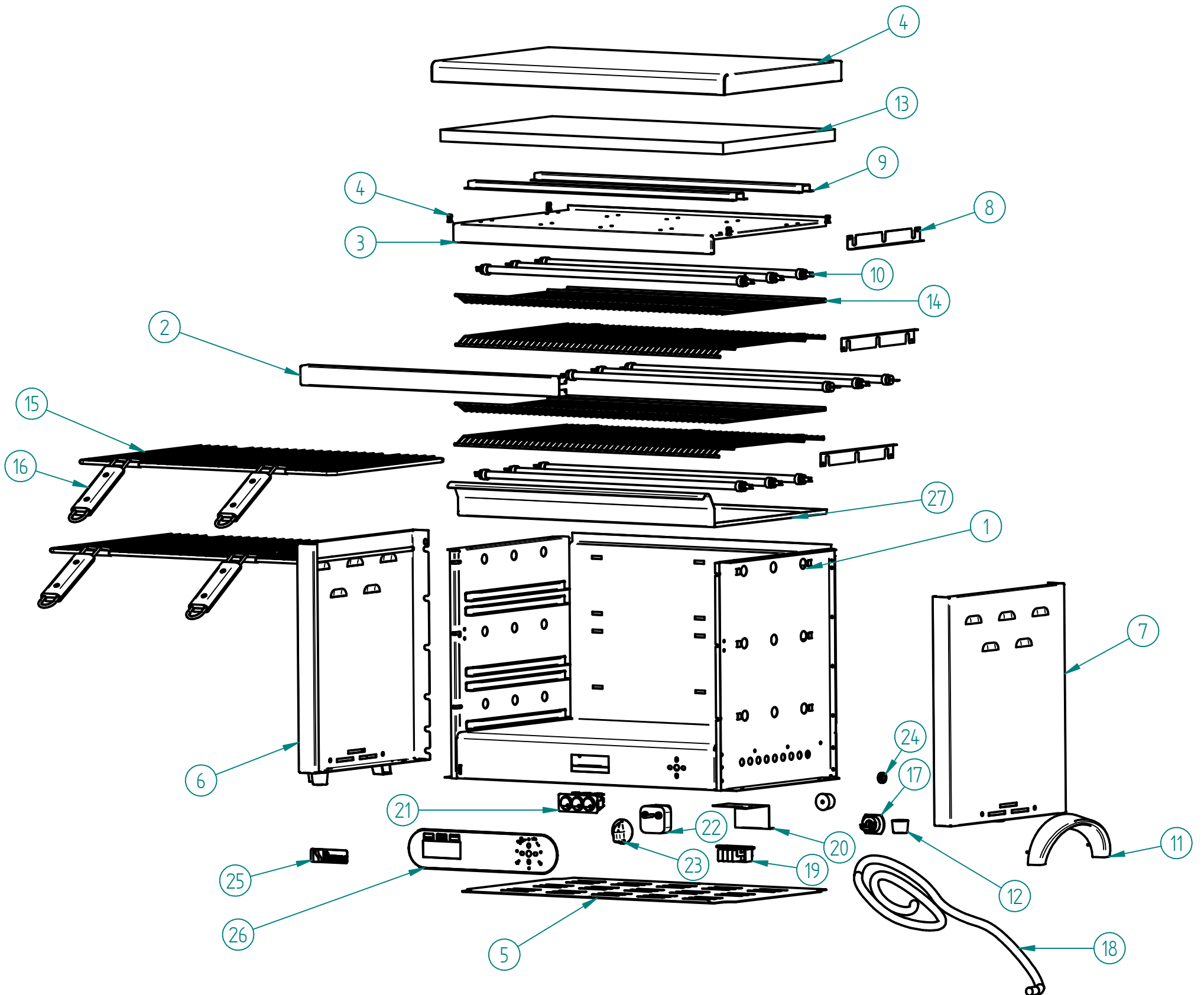

MAXI TOASTER MTS2.11 FIAMMA - 2.0.137.1001

MAXI TOASTER MTS2.11

ITEM Nº	CÓDIGO	DESIGNAÇÃO	DESIGNATION	QUANT.
1	7.0.137.0000	ESTRUTURA CONJ MTS2.11	MTS2.11 STRUCTURE SET	1
2	7.0.137.0028	REFORÇO MTS2.11	MTS2.11 GRID REINFORCEMENT	1
3	7.0.137.0026	CHAPA REFLETORA MTS2.11	MTS2.11 REFLECTIVE SHEET	1
4	7.0.137.0020	TAMPO SUPERIOR CONJ MTS2.11	UPPER COVER MTS2.11	1
5	7.0.137.0012	BLINDAGEM FUNDO MTS2.11	MTS2.11 BOTTOM SHIELD	1
6	7.0.130.0112	TAMPO LATERAL ESQUERDO SEF 450/650		1
7	7.0.130.0109	TAMPO LATERAL DIREITO SEF 450/650		1
8	7.0.137.0030	FIXADOR SILICAS MTS2.11	MTS2.11 SILICA HOLDER	3
9	7.0.137.0024	REFORÇO CHAPA REFLECT. MTS2.11	MTS2.11 REFLECT. SHEET REINFORCEMENT	2
10	4.0.137.0034	RESISTENCIA CONJUNTO 12 OHM MTS2.11	12 OHM RESISTANCE MTS2.11	9
11	4.0.075.0064	ASA PLASTICO	PLASTIC WING	2
12	4.2.000.9247	BATENTE PRETO Nº4	BLACK KNOCKER NR. 4	6
13	7.0.137.0022	ISOLAMENTO LA VIDRO MTS2.11	MTS2.11 FIBERGLASS INSULATION	1
14	4.0.137.0022	GRELHA PROTECAO SILICAS QUIN. ENC. MTS2.11	MTS2.11 SILICA PROTECTION GRID	4
15	4.0.137.0020	GRELHA MTS2.11	MTS2.11 GRILL GRID	2
16	4.0.130.0015	PEGA CONJUNTO SEF	HAND GRIP ASS.SA	4
17	4.0.125.0015	CERRA CABOS PA 277	CABLE FASTENER PA277	1
18	4.0.091.0010	CABO H07RN-F 5G2,5	H07RN-F 5G2,5 CABLE	1
19	4.0.028.0015	LIGADOR RAPIDO 5 POLOS	FAST LINKER	1
20	7.0.332.0009	SUPORTE LIGADOR RAPIDO 5 POLOS	FAST LINKER SUPPORT	1
21	4.0.000.0523	INTERRUPTOR TRIPLO TR30.2	TRIPLE SWITCH	1
22	4.0.075.0002	TEMPORIZADOR 15 MIN.	15 MIN. TIMER	1
23	4.0.075.0040	MANIPULO TEMPORIZADOR	BUTTON	1
24	4.0.074.0015	PASSA FIOS Nº1 PARA FURO Ø12,5MM	WIRE PROTECTION Ø12,5MM	2
25	4.0.201.0082	ETIQUETA FIAMMA GL (76x19mm)	FIAMMA STICKER	1
26	4.0.075.0123	PP NEUTRO TRD30.2	TRD30.2 STICKER	1
27	7.0.137.0040	TABULEIRO MTS2.11	MTS2.11 TRAY	1

MAXI TOASTER MTS2.11

1 – ESTRUTURA CONJ MTS2.11

1 – MTS2.11 STRUCTURE SET

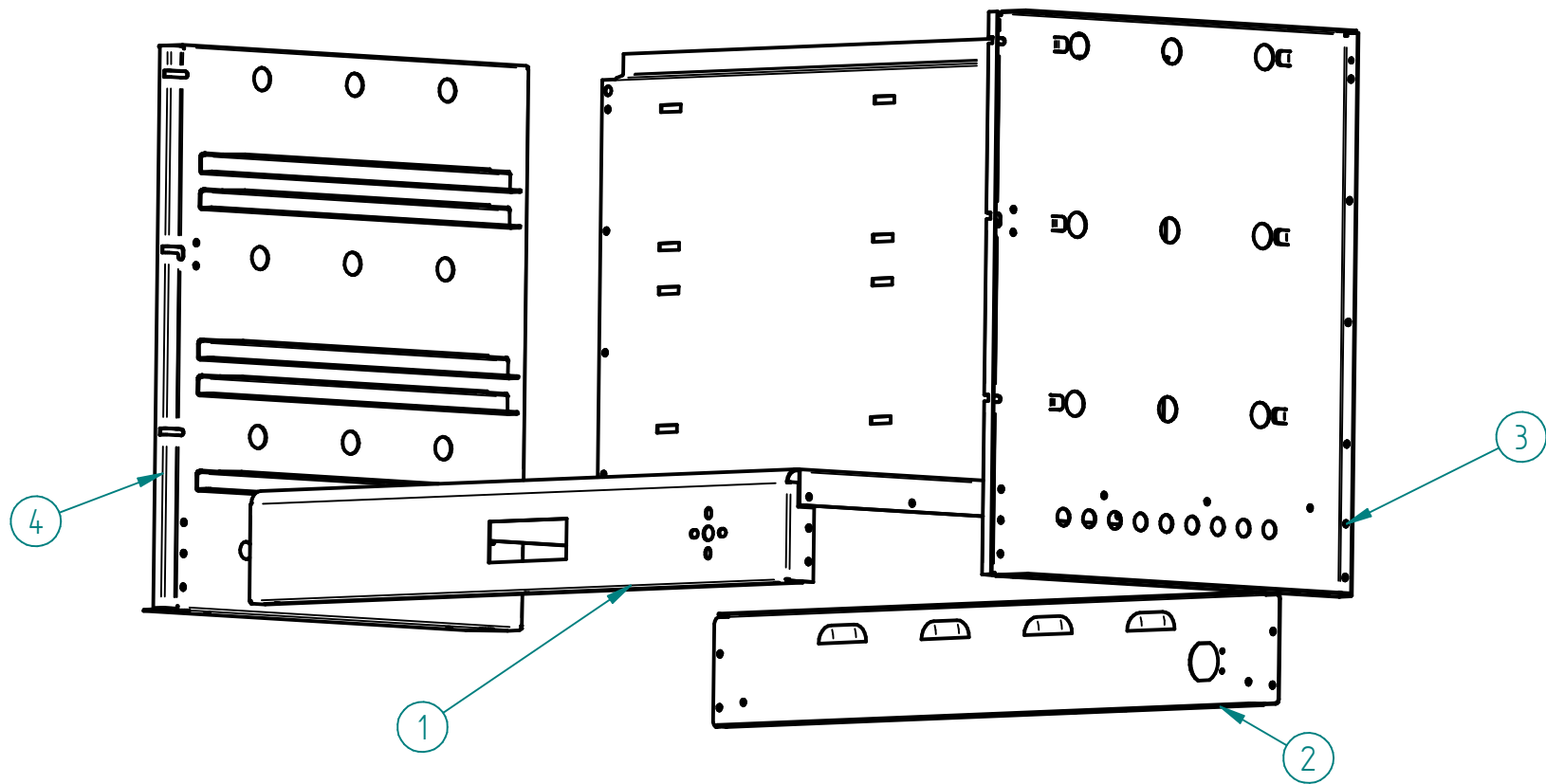

ITEM Nº	CÓDIGO	DESIGNAÇÃO	DESIGNATION	QUANT.
1	7.0.137.0001	CHASSI MTS2.11	MTS2.11 CHASSIS	1
2	7.0.137.0010	TESTEIRA POSTERIOR MTS2.11	MTS2.11 POSTERIOR FACE	1
3	7.0.137.0006	PAINEL LATERAL DIR CONJ MTS2.11	MTS2.11 LATERAL RIGHT PANEL	1
4	7.0.137.0004	PAINEL LATERAL ESQ CONJ MTS2.11	MTS2.11 LATERAL LEFT PANEL	1

10 – RESISTENCIA CONJUNTO 12 OHM MTS2.11

10 – 12 OHM RESISTANCE MTS2.11

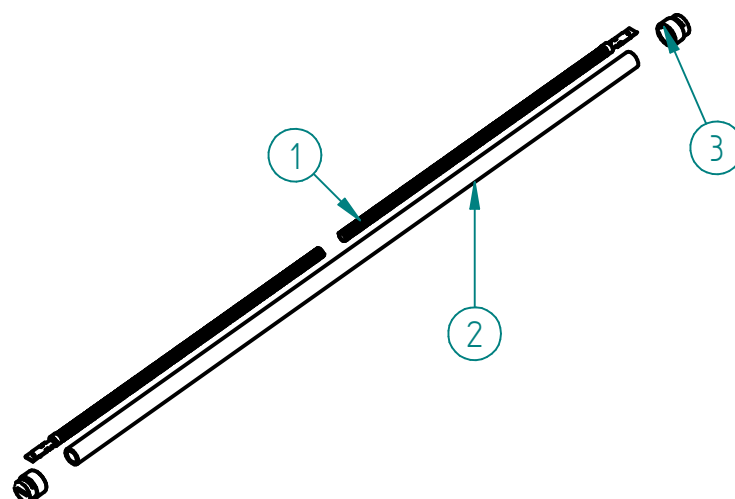

ITEM Nº	CÓDIGO	DESIGNAÇÃO	DESIGNATION	QUANT.
1	4.0.137.0032	RESISTENCIA CR NI 12 OHM C/ TERMINAIS MTS2.11	RESISTANCE CR NI 12 OHM C/ TERMINAIS MTS2.11	1
2	4.0.137.0030	TUBO SILICA Ø12X1.5X536MM	SILICA TUBE Ø12X1.5X536MM	1
3	4.0.075.0010	ISOLADOR TERMICO REF.6323/041	THERMIC ISOLATOR REF.6323/01	2

MAXI TOASTER MTS2.11

ESQUEMA ELECTRICO Electric Scheme

