



SB-H-GN-120



SB-H-GN-155



SB-H-GN-220

HOT SERIES SALAD BUFFET

1. General Information	3
1.1 Information about the instruction manual	3
1.2 Key to symbols	3
1.3 Declaration of conformity	4
2. Safety	4
2.1 General information	5
2.2 Safety instructions for using the device	5
2.3 Intended use	6
3. Transport, packaging and storage	7
3.1 Delivery check	7
3.2 Packaging	7
3.3 Storage	8
4. Technical Data	8
4.1 Technical specifications	8
4.2 Overview of parts	9
5. Installation and Operation	10
5.1 Safety instructions	10
5.2 Installation and connection	10
5.3 Operating	12
6. Cleaning and Maintenance	13
6.1 Safety advice	13
6.2 Cleaning	13
6.3 Safety, instructions for maintenance	14

İZMAK TURİZM SOĞUTMA VE END. MUTFAK SAN. TIC. LTD. STİ.

ADDRESS: Fatih Mh. 1140 Sk. No:7 Sarnic/İZMİR-TÜRKİYE

PHONE: (0090) 232 281 51 25 (PBX) **FAX:** (0090) 232 281 50 44

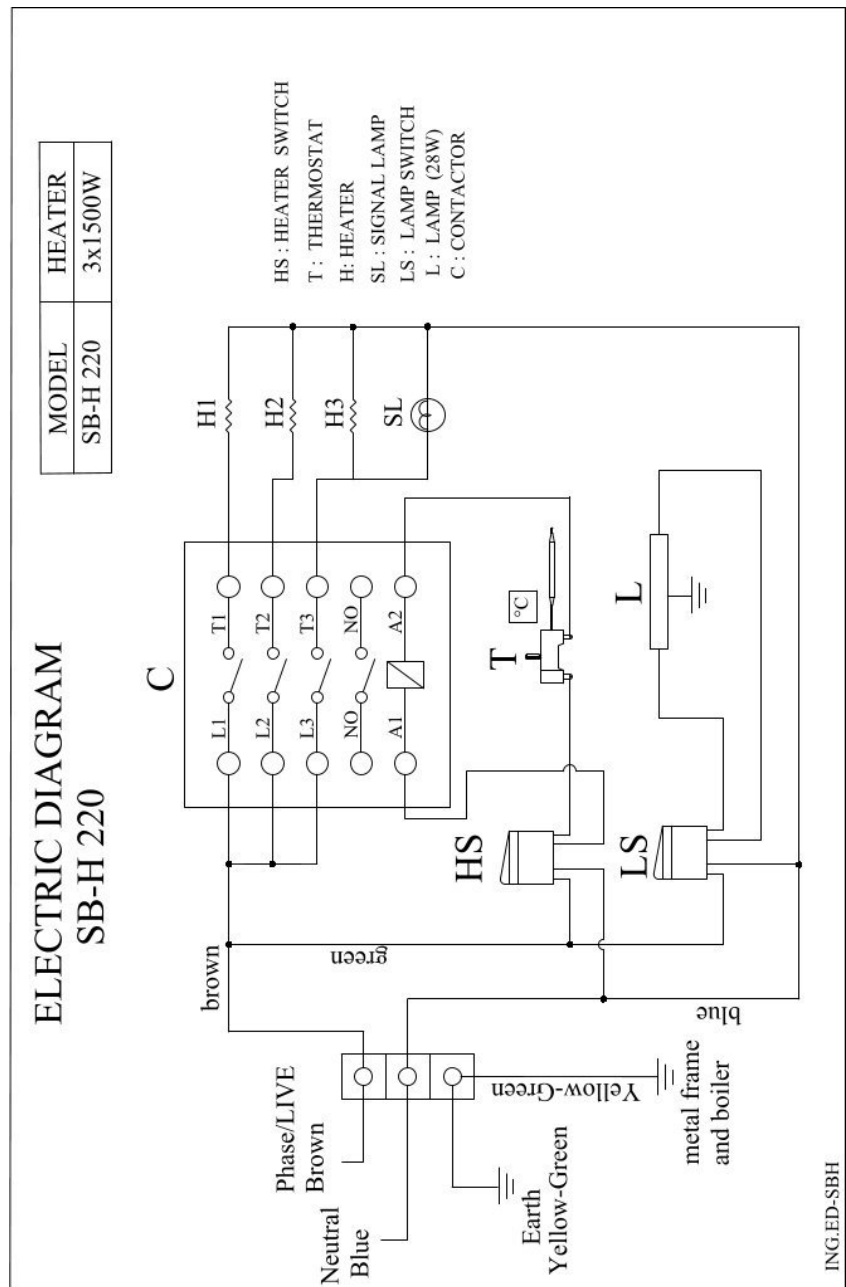

1. GENERAL INFORMATION

1.1 Information about the instruction manual

This instruction manual contains information about the installation, operation and maintenance of the device and should be consulted as an important source of information and reference guide.

Awareness of the safety instructions and instructions for use in this manual will ensure the safe and correct use of the device.

In addition to the information given here, you should comply with local health and safety controls and generally applicable safety regulations.

The instruction manual forms part of the product and should be kept near the device and easily accessible for anyone carrying out the installation, servicing, maintenance or cleaning.

1.2 Key to symbols

In this manual symbols are used to highlight important safety instructions and any advice relating to the device. The instructions should be followed very carefully to avoid any risk of accident, personal injury or material damage.



WARNING!

This symbol highlights hazards, which could lead to injury.

Please follow the instructions very carefully and proceed with particular attention in these cases.



WARNING! Electrical hazard!

This symbol draws attention to potential electrical hazards. If you do not follow the safety instructions, you may risk injury or death.



CAUTION!

This symbol highlights instructions, which should be followed to avoid any risk of damage, malfunctioning and/or breakdown of the device.



NOTE!

This symbol highlights tips and information, which have to be followed for an efficient and trouble-free operation of the device.



NOTE!

Read the instruction manual carefully before using the device. The manufacturer does not accept liability for any damage or malfunction resulting from not following the instructions for use.

The instruction manual should be kept near the device, easily accessible for anyone wishing to work with or using it. We reserve the right to make technical changes for purposes of developing and improving the useful properties.

1.3 Declaration of conformity

We certify this unit in the EC declaration of conformity.

2.SAFETY

This section provides an overview of all important safety aspects. In addition every chapter provides precise safety advice for the prevention of dangers which are highlighted by the use of the above mentioned symbols.

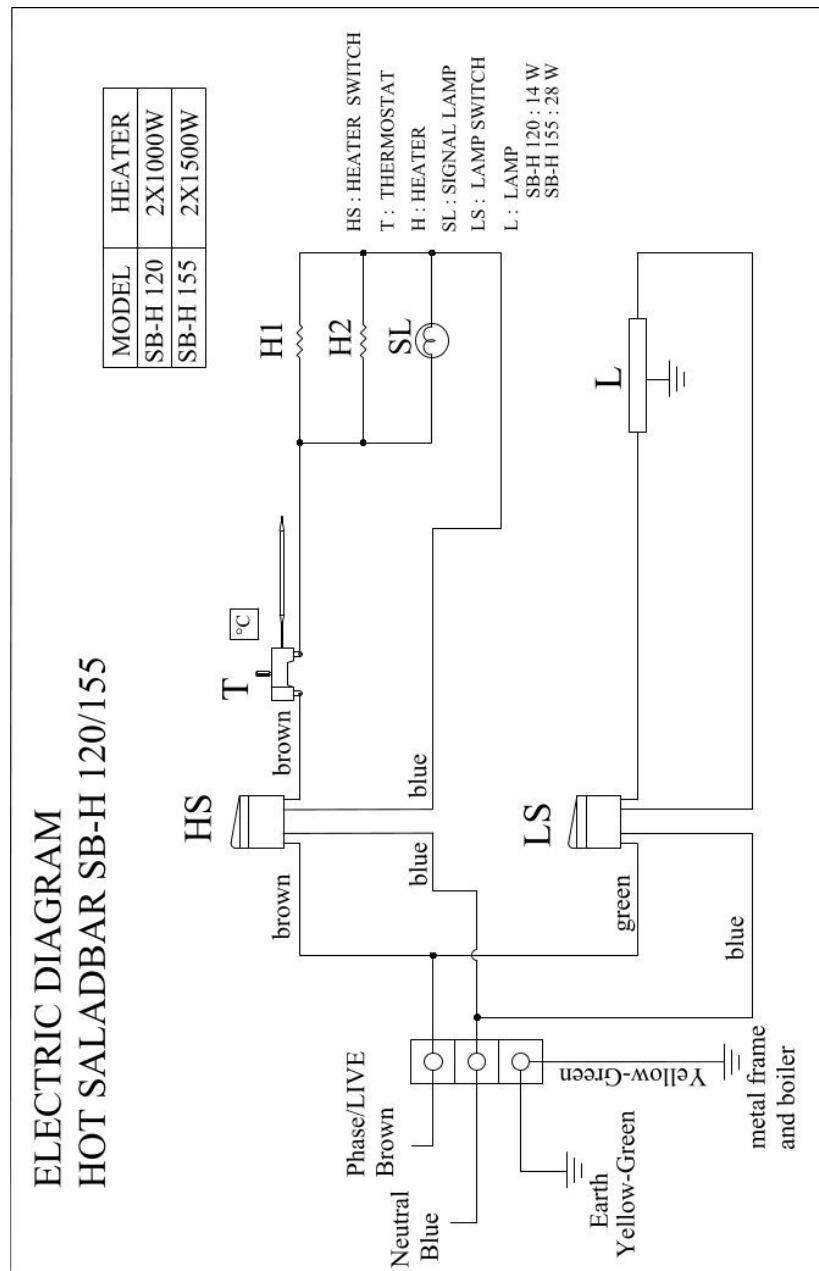

immediately be replaced by customer service or a qualified electrician to avoid dangers.

- In case of damage or malfunction, please contact your dealer or our customer service center.
- Only a qualified technician using original spare parts and accessories should carry out repairs and maintenance of the device. **Do not attempt to repair the device yourself.**

7. WASTE DISPOSAL

Discarding Old Devices

At the end of its service life the discarded device has to be disposed in accordance with the national regulations. It is advisable to contact a company which is specialized in waste disposal, or just contact the local disposal service in your community.



WARNING!

To exclude any abuse and the dangers involved make the waste device unfit for use before disposal. For that purpose disconnect device from mains supply and remove mains connection cable from the device.

Furthermore, attention should be paid to all pictograms, markers and labels on the device, which must be kept in a permanent state of legibility .

By following all the important safety advice you gain an optimal protection against all hazards as well as the assurance of a safe and trouble-free operation.

2.1 General Information

This device is designed in accordance with the presently applicable technological standards. However, the device can pose a danger if handled improperly and inappropriately.

Knowing the contents of the instruction manual as well as avoiding mistakes and thus operating this device safely and in a fault-free manner is very essential to protect yourselves from the hazards.

To prevent hazards and to ensure optimum efficiency, no modifications or alterations to the device that are not explicitly approved by the manufacturer may be undertaken.

This device may only be operated in technically proper and safe condition.

2.2 Safety instructions for using the device

The specifications regarding the industrial safety are based on the Regulations of the European Union applicable at the time of manufacturing the device. If the device is used commercially, the user is obliged to ensure that the said industrial safety measures concur with the state of the rules and regulations applicable at the time in question for the entire period of use of the device and to comply with the new specifications.

Outside the European Union, the industrial safety laws applicable at the place of installation of the device and the regional territorial provisions must be complied with.

Besides the industrial safety instructions in the instruction manual, the general safety and accident prevention regulations as well as environment protection regulations applicable for area of application of the device must be followed and complied with.



CAUTION !

- The device is not intended for use by individuals (including children) with physical or mental disabilities, insufficient experience, and/or insufficient knowledge unless such persons are under the care of a person responsible for their safety or have received instructions regarding appropriate use of the device.
- Children should be observed to ensure that they are not playing with the device.
- Preserve this manual safely. When passing on/selling the device to a third party, the manuals must be handed over along with the device.
- Every person using the device must act in accordance to the manuals and under consideration of the safety advice.
- The device is to be used indoors only.

2.3 Intended use



CAUTION !

This device has been designed and built for commercial use only and should be operated by qualified personnel only.

Safe operation is only guaranteed when using the device for its intended purpose.

Any technical interventions, as well as assembly and maintenance are to be made by a qualified customer service only.



CAUTION !

Any use going beyond the intended purpose and/or any different use of the device is forbidden and is not considered as conventional.

6. CLEANING AND MAINTENANCE

6.1 Safety advice

- Before beginning with repair or cleaning works make sure the device has been disconnected from power socket (pull the power plug!!!) and has cooled down.
- Do not use any acid agents and make sure no water ingresses the device.
- To protect yourself from electric shock, **never** immerse the device, its cables and the plug in water or other liquids.



CAUTION!

The device is not suited for direct washing via water jets. Therefore, you must not use any kind of pressure water jet for cleaning the device!

6.2 Cleaning

- Clean the device daily when finished using.
- Leave the device to cool before cleaning.
- Remove GN containers before cleaning. Clean GN containers regularly in warm water with a soft cloth and mild cleaning agent. Rinse in clean water and dry thoroughly.
- Clean the housing, worktop and storage area with a moist, soft cloth and dry thoroughly.
- Drain water from the GN container basin.
- Wash the GN container basin thoroughly with a soft cloth and mild cleaning agent, rinse with clean water and dry.
- **Never** use sharp tools or objects with sharp edges for cleaning the device.
- **Never** use aggressive chemicals (e.g. scouring powder, agents containing alcohol, solvents) as they may damage the device's surface.

6.3 Safety instructions for maintenance

- Check the mains connection cable for damage from time to time. Never operate the device when the cable is damaged. A damaged cable must

- Locate the device so that the plug is easily accessible and, in case of need, can be quickly removed.
- When the device is located in its desired place, set the rotating castors using the brakes.

Connection

The electrical circuit must be secured to a minimum of 16A. Connect the device directly to a grounded wall socket; do not use extension cords or power strips.

5.3 Operating

Before first use

- Before first use clean the device thoroughly (**6.2 "Cleaning"**).
- Ensure that the drain tap is closed.
- Ensure that the device is turned off.
- Connect the device to a single grounded outlet.

Tips for use

- For storing plates and other heavy items, use the lower portion of the device and included shelving.
- Place warm food products into the device so that they are more quickly ready to be served.



CAUTION!

When you will put down the cover head, please make sure the granite counter of the salad bar won't have any items on it.

Any claims against the manufacturer purpose or his authorized representative as a consequence of experiencing damages resulting from unconventional use are impossible.

The operator is liable for all damages resulting from inappropriate use.

3. TRANSPORT, PACKAGING AND STORAGE

3.1 Delivery check

Please check the delivery upon completeness and transport damage immediately after receipt. In case of visible damage do not accept or accept the delivery with reservation only.

Note the extent of damage on the carrier's bill of delivery. Trigger off the complaint.

Hidden damages should be reclaimed immediately after notice, as claims for damages can only be asserted within the effective period for complaints.

3.2 Packaging

Please do not throw away the covering carton of your device as it might be useful for storage purposes, when moving or, in case of damages, when the device must be sent back to a repair center. The outer and inner packing material should be removed completely from the device before installation.



NOTE!

If you would like to dispose the packing, consider the regulations applicable in your country. Supply re-usable packing materials to the recycling.

Please inspect the device upon completeness. In case any part is missing please contact our customer service center immediately.

3.3 Storage

Keep the package closed until installation and under consideration of the outside indicated positioning- and storage markings.

Packages should be stored under consideration of the following:

- Do not store outdoors.
- Keep it dry and dust-free.
- Do not expose it to aggressive media.
- Do not expose it to direct sunlight.
- Avoid mechanical shocks and vibration.
- In case of longer storage (>3 months) make sure you check the state of the packaging and the parts regularly.
- If required refresh or renew.

4. TECHNICAL DATA

4.1 Technical specifications

MODEL	SB-H-GN-120	SB-H-GN-155	SB-H-GN-220
WIDTH (cm)	120 cm	155 cm	220 cm
CAPACITY	3 x 1/1 GN	4 x 1/1 GN	6 x 1/1 GN
VOLTAGE	220 V		
FREQUENCY	50 Hz		
HEATING FOILS	2 x 1000 W	2 x 1500 W	3 x 1500 W
WORKING TEMPERATURE	+30°C/+90°C		

Tray Slider Shelf

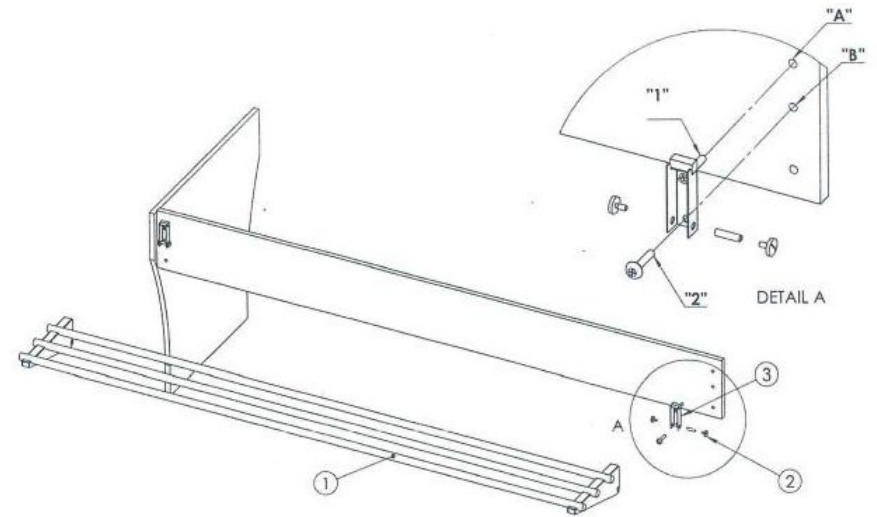

fig.3

- If necessary, the sliding tray shelf can be folded (fig.4)



fig.4

Setup

- Place the device on a flat, secure surface that can support the device's weight.
- **Never** place the device on a flammable surface.
- **Do not** place the device near an open flame, electric or other heater, nor any other source of high temperatures.



WARNING! Hazard via electrical current!

The device can cause injuries due to improper installation!
 Before installation the local power grid specification should be compared with that of the device (see type label).
 Connect the device only in case of compliance!
 Take note of the security advice!

5.2 Installation and connection



CAUTION!

Installation and maintenance of the device may be carried out only by qualified personnel.

ASSEMBLY OF SLIDING TRAY SHELF (fig.3)

- For mounting the brackets (3) of the sliding tray shelf, use holes "A" and "B" (the upper openings of the wooden panel). First, remove the plugs from the openings.
- Mount the bracket (3) on the wooden panel, by screwing bolt "1" in opening "A" and bolt "2" in opening "B".
- Mount the sliding tray shelf (1) on the brackets and adjust its position using the attached spacer bolts (2).

4.2 Overview of parts

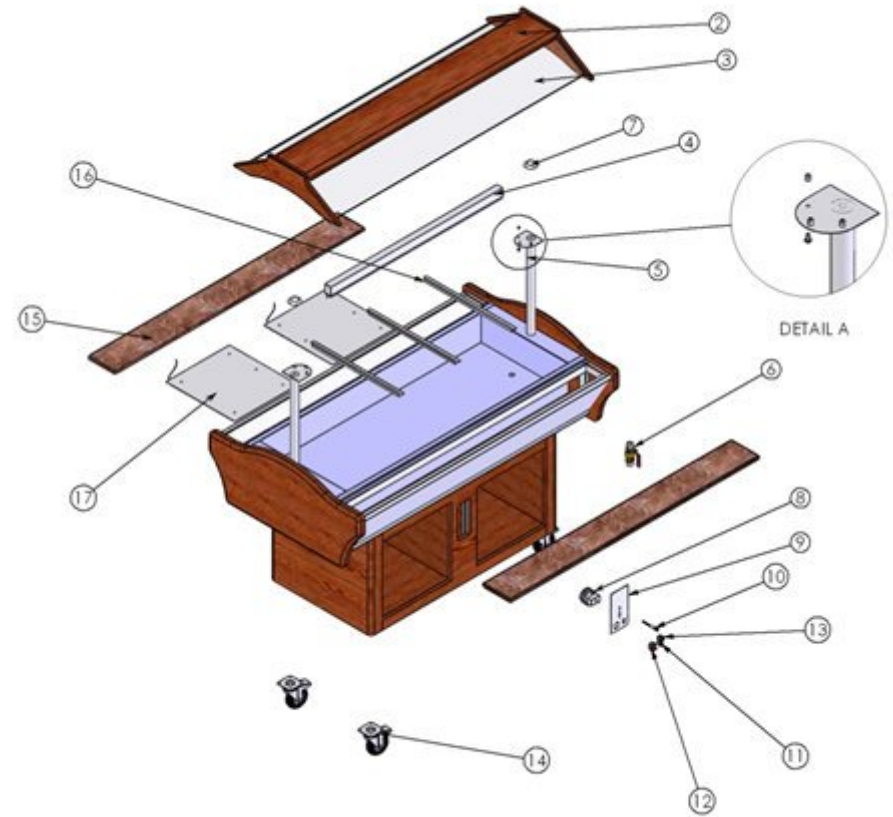

ATTENTION:

For assembling the light please fix the rod (#5) to the wooden cover (#2) by using the screws in the bag.

No	Item description	Item code	pcs.
002	Saladbar lamp wooden cover	SHAHAY12MHA1	1
003	saladbar lamp glass cover	SHCG1200A100	2
004	Lamp	SHELAR28A100	1
005	Rod	YMBRSBA10000	2
006	Ball valve	SHGMVN0304A1	1
007	Pipe ring	SHGMRZ000000	2
008	Thermostat	SHELST01A100	1
009	Control panel SB-H	SHELKPSB02A1	1
010	Signal lamp	SHELSTLYSA100	1
011	Lighting switch	SHELWONA100	1
012	On-off switch	SHELWONA100	1
013	Thermostat switch	SHELWTHA100	1
014	Wheel (free / with brake)	SHSMTKFR0100 / FZ0100	2/2
015	Granite working counter	SHGR121A0000	2
016	GN pan basis	YMGNPBNS0100	2,3,5
017	Resistance	SHELRZ150000	2

*1

Note*1: Furniture Color **SB-H-120** Mahogany: SHAHAY11MHA1
 Cherry: SHAHAY11AKA1
 Walnut: SHAHAY11CVA1
SB-H-155 Mahogany: SHAHAY12MHA1
 Cherry: SHAHAY12AKA1
 Walnut: SHAHAY12CVA1
SB-H-220 Mahogany: SHAHAY14MHA1
 Cherry: SHAHAY14AKA1
 Walnut: SHAHAY14CVA1

5. INSTALLATION AND OPERATION

5.1 Safety instruction

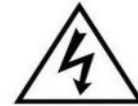

WARNING! Electrical hazard!

The device must only be connected to a properly installed single socket with protective contact.

Never yank cord to disconnect from outlet. Cable must not touch any hot parts.

- See that the cable does not touch any heat sources or sharp edges. Do not let the cable dangle over the counter edge.



WARNING! Hot surface!

During operation some elements of the device become very hot. To avoid burns, do not touch hot elements!

- Do not use the device in case it does not function properly, has been damaged or dropped.
- Do not use any accessory or spare parts that have not been recommended by the manufacturer. These can be dangerous for the user or lead to damages of the device or personal injury, and further, the warranty expires.
- Do not lay the cable over carpets or heat insulations. Do not cover the cable. Keep away the cable from operating range and do not dunk it into water.
- Do not move or tilt the device when in operation.