



EPiC Series in Built Environment

Volume XXX, 2026, Pages 1–10

Proceedings of Associated Schools of Construction 62nd Annual International Conference



Assisting Mechanical Equipment Transportation and Installation with Visual Guidance: A Comparison between Site Plans and Augmented Reality

Lijun Liu¹, Ngoc Thi Nhu Nguyen², and Yilei Huang, Ph.D.²

¹The Bell Company, North Charleston, South Carolina

²East Carolina University, Greenville, North Carolina

Mechanical equipment needs periodical maintenance and replacement to sustain essential building functions. Due to the complex room layout and numerous existing equipment within the mechanical room, it presents unique challenges in efficiently and safely performing such maintenance and replacement tasks. This paper investigates the approach of using Augmented Reality (AR) technology to assist with mechanical equipment installation within existing facilities. With its capability to overlay digital information on top of the physical environment, AR technology can provide additional visual guidance with 3D models and spatial mapping, allowing navigation guides, real-time distance measurements, and safety alerts. A pilot case study is presented to compare the workflow between the traditional site plan approach and the AR assistance approach for mechanical equipment installation planning. The results suggested significant improvements in efficiency, accuracy, and safety. The findings of this study demonstrated the potential of AR technology in assisting mechanical equipment installation for existing facilities, improving efficiency, safety, and effectiveness.

Keywords: Mechanical, Existing Facilities, Maintenance, Installation, Augmented Reality

Introduction

Mechanical equipment installation and maintenance is indispensable within existing facilities, especially for segmenting and transporting heavy components such as chillers, boilers, and pressure vessels. In conventional approaches, facility workers must measure the clear space in the equipment transportation route and evaluate potential risks, which is laborious, repetitive, and error prone. With the development of Building Information modeling (BIM), facility engineers can now measure the precise distance in the BIM models for more accurate dimensions and efficient transportation route planning (Cheng et al., 2020).

Although BIM models can represent the accurate sizes and mechanical equipment to be transported and installed as well as the available building spaces, in some cases, the facilities are confined to the sectional dimensions, and the BIM models cannot simulate the entire equipment transportation route. Utilizing Augmented Reality (AR) technology can potentially streamline mechanical equipment

transportation and installation by reducing repetitive tasks and minimizing the potential damage to the equipment, thus enhancing job efficiency and safety.

AR technology offers a promising alternative, particularly in alleviating facility engineers' workload (Fazel & Izadi, 2020). An augmented reality headset, such as the Microsoft HoloLens 2, can be programmed to plan the entire clear space route for mechanical equipment transportation. The AR headset can be used to visualize full scale BIM models of mechanical equipment to simulate the actual transportation process and identify the potential risks, which drastically reduces facility engineers' intervention and increases the accuracy of measurements.

This paper investigates the approach of using AR technology to assist with mechanical equipment installation within existing facilities using a pilot case study to compare the workflow between the traditional site plan approach and the AR assistance approach. The study explores how AR technology can assist mechanical equipment transportation by providing real-time visualization, navigation guidance, safety alerts, as well as improved communication and coordination. The findings of this study demonstrated the potential of AR technology in assisting mechanical equipment installation for existing facilities, improving efficiency, safety, and effectiveness.

Literature Review

The transportation and installation of mechanical equipment within existing facilities presents a unique set of challenges, encompassing logistical, operational, and safety considerations, including:

- **Logistic challenges.** The sheer size of large mechanical equipment poses significant logistical challenges. Navigating through confined spaces, negotiating turns, and coordinating movements become intricate tasks (Wang & Piao, 2019). There is a need for precise planning, route optimization, and advanced technologies such as real-time tracking systems to streamline logistical operations (Bortolini et al., 2020).
- **Structural limitations.** Existing facilities often have fixed structures and layouts that are not initially designed to accommodate the transportation of mechanical equipment (Deng et al., 2020). Assessing structural limitations, including door sizes, ceiling heights, and floor load capacities, is vital to determine the feasibility of mechanical equipment installation within these facilities.
- **Safety concerns.** Safety is a paramount concern in mechanical equipment transportation and installation. The risk of accidents, collisions, and damage to equipment and the facility infrastructure can be reduced significantly with comprehensive safety protocols and operator training programs (Fang et al., 2020).

While the complex character of transporting mechanical equipment within existing facilities recognizes the diverse challenges encompassing logistics and safety concerns, with the development of BIM and AR technologies, implementing innovative solutions will play a pivotal role in overcoming these challenges and solving the complexities of transporting mechanical equipment within confined spaces of existing facilities (Chalhoub & Ayer, 2019). BIM represents the creation of a comprehensive 3D virtual design that incorporates the physical and informational aspects of a construction project (Lee et al., 2006). Studies have highlighted the potential of BIM to enhance design visualization and interaction, especially for architects (Yan et al., 2011). Additionally, the increasing capabilities of mobile and tablet-based devices have facilitated the on-site utilization of BIM for model visualization and progress documentation (Davies & Harty, 2013).

On a different technological front, AR has introduced the possibility of photorealistic on-site visualization of BIM models (Wang & Love, 2012). As the construction industry continues to expand

its use of BIM in facility management, a growing repository of 3D content in mechanical equipment can be further harnessed by manufacturers with emerging visualization technologies. Milgram and Kishino (1994) mentioned that AR has overlapped virtual contents onto a predominantly accurate view. Efforts have been directed towards seamlessly migrating BIM contents to AR environments, unlocking diverse applications in the industry (Williams et al., 2015). AR proves invaluable for existing facilities and planning spatial improvements (Thomas & Sandor, 2009; Thomas et al., 2000). Additionally, AR has extended its applications in site monitoring and documentation, contributing to risk reduction and offering contextual safety instructions (Zollmann et al., 2014; Guo et al., 2017). These endeavors showcase the potential of AR to provide substantial value in design and construction applications, mainly when practitioner- and user-possessed domain-specific expertise is employed. AR enables facility engineers to grasp site conditions through simulated environments (Mutis & Issa, 2014; Shanbari et al., 2016).

Methodology

Experiment Design

This research study aims to investigate the effectiveness of AR headsets on assisting mechanical equipment transportation and installation in existing facility sites and compare the workflow and efficiency between the traditional site plan approach and the AR assistance approach. The traditional approach requires facility workers to use site plans and measuring tools to manually verify the dimensions of mechanical equipment and clear spaces needed for the entire transportation and installation route. The AR assistance approach provides interactive information through an AR headset that allows facility workers to visually evaluate the transportation route and installation space of the mechanical equipment in an existing facility. The specific requirements for the interactive information within the AR headset include:

- Measurements. Measurement tools measure distances between two points in the model or between the model and the physical space.
- Alignment. Spatial registration or alignment allows users to align the BIM model with the physical environment. This provides an accurate overlay of the model elements on the built components. Once aligned, the user can verify the accuracy of the model components against reality.
- Layers. Different layers hide or unhide parts of the models or a complete model if multiple models are launched together. This allows the user to filter parts of the model and highlight specific components.

The AR assistance approach follows the workflow below to complete the transportation and installation of mechanical equipment in an existing facility:

1. Identify critical challenges in mechanical equipment transportation within the existing facility, such as spatial constraints and safety concerns.
2. Assess the suitability of AR headset for addressing transportation challenges, considering features like spatial mapping and AR capabilities.
3. Create BIM models of mechanical equipment to enable virtual visualization and interaction.
4. Utilize spatial mapping capabilities of the AR headset to understand facility layouts and optimize equipment transportation routes.
5. Develop an algorithm for dynamic route planning, considering real-time factors such as facility congestion and equipment status.

Hardware and Software

Microsoft HoloLens 2 was selected as the AR headset for this research study due to its availability, spatial mapping capabilities, and easy setup process and non-dependence on external hardware (e.g., workstation computers with high-end graphics) (Schiavi et al., 2022). Its see-through holographic lenses provide the facility engineer a diagonal field of view of 52 degrees with a display resolution of 1440x936 pixels per eye to interact between the BIM models and physical facility site (Microsoft, 2023).

Trimble Connect MR was selected as the software platform for this research study due to its compatibility with Microsoft HoloLens 2, availability for academic uses, and capabilities of performing measurements, alignment, and layers. Specifically, the QR code alignment method was used to perform BIM model alignment. Trimble Connect MR allows the user to view the BIM model graphics and information created by Autodesk Revit and is designed to assist informed decision-making with cloud-based model access (Trimble, 2024).

In addition to Trimble Connect MR, Unity was also considered as the software platform but not adopted. Unity is a game engine platform that allows manual deployment of AR applications for performance assessment. It offers more flexibility in software design and interaction, enabling developers to create immersive 3D experiences. However, programming codes are required to add or to drive interaction functions and Unity only allows to deploy AR applications to HoloLens one project at a time (Bock, 2015). Based on the available features and tools provided by Trimble Connect MR and Unity, Trimble Connect MR was considered better suited for general purpose uses in this study while Unity focuses more on customized uses for more complex software development needs.

Case Study

To assess the effectiveness of using AR technology for mechanical equipment installation planning in existing facilities, a pilot case study experiment was performed using both the traditional site plan approach and the AR assistance approach to compare their workflow and efficiency. In addition, the visual guidance provided by the AR headset with BIM models and spatial mapping, including navigation guides, real-time distance measurements, and safety alerts, were also verified.

Experiment Background

The experiment was carried out in one of the chilled water plants using the compound condensation process (CCP #3) on the main campus of East Carolina University (ECU). The CCP #3 plant is a two-story building vital to ECU's campus facilities and is pivotal in temperature control and climate regulation. This specialized room houses equipment essential for cooling, primarily focusing on chillers. The pipeline system within CCP #3 comprises a network of interconnected pipes facilitating the cooling fluid flow. The pipeline is meticulously designed to ensure efficient and reliable cooling throughout the facility. The detailed layout of CCP #3 is presented in Figure 1, where the equipment installation position is highlighted in green. The new mechanical equipment to be transported and installed is a large basin sweep pump. Due to the space restriction, there is only one possible route for the equipment to be transported, as indicated by the red arrow in Figure 1.

Site Plan Approach

To ensure the mechanical equipment can be transported smoothly, the clearance during the route in the utility room of the existing facility must be measured. A team of three experienced full-time facility workers was assigned to this task using the following method:

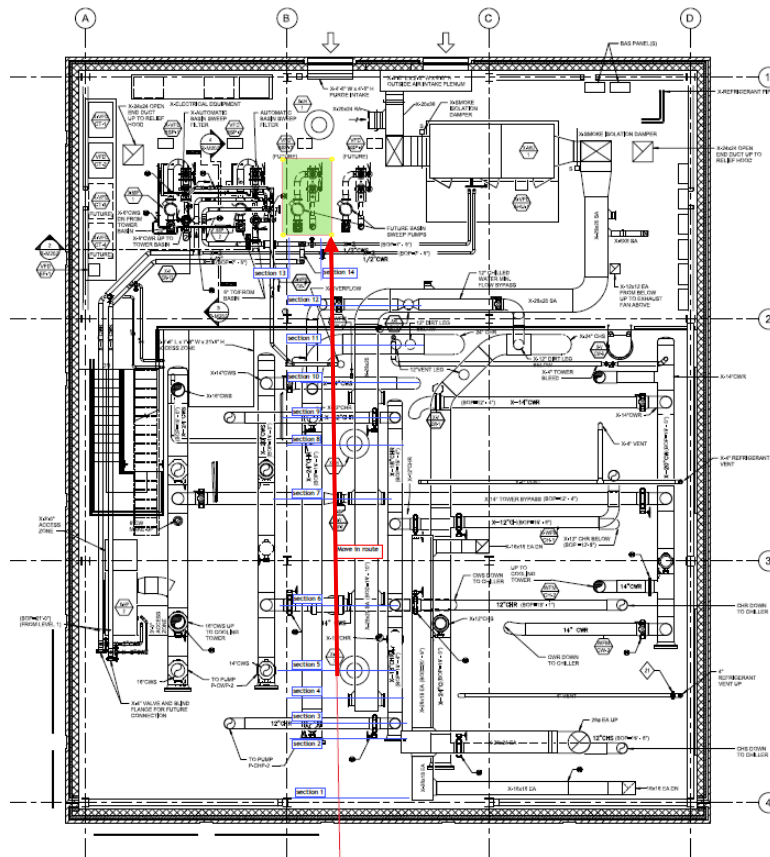

Figure 1. Layout of the CCP #3 with the new equipment transportation route

1. Define the equipment dimensions. Obtain detailed specifications for the mechanical equipment that needs to be installed in the utility room, which includes height, width, length, and any protruding components.
2. Review utility room plans. Review the drawings of the CCP #3 room. Identify existing mechanical equipment, supporting structures, and other fixed installations within the utility room. In total, 14 sections needed to be measured during the transportation route, and their locations are marked in Figure 1 in blue.
3. Measure clearances. Use a measuring tape to measure the clearance along the transportation route. Special attention should be given to narrow passages, doorways, and potential bottlenecks. Ensure that there is sufficient vertical clearance to accommodate the height of the equipment.
4. Equipment positioning. Measure the accurate position of the basin sweep pump to ensure sufficient space for the equipment to be installed.
5. Document and confirm measurements. Document all measurements and observations. Confirm the measurements with the relevant stakeholders, including facility managers, equipment operators, and safety personnel.

AR Assistance Approach

One facility engineer performed the AR assistance approach using HoloLens 2 headset after a comprehensive training session to measure the clearance of the equipment transportation route with real-time visualization following the steps below:

1. Create model. Obtain the 3D model of the new equipment from the manufacturer and convert it to an Autodesk Revit model, as demonstrated in Figure 2.
2. Import model. Import the Revit model of the equipment to Trimble Connect MR in HoloLens 2 ensuring accurate scale and representation.
3. Visualize model. Overlay the BIM model of the new equipment into the real-world environment with HoloLens 2.
4. Obstacle detection. Implement dynamic obstacle detection algorithms within HoloLens 2 to identify and highlight potential obstacles that may not be apparent in the static digital model.
5. Measure clearances. Use Trimble Connect MR to measure clearances in the utility room, such as checking distances between the equipment and closest existing structures, doorways, or other potential obstacles, as demonstrated in Figure 3.
6. Position alignment markers. Place QR codes in both the BIM model and the matching installation location as reference points for aligning the model within the physical space.
7. Record measurements and observations. Measurements and observations can be recorded directly within the HoloLens 2 interface and will be used for future reference.
8. Generate reports. Generate reports based on the visual measurements from Trimble Connect MR and provide a comprehensive overview of clearances and challenges.

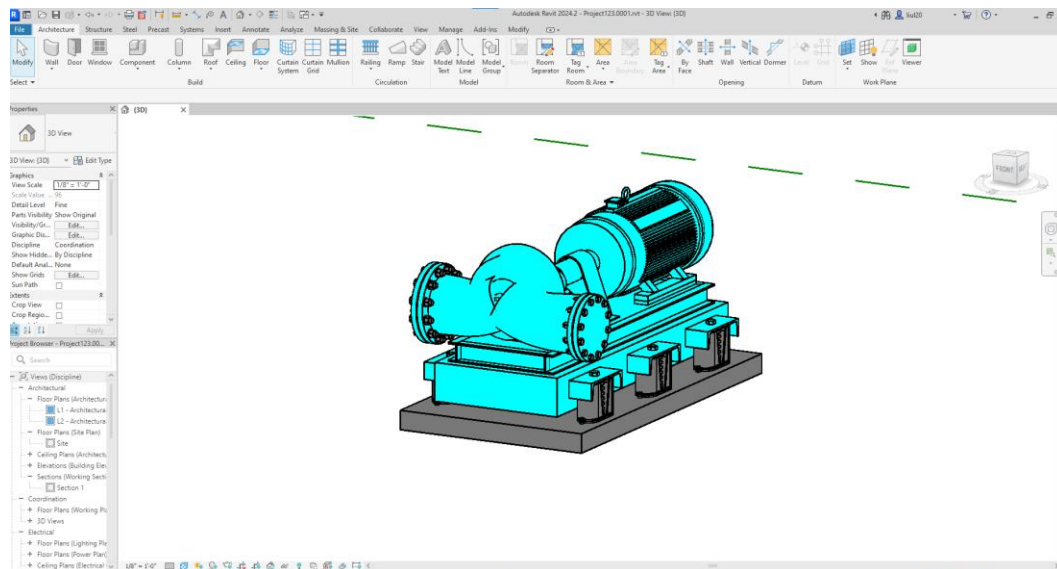

Figure 2. Revit model of the new mechanical equipment

Result Comparison

The experiment results between traditional site plan approach and AR assistance approach were compared in terms of their efficiency, accuracy, safety, collaboration, as well as training and skill requirements.

- Efficiency. The site plan approach relies heavily on human labor and physical effort, and their skill level and experience significantly impact efficiency. In this pilot case, 14 sections during the transportation route must be measured and each section took 10 minutes for the 3-

member team. Therefore, the total time needed was $14 \times 10 \times 3 = 420$ person-minutes. In the AR assistance approach, the AR headset can enhance efficiency by providing real-time information and visual guidance. Engineers can access the BIM model and other relevant data hands-free, constantly reducing the need to refer to paper plans. In this pilot case, one facility engineer took 60 minutes to complete the task with HoloLens 2, resulting in a total time of 60 person-minutes.

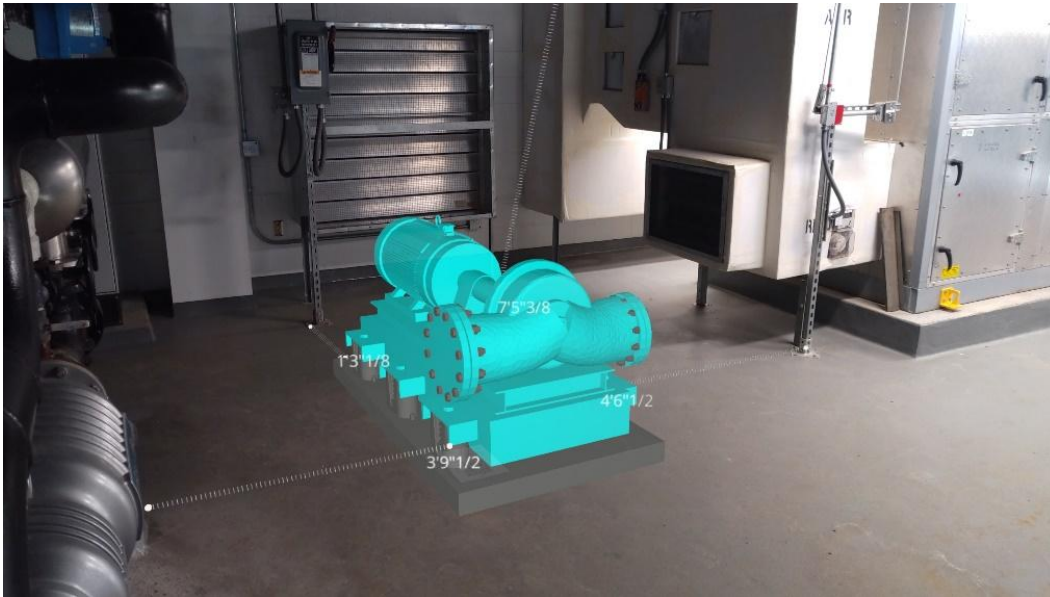

Figure 3. Using Trimble Connect MR to measure clearances in the real world

- **Accuracy.** The site plan approach is prone to human errors in measurement. In this pilot case, 25 measurement results were out of the accuracy requirement of ± 250 mm after double checking. The AR assistance approach offers precise measurements and accurate placement of elements through AR overlays and helps reduce errors by providing visual aids and step-by-step guidance. Nevertheless, it relies on the user's ability to correctly use the AR measurement tool. In this pilot case, seven measurement results were out of the accuracy requirement of ± 250 mm after double checking.
- **Safety.** The site plan approach brings inherent physical risks associated with using manual tools. The facility workers received six hazard warnings in this pilot case, such as falls or other injuries. The AR assistance approach can contribute to improved safety by providing real-time hazard warnings and visualizing potential risks on the construction site. Operators can access safety guidelines and information through the AR headset, promoting a safer working environment. The facility engineer received no hazard warnings in this pilot case.
- **Collaboration.** In the site plan approach, communication relies on verbal instructions and physical presence. Coordination among team members may be challenging, especially in large construction sites. In this pilot case, the facility workers met ten times and misunderstood instructions. The AR assistance approach facilitates better collaboration through features like remote assistance and shared holographic experiences, which allow stakeholders to collaborate virtually and make decisions based on a shared understanding of the project. In this pilot case, since one facility engineer was operating the AR headset, collaboration was unnecessary.

- **Training.** The site plan approach relies on traditional construction skills, which can take time to master. In this pilot case, the facility workers were from ECU Facilities Services and training is unnecessary. The AR assistance approach requires training in using AR technology and gesture controls, but it could reduce the learning curve for specific construction tasks. In this pilot case, the facility engineer took 30 minutes to familiarize himself with the controls of HoloLens 2 and navigate through the tutorials, and no further training was needed.

In conclusion, adopting AR technology in mechanical equipment transportation and installation can offer advantages in terms of efficiency, accuracy, safety, collaboration, and training. However, the implementation may also require an initial investment in technology and training for the workforce. The choice between manual tools and AR technology would depend on factors such as project complexity, budget considerations, and the willingness of the construction team to embrace technological advancements.

Discussion

In the pilot case study experiment, the facility engineer wearing the AR headset reported discomfort, eye strain, and sore arms due to prolonged air tapping within the field of view of HoloLens 2. Inconsistent speech recognition was also noted, affected by loud noises in the mechanical room. The capabilities of Trimble Connect MR were contingent on a robust Wi-Fi signal, posing challenges in certain building areas with weak or unavailable internet, such as the basement level housing the mechanical room. In addition, the limited field of view of HoloLens 2 also hindered a comprehensive view of equipment or its context in confined spaces, requiring the user to either step back or scan around to see the entire BIM models. Safety concerns also emerged in congested areas like mechanical rooms.

From an effectiveness perspective, this pilot case study adequately verified that the measurement tools in AR headsets offered various options with reasonable accuracy. Nevertheless, noted concerns included the visibility of distant objects, objects in low-lit areas, or object colors too close to model colors. Addressing visibility concerns involved coloring model elements differently than their true color and adjusting the headset opacity settings. While the measurement tools provided diverse options, frustrations could still arise when selecting the starting and ending points of the distances to be measured between the model and the physical space. In addition, this single-user design pilot case study and the specific facility context may affect the generalizability of its effectiveness.

Conclusions

As construction technology advances, implementing AR technology for mechanical equipment transportation and installation within existing facilities holds immense promise and potential to enhance job efficiency, safety, and overall productivity. The integration of AR technology offers facility workers real-time, context-aware information, assisting the accurate planning of transportation routes of mechanical equipment. AR applications minimize errors and optimize workflows by providing users an augmented view of mechanical equipment models within their surroundings. Furthermore, AR technology fosters improved training methodologies to enhance worker skills through remote assistance and mitigate safety risks associated with real-world training scenarios.

This paper investigates the approach of using AR technology to assist with mechanical equipment installation within existing facilities. A pilot case study was presented to demonstrate how an AR headset was employed to provide real-time visualization, navigation guidance, safety alerts, as well as

improved communication and coordination, and the results were compared with the traditional site plan approach for mechanical equipment transportation and installation. The findings of this study highlight the transformative potential of AR technology in improving efficiency, safety, and effectiveness in mechanical equipment transportation for existing facilities. Continued research, development, and integration of AR solutions are required to revolutionize how existing facilities operate and mechanical equipment are managed, and the key lies in fostering a seamless integration between operational frameworks, user experience, data accuracy, and system compatibility.

References

- Bortolini, R., Formoso, C.T., & Viana, D.D. (2019). Site logistics planning and control for engineer-to-order prefabricated building systems using BIM 4D modeling. *Autom. Constr.* 98, 248-264. <https://doi.org/10.1016/j.autcon.2018.11.031>.
- Bock, T. (2015). The future of construction automation: Technological disruption and the upcoming ubiquity of robotics, *Automation in Construction*, 59, pp. 113-121. <https://doi.org/10.1016/j.autcon.2015.07.022>.
- Cheng, J.C., Chen, K., & Chen, W. (2020). State-of-the-art review on mixed reality applications in the AECO industry. *Journal of Construction Engineering and Management*, 146(2), 03119009.
- Chalhoub, J. & Ayer, S.K. (2019). Exploring the performance of an augmented reality application for construction layout tasks, *Multimedia Tools and Applications*. Springer US, pp. 1-24. <https://doi.org/10.1007/s11042-019-08063-5>.
- Davies, R. & Harty, C. (2013). Implementing “site BIM”: A case study of ICT innovation on a large hospital project, *Automation in Construction*, 30, pp. 15-24. <https://doi.org/10.1016/j.autcon.2012.11.024>.
- Deng, E.F., Yan, J.B., Ding, Y., Zong, L., Li, Z.X., & Dai, X.M. (2017). Analytical and numerical studies on steel columns with novel connections in modular construction. *Int. J. Steel Struct.* 17 (4), 1613-1626. <https://doi.org/10.1007/s13296-017-1226>.
- Fazel, A. & Izadi, A. (2018). An interactive augmented reality tool for constructing free-form modular surfaces, *Autom. Constr.* 85 135-145, <https://doi.org/10.1016/j.autcon.2017.10.015>.
- Fang, W., Ma, L., Luo, H., Ding, L., & Zhou, A. (2020). Knowledge graph for identifying hazards on construction sites: integrating computer vision with ontology, *Autom. Constr.* 119 103310, <https://doi.org/10.1016/j.autcon.2020.103310>.
- Guo, H., Yu, Y., & Skitmore, M. (2017). Visualization technology-based construction safety management: A review, *Automation in Construction*, 73, pp. 135-144. <https://doi.org/10.1016/j.autcon.2016.10.004>.
- Lee, G., Sacks, R., & Eastman, C.M. (2006). Specifying parametric building object behavior (BOB) for a building information modeling system, *Automation in Construction*, 15(6), pp. 758-776. <https://doi.org/10.1016/j.autcon.2005.09.009>.
- Microsoft. (2023). About HoloLens 2. URL: <https://learn.microsoft.com/en-us/hololens/hololens2-hardware>, accessed December 30, 2024.

Milgram, P. & Kishino, F. (1994). Taxonomy of mixed reality visual displays, *IEICE Transactions on Information and Systems*, E77-D (12), pp. 1321-1329. <https://doi.org/10.1.1.102.4646>.

Mutis, I. & Issa, R.R.A. (2014). Enhancing Spatial and Temporal Cognitive Ability in Construction Education Through Augmented Reality and Artificial Visualizations, in *Computing in Civil and Building Engineering (2014)*, pp. 2079-2086. <https://doi.org/10.1061/9780784413616.258>.

Shanbari, H., Blinn, N., & Issa, R.R.A. (2016). Using augmented reality video in enhancing masonry and roof component comprehension for construction management students, *Engineering, Construction and Architectural Management*, 23(6), pp. 765-781. <https://doi.org/10.1108/ECAM-01-2016-0028>.

Schiavi, B., Havard, V., Beddiar, K., & Baudry, D. (2022). BIM data flow architecture with AR/ VR technologies: use cases in architecture, engineering and construction, *Autom. Constr.* 134, 104054, <https://doi.org/10.1016/j.autcon.2021.104054>.

Thomas, B., Close, B., Donoghue, J., Squires, J., De Bondi, P., & Piekarski, W. (2000). AR Quake: An Outdoor/Indoor Augmented Reality First Person Application, *Personal and Ubiquitous Computing*, 6(1), pp. 75-86. <https://doi.org/10.1007/s007790200007>.

Thomas, B.H. & Sandor, C. (2009). What wearable augmented reality can do for you, *IEEE Pervasive Computing*, 8(2), pp. 8-11. <https://doi.org/10.1109/MPRV.2009.38>.

Trimble. (2024). Mixed reality for construction. URL: <https://www.trimble.com/en/products/building-construction-field-systems/connect-mr>, accessed December 30, 2024.

Wang, X. & Love, P.E.D. (2012). BIM + AR: Onsite information sharing and communication via advanced visualization, in *Proceedings of the 2012 IEEE 16th International Conference on Computer Supported Cooperative Work in Design, CSCWD 2012*. IEEE, pp. 850-855. <https://doi.org/10.1109/CSCWD.2012.6221920>.

Williams, G., Gheisari, M., Chen, P., & Irizarry, J. (2015). BIM2MAR: An Efficient BIM Translation to Mobile Augmented Reality Applications, *Journal of Management in Engineering*, 31(1), p. A4014009. [https://doi.org/10.1061/\(ASCE\)ME.1943-5479.0000315](https://doi.org/10.1061/(ASCE)ME.1943-5479.0000315).

Wang, T.K. & Piao, Y. (2019). Development of BIM-AR-based facility risk assessment and maintenance system. 04019068-2063. *J. Perform. Constr. Facil.* 33 (6). [https://doi.org/10.1061/\(ASCE\)CF.1943-5509.0001339](https://doi.org/10.1061/(ASCE)CF.1943-5509.0001339).

Yan, W., Culp, C., & Graf, R. (2011). Integrating BIM and gaming for real-time interactive architectural visualization, *Automation in Construction*, 20(4), pp. 446-458. <https://doi.org/10.1016/j.autcon.2010.11.013>.

Zollmann, S., Hoppe, C., Kluckner, S., Poglitsch, C., Bischof, H., & Reitmayr, G. (2014). Augmented reality for construction site monitoring and documentation, *Proceedings of the IEEE*, 102(2), pp. 137-154. <https://doi.org/10.1109/JPROC.2013.2294314>.