

**94534/000 | 450 mm**

- 1x300 + 1x150 mm;
- 3x150 mm;

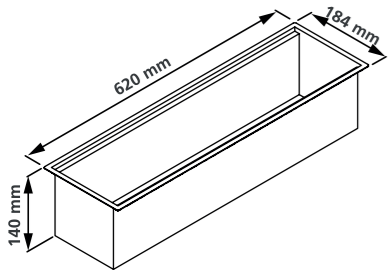

**94534/001 | 600 mm**

- 2x300 mm;
- 1x300 mm + 2x150 mm;
- 4x150 mm\*.

\*necessário repetir acessórios para esta opção / \* necesario repetir accesorios para esta opción / \* It's necessary to repeat accessories for this option

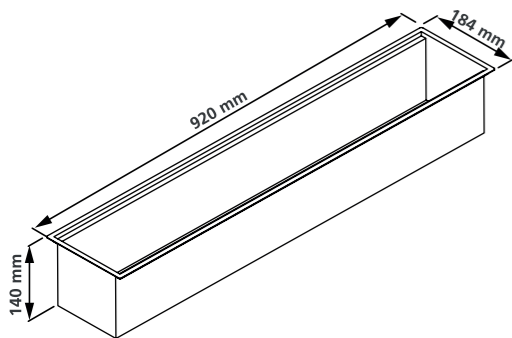

**94534/002 | 900 mm**

- 3x300 mm;
- 2x300 mm + 2x150 mm;
- 1x300 mm + 4x150 mm\*;
- 6x150 mm\*

\*necessário repetir acessórios para esta opção / \* necesario repetir accesorios para esta opción / \* It's necessary to repeat accessories for this option

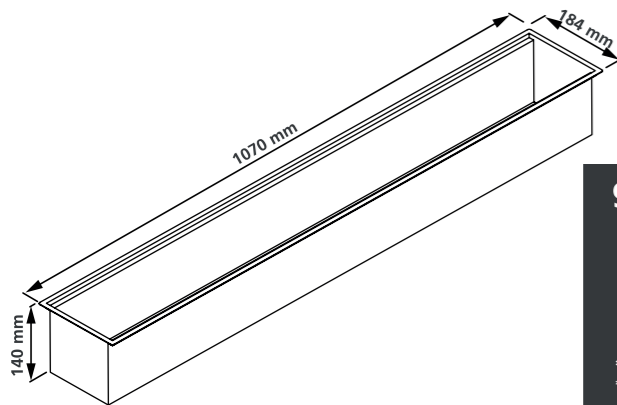

**94534/003 | 1050 mm**

- 3x300 mm + 1x150 mm;
- 2x300 mm + 3x150 mm;
- 1x300 mm + 5x150 mm\*;
- 7x150 mm\*.

\*necessário repetir acessórios para esta opção / \* necesario repetir accesorios para esta opción / \* It's necessary to repeat accessories for this option

**TRAMONTINA**

o prazer de fazer bonito

Rev. 5 - 2021 / 224705

**TRAMONTINA**

**Canal Organizador**  
Canaleta Húmeda / Workstation sink channel

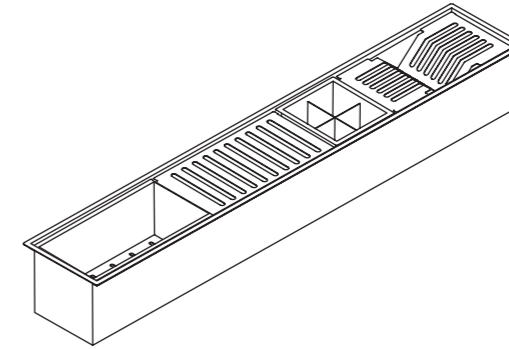

**Acessórios (não inclusos)**

Accesorios (no incluidos) / Accessories (sold separately)

**94534/000 | 450 mm**

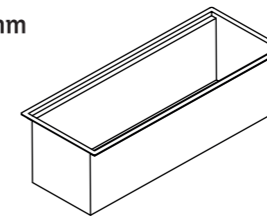

**94534/001 | 600 mm**

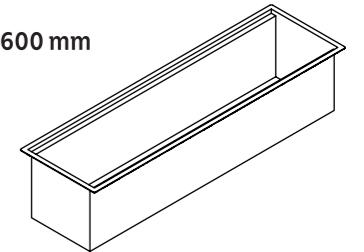

**94534/002 | 900 mm**

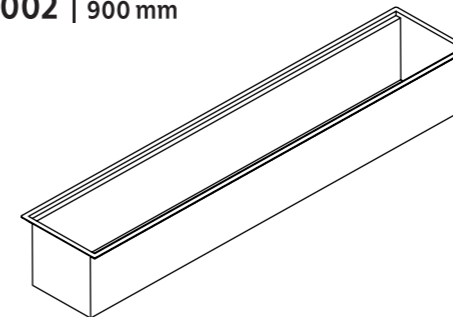

**94534/003 | 1050 mm**

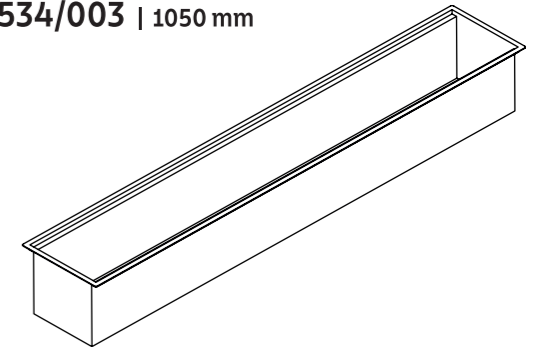

**Acessórios / Accesorios / Accessories**

**Acessórios de 150 mm**

Accesorios de 150 mm / 150 mm accessories



**Acessórios de 300 mm**

Accesorios de 300 mm / 300 mm accessories

Nichos de corte / Nichos de corte / Cutting niches

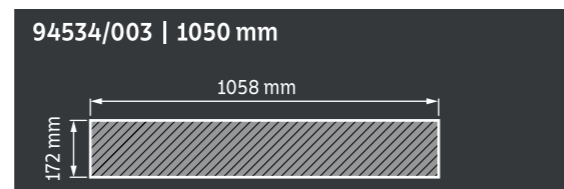
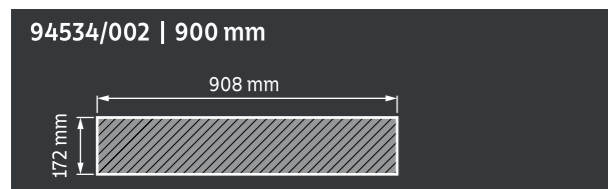
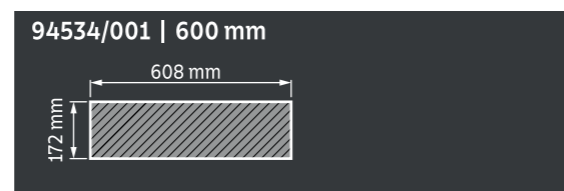
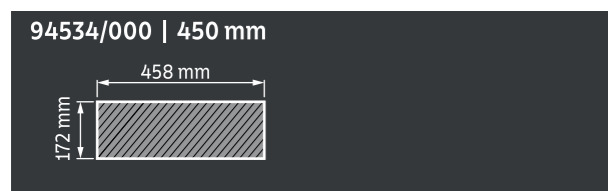

Sugestão de instalação / Sugerencia de instalación / installation suggestion

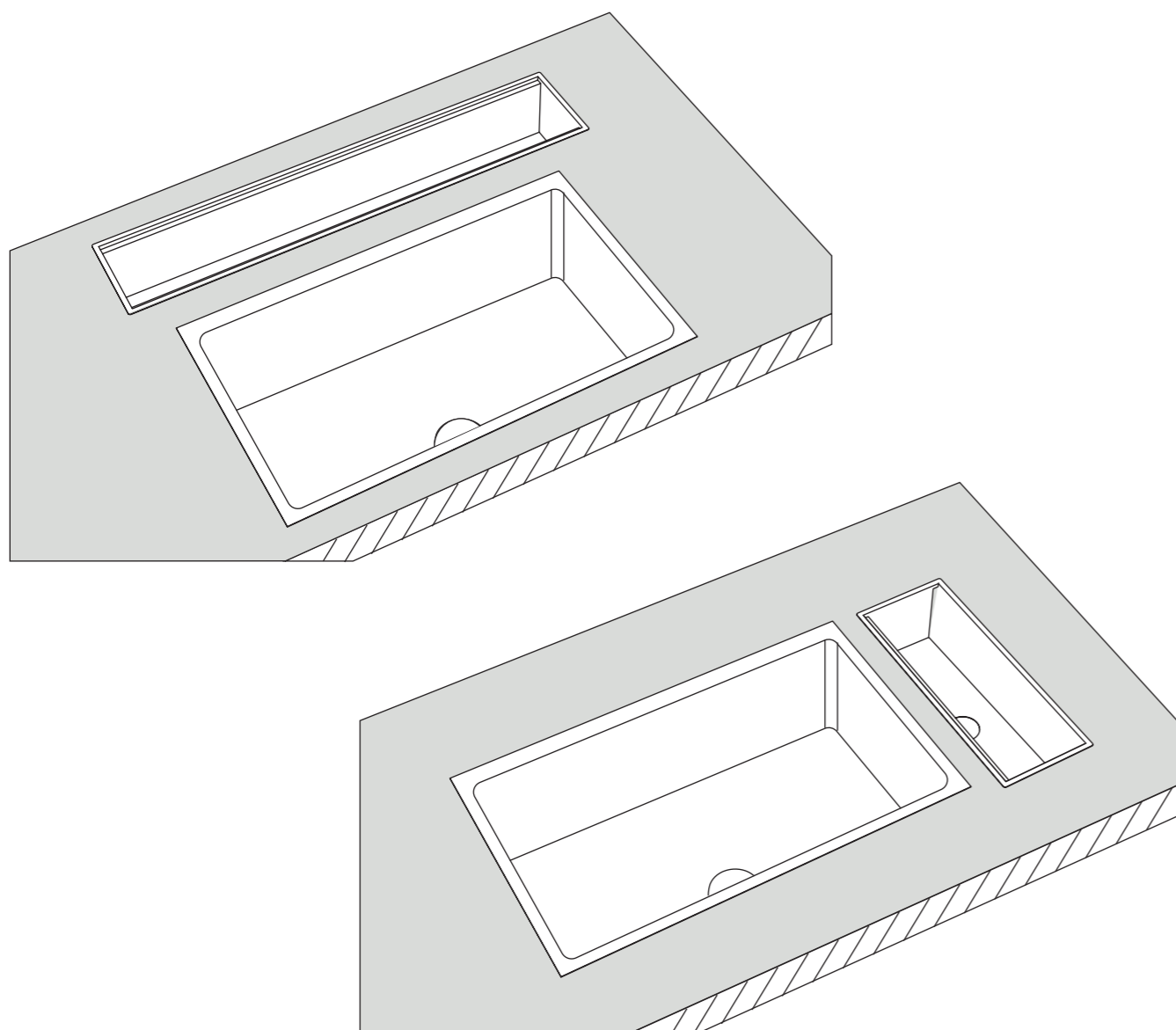

Instalação / Instalación / Installation

Para evitar a passagem de água entre o canal e o tampo é utilizado o adesivo selante a base de PU com densidade entre 30 e 40. O tempo de cura deste adesivo é de 24 horas. Recomenda-se a aplicação nas extremidades da borda do canal, para evitar que o adesivo entre em contato com o interior da peça (para proteger o interior pode-se usar fita crepe). Em seguida o canal é colocado cuidadosamente na posição onde será fixado. Para garantir que não se desloque de sua posição e que toda a borda esteja em perfeito contato com o tampo de granito, pode-se colocar um peso de até 10 Kg sobre o mesmo.

Para evitar el pasaje de agua entre el canal y la mesada, se utiliza el adhesivo sellador a base de PU con densidad entre 30 y 40. El tiempo de cura del adhesivo es de 24 horas. Se recomienda aplicarlo a las extremidades del borde del canal para evitar que el adhesivo entre en contacto con el interior de la pieza (para proteger el interior se puede usar cinta de papel engomada). En seguida se coloca la pileta cuidadosamente en la posición en la que se vaya a fijar. Para garantizar que no se desplace de su lugar y que todo el borde esté en perfecto contacto con la mesada de granito, se puede poner un peso hasta de 10 kg sobre ella.

To prevent water from passing between the organizer and the counter, a PU sealant adhesive with density of between 30 and 40 is used. This adhesive takes 24 hours to set. We recommend applying it on the ends of the edge of the organizer to prevent it from coming into contact with the inner part of the item (you can protect the inner part with masking tape). The workstation sink channel is then carefully placed in the position where it will be fixed. To ensure it doesn't move from this position and that the entire edge is in contact with the granite counter, you can place a load of up to 10kg on the workstation sink channel.

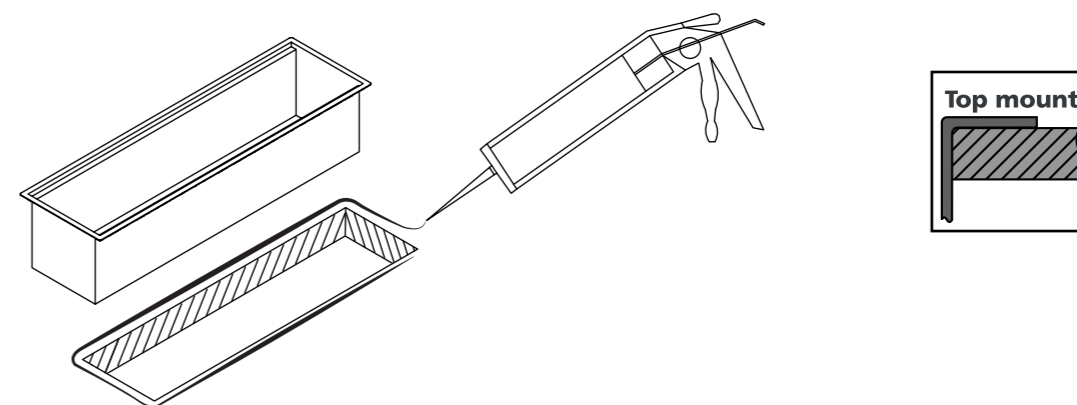

Para garantir a planicidade das bordas, sugere-se o uso de pesos de acordo com o tamanho do canal (indicado abaixo) / To guarantee the flatness of the edges, it is suggested to use weights according to the product size (indicated below) / Para garantizar la planitud de los bordes, se sugiere utilizar pesos de acuerdo con el tamaño del producto (indicado abajo)



Assegure que os pesos estejam apoiados nas bordas externas; Ensure that the weights are supported on the outer edges; Asegúrese de que los pesos sean apoyados en los bordes exteriores;

Certifique-se de que após a colocação dos pesos, a borda esteja mais próxima do tampo; Make sure that after placing the weights, the edge is closer to the counter top.; Asegúrese de que después de colocar los pesos, el borde esté más cerca de la mesada.

Instalação válvula e sifão / Instalación válvula y sifón / Valve and trap installation

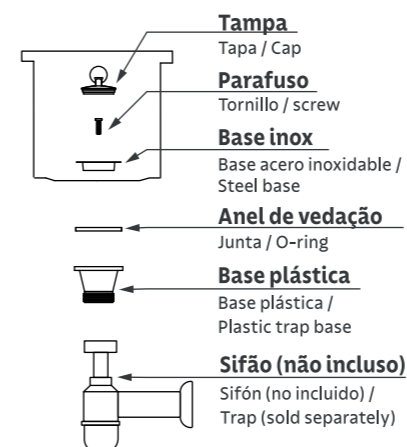

Instalação das válvulas no mesmo sifão  
Instalación de las válvulas en el mismo sifón  
Installation of valves in the same trap

