



**CAPACITOR
COMPETENCE**
since 1958

FILM CAPACITORS

FILM CAPACITORS · DC-LINK

CBB 136 DP SERIES

JIANGHAI EUROPE
Electronic Components GmbH



ENGINEERED SOLUTIONS

v2020.1

FEATURES

- DC-Link
- Very low dissipation factor
- High ripple current capability
- Self-healing
- Long lifetime
- Plastic case

OVERVIEW

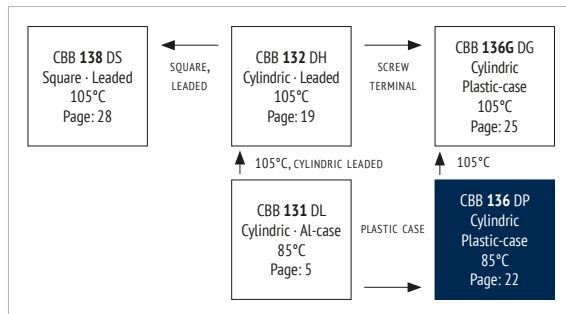

PRODUCT

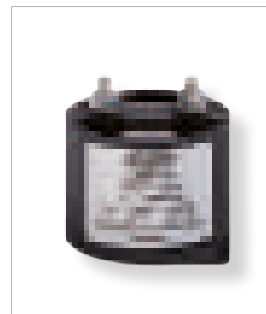

APPLICATIONS

- High power frequency converters
- Motion control, welding equipment, elevators
- Photovoltaic and wind inverters

CHARACTERISTICS

ITEM	CHARACTERISTICS
Climatic Category	40/85/56 (IEC 61071)
Operating Temperature	-40 ~ +85 °C ($\theta_{hotspot} \leq 85$ °C)
Storage Temperature	-40 ~ +85 °C
Rated Voltage U_{RDC}	600 ~ 1.200 V_{DC}
Capacitance Range	60 ~ 645 μF
Capacitance Tolerance	± 10 % (K), ± 5 % (J)
Voltage between Terminals U_{TT}	$1,5 \cdot U_{RDC}$ (20°C, 10 s)
Voltage between Terminals & Case U_{TC}	$\geq 3.000 V_{AC}$ (20°C, 50 Hz, 10 s)
Max. Overvoltage	$1,1 \cdot U_{RDC}$ (30 % of time under load) $1,15 \cdot U_{RDC}$ (30 min. per day) $1,2 \cdot U_{RDC}$ (5 min. per day) $1,3 \cdot U_{RDC}$ (1 min. per day) $1,5 \cdot U_{RDC}$ (max. 30 ms, 100ms per day)
Insulation Resistance R_i °C	$\geq 5.000 M\Omega \cdot \mu F$ (20°C, 100 V_{DC} , 1 min)
Dielectric Dissipation Factor $\tan \delta_o$	$\leq 2 \cdot 10^{-4}$ (20°C, 100 Hz)
Life Time Expectancy	≥ 100.000 h, failure rate ≤ 50 FIT ($\theta_{hotspot} \leq 70$ °C, U_{RDC})
Reference Standard	IEC 61071:2007

ENVIRONMENTAL

The products are RoHS, WEEE and REACh compliant.

The detailed version please see separate "Environmental Certificates" document or www.jianghai-europe.com

APPROVALS

- UL94-V0:**
Plastic & Compound Mass
- UL810:**
CZDS2.E227010 (Construction)

LIFETIME

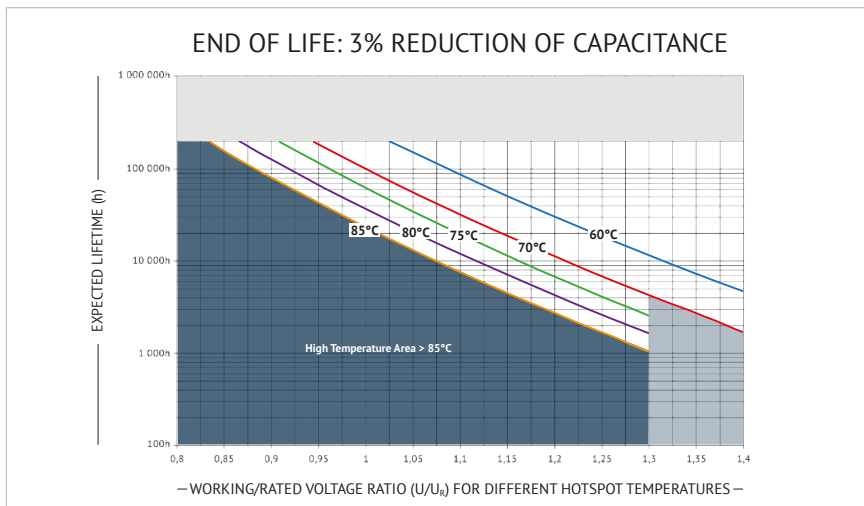

CURRENT DERATING

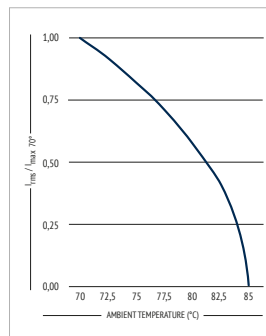

DIMENSIONS

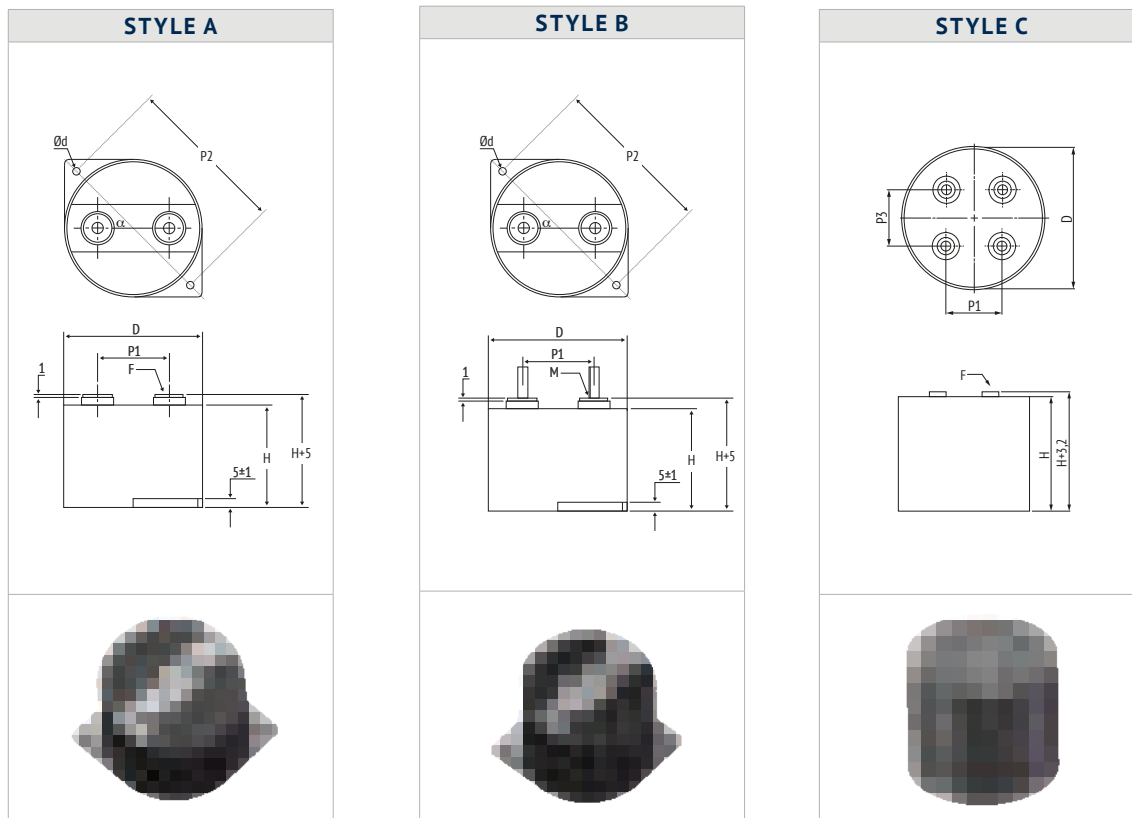

in mm

ØD±1 (mm)	H±1 (mm)	P1 ± 0.5 (mm)	P2 ± 0.5 (mm)	P3 ± 0.5 (mm)	Terminal (mm)		Ød ± 0.5 (mm)
					F Female	M Male	
85	51	45	101	-	M6*10 [order code 0]	M8*20 [order code 3]	5,5
84,5/85	65	45	101	-	M6*10 [order code 0]	M8*20 [order code 3]	5,5
95	83	38	-	38	M6*10 [order code 0]	-	-

$\alpha = 45^\circ\text{C} \pm 2^\circ$

Max. torque for terminals: 5 Nm (M6), 8 Nm (M8)
Max. torque for mounting screws: 3,5 Nm

Other Terminals on request.

INTERNAL CONSTRUCTION

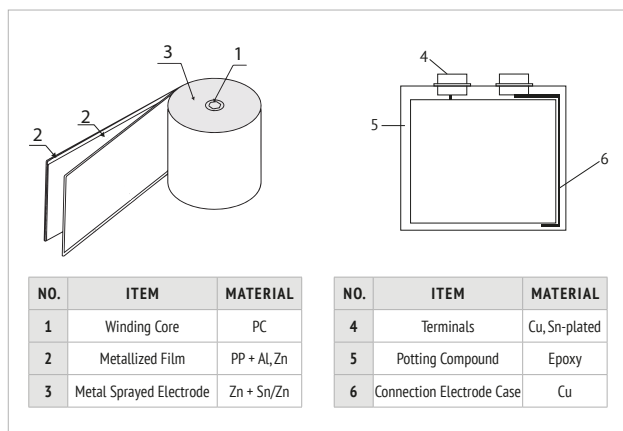

MARKING

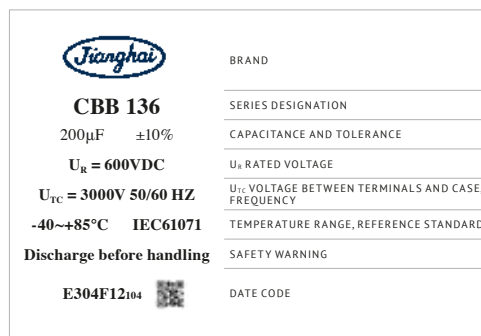

ORDER CODE

FC	C	3A	DP	117	K	K	065	0	4	0	A	1E3
Capacitor type	Product shape	DC rated voltage code (V)	Series code	Capacitance Code Examples (μF)	Capacitance tolerance	Diameter (mm)	Height (mm)	Terminal style	Terminal pitch P ₁ (mm)	Fixed Hole	Style	For internal use
Film Cap. = FC	cylindrical = C	600 2S 800 2K 1000 3A 1200 3B	CBB 136 = DP	50 506 75 756 80 806 110 117 120 127 200 207 220 227 280 287	+5% J ±10% K	84,5 J 85 K 95 W	51 051 65 065 83 083	Female M6*10 0 Male M8*20 3	45 4 38 3	with 0 without 1	Style A A Style B B Style C C	

RATINGS

U _r (V _{DC})	C _r (μF)	I _{max} 70°C, 1kHz (A)	60°C, 1kHz (A)	50°C, 1kHz (A)	≤40°C, 1kHz (A)	I ⁽¹⁾ (A)	R _s 20°C, 1kHz (mΩ)	R _{th} ⁽²⁾ (K/W)	L _s 20°C (nH)	D ±1,0 (mm)	H ±1,0 (mm)	ORDER CODE *# to be defined, see ordering code table
600 2S	200	39	56	69	79	4000	1,2	5,3	≤20	85	51	FCC2SDP207#K051#40#1E3
	280	37	53	65	76	3700	1,4	5,0	≤30	84,5	65	FCC2SDP287#J065#40#1E3
	280	37	53	65	76	3700	1,4	5,0	≤30	85	65	FCC2SDP287#K065#40#1E3
	645	47	68	83	96	4000	0,84	5,2	≤25	95	83	FCC2SDP657#W083#31C1E3
800 2K	120	39	56	69	79	3000	1,2	5,3	≤20	85	51	FCC2KDP127#K051#40#1E3
	220	37	53	65	76	3000	1,4	5,0	≤30	84,5	65	FCC2KDP227#J065#40#1E3
	220	37	53	65	76	3000	1,4	5,0	≤30	85	65	FCC2KDP227#K065#40#1E3
1000 3A	75	36	52	64	73	2400	1,4	5,3	≤20	85	51	FCC3ADP756#K051#40#1E3
	110	34	49	59	69	2300	1,7	5,0	≤30	84,5	65	FCC3ADP117#J065#40#1E3
	110	34	49	59	69	2300	1,7	5,0	≤30	85	65	FCC3ADP117#K065#40#1E3
1200 3B	60	30	43	53	61	1250	2,0	5,3	≤20	85	51	FCC3BDP606#K051#40#1E3
	90	30	43	52	60	2000	2,2	5,0	≤30	85	65	FCC3BDP906#K051#40#1E3

(1) Maximum permissible peak current, (2) Thermal resistance from hotspot to ambient (free convection)

HANDLING PRECAUTIONS

WARRANTY The information contained in this datasheet does neither form part of any quotation nor of a contract, it is believed to be accurate, reliable and up to date. Quality data are based on the statistical evaluations of a large quantity of parts and do not constitute a guarantee in a legal sense. However, agreement on these specifications does mean that the customer may claim for replacement of individual defective capacitors within the terms of delivery. We cannot assume any liability beyond the replacement of defective components. This applies in particular to any further consequences of component failure. Furthermore it must be taken into consideration that the figures stated for lifetime and failure rates refer to the average production status and are therefore to be understood as mean values (statistical expectations) for a large number of delivery lots of identical capacitors. These figures are based on application experience and data obtained from preceding tests under normal conditions, or – for purpose of accelerated aging – more severe conditions. JIANGHAI reserves the right to change these specifications without prior notice. Any application information given is advisory and does not form part of any specification. The products are not primarily designed for use in life supporting applications, devices or systems where malfunction of these products can reasonably be expected to result in personal injury. JIANGHAI customers using or selling these products for use in such applications without prior written consent of JIANGHAI do so at their own risk and agree fully to indemnify JIANGHAI for any damage resulting from such improper use or sale. This version of the datasheet supersedes all previous versions.

NOMINAL CAPACITANCE C_N Nominal Capacitance is defined at 20°C and 50Hz (120Hz).

RATED VOLTAGE U_R, U_N Rated Voltage is the maximum operating peak voltage of either polarity but of a non-reversing type waveform (DC capacitors only), for which the capacitor has been designed, for continuous operation. The Rated Voltage is marked on the capacitor. See also Voltage Derating tables.

RATED AC VOLTAGE U_{RMS} Maximum RMS value for the sinusoidal alternating voltage.

OPERATING VOLTAGE The plastic film capacitor varies in the maximum applicable voltage depending on the applied voltage waveform, current waveform, frequency, ambient temperature (capacitor surface temperature), capacitance value, etc. Be sure to use capacitors within the specified values by checking the voltage waveform, current waveform, and frequency applied to them (In the application of high frequency, the permissible voltage varies with the type of the capacitor. Refer to the specification for details.)

NON-RECURRENT SURGE VOLTAGE U_S Peak voltage induced by a switching or any other disturbance of the system which is allowed for a limited number of times and for durations shorter than the basic period.

- Maximum duration: 50 ms / pulse

- Maximum number of occurrences: 1000 (during load)

MAXIMUM RATE OF VOLTAGE RISE dV/dt Maximum permissible repetitive rate of voltage rise of the operational voltage.

MAXIMUM CURRENT I_{MAX} Maximum Rms Current for continuous operation, see Current Derating tables.

MAXIMUM PEAK CURRENT \hat{I} Maximum permissible repetitive peak current which can occur during continuous operation. $\hat{I} = C_N \cdot (dV/dt)$

MAXIMUM SURGE CURRENT \hat{I}_S

- Maximum duration: 50 ms / pulse

- Maximum number of occurrences: 1000 (during load)

SERIES RESISTANCE R_s Effective ohmic resistance of the conducting elements of the capacitor.

EQUIVALENT SERIES RESISTANCE ESR The ESR represents all ohmic resistances: $ESR = \tan\delta / (\omega C) = R_s + \tan\delta / (\omega C)$

DIELECTRIC DISSIPATION FACTOR $\tan\delta$ Constant dissipation factor of the dielectric material.

LOSS FACTOR $\tan\delta$ The dissipation factor is the ratio between the reactive and effective power.

HOTSPOT TEMPERATURE $\Theta_{HOTSPOT}$ Temperature at the hottest position inside the capacitor. $\Theta_{HOTSPOT} = \Theta_{AMBIENT} + P_{LOSS} \cdot R_{TH}$

R_{TH} : thermal resistance, P_{LOSS} : Powerloss $P_{LOSS} = ESR \cdot I_{RMS}^2$, $\Theta_{AMBIENT}$ = ambient temperature

CHARGING AND DISCHARGING Because the charging and discharging current of capacitor is obtained by the product of voltage rise rate (dV/dt) and capacitance, low voltage charging and discharging may also cause deterioration of capacitor such as shorting and open due to sudden charging and discharging current. When charging and discharging, pass through a resistance of 20Ω/V to 1000Ω/V or more to limit the current. When connecting multiple film capacitors in parallel in withstand voltage test or life test, connect a resistance of 20Ω/V to 1000Ω/V or more in series to each capacitor. In addition, **capacitors must be discharged via a resistor before handling.** Because the capacitors do not have any discharge resistors built-in, there is a risk of residual voltages and electric energy contents that might be dangerous.

OPERATING CURRENT The pulse (or AC) current flowing through the capacitor is expressed as: $\hat{I} = C \cdot dV/dt$. Due to the fact that the dissipation factor of the capacitor is greater than zero, heat will be generated in any application where alternating currents or pulses occur. The resulting internal temperature rise may cause a severe deterioration of the capacitor's withstanding voltage, or may lead to a breakdown (even smoke or fire may result). Therefore, the safe use of capacitor must be within the rated voltage (or category voltage) and the permissible current ranges. The rated current must be considered by dividing into pulse current (peak current) and continuous current (rms current) depending on the break down mode, and when using, should make sure the both currents are within the permissible range.

TEMPERATURE RANGE AND ALTITUDE Use film capacitors only within the specified operating temperature range. The altitude and barometric pressure have an impact on the functionality of the capacitor. Max. Altitude: 2000m above sea level

EXPECTED LIFETIME The expected lifetime of the capacitor depends on the applied voltage and the hot spot temperature during operation. For capacitors applied in different situations, the obtainable average service lives are different. Please refer to the life time diagrams of each series.

FAILURE RATE λ (FAILURE IN TIME FIT) 1 FIT = 1/10⁹h (1 failure per 10⁹ components test hours), $\lambda = r/(nt)$

r = number of failure, n = test number, t = test time

INSULATION VOLTAGE U_i Rms value of AC voltage designed for the insulation between terminals of the capacitor to case or earth. The insulation voltage is equal to the rated voltage of the capacitor, divided by, unless otherwise specified.

INSULATION RESISTANCE R_i Ratio between applied DC Voltage and resulting leakage current after 1 minute of charge. It is defined in MΩ. Typically it is given as time constant $R_i \cdot C$ [μF] in seconds.

VOLTAGE BETWEEN TERMINALS U_{TT} Voltage between terminals.

VOLTAGE BETWEEN TERMINALS AND CASE U_{TC} Voltage between terminals and case.

BUZZING NOISE Any buzzing noise produced by a capacitor is caused by the vibration of the film due to the Coulomb force that is generated between the electrodes with opposite poles. It is of no harm to the capacitor.

SURFACE OVER TEMPERATURE $\Delta\Theta_{CASE}$ When current continuously flow through the capacitor, the temperature inside the capacitor will rise induced by dissipated heat. If the temperature exceeds the maximum allowed hot-spot temperature, it might cause a short circuit or fire. The limits described in the catalogue must not be exceeded and it's necessary to check the temperature on the capacitor's surface in operation.

FLAME RETARDATION Although flame retarding PU resin or plastic case material is used in the coating or encapsulation of plastic film capacitors, continuous exposure to high temperature ambient or fire will break the coating layer or plastic case of the capacitor, and may lead to melting and ignition of the capacitor element.

HUMID AMBIENT If used for a long time in a humid ambient, the capacitor might absorb humidity and oxidize the electrodes causing damage to the capacitor. In case of AC application, high humidity would increase the corona effect. This phenomenon causes a drop in capacitance and an increase of capacitor losses. Humidity needs to be avoided. If needed please inform Jianghai separately for technical adopted components.

STORAGE CONDITIONS 1) Capacitors must not be stored in corrosive atmospheres, particularly not when chlorides, sulfides, alkali, acids, lye, salts, organic solvents or similar substances are present. 2) It must not be stored in high temperature and/or high humidity environments. The following storage conditions must be kept (applicable only for storage in the original package): Temperature: ≤ 35 °C; Humidity: ≤ 80% RH, no dew allowed on the capacitor; Storage time: ≤ 24 months

MOUNTING Other devices, which are mounted near the capacitor, should not touch the capacitor. Additional heat coming from other components near the capacitor may reduce the lifetime of the capacitor. Do never attempt to bend or twist the capacitor after mounting and avoid any mechanical stress on the terminals. Never exceed the max. permissible torques when tightening the terminal screws or the mounting bolt's cap nuts.

CAUTION & WARNINGS Do not touch the terminals of capacitors. The energy stored in capacitors may be lethal. Ensure that the operating environment of the equipment into which the capacitor has been built, is within the specified conditions. Capacitors must not be used in corrosive atmospheres, particularly not when chlorides, sulfides, alkali, acid, lye, salts, organic solvents or similar substances are present. Electrical or mechanical misapplication may be hazardous. Personal injury or property damage may result from bursting of the capacitors or from expulsion of melted material.

Jianghai Europe GmbH, v3 0620

JIANGHAI EUROPE

Electronic Components GmbH



ENGINEERED SOLUTIONS

Customer specific adaptations needed? Please contact JIANGHAI Europe GmbH:
TELEFON: +49 (0) 2151 652088-0 | E-MAIL: INFO@JIANGHAI-EUROPE.COM

5/6
v2020.1

Per visualizzare il catalogo completo siete invitati ad [effettuare il login sul sito](#) oppure ad [effettuare la registrazione gratuita](#).