

RAM PUMPS

Meeting The Toughest Challenges

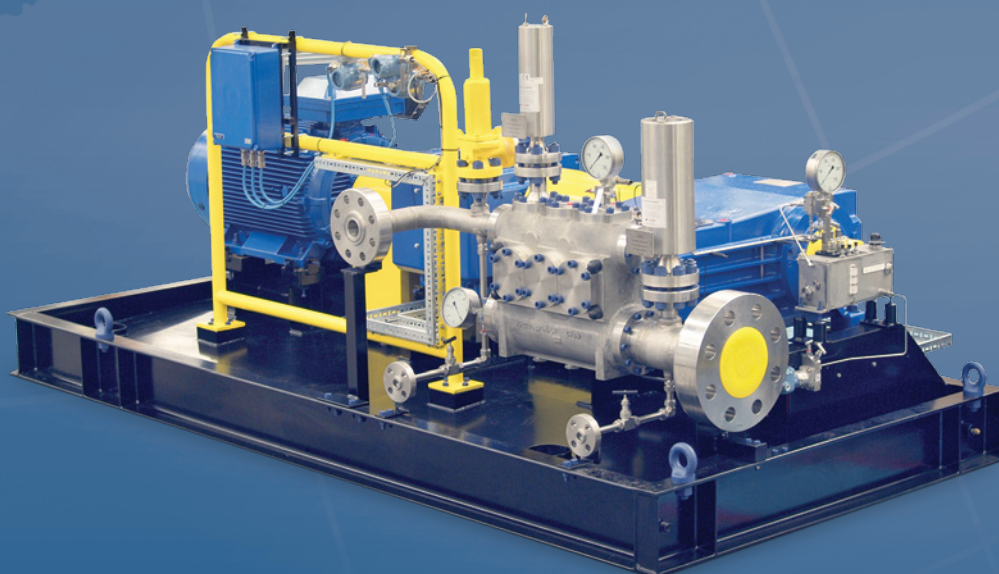

www.rampumps.co.uk

Designed to Stand the Test of Time

Since Ram Pumps Limited was formed in 1972, leading organisations in a variety of industries have placed their trust in the performance of our products. Ram Pumps have earned this worldwide respect by its resolute commitment to building the highest-quality, most dependable high pressure reciprocating pumps and systems available. Every project is managed with the highest degree of professionalism; every product design characteristic is engineered for long-life and dependable performance. More than a just a pump company, Ram Pumps offers a full range of engineering, design, test, and commissioning services. Full system accountability leads to best system performance. Our extensive range of pumps and complete pump systems are custom designed to meet the exact specifications issued by our clients. Our track record of success reflects this attention to detail. With Ramp Pumps, project implementation and product dependability can be counted on, time after time.



Built to Meet the Most Challenging Application Demands

The range of high pressure pumps from Ram Pumps are built to the highest quality standards and custom engineered to meet the requirements of the most demanding industries, including oil and gas (on and off-shore) and chemical processing. Our designs are based on the current American Petroleum Institute Standard 674, being accepted as the industry standard around the world. Our products have a long history of excellence in performance with a no-nonsense philosophy of quality engineering in all areas of construction. Our pumps have an almost infinite variation of build options, owing to over 40 years of experience constructing special purpose pumps and pumping units. Duplex alloy and stainless steel liquid heads are the preferred construction, but many other options are available, including carbon steel, low and high temperature alloys, and Inconel. There are also a variety of packing arrangements that can be fitted to meet your application needs. Typical applications include:

- Chemical Injection
- TEG Circulation
- Slops Transfer
- H2S & Sour Service
- Descaling
- Liquid Condensate Injection
- Well Equalization
- Waste-Water Reinjection
- Boiler Feed
- Hydrocracking
- Gas Dehydration
- Crude Oil Transfer
- LPG / LNG
- Reverse Osmosis
- Drill Cutting Injection
- Hydrostatic Testing
- Gas Corrosion Inhibitor Injection

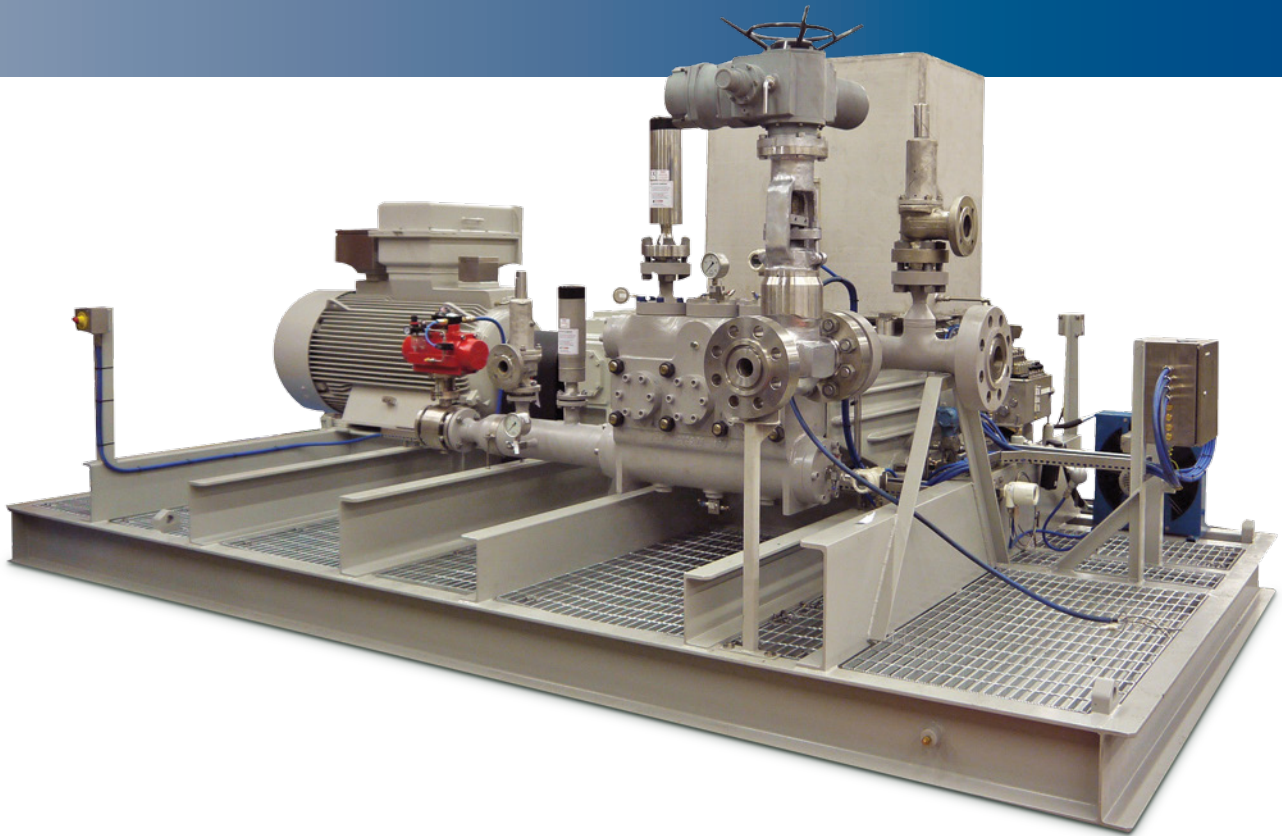

Quality Design and Manufacturing

All of Ram Pumps products are manufactured to meet ISO 9001:2008 specifications. Quality assurance is undertaken in our factory in West Sussex, England which operate under ISO 14001 accreditation for environmental management. A highly experienced Design Engineering Department, using 3D CAD Systems with Integrated and Finite Element Analysis, produces the required drawings and technical information for production.

Our factory is staffed with a team of highly experienced and specialized personnel who take pride in their dedication to the production of a high quality product line, including bare-shaft pumps and custom designed pump units, fully tested and ready for delivery and installation.

Our consistent quality engineering/manufacturing and speedy response to market conditions enable Ram Pumps to meet the exact needs of our clients, who require special purpose, custom designed pumps or pump units. After completing a detailed review of our client's application specifications, we start with our standard pump design and modify to produce a custom pump or pump unit to meet each unique requirement. Special lubricating systems, high temperature packings, special plunger materials and/or special paint finishes are just a few of the custom features available. Utilizing our standard pump design allows us to maintain some of the best delivery available in the industry, while meeting the specialized requirements of the client.

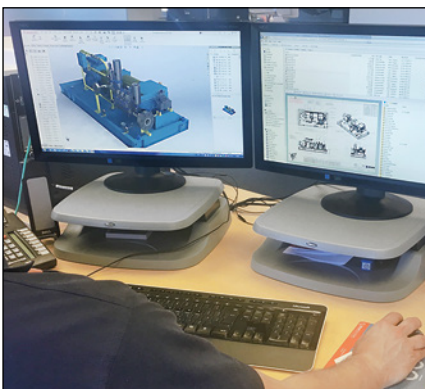

Ram Pump Standard Design Features

Bearings: Large capacity tapered roller bearings offering maximum load bearing support at each end of the crankshaft. Special bearings can be fitted for high stress applications.

Crankshafts: Constructed from high tensile materials suitably heat-treated and processed offering unmatched service life.

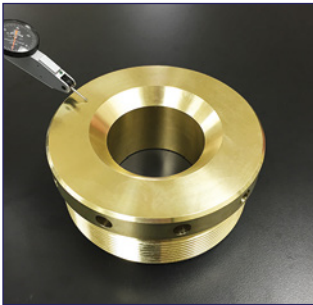

Each component goes through our rigorous QA process confirming our exacting manufacturing standards are met.

Lubrication: Lower capacity pump models feature a splash/submersion lubrication while larger capacity models have a pressure lubrication system, driven directly by the crankshaft of the pump. Additional lubrication options are available throughout the range to meet varying application demands.

Transmissions: All standard pumps are designed with a 'bare shaft' format to allow for a wide variety of transmission types to be used, resulting in a totally flexible product. Low power sizes are available with chassis mounted or special overhead electric motor mount, advantageous where space is at a premium. Ram Pumps also offers a full range of helical and worm gearboxes are offered for use with either electric motors or internal combustion engines.

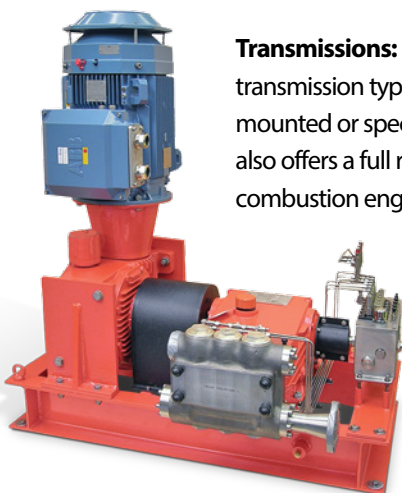
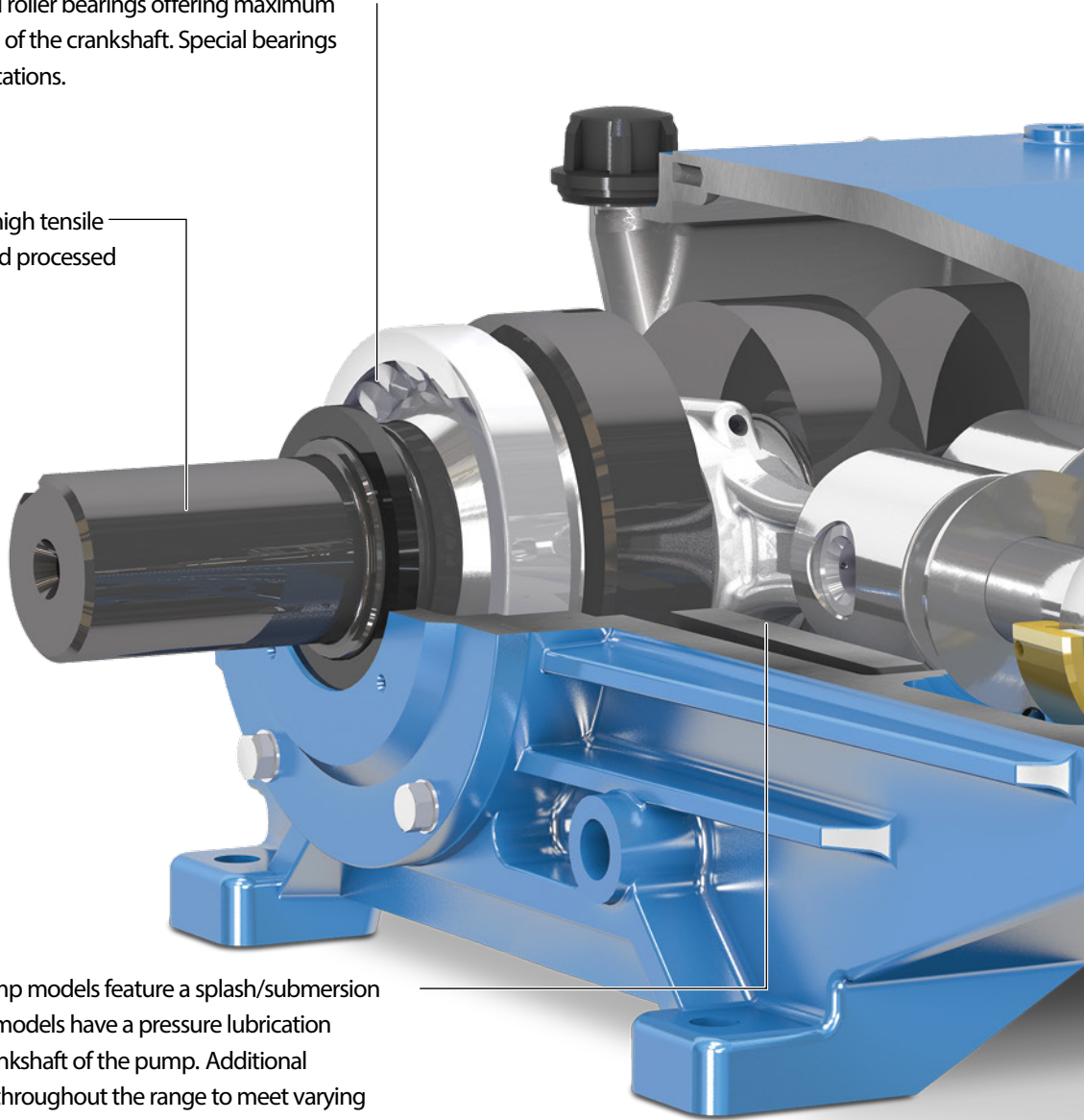

Crankcases: Constructed from S.G. Iron offering exceptional strength, vibration dampening, and flame and spark resistance for hazardous areas. Low temperature grades also available for use in harsh environments.



All raw materials and castings are PMI tested on receipt to validate material specification and ensure the highest quality in each component.

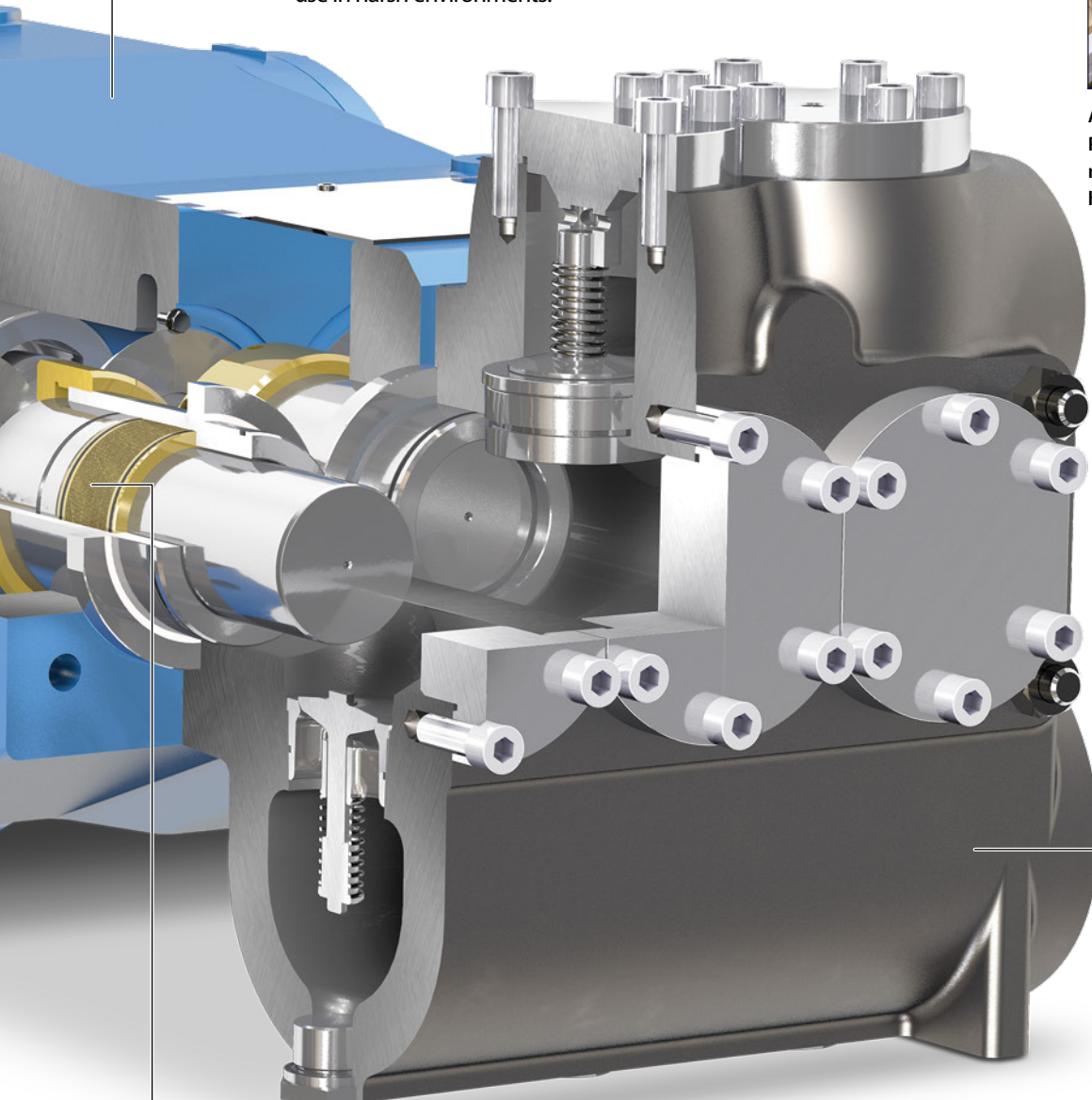

Liquid End: Pressure containing parts are offered in ANSI 316 Stainless Steel, Duplex Alloy 22% or 25% Cr Stainless Steel, or Inconel 625 for a quality product that provides maximum life and a wide range of compatibility.

Plungers and Packings: Considerable laboratory and field testing has gone into the development of our packings and plungers, resulting in outstanding service life and a wide variety of available materials to meet any application demands. Plungers feature rigorous surface finish standards, extending packing life, and are available in a wide range of materials from solid ceramic to tungsten carbide coated. Standard packings are blended PTFE/Kevlar but are also available in a wide selection of materials to best suit your specific application needs.

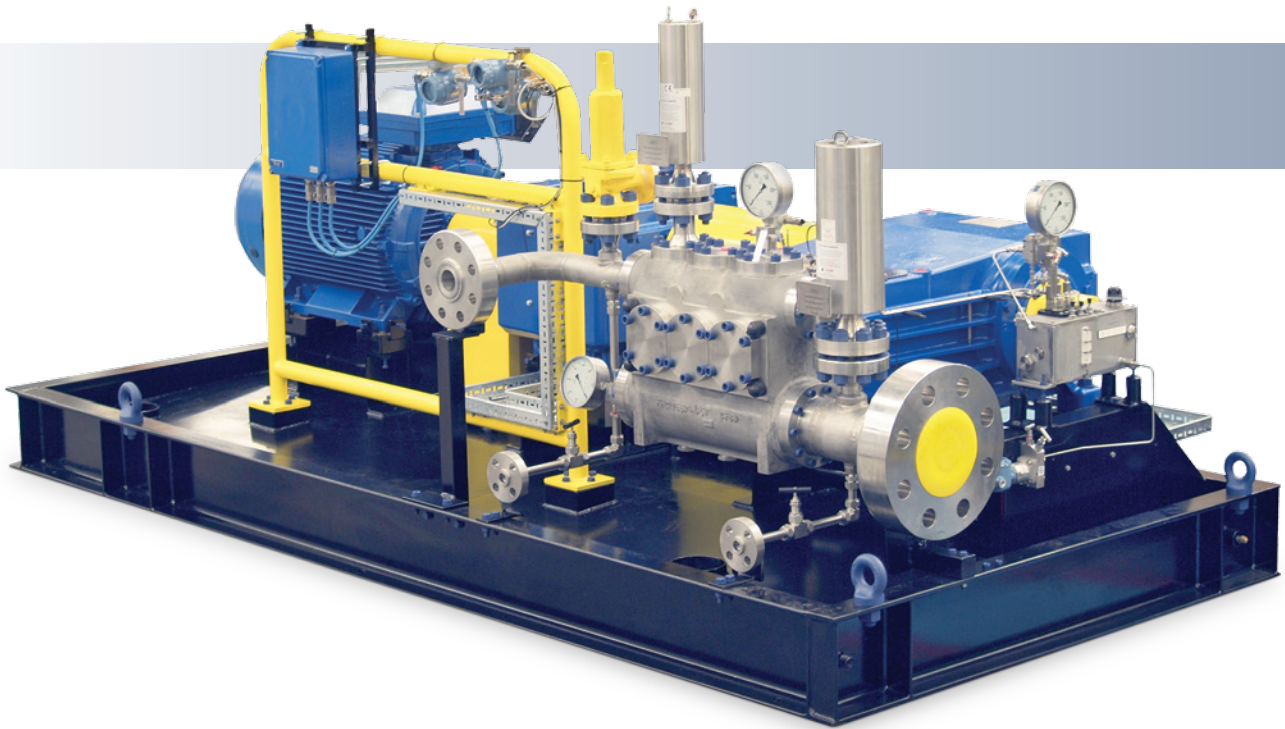

Complete Pumping Solutions

In addition to providing long lasting, high quality pumps, Ram Pumps also offers complete pumping packages, custom tailored to meet your application demands. We use our same rigorous design criteria when manufacturing or selecting additional system components for our pumping packages, ensuring optimum performance and life. Each package is custom designed by our experienced engineering staff to meet your specific requirements as well as environmental standards for zoned, mining and safe area. Popular scope of supply includes:

Motive Power	Transmission	Structural Fabrication	Pump Accessories	Control Systems	Package Solutions
<ul style="list-style-type: none"> · TEFC Electric Motors · DC Motors · Diesel Engines · Petrol Engines · Gas Engines · Steam Turbines 	<ul style="list-style-type: none"> · Gearbox · V Belt / Timing Belt · Internal Gear Sets · Torque Converter · Hydraulic · AC Inverter · DC Drive 	<ul style="list-style-type: none"> · Horizontal Fabrication · Vertical Fabrication · Containerized Packages · Specialist Painting 	<ul style="list-style-type: none"> · Valves · Pulsation Management · Filtration · Lubrication 	<ul style="list-style-type: none"> · Electrical Control · Instrumentation · VSD/VFD Units · PLC Control Systems · Heating & Cooling 	<ul style="list-style-type: none"> · Vibration Management · Sound Control · Pipework Fabrication · Feed & Storage Tank Assemblies · Bespoke Lifting Solutions · Mobile & Trailered Packages



Testing: All pumps and custom designed packages are factory tested at duty point, ensuring full performance acceptance prior to delivery. Utilizing Ram Pumps automated test facility, all performance and environmental data is captured through real time live reporting, which can be presented to customer or third party throughout our detailed witness testing programme. Some of Ram Pumps additional testing capabilities include: NPSH simulation testing, full electrical control string / logic testing and surface coat testing. A comprehensive tailored ITP (Inspection & Test Plan) is supplied with all projects during initial execution, ensuring all critical inspection activities are captured during manufacture/testing.

Additional Corporate Capabilities

Ram Pumps Ltd incorporates a catalog of non-material services to support our project execution, whilst ensuring market leading delivery schedules. In conformance with general industry or customer specification, the below services are provided in full conformance to previously approved procedures.

Inspection and Testing

- Material Certification 3.1, 3.2
- Hydrostatic Testing
- Performance Testing
- PMI Testing
- Mechanical Testing
- NDE - PMI, UT, DP, RT, MPI
- NPSH Testing
- Pulsation Analysis API674
- Mechanical Response Analysis
- ISO 9001 2008 Accredited
- ISO 14001 Accredited
- Supply to ABS, DNV, LR, KR
- Supply to NORSOK standards
- NACE Compliance



Project Services

- Dedicated Project Teams
- In House 3D Design
- FEA Analysis Verification
- Comprehensive Project Documentation
- Automated Document Tracking
- TPI Support Service
- Global Commissioning Service
- On Site Testing Verification
- Onshore / Offshore Engineering Support
- Aftersales & Support Network
- Global Representation
- Comprehensive Warranty Scheme
- Global Logistics Support

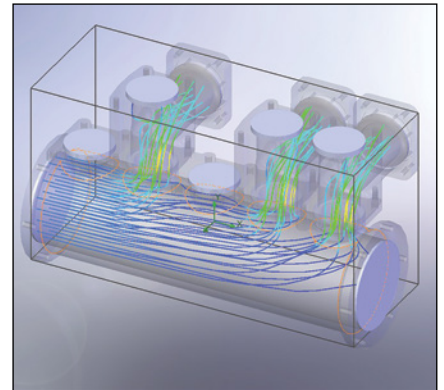

Customer Service and Technical Support

Ram Pumps has highly trained sales and engineering teams available to assist you with all phases of the selection process, from a simple pump selection to a fully customised package solution. Through our extensive experience and direct industry knowledge, presenting the optimum solution remains paramount to ensure not only high quality, but also high customer satisfaction. In addition to direct support, Ram Pumps maintains global coverage of accredited service and support engineers, available for both onshore and offshore support. Service requirements can be scheduled for routine maintenance, emergency response and/or on-site training and support.

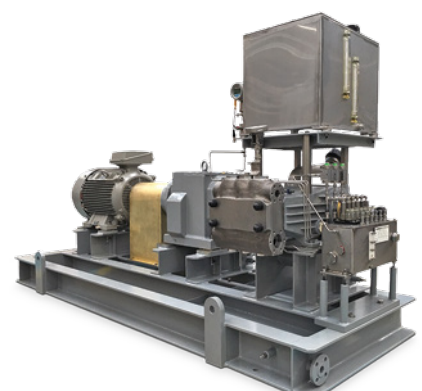
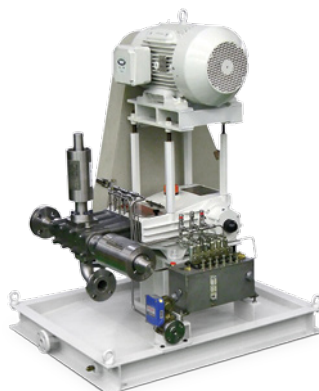

Worldwide Support and Acceptance

Ensuring global support remains a key focus within the Ram Pumps supply. To facilitate this need, regional representation and service support centers can be found in many locations as listed below. All locations are audited and approved routinely by Ram Pumps Ltd. to ensure the optimum effectiveness to our customers.

Locations:

- Egypt
- India
- Indonesia
- Korea
- Kuwait
- Latvia
- Malaysia
- Nigeria
- Norway
- Oman
- Saudi Arabia
- Singapore
- Spain
- Vietnam
- UAE
- United States

Major Clients:

- AMEC
- Amerada Hess
- Aramco
- ADMA / ADCO
- BP
- Conoco
- Fluor
- Foster Wheeler
- GASCO
- Hyundai
- McDermotts
- Petronas
- SABIC
- Saipem
- SEIC
- Shell
- Technip
- Total
- Venture
- Vietsovpetro
- Woodside

Ram Pumps Ltd.

Unit 14, Hazelwood Trading Estate, Worthing, West Sussex, BN14 8NP
Tel: +44 (0) 1903 206622 • Fax: +44 (0) 1903 205511 • www.rampumps.co.uk • Email: sales@rampumps.co.uk