

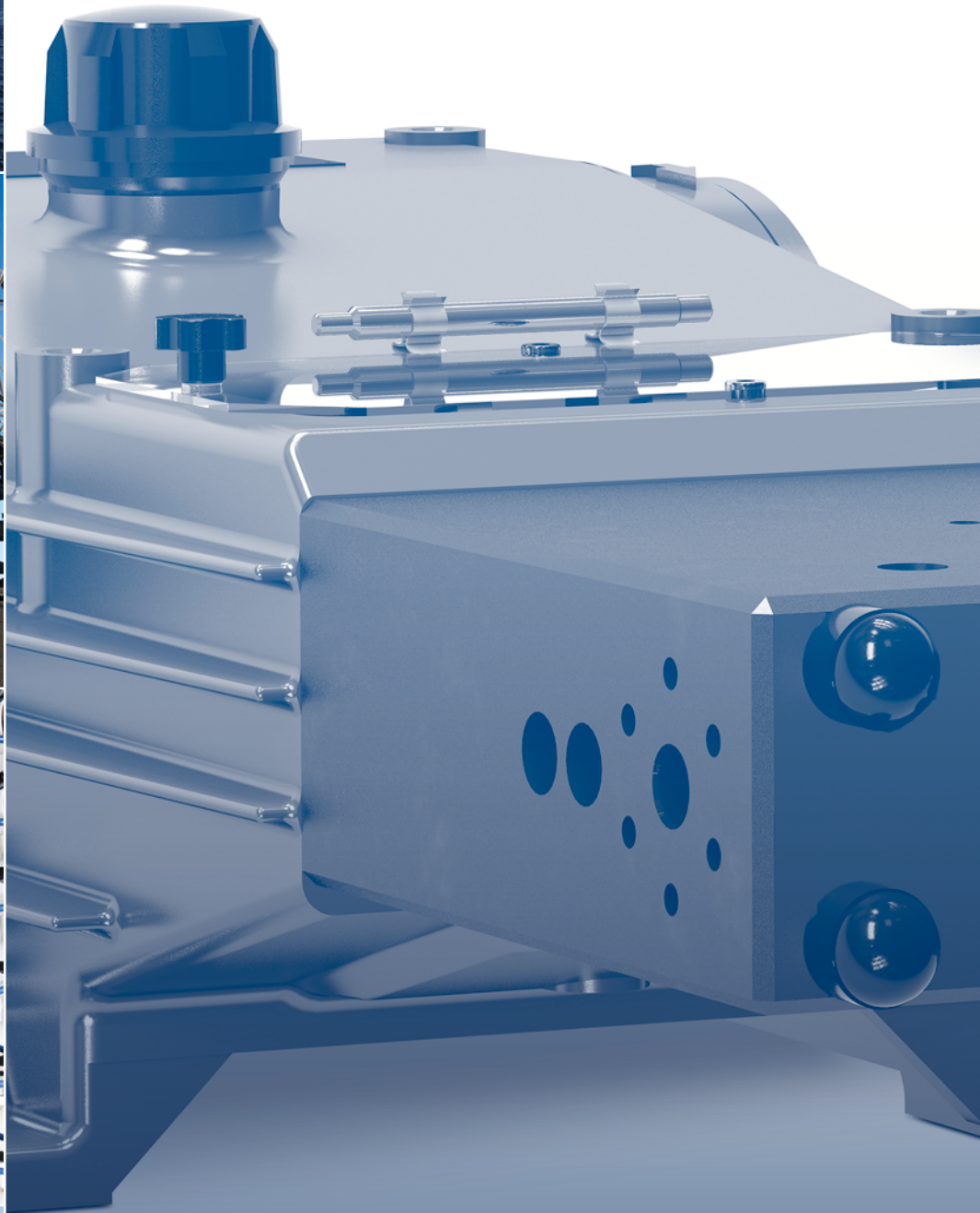

RAM PUMPS

Meeting The Toughest Challenges



75 VHP SERIES

Triplex Plunger Pumps



Quality Products, Exceptional Customer Service

RAM Pumps Ltd.'s portfolio of Triplex & Quintuplex pump packages are designed and manufactured to the highest degree of precision to ensure total reliability and durability is maintained throughout our range.

RAM Pumps design is in full compliance to API674 along with most industry standards including, ISO 9001/2008, ATEX, EC P.E.D., NACE, Norsok, and GOST. These standards are rigorously maintained to ensure complete inclusion into the most arduous and demanding applications worldwide.

RAM Pump's commitment to flexible design and scope conformance has supported the evolution of a truly comprehensive supply. Including such auxiliary options as:

- Self-driven lubrication systems for both drive and seal arrangements.
- Condition monitoring to customer expectation and specification
- Multiple drive options and adaptations
- Direct mounting of dampers, PVS's etc. to the process fluid end for maximum effectiveness.

Common Applications Include:

Oil and Gas

Glycol Injection or
Regeneration
Methanol Injection
Hydrocarbon Condensate
Hydro Test

Water Production

Drill Cutting Re-Injection
Miscible Gas Injection
Fracking
Liquid Condensate
Injection

Reverse Osmosis

Desalination
Food Processing
Pharmaceuticals

Industrial

Water Jetting
De-Scaling
Boiler Feed

Quality Focused Design and Manufacturing

High quality taper roller bearings ensure extended operation and improved load transfer with the ability to accommodate higher axial forces

Precision ground and hardened carbon steel crankshaft designed continual service

Solid valve arrangements with specific process wetted material selection

Fluid head castings and materials all supplied from UK & European foundries operating to ISO, ABS, LR and DNV Standards

Splash & submersion lubrication or forced drive lubrication option available

Packing sets are designed for each specific operation. Additional options can be incorporated including:

- Packing lubrication
- Seal flush
- Self energising seal sets
- Leak detection and monitoring

Plungers are hard-faced Ni-Cr coated for sustained operation at varying temperatures, extending packing life whilst minimizing corrosion. Additional materials available to meet application requirements

RAM 75 VHP PERFORMANCE

Bore	Stroke	Max RPM (API)	Max RPM (Non API)	Max Flow (API) lpm / gpm	Max Flow (Non-API) lpm / gpm
35	80	400	450	88 / 23.2	99 / 26.1
30	80	400	450	64 / 17	73 / 19.2
25	80	400	450	45 / 11.8	50 / 13.3
20	80	400	450	29 / 7.6	32 / 8.5

MAXIMUM PRESSURES		
Material	BAR G	PSI
Carbon Steel WCB	441	6,396
Carbon Steel Gr 90 60	1,121	16,259
316 Stainless Steel	360	5,221
Duplex 22% CR	737	10,689
Super Duplex 25% Chrome	800	11,603
Inconel 625	800	11,603

*Maximum absorbed power rating for the Ram 75 VHP Series is 65 kW – Please ensure specific application data is calculated to determine maximum absorbed power required.

Dimensional Drawing

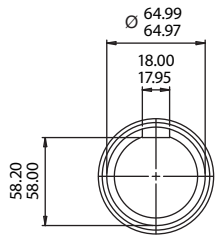

SHAFT END DETAIL

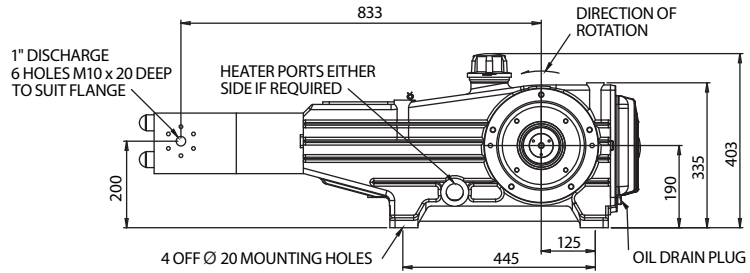
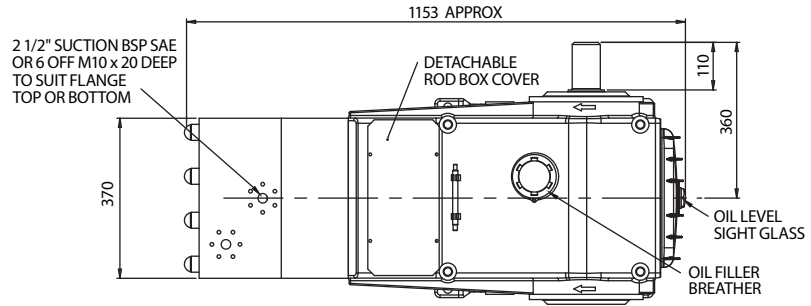
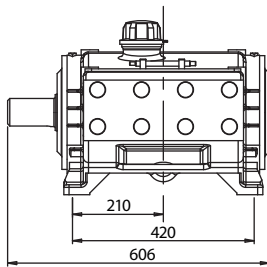

Standard Supply Scope

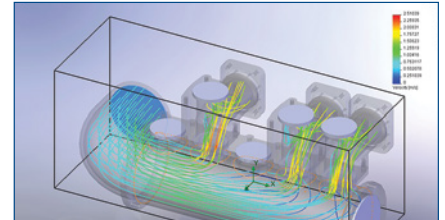
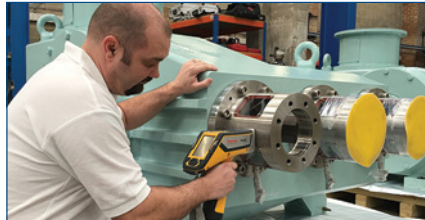
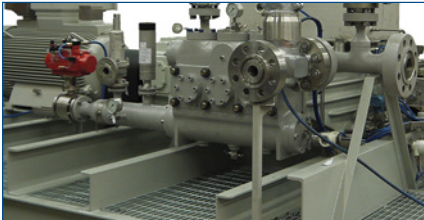

Packaged Equipment

- Motors & Drives
- Diesel / Gas Engines
- Transmission
- Structural Fabrication
- Pulsation Management
- Valves & Filtration
- Instrumentation
- Electrical Control
- Lubrication Systems
- VSD / VFD Units
- PLC Control Systems
- Heating & Cooling
- Specialist Painting

Inspection & Testing

- Material Certification 3.1, 3.2
- Hydrostatic Testing
- Performance Testing
- Mechanical Testing
- NDE - PMI, UT, DP, RT, MPI
- NPSH Testing
- Pulsation Analysis API674
- Mechanical Response Analysis
- ISO 9001 2008 Accredited
- ISO 14001 Accredited
- Supply to ABS, DNV, LR, KR
- Supply to NORSOK Standards
- NACE Compliance

Project Services

- Dedicated Project Teams
- In House 3D Design
- FEA Analysis Verification
- Comprehensive Project Documentation
- Automated Document Tracking
- TPI Support Service
- Global Commissioning Service
- On Site Testing Verification
- Onshore / Offshore Engineering Support
- Aftersales & Support Network
- Global Representation
- Comprehensive Warranty Scheme
- Global Logistics Support

Ram Pumps Ltd.

Unit 14, Hazelwood Trading Estate, Worthing, West Sussex, BN14 8NP
 Tel: +44 (0) 1903 206622 • Fax: +44 (0) 1903 205511 • www.rampumps.co.uk • Email: sales@rampumps.co.uk