

**Official Title:** A Phase 3, Open-Label, Single-Arm Study To Evaluate The Efficacy And Safety Of BMN 270, An Adenovirus-Associated Virus Vector-Mediated Gene Transfer Of Human Factor VIII In Hemophilia A Patients With Residual FVIII Levels  $\leq$  1 IU/dL Receiving Prophylactic FVIII Infusions

**NCT Number:** NCT03370913

**Applicant/MAH:** BioMarin Pharmaceutical Inc.

**Version Date:** 15 Jul 2021

---

## Note to File (NTF)

|                                      |  |
|--------------------------------------|--|
| <b>Project No.:</b>                  | BMN 270; Study 270-301   |
| <b>Project Name (If Applicable):</b> | To align the 270-301 Protocol (version 7.0, 15 July 2021; US-specific) and the 2-year analysis SAP (version 2.0, 13 December 2021) with the 2-year 270-301 CSR   |
| <b>Location:</b>                     | NA   |
| <b>Subject:</b>                      | NTF to bridge the 270-301 protocol (version 7.0, 15 July 2021; US-specific) and the 2-year analysis SAP (version 2.0, 13 December 2021) with the 2-year 270-301 CSR for primary and secondary endpoints and other changes made to the 2-year analyses. |
| <b>Date</b>                          | 02 March 2023  |

**Overserved Discrepancy** – Primary and secondary endpoints and statistical analysis methods used in the 2-year 270-301 CSR were modified from those specified in the effective versions of the 270-301 protocol (version 7.0, 15 July 2021; US-specific) and the 2-year analysis SAP (version 2.0, 13 December 2021).

**Background** – The 2-year analysis of Study 270-301 was performed in January 2022 based on pre-specified analysis methods in the 2-year analysis SAP. Type B Pre-BLA feedback was received from FDA on 16 May 2022. FDA requested changes to the analysis methods, including primary and secondary endpoints. The results reported in 2-year 270-301 CSR reflect the modified analysis methods per FDA feedback and this CSR was submitted to the FDA on 29 September 2022, in the BLA re-submission. Changes from the planned analysis methods were documented in Section 9.8.2 of the CSR (Changes to Planned Analyses).

**Solution** – This NTF serves as a bridging document between the analysis methods in the 270-301 protocol (version 7.0, 15 July 2021; US-specific), the 2-year analysis SAP (version 2.0, 13 December 2021) and the 2-year 270-301 CSR.

The table below outlines all the changes made to the 2-year analysis methods, including primary and secondary endpoints

| <b>Changes to planned 2-yr Analyses for 270-301 based on FDA feedback</b> |   |   |   |
|---|---|---|---|
|   | <b>270-301 Protocol (version 7.0, 15 July 2021; US-specific)</b>  | <b>2-year Analysis SAP (version 2.0, 13 December 2021)</b>  | <b>270-301 2-Year CSR (in response to FDA Feedback)</b>   |
| Primary and secondary efficacy endpoints                                  | Primary <ul style="list-style-type: none"> <li>• ABR (treated bleeds)</li> </ul> Secondary <ul style="list-style-type: none"> <li>• FVIII activity</li> <li>• FVIII utilization</li> </ul> (If discrepancies exist in statistical methods between the SAP and the study protocol, the SAP will prevail) | Primary <ul style="list-style-type: none"> <li>• ABR (treated bleeds)</li> </ul> Secondary <ul style="list-style-type: none"> <li>• FVIII activity</li> <li>• FVIII utilization</li> <li>• ABR (all bleeds)</li> <li>• Haemo-QoL-A Total score</li> <li>• Haemo-QoL-A Physical Functioning domain score</li> <li>• Haemo-QoL-A</li> </ul> | Primary <ul style="list-style-type: none"> <li>• ABR (all bleeds)</li> </ul> Secondary <ul style="list-style-type: none"> <li>• ABR (treated bleeds)</li> <li>• FVIII activity</li> <li>• FVIII utilization</li> <li>• Haemo-QoL-A Total score</li> <li>• Haemo-QoL-A Physical Functioning domain score</li> <li>• Haemo-QoL-A Consequences of bleeding domain score</li> </ul> |

|  |  |  |  |
|--|--|--|--|
|  |  | <p>Consequences of bleeding domain score</p> <ul style="list-style-type: none"> <li>Haemo-QoL-A Role functioning domain score</li> </ul> | <ul style="list-style-type: none"> <li>Haemo-QoL-A Role functioning domain score</li> </ul>  |
| Hypothesis testing   | <p>Hierarchical testing will be performed in the order of endpoints as shown above, each at the alpha level of 0.0498.</p> <p>(If discrepancies exist in statistical methods between the SAP and the study protocol, the SAP will prevail)</p> | <p>Hierarchical testing will be performed in the order of endpoints as shown above, each at the alpha level of 0.05.</p>                 | <p>At the time of receipt of FDA WRO feedback, the outcomes of the SAP-specified hypothesis testing were known to the Sponsor</p> <p>- all statistically significant at the alpha level of 0.05. By considering ABR (all bleeds) as the primary efficacy endpoint, the revised analyses will simply present the study results with p-values to show statistical significance on each endpoint.</p>   |
| Ranking of secondary efficacy endpoints  | <p>Secondary efficacy endpoints are ranked in hypothesis testing order as shown above.</p> <p>(If discrepancies exist in statistical methods between the SAP and the study protocol, the SAP will prevail)</p>                                 | <p>Secondary efficacy endpoints are ranked in hypothesis testing order as shown above.</p>   | <p>Secondary efficacy endpoints are not ranked, and their results will be presented one by one.</p>  |
| Sensitivity analysis: impact of exogenous FVIII product use in the efficacy evaluation period (EEP) on ABR | --   | Not planned  | <p>The following sensitivity analyses will be performed by counting exogenous FVIII product use in EEP as bleeding events:</p> <ul style="list-style-type: none"> <li>#1: count each one-time FVIII prophylaxis use in EEP as one bleed</li> <li>#2: count each one-time or routine FVIII prophylaxis use in EEP as one bleed</li> </ul> <p>#3: count each one-time or routine FVIII prophylaxis use and each surgery/procedure that had FVIII use in EEP as one bleed</p> |
| Additional sensitivity analysis: impact of IS on ABR and FVIII activity                                    | --   | Not planned  | <p>The following sensitivity analyses will be performed in subjects who have been off IS for at least 12 months</p> <ul style="list-style-type: none"> <li>Repeat the primary analysis of ABR (ABR</li> </ul>  |

|  |                   |   |   |
|--|-------------------|---|---|
|  |                   |   | change from baseline) in this subgroup<br>Repeat the primary analysis of FVIII activity (FVIII activity change from baseline at Week 104) in this subgroup  |
| Washout period between the last dose of FVIII prophylaxis following gene therapy and the start of EEP  | No washout period | 3 days  | Based on the half-life of the original FVIII prophylaxis product: <ul style="list-style-type: none"> <li>• 3 days for standard half-life or plasma-derived products</li> <li>• 5 days for extended half-life</li> </ul>   |
| Definition of AEs/SAEs related to IS   | --                | All AEs/SAEs during or within 2 weeks' post-IS use  | All AEs/SAEs following IS use up to each subject's last visit for the analysis  |
| IS (CS or AIS) therapy to be included in the analysis  | --                | Systemic IS (CS or AIS) indicated for ALT elevation of any duration, or indicated for other purposes with a duration of at least 4 weeks                                    | Systemic IS (CS or AIS) indicated for any purpose of any duration   |
| Definition of an IS course (cycle)   | --                | The start of an IS use through the end of taper or increase in IS dose for $\geq 2$ consecutive weeks preceded by at least 2 decreases in IS dose, whichever occurs earlier | The time period between the first day of starting an IS therapy to the last day of IS use. Any increase in the dose of IS will be considered as a new cycle of IS therapy with the first day of increase of IS dose constituting as the start day of a new cycle. |
| <b>Comment(s)/ Recommendation(s):</b><br>This NTF serves as a bridging document between the analysis methods in the 270-301 protocol (version 7.0, 15 July 2021; US-specific), the 2-year analysis SAP (version 2.0, 13 December 2021) and the 2-year 270-301 CSR. |                   |   |   |

DocuSigned by:  
**PI**  
 Signer Name: **PI**  
 Signing Reason: I approve this document  
 Signing Time: 16-Mar-2023 | 5:35 PM PDT  
 934DEBF504AB4E6A83363FE5BE488D5F

16-Mar-2023 | 5:35 PM PDT

**PI**, MD, PhD  
**PI**, Clinical Sciences  
 BioMarin Pharmaceutical Inc.



DocuSigned by:

PI [redacted]



Signer Name: PI [redacted]

Signing Reason: I approve this document

Signing Time: 03-Apr-2023 | 3:41 PM PDT

B1398DCC24584CC09F81779CE571B4C0

---

PI [redacted]

PI [redacted], Statistical Science

BioMarin Pharmaceutical Inc.

DocuSigned by:

PI [redacted]



Signer Name: PI [redacted]

Signing Reason: I approve this document

Signing Time: 03-Apr-2023 | 10:37 AM PDT

C9D2B4CC86DF47D5B0C4467D11AE8341

---

PI [redacted]

PI [redacted], Regulatory Affairs

BioMarin Pharmaceutical Inc.



**CLINICAL STUDY PROTOCOL**

**Study Title:** A Phase 3 Open-Label, Single-Arm Study To Evaluate The Efficacy and Safety of BMN 270, an Adeno-Associated Virus Vector-Mediated Gene Transfer of Human Factor VIII in Hemophilia A Patients with Residual FVIII Levels  $\leq 1$  IU/dL Receiving Prophylactic FVIII Infusions

**Protocol Number:** 270-301

**Active Investigational Product:** AAV5-hFVIII-SQ

**IND/European Union Drug Regulating Authorities Clinical Trials (EudraCT) Number:** 2017-003215-19  
IND #: 017659

**Indication:** Hemophilia A

**Sponsor:** BioMarin Pharmaceutical Inc.  
105 Digital Drive  
Novato, CA 94949

**Development Phase:** Phase 3

**Sponsor's Responsible Medical Monitor:** PI [REDACTED] MD, MPhil  
PI [REDACTED]  
BioMarin Pharmaceutical Inc.  
105 Digital Drive  
Novato, CA 94949

**Duration of Subject Participation:** Approximately 264 weeks

**Dose:** 6E13 vg/kg

**Study Population:** Males aged 18 or older

**Date of Original Protocol:** 14 August 2017

Property of BioMarin  
**CONFIDENTIAL**

May not be divulged, published, or otherwise disclosed to others without prior written approval from BioMarin.

This study will be conducted according to the principles of Good Clinical Practice as described in the U.S. Code of Federal Regulations and the International Conference on Harmonisation Guidelines, including the archiving of essential documents

|                 |         |        |
|-----------------|---------|--------|
| <b>B:OMARIN</b> | 270-301 | Page 2 |
|-----------------|---------|--------|

## 2 SYNOPSIS

|  |  |   |
|--|--|---|
| <b>NAME OF COMPANY</b><br>BioMarin Pharmaceutical Inc.<br>105 Digital Drive<br>Novato, CA 94949<br><br><b>NAME OF FINISHED PRODUCT:</b><br>BMN 270<br><br><b>NAME OF ACTIVE INGREDIENT:</b><br>AAV5-hFVIII-SQ  | <b>SUMMARY TABLE</b><br>Referring to Part of the<br>Dossier:<br><br>Volume:<br><br>Page:<br><br>Reference: | <b>FOR NATIONAL<br/>         AUTHORITY USE<br/>         ONLY:</b> |
| <b>TITLE OF STUDY:</b><br>A Phase 3 Open-Label, Single-Arm Study To Evaluate The Efficacy and Safety of BMN 270, an Adeno-Associated Virus Vector-Mediated Gene Transfer of Human Factor VIII in Hemophilia A Patients with Residual FVIII Levels $\leq 1$ IU/dL Receiving Prophylactic FVIII Infusions  |  |   |
| <b>PROTOCOL NUMBER:</b><br>270-301   |  |   |
| <b>STUDY SITES:</b><br>Approximately 30 sites worldwide.   |  |   |
| <b>PHASE OF DEVELOPMENT:</b><br>Phase 3  |  |   |
| <b>STUDY RATIONALE:</b><br><p>Hemophilia A (HA) is an X-linked recessive bleeding disorder that affects approximately 1 in 5,000 males. It is caused by deficiency in the activity of coagulation factor VIII (FVIII), an essential cofactor in the intrinsic coagulation pathway. This disorder can be either inherited, due to a genetic aberrancy, or an acquired immunologic process, leading to insufficient quantities of FVIII or a dysfunctional FVIII, but all are characterized by a defective coagulation process. The clinical phenotype of HA patients generally correlates tightly with the level of residual expression. Severe HA is classified as FVIII activity less than 1% of wild-type (<math>&lt; 1</math> IU/dL), moderate disease comprises 1-5% of wild-type activity and the mild form is 5-40% activity. The clinical manifestations of severe HA are frequent spontaneous bleeding episodes, predominantly in joints and soft tissues, with a substantially increased risk of death from hemorrhage when the brain is involved. Subjects with moderate disease can exhibit manifestations similar to those seen in patients with severe HA, resulting in a comparable bleeding phenotype.</p> <p>Treatment of severe HA presently consists of intravenous injection of plasma-derived or recombinant human FVIII protein (rhFVIII) concentrates, both as prophylaxis 2-3 times per week, and at the time of a bleed, to prevent or control bleeding episodes, respectively. The half-life for FVIII (12 to 18 hours for most approved products) necessitates frequent infusions, and although a major advance in the treatment of HA, it remains common for severe HA patients to continue to have multiple bleeding events on prophylactic therapy (median ABR of 1-4 with prophylaxis treatment in a recently published retrospective observational study (<a href="#">Berntorp, 2016, Haemophilia</a>) and between 1-2 in 6 prospective FVIII interventional studies) and on-demand-only therapy (median ABR of 4.5-18 in a recently published retrospective study (<a href="#">Berntorp, 2016,</a></p> |  |   |

|                 |         |        |
|-----------------|---------|--------|
| <b>B:OMARIN</b> | 270-301 | Page 3 |
|-----------------|---------|--------|

| <b>NAME OF COMPANY</b><br>BioMarin Pharmaceutical Inc.<br>105 Digital Drive<br>Novato, CA 94949  | <b>SUMMARY TABLE</b><br>Referring to Part of the<br>Dossier:<br><br>Volume:<br><br>Page:<br><br>Reference: | <b>FOR NATIONAL<br/>AUTHORITY USE<br/>ONLY:</b> |
|--|--|---|
| NAME OF FINISHED PRODUCT:<br>BMN 270   |  |   |
| NAME OF ACTIVE INGREDIENT:<br>AAV5-hFVIII-SQ   |  |   |
| <p><a href="#">Haemophilia</a>) and between 20-60 in 6 prospective FVIII interventional studies). The consequence of multiple bleeding events is the development of debilitating multiple-joint arthropathy and substantially increased risk of death. Chemical modification (eg, direct conjugation of polyethylene glycol (PEG) polymers) and bioengineering of FVIII (eg, FVIII-Fc fusion proteins) improve half-life by approximately 50%, and thus, show promise in reduced dosing and maintaining activity levels above a 1% trough for a greater proportion of the dosing interval. However, patients with severe HA who are treated with extended half-life FVIII remain dependent on multiple infusions to maintain critical levels of FVIII activity. There is therefore a strong unmet need for a fully preventive treatment of HA to give patients a FVIII level compatible with a normal and hemorrhage-free life.</p> <p>Gene therapy offers the potential of disease-modifying therapy by continuous endogenous production of active FVIII following a single intravenous infusion of a vector encoding the appropriate gene sequence for long-term episomal expression. Hemophilia A is well-suited for a gene replacement approach because clinical manifestations are attributable to the lack of a single gene product (FVIII) that circulates in minute amounts (200 ng/ml) in the plasma. Tightly regulated control of gene expression is not essential, and even modest increases in the level of FVIII (any increase of the plasma level by 2 ng/ml induces an increase in activity of 1%) can ameliorate the severe form of hemophilia A. Thus, relatively small changes in endogenous FVIII activity can result in clinically relevant improvements in disease phenotype. Finally, the circulating FVIII response to gene transduction can be assessed using validated quantitative rather than qualitative endpoints that are easily assayed using established laboratory techniques.</p> <p>Several different gene transfer strategies for FVIII replacement have been evaluated, but adeno-associated viral (AAV) vectors show the greatest promise. They have an excellent and well-defined safety profile, and can direct long-term transgene expression with tropism and promoter specificity for specific tissues, such as the liver (for serotypes 2, 5 and 8 among others). Indeed, an ongoing gene therapy clinical trial for a related disorder, hemophilia B, has established that stable (median follow-up of 3.2 years) expression of human factor IX (hFIX) at levels that are sufficient for conversion of their bleeding phenotype from severe to moderate or mild is achievable following a single peripheral vein infusion of AAV8-hFIX vector. Several participants in this trial have been able to discontinue factor prophylaxis without suffering spontaneous hemorrhages, even when they undertook activities that previously resulted in bleeding. Thus, gene therapy treatment has resulted in a substantial improvement in their quality of life (<a href="#">Nathwani, 2014, N Engl J Med</a>). BMN 270 is an AAV5-based gene therapy vector that expresses the SQ form of hFVIII under the control of a hybrid human liver-specific promoter (<a href="#">Figure 1</a>).</p> |  |   |

|   |         |        |
|---|---------|--------|
|  | 270-301 | Page 4 |
|---|---------|--------|

|  |  |  |
|--|--|--|
| <p><b>NAME OF COMPANY</b><br/>                 BioMarin Pharmaceutical Inc.<br/>                 105 Digital Drive<br/>                 Novato, CA 94949</p> <p><b>NAME OF FINISHED PRODUCT:</b><br/>                 BMN 270</p> <p><b>NAME OF ACTIVE INGREDIENT:</b><br/>                 AAV5-hFVIII-SQ</p> | <p><b>SUMMARY TABLE</b><br/>                 Referring to Part of the Dossier:</p> <p>Volume:</p> <p>Page:</p> <p>Reference:</p> | <p><b>FOR NATIONAL AUTHORITY USE ONLY:</b></p> |
|--|--|--|

**Figure 1. hFVIII-SQ Vector Genome Schematic**

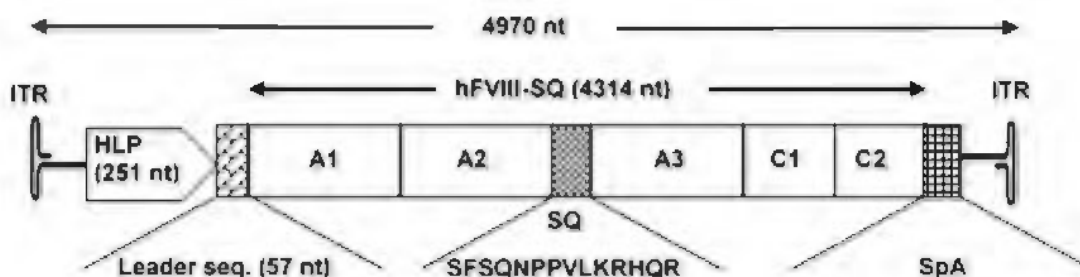

Legend –Note that schematic is not to scale; nt = nucleotides

BMN 270 will be delivered by a single intravenous dose and is designed to achieve stable, potentially life-long expression of active hFVIII in the plasma, synthesized from vector-transduced liver tissue.

BMN 270 is currently being evaluated in clinical study 270-201, an ongoing first-in-human, phase 1/2 dose escalation study in subjects with severe HA designed to assess the safety and efficacy of BMN 270 at various dose levels (6E12 vg/kg, 2E13 vg/kg, 4E13 vg/kg, 6E13 vg/kg). Specifically, 270-201 explores the relationship of vector dose to the augmentation of residual FVIII activity and whether these levels are sufficient to alter the clinical phenotype. Preliminary results from 270-201 have demonstrated that following gene transfer, FVIII activity above 5% (5 IU/dL) and, in many cases, within the normal range for FVIII, is achievable at doses of 4-6E13 vg/kg with an acceptable safety profile (Pasi, 2016, Haemophilia).

The current study is a Phase 3, single-arm, open-label study designed to assess whether, in an expanded sample, BMN 270 can safely alter the clinical phenotype of hemophilia A patients with residual FVIII activity  $\leq 1$  IU/dL, with an altered phenotype defined as achieving FVIII activity of  $> 5\%$  (5 IU/ dL).

**OBJECTIVES:**

The primary efficacy objectives of the study are to:

- Assess the efficacy of BMN 270 defined as median FVIII activity during Weeks 48-52 following intravenous infusion of BMN 270

The secondary efficacy objectives of the study are to:

- Assess the impact of BMN 270 on usage of exogenous FVIII replacement therapy from Week 5 to Week 52

|   |                |               |
|---|----------------|---------------|
|  | <p>270-301</p> | <p>Page 5</p> |
|---|----------------|---------------|

|   |   |  |
|---|---|--|
| <p><b>NAME OF COMPANY</b><br/>BioMarin Pharmaceutical Inc.<br/>105 Digital Drive<br/>Novato, CA 94949</p> <p><b>NAME OF FINISHED PRODUCT:</b><br/>BMN 270</p> <p><b>NAME OF ACTIVE INGREDIENT:</b><br/>AAV5-hFVIII-SQ</p> | <p><b>SUMMARY TABLE</b><br/>Referring to Part of the Dossier:</p> <p>Volume:</p> <p>Page:</p> <p>Reference:</p> | <p><b>FOR NATIONAL AUTHORITY USE ONLY:</b></p> |
|---|---|--|

|   |
|---|
| <ul style="list-style-type: none"> <li>Assess the impact of BMN 270 on the number of bleeding episodes requiring exogenous FVIII replacement therapy from Week 5 to Week 52</li> </ul> <p>The tertiary efficacy objectives of the study are to:</p> <ul style="list-style-type: none"> <li>Assess the impact of BMN 270 on patient-reported outcomes (PROs) at Week 52 of the study compared to baseline</li> </ul> <p>The safety objectives of the study are to:</p> <ul style="list-style-type: none"> <li>Evaluate the safety of BMN 270 during the first 52 weeks following intravenous infusion</li> <li>Assess the long-term safety of BMN 270</li> </ul> |
|---|

|   |
|---|
| <p><b>STUDY DESIGN AND PLAN:</b></p> <p>This is a Phase 3, single-arm, open-label study in hemophilia A patients with residual FVIII levels <math>\leq 1</math> IU/dL treated continuously with prophylactic exogenous FVIII for the year prior to enrollment. Subjects will be enrolled at approximately 30 sites worldwide. Subjects must have high-quality, well-documented historical data available concerning previous bleeding episodes and exogenous FVIII usage over the previous 12 months in order to be eligible to enroll in the study.</p> <p>Approximately 40 subjects will receive a 6E13 vg/kg dose of BMN 270 as an intravenous infusion. The Data Monitoring Committee (DMC) will review available safety and efficacy (eg, FVIII activity) data during the study on an ongoing basis and may determine, based on emerging data and the risk/benefit profile, that further enrollment at 6E13 vg/kg should be discontinued in favor of a different dose of BMN 270. If the DMC recommends a dosing modification, then additional subjects may be enrolled, up to a total of approximately 40 subjects, at the new BMN 270 dose level (regardless of the number of subjects previously enrolled at 6E13 vg/kg).</p> <p>An interim analysis will be performed after all subjects have been followed for 26 weeks post-BMN 270 infusion.</p> <p>The final analysis for the study will be performed after all subjects have been followed for 52 weeks post-BMN 270 infusion. After the final analysis, safety and efficacy will then continue to be assessed long-term in all subjects for a total of approximately 5 years.</p> <p>To avoid breakthrough bleeding, subjects will only discontinue exogenous prophylactic FVIII replacement therapy after FVIII activity has reached at least 5 IU/dL or 4 weeks following infusion of BMN 270, whichever is earlier. Four weeks represents the time by which endogenous production of FVIII following gene transfer is expected to be efficacious.</p> <p>Throughout the study, subjects with FVIII activity below 5 IU/dL may be monitored more frequently at the discretion of the Medical Monitor and the Investigator.</p> |
|---|



|                 |         |        |
|-----------------|---------|--------|
| <b>B:OMARIN</b> | 270-301 | Page 6 |
|-----------------|---------|--------|

|  |   |   |
|--|---|---|
| <b>NAME OF COMPANY</b><br>BioMarin Pharmaceutical Inc.<br>105 Digital Drive<br>Novato, CA 94949<br><br><b>NAME OF FINISHED PRODUCT:</b><br>BMN 270<br><br><b>NAME OF ACTIVE INGREDIENT:</b><br>AAV5-hFVIII-SQ  | <b>SUMMARY TABLE</b><br>Referring to Part of the Dossier:<br><br>Volume:<br><br>Page:<br><br>Reference: | <b>FOR NATIONAL AUTHORITY USE ONLY:</b> |
| <p>There will be an ongoing review of individual subject safety and efficacy data by the Medical Monitor and the DMC. FVIII activity by a validated assay will be used to evaluate efficacy over the course of the study. Therapeutic oral corticosteroids may be initiated when a subject's ALT values are elevated or based on review of FVIII activity and liver enzyme data, and subsequent dosage adjustments made, after consultation between the Investigator and the Medical Monitor. Any safety signal may trigger a review of the data and possible additional immunogenicity studies or other diagnostics deemed necessary that include an assessment of cellular immune responses using collected peripheral blood mononuclear cells (PBMCs).</p>  |   |   |
| <b>NUMBER OF SUBJECTS PLANNED:</b><br>Approximately 40 subjects may enroll into the study.   |   |   |
| <b>DIAGNOSIS AND ALL CRITERIA FOR INCLUSION AND EXCLUSION:</b><br>Participants are eligible to be included in the study only if all of the following criteria apply: <ol style="list-style-type: none"> <li>1. Males <math>\geq</math> 18 years of age with hemophilia A and residual FVIII levels <math>\leq</math> 1 IU/dL as evidenced by medical history, at the time of signing the informed consent.</li> <li>2. Must have been on prophylactic FVIII replacement therapy for at least 12 months prior to study entry. High-quality, well-documented historical data concerning bleeding episodes and FVIII usage over the previous 12 months must be available.</li> <li>3. Treated/exposed to FVIII concentrates or cryoprecipitate for a minimum of 150 exposure days (EDs).</li> <li>4. Willing and able to provide written, signed informed consent after the nature of the study has been explained and prior to any study-related procedures.</li> <li>5. No history of FVIII inhibitor, and results from a Bethesda assay with Nijmegen modification of less than 0.6 Bethesda Units (BU) on 2 consecutive occasions (the most recent one of which should be tested at the central laboratory) at least one week apart within the past 12 months</li> <li>6. Sexually active participants must agree to use an acceptable method of double barrier contraception for at least 6 months post-infusion, which may include hormonal contraception for a female partner. After 6 months, subjects may stop contraception use only if they have had 3 consecutive semen samples with no detectable viral vector DNA.</li> <li>7. Willing to abstain from alcohol consumption for at least the first 52 weeks following BMN 270 infusion.</li> </ol> |   |   |

|                 |         |        |
|-----------------|---------|--------|
| <b>B:OMARIN</b> | 270-301 | Page 7 |
|-----------------|---------|--------|

| <b>NAME OF COMPANY</b><br>BioMarin Pharmaceutical Inc.<br>105 Digital Drive<br>Novato, CA 94949   | <b>SUMMARY TABLE</b><br>Referring to Part of the<br>Dossier:<br><br>Volume:<br><br>Page:<br><br>Reference: | <b>FOR NATIONAL<br/>AUTHORITY USE<br/>ONLY:</b> |
|---|--|---|
| <p>8. HIV positive patients may be enrolled, only if the patient has a CD4 count <math>&gt; 200/\text{mm}^3</math> and an undetectable viral load.</p> <p>Participants are excluded from the study if any of the following criteria apply:</p> <ol style="list-style-type: none"> <li>1. Detectable pre-existing antibodies to the AAV5 capsid.</li> <li>2. Any evidence of active infection or any immunosuppressive disorder, except for HIV infection as described in the inclusion criterion above.</li> <li>3. Significant liver dysfunction with any of the following abnormal laboratory results: <ul style="list-style-type: none"> <li>• ALT (alanine transaminase) or AST <math>&gt;2X</math> ULN;</li> <li>• Total bilirubin <math>&gt;2X</math> ULN;</li> <li>• Alkaline phosphatase <math>&gt;2X</math> ULN; or</li> <li>• INR (international normalized ratio) <math>\geq 1.4</math>.</li> </ul> <p>Subjects whose liver laboratory assessments fall outside of these ranges may undergo repeat testing and, if eligibility criteria are met on retest, may be enrolled after confirmation by the Medical Monitor. In addition, subjects with abnormal laboratory results related to confirmed benign liver conditions (eg, Gilbert's syndrome) are considered eligible for the study notwithstanding their abnormal laboratory results and may be enrolled after discussion with the Medical Monitor.</p> </li> <li>4. Prior liver biopsy showing significant fibrosis of 3 or 4 as rated on a scale of 0-4 on the Batts-Ludwig (<a href="#">Batts 1995</a>) or METAVIR (<a href="#">Bedossa 1996</a>) scoring systems, or an equivalent grade of fibrosis if an alternative scale is used.</li> <li>5. Evidence of any bleeding disorder not related to hemophilia A.</li> <li>6. Platelet count of <math>&lt; 100 \times 10^9/\text{L}</math>.</li> <li>7. Creatinine <math>\geq 1.5</math> mg/dL.</li> <li>8. Liver cirrhosis of any etiology as assessed by liver ultrasound.</li> <li>9. Chronic or active hepatitis B as evidenced by positive serology testing and confirmatory HBV DNA testing. Refer to the Centers for Disease Control (CDC) table for the interpretation of serological test results in the Laboratory Manual.</li> <li>10. Active Hepatitis C as evidenced by detectable HCV RNA or currently on antiviral therapy.</li> </ol> |  |   |

|                 |         |        |
|-----------------|---------|--------|
| <b>B:OMARIN</b> | 270-301 | Page 8 |
|-----------------|---------|--------|

| <b>NAME OF COMPANY</b><br>BioMarin Pharmaceutical Inc.<br>105 Digital Drive<br>Novato, CA 94949   | <b>SUMMARY TABLE</b><br>Referring to Part of the<br>Dossier:<br><br>Volume:<br><br>Page:<br><br>Reference: | <b>FOR NATIONAL<br/>AUTHORITY USE<br/>ONLY:</b> |
|---|--|---|
| <p>11. Active malignancy, except non-melanoma skin cancer.</p> <p>12. History of hepatic malignancy.</p> <p>13. History of arterial or venous thromboembolic events (eg, deep vein thrombosis, non-hemorrhagic stroke, pulmonary embolism, myocardial infarction, arterial embolus), with the exception of catheter-associated thrombosis for which anti-thrombotic treatment is not currently ongoing.</p> <p>14. Known inherited or acquired thrombophilia, including conditions associated with increased thromboembolic risk, such as atrial fibrillation.</p> <p>15. Treatment with any Investigational Product within 30 days prior to the screening period. For subjects who have received a prior investigational product, all ongoing adverse events (AEs) experienced while receiving that investigational product must have resolved prior to screening for this study.</p> <p>16. Any condition that, in the opinion of the Investigator or Sponsor would prevent the patient from fully complying with the requirements of the study (including possible corticosteroid treatment outlined in the protocol) and/or would impact or interfere with evaluation and interpretation of subject safety or efficacy result.</p> <p>17. Prior treatment with any vector or gene transfer agent.</p> <p>18. Major surgery planned in the 52-week period following the infusion with BMN 270.</p> <p>Use of systemic immunosuppressive agents, not including corticosteroids, or live vaccines within 30 days before the BMN 270 infusion.</p> <p>Concurrent enrollment in another clinical study, unless it is an observational (non-interventional) clinical study that does not interfere with the requirements of the current protocol or have the potential to impact the evaluation of efficacy and safety of BMN 270 and with prior consultation with the Medical Monitor.</p> <p>Known allergy or hypersensitivity to BMN 270 investigational product formulation.</p> <p>Unwilling to receive blood or blood products for treatment of an adverse event and/or a bleeding episode.</p> |  |   |

|                 |         |        |
|-----------------|---------|--------|
| <b>B:OMARIN</b> | 270-301 | Page 9 |
|-----------------|---------|--------|

|  |   |   |
|--|---|---|
| <b>NAME OF COMPANY</b><br>BioMarin Pharmaceutical Inc.<br>105 Digital Drive<br>Novato, CA 94949<br><br><b>NAME OF FINISHED PRODUCT:</b><br>BMN 270<br><br><b>NAME OF ACTIVE INGREDIENT:</b><br>AAV5-hFVIII-SQ  | <b>SUMMARY TABLE</b><br>Referring to Part of the Dossier:<br><br>Volume:<br><br>Page:<br><br>Reference: | <b>FOR NATIONAL AUTHORITY USE ONLY:</b> |
| <b>INVESTIGATIONAL PRODUCT(S), DOSE, ROUTE AND REGIMEN:</b><br>Each subject will receive a single intravenous infusion of BMN 270 at 6E13 vg/kg. The volume of infusion will depend on the subject's weight.   |   |   |
| <b>REFERENCE THERAPY(IES), DOSE, ROUTE AND REGIMEN:</b><br>No reference therapy will be evaluated in this study.   |   |   |
| <b>DURATION OF TREATMENT:</b><br>BMN 270 is given as a single dose by intravenous infusion.  |   |   |
| <b>CRITERIA FOR EVALUATION:</b><br><u>Efficacy:</u><br>Primary efficacy endpoints: <ul style="list-style-type: none"> <li>• Change of the median hFVIII activity during Weeks 48-52 post-BMN 270 infusion from baseline using a validated assay. Values for hFVIII activity will be excluded if obtained within 72 hours since the last infusion of exogenous FVIII protein concentrates (or 5x the known half-life of the FVIII concentrates administered).</li> </ul> Secondary efficacy endpoints: <ul style="list-style-type: none"> <li>• Change in the annualized utilization (IU/kg) of exogenous FVIII replacement therapy during Week 5 to Week 52 post-BMN 270 infusion from the baseline utilization of exogenous FVIII replacement therapy calculated using subjects' historical medical records during the year prior to enrollment.</li> <li>• Change in the annualized number of bleeding episodes requiring exogenous FVIII replacement treatment during Week 5 to Week 52 of the study post-BMN 270 infusion from the baseline ABR calculated using subjects' historical medical records during the year prior to enrollment.</li> </ul> Tertiary efficacy endpoints: <ul style="list-style-type: none"> <li>• Change from baseline in the total score of HAEMO-QoL-A at Week 52 of the study post-BMN 270 infusion.</li> <li>• Change from baseline in the EQ-5D-5L score at Week 52 of the study post-BMN 270 infusion.</li> <li>• Change from baseline in the Haemophilia Activities List (HAL) score at Week 52 of the study post-BMN 270 infusion.</li> <li>• Change from baseline in the Work Productivity and Activity Impairment plus Classroom Impairment Questions: Hemophilia Specific (WPAI+CIQ:HS) score at Week 52 of the study post-BMN 270 infusion.</li> </ul> |   |   |

|                 |         |         |
|-----------------|---------|---------|
| <b>B:OMARIN</b> | 270-301 | Page 10 |
|-----------------|---------|---------|

| <b>NAME OF COMPANY</b><br>BioMarin Pharmaceutical Inc.<br>105 Digital Drive<br>Novato, CA 94949   | <b>SUMMARY TABLE</b><br>Referring to Part of the<br>Dossier:<br><br>Volume:<br><br>Page:<br><br>Reference: | <b>FOR NATIONAL<br/>AUTHORITY USE<br/>ONLY:</b> |
|---|--|---|
| <p><u>Safety:</u></p> <p>The following safety outcome measurements will be assessed:</p> <ul style="list-style-type: none"> <li>• Incidence of adverse events (AEs) and serious AEs (SAEs)</li> <li>• Change in clinical laboratory tests (serum chemistry and hematology)</li> <li>• Change in vital signs</li> <li>• Change in physical examination</li> <li>• Vector shedding (blood, urine, semen, feces, saliva)</li> <li>• Liver function tests (LFTs, including ALT, AST, GGT, LDH, bilirubin, alkaline phosphatase)</li> <li>• Immune response to FVIII transgene product and AAV5 capsid proteins</li> </ul> <p>Each subject will have comprehensive surveillance monitoring of LFTs (once per week for Weeks 1-36, and then once every 2 weeks from Weeks 37-52) during Year 1. LFTs will be monitored every three months for up to 5 years post-dose in the safety extension; the frequency and duration of LFT testing may be changed based on discussion between the Medical Monitor and the Investigator, review of subject data, and/or by independent DMC feedback.</p> <p>There will be a detailed assessment of cellular and humoral responses to AAV5 capsid and FVIII protein.</p> <p><u>Pharmacodynamics:</u></p> <p>The FVIII protein concentration and activity level as measured by a validated immunoassay and a validated FVIII activity assay, respectively, will be used for plasma profiles; FVIII protein and activity will be used to determine PD parameters.</p> |  |   |

|                 |         |         |
|-----------------|---------|---------|
| <b>B:OMARIN</b> | 270-301 | Page 11 |
|-----------------|---------|---------|

|   |   |   |
|---|---|---|
| <b>NAME OF COMPANY</b><br>BioMarin Pharmaceutical Inc.<br>105 Digital Drive<br>Novato, CA 94949<br><br><b>NAME OF FINISHED PRODUCT:</b><br>BMN 270<br><br><b>NAME OF ACTIVE INGREDIENT:</b><br>AAV5-hFVIII-SQ   | <b>SUMMARY TABLE</b><br>Referring to Part of the Dossier:<br><br>Volume:<br><br>Page:<br><br>Reference: | <b>FOR NATIONAL AUTHORITY USE ONLY:</b> |
| <b>STATISTICAL METHODS:</b><br><u>Sample Size</u><br><p>Forty (40) subjects may be dosed in the study. Assuming a rate of subject discontinuation of up to 15%, a sample size of 40 will provide at least 90% power to demonstrate that the change in median hFVIII activity at Weeks 48-52 from baseline is statistically significant, assuming an effect size of 0.6, using a one-sample t-test with an 2-sided significance level of 0.049. The sample size of 40 will also have at least 90% power for hypothesis testing of each of the secondary endpoints.</p> <u>Analysis Population</u><br><p>The efficacy analysis set will be comprised of all subjects who have received BMN 270 infusion. The safety population will consist of all subjects who receive BMN 270 infusion during the study.</p> <u>Analysis</u><br><p>For the primary efficacy endpoint at Week 52 (ie, the change in the median hFVIII activity during Weeks 48-52 post-BMN 270 infusion from baseline), a one-sample t-test will be used to test the null hypothesis that the change is 0 or less against the alternative hypothesis that the change is greater than 0.</p> <p>For the first secondary efficacy endpoint at Week 52 (ie, the change in the annualized utilization (IU/kg) of exogenous FVIII replacement therapy during Weeks 5-52 post-BMN 270 infusion from baseline), a one-sample t-test will be performed to test the null hypothesis that the change is 0 or greater against the alternative hypothesis that the change is less than 0.</p> <p>For the second secondary efficacy endpoint at Week 52 (ie, the change in the annualized number of bleeding episodes requiring exogenous FVIII replacement treatment during Weeks 5-52 post-BMN 270 infusion from baseline), a one-sample t-test will be performed to test for non-inferiority of BMN 270 against FVIII prophylaxis using a margin of 3.5. If non-inferiority is demonstrated, the test for superiority of BMN 270 against FVIII prophylaxis will be performed.</p> <p>The primary endpoint and secondary endpoints will be tested sequentially according to the order described above.</p> <p>An interim analysis is planned when all 40 treated subjects have completed the Week 26 visit. The primary efficacy endpoint for the interim analysis is change in the median hFVIII activity during Weeks 22-26 post-BMN 270 infusion from baseline. The secondary efficacy endpoints for the interim analysis will be defined as follows:</p> <ul style="list-style-type: none"> <li>• Change in the annualized utilization (IU/kg) of exogenous FVIII replacement therapy during Weeks 5-26 post-BMN 270 infusion from baseline.</li> </ul> |   |   |



|                 |         |         |
|-----------------|---------|---------|
| <b>B:OMARIN</b> | 270-301 | Page 12 |
|-----------------|---------|---------|

| <b>NAME OF COMPANY</b><br>BioMarin Pharmaceutical Inc.<br>105 Digital Drive<br>Novato, CA 94949   | <b>SUMMARY TABLE</b><br>Referring to Part of the<br>Dossier:<br><br>Volume:<br><br>Page:<br><br>Reference: | <b>FOR NATIONAL<br/>AUTHORITY USE<br/>ONLY:</b> |
|---|--|---|
| <p><b>NAME OF FINISHED PRODUCT:</b><br/>BMN 270</p> <p><b>NAME OF ACTIVE INGREDIENT:</b><br/>AAV5-hFVIII-SQ</p> <ul style="list-style-type: none"> <li>Change in the annualized number of bleeding episodes requiring exogenous FVIII replacement treatment during Weeks 5-26 post-BMN 270 infusion from baseline (tested first for non-inferiority using a margin of 3.5 and then for superiority).</li> </ul> <p>The primary and secondary efficacy hypotheses at the interim analysis will be tested sequentially according to the order described above.</p> <p>The Bonferroni procedure will be used to adjust for multiplicity using <math>\alpha=0.001</math> at the interim analysis and <math>\alpha=0.049</math> at the final analysis.</p> <p>However, regardless of the interim analysis results, the study will continue, and the final analysis will be performed at Week 52.</p> <p>The tertiary endpoints will be analyzed at the interim (Week 26) and final (Week 52) analyses, irrespective of the aforementioned hierarchical testing.</p> <p>Analysis of safety endpoints will be primarily descriptive. The incidence of AEs will be summarized by system organ class, preferred term, relationship to study drug, seriousness, and severity. Clinical laboratory test values, vital signs, vector shedding and immune response parameters will be summarized descriptively by visit.</p> |  |   |

|                 |         |         |
|-----------------|---------|---------|
| <b>B:OMARIN</b> | 270-301 | Page 13 |
|-----------------|---------|---------|

### 3 TABLE OF CONTENTS

|       |  |    |
|-------|--|----|
| 2     | SYNOPSIS.....  | 2  |
| 3     | TABLE OF CONTENTS.....   | 13 |
| 4     | LIST OF ABBREVIATIONS AND DEFINITIONS OF TERMS.....                | 18 |
| 5     | ETHICS.....  | 21 |
| 5.1   | Institutional Review Board or Independent Ethics Committee .....   | 21 |
| 5.2   | Ethical Conduct of Study .....                                     | 21 |
| 5.3   | Subject Information and Informed Consent.....                      | 22 |
| 6     | INVESTIGATORS AND STUDY ADMINISTRATIVE STRUCTURE .....             | 23 |
| 7     | INTRODUCTION .....   | 24 |
| 7.1   | Nonclinical Studies .....  | 24 |
| 7.2   | Previous Clinical Studies .....                                    | 25 |
| 7.3   | Study Rationale .....  | 25 |
| 7.4   | Summary of Overall Risks and Benefits.....                         | 28 |
| 8     | STUDY OBJECTIVES.....  | 29 |
| 9     | INVESTIGATIONAL PLAN.....  | 30 |
| 9.1   | Overall Study Design and Plan .....                                | 30 |
| 9.2   | Discussion of Study Design, Including Choice of Control Group..... | 45 |
| 9.3   | Selection of Study Population.....                                 | 45 |
| 9.3.1 | Inclusion Criteria.....  | 45 |
| 9.3.2 | Exclusion Criteria.....  | 46 |
| 9.3.3 | Removal of Subjects from Treatment or Assessment .....             | 48 |
| 9.3.4 | Subject Identification and Replacement of Subjects.....            | 49 |
| 9.3.5 | Duration of Subject Participation.....                             | 50 |
| 9.4   | Treatments.....  | 50 |
| 9.4.1 | Treatments Administered .....                                      | 50 |
| 9.4.2 | Identity of Investigational Product.....                           | 50 |
| 9.4.3 | Storage.....   | 50 |
| 9.4.4 | Directions for Administration .....                                | 50 |
| 9.4.5 | Method of Assigning Subjects to Treatment Groups.....              | 51 |

|          |         |         |
|----------|---------|---------|
| B:OMARIN | 270-301 | Page 14 |
|----------|---------|---------|

|        |   |    |
|--------|---|----|
| 9.4.6  | Selection of Dose Used in the Study .....   | 51 |
| 9.4.7  | Blinding.....   | 52 |
| 9.4.8  | Prior and Concomitant Medications.....  | 52 |
| 9.4.9  | Treatment Compliance .....  | 55 |
| 9.5    | Investigational Product Accountability.....   | 55 |
| 9.5.1  | Return and Disposition of Clinical Supplies .....   | 55 |
| 9.6    | Dietary or Other Protocol Restrictions.....   | 56 |
| 9.7    | Safety and Efficacy Variables.....  | 56 |
| 9.7.1  | Safety and Efficacy Measurements Assessed .....   | 56 |
| 9.7.2  | Primary Efficacy Variables .....  | 56 |
| 9.7.3  | Secondary Efficacy Variables .....  | 57 |
| 9.7.4  | Tertiary Efficacy Variables .....   | 57 |
| 9.7.5  | Immunogenicity.....   | 58 |
| 9.7.6  | Pharmacodynamics.....   | 59 |
| 9.7.7  | Exploratory Assessments .....   | 59 |
| 9.7.8  | Safety Variables .....  | 59 |
| 10     | REPORTING ADVERSE EVENTS .....  | 65 |
| 10.1   | Safety Parameters and Definitions.....  | 65 |
| 10.1.1 | Adverse Events.....   | 65 |
| 10.2   | Serious Adverse Events .....  | 66 |
| 10.2.1 | Events of Special Interest (EOSI) .....   | 66 |
| 10.3   | Methods and Timing for Capturing and Assessing Safety Parameters.....                     | 67 |
| 10.3.1 | Adverse Event Reporting Period.....   | 67 |
| 10.3.2 | Eliciting Adverse Events .....  | 67 |
| 10.3.3 | Assessment of Seriousness, Severity, and Causality.....                                   | 67 |
| 10.4   | Procedures for Recording Adverse Events .....   | 70 |
| 10.4.1 | Recording Adverse Events on a eCRF .....  | 70 |
| 10.5   | Reporting Requirements .....  | 73 |
| 10.5.1 | Expedited Reporting Requirements.....   | 73 |
| 10.5.2 | Institutional Review Board or Independent Ethics Committee<br>Reporting Requirements..... | 74 |

|          |         |         |
|----------|---------|---------|
| B:OMARIN | 270-301 | Page 15 |
|----------|---------|---------|

|         |  |    |
|---------|--|----|
| 10.6    | Follow-up of Subjects after Adverse Events.....                              | 74 |
| 10.7    | Post-Study Adverse Events.....   | 74 |
| 10.8    | Urgent Safety Measures.....  | 75 |
| 10.9    | BioMarin Pharmacovigilance Contact Information.....                          | 75 |
| 11      | APPROPRIATENESS OF MEASUREMENTS.....   | 77 |
| 12      | STUDY PROCEDURES.....  | 78 |
| 12.1    | Prestudy.....  | 78 |
| 12.2    | Screening Visit.....   | 78 |
| 12.2.1  | “Smart Rescreening” Visit.....   | 79 |
| 12.3    | Baseline Visit.....  | 80 |
| 12.4    | Treatment Visit/BMN 270 Infusion Visit (Day 1).....                          | 81 |
| 12.5    | BMN 270 Infusion Follow-Up Visits – Weeks 1-26.....                          | 81 |
| 12.5.1  | Once per week (Weeks 1 through 26).....                                      | 81 |
| 12.5.2  | Week 1 – Day 4.....  | 82 |
| 12.5.3  | Week 1 – Day 8.....  | 82 |
| 12.5.4  | Every 2 Weeks (Week 2, 4, 6, 8, 10, 12, 14, 16, 18, 20, 22, 24, and 26)..... | 82 |
| 12.5.5  | Weeks 2, 4, 10, 16, 22, and 26.....  | 82 |
| 12.5.6  | Weeks 2, 3, 4, 6, 8, 12, 16, 20, 24, and 26.....                             | 82 |
| 12.5.7  | Weeks 4, 12, and 26.....   | 82 |
| 12.5.8  | Every 4 Weeks (Weeks 4, 8, 12, 16, 20, and 24) Plus Week 26.....             | 83 |
| 12.5.9  | Every 8 Weeks (Weeks 8, 16, and 24).....                                     | 83 |
| 12.5.10 | Weeks 6, 13, 16, 20, 24, and 26.....   | 83 |
| 12.5.11 | Weeks 12 and 26.....   | 83 |
| 12.5.12 | Week 13 and 26.....  | 83 |
| 12.5.13 | Week 16.....   | 83 |
| 12.5.14 | Week 20, 24, and 26.....   | 84 |
| 12.6    | Post-Infusion Follow-Up – Weeks 27-52.....                                   | 84 |
| 12.6.1  | Every Visit.....   | 84 |
| 12.6.2  | Weeks 28, 30, 32, 34, 36, 44, and 52.....                                    | 85 |
| 12.6.3  | Every 4 Weeks (Weeks 28, 32, 36, 40, 44, 48, 52).....                        | 85 |

|          |         |         |
|----------|---------|---------|
| B:OMARIN | 270-301 | Page 16 |
|----------|---------|---------|

|        |  |     |
|--------|--|-----|
| 12.6.4 | Weeks 32, 36, 44, and 52 .....                                       | 85  |
| 12.6.5 | Weeks 32, 36, 40, 44, 48, and 52 .....                               | 85  |
| 12.6.6 | Week 32, 36, and 52.....   | 85  |
| 12.6.7 | Week 36 and 52.....  | 85  |
| 12.6.8 | Week 52.....   | 86  |
| 12.7   | Post-Infusion Follow-Up – Years 2-5 .....                            | 86  |
| 12.7.1 | Every Visit.....   | 86  |
| 12.7.2 | Every 4 Weeks (As Needed) .....                                      | 87  |
| 12.7.3 | Every Other Visit (Every 6 Months) .....                             | 87  |
| 12.8   | Early Termination Visit .....  | 87  |
| 12.9   | End of Study.....  | 89  |
| 13     | DATA QUALITY ASSURANCE.....  | 90  |
| 14     | STATISTICAL METHODS AND DETERMINATION OF SAMPLE SIZE.....            | 91  |
| 14.1   | Statistical and Analytical Plans.....                                | 91  |
| 14.1.1 | Interim Analyses.....  | 91  |
| 14.1.2 | Procedures for Accounting for Missing, Unused and Spurious Data..... | 91  |
| 14.2   | Primary and Secondary Efficacy Endpoints .....                       | 92  |
| 14.3   | Immunogenicity .....   | 92  |
| 14.4   | Pharmacodynamic Analyses .....                                       | 93  |
| 14.5   | Safety Analysis .....  | 93  |
| 14.6   | Determination of Sample Size .....                                   | 93  |
| 14.7   | Analysis Populations.....  | 94  |
| 14.8   | Changes in the Conduct of the Study or Planned Analyses.....         | 94  |
| 15     | DATA MONITORING COMMITTEE.....                                       | 95  |
| 16     | COSTS, COMPENSATION, AND SUBJECT INJURY.....                         | 96  |
| 17     | CASE REPORT FORMS AND SOURCE DOCUMENTS .....                         | 97  |
| 18     | STUDY MONITORING AND AUDITING .....                                  | 99  |
| 19     | RETENTION OF RECORDS .....   | 100 |
| 20     | USE OF INFORMATION AND PUBLICATION .....                             | 101 |
| 21     | REFERENCES .....   | 102 |

|                 |         |         |
|-----------------|---------|---------|
| <b>B:OMARIN</b> | 270-301 | Page 17 |
|-----------------|---------|---------|

|      |   |     |
|------|---|-----|
| 22   | INVESTIGATOR RESPONSIBILITIES .....                     | 106 |
| 22.1 | Conduct of Study and Protection of Human Patients ..... | 106 |
| 23   | SIGNATURE PAGE .....                                    | 107 |

## LIST OF TABLES

|                   |  |    |
|-------------------|--|----|
| Table 9.1.1:      | Schedule of Events – Screening and Infusion .....  | 32 |
| Table 9.1.2:      | Schedule of Events – Post-Infusion Follow-Up (Week 1-16).....  | 35 |
| Table 9.1.3:      | Schedule of Events – Post-Infusion Follow-Up (Week 17-32).....   | 38 |
| Table 9.1.4:      | Schedule of Events – Post-Infusion Follow-Up (Week 33 – Year 5).....                                     | 41 |
| Table 9.1.5:      | Schedule of Events – Therapeutic Corticosteroids for LFT Elevations or<br>Decreased FVIII Activity ..... | 44 |
| Table 9.4.8.2.1:  | Adjustments to Corticosteroid Regimen.....   | 54 |
| Table 9.7.8.2.1:  | Clinical Laboratory Tests .....  | 60 |
| Table 9.7.8.3.1:  | Liver Function Tests .....   | 61 |
| Table 9.7.8.3.2:  | Evaluation of ALT Elevations.....  | 62 |
| Table 9.7.8.3.3:  | Viral and Autoimmune Hepatitis Testing.....  | 62 |
| Table 10.3.3.2.1: | Adverse Event Grading (Severity) Scale.....  | 68 |
| Table 10.3.3.3.1: | Causality Attribution Guidance .....   | 69 |

## LIST OF FIGURES

|               |   |    |
|---------------|---|----|
| Figure 7.3.1: | hFVIII-SQ Vector Genome Schematic ..... | 27 |
|---------------|---|----|



## 4 LIST OF ABBREVIATIONS AND DEFINITIONS OF TERMS

### Abbreviations

|         |  |
|---------|--|
| AAV     | adeno-associated virus                                     |
| ABR     | annualized bleeding rate                                   |
| ADL     | activities of daily living                                 |
| ADR     | adverse drug reaction                                      |
| AE      | adverse event  |
| ALT     | alanine aminotransferase                                   |
| APTT    | activated partial thromboplastin time                      |
| ART     | anti-retroviral therapy                                    |
| BPV     | BioMarin Pharmacovigilance                                 |
| BU      | Bethesda Unit  |
| CFR     | Code of Federal Regulations                                |
| CRA     | clinical research associate                                |
| CRF     | case report form   |
| CSR     | clinical study report                                      |
| CTCAE   | Common Terminology Criteria for Adverse Events             |
| DMC     | Data Monitoring Committee                                  |
| eCRF    | electronic case report form                                |
| ED      | exposure days  |
| EOSI    | events of special interest                                 |
| ETV     | early termination visit                                    |
| EudraCT | European Union Drug Regulating Authorities Clinical Trials |
| FAS     | Full Analysis Set  |
| FDA     | Food and Drug Administration                               |
| FIH     | first-in-human   |
| FVIII   | coagulation factor VIII                                    |
| GCP     | Good Clinical Practice                                     |
| HA      | Hemophilia A   |
| HAL     | Haemophilia Activities List                                |
| hFIX    | human coagulation factor IX                                |
| hFVIII  | human coagulation factor VIII                              |
| HIPAA   | Health Insurance Portability and Accountability Act        |
| IB      | investigator brochure                                      |
| ICF     | informed consent form                                      |

|             |   |
|-------------|---|
| ICH         | International Conference on Harmonisation of Technical Requirements for Registration of Pharmaceuticals for Human Use |
| ICH E6 [R2] | ICH Harmonised Tripartite Guideline: Guideline for Good Clinical Practice E6  |
| IEC         | independent ethics committee  |
| IND         | Investigational New Drug (application)  |
| INR         | international normalized ratio  |
| IP          | investigational product   |
| IRB         | institutional review board  |
| IV          | intravenous   |
| LFT         | liver function test   |
| MedDRA      | Medical Dictionary for Regulatory Activities  |
| NOAEL       | no-observed-adverse-effect level  |
| PBMC        | peripheral blood mononuclear cells  |
| PD          | pharmacodynamics  |
| PEG         | polyethylene glycol   |
| PK          | Pharmacokinetics  |
| PRO         | patient-reported outcome  |
| rhFVIII     | recombinant human FVIII protein   |
| REB         | research ethics board   |
| SAE         | serious adverse event   |
| SAP         | statistical analysis plan   |
| SDV         | source data verification  |
| TGA         | thrombin generation assay   |
| ULN         | upper limit of normal   |
| vg          | vector genomes  |
| VWF:Ag      | von Willebrand factor Antigen   |
| WPAI+CIQ:HS | Work Productivity and Activity Impairment plus Classroom Impairment Questions: Hemophilia Specific                    |

**B:OMARIN**

270-301

Page 20

**Definition of Terms:****Investigational Product (IP):**

“A pharmaceutical form of an active ingredient or placebo being tested or used as a reference in a clinical trial, including a product with a marketing authorization when used or assembled (formulated or packaged) in a way different from the approved form, or when used for an unapproved indication, or when used to gain further information about an approved use” (from International Conference on Harmonisation of Technical Requirements for Registration of Pharmaceuticals for Human Use ICH Harmonised Tripartite Guideline: Guideline for Good Clinical Practice E6 [ICH E6 (R2)]).

The terms “IP” and “study drug” may be used interchangeably in the protocol.

## 5 ETHICS

BioMarin Pharmaceutical Inc. (hereafter referred to as BioMarin or the Sponsor) conducts its studies according to the highest ethical and scientific standards. The following sections articulate standards to which Investigators will be held accountable, as well as matters of compliance to document adherence to such standards.

### 5.1 Institutional Review Board or Independent Ethics Committee

Investigators are expected to interact with Ethics Committees (ECs) promptly, as required, during the course of the study. This includes, but is not limited to, providing appropriate documentation to support study initiation and maintaining appropriate flow of safety and other information during the course of the study and for study close-out activities. BioMarin (or designee) will assist Investigators with access to timely and accurate information and with assurance of prompt resolution of any queries.

Prior to initiating the study, the Investigator will obtain written confirmation that the institutional review board (IRB) or independent ethics committee (IEC) [for Canadian protocols, Research Ethics Board (REB)] is properly constituted and compliant with International Conference on Harmonisation of Technical Requirements for Registration of Pharmaceuticals for Human Use (ICH) and Good Clinical Practice (GCP) requirements, applicable laws and local regulations. A copy of the confirmation from the IRB/IEC/REB will be provided to BioMarin or its designee. The Investigator will provide the IRB/IEC/REB with all appropriate material, including the protocol, Investigator's Brochure (IB), the Informed Consent Form (ICF) including compensation procedures, and any other written information provided to the subjects, including all ICFs translated for patients who do not speak the local language at the clinical site. The study will not be initiated and Investigational Product (IP) supplies will not be shipped to the site until appropriate documents from the IRB/IEC/REB confirming unconditional approval of the protocol, the ICF and all subject recruitment materials are obtained in writing by the Investigator and copies are received at BioMarin or its designee. The approval document should refer to the study by protocol title and BioMarin protocol number (if possible), identify the documents reviewed, and include the date of the review and approval. BioMarin will ensure that the appropriate reports on the progress of the study are made to the IRB/IEC/REB and BioMarin by the Investigator in accordance with applicable guidance documents and governmental regulations.

### 5.2 Ethical Conduct of Study

It is expected that Investigators understand and comply with the protocol. This includes, but is not limited to: establishing and meeting enrollment commitments, including providing

eligible subjects for study enrollment; adhering to adverse event reporting, diagnostic, or other procedures as specified in the protocol; and assuring appropriate compliance with study treatment administration and accountability.

This study will be conducted in accordance with the following:

- European Clinical Trial Directive 2001/20/EC and Good Clinical Practice Directive 2005/28/EC, for studies conducted within any European country
- US Code of Federal Regulations (CFR) sections that address clinical research studies, and/or other national and local regulations, as applicable
- ICH Harmonised Tripartite Guideline: Guideline for Good Clinical Practice E6 (ICH E6) or E6(R2) (ICH E6R2) if adopted

Specifically, this study is based on adequately performed laboratory and animal experimentation and human Phase 1 study testing. The study will be conducted under a protocol reviewed and approved by an IRB/IEC/REB and will be conducted by scientifically and medically qualified persons. The potential benefits of the study are in proportion to the potential risks. The rights and welfare of the subjects will be respected and the Investigators conducting the study do not find the hazards to outweigh the potential benefits. Each subject will provide written, informed consent before any study-related tests or evaluations are performed.

### **5.3 Subject Information and Informed Consent**

A properly written and executed informed consent form (ICF), in compliance with ICH E6 (Section 4.8), United States Code of Federal Regulations (CFR) 21 CFR §50, European Clinical Trial Directive 2001/20/EC and Good Clinical Practice Directive 2005/28/EC, and other applicable local regulations, will be obtained for each subject prior to entering the subject into the study. The Investigator will prepare the ICF and provide the documents to BioMarin for approval prior to submission to the IRB/IEC/REB. BioMarin and the IRB/IEC/REB must approve the documents before they are implemented. A copy of the approved ICF, and if applicable, a copy of the approved subject information sheet and all ICFs translated to a language other than the native language of the clinical site must also be received by BioMarin or designee prior to any study-specific procedures being performed.

The Investigator will provide copies of the signed ICF to each subject and will maintain the original in the record file of the subject.

## 6 INVESTIGATORS AND STUDY ADMINISTRATIVE STRUCTURE

During administration of informed consent, expectations regarding participation in the study should be made clear to subjects. Patients who are not willing and/or are not able to comply with all aspects of the study should not be encouraged to participate.

Prior to beginning the study, the Investigator at each site must provide to BioMarin or designee a fully executed and signed Statement of Investigator (SOI) form. A US Food and Drug Administration (FDA) Form FDA 1572 serves as an acceptable SOI form. If Form FDA 1572 may not be used in a particular region, the Investigator must provide a fully executed SOI on the form provided by the Sponsor. All Investigators and Sub-Investigators must be listed on Form FDA 1572 or its equivalent SOI. Financial Disclosure Forms must also be completed for all Investigators and Sub-Investigators listed on the Form FDA 1572 or SOI who will be directly involved in the treatment or evaluation of subjects in this study.

The study will be administered by and monitored by employees or representatives of BioMarin. Clinical research associates (CRAs) or trained designees will monitor each site on a periodic basis and perform verification of source documentation for each subject as well as other required review processes. BioMarin's Regulatory Affairs Department (or designee) will be responsible for the timely reporting of serious adverse events (SAEs) to appropriate regulatory authorities as required.

In multicenter studies, a Coordinating Investigator will be identified who will be responsible for study overview. The Coordinating Investigator will read the clinical study report (CSR) and confirm that it accurately describes the conduct and results of the study, to the best of his or her knowledge. The Coordinating Investigator will be chosen on the basis of active participation in the study, ability to interpret data, and willingness to review and sign the report in a specified timeframe. The identity of the Coordinating Investigator and a list of all Investigators participating in the study will be provided in the CSR.

Clinical Laboratory assessments will be performed at a nominated central laboratory. Bioanalytical samples will be sent to the appropriate specialty laboratories for testing. Refer to laboratory manual for more details.



## 7 INTRODUCTION

Hemophilia A (HA) is an X-linked recessive bleeding disorder that affects approximately 1 in 5,000 males (Nathwani, 1992, *Baillieres Clin.Haematol.*). It is caused by mutations in the factor VIII (FVIII) gene that codes for FVIII protein, an essential cofactor in the coagulation pathway. Clinical manifestations of severe FVIII deficiency are frequent unprovoked bleeding episodes in joints and soft tissues causing permanent disability and occasionally death mostly after brain hemorrhage. Treatment in Western countries (Berntorp, 2012, *Haemophilia.*) consists of intravenous injection of plasma-derived or recombinant FVIII protein concentrates at the time of a bleed to control it or prophylactically to prevent bleeding episodes. The short half-life for FVIII (~8-12 hours) necessitates frequent infusions and makes this treatment prohibitively expensive for the majority of the world's hemophilia A patients. These individuals develop debilitating arthropathy and have a substantially increased risk of death from hemorrhage in life (Stonebraker, 2010, *Haemophilia.*). Chemical modification or bioengineering of FVIII may improve half-life to 18-19 hours (Kaufman, 2013, *Blood*). However, these extended half-life FVIII variants do not eliminate the need for lifelong FVIII protein administration (Hay, 2012, *Blood*).

Gene therapy offers the potential of disease-modifying therapy by continuous endogenous production of human FVIII (hFVIII) following a single administration of vector. Hemophilia A is well-suited for this approach because its clinical manifestations are attributable to the lack of a single gene product (FVIII) that circulates in low amounts (100-200 ng/ml) in the plasma. Tightly regulated control of gene expression is not essential, and a modest increase in the level of FVIII (a plasma level of 2 ng/ml protein leads to a 1% expression) can ameliorate the severe phenotype (Srivastava, 2013, *Haemophilia.*); thus, the therapeutic goal for gene therapy is a modest increase in hFVIII. Finally, the consequences of gene transfer can be assessed using simple quantitative rather than qualitative endpoints that can be easily assayed in most clinical laboratories.

BMN 270 contains the cDNA for the B-domain-deleted SQ FVIII with a liver-specific HLP transcription promoter. The expression cassette is inserted between AAV2 ITRs, and this genome is packaged in the AAV5 capsid. A comprehensive review of BMN 270 is contained in the IB supplied by BioMarin. Investigators are to review this document prior to initiating this study.

### 7.1 Nonclinical Studies

The nonclinical program supports a single IV infusion of BMN 270, the planned clinical route of administration, for the treatment of hemophilia A in male patients. This nonclinical

program took into account the guidelines and reflection papers for gene therapy medicinal products under EMA Advanced Therapies as well as FDA guidance. The primary pharmacodynamics (PD), pharmacokinetics (PK), and toxicity of IV BMN 270 were characterized in a series of single dose studies in species that were vector permissive and responsive to the transgene including normal CD-1 mice, a B- and T-cell deficient mouse model of hemophilia A (B6;129S-*Fcγ<sup>2</sup>tm1Kaz*/J x B6.129S6-*Rag2<sup>tm1Fwa</sup>* N12; FVIII KO x Rag2), and normal cynomolgus and rhesus monkeys. Some PD studies evaluated additional PK, immunogenicity and toxicity endpoints.

Results of the nonclinical program to date are detailed in the IB supplied by BioMarin. Investigators are to review this document prior to initiating this study.

## 7.2 Previous Clinical Studies

Study BMN 270-201 is an ongoing Phase 1/2, dose-escalation study to assess the safety, tolerability, and efficacy of BMN 270 in patients with severe hemophilia A (FVIII  $\leq 1$  IU/dL). Subjects received a single BMN 270 infusion and are to be followed for safety and efficacy for up to 5 years. A total of 15 subjects have been enrolled at one of 4 dose levels (6E12, 2E13, 4E13, and 6E13 vg/kg).

A comprehensive review of safety, efficacy, and immunogenicity results from 270-201 as of the latest data cut is contained in the IB supplied by BioMarin. Investigators are to review this document prior to initiating this study.

## 7.3 Study Rationale

Hemophilia A (HA) is an X-linked recessive bleeding disorder that affects approximately 1 in 5,000 males. It is caused by deficiency in the activity of coagulation factor VIII (FVIII), an essential cofactor in the intrinsic coagulation pathway. This disorder can be either inherited, due to a genetic aberrancy or an acquired immunologic process, leading to insufficient quantities of FVIII or a dysfunctional FVIII, but all are characterized by a defective coagulation process. The clinical phenotype of HA patients generally correlates tightly with the level of residual expression. Severe HA is classified as FVIII activity less than 1% of wild type ( $< 1$  IU/dL), moderate disease comprises 1-5% of wild-type activity and the mild form is 5-40% activity. The clinical manifestations of severe HA are frequent spontaneous bleeding episodes, predominantly in joints and soft tissues, with a substantially increased risk of death from hemorrhage when the brain is involved. Subjects with moderate disease can exhibit manifestations similar to those seen in patients with severe HA, resulting in a comparable bleeding phenotype.

Treatment of severe HA presently consists of intravenous injection of plasma derived or recombinant human FVIII protein (rhFVIII) concentrates both as prophylaxis 2-3 times per week, and at the time of a bleed, to prevent or control bleeding episodes, respectively. The half-life for FVIII (12 to 18 hours for most approved products) necessitates frequent infusions, and although a major advance in the treatment of HA, it remains common for severe HA patients to continue to have multiple bleeding events on prophylactic therapy (median ABR of 1-4 with prophylaxis treatment in a recently published retrospective observational study ([Berntorp, 2016, Haemophilia](#)) and between 1-2 in 6 prospective FVIII interventional studies) and on-demand-only therapy (median ABR of 4.5-18 in a recently published retrospective study ([Berntorp, 2016, Haemophilia](#)) and between 20-60 in 6 prospective FVIII interventional studies). The consequence of multiple bleeding events is the development of debilitating multiple-joint arthropathy and substantially increased risk of death. Chemical modification (eg, direct conjugation of polyethylene glycol (PEG) polymers) and bioengineering of FVIII (eg, FVIII-Fc fusion proteins) improve half-life by approximately 50%, and thus, show promise in reduced dosing and maintaining activity levels above 1% trough for a greater proportion of the dosing interval. However, these extended half-life FVIII variants remain dependent on multiple infusions to maintain critical levels of FVIII activity in severe HA patients. There is therefore a strong unmet need for a fully preventive treatment of HA to give patients a FVIII level compatible with a normal and hemorrhage-free life.

Gene therapy offers the potential of disease-modifying therapy by continuous endogenous production of active FVIII following a single intravenous infusion of a vector encoding the appropriate gene sequence for long-term episomal expression. Hemophilia A is well-suited for a gene replacement approach because clinical manifestations are attributable to the lack of a single gene product (FVIII) that circulates in minute amounts (200 ng/ml) in the plasma. Tightly regulated control of gene expression is not essential, and even modest increases in the level of FVIII (any increase of the plasma level by 2 ng/ml induces an increase in activity of 1%) can ameliorate the severe form of the disease. Thus, relatively small changes in endogenous FVIII activity can result in clinically relevant improvements in disease phenotype. Finally, the circulating FVIII response to gene transduction can be assessed using validated quantitative rather than qualitative endpoints that are easily assayed using established laboratory techniques.

Several different gene transfer strategies for FVIII replacement have been evaluated, but adeno-associated viral (AAV) vectors show the greatest promise. They have an excellent and well-defined safety profile, and can direct long term transgene expression with tropism and

|           |         |         |
|-----------|---------|---------|
| B:OMARIN™ | 270-301 | Page 27 |
|-----------|---------|---------|

promoter specificity for specific tissues such as the liver (for serotypes 2, 5 and 8 among others). Indeed, an on-going gene therapy clinical trial for a related disorder, hemophilia B, has established that stable (median follow-up of 3.2 years) expression of human factor IX (hFIX) at levels that are sufficient for conversion of their bleeding phenotype from severe to moderate or mild is achievable following a single peripheral vein infusion of AAV8-hFIX vector. Several participants in this trial have been able to discontinue factor prophylaxis without suffering spontaneous hemorrhages, even when they undertook activities that previously resulted in bleeding. Thus, gene therapy treatment has resulted in a substantial improvement in their quality of life (Nathwani, 2014, *N Engl J Med*).

BMN 270 is an AAV5-based gene therapy vector that expresses the SQ form of hFVIII under the control of a hybrid human liver-specific promoter (Figure 7.3.1).

**Figure 7.3.1: hFVIII-SQ Vector Genome Schematic**

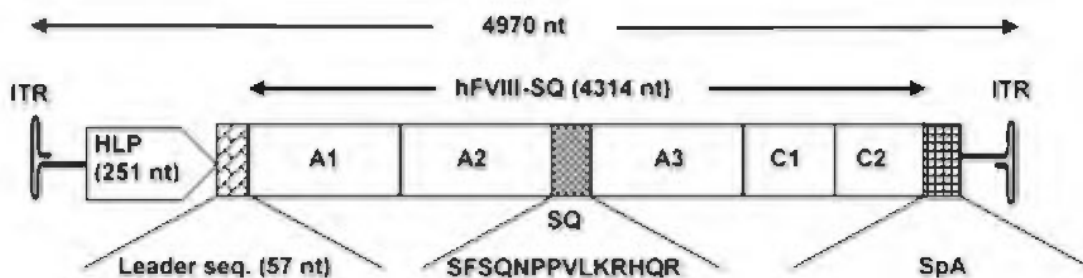

Legend –Note that schematic is not to scale; nt = nucleotides

BMN 270 will be delivered by a single intravenous dose and is designed to achieve stable, potentially life-long expression of active hFVIII in the plasma, synthesized from vector-transduced liver tissue.

BMN 270 is currently being evaluated in clinical study 270-201, an ongoing first-in-human, phase 1/2 dose escalation study in subjects with severe HA designed to assess the safety and efficacy of BMN 270 at various dose levels (6E12 vg/kg, 2E13 vg/kg, 4E13 vg/kg, 6E13 vg/kg). Specifically, 270-201 explores the relationship of vector dose to the augmentation of residual FVIII activity and whether these levels are sufficient to alter the clinical phenotype. Preliminary results from 270-201 have demonstrated that following gene transfer, FVIII activity above 5% (5 IU/dL) and, in many cases, within the normal range for FVIII, is achievable at doses of 4-6E13 vg/kg with an acceptable safety profile (Pasi, 2016, *Haemophilia*).

The current study is a Phase 3, single-arm, open-label study designed to assess whether, in an expanded sample, BMN 270 can safely alter the clinical phenotype of hemophilia A patients

with residual FVIII activity  $\leq 1$  IU/dL, with an altered phenotype defined as reaching FVIII activity of  $\geq 5\%$  (5 IU/ dL).

#### 7.4 Summary of Overall Risks and Benefits

The majority of subjects in the ongoing 270-201 clinical study who have received 4E13 or 6E13 vg/kg doses of BMN 270 have had Grade 1 asymptomatic elevations in ALT. For most subjects, the elevations have reached only slightly above the ULN. Based on the effectiveness of transient oral corticosteroid use to suppress a presumed Class 1 (cytotoxic T-cell) response to hepatocytes transduced in prior studies with hepatic transduction with AAV vectors (Mingozzi, 2013), subjects were treated with 7-32 weeks of oral corticosteroids preventatively or in response to the elevations in ALT to ensure preservation of the transduced hepatocytes. Using this approach, no sustained loss of FVIII activity has been observed in subjects with ALT elevations, consistent with maintaining a high level of hepatocyte function. Moreover, the rise in ALT levels were not accompanied by significant or lasting aberrations in other liver function tests such as AST, bilirubin or albumin, indicating that extent of toxicity is limited. Overall, the literature suggests that transient elevations in liver enzymes are expected following AAV-based gene therapy for the treatment for hemophilia B without any long-term concerns of hepatic injury (Manno, 2006, *Nature Med*); (Nathwani, 2011, *N Engl J Med*); (George, 2016, *Haemophilia*); (Miesbach, 2016, *Haemophilia*).

At the highest dose tested in 270-201 (6E13 vg/kg), the majority of subjects achieved FVIII levels above 50 IU/dL at 52 weeks post-infusion. Subjects in that cohort also reported markedly decreased bleeding compared with pre-study rates and the ability to discontinue prophylactic FVIII infusions. Subjects at all dose levels continue to be followed.

The current data available for BMN 270 does not yet permit adequate assessment of the benefit:risk profile of this investigational drug. Given the monitoring measures in place in the clinical protocol(s) to minimize the risk to subjects participating in the existing studies, the identified risks are justified by the anticipated benefits that may be afforded to subjects. Each subject in 270-301 will have a comprehensive surveillance plan that monitors LFTs during the study, and elevations in LFT will be addressed according to the guidelines set forth in the protocol. Safety will be assessed by adverse event reporting and clinical laboratory assessments.

For additional information on findings in 270-201, refer to the current version of the Investigator's Brochure.

## 8 STUDY OBJECTIVES

The primary efficacy objectives of the study are to:

- Assess the efficacy of BMN 270 defined as median FVIII activity during Weeks 48-52 following intravenous infusion of BMN 270

The secondary efficacy objectives of the study are to:

- Assess the impact of BMN 270 on usage of exogenous FVIII replacement therapy from Week 5 to Week 52
- Assess the impact of BMN 270 on the number of bleeding episodes requiring exogenous FVIII replacement therapy from Week 5 to Week 52

The tertiary efficacy objectives of the study are to:

- Assess the impact of BMN 270 on patient-reported outcomes (PROs) at Week 52 of the study compared to baseline

The safety objectives of the study are to:

- Evaluate the safety of BMN 270 during the first 52 weeks following intravenous infusion
- Assess the long-term safety of BMN 270

## 9 INVESTIGATIONAL PLAN

### 9.1 Overall Study Design and Plan

This is a Phase 3, single-arm, open-label study in hemophilia A patients with residual FVIII levels  $\leq 1$  IU/dL treated continuously with prophylactic exogenous FVIII for the year prior to enrollment. Subjects will be enrolled at approximately 30 sites worldwide. Subjects must have high-quality, well-documented historical data available concerning previous bleeding episodes and exogenous FVIII usage over the previous 12 months in order to be eligible to enroll in the study.

Approximately 40 subjects will receive a 6E13 vg/kg dose of BMN 270 as an intravenous infusion. The Data Monitoring Committee (DMC) will review available safety and efficacy (eg, FVIII activity) data during the study on an ongoing basis and may determine, based on emerging data and the risk/benefit profile, that further enrollment at 6E13 vg/kg should be discontinued in favor of a different dose of BMN 270. If the DMC recommends a dosing modification, then additional subjects may be enrolled, up to a total of approximately 40 subjects, at the new BMN 270 dose level (regardless of the number of subjects previously enrolled at 6E13 vg/kg).

The final analysis for the study will be performed after all subjects have been followed for 52 weeks post-BMN 270 infusion. After the final analysis, safety and efficacy will then continue to be assessed long-term in all subjects for a total of approximately 5 years.

To avoid breakthrough bleeding, subjects will only discontinue exogenous prophylactic FVIII replacement therapy after FVIII activity has reached at least 5 IU/dL or 4 weeks following infusion of BMN 270, whichever is earlier. Four weeks represents the time by which endogenous production of FVIII following gene transfer is expected to be efficacious.

Throughout the study, subjects with FVIII activity below 5 IU/dL may be monitored more frequently at the discretion of the Medical Monitor and the Investigator.

There will be an ongoing review of individual subject safety and efficacy data by the Medical Monitor and the DMC. FVIII activity by a validated assay will be used to evaluate efficacy over the course of the study. Therapeutic oral corticosteroids may be initiated when a subject's ALT values are elevated or based on review of FVIII activity and liver enzyme data, and subsequent dosage adjustments made, after consultation between the Investigator and the Medical Monitor. Management of ALT elevations is discussed in more detail in Section [9.7.8.3](#).



|          |         |         |
|----------|---------|---------|
| B:OMARIN | 270-301 | Page 31 |
|----------|---------|---------|

Any safety signal may trigger a review of the data and possible additional immunogenicity studies or other diagnostics deemed necessary that include an assessment of cellular immune responses using collected peripheral blood mononuclear cells (PBMCs).

Schedules of assessments for the Screening and Infusion period ([Table 9.1.1](#)), Post-Infusion follow-up periods ([Table 9.1.2](#), [Table 9.1.3](#), [Table 9.1.4](#)), and during the use of oral corticosteroids ([Table 9.1.5](#)) are presented below.



|                |         |         |
|----------------|---------|---------|
| <b>BOMARIN</b> | 270-301 | Page 32 |
|----------------|---------|---------|

**Table 9.1.1: Schedule of Events – Screening and Infusion**

| Assessment  | Prior to BMN 270 Infusion      |  |  | BMN 270 Infusion Visit (Day 1) <sup>k</sup> |
|---|--------------------------------|--|--|---|
|   | Screening* (Day -28 to Day -1) | Smart Rescreening <sup>i</sup> (Day -28 to Day -1) | Baseline (Day -7 to Day -1) <sup>h</sup> |   |
| Informed consent  | X                              |  |  |   |
| Demographics (age, sex, race, ethnicity)  | X                              |  |  |   |
| Medical History   | X                              |  |  |   |
| Physical Examination <sup>a</sup>   | X                              |  | X  | X   |
| Height and Weight   | X                              |  |  |   |
| Vital Signs   | X                              | X  | X  | X   |
| Assessment of Adverse Events and Concomitant Medications  | X                              | X  | X  | X   |
| Documentation of bleeding episodes and FVIII usage for previous 12 months (by either subject or clinical information) | X                              | X  | X  |   |
| Distribution of subject diaries and training in their use <sup>l</sup>  | X                              |  |  |   |
| Electrocardiogram   | X                              |  |  |   |
| Liver Ultrasound  | X                              |  |  |   |
| hFVIII Assays <sup>b</sup>  | X                              | X <sup>j</sup>                                     | X  |   |
| AAV5 TAb Assays <sup>c</sup>  | X                              | X  | X  | X   |
| AAV5 TI Assay <sup>m</sup>  |                                |  | X  |   |
| Screen for Hepatitis B, Hepatitis C, HIV <sup>d</sup>   | X                              |  |  |   |
| Blood chemistry, hematology, and coagulation tests <sup>e</sup>   | X                              | X  | X  |   |
| Urine Tests <sup>e</sup>  | X                              | X  | X  |   |
| Liver Function Tests <sup>e</sup>   | X                              | X  | X  |   |
| PBMC collection (for baseline determination of AAV5 and FVIII specific cellular immunity)                             |                                |  | X  |   |
| Von Willebrand Factor Antigen (VWF:Ag)  | X                              |  |  |   |

|   |         |         |
|---|---------|---------|
|  | 270-301 | Page 33 |
|---|---------|---------|

| Assessment   | Prior to BMN 270 Infusion      |  |  | BMN 270 Infusion Visit (Day 1) <sup>k</sup> |
|--|--------------------------------|--|--|---|
|  | Screening* (Day -28 to Day -1) | Smart Rescreening <sup>i</sup> (Day -28 to Day -1) | Baseline (Day -7 to Day -1) <sup>h</sup> |   |
| Direct Thrombin Activity Test                                |                                |  | X  |   |
| TGA Assay  |                                |  | X  |   |
| PCR of vector DNA in blood, saliva, urine, semen, and stools |                                |  | X  | X   |
| Biomarker testing <sup>f</sup>                               | X                              |  |  |   |
| Exploratory biomarker assessments <sup>g</sup>               |                                |  | X  |   |
| Haemo-QOL-A assessment                                       |                                |  | X  |   |
| EQ-5D-5L   |                                |  | X  |   |
| HAL  |                                |  | X  |   |
| WPAI+CIQ:HS  |                                |  | X  |   |
| BMN 270 Infusion   |                                |  |  | X   |

\* Screening assessments should be performed within 28 days of BMN 270 infusion (and must be performed within 42 days prior to BMN 270 infusion).

<sup>a</sup> Complete physical examination should be done at Screening. Brief physical examination may be done at Baseline and at the BMN 270 Infusion Visit.

<sup>b</sup> Includes baseline FVIII activity (chromogenic FVIII assay and one-stage clot FVIII assay), coagulation exploratory assay, hFVIII inhibitor level (Bethesda assay with Nijmegen modification), hFVIII total antibody titer, and hFVIII protein assay. Baseline activity should be assessed at trough (at least >72 hours after last dose of replacement FVIII therapy, or 5x the known half-life of the FVIII replacement therapy administered).

<sup>c</sup> Sample collection on the day of the infusion visit must be performed before the BMN 270 infusion is given. Screening, Smart Re-screening, and Infusion Day samples will be tested in an AAV5 Tab pre-screening assay specifically developed for enrolment purposes. Baseline and all post-dose samples will be tested in a different AAV5 Tab post-dose immunogenicity monitoring assay

<sup>d</sup> Patients with documented negative results within the last 30 days do not need to be retested.

<sup>e</sup> Refer to [Table 9.7.8.2.1](#) for laboratory assessments to be included, and to [Table 9.7.8.3.1](#) for liver function tests.

<sup>f</sup> Includes HLA genotyping, FVIII genotyping, TNF $\alpha$  and IL10a single nucleotide polymorphisms.

<sup>g</sup> Blood samples will be collected from subjects to evaluate biochemical, molecular, cellular, and genetic/genomic aspects relevant to hemophilia A disease. The exploratory genetic/genomic testing on these samples is optional.

The logo for BOMARIN, featuring the word "BOMARIN" in a blue, sans-serif font. The letter "O" is stylized with three vertical bars of increasing height to its left, resembling a barcode or a molecular structure.

270-301

Page 34

- <sup>h</sup> Should the screening visit occur within 30 days of the drug infusion, physical examination, blood chemistry, LFTs, hematology, urine tests, and coagulation tests do not need to be repeated at Baseline.
- <sup>i</sup> Smart rescreening should only be performed if a patient has been determined to be eligible for the study and is unable to complete the Baseline assessments and Infusion prior to the closing of the original Screening window. Subjects who undergo smart rescreening must complete the rescreening assessments and receive the infusion within 90 days of signing the original consent. Subjects who do not complete dosing within 90 days will be required to re-consent and undergo all screening procedures. Subjects may not undergo smart rescreening more than once.
- <sup>j</sup> Only the hFVIII inhibitor level (Bethesda assay with Nijmegen modification) assay must be done at smart rescreening.
- <sup>k</sup> Assessments on the day of infusion must be performed prior to the infusion. On the day of the BMN 270 Infusion, vital signs will be monitored prior to the infusion, during the infusion every 15 minutes ( $\pm$  5 minutes), and following the infusion hourly ( $\pm$  5 minutes) for at least 8 hours during the subject's stay in the clinic.
- <sup>l</sup> Diaries should be distributed to subjects who have consented to participate in the study and who have been determined to meet all study eligibility criteria.
- <sup>m</sup> While the transduction inhibition assays will be run at Screening, they will not be used to determine inclusion/exclusion from the study.

**Table 9.1.2: Schedule of Events – Post-Infusion Follow-Up (Week 1-16)**

| Assessment  | Follow-Up After BMN 270 Infusion – Weeks* |    |    |    |    |    |    |    |    |    |    |    |    |    |    |     |     |
|---|---|----|----|----|----|----|----|----|----|----|----|----|----|----|----|-----|-----|
|   | Week 1                                    |    | 2  | 3  | 4  | 5  | 6  | 7  | 8  | 9  | 10 | 11 | 12 | 13 | 14 | 15  | 16  |
|   | D4  | D8 |    |    |    |    |    |    |    |    |    |    |    |    |    |     |     |
| Study Day*  | 4   | 8  | 15 | 22 | 29 | 36 | 43 | 50 | 57 | 64 | 71 | 78 | 85 | 92 | 99 | 106 | 113 |
| Physical examination <sup>a</sup>   |   | X  | X  | X  | X  | X  | X  | X  | X  | X  | X  | X  | X  | X  | X  | X   | X   |
| Weight <sup>a</sup>   |   |    |    |    | X  |    |    |    | X  |    |    |    | X  |    |    |     | X   |
| Assessment of Adverse Events and Concomitant Medications (including review of subject diary for bleeding and FVIII use) |   | X  | X  | X  | X  | X  | X  | X  | X  | X  | X  | X  | X  | X  | X  | X   | X   |
| Vital Signs   |   | X  | X  | X  | X  | X  | X  | X  | X  | X  | X  | X  | X  | X  | X  | X   | X   |
| Blood chemistry, hematology, and coagulation tests <sup>b</sup>   |   |    | X  |    | X  |    |    |    |    |    | X  |    |    |    |    |     | X   |
| Urine Tests <sup>b</sup>  |   |    |    |    |    |    |    |    |    |    |    |    | X  |    |    |     |     |
| Liver Function Tests <sup>b</sup>   | X   | X  | X  | X  | X  | X  | X  | X  | X  | X  | X  | X  | X  | X  | X  | X   | X   |
| FVIII assays <sup>c</sup>   |   | X  | X  | X  | X  | X  | X  | X  | X  | X  | X  | X  | X  | X  | X  | X   | X   |
| FVIII antibody titer  |   |    |    |    | X  |    |    |    | X  |    |    |    | X  |    |    |     | X   |
| PCR of vector DNA in blood, saliva, urine, semen, and stools <sup>d</sup>   | X   | X  | X  | X  | X  |    | X  |    | X  |    |    |    | X  |    |    |     | X   |
| Exploratory biomarker assessments <sup>c</sup>  |   |    |    |    |    |    | X  |    |    |    |    |    |    | X  |    |     | X   |
| Haemo-QOL-A assessment  |   |    |    |    | X  |    |    |    |    |    |    |    | X  |    |    |     |     |
| EQ-5D-5L  |   |    |    |    | X  |    |    |    |    |    |    |    | X  |    |    |     |     |

| Assessment  | Follow-Up After BMN 270 Infusion – Weeks* |    |    |    |    |    |    |    |    |    |    |    |    |    |    |     |                |
|---|---|----|----|----|----|----|----|----|----|----|----|----|----|----|----|-----|----------------|
|   | Week 1                                    |    | 2  | 3  | 4  | 5  | 6  | 7  | 8  | 9  | 10 | 11 | 12 | 13 | 14 | 15  | 16             |
|   | D4  | D8 |    |    |    |    |    |    |    |    |    |    |    |    |    |     |                |
| Study Day*  | 4   | 8  | 15 | 22 | 29 | 36 | 43 | 50 | 57 | 64 | 71 | 78 | 85 | 92 | 99 | 106 | 113            |
| HAL   |   |    |    |    | X  |    |    |    |    |    |    |    | X  |    |    |     |                |
| WPAI+CIQ:HS   |   |    |    |    | X  |    |    |    |    |    |    |    | X  |    |    |     |                |
| AAV5 TAb Assay  |   |    |    |    |    |    |    |    | X  |    |    |    |    |    |    |     | X              |
| AAV5 TI Assay   |   |    |    |    |    |    |    |    | X  |    |    |    |    |    |    |     | X              |
| Testing for reactivation of hepatitis B and hepatitis C                 |   |    |    |    |    |    |    |    |    |    |    |    |    |    |    |     | X <sup>f</sup> |
| PBMC collection (for determination of AAV5 and FVIII specific immunity) |   |    | X  |    | X  |    | X  |    | X  |    | X  |    | X  |    | X  |     | X              |
| Von Willebrand Factor Antigen (VWF:Ag)                                  |   |    |    |    |    |    |    |    |    |    |    |    |    | X  |    |     |                |
| Direct Thrombin Activity test   |   |    |    |    |    |    |    |    |    |    |    |    |    | X  |    |     |                |

\* Visit windows are  $\pm$  48 hours (and include the Day 4 visit).

<sup>a</sup> Brief physical examination should be done at all weekly visits.

<sup>b</sup> Refer to [Table 9.7.8.2.1](#) for laboratory assessments to be included, and to [Table 9.7.8.3.1](#) for liver function tests. LFTs may be monitored more or less frequently (and in particular when ALT values are  $>1.5x$  ULN) based on discussion between the Medical Monitor and the Investigator and review of subject data. Subjects with ALT  $> 1.5x$  ULN during the study and either an alternative etiology considered or for further evaluation of the lab abnormality may undergo additional evaluations (eg, imaging studies including MRI or ultrasound, additional blood tests, and/or liver biopsy) at the discretion of the Investigator. Additional testing of FVIII and LFTs during any study week may be performed if: (1) the ALT has increased to above ULN; (2) Increases in ALT values from prior assessment are accompanied by declines in FVIII activity level; or after a discussion between the Medical Monitor and the Investigator based on a review of subject data. If FVIII levels and/or ALT values are stable over the course of several weeks, assessment of FVIII activity and liver enzymes may be adjusted based on discussion between the Medical Monitor and the Investigator.

The logo for BOMARIN, featuring the word "BOMARIN" in a blue, sans-serif font. The letter "O" is stylized with three vertical bars of increasing height to its left, resembling a barcode or a molecular structure.

270-301

Page 37

- <sup>c</sup> Includes FVIII activity level (chromogenic FVIII assay and one-stage clot FVIII assay), Bethesda assay (with Nijmegen modification) for hFVIII inhibitor level, coagulation exploratory assay, and hFVIII protein assay. If FVIII levels are elevated or stable over the course of several weeks, assessment of FVIII activity may be adjusted based on discussion between the Medical Monitor and the Investigator. A D-dimer may be considered under circumstances in which FVIII activity levels are above the normal physiological range and/or if there is a concern for a venous thromboembolism.
- <sup>d</sup> Collection to occur until at least 3 consecutive negative results are obtained. Collection and testing of semen samples must continue at least through Week 12, even if 3 consecutive negative results in that compartment have already been recorded.
- <sup>e</sup> Blood samples will be collected from subjects to evaluate biochemical, molecular, cellular, and genetic/genomic aspects relevant to hemophilia A disease. The exploratory genetic/genomic testing on these samples is optional.
- <sup>f</sup> Testing for reactivation of hepatitis B and hepatitis C at Week 16 should be performed only in subjects with evidence of prior exposure and who have not received therapeutic oral corticosteroids prior to Week 16; subjects who have received therapeutic oral corticosteroids will have hepatitis B and hepatitis C testing at the time points indicated in [Table 9.1.5](#).

**Table 9.1.3: Schedule of Events – Post-Infusion Follow-Up (Week 17-32)**

| Assessment  | Follow-Up After BMN 270 Infusion – Weeks* |     |     |     |     |     |     |     |     |     |     |     |     |     |     |     |
|---|---|-----|-----|-----|-----|-----|-----|-----|-----|-----|-----|-----|-----|-----|-----|-----|
|   | 17  | 18  | 19  | 20  | 21  | 22  | 23  | 24  | 25  | 26  | 27  | 28  | 29  | 30  | 31  | 32  |
| Study Day*  | 120                                       | 127 | 134 | 141 | 148 | 155 | 162 | 169 | 176 | 183 | 190 | 197 | 204 | 211 | 218 | 225 |
| Physical examination <sup>a</sup>   | X   | X   | X   | X   | X   | X   | X   | X   | X   | X   | X   | X   | X   | X   | X   | X   |
| Weight <sup>a</sup>   |   |     |     | X   |     |     |     | X   |     |     |     | X   |     |     |     | X   |
| Assessment of Adverse Events and Concomitant Medications (including review of subject diary for bleeding and FVIII use) | X   | X   | X   | X   | X   | X   | X   | X   | X   | X   | X   | X   | X   | X   | X   | X   |
| Vital Signs   | X   | X   | X   | X   | X   | X   | X   | X   | X   | X   | X   | X   | X   | X   | X   | X   |
| Blood chemistry, hematology, and coagulation tests <sup>b</sup>   |   |     |     |     |     | X   |     |     |     | X   |     |     |     |     |     | X   |
| Urine Tests <sup>b</sup>  |   |     |     |     |     |     |     |     |     | X   |     |     |     |     |     |     |
| Liver Function Tests <sup>b</sup>   | X   | X   | X   | X   | X   | X   | X   | X   | X   | X   | X   | X   | X   | X   | X   | X   |
| FVIII assays <sup>c</sup>   | X   | X   | X   | X   | X   | X   | X   | X   | X   | X   | X   | X   | X   | X   | X   | X   |
| FVIII antibody titer  |   |     |     | X   |     |     |     | X   |     | X   |     |     |     |     |     | X   |
| PCR of vector DNA in blood, saliva, urine, semen, and stools <sup>d</sup>   |   |     |     | X   |     |     |     | X   |     | X   |     |     |     |     |     | X   |

| Assessment   | Follow-Up After BMN 270 Infusion – Weeks* |     |     |     |     |     |     |     |     |     |     |     |     |     |     |     |
|--|---|-----|-----|-----|-----|-----|-----|-----|-----|-----|-----|-----|-----|-----|-----|-----|
|  | 17  | 18  | 19  | 20  | 21  | 22  | 23  | 24  | 25  | 26  | 27  | 28  | 29  | 30  | 31  | 32  |
| Study Day*   | 120                                       | 127 | 134 | 141 | 148 | 155 | 162 | 169 | 176 | 183 | 190 | 197 | 204 | 211 | 218 | 225 |
| Exploratory biomarker assessments <sup>c</sup>                                   |   |     |     | X   |     |     |     | X   |     | X   |     |     |     |     |     | X   |
| Haemo-QOL-A assessment   |   |     |     |     |     |     |     |     |     | X   |     |     |     |     |     |     |
| EQ-5D-5L   |   |     |     |     |     |     |     |     |     | X   |     |     |     |     |     |     |
| HAL  |   |     |     |     |     |     |     |     |     | X   |     |     |     |     |     |     |
| WPAI+CIQ:HS  |   |     |     |     |     |     |     |     |     | X   |     |     |     |     |     |     |
| AAV5 TAb Assay   |   |     |     |     |     |     |     | X   |     |     |     |     |     |     |     | X   |
| AAV5 TI Assay  |   |     |     |     |     |     |     | X   |     |     |     |     |     |     |     | X   |
| PBMC collection (for determination of AAV5 and FVIII specific cellular immunity) |   | X   |     | X   |     | X   |     | X   |     | X   |     | X   |     | X   |     | X   |
| Von Willebrand Factor Antigen (VWF:Ag)   |   |     |     |     |     |     |     |     |     | X   |     |     |     |     |     |     |
| Direct Thrombin Activity Test  |   |     |     |     |     |     |     |     |     | X   |     |     |     |     |     |     |
| TGA Assay  |   |     |     | X   |     |     |     | X   |     | X   |     |     |     |     |     | X   |

\* Visit windows are  $\pm$  48 hours.

<sup>a</sup> Brief physical examination should be done at all weekly visits except Week 26, where a complete physical examination should be performed. Weight should be recorded at Week 20 and every 4 weeks.

<sup>b</sup> Refer to [Table 9.7.8.2.1](#) for laboratory assessments to be included, and to [Table 9.7.8.3.1](#) for liver function tests. LFTs may be monitored more or less frequently (and in particular when ALT values are  $>1.5x$  ULN) based on discussion between the Medical Monitor and the Investigator and review of subject



data. Subjects with ALT > 1.5x ULN during the study and either an alternative etiology considered or for further evaluation of the lab abnormality may undergo additional evaluations (eg, imaging studies including MRI or ultrasound, additional blood tests, and/or liver biopsy) at the discretion of the Investigator. Additional testing of FVIII and LFTs during any study week may be performed if: (1) the ALT has increased to above ULN; (2) Increases in ALT values from prior assessment are accompanied by declines in FVIII activity level; or after a discussion between the Medical Monitor and the Investigator based on a review of subject data. If FVIII levels and/or ALT values are stable over the course of several weeks, assessment of FVIII activity and liver enzymes may be adjusted based on discussion between the Medical Monitor and the Investigator.

<sup>c</sup> Includes FVIII activity level (chromogenic FVIII assay and one-stage clot FVIII assay), Bethesda assay (with Nijmegen modification) for hFVIII inhibitor level, coagulation exploratory assay, and hFVIII protein. If FVIII levels are elevated or stable over the course of several weeks, assessment of FVIII activity may be adjusted based on discussion between the Medical Monitor and the Investigator. A D-dimer may be considered under circumstances in which FVIII activity levels are above the normal physiological range and/or if there is a concern for a venous thromboembolism.

<sup>d</sup> Collection to occur until at least 3 consecutive negative results are obtained.

<sup>e</sup> Blood samples will be collected from subjects to evaluate biochemical, molecular, cellular, and genetic/genomic aspects relevant to hemophilia A disease. The exploratory genetic/genomic testing on these samples is optional.

|   |         |         |
|---|---------|---------|
|  | 270-301 | Page 41 |
|---|---------|---------|

**Table 9.1.4: Schedule of Events – Post-Infusion Follow-Up (Week 33 – Year 5)**

| Assessment  | Year 1 – Weeks* |     |     |     |     |     |     |     |     |     |     |     | Years 2-5        | ETV |
|---|-----------------|-----|-----|-----|-----|-----|-----|-----|-----|-----|-----|-----|------------------|-----|
|   | 33              | 34  | 35  | 36  | 38  | 40  | 42  | 44  | 46  | 48  | 50  | 52  | Q3M              |     |
| Study Day*  | 232             | 239 | 246 | 253 | 267 | 281 | 295 | 309 | 323 | 337 | 351 | 365 |                  |     |
| Physical examination <sup>a</sup>   | X               | X   | X   | X   | X   | X   | X   | X   | X   | X   | X   | X   | X <sup>a</sup>   | X   |
| Weight <sup>a</sup>   |                 |     |     | X   |     | X   |     | X   |     | X   |     | X   | X <sup>a</sup>   | X   |
| Assessment of Adverse Events and Concomitant Medications (including review of subject diary for bleeding and FVIII use) | X               | X   | X   | X   | X   | X   | X   | X   | X   | X   | X   | X   | X                | X   |
| Vital Signs   | X               | X   | X   | X   | X   | X   | X   | X   | X   | X   | X   | X   | X                | X   |
| Blood chemistry, hematology, and coagulation tests <sup>b</sup>   |                 |     |     | X   |     |     |     | X   |     |     |     | X   | X <sup>b</sup>   | X   |
| Urine Tests <sup>b</sup>  |                 |     |     |     | X   |     |     |     |     |     |     | X   | X <sup>b</sup>   | X   |
| Liver Function Tests <sup>b</sup>   | X               | X   | X   | X   | X   | X   | X   | X   | X   | X   | X   | X   | X                | X   |
| FVIII assays <sup>c</sup>   | X               | X   | X   | X   | X   | X   | X   | X   | X   | X   | X   | X   | X                | X   |
| AAV5 TAb Assay  |                 |     |     | X   |     |     |     |     |     |     |     | X   | X                | X   |
| AAV5 TI Assay   |                 |     |     | X   |     |     |     |     |     |     |     | X   | X                | X   |
| FVIII antibody titer  |                 |     |     | X   |     |     |     | X   |     |     |     | X   | X                | X   |
| Exploratory biomarker assessments <sup>e</sup>  |                 |     |     | X   |     | X   |     | X   |     | X   |     | X   | X                | X   |
| PBMC Collection (for determination of FVIII and Capsid specific cellular immunity)                                      |                 | X   |     | X   |     |     |     | X   |     |     |     | X   | X                | X   |
| Von Willebrand Factor Antigen (VWF:Ag)  |                 |     |     |     | X   |     |     |     |     |     |     | X   | X                | X   |
| Direct Thrombin Activity Test   |                 |     |     |     | X   |     |     |     |     |     |     | X   | X                | X   |
| TGA Assay   |                 |     |     | X   |     | X   |     | X   |     | X   |     | X   | X                | X   |
| PCR of vector DNA in blood, saliva, urine, semen, and stools <sup>d</sup>   |                 |     |     | X   |     | X   |     | X   |     | X   |     | X   | (X) <sup>d</sup> | X   |
| Haemo-QOL-A assessment  |                 |     |     |     |     |     |     |     |     |     |     | X   | X <sup>f</sup>   | X   |

|   |         |         |
|---|---------|---------|
|  | 270-301 | Page 42 |
|---|---------|---------|

| Assessment  | Year 1 – Weeks* |     |     |     |     |     |     |     |     |     |     |     | Years 2-5      | ETV |
|-------------|-----------------|-----|-----|-----|-----|-----|-----|-----|-----|-----|-----|-----|----------------|-----|
|             | 33              | 34  | 35  | 36  | 38  | 40  | 42  | 44  | 46  | 48  | 50  | 52  | Q3M            |     |
| Study Day*  | 232             | 239 | 246 | 253 | 267 | 281 | 295 | 309 | 323 | 337 | 351 | 365 |                |     |
| EQ-5D-5L    |                 |     |     |     |     |     |     |     |     |     |     | X   | X <sup>f</sup> | X   |
| HAL         |                 |     |     |     |     |     |     |     |     |     |     | X   | X <sup>f</sup> | X   |
| WPAI+CIQ:HS |                 |     |     |     |     |     |     |     |     |     |     | X   | X <sup>f</sup> | X   |

\* Visit windows are ± 48 hours through Week 36, then ±1 week until Week 52 and ± 2 weeks for visits in Years 2-5.

<sup>a</sup> Complete physical examination should be performed at Week 52 and every 52 weeks thereafter; brief physical exam may be performed at other study visits. Weight should be recorded at Week 36 and every 4 weeks through Week 52, then every 6 months during Years 2-5.

<sup>b</sup> Refer to [Table 9.7.8.2.1](#) for laboratory assessments to be included, and to [Table 9.7.8.3.1](#) for liver function tests. LFTs may be monitored more or less frequently (and in particular when ALT values are >1.5x ULN) based on discussion between the Medical Monitor and the Investigator and review of subject data. Subjects with ALT > 1.5x ULN during the study and either an alternative etiology considered or for further evaluation of the lab abnormality may undergo additional evaluations (eg, imaging studies including MRI or ultrasound, additional blood tests, and/or liver biopsy) at the discretion of the Investigator. Additional testing of FVIII and LFTs during any study week may be performed if: (1) the ALT has increased to above ULN or increased by > 10 U/L from prior assessment; (2) Increases in ALT values from prior assessment are accompanied by declines in FVIII activity level; or after a discussion between the Medical Monitor and the Investigator based on a review of subject data. If FVIII levels and/or ALT values are stable over the course of several weeks, assessment of FVIII activity and liver enzymes may be adjusted based on discussion between the Medical Monitor and the Investigator. During Years 2-5 of the Post-Infusion Follow-Up period, urine tests and blood, chemistry, and coagulation tests should be performed every 6 months (starting with Week 78).

<sup>c</sup> Includes FVIII activity level (chromogenic FVIII assay and one-stage clot FVIII assay), Bethesda assay (with Nijmegen modification) for hFVIII inhibitor level, coagulation exploratory assay, and hFVIII protein assay. If FVIII levels are elevated or stable over the course of several weeks, assessment of FVIII activity may be adjusted based on discussion between the Medical Monitor and the Investigator. A D-dimer may be considered under circumstances in which FVIII activity levels are above the normal physiological range and/or if there is a concern for a venous thromboembolism.

<sup>d</sup> Sample testing during Long-Term Follow-Up is not required if at least 3 consecutive samples are cleared during the Post-Infusion Follow-Up period. Subjects who have not had 3 consecutive negative semen samples by Week 52 should continue to have PCR testing of semen every 4 weeks until 3 consecutive negative samples are documented (or upon consultation between the Investigator and Medical Monitor).

<sup>e</sup> Blood samples will be collected from subjects to evaluate biochemical, molecular, cellular, and genetic/genomic aspects relevant to hemophilia A disease. The exploratory genetic/genomic testing on these samples is optional.

|   |         |         |
|---|---------|---------|
|  | 270-301 | Page 43 |
|---|---------|---------|

<sup>f</sup> PRO assessments during Years 2-5 of Long-Term Follow-up should be performed at every other visit (every 6 months) starting with the Week 78 visit (ie, 26 weeks after the Week 52 visit at the end of Year 1 of the Long-Term Follow-up period).

|   |         |         |
|---|---------|---------|
|  | 270-301 | Page 44 |
|---|---------|---------|

**Table 9.1.5: Schedule of Events – Therapeutic Corticosteroids for LFT Elevations or Decreased FVIII Activity**

|   | Steroid Treatment Period <sup>b</sup> |        |        |        |        |        |        |                     | Post-Steroid Period <sup>c</sup> |        |        |        |         |
|---|---------------------------------------|--------|--------|--------|--------|--------|--------|---------------------|----------------------------------|--------|--------|--------|---------|
|   | Week 1                                | Week 2 | Week 3 | Week 4 | Week 5 | Week 6 | Week 7 | Week 8 <sup>b</sup> | Week 1                           | Week 2 | Week 3 | Week 4 | Week 13 |
| Therapeutic corticosteroids (dose in mg/day) <sup>a</sup> | 60 mg                                 | 60 mg  | 40 mg  | 40 mg  | 40 mg  | 30 mg  | 20 mg  | 10 mg               |                                  |        |        |        |         |
| FVIII activity testing                                    |                                       |        |        |        |        |        |        |                     | X                                | X      | X      | X      |         |
| Liver function testing                                    |                                       |        |        |        |        |        |        |                     | X                                | X      | X      | X      |         |
| Hepatitis B testing <sup>d</sup>                          |                                       |        |        |        |        | X      |        |                     | X                                |        |        |        | X       |
| HCV Viral Load <sup>d</sup>                               |                                       |        |        |        |        | X      |        |                     | X                                |        |        |        | X       |

<sup>a</sup> Therapeutic oral corticosteroids may be initiated according to the parameters set out in Section 9.4.8.2.

<sup>b</sup> Following initiation or completion of steroid regimen, if a recurrence of ALT values > 1.5x ULN is reported, steroid management decisions will be based on discussions between the Investigator and Medical Monitor. Modification of the steroid regimen may take into consideration possible confounders for the ALT elevation, relationship between increases in ALT and FVIII activity, ALT/FVIII levels post steroid initiation, and adverse events related to steroid dosing. Guidance for tapering oral corticosteroid dosing can be found in Section 9.4.8.2.

<sup>c</sup> After discontinuation of oral corticosteroids, weekly labs for ALT and FVIII levels will be measured once a week for 4 weeks to ensure stability in values. If these assessments are already being done as part of normal study follow-up, they do not need to be duplicated.

<sup>d</sup> Should only be performed in subjects with a history of hepatitis B or hepatitis C.

## 9.2 Discussion of Study Design, Including Choice of Control Group

Study 270-301 is designed to be a Phase 3, single-arm, open-label study in hemophilia A patients with residual FVIII levels  $\leq 1$  IU/dL previously treated with prophylactic exogenous FVIII. Hemophilia A patients who provide written informed consent, meet the entry criteria definition of residual FVIII activity, have well-documented historical data for the previous 12 months concerning exogenous FVIII usage and bleeding episodes, and do not have antibodies to AAV5 will be eligible to enroll in the study.

Approximately 40 subjects will be enrolled at the 6E13 vg/kg BMN 270 dose. Subjects will be followed for 52 weeks post-BMN 270 infusion during which safety and efficacy assessments will be taken. After the final analysis at 52 weeks post-infusion, safety and efficacy will then continue to be assessed long-term for approximately a total of 5 years. During enrollment, the DMC will review available safety and efficacy data on an ongoing basis and may decide to recommend dosing subjects at a different dose level based on emerging data from 270-301 and their overall benefit:risk assessment.

Study 270-301 is a self-controlled study. Parameters for each subject will be compared to a pre-treatment assessment of safety (liver function) and efficacy (number of bleeds, use of FVIII replacement therapy).

## 9.3 Selection of Study Population

Approximately 40 hemophilia A patients with residual FVIII levels  $\leq 1$  IU/dL may enroll into the study.

Additional criteria for participation in the study are provided in Section [9.3.1](#) and Section [9.3.2](#).

### 9.3.1 Inclusion Criteria

Individuals eligible to participate in this study must meet all of the following inclusion criteria:

1. Males  $\geq 18$  years of age with hemophilia A and residual FVIII levels  $\leq 1$  IU/dL as evidenced by medical history, at the time of signing the informed consent.
2. Must have been on prophylactic FVIII replacement therapy for at least 12 months prior to study entry. High-quality, well-documented historical data concerning bleeding episodes and FVIII usage over the previous 12 months must be available.
3. Treated/exposed to FVIII concentrates or cryoprecipitate for a minimum of 150 exposure days (EDs).

|          |         |         |
|----------|---------|---------|
| B:OMARIN | 270-301 | Page 46 |
|----------|---------|---------|

4. Willing and able to provide written, signed informed consent after the nature of the study has been explained and prior to any study-related procedures.
5. No history of FVIII inhibitor, and results from a Bethesda assay with Nijmegen modification of less than 0.6 Bethesda Units (BU) on 2 consecutive occasions (the most recent one of which should be tested at the central laboratory) at least one week apart within the past 12 months
6. Sexually active participants must agree to use an acceptable method of double barrier contraception for at least 6 months post-infusion, which may include hormonal contraception for a female partner. After 6 months, subjects may stop contraception use only if they have had 3 consecutive semen samples with no detectable viral vector DNA.
7. Willing to abstain from alcohol consumption for at least the first 52 weeks following BMN 270 infusion.
8. HIV positive patients may be enrolled, only if the patient has a CD4 count  $> 200/\text{mm}^3$  and an undetectable viral load.

### 9.3.2 Exclusion Criteria

Individuals who meet any of the following exclusion criteria will not be eligible to participate in the study:

1. Detectable pre-existing antibodies to the AAV5 capsid.
2. Any evidence of active infection or any immunosuppressive disorder, except for HIV infection as described in the inclusion criterion above.
3. Significant liver dysfunction with any of the following abnormal laboratory results:
  - ALT (alanine transaminase) or AST  $>2\text{X ULN}$ ;
  - Total bilirubin  $>2\text{X ULN}$ ;
  - Alkaline phosphatase  $>2\text{X ULN}$ ; or
  - INR (international normalized ratio)  $\geq 1.4$ .

Subjects whose liver laboratory assessments fall outside of these ranges may undergo repeat testing and, if eligibility criteria are met on retest, may be enrolled after confirmation by the Medical Monitor. In addition, subjects with abnormal laboratory results related to confirmed benign liver conditions (eg, Gilbert's syndrome) are considered eligible for the study notwithstanding their abnormal laboratory results and may be enrolled after discussion with the Medical Monitor.

4. Prior liver biopsy showing significant fibrosis of 3 or 4 as rated on a scale of 0-4 on the Batts-Ludwig (Batts 1995) or METAVIR (Bedossa 1996) scoring systems, or an equivalent grade of fibrosis if an alternative scale is used.
5. Evidence of any bleeding disorder not related to hemophilia A.



6. Platelet count of  $< 100 \times 10^9/L$ .
7. Creatinine  $\geq 1.5$  mg/dL.
8. Liver cirrhosis of any etiology as assessed by liver ultrasound.
9. Chronic or active hepatitis B as evidenced by positive serology testing and confirmatory HBV DNA testing. Refer to the Centers for Disease Control (CDC) table for the interpretation of serological test results in the Laboratory Manual.
10. Active Hepatitis C as evidenced by detectable HCV RNA or currently on antiviral therapy.
11. Active malignancy, except non-melanoma skin cancer.
12. History of hepatic malignancy.
13. History of arterial or venous thromboembolic events (eg, deep vein thrombosis, non-hemorrhagic stroke, pulmonary embolism, myocardial infarction, arterial embolus), with the exception of catheter-associated thrombosis for which anti-thrombotic treatment is not currently ongoing.
14. Known inherited or acquired thrombophilia, including conditions associated with increased thromboembolic risk, such as atrial fibrillation.
15. Treatment with any Investigational Product within 30 days prior to the screening period. For subjects who have received a prior investigational product, all ongoing adverse events (AEs) experienced while receiving that investigational product must have resolved prior to screening for this study.
16. Any condition that, in the opinion of the Investigator or Sponsor would prevent the patient from fully complying with the requirements of the study (including possible corticosteroid treatment outlined in the protocol) and/or would impact or interfere with evaluation and interpretation of subject safety or efficacy result.
17. Prior treatment with any vector or gene transfer agent.
18. Major surgery planned in the 52-week period following the infusion with BMN 270.

Use of systemic immunosuppressive agents, not including corticosteroids, or live vaccines within 30 days before the BMN 270 infusion.

Concurrent enrollment in another clinical study, unless it is an observational (non-interventional) clinical study that does not interfere with the requirements of the current protocol or have the potential to impact the evaluation of efficacy and safety of BMN 270 and with prior consultation with the Medical Monitor.

Known allergy or hypersensitivity to BMN 270 investigational product formulation.

Unwilling to receive blood or blood products for treatment of an adverse event and/or a bleeding episode.

### 9.3.3 Removal of Subjects from Treatment or Assessment

Subjects may withdraw their consent to participate in the study at any time without prejudice. The Investigator must withdraw from the study any subject who requests to be withdrawn. Such subjects will always be asked about the reason(s) for withdrawal. The Investigator will discuss with the subject appropriate procedures for withdrawal from the study. The Investigator should ask the subject's consent to perform the procedures listed under the early termination visit. Should a subject withdraw from the study, all efforts will be made to complete and report the observations as thoroughly as possible up to the date of the withdrawal.

A subject's participation in the study may be discontinued at any time at the discretion of BioMarin or of the Investigator and in accordance with his/her clinical judgment. When possible, the tests and evaluations listed for the termination visit should be carried out and every effort will be made to gather follow-up safety data if possible.

BioMarin must be notified of all subject withdrawals as soon as possible. BioMarin also reserves the right to discontinue the study at any time for either clinical or administrative reasons and to discontinue participation by an individual Investigator or site for poor enrollment or noncompliance.

Reasons for which the Investigator or BioMarin may withdraw a subject from the study include, but are not limited to, the following:

- Subject requires medication or medical procedure prohibited by the protocol
- Subject does not adhere to study requirements specified in the protocol
- Subject was erroneously enrolled into the study or does not meet entry criteria and not yet been dosed with BMN 270; subjects who do not meet entry criteria but who erroneously receive BMN 270 should remain in the study for safety monitoring
- Subject is lost to follow-up

If a subject fails to return for scheduled visits, a documented effort must be made to determine the reason. If the subject cannot be reached by telephone, a certified letter should be sent to the subject requesting contact with the Investigator. This information should be recorded in the study records.

The Investigator or designee must explain to each subject, before enrollment into the study, that for evaluation of study results, the subject's protected health information obtained during the study may be shared with the study Sponsor, regulatory agencies, and IRB/IEC/REB. It is the Investigator's (or designee's) responsibility to obtain written permission to use protected

health information per country-specific regulations, such as the Health Insurance Portability and Accountability Act (HIPAA) in the US, from each subject. If permission to use protected health information is withdrawn, it is the Investigator's responsibility to obtain a written request, to ensure that no further data will be collected from the subject and the subject will be removed from the study.

### 9.3.3.1 Study Safety Evaluation Criteria

If any of the following events occur in a subject in the study who has received BMN 270 infusion, an urgent evaluation by the DMC will be required and further enrollment into the trial may be temporarily put on hold if recommended by the DMC per Section 9.1.

1. Liver dysfunction (criteria do not apply to ALT elevations with an extra-hepatic etiology):
  - ALT >5x ULN, for more than 2 weeks
  - ALT >3x ULN **and** (total bilirubin >2x ULN **or** INR >1.5)
  - ALT >3x ULN with signs and symptoms of liver dysfunction
2. The occurrence of Grade 4 or Grade 5 adverse events assessed as related to study drug (events of liver dysfunction are defined above).
3. The occurrence of an AE of hepatic failure.
4. The detection of high-titer neutralizing antibodies (>5 BU) to hFVIII following BMN 270 infusion in two subjects.
5. The occurrence of any cancer (except non-melanoma skin cancer) at any point after BMN 270 infusion.
6. The occurrence of a thromboembolic event with FVIII activity > 150 IU/dL in one subject.

If any of the following events occurs in a subject in the study who has received BMN 270 infusion, an urgent evaluation by the DMC will be required. Further enrollment into the trial will continue while DMC evaluation is ongoing, unless deemed otherwise by the DMC:

1. The detection of high-titer neutralizing antibodies (>5 BU) to hFVIII following BMN 270 infusion in one subject
2. Occurrence of a thromboembolic event in one subject

### 9.3.4 Subject Identification and Replacement of Subjects

Each subject will be assigned a unique subject identifier. This unique identifier will be on all eCRF pages. In legal jurisdictions where use of initials is not permitted, a substitute identifier will be used.

Subjects who withdraw from the study after receiving BMN 270 will not be replaced.

### **9.3.5 Duration of Subject Participation**

The duration of participation for each subject will be approximately 264 weeks. This includes 4 weeks of screening, 1 day of BMN 270 infusion, 52 weeks of Post-Infusion Follow-Up, and 208 weeks of Long-Term Follow-Up.

## **9.4 Treatments**

### **9.4.1 Treatments Administered**

BioMarin and/or its designee will provide the study site with a supply of IP sufficient for the completion of the study. BioMarin is responsible for shipping study drug to clinical sites.

### **9.4.2 Identity of Investigational Product**

#### **9.4.2.1 Product Characteristics and Labeling**

BMN 270 is a sterile, clear, colorless-to-pale yellow solution for IV infusion and is supplied in a 2 mL polypropylene cryovial. Each vial contains 1.1 mL of AAV5-hFVIII-SQ at a concentration of 2E13 vector genomes per mL in a pH 7.4 phosphate buffer.

The study drug label includes the following information: lot number, required storage conditions, a precautionary statement, expiry date, study number, and BioMarin name and address. Labelling will be done according to country specific requirements.

#### **9.4.3 Storage**

At the study site, all IP must be stored under the conditions specified in the Pharmacy Manual in a secure area accessible only to the designated pharmacists and clinical site personnel. All IP must be stored and inventoried and the inventories must be carefully and accurately documented according to applicable state, federal and local regulations, ICH GCP, and study procedures.

#### **9.4.4 Directions for Administration**

After a physical examination performed by the Investigator or designee, participants will be admitted on the day of BMN 270 infusion. If the subject is found to have an active acute illness at the time of planned infusion, then the infusion should be deferred until the illness has resolved; screening procedures may require repetition if outside the specified window. An IV catheter will be inserted into a suitable peripheral vein (eg, the median cubital vein) and flushed with saline. FVIII replacement therapy will not be given since venipuncture is a minimally invasive procedure in these individuals under ordinary conditions.

BMN 270 will be prepared and infused as a pure solution over a dose-dependent time. Prepared drug will be kept at room temperature prior to administration. An electric syringe pump will be used to infuse through an in-line, low protein binding 0.22 micron filter. BMN 270 will be infused through the catheter using an appropriate infusion pump at a constant rate of 4 mL/min while monitoring the vital signs (pulse, blood pressure, respiration rate and temperature) at 15 minute ( $\pm 5$  minutes) intervals. The anticipated maximum interval from initiation of thawing of BMN 270 to completion of the infusion is 4 hours, although the IP has been shown to be stable at room temperature for 6 hours.

Following completion of the infusion, vital signs will be monitored hourly ( $\pm 5$  minutes). If the vital signs are stable the catheter will be removed 8 hours after the infusion. Hemostasis at the puncture site will be established by applying pressure according to standard protocol for infusing FVIII concentrates. Subjects will remain in the clinic for at least 8 hours to observe for any immediate toxicity of the procedure; in-patient observation can be extended beyond 8 hours if needed per Investigator discretion. After 8 hours, participants will be discharged from the clinic unless toxicity has been observed in which case the stay in the clinic may be extended or the subject may transfer to a separate facility based on the evaluation and judgment of the Principal Investigator after consultation with the Medical Monitor.

#### 9.4.5 Method of Assigning Subjects to Treatment Groups

Subjects who meet all eligibility criteria (refer to Section 9.3.1 and Section 9.3.2) may be enrolled into the study. Approval by the Medical Monitor will be required prior to enrollment of each study subject. Upon their enrollment into the study, subjects will be assigned a unique subject number by the Sponsor.

Approximately 40 subjects will be enrolled at 6E13 vg/kg.

#### 9.4.6 Selection of Dose Used in the Study

Data from an ongoing first in human study (Clinical Study 270-201) indicates that following single escalated doses of BMN 270 (6E12, 2E13, 4E13, 6E13 vg/kg), dose-related increases in FVIII activity were observed, with concurrent improvements in bleeding episodes and exogenous FVIII utilization, particularly at the 4E13 and 6E13 vg/kg dose levels. At all dose levels, BMN 270 is considered to be well-tolerated with mild increases in ALT as the most common adverse event. Please refer to the IB for detailed efficacy and safety data.

In order to further evaluate the dose-response relationship of BMN 270, subjects will be enrolled at a dose of 6E13 vg/kg. This dose is expected to be safe and effective based on clinical experience to date in 270-201. The DMC will review emerging safety and efficacy

data and may recommend that a different dose be administered. In such a case, up to 40 additional subjects may be enrolled at the new dose.

#### 9.4.7 Blinding

This is an open-label study.

#### 9.4.8 Prior and Concomitant Medications

All prescription and over-the-counter medications (including dietary and herbal supplements) taken by a subject for 30 days before Screening will be recorded on the designated eCRF. The Investigator may prescribe additional medications, deemed necessary to provide adequate prophylactic or supportive care, during the study, as long as the prescribed medication is not prohibited by the protocol. In the event of an emergency, any needed medications may be prescribed without prior approval, but the Medical Monitor must be notified of the use of any contraindicated medications immediately thereafter. Any concomitant medications added or discontinued during the study should be recorded on the eCRF. Medications should, whenever possible, not be recorded in the electronic database with a frequency of PRN.

The following medications are prohibited starting 30 days before Screening and through the end of the study, and the Sponsor must be notified if a subject receives any of these during the study:

- Any investigational therapy
- Systemic immunosuppressive agents, except for corticosteroids

The following medications should be avoided, starting 30 days prior to and for at least 52 weeks after BMN 270 infusion and minimized throughout the remaining duration of the study.

- Alcohol
- Herbal and natural remedies and dietary supplements
- Medications which may be hepatotoxic

Vaccines should also be avoided during this period, but in particular during the first 26 weeks unless clinically indicated.

The following medications should be avoided during oral corticosteroid therapy:

- Vaccines
- NSAIDs

#### 9.4.8.1 Concomitant Hemophilia Treatments

Subjects on prophylactic FVIII therapy will discontinue their regular treatment regimen starting 4 weeks following the day of infusion or after FVIII activity has reached at least 5 IU/dL (whichever is earlier) and switch to an “on-demand” schedule. FVIII replacement therapy can always be taken as needed by the subject for treatment of an acute bleeding episode; the subject must carefully record his treatment and bleeding episodes in his diary. Prophylactic FVIII use can be used on a case-by-case basis and in consultation with the Medical Monitor to prevent bleeding in extenuating circumstances (eg, peri-operative).

In addition, information on FVIII usage and bleeding episodes by medical history must be well-documented and available and will be collected from subjects for the 12-month period immediately preceding study enrollment. Further information on the details that should be provided as part of the subject’s well-documented medical and FVIII usage history are provided in the Study Reference Manual.

In order to enable rigorous comparisons of pre-study versus on-study FVIII usage and bleeding episodes, the Medical Monitor will review each screened patient’s prior bleed and hemophilia medication logs to determine if they are of “high-quality”. Elements that will be assessed to judge the quality of such historical data may include, but are not limited to, the following:

- Date, type (eg, joint, muscle, other), location of bleeds
- Date, name, dose (calculated in IU/kg), and reason for use (eg, usual prophylaxis, one-time prophylaxis, treatment for bleed, surgery) of hemophilia medications.

#### 9.4.8.2 Therapeutic Glucocorticoid Treatment of Elevated Hepatic Transaminases

Therapeutic oral corticosteroids (prednisone or converted equivalent) should be initiated when either of the following occurs post-BMN 270 infusion in any subject and after consultation with the Medical Monitor (or their designee if consultation is required outside of the Medical Monitor's waking hours):

- $ALT \geq 1.5x$  ULN
  - Whenever possible, a confirmatory lab draw for ALT should be performed, along with FVIII activity, prior to initiating oral corticosteroids.
  - Corticosteroids may be delayed if elevations in ALT are clearly not related to BMN 270 (eg, elevated in ALT with concurrent increase in CPK due to intensive exercise)



|          |         |         |
|----------|---------|---------|
| B:OMARIN | 270-301 | Page 54 |
|----------|---------|---------|

In addition, if FVIII activity drops > 50% at any time post-BMN 270 infusion, a course of therapeutic oral corticosteroids should be considered upon consultation between the Investigator and the Medical Monitor.

The prescribed regimen for therapeutic oral corticosteroids is detailed in [Table 9.1.5](#). Changes to the corticosteroid regimen should be made as follows:

**Table 9.4.8.2.1: Adjustments to Corticosteroid Regimen**

|                                       |   |  |
|---------------------------------------|---|--|
| <b>Tapering Corticosteroid Dose</b>   | Subject has been receiving oral corticosteroids <3 weeks  | Corticosteroids may be discontinued <b>if</b> : <ul style="list-style-type: none"> <li>• ALT &lt;1.5 ULN; and</li> <li>• FVIII levels &gt; 20 IU/dL and within 10% of the pre-decline FVIII levels; and</li> <li>• There is no concern for adrenal insufficiency post-withdrawal</li> </ul>            |
|                                       | Subject has been receiving oral corticosteroids ≥3 weeks  | Corticosteroids may be tapered by 10 mg weekly <b>if</b> : <ul style="list-style-type: none"> <li>• ALT &lt;1.5 ULN; and</li> <li>• FVIII levels &gt; 20 IU/dL and within 10% of the pre-decline FVIII levels; and</li> <li>• There is no concern for adrenal insufficiency post-withdrawal</li> </ul> |
| <b>Increasing Corticosteroid Dose</b> | If ALT level is increasing or FVIII level is decreasing while on oral corticosteroids, any increases in oral corticosteroid dosing should be made only upon consultation with the Medical Monitor |  |

After discontinuation of oral corticosteroids, labs for ALT and FVIII levels will be measured once a week for 4 weeks to ensure stability in values.

Following initiation or completion of therapeutic oral corticosteroids, if ALT elevation ≥1.5x ULN is reported, corticosteroid management decisions will be based on discussions between the Investigator and Medical Monitor. Modification of the corticosteroid regimen may take into consideration possible confounders for the ALT elevation and impact on FVIII expression.

Management and monitoring of reactions to corticosteroids should be determined by the Investigator's clinical judgment in consultation with the Sponsor's Medical Monitor. This includes the contraindicated use of NSAIDs during corticosteroid treatment and specific monitoring not already covered by the schedule of events. The use of COX-2 inhibitors, while not contraindicated during corticosteroid treatment, should be limited, if possible. Practical management to prevent complications related to oral corticosteroid therapy may be undertaken at the discretion of the Investigator (eg, evaluation of glucose intolerance, hyperlipidemia etc.). Hepatitis B status and HCV viral load will be rechecked 6 weeks after the start of oral corticosteroid treatment and then 1 week and 13 weeks after the completion

of oral corticosteroid treatment. All adverse events (including any adverse events suspected to be caused by or related to corticosteroid use) should be reported as outlined in Section 10 of the protocol.

#### **9.4.8.3 Monitoring of HIV-Positive Subjects**

HIV-positive subjects may be enrolled in 270-301 if the subject has a CD4 count  $> 200/\text{mm}^3$  and an undetectable viral load.

Subjects should continue anti-retroviral therapy (ART) as prescribed and follow routine monitoring of CD4 count and viral load ([US Dept Health Human Services, 2014](#)). No alterations in the monitoring are indicated for enrolled immunocompetent HIV-positive subjects who receive corticosteroids as part of their enrollment in 270-301.

#### **9.4.9 Treatment Compliance**

Study drug will be administered to subjects at the study site and/or the dosing facility by a qualified health care professional. The quantity dispensed, returned, used, lost, etc. must be recorded on the dispensing log provided for the study. Sites will be instructed to return or destroy all used and unused study drug containers.

### **9.5 Investigational Product Accountability**

The Investigator or designee is responsible for maintaining accurate records (including dates and quantities) of IP(s) received and IP lost or accidentally or deliberately destroyed. The Investigator or designee must retain all unused or expired study supplies until the study monitor (on-site CRA) has confirmed the accountability data.

#### **9.5.1 Return and Disposition of Clinical Supplies**

Unused study drug must be kept in a secure location for accountability and reconciliation by the study monitor. The Investigator or designee must provide an explanation for any destroyed or missing study drug or study materials.

Unused study drug may be destroyed on site, per the site's standard operating procedures, but only after BioMarin has granted approval for drug destruction. The monitor must account for all study drug in a formal reconciliation process prior to study drug destruction. All study drug destroyed on site must be documented. Documentation must be provided to BioMarin or designee and retained in the Investigator study files. If a site is unable to destroy study drug appropriately, the site can return unused study drug to BioMarin upon request. The return of study drug or study drug materials must be accounted for on a Study Drug Return Form provided by BioMarin.

All study drug and related materials should be stored, inventoried, reconciled, and destroyed or returned according to applicable state and federal regulations and study procedures. For additional information, please refer to the Study Pharmacy Manual.

## 9.6 Dietary or Other Protocol Restrictions

There are no dietary or other protocol restrictions for this study. Alcohol should be avoided for the first 52 weeks of the study, and particularly within 48 hours prior to lab work.

## 9.7 Safety and Efficacy Variables

### 9.7.1 Safety and Efficacy Measurements Assessed

The Schedule of Events ([Table 9.1.1](#) through [Table 9.1.4](#)) describes the timing of required evaluations.

### 9.7.2 Primary Efficacy Variables

#### 9.7.2.1 FVIII Activity

The primary efficacy variable is change of the median hFVIII activity during Weeks 48-52 post-BMN 270 infusion from baseline using a validated assay. Values for FVIII activity will be excluded if obtained within 72 hours since the last infusion of exogenous FVIII protein concentrates (or within 5x the known half-life of the FVIII c administered).

In the event of an FVIII activity level decline during the study:

- If FVIII activity has declined at least 20% from the peak but less than 35% and has declined for at least 2 consecutive assessments, FVIII activity and LFTs should be repeated every 7 days until FVIII activity is stable or increasing
- If FVIII activity has declined >35% from the peak and has declined for at least 2 consecutive assessments, FVIII activity and LFTs should be repeated every 72 hours until FVIII activity is stable or increasing

Note that fluctuations in FVIII activity are common, and if no clear trend indicating a decline in FVIII activity is observed, then this additional testing may be deferred (upon consultation between the Investigator and the Medical Monitor) until either a more clear trend of decline has been demonstrated or until the FVIII activity levels stabilize or increase.

Details on collecting FVIII activity samples are included in the Laboratory Manual.

|                 |         |         |
|-----------------|---------|---------|
| <b>B:OMARIN</b> | 270-301 | Page 57 |
|-----------------|---------|---------|

### 9.7.3 Secondary Efficacy Variables

#### 9.7.3.1 Factor VIII Replacement Therapy/Bleeding Episodes

Secondary efficacy variables are:

- Change of the annualized utilization (IU/kg) of exogenous FVIII replacement therapy during Week 5 to Week 52 post BMN 270 infusion from the baseline utilization of exogenous FVIII replacement therapy calculated using subjects' historical medical records during the year prior to the enrollment.
- Change in the annualized number of bleeding episodes requiring exogenous FVIII replacement treatment during Week 5 to Week 52 of the study post BMN 270 infusion from the baseline ABR calculated using subjects' historical medical records during the year prior to the enrollment.

Subjects must have high quality documented historical data available concerning previous bleeding episodes and exogenous FVIII usage over the previous 12 months in order to be eligible to enroll in the study. During the study, subjects will be asked at each study visit to report the use of factor replacement therapy and the number of bleeding episodes since the previous visit. This information will be captured on the subject's diary or other subject records.

Subjects are strongly encouraged to immediately consult Investigator for guidance regarding exogenous FVIII administration for suspected bleeds or bleeding episodes within the first 30 days post BMN 270 infusion.

### 9.7.4 Tertiary Efficacy Variables

#### 9.7.4.1 Patient-Reported Outcomes (PRO)

The Haemo-QoL-A questionnaire is a validated hemophilia-specific health-related quality of life questionnaire for adults ([Rentz, 2008, Haemophilia](#)). It consists of 41 questions covering six domains (Physical Functioning, Role Functioning, Worry, Consequences of Bleeding, Emotional Impact and Treatment Concerns). Items are answered on a 6-point Likert-type scale, ranging from 0 (None of the time) to 5 (All of the time). Higher scores mean better health-related quality of life or less impairment for a particular subscale ([Haemo-QoL Study Group, 2017](#)). Details regarding the Haemo-QoL-A assessment will be included in the Study Reference Manual.

The EQ-5D-5L instrument is a self-reported questionnaire designed to measure general health status ([The EuroQol Group, 1990, Health Policy](#)) ([Brooks, 1996, Health Policy](#)).

The EQ-5D-5L is composed of 2-parts: a descriptive system that assesses 5 levels of perceived problems (mobility, self-care, usual activities, pain/discomfort, and anxiety/depression) in 5 dimensions and the EQ visual analogue scale (EQ VAS) assessment for overall health. A sample copy of the EQ-5D-5L and additional information are provided in the Study Reference Manual.

The Haemophilia Activities List (HAL) measures the impact of hemophilia on self-perceived functional abilities in adults ([ven Genderen, 2006](#)). The instrument consists of multiple domains including lying/sitting/kneeling/standing, leg and arm function, use of transportation, self-care, household tasks, and leisure activities where subjects are asked to rate their level of difficulty with activities of daily living on a 6-point Likert-type scale from 1 (Impossible) to 6 (Never). For some items, subjects are given the choice to answer 'Not applicable'. A sample copy of the HAL and additional information are provided in the Study Reference Manual.

The Work Productivity and Activity Impairment plus Classroom Impairment Questions: Hemophilia Specific (WPAI+CIQ:HS) instrument is designed to measure the effect of disease symptom severity on work productivity and classroom productivity (if applicable) ([Recht, 2014](#)). The WPAI+CIQ:HS questionnaire yields scores related to work/classroom absenteeism, reduced on-the-job effectiveness, overall work/classroom impairment, and activity impairment. WPAI+CIQ:HS outcomes are expressed as impairment percentages, with higher numbers indicating greater impairment and less productivity ([Reilly, 2002](#)). A sample copy of the WPAI+CIQ:HS and additional information are provided in the Study Reference Manual.

### 9.7.5 Immunogenicity

Immunogenicity assays will be performed on plasma and PBMCs. The assays will include detection of anti-AAV5 capsid and anti-FVIII total antibodies, as well as determination of neutralizing antibodies against FVIII (FVIII inhibitors) and against the AAV5 capsid (Transduction Inhibitors, TI). FVIII Inhibitors will be assessed using the Bethesda assay with Nijmegen modification. Any abnormality of the liver parameters will lead to a retrospective immunogenicity assessment to evaluate FVIII- and capsid-specific cellular immunogenicity. FVIII- and capsid-specific cellular immunity will be assessed by stimulated cytokine secretion using an ELISpot assay performed on collected PBMCs.

### 9.7.6 Pharmacodynamics

The FVIII protein concentration and activity level as measured by a validated immunoassay and by a validated FVIII activity assay, respectively, will be used for plasma profiles; FVIII protein and activity will be used to determine PD parameters.

### 9.7.7 Exploratory Assessments

Blood samples will be collected from subjects at the time points indicated in [Table 9.1.1](#), [Table 9.1.2](#), [Table 9.1.3](#), and [Table 9.1.4](#) to evaluate biochemical, molecular, cellular, and genetic/genomic aspects relevant to hemophilia A, and to develop assays used for these evaluations. The exploratory genetic/genomic research to study or try to discover genes that are not yet known to be associated with hemophilia A is optional.

All biomarker samples collected in this study may be used for exploratory biomarker research, including evaluation of additional biomarkers not specifically listed in the protocol. In addition, samples collected for other purposes in this study may be used for exploratory research once testing for the primary purpose has been completed.

### 9.7.8 Safety Variables

Safety in this study will be determined from evaluation of AEs, clinical laboratory assessments with a particular attention to the liver function, vital signs assessments, physical examinations, and immunogenicity.

#### 9.7.8.1 Adverse Events

The determination, evaluation and reporting of AEs will be performed as outlined in [Section 10](#).

#### 9.7.8.2 Clinical Laboratory Assessments

The scheduled clinical laboratory tests are listed in [Table 9.7.8.2.1](#). Refer to the Study Reference Manual for instructions on obtaining and shipping samples.

Any abnormal test results determined to be clinically significant by the Investigator should be repeated (at the Investigator's discretion) until: (1) the cause of the abnormality is determined; (2) the value returns to baseline or to within normal limits; or (3) the Investigator determines that the abnormal value is no longer clinically significant.

All abnormal clinical laboratory results should be initialed and dated by an Investigator, along with a comment regarding whether or not the result is clinically significant. Each clinically significant laboratory result should be recorded as an adverse event.

|                 |         |         |
|-----------------|---------|---------|
| <b>B:OMARIN</b> | 270-301 | Page 60 |
|-----------------|---------|---------|

The diagnosis, if known, associated with abnormalities in clinical laboratory tests that are considered clinically significant by the Investigator will be recorded on the AE eCRF.

**Table 9.7.8.2.1: Clinical Laboratory Tests**

| <b>Blood Chemistry</b> | <b>Hematology</b>         | <b>Urine Tests</b> | <b>Coagulation Screen</b><br>including: |
|------------------------|---------------------------|--------------------|---|
| Albumin                | Hemoglobin                | Appearance         | APTT                                    |
| BUN                    | Hematocrit                | Color              | PT/INR                                  |
| Calcium                | WBC count                 | pH                 | TT                                      |
| Chloride               | RBC count                 | Specific gravity   |   |
| Total cholesterol      | Platelet count            | Ketones            |   |
| CPK                    | Differential cell count   | Protein            |   |
| Creatinine             | RBC indices (MCV and MCH) | Glucose            |   |
| CRP                    |                           | Bilirubin          |   |
| Glucose                |                           | Nitrite            |   |
| Phosphorus             |                           | Urobilinogen       |   |
| Potassium              |                           | Hemoglobin         |   |
| Total protein          |                           |                    |   |
| Sodium                 |                           |                    |   |
| Uric Acid              |                           |                    |   |

BUN, blood urea nitrogen; CPK, creatinine phosphokinase; CRP, C-reactive protein; PT, prothrombin time; APTT, activated partial thromboplastin time; RBC, red blood cell; WBC, white blood cell; TT, thrombin time; INR, international normalized ratio; MCV, mean corpuscular volume; MCH, mean corpuscular hemoglobin.

### 9.7.8.3 Liver Function and Hepatitis Testing

Subjects will be screened for evidence of previous or active hepatitis B or hepatitis C infection at Screening. Subjects with documented results showing an absence of active hepatitis B or hepatitis C infection (as measured by positive surface antigen for hepatitis B or positive RNA testing for hepatitis C) 30 days prior to providing signed informed consent do not need to repeat those tests during the screening period.

Evidence of ongoing hepatitis B or hepatitis C infection is exclusionary. Subjects who have cleared a Hepatitis B infection or are seronegative do not need to receive the Hepatitis B vaccination. Subjects with evidence of prior exposure will be tested for hepatitis B and hepatitis C reactivation at Week 16. Subjects who receive therapeutic oral corticosteroids prior to Week 16 do not need to complete the Week 16 reactivation assessment; instead, they

|          |         |         |
|----------|---------|---------|
| B:OMARIN | 270-301 | Page 61 |
|----------|---------|---------|

will be tested for hepatitis B and hepatitis C reactivation at the time points listed in [Table 9.1.5](#).

A liver ultrasound and liver function testing at Screening will identify any significant hepatic dysfunction.

Liver function tests will be monitored on a regular basis; at each time point, the following LFTs should be assessed:

**Table 9.7.8.3.1: Liver Function Tests**

| Liver Function Tests |                  |                 |     |
|----------------------|------------------|-----------------|-----|
| Alkaline Phosphatase | AST (SGOT)       | Total Bilirubin | LDH |
| ALT (SGPT)           | Direct Bilirubin | GGT             |     |

ALT, alanine aminotransferase; AST, aspartate aminotransferase; GGT, gamma-glutamyltransferase; LDH, lactate dehydrogenase; SGOT, serum glutamic-oxaloacetic transaminase; SGPT, serum glutamic-pyruvic transaminase

Elevated ALT levels (above the upper limit of normal range) should be evaluated according to the following plan:



|                |         |         |
|----------------|---------|---------|
| <b>BOMARIN</b> | 270-301 | Page 62 |
|----------------|---------|---------|

**Table 9.7.8.3.2: Evaluation of ALT Elevations**

| <b>ALT Level</b>        | <b>Work-Up</b>   |
|-------------------------|--|
| Above ULN and <1.5x ULN | <ul style="list-style-type: none"> <li>Continue to monitor LFTs and FVIII per protocol (repeat within 7 days if next protocol scheduled visit is &gt;7 days from the time of the reported ALT elevation)</li> <li>Consider evaluation to rule out alternative etiology (eg, concomitant medications, viral or autoimmune hepatitis, alcohol use, recreational drug use, special diets, strenuous exercise, prior and/or concurrent illnesses, exposure to environmental and/or industrial chemicals, etc.) (refer to <a href="#">Table 9.7.8.3.3</a>)</li> </ul>   |
| 1.5 - <3x ULN           | <ul style="list-style-type: none"> <li>Repeat LFTs and FVIII within 72 hours</li> <li>Continue to monitor LFTs weekly until ALT is stable or improving</li> <li>Evaluate and rule out alternative etiologies (as above)</li> <li>Consult with Medical Monitor</li> </ul>   |
| ≥3x ULN                 | <ul style="list-style-type: none"> <li>Consult with Medical Monitor</li> <li>If ≥3x ULN in 2 consecutive assessments within 48 hours, start oral corticosteroids (refer to <a href="#">Section 9.4.8.2</a>)</li> <li>Repeat LFTs and FVIII within 48 hours</li> <li>Evaluate and rule out alternative etiologies (as above)</li> <li>Obtain other possibly relevant laboratory evaluations (albumin, PT/INR, CRP, etc.)</li> <li>Obtain complete blood count with differential to assess for eosinophilia</li> <li>Obtain PBMC to evaluate potential immune response (prior to starting oral corticosteroids)</li> <li>If no improvement in 14 days, consider gastroenterology and/or hepatology consult, abdominal workup, imaging (including MRI or ultrasound), and/or liver biopsy as appropriate</li> </ul> |

When ruling out alternative viral or autoimmune hepatitis as part of the elevated ALT workup, the following tests should be performed:

**Table 9.7.8.3.3: Viral and Autoimmune Hepatitis Testing**

| <b>Viral Hepatitis Workup Testing</b> | <b>Autoimmune Hepatitis Workup Testing</b> |
|---------------------------------------|--|
| Hepatitis A                           | Smooth muscle antibody                     |
| Hepatitis B                           | Mitochondrial antibody                     |
| Hepatitis C                           | Liver/kidney microsomal antibodies         |
| Cytomegalovirus (CMV)                 | Antinuclear antibody (ANA) HEP-2           |
| Epstein-Barr virus (EBV)              |  |
| Herpes simplex virus (HSV) 1 & 2      |  |

#### **9.7.8.4 HIV Testing**

HIV testing will be performed at Screening. Subjects with documented negative results within the last 30 days prior to screening do not need to be retested.

#### **9.7.8.5 Vital Signs, Physical Examinations and Other Observations Related to Safety**

Vital signs will include seated systolic and diastolic blood pressure, heart rate, respiration rate, and temperature. Any clinically significant change in vital signs will be recorded as an AE.

Systolic blood pressure, diastolic blood pressure, heart rate, respiration rate, and temperature will be assessed at Screening, Baseline, and at the beginning of each visit during the Post-Infusion Follow-Up and Long-Term Follow-Up periods. On the day of the BMN 270 Infusion, vital signs will be monitored prior to infusion, during the infusion every 15 minutes ( $\pm 5$  minutes), following the infusion hourly ( $\pm 5$  minutes) for at least 8 hours during the subject's stay in the clinic. Any abnormal vital sign assessments should be repeated, and both values should be recorded in the eCRF.

A complete physical examination is necessary during Screening/Baseline, at Week 26 and 52 and every 52 weeks thereafter; at other visits, brief physical examinations may be performed at the discretion of the Investigator based on the subject's clinical condition. Particular attention should be given to signs of bleeding, as well as assessing possible hemarthroses.

A complete physical examination will include general appearance (head, eyes, ears, nose, and throat), cardiovascular, dermatologic, lymphatic, respiratory, gastrointestinal, genitourinary, musculoskeletal, and neurologic systems.

A brief physical examination will include general appearance, cardiovascular, respiratory, neurologic, and gastrointestinal assessments.

Height will be recorded at Screening only. Weight will be recorded at Screening and then every 4 weeks thereafter through Week 52, and every 6 months during Years 2-5.

### 9.7.8.6 Vector Shedding

During the Post-Infusion Follow-Up period, subjects will undergo testing of various bodily samples to look for evidence of vector shedding for possible viral transmission. Bodily fluids will be tested by PCR. Fluids tested will include:

- Blood
- Saliva
- Semen
- Urine
- Stool

Vector shedding will also be extensively studied in the present clinical trial, weekly until Week 4 and then every 4 weeks between Weeks 4-52 until at least 3 consecutive negative results are obtained. Testing of semen will continue at least through Week 12, even if 3 consecutive negative results have been recorded in that compartment prior to that timepoint. Subjects who have not had 3 consecutive negative semen samples by Week 52 should continue to have PCR testing in semen every 4 weeks until 3 consecutive negative samples are documented (or upon consultation between the Investigator and Medical Monitor).

Samples may be fractionated prior to shedding analysis in order to better characterize the presence, structure, and location of vector DNA and/or vector capsid within each matrix. If needed, the fractionation will be performed with samples collected specifically for shedding analysis (saliva, blood, semen, urine, faeces). Alternatively, the vector DNA characterization during shedding analysis may utilize already fractionated exploratory samples obtained from the above biofluids, such as exploratory plasma samples, exploratory PBMC samples, and red blood cells recovered during PBMC/plasma isolations.

Fractionation of semen to collect purified sperm separately from non-sperm cells may be performed in parallel at any visit where semen samples are collected. The shedding analysis of a fractionated semen sample will only be performed if vector DNA was detected in the whole semen sample for the same visit. Fractionation of semen during shedding analysis may be stopped if purified sperm tested positive for vector DNA on at least three visits, or if purified sperm tested negative for vector DNA on at least three consecutive visits.

Contraception use may need to be extended beyond 26 weeks in individual subjects based on observed vector shedding in semen. After 26 weeks, subjects may stop contraception use only if they have had 3 consecutive negative semen samples.

Details for sample collection and storage are provided in the Laboratory Manual.

## 10 REPORTING ADVERSE EVENTS

### 10.1 Safety Parameters and Definitions

Safety assessments will consist of monitoring and recording protocol-defined AEs and SAEs; measurement of protocol-specified hematology, clinical chemistry, and urinalysis variables; measurement of protocol-specified vital signs; and other protocol-defined events of special interest that are deemed critical to the safety evaluation of the study drug.

#### 10.1.1 Adverse Events

For this protocol, an adverse event (AE) is any untoward medical occurrence in a subject, temporally associated with the use of study intervention, whether or not considered related to the study intervention.

An AE can therefore be any unfavorable and unintended sign (including an abnormal laboratory finding), symptom, or disease (new or exacerbated) temporally associated with the use of study intervention.

Events meeting the AE definition include:

- Exacerbation of a chronic or intermittent pre-existing condition including either an increase in frequency and/or intensity of the condition.
- New conditions detected or diagnosed after study intervention administration even though it may have been present before the start of the study.
- Signs, symptoms, or the clinical sequelae of a suspected drug-drug interaction.

Events not meeting the AE definition include:

- Any clinically significant abnormal laboratory findings or other abnormal safety assessments which are associated with the underlying disease, unless judged by the investigator to be more severe than expected for the participant's condition.
- The disease/disorder being studied or expected progression, signs, or symptoms of the disease/disorder being studied, unless more severe than expected for the participant's condition.
- Medical or surgical procedure (eg, endoscopy, appendectomy): the condition that leads to the procedure is the AE.
- Situations in which an untoward medical occurrence did not occur (social and/or convenience admission to a hospital).
- Anticipated day-to-day fluctuations of pre-existing disease(s) or condition(s) present or detected at the start of the study that do not worsen.

### 10.1.1.1 Bleeding and Suspected Bleeding Events

All bleeding events and suspected bleeding events, regardless of the need for exogenous FVIII therapy as treatment, should be captured in subject diaries and recorded on the designated bleeding eCRF. Bleeding events and suspected bleeding events should not be reported as adverse events, with the following exception:

- All bleeding events and suspected bleeding events which meet one or more of the criteria for being serious (refer to Section 10.2) should be reported as serious adverse events (whether or not they are bleeding events that are normal sequelae of hemophilia, and whether or not they required exogenous FVIII as treatment).

## 10.2 Serious Adverse Events

A serious adverse event (SAE) is any untoward medical occurrence that, at any dose:

- Results in death
- Is life-threatening

*Note: Life-threatening refers to an event in which the subject was at risk of death at the time of the event. It does not refer to an event, which hypothetically might have caused death, if it were more severe.*

- Requires inpatient hospitalization or prolongation of existing hospitalization

Note: In general, hospitalization signifies that the subject has been detained (usually involving at least an overnight stay) at the hospital or emergency ward for observation and/or treatment that would not have been appropriate in the physician's office or outpatient setting. Complications that occur during hospitalization are AEs. If a complication prolongs hospitalization, the event is serious.

Hospitalization for elective treatment of a pre-existing condition that did not worsen from baseline is not considered an AE.

- Results in persistent or significant disability or incapacity
- Is a congenital anomaly or birth defect in the child or fetus of a subject exposed to IP prior to conception or during pregnancy
- Is an important medical event or reaction – that, based on medical judgment, may jeopardize the subject or require medical/surgical intervention to prevent one of the other outcomes listed above (eg, anaphylaxis)

### 10.2.1 Events of Special Interest (EOSI)

The following EOSI need to be reported to the Sponsor within 24 hours of site awareness, irrespective of seriousness, severity or causality:

- Elevation of ALT > 1.5x ULN, regardless of whether that elevation triggers an initiation or modification of oral corticosteroid treatment
- Thromboembolic event

### **10.3 Methods and Timing for Capturing and Assessing Safety Parameters**

#### **10.3.1 Adverse Event Reporting Period**

The study AE reporting period is as follows: After informed consent but prior to initiation of study drug, only SAEs associated with any protocol-imposed interventions will be collected. After informed consent is obtained and following infusion of study drug, the reporting period for all non-serious AEs and SAEs begins and continues for approximately 5 years or until study discontinuation/termination, whichever is longer. The criteria for determining, and the reporting of SAEs is provided in Section 10.2.

#### **10.3.2 Eliciting Adverse Events**

Care will be taken not to introduce bias when detecting AEs and/or SAEs. Open-ended and non-leading verbal questioning of the subject is the preferred method to inquire about AE occurrences. The Investigator will record all relevant AE/SAE/EOSI information in the subject's medical record and AE Case Report Form (eCRF).

#### **10.3.3 Assessment of Seriousness, Severity, and Causality**

The Investigator responsible for the care of the subject or medically qualified designee will assess AEs for severity, relationship to study drug, and seriousness (refer to Section 10.2 for SAE definitions). These assessments must be made by a study clinician with the training and authority to make a diagnosis (eg, MD/DO, physician's assistant, nurse practitioner, or DDS).

##### **10.3.3.1 Seriousness**

The Investigator will assess if an AE should be classified as "serious" based on the seriousness criteria enumerated in Section 10.2. Seriousness serves as a guide for defining regulatory reporting obligations.

##### **10.3.3.2 Severity**

Severity (as in mild, moderate, or severe headache) is not equivalent to seriousness, which is based on subject/event outcome or action criteria usually associated with events that pose a threat to a subject's life or functioning. The Investigator will determine the severity of each AE, SAE and EOSI using the NCI CTCAE v4.03. Adverse events that do not have a

|          |         |         |
|----------|---------|---------|
| B:OMARIN | 270-301 | Page 68 |
|----------|---------|---------|

corresponding CTCAE term will be assessed according to the general guidelines for grading used in the CTCAE v4.03 as stated in [Table 10.3.3.2.1](#).

**Table 10.3.3.2.1: Adverse Event Grading (Severity) Scale**

| Grade | Description  |   |
|-------|--|---|
| 1     | Mild: asymptomatic or mild symptoms; clinical or diagnostic observations only; intervention not indicated  |   |
| 2     | Moderate: minimal, local or noninvasive intervention indicated; limiting age-appropriate instrumental activities of daily living (ADL) <sup>a</sup>                                |   |
| 3     | Severe or medically significant but not immediately life-threatening: hospitalization or prolongation of hospitalization indicated; disabling; limiting self-care ADL <sup>b</sup> |   |
| 4     | Life threatening consequences; urgent intervention indicated   | Grade 4 and 5 AEs should always be reported as SAEs |
| 5     | Death related to AE  |   |

<sup>a</sup> Instrumental ADL refer to the following examples: preparing meals, shopping for groceries or clothes, using the telephone, managing money.

<sup>b</sup> Self-care ADL refer to the following examples: bathing, dressing and undressing, feeding oneself, using the toilet, taking medications, not bedridden.

### 10.3.3.3 Causality

The Investigator will determine the relationship of an AE to the study drug and will record it on the source documents and AE eCRF. To ensure consistency of causality assessments, Investigators should apply the guidance in [Table 10.3.3.3.1](#).

**Table 10.3.3.3.1: Causality Attribution Guidance**

| <b>Relationship</b> | <b>Description</b>   |
|---------------------|--|
| Not Related         | <ul style="list-style-type: none"> <li>• Exposure to the IP has not occurred</li> </ul> <p style="text-align: center;"><b>OR</b></p> <ul style="list-style-type: none"> <li>• The administration of the IP and the occurrence of the AE are not reasonably related in time</li> </ul> <p style="text-align: center;"><b>OR</b></p> <ul style="list-style-type: none"> <li>• The AE is considered likely to be related to an etiology other than the use of the IP; that is, there are no facts, evidence, or arguments to suggest a causal relationship to the IP.</li> </ul>  |
| Related             | <ul style="list-style-type: none"> <li>• The administration of the IP and the occurrence of the AE are reasonably related in time</li> </ul> <p style="text-align: center;"><b><u>AND</u></b></p> <ul style="list-style-type: none"> <li>• The AE could possibly be explained by factors or causes other than exposure to the IP</li> </ul> <p style="text-align: center;"><b><u>OR</u></b></p> <ul style="list-style-type: none"> <li>• The administration of IP and the occurrence of the AE are reasonably related in time</li> </ul> <p style="text-align: center;"><b><u>AND</u></b></p> <ul style="list-style-type: none"> <li>• The AE is more likely explained by exposure to the IP than by other factors or causes.</li> </ul> |

Factors suggestive of a causal relationship could include (but are not limited to):

- Plausible temporal relationship
- Absence of alternative explanations
- Rarity of event in a given patient or disease state
- Absence of event prior to study drug exposure
- Consistency with study product pharmacology
- Known relationship to underlying mechanism of study drug action
- Similarity to adverse reactions seen with related drug products
- Abatement of AE with discontinuation of study drug, and/or recurrence of AE with reintroduction of study drug



The Investigator's assessment of causality for individual AE reports is part of the study documentation process. Regardless of the Investigator's assessment of causality for individual AE reports, the Sponsor will promptly evaluate all reported SAEs against cumulative product experience to identify and expeditiously communicate possible new safety findings to Investigators and applicable regulatory authorities.

## **10.4 Procedures for Recording Adverse Events**

### **10.4.1 Recording Adverse Events on a eCRF**

Investigators should use precise medical terminology when recording AEs or SAEs on the AE eCRF. Avoid colloquialisms and abbreviations.

Record only one diagnosis, sign, or symptom per event field on the AE eCRF (eg, nausea and vomiting should not be recorded in the same entry, but as 2 separate entries).

In order to classify AEs and diseases, preferred terms will be assigned by the Sponsor to the original terms entered on the AE eCRF, using MedDRA (Medical Dictionary for Regulatory Activities) terminology.

#### **10.4.1.1 Diagnosis versus Signs and Symptoms**

The Investigator will attempt to establish a diagnosis of the event based on signs, symptoms, and/or other clinical information. Whenever possible, the diagnosis (not the individual signs/symptoms) will be documented as the AE/SAE. Using accepted medical terminology, enter the diagnosis (if known). If not known, enter sign(s) and/or symptom(s). If a diagnosis subsequently becomes available, then this diagnosis should be entered on the AE (or SAE, as appropriate) eCRF, replacing the original entries where appropriate.

#### **10.4.1.2 Adverse Events Occurring Secondary to Other Events**

In general, AEs occurring secondary to other events (eg, cascade events) should be identified by their primary cause. For example, if severe diarrhea is known to have resulted in dehydration, it is sufficient to record only diarrhea as an AE or SAE on the AE eCRF. However, medically important events that may be linked and/or separated in time should be recorded as independent events on the AE eCRF. For example, if severe hemorrhage leads to renal failure, both events should be recorded separately on the AE eCRF.

#### **10.4.1.3 Persistent or Recurrent Adverse Events**

A persistent AE (duration of adverse event > 7 days) is one that extends continuously, without resolution, between subject evaluation time points. Events that change in severity

necessitate the recording of an additional AE. AEs that do not have a change in severity should be recorded only once on the eCRF.

A recurrent AE is one that occurs and resolves between subject evaluation time points, but then subsequently recurs. All recurrences of the AE should be recorded on the AE eCRF. For example, if a subject has an adverse event of ALT increased that subsequently resolves, but the subject's ALT increases again, that should be reported as two adverse events – the initial ALT increase, and the second ALT increase.

#### 10.4.1.4 Abnormal Laboratory Values

Laboratory test results will be recorded on the laboratory results pages of the eCRF, or appear on electronically produced laboratory reports submitted directly from the central laboratory, if applicable.

Any laboratory result abnormality fulfilling the criteria for a SAE or EOSI should be reported as such, and recorded in the AE eCRF.

Any laboratory result abnormality of CTCAE Grade 4 or 5 should be recorded as an SAE in the AE eCRF.

A clinical laboratory abnormality is considered clinically significant and should be documented as an AE if not refuted by a repeat test to confirm the abnormality and **any** one or more of the following conditions is met:

- Accompanied by clinical symptoms
- Requiring a change in concomitant therapy (eg, addition of, interruption of, discontinuation of, or any other change in a concomitant medication, therapy or treatment).
- The abnormality suggests a disease and/or organ toxicity
- The abnormality is of a degree that requires active management (eg, change of dose, discontinuation of study drug, more frequent follow-up assessments, further diagnostic investigation, etc.)

**This applies to** any protocol and non-protocol specified safety and efficacy laboratory result from tests performed after the first dose of study medication that falls outside the laboratory reference range and meets the clinical significance criteria.

**This does not apply to** any abnormal laboratory result that falls outside the laboratory reference range but that does not meet the clinical significance criteria (these will be analyzed and reported as laboratory abnormalities), those that are considered AEs of the type

explicitly exempted by the protocol, or those which are a result of an AE that has already been reported.

For purposes of this study, laboratory tests showing a decreased level of FVIII activity should not be reported as adverse events unless there is an impact to clinical outcomes (eg, increased rate of bleeding, worsening of joint disease).

#### **10.4.1.5 Pre-existing Conditions**

A pre-existing condition is one that is present prior to administration of BMN 270. Such conditions should be recorded as medical history on the appropriate eCRF.

A pre-existing condition should be recorded as an AE or SAE during the study **only** if the frequency, intensity, or character of the condition worsens during the study period. It is important to convey the concept that a pre-existing condition has changed by including applicable language in the verbatim description of the event (eg, *more frequent* headaches).

#### **10.4.1.6 General Physical Examination Findings**

At screening, any clinically significant abnormality should be recorded as a pre-existing condition (refer to Section 10.4.1.5). During the study, any new clinically significant findings and/or abnormalities discovered on physical examination that meet the definition of an AE (or an SAE) must be recorded and documented as an AE or SAE on the AE eCRF.

#### **10.4.1.7 Hospitalization, Prolonged Hospitalization, or Surgery**

Any AE that results in hospitalization or prolonged hospitalization should be documented and reported as an SAE unless specifically instructed otherwise in this protocol (refer to Section 10.2).

There are some hospitalization scenarios that do not require reporting as an SAE when there is no occurrence of an AE. These scenarios include planned hospitalizations or prolonged hospitalizations to:

- Perform a protocol-mandated efficacy measurement
- Undergo a diagnostic or elective surgical procedure for a pre-existing medical condition that has not worsened
- Insert an in-dwelling IV catheter (such as a Port-a-Cath or other brand, if applicable) for administration of study drug or FVIII replacement therapy
- Receive scheduled therapy (study drug or otherwise) for the study indication

#### **10.4.1.8 Deaths**

All deaths that occur during the AE reporting period (refer to Section 10.3.1), regardless of attribution, will be recorded on the AE eCRF and expeditiously reported to the Sponsor as an SAE.

When recording a death, the event or condition that caused or contributed to the fatal outcome should be recorded as the single medical concept on the eCRF. If the cause of death is unknown and cannot be ascertained at the time of reporting, record “Unexplained Death” or “Death of Unknown Cause” on the AE eCRF.

#### **10.4.1.9 Pregnancy**

Although not an AE per se, pregnancy in the partner of a subject taking trial medication should be reported expeditiously to the Sponsor to facilitate outcome monitoring by the Sponsor. Pregnancy in partner should be reported during the period up to 5 years after viral infusion.

Pregnancy in a partner should be reported within 24 hours of the site becoming aware of the pregnancy by entering the information on the Pregnancy eCRF and submitting to BPV within 24 hours of the site becoming aware of the event. The Investigator must make every effort to follow the subject’s partner (with that partner’s consent) through resolution of the pregnancy (delivery or termination) and to report the resolution on the Pregnancy Follow-up eCRF. In the event of pregnancy in the partner of a study subject, the Investigator should make every reasonable attempt to obtain the woman’s consent for release of protected health information.

Abortion, whether therapeutic or spontaneous, should always be classified as an SAE (as the Sponsor considers these to be medically significant), recorded on the AE eCRF, and expeditiously reported to the Sponsor as an SAE.

### **10.5 Reporting Requirements**

#### **10.5.1 Expedited Reporting Requirements**

All SAEs and EOSI that occur during the course of the AE Reporting Period (refer to Section 10.3.1), whether or not considered related to study drug, must be reported by entering the information in the AE eCRF and submitting to BPV within 24 hours of the site becoming aware of the event. Investigators should not wait to collect information that fully documents the event before notifying BPV of an SAE. BioMarin may be required to report certain SAEs to regulatory authorities within 7 calendar days of being notified about the event; therefore, it is important that Investigators submit any information requested by BioMarin as soon as it becomes available.

The Sponsor is responsible for identifying, preparing and reporting all SUSARs to the relevant competent authorities, ethics committees and Investigators in accordance with the requirements identified in the Clinical Trials Regulations.

If the EDC is unavailable, all SAEs should be reported to BPV by completing the SAE Report Form and faxing or emailing the completed form to BPV within 24 hours of the site becoming aware of the event. Once the EDC is available, the information should be entered in the AE eCRF.

### **10.5.2 Institutional Review Board or Independent Ethics Committee Reporting Requirements**

Reporting of SAEs to the Independent Ethics Committee (IEC) or Institutional Review Board (IRB) will be done in compliance with the standard operating procedures and policies of the IEC/IRB and with applicable regulatory requirements. Adequate documentation must be obtained by BioMarin showing that the IEC/IRB was properly and promptly notified as required.

### **10.6 Follow-up of Subjects after Adverse Events**

After the initial AE/SAE/EOSI report, the Investigator is required to proactively follow each participant at subsequent visits/contacts. All AEs/SAEs/EOSI will be followed until resolution, stabilization, the event is otherwise explained, or the participant is lost to follow-up. Resolution of AEs/SAEs/EOSI (with dates) should be documented on the AE eCRF and submitted to BioMarin Pharmacovigilance and in the subject's medical record to facilitate source data verification.

For some SAEs and EOSI, the Sponsor may follow up by telephone, fax, electronic mail, and/or a monitoring visit to obtain additional case details (eg, hospital discharge summary, consultant report, or autopsy report) deemed necessary to appropriately evaluate the SAE or EOSI report.

### **10.7 Post-Study Adverse Events**

At the last scheduled visit, the Investigator should instruct each subject to report, to the Investigator and/or to BPV directly, any subsequent SAEs that the subject's personal physician(s) believes might be related to prior study drug.

The Investigator should notify the study Sponsor of any death or SAE occurring at any time after a subject has discontinued or terminated study participation, if the Investigator believes that the death or SAE may have been related to prior study drug. The Sponsor should also be notified if the Investigator should become aware of the development of cancer or of a

congenital anomaly in a subsequently conceived offspring of a subject that participated in this study.

### **10.8 Urgent Safety Measures**

The regulations governing clinical trials state that the Sponsor and Investigator are required to take appropriate urgent safety measures to protect subjects against any immediate hazards that may affect the safety of subjects, and that the appropriate regulatory bodies should be notified according to their respective regulations. According to the European Union (EU) Clinical Trial Directive 2001/20/EC, "...in the light of the circumstances, notably the occurrence of any new event relating to the conduct of the trial or the development of the investigational medicinal product where that new event is likely to affect the safety of the patients, the Sponsor and the Investigator shall take appropriate urgent safety measures to protect the patients against any immediate hazard. The Sponsor shall forthwith inform the competent authorities of those new events and the measures taken and shall ensure that the IRB/IEC/REB is notified at the same time."

The reporting period for these events which may require the implementation of urgent safety measures is the period from the time of signing of the ICF through the completion of the last study visit or at the Early Termination Visit (ETV). Investigators are required to report any events which may require the implementation of urgent safety measures to BioMarin within 24 hours.

Examples of situations that may require urgent safety measures include discovery of the following:

- Lack of study scientific value, or detrimental study conduct or management
- Discovery that the quality or safety of the IP does not meet established safety requirements

### **10.9 BioMarin Pharmacovigilance Contact Information**

Contact information for BioMarin Pharmacovigilance is as follows:

BioMarin Pharmaceutical Inc.

Address 105 Digital Drive  
Novato, CA 94949

Phone: +1 (415) 506-6179

Fax: +1 (415) 532-3144

E-mail: [drugsafety@bmrn.com](mailto:drugsafety@bmrn.com)

**BOMARIN**

270-301

Page 76

The Investigator is encouraged to discuss with the Medical Monitor any AEs for which the issue of seriousness is unclear or questioned. Contact information for the Medical Monitor is as follows:

Name: **PI** [REDACTED], MD, MPhil

Address: 105 Digital Drive  
Novato, CA 94949 USA

Phone: **PI** [REDACTED]

E-mail: **PI** [REDACTED]

## **11 APPROPRIATENESS OF MEASUREMENTS**

The measures of efficacy to be used in this study are standard, ie, widely used and generally recognized as reliable, accurate, and relevant (able to discriminate between effective and ineffective agents). The measures of safety used in this study are routine clinical and laboratory procedures.

The chromogenic FVIII assay and the one-stage clot FVIII assay are both validated and utilize CE marked reagents. The exploratory FVIII activity assay will be used for exploratory purposes only.



## 12 STUDY PROCEDURES

### 12.1 Prestudy

An ICF must be signed and dated by the patient, the Investigator or designee and witness (if required) before any study-related procedures are performed.

### 12.2 Screening Visit

Screening assessments should be performed within 28 days of BMN 270 infusion (and must be performed within 42 days prior to BMN 270 infusion), while baseline assessments will take place within 7 days prior to BMN 270 infusion (Day 1). Should the screening visit occur within 30 days of the drug infusion, physical examination, vital signs, blood chemistry, LFTs, hematology, urine tests, and coagulation tests do not need to be repeated at Baseline.

The following procedures will be performed during the Screening Period:

- Demographics (age, sex, race, ethnicity)
- Full medical history, including hemophilia A history, Hepatitis B, Hepatitis C, and HIV.
- Complete Physical Examination
- Height and weight
- Vital Signs (systolic and diastolic blood pressure, heart rate, respiration rate, and temperature)
- Assessment of Adverse Events and Concomitant Medications
- Documentation of bleeding episodes and FVIII usage (by either subject or clinical information) for the previous 12 months
  - Further information on details to be included in documentation of previous bleeding episodes and FVIII usage, refer to the Study Reference Manual.
- Distribution of subject diaries and training in diary completion
- Electrocardiogram
- Liver Ultrasound
- Samples for hFVIII Assays
  - Baseline FVIII activity – chromogenic FVIII assay
  - Baseline FVIII activity level – one-stage clot FVIII assay
  - hFVIII coagulation activity exploratory assay (collected but not tested prior to enrollment)

|         |         |         |
|---------|---------|---------|
| BOMARIN | 270-301 | Page 79 |
|---------|---------|---------|

- hFVIII inhibitors (Bethesda assay with Nijmegen modification)
- hFVIII total antibody assay (collected but not tested prior to enrollment)
- hFVIII protein assay (collected but not tested prior to enrollment)
- Blood sample for AAV5 total antibody (TAb) assay
- Screen for Hepatitis B, Hepatitis C, and HIV if required (subjects with documented negative results 30 days prior to informed consent being obtained do not need to be retested)
- Blood chemistry, hematology, and coagulation tests (refer to [Table 9.7.8.2.1](#))
- Urine Tests (refer to [Table 9.7.8.2.1](#))
- Liver Function Tests (refer to [Table 9.7.8.3.1](#))
- Von Willebrand Factor Antigen (VWF:Ag)
- Blood samples for Biomarker testing (including HLA genotyping, FVIII genotyping status, TNF $\alpha$  and IL10a single nucleotide polymorphisms)

### 12.2.1 “Smart Rescreening” Visit

Subjects who undergo smart rescreening must complete the rescreening assessments and receive the infusion within 90 days of signing the original consent. Subjects who do not complete dosing within 90 days will be required to re-consent and undergo all screening procedures. Subjects may not undergo smart rescreening more than once.

If a patient has to be screened again because the original assessments have fallen out of the 28 + 14 day period allowed for Screening (refer to Section [12.2](#)), then only the following assessments need to be performed (rather than the full list indicated in Section [12.2](#)) for the patient to be successfully re-screened for the study:

- Vital signs
- Assessment of Adverse Events and Concomitant Medications
- Documentation of bleeding episodes and FVIII usage (by either subject or clinical information)
- hFVIII Assays (only the hFVIII inhibitor level (Bethesda assay with Nijmegen modification))
- Blood sample for AAV5 Total Antibody assay
- Blood chemistry, hematology, and coagulation tests (refer to [Table 9.7.8.2.1](#))
- Urine Tests (refer to [Table 9.7.8.2.1](#))
- Liver Function Tests (refer to [Table 9.7.8.3.1](#))

### 12.3 Baseline Visit

Baseline values will be recorded from 1 to 7 days prior to the treatment visit. The following procedures will be performed during the Baseline Period:

- Brief physical examination
- Vital signs
- Assessment of Adverse Events and Concomitant Medications
- Documentation of bleeding episodes and FVIII usage (by either subject or clinical information)
- Blood sample for AAV5 TI assay
- Blood sample for AAV5 TAb assay
- Blood chemistry, hematology, and coagulation tests (refer to [Table 9.7.8.2.1](#))
- Urine Tests (refer to [Table 9.7.8.2.1](#))
- Liver Function Tests (refer to [Table 9.7.8.3.1](#))
- Samples for hFVIII Assays
  - Baseline FVIII activity – chromogenic FVIII assay
  - Baseline FVIII activity level – one-stage clot FVIII assay
  - hFVIII coagulation activity exploratory assay (collected but not tested prior to enrollment)
  - hFVIII inhibitors (Bethesda assay with Nijmegen modification)
  - hFVIII total antibody assay (collected but not tested prior to enrollment)
  - hFVIII protein assay (collected but not tested prior to enrollment)
- PBMC collection for CTL baseline
- Direct Thrombin test
- TGA Assay
- PCR of vector DNA in blood, saliva, urine, semen, and stools
- Exploratory biomarker assessments
- Haemo-QoL-A QoL assessment
- EQ-5D-5L
- Hemophilia Activities List (HAL)

|         |         |         |
|---------|---------|---------|
| BOMARIN | 270-301 | Page 81 |
|---------|---------|---------|

- Work Productivity and Activity Impairment plus Classroom Impairment Questions: Hemophilia Specific (WPAI+CIQ:HS) questionnaire

#### 12.4 Treatment Visit/BMN 270 Infusion Visit (Day 1)

There will be one treatment visit for each subject. Subjects will remain in the clinic for at least 8 hours for the BMN 270 Infusion Visit. The following procedures will be performed during the BMN 270 Infusion Visit:

- Brief physical examination
- Assessment of Adverse Events and Concomitant Medications
- AAV5 TAb Assay (sample collected pre-infusion for analysis)
- BMN 270 Infusion
- Vital Signs
  - Vital signs will be recorded prior to BMN 270 infusion and then every 15 minutes ( $\pm 5$  minutes) during BMN 270 infusion. Following infusion, vital signs will be monitored every 1 hour ( $\pm 5$  minutes) for at least 8 hours during the subject's stay in the clinic.
- PCR of vector DNA in blood, saliva, urine, semen, and stools
  - Collection of samples for PCR testing should occur at least 2 hours after the BMN 270 infusion has been completed

#### 12.5 BMN 270 Infusion Follow-Up Visits – Weeks 1-26

After BMN 270 has been infused, subjects will return to the study site every week ( $\pm 48$  hours) during Weeks 1-26, when the following procedures will be completed:

##### 12.5.1 Once per week (Weeks 1 through 26)

The following procedures will be performed at one visit per week from Weeks 1 through 20:

- Brief physical examination (complete physical examination at Week 26)
- Assessment of Adverse Events and Concomitant Medications (including review of subject diary for bleeding and FVIII use)
- Vital Signs
- Liver Function Tests (refer to [Table 9.7.8.3.1](#))
  - LFTs may be monitored more or less frequently (and in particular when ALT values are  $>1.5x$  ULN) based on discussion between the Medical Monitor and the Investigator and review of subject data.
- Samples for FVIII Assays

- FVIII activity level (chromogenic FVIII assay)
- FVIII activity level (one-stage clot FVIII assay)
- FVIII coagulation activity exploratory assay
- Bethesda assay (with Nijmegen modification) for hFVIII inhibitor level
- FVIII protein assay

### 12.5.2 Week 1 – Day 4

On Day 4 of Week 1, the following procedures will be performed:

- PCR of vector DNA in blood, saliva, urine, semen, and stools
- Liver Function Tests (refer to [Table 9.7.8.3.1](#))

### 12.5.3 Week 1 – Day 8

On Day 8, the following procedures will be performed, in addition to the weekly assessments required in Section [12.5.1](#):

- PCR of vector DNA in blood, saliva, urine, semen, and stools

### 12.5.4 Every 2 Weeks (Week 2, 4, 6, 8, 10, 12, 14, 16, 18, 20, 22, 24, and 26)

At Weeks 2, 4, 6, 8, 10, 12, 14, 16, 18, 20, 22, 24, and 26 the following procedure will be performed:

- PBMC collection

### 12.5.5 Weeks 2, 4, 10, 16, 22, and 26

At Weeks 2, 4, 10, 16, 22, and 26 the following procedure will be performed:

- Blood chemistry, hematology, and coagulation tests (refer to [Table 9.7.8.2.1](#))

### 12.5.6 Weeks 2, 3, 4, 6, 8, 12, 16, 20, 24, and 26

At Weeks 2, 3, 4, 6, 8, 12, 16, 20, 24, and 26, the following procedure will be performed:

- PCR of vector DNA in blood, saliva, urine, semen, and stools
  - Collection to occur until at least 3 consecutive negative results are obtained. Semen samples should continue to be collected and tested through Week 12, even if 3 consecutive negative results in that compartment have been recorded prior to that timepoint.

### 12.5.7 Weeks 4, 12, and 26

At Weeks 4, 12, and 26, the following procedure will be performed:

- Haemo-QoL-A QoL assessment
- EQ-5D-5L
- HAL
- WPAI+CIQ:HS

**12.5.8 Every 4 Weeks (Weeks 4, 8, 12, 16, 20, and 24) Plus Week 26**

At Weeks 4, 8, 12, 16, 20, 24, and 26, the following procedures will be performed:

- Weight (not performed at Week 26)
- FVIII antibody titer

**12.5.9 Every 8 Weeks (Weeks 8, 16, and 24)**

At Weeks 8, 16, and 24, the following procedures will be performed:

- AAV5 TAb assay
- AAV5 TI assay

**12.5.10 Weeks 6, 13, 16, 20, 24, and 26**

At Weeks 6, 13, 16, 20, 24, and 26, the following procedures will be performed:

- Exploratory biomarker assessments

**12.5.11 Weeks 12 and 26**

At Weeks 12 and 26, the following procedure will be performed:

- Urine Tests (refer to [Table 9.7.8.2.1](#))

**12.5.12 Week 13 and 26**

At Weeks 13 and 26, the following procedures will be performed:

- Direct Thrombin test
- VWF:Ag

**12.5.13 Week 16**

At Week 16, the following procedure will be performed:

- Test for Hepatitis B and Hepatitis C reactivation

- Subjects with evidence of prior exposure will be tested for hepatitis B and hepatitis C reactivation at Week 16. Subjects who receive therapeutic oral corticosteroids prior to Week 16 do not need to complete the Week 16 reactivation assessment; instead, they will be tested for hepatitis B and hepatitis C reactivation at the time points listed in [Table 9.1.5](#).

#### 12.5.14 Week 20, 24, and 26

At Week 20, 24, and 26, the following procedure will be performed:

- TGA Assay

#### 12.6 Post-Infusion Follow-Up – Weeks 27-52

During Weeks 27-36, subjects will return to the study site weekly ( $\pm$  48 hours). During Weeks 37-52, subjects will return to the study site every 2 weeks (Week 38, 40, 42, 44, 46, 48, 50, and 52) ( $\pm$  1 week). At these visits, the following procedures will be completed:

##### 12.6.1 Every Visit

At every visit (Weeks 27-36, 38, 40, 42, 44, 46, 48, 50, and 52), the following procedures will be performed:

- Physical examination
  - Brief physical examination should be performed at all weeks except Week 26, when a complete physical examination should be performed
- Assessment of Adverse Events and Concomitant Medications (including review of subject diary for bleeding and FVIII use)
- Vital Signs
- Liver Function Tests (refer to [Table 9.7.8.3.1](#))
  - LFTs may be monitored more or less frequently (and in particular when ALT values are  $>1.5x$  ULN) based on discussion between the Medical Monitor and the Investigator and review of subject data.
- FVIII Assays
  - FVIII activity level (chromogenic FVIII assay)
  - FVIII activity level (one-stage clot FVIII assay)
    - FVIII coagulation activity exploratory assay
    - Bethesda assay (with Nijmegen modification) for FVIII inhibitor level
    - FVIII protein assay

**12.6.2 Weeks 28, 30, 32, 34, 36, 44, and 52**

At Weeks 28, 30, 32, 34, 36, 44, and 52, the following procedure will be performed:

- PBMC collection

**12.6.3 Every 4 Weeks (Weeks 28, 32, 36, 40, 44, 48, 52)**

At Weeks 28, 32, 36, 40, 44, 48, and 52, the following procedure will be performed:

- Weight

**12.6.4 Weeks 32, 36, 44, and 52**

At Weeks 32, 36, 44, and 52, the following procedures will be performed:

- Blood chemistry, hematology, and coagulation tests (refer to [Table 9.7.8.2.1](#))
- FVIII antibody titer

**12.6.5 Weeks 32, 36, 40, 44, 48, and 52**

At Weeks 32, 36, 40, 44, 48, and 52, the following procedures will be performed:

- Exploratory biomarker assessments
- TGA Assay
- PCR of vector DNA in blood, saliva, urine, semen, and stools
  - Sample testing to occur until at least 3 consecutive negative sample results have been obtained. Subjects who have not had 3 consecutive negative semen samples by Week 52 should continue to have PCR testing of semen every 4 weeks until 3 consecutive negative samples are documented (or upon consultation between the Investigator and Medical Monitor).

**12.6.6 Week 32, 36, and 52**

At Week 32, 36, and 52, the following procedure will be performed:

- AAV5 TAb Assay
- AAV5 TI Assay

**12.6.7 Week 36 and 52**

At Weeks 36 and 52, the following procedures will be performed:

- Urine Tests (refer to [Table 9.7.8.2.1](#))
- Direct Thrombin test
- VWF:Ag



|   |         |         |
|---|---------|---------|
|  | 270-301 | Page 86 |
|---|---------|---------|

### 12.6.8 Week 52

At Week 52, the following procedures will be performed:

- Haemo-QoL-A QoL assessment
- EQ-5D-5L
- HAL
- WPAI+CIQ:HS

### 12.7 Post-Infusion Follow-Up – Years 2-5

During Years 2-5 of Post-Infusion Follow-up, subjects will be assessed every 3 months ( $\pm$  2 weeks). At these times, the following procedures will be completed:

#### 12.7.1 Every Visit

Every 3 months ( $\pm$  2 weeks), the following procedures will be performed:

- Physical examination
  - Complete physical examination will be performed every 52 weeks; brief physical examination may be performed at other visits.
- Assessment of Adverse Events and Concomitant Medications (including review of subject diary for bleeding and FVIII use)
- Vital Signs
- Liver Function Tests (refer to [Table 9.7.8.3.1](#))
  - LFTs may be monitored more or less frequently (and in particular when ALT values are  $>1.5x$  ULN) based on discussion between the Medical Monitor and the Investigator and review of subject data.
- FVIII Assays
  - FVIII activity level (chromogenic FVIII assay)
  - FVIII activity level (one-stage clot FVIII assay)
  - FVIII coagulation activity exploratory assay
  - Bethesda assay (with Nijmegen modification) for FVIII inhibitor level
  - FVIII protein assay
- AAV5 TAb Assay
- AAV5 TI Assay
- FVIII antibody titer

- Exploratory biomarker assessments
- PBMC collection
- VWF:Ag
- Direct Thrombin test
- TGA Assay

### 12.7.2 Every 4 Weeks (As Needed)

The following assessment should be performed every 4 weeks during Years 2-5, as needed:

- PCR of vector DNA in blood, saliva, urine, semen, and stools

Sample testing during Years 2-5 is not required if at least 3 consecutive samples are clear during the Post-Infusion Follow-Up period in Weeks 1-52. Subjects who have not had 3 consecutive negative semen samples by Week 52 should continue to have PCR testing of semen every 4 weeks until 3 consecutive negative samples are documented (or upon consultation between the Investigator and Medical Monitor).

### 12.7.3 Every Other Visit (Every 6 Months)

Every six months starting at the Week 78 visit (ie, 26 weeks after the Week 52 visit at the end of Year 1 of the Long-Term Follow-up period), the following procedure will be performed:

- Weight
- Blood chemistry, hematology, and coagulation tests (refer to [Table 9.7.8.2.1](#))
- Urine Tests (refer to [Table 9.7.8.2.1](#))
- Haemo-QoL-A QOL assessment
- EQ-5D-5L
- HAL
- WPAI+CIQ:HS

### 12.8 Early Termination Visit

The Early Termination visit will occur on the date the subject withdraws from the study, even if the date does not correspond to a protocol-specific visit.

If a subject leaves the study prior to the Week 260 visit, the subject will be asked to return to the study site and complete an Early Termination visit. At the Early Termination visit, as many of the following assessments as possible should be done:

- Physical examination
- Weight
- Assessment of Adverse Events and Concomitant Medications (including review of subject diary for bleeding and FVIII use)
- Vital Signs
- Blood chemistry, hematology, and coagulation tests (refer to [Table 9.7.8.2.1](#))
- Urine Tests (refer to [Table 9.7.8.2.1](#))
- Liver Function Tests (refer to [Table 9.7.8.3.1](#))
- FVIII Assays
  - FVIII activity level (chromogenic FVIII assay)
  - FVIII activity level (one-stage clot FVIII assay)
  - FVIII coagulation activity exploratory assay
  - Bethesda assay (with Nijmegen modification) for FVIII inhibitor level
  - FVIII protein assay
- AAV5 TAb Assay
- AAV5 TI Assay
- FVIII antibody titer
- Exploratory biomarker assessments
- PBMC collection
- VWF:Ag
- Direct Thrombin test
- TGA Assay
- PCR of vector DNA in blood, saliva, urine, semen, and stools
  - Sample testing at the ETV is not required if at least 3 consecutive samples were clear during the Post-Infusion Follow-Up period.
- Haemo-QoL-A QOL assessment
- EQ-5D-5L
- HAL
- WPAI+CIQ:HS

## 12.9 End of Study

The study will end after the last subject yet to complete the last Long-Term Follow-Up visit (Week 260) does so, has transferred to another BMN 270 study, is withdrawn from the study, or discontinues from the study. BioMarin reserves the right to discontinue the study any time for clinical or administrative reasons and to discontinue participation of an individual Investigator or site for clinical or administrative reasons, including, but not limited to, poor enrollment or noncompliance with procedures of the protocol or GCP. In addition, the study may be terminated if, in the opinion of BioMarin, the safety of the study subjects may be compromised.

### **13 DATA QUALITY ASSURANCE**

BioMarin personnel or designees will visit the study site prior to initiation of the study to review with the site personnel information about the IP, protocol and other regulatory document requirements, source document requirements, eCRFs, monitoring requirements, and procedures for reporting AEs, including SAEs.

At visits during and after the study, a CRA will monitor the site for compliance with regulatory documentation, with a focus on accurate and complete recording of data on eCRFs from source documents, adherence to protocol, randomization (if applicable), SAE reporting and drug accountability records.

Data quality control and analysis will be performed by BioMarin or a designee, based on a predefined analysis plan.

## 14 STATISTICAL METHODS AND DETERMINATION OF SAMPLE SIZE

### 14.1 Statistical and Analytical Plans

The statistical analysis plan (SAP) will provide additional details on the planned statistical analysis. Unless otherwise stated, all analyses will be performed using SAS.

#### 14.1.1 Interim Analyses

An interim analysis is planned when all treated subjects have completed the Week 26 visit.

The primary efficacy endpoint for the interim analysis is change in the median hFVIII activity during Weeks 22-26 post-BMN 270 infusion from baseline. The secondary efficacy endpoints for the interim analysis will be defined as follows:

- Change in the annualized utilization (IU/kg) of exogenous FVIII replacement therapy during Weeks 5-26 post-BMN 270 infusion from baseline.
- Change in the annualized number of bleeding episodes requiring exogenous FVIII replacement treatment during Weeks 5-26 post-BMN 270 infusion from baseline (tested first for non-inferiority using a margin of 3.5 and then for superiority).

The primary and secondary efficacy hypotheses for the interim analysis will be tested sequentially according to the same order as described for the final analysis.

The Bonferroni procedure will be used to adjust for multiplicity using  $\alpha=0.001$  at the interim analysis and  $\alpha=0.049$  at the final analysis.

However, regardless of the interim analysis results, the study will continue and the final analysis will be performed at Week 52.

The tertiary endpoints will be analyzed at the interim (Week 26) and final (Week 52) analyses, irrespective of the aforementioned hierarchical testing.

#### 14.1.2 Procedures for Accounting for Missing, Unused and Spurious Data

Because the completeness of the data affects the integrity and accuracy of the final study analysis, every effort should be made to ensure complete, accurate, and timely data collection and, therefore, avoid missing data.

Sensitivity analyses will be conducted to assess the impact of missing data on the primary efficacy endpoint analysis. Additional details regarding the handling of missing data will be provided in the SAP.

## 14.2 Primary and Secondary Efficacy Endpoints

For the primary efficacy endpoint at Week 52 (ie, the change in the median hFVIII activity during Weeks 48-52 post-BMN 270 infusion from baseline), a one-sample t-test will be used to test the null hypothesis that the change is 0 or less against the alternative hypothesis that the change is greater than 0.

For the first secondary efficacy endpoint at Week 52 (ie, the change in the annualized utilization (IU/kg) of exogenous FVIII replacement therapy during Weeks 5-52 post-BMN 270 infusion from baseline), a one-sample t-test will be performed to test the null hypothesis that the change is 0 or greater against the alternative hypothesis that the change is less than 0.

For the second secondary efficacy endpoint at Week 52 (ie, the change in the annualized number of bleeding episodes requiring exogenous FVIII replacement treatment during Weeks 5-52 post-BMN 270 infusion from baseline), a one-sample t-test will be performed to test for non-inferiority of BMN 270 against FVIII prophylaxis using a margin of 3.5. If non-inferiority is demonstrated, the test for superiority of BMN 270 against FVIII prophylaxis will be performed.

The primary and secondary efficacy hypotheses will be tested sequentially according to the order described above.

An interim analysis is planned when all 40 treated subjects have completed the Week 26 visit. The Bonferroni procedure will be used to adjust for multiplicity using  $\alpha=0.001$  at the interim analysis and  $\alpha=0.049$  at the final analysis.

However, regardless of the interim analysis results, the study will continue and the final analysis will be performed at Week 52.

The tertiary endpoints will be analyzed at the interim (Week 26) and final (Week 52) analyses, irrespective of the aforementioned hierarchical testing.

## 14.3 Immunogenicity

Analysis of total and neutralizing antibody response and other immunological parameters will be primarily descriptive and involve both inter-participant and intra-participant comparisons.

#### 14.4 Pharmacodynamic Analyses

Plasma FVIII protein concentrations and FVIII activities determined over the course of the study will primarily be evaluated and summarized with descriptive statistical measures (eg, mean, standard deviation, CV%, min, median, max).

#### 14.5 Safety Analysis

The Medical Dictionary for Regulatory Activities terminology (MedDRA) will be used by the Sponsor to assign system organ class and preferred term classification to events and diseases, based on the original terms entered on the eCRF.

All AEs will be coded using the current version of MedDRA. The incidence of AEs will be summarized by system organ class, preferred term, relationship to study drug, and severity. A by-subject listing will be provided for those subjects who experience a serious AE (SAE), including death, or experience an AE associated with early withdrawal from the study or study drug.

Clinical laboratory data will be summarized by the type of laboratory test. For each clinical laboratory test, descriptive statistics will be provided on Baseline as well as all subsequent visits. Descriptive statistics for physical examination results and vital signs will also be provided.

Detailed statistical methods will be provided in the SAP.

#### 14.6 Determination of Sample Size

Approximately 40 subjects may be dosed in the study. Assuming a rate of subject discontinuation of up to 15%, a sample size of 40 will provide at least 90% power to demonstrate that the change in median hFVIII activity at Weeks 48-52 from baseline is statistically significant assuming an effect size of 0.6, using a one-sample t-test with a 2-sided significance level of 0.049. Similarly, the sample size of 40 will also have at least 90% power for hypothesis testing of the first secondary efficacy endpoint, i.e., the change in annualized FVIII utilization (IU/kg) from baseline, assuming an effect size of 0.6, using a one-sample t-test with a 2-sided significance level of 0.049.

Regarding the second secondary endpoint, ie, the non-inferiority test for change in the annualized number of bleeding episodes requiring exogenous FVIII replacement treatment, in the pivotal studies of recent approved FVIII replacement products, the estimated ABRs are consistent across different studies and products. The mean ABRs of prophylactic treatment groups range from 3 to 6, approximately, and the mean ABRs of episodic treatment groups range from 30 to 60, approximately. The non-inferiority margin of 3.5 is chosen to preserve



90% of the efficacy of prophylactic over episodic treatment, justified by advantages of BMN 270 over FVIII replacement treatment. These advantages observed in the dose cohort 6E13 vg/kg in Study 270-201 include:

- Stable and durable FVIII activity levels protective against the majority of bleeds without FVIII trough levels
- Significant reduction in need for FVIII replacement therapies
- Improved quality of life

Assuming the mean and standard deviation of the change in ABR from baseline are 0 and 6 bleeds per year, respectively, a sample size of 40 with a discontinuation rate of 15% will provide at least 90% power for testing non-inferiority using a margin of 3.5, using a one sample t-test at a 2-sided significance level of 0.049.

#### **14.7 Analysis Populations**

The efficacy analysis set will be comprised of all subjects who have received the BMN 270 infusion.

The safety population will consist of all subjects who receive BMN 270 infusion during the study.

#### **14.8 Changes in the Conduct of the Study or Planned Analyses**

Only BioMarin may modify the protocol. Any change in study conduct considered necessary by the Investigator will be made only after consultation with BioMarin, who will then issue a formal protocol amendment to implement the change. The only exception is when an Investigator considers that a subject's safety is compromised without immediate action. In these circumstances, immediate approval of the chairman of the IRB/IEC/REB must be sought, and the Investigator should inform BioMarin and the full IRB/IEC/REB within 2 working days after the emergency occurs.

With the exception of minor administrative or typographical changes, the IRB/IEC/REB must review and approve all protocol amendments. Protocol amendments that have an impact on subject risk or the study objectives, or require revision of the ICF, must receive approval from the IRB/IEC/REB prior to their implementation.

When a protocol amendment substantially alters the study design or the potential risks or burden to subjects, the ICF will be amended and approved by BioMarin and the IRB/IEC/REB, and all active subjects must again provide informed consent.

|   |         |         |
|---|---------|---------|
|  | 270-301 | Page 95 |
|---|---------|---------|

## 15 DATA MONITORING COMMITTEE

An independent DMC will be convened for this study. The duties of the DMC will include:

- Conducting an ongoing review of individual subject safety and efficacy data during the study.
- Recommending whether to enroll subjects at a different dose level based on emerging data from 270-301 and the overall risk/benefit analysis of BMN 270.
- Reviewing ongoing safety and efficacy data for comparability of drug manufacturing lots within 270-301 and between 270-201 and 270-301.
- Making other recommendations on the conduct and reporting of the trial based on their evaluation of clinical data.

Details on the composition of the committee, frequency of meetings, and other committee functions and parameters are included in the DMC Charter and in the Statistical Analysis Plan (SAP).

## 16 COSTS, COMPENSATION, AND SUBJECT INJURY

There will be no charge to study subjects to be in this study. BioMarin will pay all costs of tests, procedures, and treatments that are part of this study. In addition, after IRB/IEC/REB approval, BioMarin may reimburse the reasonable cost of travel for study-related visits in accordance with BioMarin's travel and reimbursement policy. BioMarin will not pay for any hospitalizations, tests, or treatments for medical problems of any sort related solely to the study subject's disease. Costs associated with such hospitalizations, tests, and treatments should be billed and collected in the way that such costs are usually billed and collected outside the study.

The Investigator should contact BioMarin immediately upon notification that a study subject has been injured by the study drug or by procedures performed as part of the study. Any subject who experiences a study-related injury should be instructed by the Investigator to seek immediate medical treatment at a pre-specified medical institution if possible, or at the closest medical treatment facility if necessary. The subject should be given the name of a person to contact to seek further information about, and assistance with, treatment for study-related injuries. The treating physician should bill the subject's health insurance company or other third party payer for the cost of this medical treatment. If the cost of the medical treatment is not covered by health insurance or another third party that usually pays these costs, then either BioMarin or the institution may pay for reasonable and necessary medical services to treat the injuries caused by the study drug or study procedures. In some jurisdictions, BioMarin is obligated by law to pay for study-related injuries without prior recourse to third party payer billing and/or regardless of fault. If this is the case, BioMarin will comply with the law.

## 17 CASE REPORT FORMS AND SOURCE DOCUMENTS

Electronic case report forms will be provided for each subject. The Investigator must review and electronically sign the completed eCRF casebook to verify its accuracy.

eCRFs must be completed using a web-based application developed and validated. Study site personnel will be trained on the application and will enter the clinical data from source documentation. Unless explicitly allowed in the eCRF instructions, blank data fields are not acceptable.

In the event of an entry error, or if new information becomes available, the value will be corrected by deselecting the erroneous response and then selecting or entering the factual response. In compliance with ICH GCP Guidelines and 21 CFR Part 11, the system will require the personnel making the correction to enter a reason for changing the value. The documented audit trail will include the reason for the change, the original value, the new value, the time of the correction and the identity of the operator.

BioMarin's policy is that study data on the eCRFs must be verifiable to the source data, which necessitates access to all original recordings, laboratory reports, and subject records. In addition, all source data should be attributable (signed and dated). The Investigator must therefore agree to allow direct access to all source data. Subjects must also allow access to their medical records, and subjects will be informed of this and will confirm their agreement when giving informed consent. If an Investigator or institution refuses to allow access to subject records because of confidentiality, arrangements must be made to allow an "interview" style of data verification.

A site monitor designated by BioMarin will compare the eCRFs with the original source documents at the study site and evaluate them for completeness and accuracy before designating them as "Source Data Verified" (SDV). If an error is discovered at any time or a clarification is needed, the site monitor, or designee, will create an electronic query on the associated field. Site personnel will then answer the query by either correcting the data or responding to the query. The site monitor will then review the response and determine either to close the query or re-query the site if the response does not fully address the question. This process is repeated until all open queries have been answered and closed.

Before a subject's eCRF casebook can be locked, data fields must be source data verified and all queries closed. Refer to the Study Monitoring Plan for details on which fields must be source data verified. The Investigator will then electronically sign the casebook, specifying that the information on the eCRFs is accurate and complete. The Data Manager, or designee, will then set the status of the forms, visits, and the entire casebook to Locked. Upon

|          |         |         |
|----------|---------|---------|
| B:OMARIN | 270-301 | Page 98 |
|----------|---------|---------|

completion of the CSR, an electronic copy of each site's casebooks will be copied to a compact disk (CD) and sent to each site for retention with other study documents.

## **18 STUDY MONITORING AND AUDITING**

Qualified individuals designated by BioMarin will monitor all aspects of the study according to GCP and standard operating procedures for compliance with applicable government regulations. The Investigator agrees to allow these monitors direct access to the clinical supplies, dispensing, and storage areas and to the clinical files, including original medical records, of the study subjects, and, if requested, agrees to assist the monitors. The Investigator and staff are responsible for being present or available for consultation during routinely scheduled site visits conducted by BioMarin or its designees.

Members of BioMarin's GCP Compliance Department or designees may conduct an audit of a clinical site at any time before, during, or after completion of the study. The Investigator will be informed if an audit is to take place and advised as to the scope of the audit. Representatives of the FDA or other Regulatory Agencies may also conduct an audit of the study. If informed of such an inspection, the Investigator should notify BioMarin immediately. The Investigator will ensure that the auditors have access to the clinical supplies, study site facilities, original source documentation, and all study files.

## 19 RETENTION OF RECORDS

The Investigator must retain all study records required by BioMarin and by the applicable regulations in a secure and safe facility. The Investigator must consult a BioMarin representative before disposal of any study records, and must notify BioMarin of any change in the location, disposition or custody of the study files. The Investigator /institution must take measures to prevent accidental or premature destruction of essential documents, that is, documents that individually and collectively permit evaluation of the conduct of a study and the quality of the data produced, including paper copies of study records (eg, subject charts) as well as any original source documents that are electronic as required by applicable regulatory requirements.

All study records must be retained for at least 2 years after the last approval of a marketing application in the US or an ICH region and until (1) there are no pending or contemplated marketing applications in the U.S. or an ICH region or (2) at least 2 years have elapsed since the formal discontinuation of clinical development of the IP. The Investigator /institution should retain subject identifiers for at least 15 years after the completion or discontinuation of the study. Subject files and other source data must be kept for the maximum period of time permitted by the hospital, institution or private practice, but not less than 15 years. These documents should be retained for a longer period, however, if required by the applicable regulatory requirements or by a BioMarin agreement. BioMarin must be notified and will assist with retention should Investigator /institution be unable to continue maintenance of subject files for the full 15 years. It is the responsibility of BioMarin to inform the Investigator /institution as to when these documents no longer need to be retained.

## **20 USE OF INFORMATION AND PUBLICATION**

BioMarin recognizes the importance of communicating medical study data and therefore encourages the publication of these data in reputable, peer-reviewed scientific journals and at seminars or conferences. The details of the processes of producing and reviewing reports, manuscripts, and presentations based on the data from this study will be described in the Clinical Trial Agreement between BioMarin and the Investigator/Institution. Consideration for authorship of all publications will be based on compliance with the Uniform Requirements for Manuscripts Submitted to Biomedical Journals (“Uniform Requirements”) of the International Committee of Medical Journal Editors (ICMJE) ([http://www.icmje.org/ethical\\_1author.html](http://www.icmje.org/ethical_1author.html)) and good publication practices (GPP).



## 21 REFERENCES

- Bainbridge, JW, Smith, AJ, Barker, SS, Robbie, S et. al. Effect of gene therapy on visual function in Leber's congenital amaurosis. *N Engl J Med* 358[21], 2231-2239. 2008.
- Batts KP & Ludwig J. Chronic hepatitis: an update on terminology and reporting. *Am J Surg Pathol* 19:1409-1417. 1995.
- Bedossa P, Pynard T, French METAVIR Cooperative Study Group. An algorithm for grading activity in chronic hepatitis C. *Hepatology* 24;289-293. 1996.
- Berntorp, E, Peake, I, Budde, U, Laffan, M et. al. von Willebrand's disease: a report from a meeting in the Aland islands. *Haemophilia* 18 Suppl 6, 1-13. 2012.
- Brooks R. EuroQol: the current state of play. *Health Policy*. 1996;37:53-72.
- Croteau, GA, Martin, DB, Camp, J, Yost, M et. al. Evaluation of exposure and health care worker response to nebulized administration of tgAAVCF to patients with cystic fibrosis. *Ann Occup Hyg* 48[8], 673-681. 2004.
- D'Avola, D. Phase 1 Clinical Trial of Liver Directed Gene Therapy with rAAV5-PBGD in Acute Intermittent Porphyria: Preliminary Safety Data. *J Hepatol* 60[S58]. 2014.
- Den Ujil, Mauser Bunschoten, Roosendaal, Schutgens et. al. Clinical Severity of haemophilia A: does the classification of the 1950s still stand? *Haemophilia* 17, 849-853. 2011.
- EuroQol Group. EuroQol – a new facility for the measurement of health-related quality of life. *Health Policy*. 1990;16:199-208.
- George, LA, Sullivan, S, Teitel, J, Cuker, A et al. Preliminary results of a phase 1/2 trial of SPK-9001, a hyperactive FIX variant delivered by a novel capsid, demonstrate consistent factor IX activity levels at the lowest dose cohort. *Haemophilia* 22[Suppl. 4], 151-152. 2016.
- Hay, CR, DiMichele, DM. The principal results of the International Immune Tolerance Study: a randomized dose comparison  
12. *Blood* 119[6], 1335-1344. 2012.
- Haemo-QoL Study Group. Scoring Manual. Available at: <http://haemoqol.de/scoring/manual>. Last accessed 28 July 2017.
- Kaufman, RJ, Powell, JS. Molecular approaches for improved clotting factors for hemophilia 1. *Blood* 122[22], 3568-3574. 2013.

- Maguire, AM, High, KA, Auricchio, A, Wright, JF et. al. Age-dependent effects of RPE65 gene therapy for Leber's congenital amaurosis: a phase 1 dose-escalation trial. *Lancet* 374[9701], 1597-1605. 2009.
- Mahlangu, J, Powell, JS, Ragni, MV, Chowdary, P et. al. Phase 3 study of recombinant factor VIII Fc fusion protein in severe hemophilia A  
8. *Blood* 123[3], 317-325. 2014.
- Manno, CS, Chew, AJ, Hutchison, S, Larson, PJ et. al. AAV-mediated factor IX gene transfer to skeletal muscle in patients with severe hemophilia B  
1. *Blood* 101[8], 2963-2972. 2003.
- Manno, CS, Pierce, GF, Arruda, VR, Glader, B et. al. Successful transduction of liver in hemophilia by AAV-Factor IX and limitations imposed by the host immune response. *Nat Med* 12[3], 342-347. 2006.
- Mannucci, PM, Tuddenham, EG. The hemophilias--from royal genes to gene therapy  
1. *N Engl J Med* 344[23], 1773-1779. 2001.
- McIntosh, J, Lenting, PJ, Rosales, C, Lee, D et. al. Therapeutic levels of FVIII following a single peripheral vein administration of rAAV vector encoding a novel human factor VIII variant. *Blood* 121[17], 3335-3344. 2013.
- Miesbach, W, Tangelder, M, Klamroth, R, Schutgens, R et al. Updated results from a dose escalating study in adult patients with haemophilia B with AMT-060 (AAV5-hFIX) gene therapy. *Haemophilia* 22[Suppl. 4], 151-152. 2016.
- Mingozi, F and High, KA. Immune responses to AAV vectors: overcoming barriers to successful gene therapy. *Blood* 122[1], 23-36. 2013.
- Monahan, P, Walsh CE, Powell JS, Konkle BA et al. Update on a phase 1/2 open-label trial of BAX335, an adeno-associated virus 8 (AAV8) vector-based gene therapy program for hemophilia B. *J Thromb Haemostasis* 13[Suppl 2], 1-997. 2015.
- Nagel, K, Walker, I, Decker, K, Chan, AK et. al. Comparing bleed frequency and factor concentrate use between haemophilia A and B patients  
1. *Haemophilia* 17[6], 872-874. 2011.
- Nathwani, AC, Gray, JT, Ng, CY, Zhou, J et. al. Self-complementary adeno-associated virus vectors containing a novel liver-specific human factor IX expression cassette enable highly efficient transduction of murine and nonhuman primate liver  
3. *Blood* 107[7], 2653-2661. 2006.

- Nathwani, AC, McIntosh, J, Davidoff, AM. An update on gene therapy for hemophilia. *Curr Hematol Rep* 4[4], 287-293. 2005.
- Nathwani, AC, Reiss, UM, Tuddenham, EG, Rosales, C et. al. Long-term safety and efficacy of factor IX gene therapy in hemophilia B. *N Engl J Med* 371[21], 1994-2004. 2014.
- Nathwani, AC, Rosales, C, McIntosh, J, Rastegarlar, G et. al. Long-term safety and efficacy following systemic administration of a self-complementary AAV vector encoding human FIX pseudotyped with serotype 5 and 8 capsid proteins. *Mol Ther* 19[5], 876-885. 2011.
- Nathwani, AC, Tuddenham, EG. Epidemiology of coagulation disorders. *Baillieres Clin Haematol* 5[2], 383-439. 1992.
- Nathwani, AC, Tuddenham, EG, Rangarajan, S, Rosales, C et. al. Adenovirus-associated virus vector-mediated gene transfer in hemophilia B. *N Engl J Med* 365[25], 2357-2365. 2011.
- Paneda, A, Lopez-Franco, E, Kaepfel, C, Unzu, C et. al. Safety and liver transduction efficacy of rAAV5-cohPBGD in nonhuman primates: a potential therapy for acute intermittent porphyria. *Hum Gene Ther* 24[12], 1007-1017. 2013.
- Pasi, J, Wong, W, Rangarajan, S, Wilde, J et al. Interim results of an open-label, phase 1/2 study of BMN 270, an AAV5-FVIII gene transfer in severe hemophilia A. *Haemophilia* 22[Suppl. 4], 151-152. 2016.
- Reilly, M. WPAI Scoring. 2002. Available at: [http://www.reillyassociates.net/WPAI\\_Scoring.html](http://www.reillyassociates.net/WPAI_Scoring.html). Last accessed 28 July 2017.
- Recht M, Neufeld EJ, Sharma VR, Solem CT et al. Impact of Acute Bleeding on Daily Activities of Patients with Congenital Hemophilia with Inhibitors and Their Caregivers and Families: Observations from the Dosing Observational Study in Hemophilia (DOSE). *Value in Health*. 2014;17:744-748.
- Rentz A, Flood E, Altisent C, Bullinger M et al. Cross-cultural development and psychometric evaluation of a patient-reported health-related quality of life questionnaire for adults with haemophilia. *Haemophilia* 2008;14(5):1023-34.
- Schenk-Braat, EA, van Mierlo, MM, Wagemaker, G, Bangma, CH et. al. An inventory of shedding data from clinical gene therapy trials. *J Gene Med* 9[10], 910-921. 2007.
- Simonelli, F, Maguire, AM, Testa, F, Pierce, EA et. al. Gene therapy for Leber's congenital amaurosis is safe and effective through 1.5 years after vector administration. *Mol Ther* 18[3], 643-650. 2010.

Srivastava, A, Brewer, AK, Mauser-Bunschoten, EP, Key, NS et. al. Guidelines for the management of hemophilia 128. *Haemophilia* 19[1], e1-47. 2013.

Stonebraker, JS, Brooker, M, Amand, RE, Farrugia, A et. al. A study of reported factor VIII use around the world. *Haemophilia* 16[1], 33-46. 2010.

United States Department of Health and Human Services. Guidelines for the Use of Antiretroviral Agents in HIV-1-Infected Adults and Adolescents. 2014. Available at <https://aidsinfo.nih.gov/guidelines/html/1/adult-and-adolescent-arv-guidelines/458/plasma-hiv-1-rna--viral-load--and-cd4-count-monitoring>. Last accessed 28 July 2017.

Van Genderen FR, Westers P, Heijnen L, De Kleijn P et al. Measuring patients' perceptions on their functional abilities: validation of the Haemophilia Activities List. *Haemophilia*. 2006;12:36-46.

Watkins, PB, Kaplowitz, N, Slattery, JT, Colonese, CR et al. Aminotransferase Elevations in Healthy Adults Receiving 4 Grams of Acetaminophen Daily: A Randomized Controlled Trial. *JAMA* 296[1], 87-93. 2006.

White, GC, Rosendaal, F, Aledort, FM, Lusher, JM et al. Definitions in hemophilia. Recommendation of the scientific subcommittee on factor VIII and factor IX of the scientific and standardization committee of the International society on Thrombosis and Haemostasis. *Thromb Haemost.* 85[3], 560. 2001.

## 22 INVESTIGATOR RESPONSIBILITIES

### 22.1 Conduct of Study and Protection of Human Patients

In accordance with FDA Form 1572 and/or principles of ICH GCP, the Investigator will ensure that:

- He or she will conduct the study in accordance with the relevant, current protocol and will only make changes in a protocol after notifying the sponsor, except when necessary to protect the safety, rights, or welfare of subjects.
- He or she will personally conduct or supervise the study.
- He or she will inform any potential subjects, or any persons used as controls, that the drugs are being used for investigational purposes, and he or she will ensure that the requirements relating to obtaining informed consent in 21 CFR Part 50 and/or ICH sections 2.9 and 4.8 are met. As well, he or she will ensure that IRB/IEC review and approval in 21 CFR Part 56 and/or ICH section 2.6 are met.
- He or she will report to the sponsor adverse experiences that occur in the course of the investigation in accordance with 21 CFR 312.64 and/or ICH Section 4.11.
- He or she has read and understands the information in the Investigator's Brochure, including potential risks and side effects of the drug.
- His or her staff and all persons who assist in the conduct of the study are informed about their obligations in meeting the above commitments
- Adequate and accurate records in accordance with 21 CFR 312.62 and/or ICH section 4.9 are kept, and those records are available for inspection in accordance with 21 CFR 312.68 and/or ICH section 4.9.7.
- The IRB/EC/REB complies with the requirements of 21 CFR Part 56, ICH Section 3.0, and other applicable regulations, and conducts initial and ongoing reviews and approvals of the study. He or she will also ensure that any change in research activity and all problems involving risks to human subjects or others are reported to the IRB/EC/REB. Additionally, he or she will not make any changes in the research without IRB/EC/REB approval, except where necessary to eliminate apparent immediate hazards to human subjects.
- He or she agrees to comply with all other requirements regarding the obligations of clinical Investigators and all other pertinent requirements in 21 CFR Part 312 and/or ICH E6 R2.

|                 |         |          |
|-----------------|---------|----------|
| <b>B:OMARIN</b> | 270-301 | Page 107 |
|-----------------|---------|----------|

**23 SIGNATURE PAGE**

**Protocol Title:** A Phase 3 Open-Label, Single Arm Study To Evaluate The Efficacy and Safety of BMN 270, an Adenovirus-Associated Virus Vector-Mediated Gene Transfer of Human Factor VIII in Hemophilia A Patients with Residual FVIII Levels  $\leq 1$  IU/dL Receiving Prophylactic FVIII Infusions

**Protocol Number:** 270-301

I have read the forgoing protocol and agree to conduct this study as outlined. I agree to conduct the study in compliance with all applicable regulations and guidelines, including E6 ICH, as stated in the protocol, and other information supplied to me.

\_\_\_\_\_  
Investigator Signature Date

Printed name: \_\_\_\_\_

**Accepted for the Sponsor:**

**PI** \_\_\_\_\_ **PI** \_\_\_\_\_  
Date

Printed name: **PI** \_\_\_\_\_ Clinical Sciences \_\_\_\_\_



# BIOMARIN™

## CLINICAL STUDY PROTOCOL

**Study Title:** A Phase 3 Open-Label, Single-Arm Study To Evaluate The Efficacy and Safety of BMN 270, an Adeno-Associated Virus Vector-Mediated Gene Transfer of Human Factor VIII in Hemophilia A Patients with Residual FVIII Levels  $\leq$  1 IU/dL Receiving Prophylactic FVIII Infusions

**Protocol Number:** 270-301

**Active Investigational Product:** AAV5-hFVIII-SQ

**IND/European Union Drug Regulating Authorities Clinical Trials (EudraCT) Number:** 2017-003215-19  
IND #: 017659

**Indication:** Hemophilia A

**Sponsor:** BioMarin Pharmaceutical Inc.  
105 Digital Drive  
Novato, CA 94949

**Development Phase:** Phase 3

**Sponsor's Responsible Medical Monitor:** PI [REDACTED], MD, MPhil  
PI [REDACTED]  
BioMarin Pharmaceutical Inc.  
105 Digital Drive  
Novato, CA 94949

**Duration of Subject Participation:** Approximately 264 weeks

**Dose:** 6E13 vg/kg

**Study Population:** Males aged 18 or older

**Date of Original Protocol:** 14 August 2017

**Date of Amendment 1 (United States Specific):** 2 October 2017

**Date of Amendment 1 (Global)** 25 January 2018

Property of BioMarin

**CONFIDENTIAL**

May not be divulged, published, or otherwise disclosed to others without prior written approval from BioMarin.

This study will be conducted according to the principles of Good Clinical Practice as described in the U.S. Code of Federal Regulations and the International Conference on Harmonisation Guidelines, including the archiving of essential documents



---

## CLINICAL STUDY PROTOCOL AMENDMENT SUMMARY

### Amendment 1

**Date: 25 January 2018**

---

#### RATIONALE AND SUMMARY OF CHANGES

A summary of major changes covered by Amendment 1 to the 270-301 protocol is provided below:

1. The sample size of the study has been changed to 70.

**Rationale:** The increased sample size will support evaluation of superiority in annualized bleed rate post- versus pre-BMN 270 infusion.

2. The timing of the interim analysis has been changed to occur after 20 treated subjects have completed the Week 26 visit. The interim analysis has been changed to only perform hypothesis testing for the primary endpoint. The method for adjusting multiplicity has been changed accordingly.

**Rationale:** Given the observation in the BMN 270-201 study that FVIII activity levels remain elevated from before Week 26 to after Week 52, this sample size is sufficient to assess safety and efficacy of BMN 270 after 20 treated subjects have completed the Week 26 visit. Due to the reduced sample size, only the primary endpoint will be tested at the interim analysis. The method for adjusting multiplicity of the interim analysis and the final analysis has been changed accordingly.

3. Testing of the exploratory samples for the Direct Thrombin Activity Test and TGA Assay has been clarified as optional.

**Rationale:** While exploratory samples for Direct Thrombin Activity Test and TGA Assay will be collected at the time points indicated in the protocol, analysis of these samples will be optional.

4. Specific testing of TNF- $\alpha$  and IL10a single nucleotide polymorphisms has been removed from biomarker testing.

**Rationale:** These biomarkers are designed to inform the risk of FVIII inhibitor development. There have not been any cases of FVIII inhibitor development observed in Study 270-201, so analyses of TNF- $\alpha$  and IL10a single nucleotide polymorphisms have not been indicated. FVIII inhibitors are not expected to develop in this study; however, in the event that inhibitors are observed, sufficient exploratory samples will have been collected to perform these tests.





5. A fasting lipid panel (blood triglycerides, total cholesterol, HDL cholesterol, and LDL cholesterol) has been added on the day of the BMN 270 infusion.

**Rationale:** This will enable assessment of levels of triglycerides and lipids on the efficacy and safety of BMN 270.

6. The initial von Willebrand Factor antigen (VWF:Ag) assessment has been moved from the Screening visit to the Baseline visit.

**Rationale:** This was moved to only evaluate this laboratory test in individuals who have been deemed eligible to receive BMN 270.

7. The frequency of liver function and FVIII testing has been increased during the Years 2-5 follow-up period. Testing will be performed every 4 weeks (+ 2 weeks, or as scheduled to align with other scheduled study visits) during year 2, and every 6 weeks ( $\pm$  2 weeks) during years 3-5.

**Rationale:** This change will enable more frequent monitoring of subjects' liver function and FVIII testing during the long-term follow-up period and enable investigators to evaluate safety and efficacy more closely.

8. It has been clarified that post-steroid testing for hepatitis B/C reactivation should be performed only in subjects who have a previous history of positive hepatitis B/C tests.

**Rationale:** The previous language in the protocol was unclear and may have led some investigators to think all subjects (including those with no prior evidence of viral hepatitis exposure) should be retested.

9. The Patient Reported Outcomes, Burdens, and Experiences (PROBE) questionnaire has been added as a quality of life assessment.

**Rationale:** The PROBE questionnaire will enable assessment of additional patient-reported outcomes of both hemophilia A patients and controls globally.

10. In the event of a positive Bethesda assay result during Years 3-5, an additional sample has been added to be collected within 4 weeks of the visit where the positive result was obtained.

**Rationale:** During Years 3-5, samples are being regularly collected every 6 weeks. However, to align with EMA guidance (which suggests that a confirmatory test on a second sample should be done within a month after a positive Bethesda assay result), language has been added to require the site to conduct an unscheduled visit within 4 weeks after the date when the positive Bethesda result was obtained.

11. Emicizumab, fitusiran, and concizumab have been added as prohibited medications starting 30 days before Screening and through the end of the study.

**Rationale:** Experimental hemophilia treatments are prohibited during the study as they could affect the assessment of FVIII levels in 270-301 subjects.



---

12. Subjects will be advised to abstain from blood or sperm donation after BMN 270 infusion until there is no further evidence of vector shedding.

**Rationale:** Vector shedding in the blood and semen following BMN 270 infusion has been observed, which could serve for vector transmission if subjects were to donate blood or semen following the BMN 270 infusion.

13. Updates have been made to clarify the description of the drug material.

14. Number of sites has been increased from approximately 30 to approximately 40.

15. Language concerning acceptable methods of contraception for purposes of study inclusion/exclusion has been clarified.

16. The vector schematic has been updated.

17. Changes have been made to correct minor errors and for purposes of clarity and consistency.

Refer to Section 24 for a summary of revisions to the original protocol (dated 24 August 2017).



## 2 SYNOPSIS

|   |   |  |
|---|---|--|
| <p><b>NAME OF COMPANY</b><br/>BioMarin Pharmaceutical Inc.<br/>105 Digital Drive<br/>Novato, CA 94949</p> <p><b>NAME OF FINISHED PRODUCT:</b><br/>BMN 270</p> <p><b>NAME OF ACTIVE INGREDIENT:</b><br/>AAV5-hFVIII-SQ</p>   | <p><b>SUMMARY TABLE</b><br/>Referring to Part of the<br/>Dossier:</p> <p>Volume:</p> <p>Page:</p> <p>Reference:</p> | <p><b>FOR NATIONAL<br/>AUTHORITY USE<br/>ONLY:</b></p> |
| <p><b>TITLE OF STUDY:</b><br/>A Phase 3 Open-Label, Single-Arm Study To Evaluate The Efficacy and Safety of BMN 270, an Adeno-Associated Virus Vector-Mediated Gene Transfer of Human Factor VIII in Hemophilia A Patients with Residual FVIII Levels <math>\leq 1</math> IU/dL Receiving Prophylactic FVIII Infusions</p>  |   |  |
| <p><b>PROTOCOL NUMBER:</b><br/>270-301</p>  |   |  |
| <p><b>STUDY SITES:</b><br/>Approximately 40 sites worldwide.</p>  |   |  |
| <p><b>PHASE OF DEVELOPMENT:</b><br/>Phase 3</p>   |   |  |
| <p><b>STUDY RATIONALE:</b><br/>Hemophilia A (HA) is an X-linked recessive bleeding disorder that affects approximately 1 in 5,000 males. It is caused by deficiency in the activity of coagulation factor VIII (FVIII), an essential cofactor in the intrinsic coagulation pathway. This disorder can be either inherited, due to a genetic aberrancy, or an acquired immunologic process, leading to insufficient quantities of FVIII or a dysfunctional FVIII, but all are characterized by a defective coagulation process. The clinical phenotype of HA patients generally correlates tightly with the level of residual expression. Severe HA is classified as FVIII activity less than 1% of wild-type (<math>&lt; 1</math> IU/dL), moderate disease comprises 1-5% of wild-type activity and the mild form is 5-40% activity. The clinical manifestations of severe HA are frequent spontaneous bleeding episodes, predominantly in joints and soft tissues, with a substantially increased risk of death from hemorrhage when the brain is involved. Subjects with moderate disease can exhibit manifestations similar to those seen in patients with severe HA, resulting in a comparable bleeding phenotype.</p> <p>Treatment of severe HA presently consists of intravenous injection of plasma-derived or recombinant human FVIII protein (rhFVIII) concentrates, both as prophylaxis 2-3 times per week, and at the time of a bleed, to prevent or control bleeding episodes, respectively. The half-life for FVIII (12 to 18 hours for most approved products) necessitates frequent infusions, and although a major advance in the treatment of HA, it remains common for severe HA patients to continue to have multiple bleeding events on prophylactic therapy (median ABR of 1-4 with prophylaxis treatment in a recently published retrospective observational study (<a href="#">Berntorp, 2016, Haemophilia</a>) and between 1-2 in 6 prospective FVIII interventional studies) and on-demand-only therapy (median ABR of 4.5-18 in a recently published retrospective study (<a href="#">Berntorp, 2016,</a></p> |   |  |



| <b>NAME OF COMPANY</b><br>BioMarin Pharmaceutical Inc.<br>105 Digital Drive<br>Novato, CA 94949<br><br><b>NAME OF FINISHED PRODUCT:</b><br>BMN 270<br><br><b>NAME OF ACTIVE INGREDIENT:</b><br>AAV5-hFVIII-SQ  | <b>SUMMARY TABLE</b><br>Referring to Part of the<br>Dossier:<br><br>Volume:<br><br>Page:<br><br>Reference: | <b>FOR NATIONAL<br/>           AUTHORITY USE<br/>           ONLY:</b> |
|--|--|---|
| <p>Haemophilia) and between 20-60 in 6 prospective FVIII interventional studies). The consequence of multiple bleeding events is the development of debilitating multiple-joint arthropathy and substantially increased risk of death. Chemical modification (eg, direct conjugation of polyethylene glycol (PEG) polymers) and bioengineering of FVIII (eg, FVIII-Fc fusion proteins) improve half-life by approximately 50%, and thus, show promise in reduced dosing and maintaining activity levels above a 1% trough for a greater proportion of the dosing interval. However, patients with severe HA who are treated with extended half-life FVIII remain dependent on multiple infusions to maintain critical levels of FVIII activity. There is therefore a strong unmet need for a fully preventive treatment of HA to give patients a FVIII level compatible with a normal and hemorrhage-free life.</p> <p>Gene therapy offers the potential of disease-modifying therapy by continuous endogenous production of active FVIII following a single intravenous infusion of a vector encoding the appropriate gene sequence for long-term episomal expression. Hemophilia A is well-suited for a gene replacement approach because clinical manifestations are attributable to the lack of a single gene product (FVIII) that circulates in minute amounts (200 ng/ml) in the plasma. Tightly regulated control of gene expression is not essential, and even modest increases in the level of FVIII (any increase of the plasma level by 2 ng/ml induces an increase in activity of 1%) can ameliorate the severe form of hemophilia A. Thus, relatively small changes in endogenous FVIII activity can result in clinically relevant improvements in disease phenotype. Finally, the circulating FVIII response to gene transduction can be assessed using validated quantitative rather than qualitative endpoints that are easily assayed using established laboratory techniques.</p> <p>Several different gene transfer strategies for FVIII replacement have been evaluated, but adeno-associated viral (AAV) vectors show the greatest promise. They have an excellent and well-defined safety profile, and can direct long-term transgene expression with tropism and promoter specificity for specific tissues, such as the liver (for serotypes 2, 5 and 8 among others). Indeed, an ongoing gene therapy clinical trial for a related disorder, hemophilia B, has established that stable (median follow-up of 3.2 years) expression of human factor IX (hFIX) at levels that are sufficient for conversion of their bleeding phenotype from severe to moderate or mild is achievable following a single peripheral vein infusion of AAV8-hFIX vector. Several participants in this trial have been able to discontinue factor prophylaxis without suffering spontaneous hemorrhages, even when they undertook activities that previously resulted in bleeding. Thus, gene therapy treatment has resulted in a substantial improvement in their quality of life (Nathwani, 2014, N Engl J Med). BMN 270 is an AAV5-based gene therapy vector that expresses the SQ form of hFVIII under the control of a hybrid human liver-specific promoter (Figure 1).</p> |  |   |

|   |   |   |
|---|---|---|
| <b>NAME OF COMPANY</b><br>BioMarin Pharmaceutical Inc.<br>105 Digital Drive<br>Novato, CA 94949<br><br><b>NAME OF FINISHED PRODUCT:</b><br>BMN 270<br><br><b>NAME OF ACTIVE INGREDIENT:</b><br>AAV5-hFVIII-SQ | <b>SUMMARY TABLE</b><br>Referring to Part of the Dossier:<br><br>Volume:<br><br>Page:<br><br>Reference: | <b>FOR NATIONAL AUTHORITY USE ONLY:</b> |
|---|---|---|

**Figure 1. hFVIII-SQ Vector Genome Schematic**

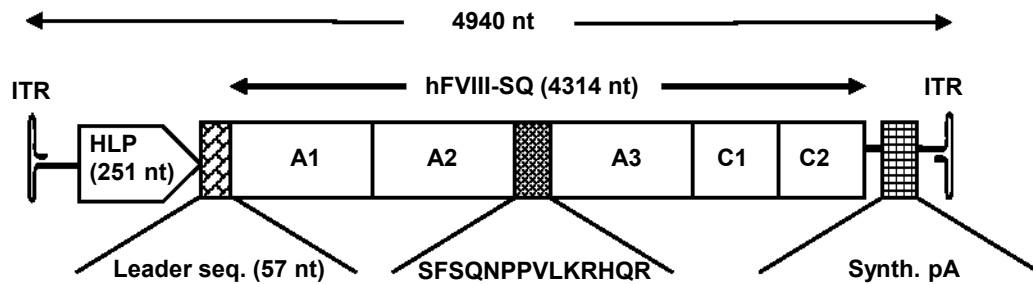

Legend –Note that schematic is not to scale; nt = nucleotides

BMN 270 will be delivered by a single intravenous dose and is designed to achieve stable, potentially life-long expression of active hFVIII in the plasma, synthesized from vector-transduced liver tissue.

BMN 270 is currently being evaluated in clinical study 270-201, an ongoing first-in-human, phase 1/2 dose escalation study in subjects with severe HA designed to assess the safety and efficacy of BMN 270 at various dose levels (6E12 vg/kg, 2E13 vg/kg, 4E13 vg/kg, 6E13 vg/kg). Specifically, 270-201 explores the relationship of vector dose to the augmentation of residual FVIII activity and whether these levels are sufficient to alter the clinical phenotype. Preliminary results from 270-201 have demonstrated that following gene transfer, FVIII activity above 15% (15 IU/dL) and, in many cases, within the normal range for FVIII, is achievable with a dose of 4-6E13 vg/kg with an acceptable safety profile (Pasi, 2017, Blood).

The current study is a Phase 3, single-arm, open-label study designed to assess whether, in an expanded sample, BMN 270 can safely alter the clinical phenotype of hemophilia A patients with residual FVIII activity  $\leq 1$  IU/dL, with an altered phenotype defined as achieving FVIII activity of  $\geq 15\%$  ( $\geq 15$  IU/dL).

**OBJECTIVES:**

The primary efficacy objective of the study is to:

- Assess the efficacy of BMN 270 defined as FVIII activity, as measured by one-stage clotting assay, during Weeks 49-52 following intravenous infusion of BMN 270



| <b>NAME OF COMPANY</b><br>BioMarin Pharmaceutical Inc.<br>105 Digital Drive<br>Novato, CA 94949<br><br><b>NAME OF FINISHED PRODUCT:</b><br>BMN 270<br><br><b>NAME OF ACTIVE INGREDIENT:</b><br>AAV5-hFVIII-SQ  | <b>SUMMARY TABLE</b><br>Referring to Part of the<br>Dossier:<br><br>Volume:<br><br>Page:<br><br>Reference: | <b>FOR NATIONAL<br/>           AUTHORITY USE<br/>           ONLY:</b> |
|--|--|---|
| <p>The secondary efficacy objectives of the study are to:</p> <ul style="list-style-type: none"> <li>Assess the impact of BMN 270 on usage of exogenous FVIII replacement therapy from Week 5 to Week 52</li> <li>Assess the impact of BMN 270 on the number of bleeding episodes requiring exogenous FVIII replacement therapy from Week 5 to Week 52</li> </ul> <p>The tertiary efficacy objective of the study is to:</p> <ul style="list-style-type: none"> <li>Assess the impact of BMN 270 on patient-reported outcomes (PROs) at Week 52 of the study compared to baseline</li> </ul> <p>The safety objectives of the study are to:</p> <ul style="list-style-type: none"> <li>Evaluate the safety of BMN 270 during the first 52 weeks following intravenous infusion</li> <li>Assess the long-term safety of BMN 270</li> </ul>   |  |   |
| <p><b>STUDY DESIGN AND PLAN:</b></p> <p>This is a Phase 3, single-arm, open-label study in hemophilia A patients with residual FVIII levels <math>\leq 1</math> IU/dL treated continuously with prophylactic exogenous FVIII for a minimum of one year prior to enrollment. Subjects will be enrolled at approximately 40 sites worldwide. Subjects must have high-quality, well-documented historical data available concerning previous bleeding episodes and exogenous FVIII usage over the previous 12 months in order to be eligible to enroll in the study.</p> <p>Approximately 70 adult subjects with severe HA will receive a 6E13 vg/kg dose of BMN 270 as a single intravenous infusion. Approximately 20 subjects will enroll in the study with at least 12 months of well-documented high-quality historical data concerning previous bleeding episodes and exogenous FVIII usage, while approximately 50 subjects will enroll in the study after having completed at least 6 months' participation in the BioMarin-sponsored non-interventional study 270-902.</p> |  |   |



|   |   |  |
|---|---|--|
| <p><b>NAME OF COMPANY</b><br/>BioMarin Pharmaceutical Inc.<br/>105 Digital Drive<br/>Novato, CA 94949</p> <p><b>NAME OF FINISHED PRODUCT:</b><br/>BMN 270</p> <p><b>NAME OF ACTIVE INGREDIENT:</b><br/>AAV5-hFVIII-SQ</p> | <p><b>SUMMARY TABLE</b><br/>Referring to Part of the Dossier:</p> <p>Volume:</p> <p>Page:</p> <p>Reference:</p> | <p><b>FOR NATIONAL AUTHORITY USE ONLY:</b></p> |
|---|---|--|

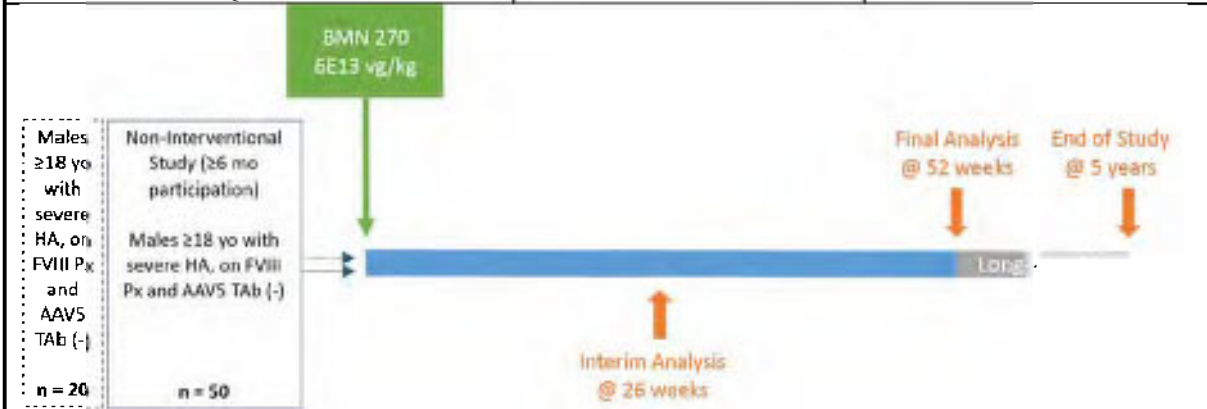

yo = years old, HA = hemophilia A, FVIII = factor VIII, Px = prophylaxis, AAV5 = adeno-associated virus, serotype 5, TAB = total antibody, mo = month, vg = vector genomes, kg = kilogram, f/u = follow-up

The Data Monitoring Committee (DMC) will review available safety and efficacy (eg, FVIII activity) data during the study on an ongoing basis and may determine, based on emerging data and the risk/benefit profile, that further enrollment at 6E13 vg/kg should be discontinued in favor of a different dose of BMN 270, not to exceed 6E13 vg/kg. If the DMC recommends a dosing modification, then additional subjects may be enrolled, up to a total of approximately 70 subjects, at the new BMN 270 dose level (regardless of the number of subjects previously enrolled at 6E13 vg/kg).

An interim analysis is planned after 20 treated subjects have completed the Week 26 visit. The final analysis for the study will be performed after all subjects have been followed for 52 weeks post-BMN 270 infusion. After the final analysis, safety and efficacy will then continue to be assessed long-term in all subjects for a total of approximately 5 years.

To avoid breakthrough bleeding, subjects will only discontinue exogenous prophylactic FVIII replacement therapy after FVIII activity has reached at least 5 IU/dL or 4 weeks following infusion of BMN 270, whichever is earlier. Four weeks represents the time by which endogenous production of FVIII following gene transfer is expected to be efficacious.

Throughout the study, subjects with FVIII activity below 5 IU/dL may be monitored more frequently at the discretion of the Medical Monitor and the Investigator. In subjects who show an initial response to BMN 270 but who later have FVIII activity decline to < 5 IU/dL, the investigator and medical monitor will review the subject's FVIII activity levels and discuss whether to resume prior FVIII prophylaxis. In addition, the investigator will notify the subject of





| <b>NAME OF COMPANY</b><br>BioMarin Pharmaceutical Inc.<br>105 Digital Drive<br>Novato, CA 94949<br><br><b>NAME OF FINISHED PRODUCT:</b><br>BMN 270<br><br><b>NAME OF ACTIVE INGREDIENT:</b><br>AAV5-hFVIII-SQ  | <b>SUMMARY TABLE</b><br>Referring to Part of the<br>Dossier:<br><br>Volume:<br><br>Page:<br><br>Reference: | <b>FOR NATIONAL<br/>           AUTHORITY USE<br/>           ONLY:</b> |
|--|--|---|
| <p>his FVIII activity levels and will discuss with the subject the risk of bleeding and when (and if) prior FVIII prophylaxis will be resumed.</p> <p>There will be an ongoing review of individual subject safety and efficacy data by the Medical Monitor and the DMC. FVIII activity by a validated assay will be used to evaluate efficacy over the course of the study. Therapeutic oral corticosteroids may be initiated when a subject's ALT values are elevated or based on review of FVIII activity and liver enzyme data, and subsequent dosage adjustments made, after consultation between the Investigator and the Medical Monitor. Any safety signal may trigger a review of the data and possible additional immunogenicity studies or other diagnostics deemed necessary that include an assessment of cellular immune responses using collected peripheral blood mononuclear cells (PBMCs).</p>   |  |   |
| <p><b>NUMBER OF SUBJECTS PLANNED:</b><br/>           Approximately 70 subjects may enroll into the study.</p>  |  |   |
| <p><b>DIAGNOSIS AND ALL CRITERIA FOR INCLUSION AND EXCLUSION:</b><br/>           Patients are eligible to be included in the study only if all of the following criteria apply:</p> <ol style="list-style-type: none"> <li>1. Males <math>\geq</math> 18 years of age with hemophilia A and residual FVIII levels <math>\leq</math> 1 IU/dL as evidenced by medical history, at the time of signing the informed consent.</li> <li>2. Must have been on prophylactic FVIII replacement therapy for at least 12 months prior to study entry. High-quality, well-documented historical data concerning bleeding episodes and FVIII usage over the previous 12 months must be available.</li> <li>3. Treated/exposed to FVIII concentrates or cryoprecipitate for a minimum of 150 exposure days (EDs).</li> <li>4. Willing and able to provide written, signed informed consent after the nature of the study has been explained and prior to any study-related procedures.</li> <li>5. No history of FVIII inhibitor, and results from a Bethesda assay with Nijmegen modification of less than 0.6 Bethesda Units (BU) on 2 consecutive occasions (the most recent one of which should be tested at the central laboratory) at least one week apart within the past 12 months</li> </ol> |  |   |





| <b>NAME OF COMPANY</b><br>BioMarin Pharmaceutical Inc.<br>105 Digital Drive<br>Novato, CA 94949<br><br><b>NAME OF FINISHED PRODUCT:</b><br>BMN 270<br><br><b>NAME OF ACTIVE INGREDIENT:</b><br>AAV5-hFVIII-SQ  | <b>SUMMARY TABLE</b><br>Referring to Part of the<br>Dossier:<br><br>Volume:<br><br>Page:<br><br>Reference: | <b>FOR NATIONAL<br/>           AUTHORITY USE<br/>           ONLY:</b> |
|--|--|---|
| <p>6. Sexually active participants must agree to use an acceptable method of effective contraception--double barrier contraception (ie, condom + diaphragm; or condom or diaphragm + spermicidal gel or foam) or their female partner either using hormonal contraceptives or having an intrauterine device--for at least 6 months post-infusion. After 6 months, subjects may stop contraception use only if they have had 3 consecutive semen samples with no detectable viral vector DNA.</p> <p>7. Willing to abstain from alcohol consumption for at least the first 52 weeks following BMN 270 infusion.</p> <p>8. HIV positive patients may be enrolled, only if the patient has a CD4 count &gt; 200/mm<sup>3</sup> and an undetectable viral load.</p> <p>Patients are excluded from the study if any of the following criteria apply:</p> <ol style="list-style-type: none"> <li>1. Detectable pre-existing antibodies to the AAV5 capsid.</li> <li>2. Any evidence of active infection or any immunosuppressive disorder, except for HIV infection as described in the inclusion criterion above.</li> <li>3. Significant liver dysfunction with any of the following abnormal laboratory results:               <ul style="list-style-type: none"> <li>• ALT (alanine transaminase) or AST &gt;2X ULN;</li> <li>• Total bilirubin &gt;2X ULN;</li> <li>• Alkaline phosphatase &gt;2X ULN; or</li> <li>• INR (international normalized ratio) ≥ 1.4.</li> </ul> </li> </ol> <p>Subjects whose liver laboratory assessments fall outside of these ranges may undergo repeat testing and, if eligibility criteria are met on retest, may be enrolled after confirmation by the Medical Monitor. In addition, subjects with abnormal laboratory results related to confirmed benign liver conditions (eg, Gilbert's syndrome) are considered eligible for the study notwithstanding their abnormal laboratory results and may be enrolled after discussion with the Medical Monitor.</p> <ol style="list-style-type: none"> <li>4. Prior liver biopsy showing significant fibrosis of 3 or 4 as rated on a scale of 0-4 on the Batts-Ludwig (Batts 1995) or METAVIR (Bedossa 1996) scoring systems, or an equivalent grade of fibrosis if an alternative scale is used.</li> <li>5. Evidence of any bleeding disorder not related to hemophilia A.</li> <li>6. Platelet count of &lt; 100 x 10<sup>9</sup>/L.</li> </ol> |  |   |



| <b>NAME OF COMPANY</b><br>BioMarin Pharmaceutical Inc.<br>105 Digital Drive<br>Novato, CA 94949<br><br><b>NAME OF FINISHED PRODUCT:</b><br>BMN 270<br><br><b>NAME OF ACTIVE INGREDIENT:</b><br>AAV5-hFVIII-SQ  | <b>SUMMARY TABLE</b><br>Referring to Part of the<br>Dossier:<br><br>Volume:<br><br>Page:<br><br>Reference: | <b>FOR NATIONAL<br/>           AUTHORITY USE<br/>           ONLY:</b> |
|--|--|---|
| <ol style="list-style-type: none"> <li>7. Creatinine <math>\geq</math> 1.5 mg/dL.</li> <li>8. Liver cirrhosis of any etiology as assessed by liver ultrasound.</li> <li>9. Chronic or active hepatitis B as evidenced by positive serology testing and confirmatory HBV DNA testing. Refer to the Centers for Disease Control (CDC) table for the interpretation of serological test results in the Laboratory Manual.</li> <li>10. Active Hepatitis C as evidenced by detectable HCV RNA or currently on antiviral therapy.</li> <li>11. Active malignancy, except non-melanoma skin cancer.</li> <li>12. History of hepatic malignancy.</li> <li>13. History of arterial or venous thromboembolic events (eg, deep vein thrombosis, non-hemorrhagic stroke, pulmonary embolism, myocardial infarction, arterial embolus), with the exception of catheter-associated thrombosis for which anti-thrombotic treatment is not currently ongoing.</li> <li>14. Known inherited or acquired thrombophilia, including conditions associated with increased thromboembolic risk, such as atrial fibrillation.</li> <li>15. Treatment with any investigational product within 30 days or 5 half-lives of the investigational product prior to the screening period. For subjects who have received a prior investigational product, all ongoing adverse events (AEs) experienced while receiving that investigational product must have resolved prior to screening for this study.</li> <li>16. Any condition that, in the opinion of the Investigator or Sponsor would prevent the patient from fully complying with the requirements of the study (including possible corticosteroid treatment outlined in the protocol) and/or would impact or interfere with evaluation and interpretation of subject safety or efficacy result.</li> <li>17. Prior treatment with any vector or gene transfer agent.</li> <li>18. Major surgery planned in the 52-week period following the infusion with BMN 270.</li> <li>19. Use of systemic immunosuppressive agents, not including corticosteroids, or live vaccines within 30 days before the BMN 270 infusion.</li> <li>20. Concurrent enrollment in another clinical study, unless it is an observational (non-interventional) clinical study that does not interfere with the requirements of the current protocol or have the potential to impact the evaluation of efficacy and safety of BMN 270 and with prior consultation with the Medical Monitor.</li> </ol> |  |   |



|  |   |  |
|--|---|--|
| <p><b>NAME OF COMPANY</b><br/>BioMarin Pharmaceutical Inc.<br/>105 Digital Drive<br/>Novato, CA 94949</p> <p><b>NAME OF FINISHED PRODUCT:</b><br/>BMN 270</p> <p><b>NAME OF ACTIVE INGREDIENT:</b><br/>AAV5-hFVIII-SQ</p>  | <p><b>SUMMARY TABLE</b><br/>Referring to Part of the<br/>Dossier:</p> <p>Volume:</p> <p>Page:</p> <p>Reference:</p> | <p><b>FOR NATIONAL<br/>AUTHORITY USE<br/>ONLY:</b></p> |
| <p>21. Known allergy or hypersensitivity to BMN 270 investigational product formulation.</p> <p>22. Unwilling to receive blood or blood products for treatment of an adverse event and/or a bleeding episode.</p>  |   |  |
| <p><b>INVESTIGATIONAL PRODUCT(S), DOSE, ROUTE AND REGIMEN:</b><br/>Each subject will receive a single intravenous infusion of BMN 270 at 6E13 vg/kg. The volume of infusion will depend on the subject's weight.</p>   |   |  |
| <p><b>REFERENCE THERAPY(IES), DOSE, ROUTE AND REGIMEN:</b><br/>No reference therapy will be evaluated in this study.</p>   |   |  |
| <p><b>DURATION OF TREATMENT:</b><br/>BMN 270 is given as a single dose by intravenous infusion.</p>  |   |  |
| <p><b>CRITERIA FOR EVALUATION:</b></p> <p><u>Efficacy:</u></p> <p>Primary efficacy endpoint:</p> <ul style="list-style-type: none"> <li>• Change of the hFVIII activity, as measured by one-stage clotting assay, during Weeks 49-52 post-BMN 270 infusion from baseline. Each subject's hFVIII activity during Weeks 49-52 is defined as the median of the values obtained during this 4-week window. Values for hFVIII activity will be excluded if obtained within 72 hours since the last infusion of exogenous FVIII protein concentrates.</li> </ul> <p>Secondary efficacy endpoints:</p> <ul style="list-style-type: none"> <li>• Change in the annualized utilization (IU/kg) of exogenous FVIII replacement therapy during Week 5 to Week 52 post-BMN 270 infusion from the baseline utilization of exogenous FVIII replacement therapy calculated using subjects' historical medical records during the year prior to enrollment.</li> <li>• Change in the annualized number of bleeding episodes requiring exogenous FVIII replacement treatment (annualized bleeding rate, ABR) during Week 5 to Week 52 of the study post-BMN 270 infusion from the baseline ABR calculated using subjects' historical medical records during the year prior to enrollment.</li> </ul> <p>Tertiary efficacy endpoints:</p> <ul style="list-style-type: none"> <li>• Change from baseline in the total score of HAEMO-QoL-A at Week 52 of the study post-BMN 270 infusion.</li> <li>• Change from baseline in the EQ-5D-5L score at Week 52 of the study post-BMN 270 infusion.</li> </ul> |   |  |



| <b>NAME OF COMPANY</b><br>BioMarin Pharmaceutical Inc.<br>105 Digital Drive<br>Novato, CA 94949<br><br><b>NAME OF FINISHED PRODUCT:</b><br>BMN 270<br><br><b>NAME OF ACTIVE INGREDIENT:</b><br>AAV5-hFVIII-SQ   | <b>SUMMARY TABLE</b><br>Referring to Part of the<br>Dossier:<br><br>Volume:<br><br>Page:<br><br>Reference: | <b>FOR NATIONAL<br/>           AUTHORITY USE<br/>           ONLY:</b> |
|---|--|---|
| <ul style="list-style-type: none"> <li>• Change from baseline in the Haemophilia Activities List (HAL) score at Week 52 of the study post-BMN 270 infusion.</li> <li>• Change from baseline in the Work Productivity and Activity Impairment plus Classroom Impairment Questions: Hemophilia Specific (WPAI+CIQ:HS) score at Week 52 of the study post-BMN 270 infusion.</li> <li>• Change from baseline in Patient Reported Outcomes, Burdens, and Experiences (PROBE) score at Week 52 of the study post-BMN 270 infusion.</li> </ul> <p><u>Safety:</u></p> <p>The following safety outcome measurements will be assessed:</p> <ul style="list-style-type: none"> <li>• Incidence of adverse events (AEs) and serious AEs (SAEs)</li> <li>• Change in clinical laboratory tests (serum chemistry and hematology)</li> <li>• Change in vital signs</li> <li>• Change in physical examination</li> <li>• Vector shedding (blood, urine, semen, feces, saliva)</li> <li>• Liver function tests (LFTs, including ALT, AST, GGT, LDH, bilirubin, alkaline phosphatase)</li> <li>• Immune response to FVIII transgene product and AAV5 capsid proteins</li> </ul> <p>Each subject will have comprehensive surveillance monitoring of LFTs (once per week for Weeks 1-36, and then once every 2 weeks from Weeks 37-52) during Year 1. LFTs will be monitored every four weeks during Year 2 and then every 6 weeks during Years 3-5 post-dose in the safety extension; the frequency and duration of LFT testing may be changed based on discussion between the Medical Monitor and the Investigator, review of subject data, and/or by independent DMC feedback.</p> <p>There will be a detailed assessment of cellular and humoral responses to AAV5 capsid and FVIII protein.</p> <p><u>Pharmacodynamics:</u></p> <p>The FVIII protein concentration and activity level as measured by a validated immunoassay and a validated FVIII activity assay, respectively, will be used for plasma profiles; FVIII protein and activity will be used to determine PD parameters.</p> |  |   |



|  |   |  |
|--|---|--|
| <p><b>NAME OF COMPANY</b><br/>BioMarin Pharmaceutical Inc.<br/>105 Digital Drive<br/>Novato, CA 94949</p> <p><b>NAME OF FINISHED PRODUCT:</b><br/>BMN 270</p> <p><b>NAME OF ACTIVE INGREDIENT:</b><br/>AAV5-hFVIII-SQ</p>  | <p><b>SUMMARY TABLE</b><br/>Referring to Part of the<br/>Dossier:</p> <p>Volume:</p> <p>Page:</p> <p>Reference:</p> | <p><b>FOR NATIONAL<br/>AUTHORITY USE<br/>ONLY:</b></p> |
| <p><b>STATISTICAL METHODS:</b></p> <p><u>Sample Size</u></p> <p>Seventy (70) subjects may be dosed in the study. The sample size for this study is based on clinical and statistical considerations in order to provide sufficient data to assess both safety and efficacy of BMN 270.</p> <p>A sample size of 70 will provide at least 95% power to demonstrate that the change in hFVIII activity during Weeks 49-52 from baseline is greater than 0, assuming an effect size of 0.6, using a one-sample t-test with a 2-sided significance level of 0.025.</p> <p>A sample size of 70 will provide at least 95% power to demonstrate that the change in the annualized utilization (IU/kg) of exogenous FVIII replacement therapy during Week 5 to Week 52 post-BMN 270 infusion from baseline is less than 0, assuming an effect size of 0.6, using a one-sample t-test with a 2-sided significance level of 0.025.</p> <p>A sample size of 70 will also have at least 95% power to demonstrate that the change in the annualized number of bleeding episodes requiring exogenous FVIII replacement treatment (ABR) during Week 5 to Week 52 of the study post-BMN 270 infusion from the baseline ABR is less than 3.5 (non-inferiority margin), assuming the pre- and post-BMN 270 infusion population mean ABRs are 3.5 and 1 respectively, using a one-sample t-test with a 2-sided significance level of 0.025. Under the same assumptions, a sample size of 70 will have approximately 90% power to demonstrate that the change is less than 0, i.e. superiority of BMN 270 against FVIII prophylaxis.</p> <p>Overall, a sample size of 70 will have greater than 80% power for testing the primary and secondary efficacy endpoints hierarchically at the final analysis with a 2-sided significance level of 0.025.</p> <p><u>Analysis Population</u></p> <p>The efficacy analysis set will consist of all subjects who receive BMN 270 infusion.<br/>The safety population is the same as the efficacy analysis set.</p> <p><u>Analysis</u></p> <p>For the primary efficacy endpoint at Week 52 (ie, the change in the hFVIII activity during Weeks 49-52 post-BMN 270 infusion from baseline, as measured by one-stage clotting assay), a one-sample t-test will be used to test the null hypothesis that the change is 0 or less against the alternative hypothesis that the change is greater than 0. Descriptive summaries of the proportions of subjects whose FVIII activity during Weeks 49-52 is greater than or equal to select thresholds, such as 15, 25 and 30 IU/dL, and the confidence intervals of the proportions will also be provided.</p> |   |  |



| <b>NAME OF COMPANY</b><br>BioMarin Pharmaceutical Inc.<br>105 Digital Drive<br>Novato, CA 94949<br><br><b>NAME OF FINISHED PRODUCT:</b><br>BMN 270<br><br><b>NAME OF ACTIVE INGREDIENT:</b><br>AAV5-hFVIII-SQ   | <b>SUMMARY TABLE</b><br>Referring to Part of the<br>Dossier:<br><br>Volume:<br><br>Page:<br><br>Reference: | <b>FOR NATIONAL<br/>           AUTHORITY USE<br/>           ONLY:</b> |
|---|--|---|
| <p>The FVIII activity as measured by chromogenic assay will be analyzed similarly, as a supportive analysis.</p> <p>For the first secondary efficacy endpoint at Week 52 (ie, the change in the annualized utilization (IU/kg) of exogenous FVIII replacement therapy during Weeks 5-52 post-BMN 270 infusion from baseline), a one-sample t-test will be performed to test the null hypothesis that the change is 0 or greater against the alternative hypothesis that the change is less than 0.</p> <p>For the second secondary efficacy endpoint at Week 52 (ie, the change in the annualized number of bleeding episodes requiring exogenous FVIII replacement treatment during Weeks 5-52 post-BMN 270 infusion from baseline), a one-sample t-test will be performed to test for non-inferiority of BMN 270 against FVIII prophylaxis (ie, the baseline ABR calculated using subjects' historical medical records during the year prior to enrollment) using a margin of 3.5, i.e. to test the null hypothesis that the change is 3.5 or greater against the alternative hypothesis that the change is less than 3.5. If non-inferiority is demonstrated, the test for superiority of BMN 270 against FVIII prophylaxis will be performed.</p> <p>The primary efficacy endpoint and secondary efficacy endpoints will be tested hierarchically at the final analysis at Week 52 according to the order described above.</p> <p>An interim analysis is planned after 20 treated subjects have completed the Week 26 visit (or have discontinued study participation prior to Week 26). The primary efficacy endpoint for the interim analysis is change in the hFVIII activity, as measured by one-stage clotting assay, during Weeks 23-26 post-BMN 270 infusion from baseline. Each subject's hFVIII activity during Weeks 23-26 is defined as the median of the values obtained during this 4-week window. Values for hFVIII activity will be excluded if obtained within 72 hours since the last infusion of exogenous FVIII protein concentrates. A 2-sided one-sample t-test will be used to test the null hypothesis that the change is 0 or less against the alternative hypothesis that the change is greater than 0. In addition, subjects' hFVIII activity post-Week 23, defined as the median of the values obtained from Week 23 to the time of last follow-up, will be analyzed similarly as an important sensitivity analysis, utilizing additional data beyond Week 26.</p> <p>Descriptive summaries of the proportions of subjects whose FVIII activity during Weeks 23-26 and from Week 23 to the time of last follow-up is greater than or equal to select thresholds, such as 15, 25 and 30 IU/dL, and the confidence intervals of the proportions will be provided, respectively. The FVIII activity as measured by chromogenic assay will be analyzed similarly, as a supportive analysis.</p> <p>The Hochberg procedure will be used to adjust for multiplicity of the interim analysis at Week 26 and the final analysis at Week 52 of the primary efficacy endpoint. (Regardless of the interim analysis results, the study will continue and the final analysis will be performed at Week 52.) At</p> |  |   |



| <b>NAME OF COMPANY</b><br>BioMarin Pharmaceutical Inc.<br>105 Digital Drive<br>Novato, CA 94949<br><br><b>NAME OF FINISHED PRODUCT:</b><br>BMN 270<br><br><b>NAME OF ACTIVE INGREDIENT:</b><br>AAV5-hFVIII-SQ  | <b>SUMMARY TABLE</b><br>Referring to Part of the<br>Dossier:<br><br>Volume:<br><br>Page:<br><br>Reference: | <b>FOR NATIONAL<br/>           AUTHORITY USE<br/>           ONLY:</b> |
|--|--|---|
| <p>the final analysis at Week 52, the secondary efficacy endpoints will be tested hierarchically; the level of significance will be determined by the truncated Hochberg procedure for parallel gatekeeping.</p> <p>The secondary efficacy endpoints at the interim analysis (Week 26) will be summarized descriptively.</p> <p>The tertiary endpoints will be analyzed at the interim (Week 26) and final (Week 52) analyses, irrespective of the aforementioned hierarchical testing.</p> <p>Analysis of safety endpoints will be primarily descriptive. The incidence of AEs will be summarized by system organ class, preferred term, relationship to study drug, seriousness, and severity. Clinical laboratory test values, vital signs, vector shedding and immune response parameters will be summarized descriptively by visit.</p> |  |   |





### 3 TABLE OF CONTENTS

|       |  |    |
|-------|--|----|
| 2     | SYNOPSIS.....  | 5  |
| 3     | TABLE OF CONTENTS.....   | 18 |
| 4     | LIST OF ABBREVIATIONS AND DEFINITIONS OF TERMS.....                | 23 |
| 5     | ETHICS.....  | 26 |
| 5.1   | Institutional Review Board or Independent Ethics Committee.....    | 26 |
| 5.2   | Ethical Conduct of Study.....                                      | 26 |
| 5.3   | Subject Information and Informed Consent.....                      | 27 |
| 6     | INVESTIGATORS AND STUDY ADMINISTRATIVE STRUCTURE.....              | 28 |
| 7     | INTRODUCTION.....  | 29 |
| 7.1   | Nonclinical Studies.....   | 29 |
| 7.2   | Previous Clinical Studies.....                                     | 30 |
| 7.3   | Study Rationale.....   | 30 |
| 7.4   | Summary of Overall Risks and Benefits.....                         | 33 |
| 8     | STUDY OBJECTIVES.....  | 34 |
| 9     | INVESTIGATIONAL PLAN.....  | 35 |
| 9.1   | Overall Study Design and Plan.....                                 | 35 |
| 9.2   | Discussion of Study Design, Including Choice of Control Group..... | 50 |
| 9.3   | Selection of Study Population.....                                 | 50 |
| 9.3.1 | Inclusion Criteria.....  | 50 |
| 9.3.2 | Exclusion Criteria.....  | 51 |
| 9.3.3 | Removal of Subjects from Treatment or Assessment.....              | 53 |
| 9.3.4 | Subject Identification and Replacement of Subjects.....            | 55 |
| 9.3.5 | Duration of Subject Participation.....                             | 55 |
| 9.4   | Treatments.....  | 55 |
| 9.4.1 | Treatments Administered.....                                       | 55 |
| 9.4.2 | Identity of Investigational Product.....                           | 55 |
| 9.4.3 | Storage.....   | 55 |
| 9.4.4 | Directions for Administration.....                                 | 55 |
| 9.4.5 | Method of Assigning Subjects to Treatment Groups.....              | 56 |





|        |  |    |
|--------|--|----|
| 9.4.6  | Selection of Dose Used in the Study .....  | 56 |
| 9.4.7  | Blinding .....   | 57 |
| 9.4.8  | Prior and Concomitant Medications .....  | 57 |
| 9.4.9  | Treatment Compliance .....   | 60 |
| 9.5    | Investigational Product Accountability .....   | 60 |
| 9.5.1  | Return and Disposition of Clinical Supplies .....  | 61 |
| 9.6    | Dietary or Other Protocol Restrictions .....   | 61 |
| 9.7    | Safety and Efficacy Variables .....  | 61 |
| 9.7.1  | Safety and Efficacy Measurements Assessed .....  | 61 |
| 9.7.2  | Primary Efficacy Variables .....   | 61 |
| 9.7.3  | Secondary Efficacy Variables .....   | 62 |
| 9.7.4  | Tertiary Efficacy Variables .....  | 63 |
| 9.7.5  | Immunogenicity .....   | 64 |
| 9.7.6  | Pharmacodynamics .....   | 64 |
| 9.7.7  | Exploratory Assessments .....  | 64 |
| 9.7.8  | Safety Variables .....   | 65 |
| 10     | REPORTING ADVERSE EVENTS .....   | 72 |
| 10.1   | Safety Parameters and Definitions .....  | 72 |
| 10.1.1 | Adverse Events .....   | 72 |
| 10.2   | Serious Adverse Events .....   | 73 |
| 10.2.1 | Events of Special Interest (EOSI) .....  | 73 |
| 10.3   | Methods and Timing for Capturing and Assessing Safety Parameters .....                     | 74 |
| 10.3.1 | Adverse Event Reporting Period .....   | 74 |
| 10.3.2 | Eliciting Adverse Events .....   | 74 |
| 10.3.3 | Assessment of Seriousness, Severity, and Causality .....                                   | 74 |
| 10.4   | Procedures for Recording Adverse Events .....  | 77 |
| 10.4.1 | Recording Adverse Events on a eCRF .....   | 77 |
| 10.5   | Reporting Requirements .....   | 80 |
| 10.5.1 | Expedited Reporting Requirements .....   | 80 |
| 10.5.2 | Institutional Review Board or Independent Ethics Committee<br>Reporting Requirements ..... | 81 |



|         |  |    |
|---------|--|----|
| 10.6    | Follow-up of Subjects after Adverse Events.....                              | 81 |
| 10.7    | Post-Study Adverse Events.....   | 81 |
| 10.8    | Urgent Safety Measures.....  | 82 |
| 10.9    | BioMarin Pharmacovigilance Contact Information.....                          | 83 |
| 11      | APPROPRIATENESS OF MEASUREMENTS.....   | 84 |
| 12      | STUDY PROCEDURES.....  | 85 |
| 12.1    | Prestudy.....  | 85 |
| 12.2    | Screening Visit.....   | 85 |
| 12.2.1  | “Smart Rescreening” Visit.....   | 86 |
| 12.3    | Baseline Visit.....  | 87 |
| 12.4    | Treatment Visit/BMN 270 Infusion Visit (Day 1).....                          | 88 |
| 12.5    | BMN 270 Infusion Follow-Up Visits – Weeks 1-26.....                          | 88 |
| 12.5.1  | Once per week (Weeks 1 through 26).....                                      | 88 |
| 12.5.2  | Week 1 – Day 4.....  | 89 |
| 12.5.3  | Week 1 – Day 8.....  | 89 |
| 12.5.4  | Every 2 Weeks (Week 2, 4, 6, 8, 10, 12, 14, 16, 18, 20, 22, 24, and 26)..... | 89 |
| 12.5.5  | Weeks 2, 4, 10, 16, 22, and 26.....  | 89 |
| 12.5.6  | Weeks 2, 3, 4, 6, 8, 12, 16, 20, 24, and 26.....                             | 89 |
| 12.5.7  | Weeks 4, 12, and 26.....   | 90 |
| 12.5.8  | Every 4 Weeks (Weeks 4, 8, 12, 16, 20, and 24) Plus Week 26.....             | 90 |
| 12.5.9  | Every 8 Weeks (Weeks 8, 16, and 24).....                                     | 90 |
| 12.5.10 | Weeks 6, 13, 16, 20, 24, and 26.....   | 90 |
| 12.5.11 | Weeks 12 and 26.....   | 90 |
| 12.5.12 | Week 13 and 26.....  | 90 |
| 12.5.13 | Week 16.....   | 91 |
| 12.5.14 | Week 20, 24, and 26.....   | 91 |
| 12.6    | Post-Infusion Follow-Up – Weeks 27-52.....                                   | 91 |
| 12.6.1  | Every Visit.....   | 91 |
| 12.6.2  | Weeks 28, 30, 32, 34, 36, 44, and 52.....                                    | 92 |
| 12.6.3  | Every 4 Weeks (Weeks 28, 32, 36, 40, 44, 48, 52).....                        | 92 |

|        |   |     |
|--------|---|-----|
| 12.6.4 | Weeks 32, 36, 44, and 52 .....  | 92  |
| 12.6.5 | Weeks 32, 36, 40, 44, 48, and 52 .....                                | 92  |
| 12.6.6 | Week 32, 36, and 52 .....   | 92  |
| 12.6.7 | Week 38 and 52 .....  | 92  |
| 12.6.8 | Week 52 .....   | 93  |
| 12.7   | Post-Infusion Follow-Up – Years 2-5 .....                             | 93  |
| 12.7.1 | Year 2 – Every 4 Weeks .....  | 93  |
| 12.7.2 | Years 3-5 – Every 6 Weeks .....                                       | 93  |
| 12.7.3 | Years 2-5 – Every 3 Months .....                                      | 94  |
| 12.7.4 | Years 2-5 – Every 4 Weeks (As Needed) .....                           | 94  |
| 12.7.5 | Years 2-5 – Every 6 Months .....                                      | 95  |
| 12.8   | Early Termination Visit .....   | 95  |
| 12.9   | End of Study .....  | 96  |
| 13     | DATA QUALITY ASSURANCE .....  | 98  |
| 14     | STATISTICAL METHODS AND DETERMINATION OF SAMPLE SIZE .....            | 99  |
| 14.1   | Statistical and Analytical Plans .....                                | 99  |
| 14.1.1 | Interim Analyses .....  | 99  |
| 14.1.2 | Procedures for Accounting for Missing, Unused and Spurious Data ..... | 100 |
| 14.2   | Primary and Secondary Efficacy Endpoints .....                        | 100 |
| 14.3   | Immunogenicity .....  | 102 |
| 14.4   | Pharmacodynamic Analyses .....  | 102 |
| 14.5   | Safety Analysis .....   | 102 |
| 14.6   | Determination of Sample Size .....                                    | 102 |
| 14.7   | Analysis Populations .....  | 103 |
| 14.8   | Changes in the Conduct of the Study or Planned Analyses .....         | 103 |
| 15     | DATA MONITORING COMMITTEE .....                                       | 104 |
| 16     | COSTS, COMPENSATION, AND SUBJECT INJURY .....                         | 105 |
| 17     | CASE REPORT FORMS AND SOURCE DOCUMENTS .....                          | 106 |
| 18     | STUDY MONITORING AND AUDITING .....                                   | 108 |
| 19     | RETENTION OF RECORDS .....  | 109 |

|  |     |
|--|-----|
| 20 USE OF INFORMATION AND PUBLICATION .....                  | 110 |
| 21 REFERENCES .....  | 111 |
| 22 INVESTIGATOR RESPONSIBILITIES .....                       | 115 |
| 22.1 Conduct of Study and Protection of Human Patients ..... | 115 |
| 23 SIGNATURE PAGE .....                                      | 116 |
| 24 PROTOCOL AMENDMENT TEXT REVISIONS .....                   | 117 |

### LIST OF TABLES

|   |    |
|---|----|
| Table 9.1.1: Schedule of Events – Screening and Infusion .....  | 37 |
| Table 9.1.2: Schedule of Events – Post-Infusion Follow-Up (Week 1-16) .....   | 40 |
| Table 9.1.3: Schedule of Events – Post-Infusion Follow-Up (Week 17-32) .....  | 43 |
| Table 9.1.4: Schedule of Events – Post-Infusion Follow-Up (Week 33 – Year 5) .....                                    | 46 |
| Table 9.1.5: Schedule of Events – Therapeutic Corticosteroids for LFT Elevations or<br>Decreased FVIII Activity ..... | 49 |
| Table 9.4.8.2.1: Adjustments to Corticosteroid Regimen .....  | 59 |
| Table 9.7.8.2.1: Clinical Laboratory Tests .....  | 66 |
| Table 9.7.8.3.1: Liver Function Tests .....   | 67 |
| Table 9.7.8.3.2: Evaluation of ALT Elevations .....   | 68 |
| Table 9.7.8.3.3: Viral and Autoimmune Hepatitis Testing .....   | 69 |
| Table 10.3.3.2.1: Adverse Event Grading (Severity) Scale .....  | 75 |
| Table 10.3.3.3.1: Causality Attribution Guidance .....  | 76 |

### LIST OF FIGURES

|   |    |
|---|----|
| Figure 7.3.1: hFVIII-SQ Vector Genome Schematic ..... | 32 |
|---|----|



## 4 LIST OF ABBREVIATIONS AND DEFINITIONS OF TERMS

### Abbreviations

|         |  |
|---------|--|
| AAV     | adeno-associated virus                                     |
| ABR     | annualized bleeding rate                                   |
| ADL     | activities of daily living                                 |
| ADR     | adverse drug reaction                                      |
| AE      | adverse event  |
| ALT     | alanine aminotransferase                                   |
| APTT    | activated partial thromboplastin time                      |
| ART     | anti-retroviral therapy                                    |
| BPV     | BioMarin Pharmacovigilance                                 |
| BU      | Bethesda Unit  |
| CFR     | Code of Federal Regulations                                |
| CRA     | clinical research associate                                |
| CRF     | case report form   |
| CSR     | clinical study report                                      |
| CTCAE   | Common Terminology Criteria for Adverse Events             |
| DMC     | Data Monitoring Committee                                  |
| eCRF    | electronic case report form                                |
| ED      | exposure days  |
| EOSI    | events of special interest                                 |
| ETV     | early termination visit                                    |
| EudraCT | European Union Drug Regulating Authorities Clinical Trials |
| FAS     | Full Analysis Set  |
| FDA     | Food and Drug Administration                               |
| FIH     | first-in-human   |
| FVIII   | coagulation factor VIII                                    |
| GCP     | Good Clinical Practice                                     |
| HA      | Hemophilia A   |
| HAL     | Haemophilia Activities List                                |
| hFIX    | human coagulation factor IX                                |
| hFVIII  | human coagulation factor VIII                              |
| HIPAA   | Health Insurance Portability and Accountability Act        |
| IB      | investigator brochure                                      |
| ICF     | informed consent form                                      |

---

|             |   |
|-------------|---|
| ICH         | International Conference on Harmonisation of Technical Requirements for Registration of Pharmaceuticals for Human Use |
| ICH E6 [R2] | ICH Harmonised Tripartite Guideline: Guideline for Good Clinical Practice E6  |
| IEC         | independent ethics committee  |
| IND         | Investigational New Drug (application)  |
| INR         | international normalized ratio  |
| IP          | investigational product   |
| IRB         | institutional review board  |
| IV          | intravenous   |
| LFT         | liver function test   |
| MedDRA      | Medical Dictionary for Regulatory Activities  |
| PBMC        | peripheral blood mononuclear cells  |
| PCR         | polymerase chain reaction   |
| PD          | pharmacodynamics  |
| PEG         | polyethylene glycol   |
| PK          | Pharmacokinetics  |
| PRO         | patient-reported outcome  |
| rhFVIII     | recombinant human FVIII protein   |
| REB         | research ethics board   |
| SAE         | serious adverse event   |
| SAP         | statistical analysis plan   |
| SDV         | source data verification  |
| TGA         | thrombin generation assay   |
| ULN         | upper limit of normal   |
| vg          | vector genomes  |
| VWF:Ag      | von Willebrand factor Antigen   |
| WPAI+CIQ:HS | Work Productivity and Activity Impairment plus Classroom Impairment Questions: Hemophilia Specific                    |

**Definition of Terms:**

## Investigational Product (IP):

“A pharmaceutical form of an active ingredient or placebo being tested or used as a reference in a clinical trial, including a product with a marketing authorization when used or assembled (formulated or packaged) in a way different from the approved form, or when used for an unapproved indication, or when used to gain further information about an approved use” (from International Conference on Harmonisation of Technical Requirements for Registration of Pharmaceuticals for Human Use ICH Harmonised Tripartite Guideline: Guideline for Good Clinical Practice E6 [ICH E6 (R2)]).

The terms “IP” and “study drug” may be used interchangeably in the protocol.





## **5 ETHICS**

BioMarin Pharmaceutical Inc. (hereafter referred to as BioMarin or the Sponsor) conducts its studies according to the highest ethical and scientific standards. The following sections articulate standards to which Investigators will be held accountable, as well as matters of compliance to document adherence to such standards.

### **5.1 Institutional Review Board or Independent Ethics Committee**

Investigators are expected to interact with Ethics Committees (ECs) promptly, as required, during the course of the study. This includes, but is not limited to, providing appropriate documentation to support study initiation and maintaining appropriate flow of safety and other information during the course of the study and for study close-out activities. BioMarin (or designee) will assist Investigators with access to timely and accurate information and with assurance of prompt resolution of any queries.

Prior to initiating the study, the Investigator will obtain written confirmation that the institutional review board (IRB) or independent ethics committee (IEC) [for Canadian protocols, Research Ethics Board (REB)] is properly constituted and compliant with International Conference on Harmonisation of Technical Requirements for Registration of Pharmaceuticals for Human Use (ICH) and Good Clinical Practice (GCP) requirements, applicable laws and local regulations. A copy of the confirmation from the IRB/IEC/REB will be provided to BioMarin or its designee. The Investigator will provide the IRB/IEC/REB with all appropriate material, including the protocol, Investigator's Brochure (IB), the Informed Consent Form (ICF) including compensation procedures, and any other written information provided to the subjects, including all ICFs translated for patients who do not speak the local language at the clinical site. The study will not be initiated and Investigational Product (IP) supplies will not be shipped to the site until appropriate documents from the IRB/IEC/REB confirming unconditional approval of the protocol, the ICF and all subject recruitment materials are obtained in writing by the Investigator and copies are received at BioMarin or its designee. The approval document should refer to the study by protocol title and BioMarin protocol number (if possible), identify the documents reviewed, and include the date of the review and approval. BioMarin will ensure that the appropriate reports on the progress of the study are made to the IRB/IEC/REB and BioMarin by the Investigator in accordance with applicable guidance documents and governmental regulations.

### **5.2 Ethical Conduct of Study**

It is expected that Investigators understand and comply with the protocol. This includes, but is not limited to: establishing and meeting enrollment commitments, including providing





eligible subjects for study enrollment; adhering to adverse event reporting, diagnostic, or other procedures as specified in the protocol; and assuring appropriate compliance with study treatment administration and accountability.

This study will be conducted in accordance with the following:

- European Clinical Trial Directive 2001/20/EC and Good Clinical Practice Directive 2005/28/EC, for studies conducted within any European country
- US Code of Federal Regulations (CFR) sections that address clinical research studies, and/or other national and local regulations, as applicable
- ICH Harmonised Tripartite Guideline: Guideline for Good Clinical Practice E6 (ICH E6) or E6(R2) (ICH E6R2) if adopted

Specifically, this study is based on adequately performed laboratory and animal experimentation and human Phase 1 study testing. The study will be conducted under a protocol reviewed and approved by an IRB/IEC/REB and will be conducted by scientifically and medically qualified persons. The potential benefits of the study are in proportion to the potential risks. The rights and welfare of the subjects will be respected and the Investigators conducting the study do not find the hazards to outweigh the potential benefits. Each subject will provide written, informed consent before any study-related tests or evaluations are performed.

### **5.3 Subject Information and Informed Consent**

A properly written and executed informed consent form (ICF), in compliance with ICH E6 (Section 4.8), United States Code of Federal Regulations (CFR) 21 CFR §50, European Clinical Trial Directive 2001/20/EC and Good Clinical Practice Directive 2005/28/EC, and other applicable local regulations, will be obtained for each subject prior to entering the subject into the study. The Investigator will prepare the ICF and provide the documents to BioMarin for approval prior to submission to the IRB/IEC/REB. BioMarin and the IRB/IEC/REB must approve the documents before they are implemented. A copy of the approved ICF, and if applicable, a copy of the approved subject information sheet and all ICFs translated to a language other than the native language of the clinical site must also be received by BioMarin or designee prior to any study-specific procedures being performed.

The Investigator will provide copies of the signed ICF to each subject and will maintain the original in the record file of the subject.



---

## 6 INVESTIGATORS AND STUDY ADMINISTRATIVE STRUCTURE

During administration of informed consent, expectations regarding participation in the study should be made clear to subjects. Patients who are not willing and/or are not able to comply with all aspects of the study should not be encouraged to participate.

Prior to beginning the study, the Investigator at each site must provide to BioMarin or designee a fully executed and signed Statement of Investigator (SOI) form. A US Food and Drug Administration (FDA) Form FDA 1572 serves as an acceptable SOI form. If Form FDA 1572 may not be used in a particular region, the Investigator must provide a fully executed SOI on the form provided by the Sponsor. All Investigators and Sub-Investigators must be listed on Form FDA 1572 or its equivalent SOI. Financial Disclosure Forms must also be completed for all Investigators and Sub-Investigators listed on the Form FDA 1572 or SOI who will be directly involved in the treatment or evaluation of subjects in this study.

The study will be administered by and monitored by employees or representatives of BioMarin. Clinical research associates (CRAs) or trained designees will monitor each site on a periodic basis and perform verification of source documentation for each subject as well as other required review processes. BioMarin's Regulatory Affairs Department (or designee) will be responsible for the timely reporting of serious adverse events (SAEs) to appropriate regulatory authorities as required.

In multicenter studies, a Coordinating Investigator will be identified who will be responsible for study overview. The Coordinating Investigator will read the clinical study report (CSR) and confirm that it accurately describes the conduct and results of the study, to the best of his or her knowledge. The Coordinating Investigator will be chosen on the basis of active participation in the study, ability to interpret data, and willingness to review and sign the report in a specified timeframe. The identity of the Coordinating Investigator and a list of all Investigators participating in the study will be provided in the CSR.

Clinical Laboratory assessments will be performed at a nominated central laboratory. Bioanalytical samples will be sent to the appropriate specialty laboratories for testing. Refer to laboratory manual for more details.



## 7 INTRODUCTION

Hemophilia A (HA) is an X-linked recessive bleeding disorder that affects approximately 1 in 5,000 males (Nathwani, 1992, *Baillieres Clin.Haematol.*). It is caused by mutations in the factor VIII (FVIII) gene that codes for FVIII protein, an essential cofactor in the coagulation pathway. Clinical manifestations of severe FVIII deficiency are frequent unprovoked bleeding episodes in joints and soft tissues causing permanent disability and occasionally death mostly after brain hemorrhage. Treatment in Western countries (Berntorp, 2012, *Haemophilia.*) consists of intravenous injection of plasma-derived or recombinant FVIII protein concentrates at the time of a bleed to control it or prophylactically to prevent bleeding episodes. The short half-life for FVIII (~8-12 hours) necessitates frequent infusions and makes this treatment prohibitively expensive for the majority of the world's hemophilia A patients. These individuals develop debilitating arthropathy and have a substantially increased risk of death from hemorrhage in life (Stonebraker, 2010, *Haemophilia.*). Chemical modification or bioengineering of FVIII may improve half-life to 18-19 hours (Kaufman, 2013, *Blood*). However, these extended half-life FVIII variants do not eliminate the need for lifelong FVIII protein administration (Hay, 2012, *Blood*).

Gene therapy offers the potential of disease-modifying therapy by continuous endogenous production of human FVIII (hFVIII) following a single administration of vector. Hemophilia A is well-suited for this approach because its clinical manifestations are attributable to the lack of a single gene product (FVIII) that circulates in low amounts (100-200 ng/ml) in the plasma. Tightly regulated control of gene expression is not essential, and a modest increase in the level of FVIII (a plasma level of 2 ng/ml protein leads to a 1% expression) can ameliorate the severe phenotype (Srivastava, 2013, *Haemophilia.*); thus, the therapeutic goal for gene therapy is a modest increase in hFVIII. Finally, the consequences of gene transfer can be assessed using simple quantitative rather than qualitative endpoints that can be easily assayed in most clinical laboratories.

BMN 270 contains the cDNA for the B-domain-deleted SQ FVIII with a liver-specific HLP transcription promoter. The expression cassette is inserted between AAV2 ITRs, and this genome is packaged in the AAV5 capsid. A comprehensive review of BMN 270 is contained in the IB supplied by BioMarin. Investigators are to review this document prior to initiating this study.

### 7.1 Nonclinical Studies

The nonclinical program supports a single IV infusion of BMN 270, the planned clinical route of administration, for the treatment of hemophilia A in male patients. This nonclinical



program took into account the guidelines and reflection papers for gene therapy medicinal products under EMA Advanced Therapies as well as FDA guidance. The primary pharmacodynamics (PD), pharmacokinetics (PK), and toxicity of IV BMN 270 were characterized in a series of single dose studies in species that were vector permissive and responsive to the transgene including normal CD-1 mice, a B- and T-cell deficient mouse model of hemophilia A (B6;129S-*Fcγ2m1Kaz*/J x B6.129S6-*Rag2<sup>tm1Fwa</sup>* N12; FVIII KO x Rag2), and normal cynomolgus and rhesus monkeys. Some PD studies evaluated additional PK, immunogenicity and toxicity endpoints.

Results of the nonclinical program to date are detailed in the IB supplied by BioMarin. Investigators are to review this document prior to initiating this study.

## 7.2 Previous Clinical Studies

Study BMN 270-201 is an ongoing Phase 1/2, dose-escalation study to assess the safety, tolerability, and efficacy of BMN 270 in patients with severe hemophilia A (FVIII  $\leq 1$  IU/dL). Subjects received a single BMN 270 infusion and are to be followed for safety and efficacy for up to 5 years. A total of 15 subjects have been enrolled at one of 4 dose levels (6E12, 2E13, 4E13, and 6E13 vg/kg).

A comprehensive review of safety, efficacy, and immunogenicity results from 270-201 as of the latest data cut is contained in the IB supplied by BioMarin. Investigators are to review this document prior to initiating this study.

## 7.3 Study Rationale

Hemophilia A (HA) is an X-linked recessive bleeding disorder that affects approximately 1 in 5,000 males. It is caused by deficiency in the activity of coagulation factor VIII (FVIII), an essential cofactor in the intrinsic coagulation pathway. This disorder can be either inherited, due to a genetic aberrancy or an acquired immunologic process, leading to insufficient quantities of FVIII or a dysfunctional FVIII, but all are characterized by a defective coagulation process. The clinical phenotype of HA patients generally correlates tightly with the level of residual expression. Severe HA is classified as FVIII activity less than 1% of wild type ( $< 1$  IU/dL), moderate disease comprises 1-5% of wild-type activity and the mild form is 5-40% activity. The clinical manifestations of severe HA are frequent spontaneous bleeding episodes, predominantly in joints and soft tissues, with a substantially increased risk of death from hemorrhage when the brain is involved. Subjects with moderate disease can exhibit manifestations similar to those seen in patients with severe HA, resulting in a comparable bleeding phenotype.



Treatment of severe HA presently consists of intravenous injection of plasma derived or recombinant human FVIII protein (rhFVIII) concentrates both as prophylaxis 2-3 times per week, and at the time of a bleed, to prevent or control bleeding episodes, respectively. The half-life for FVIII (12 to 18 hours for most approved products) necessitates frequent infusions, and although a major advance in the treatment of HA, it remains common for severe HA patients to continue to have multiple bleeding events on prophylactic therapy (median ABR of 1-4 with prophylaxis treatment in a recently published retrospective observational study ([Berntorp, 2016, Haemophilia](#)) and between 1-2 in 6 prospective FVIII interventional studies) and on-demand-only therapy (median ABR of 4.5-18 in a recently published retrospective study ([Berntorp, 2016, Haemophilia](#)) and between 20-60 in 6 prospective FVIII interventional studies). The consequence of multiple bleeding events is the development of debilitating multiple-joint arthropathy and substantially increased risk of death. Chemical modification (eg, direct conjugation of polyethylene glycol (PEG) polymers) and bioengineering of FVIII (eg, FVIII-Fc fusion proteins) improve half-life by approximately 50%, and thus, show promise in reduced dosing and maintaining activity levels above 1% trough for a greater proportion of the dosing interval. However, these extended half-life FVIII variants remain dependent on multiple infusions to maintain critical levels of FVIII activity in severe HA patients. There is therefore a strong unmet need for a fully preventive treatment of HA to give patients a FVIII level compatible with a normal and hemorrhage-free life.

Gene therapy offers the potential of disease-modifying therapy by continuous endogenous production of active FVIII following a single intravenous infusion of a vector encoding the appropriate gene sequence for long-term episomal expression. Hemophilia A is well-suited for a gene replacement approach because clinical manifestations are attributable to the lack of a single gene product (FVIII) that circulates in minute amounts (200 ng/ml) in the plasma. Tightly regulated control of gene expression is not essential, and even modest increases in the level of FVIII (any increase of the plasma level by 2 ng/ml induces an increase in activity of 1%) can ameliorate the severe form of the disease. Thus, relatively small changes in endogenous FVIII activity can result in clinically relevant improvements in disease phenotype. Finally, the circulating FVIII response to gene transduction can be assessed using validated quantitative rather than qualitative endpoints that are easily assayed using established laboratory techniques.

Several different gene transfer strategies for FVIII replacement have been evaluated, but adeno-associated viral (AAV) vectors show the greatest promise. They have an excellent and well-defined safety profile, and can direct long term transgene expression with tropism and

promoter specificity for specific tissues such as the liver (for serotypes 2, 5 and 8 among others). Indeed, an on-going gene therapy clinical trial for a related disorder, hemophilia B, has established that stable (median follow-up of 3.2 years) expression of human factor IX (hFIX) at levels that are sufficient for conversion of their bleeding phenotype from severe to moderate or mild is achievable following a single peripheral vein infusion of AAV8-hFIX vector. Several participants in this trial have been able to discontinue factor prophylaxis without suffering spontaneous hemorrhages, even when they undertook activities that previously resulted in bleeding. Thus, gene therapy treatment has resulted in a substantial improvement in their quality of life (Nathwani, 2014, *N Engl J Med*).

BMN 270 is an AAV5-based gene therapy vector that expresses the SQ form of hFVIII under the control of a hybrid human liver-specific promoter (Figure 7.3.1).

**Figure 7.3.1: hFVIII-SQ Vector Genome Schematic**

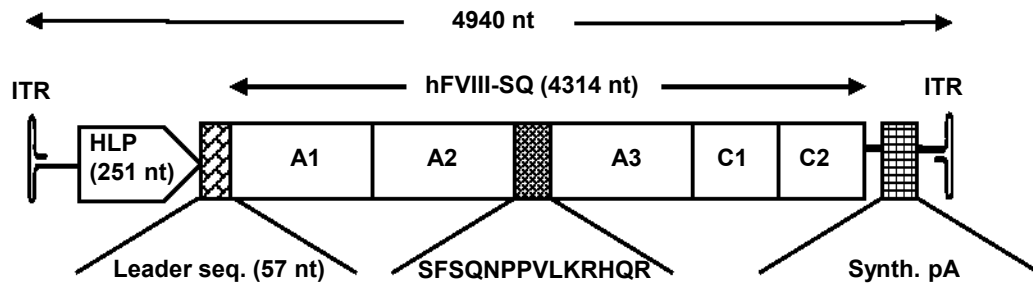

Legend –Note that schematic is not to scale; nt = nucleotides

BMN 270 will be delivered by a single intravenous dose and is designed to achieve stable, potentially life-long expression of active hFVIII in the plasma, synthesized from vector-transduced liver tissue.

BMN 270 is currently being evaluated in clinical study 270-201, an ongoing first-in-human, phase 1/2 dose escalation study in subjects with severe HA designed to assess the safety and efficacy of BMN 270 at various dose levels (6E12 vg/kg, 2E13 vg/kg, 4E13 vg/kg, 6E13 vg/kg). Specifically, 270-201 explores the relationship of vector dose to the augmentation of residual FVIII activity and whether these levels are sufficient to alter the clinical phenotype. Preliminary results from 270-201 have demonstrated that following gene transfer, FVIII activity above 15% (15 IU/dL) and, in many cases, within the normal range for FVIII, is achievable with a dose of 4-6E13 vg/kg with an acceptable safety profile (Pasi, 2017, *Blood*). For additional information on preliminary data in 270-201, refer to the current version of the Investigator's Brochure.





The current study is a Phase 3, single-arm, open-label study designed to assess whether, in an expanded sample, BMN 270 can safely alter the clinical phenotype of hemophilia A patients with residual FVIII activity  $\leq 1$  IU/dL, with an altered phenotype defined as reaching FVIII activity of  $\geq 15\%$  ( $\geq 15$  IU/ dL).

#### 7.4 Summary of Overall Risks and Benefits

The majority of subjects in the ongoing 270-201 clinical study who have received 4E13 or 6E13 vg/kg doses of BMN 270 have had Grade 1 asymptomatic elevations in ALT. For most subjects, the elevations have reached only slightly above the ULN. Based on the effectiveness of transient oral corticosteroid used to suppress a presumed cytotoxic T-cell response in prior studies with hepatic transduction with AAV vectors (Mingozzi, 2013), subjects were treated with 7-32 weeks of oral corticosteroids preventatively or in response to the elevations in ALT to ensure preservation of the transduced hepatocytes. Using this approach, no sustained loss of FVIII activity has been observed in subjects with ALT elevations, consistent with maintaining a high level of hepatocyte function. Moreover, the rise in ALT levels were not accompanied by significant or lasting aberrations in other liver function tests such as AST, bilirubin or albumin, indicating that extent of toxicity is limited. Overall, the literature suggests that transient elevations in liver enzymes are expected following AAV-based gene therapy for the treatment for hemophilia B without any long-term concerns of hepatic injury (Manno, 2006, *Nature Med*); (Nathwani, 2011, *N Engl J Med*); (George, 2016, *Haemophilia*); (Miesbach, 2016, *Haemophilia*).

At the highest dose tested in 270-201 (6E13 vg/kg), the majority of subjects achieved FVIII levels above 50 IU/dL at 52 weeks post-infusion. Subjects in that cohort also reported markedly decreased bleeding compared with pre-study rates and the ability to discontinue prophylactic FVIII infusions. Subjects at all dose levels continue to be followed.

The current data available for BMN 270 does not yet permit adequate assessment of the benefit:risk profile of this investigational drug. Given the monitoring measures in place in the clinical protocol(s) to minimize the risk to subjects participating in the existing studies, the identified risks are justified by the anticipated benefits that may be afforded to subjects. Each subject in 270-301 will have a comprehensive surveillance plan that monitors LFTs during the study, and elevations in LFT will be addressed according to the guidelines set forth in the protocol. Safety will be assessed by adverse event reporting and clinical laboratory assessments.

For additional information on findings in 270-201, refer to the current version of the Investigator's Brochure.



## 8 STUDY OBJECTIVES

The primary efficacy objective of the study is to:

- Assess the efficacy of BMN 270 defined as FVIII activity, as measured by one-stage clotting assay, during Weeks 49-52 following intravenous infusion of BMN 270

The secondary efficacy objectives of the study are to:

- Assess the impact of BMN 270 on usage of exogenous FVIII replacement therapy from Week 5 to Week 52
- Assess the impact of BMN 270 on the number of bleeding episodes requiring exogenous FVIII replacement therapy from Week 5 to Week 52

The tertiary efficacy objective of the study is to:

- Assess the impact of BMN 270 on patient-reported outcomes (PROs) at Week 52 of the study compared to baseline

The safety objectives of the study are to:

- Evaluate the safety of BMN 270 during the first 52 weeks following intravenous infusion
- Assess the long-term safety of BMN 270



## 9 INVESTIGATIONAL PLAN

### 9.1 Overall Study Design and Plan

This is a Phase 3, single-arm, open-label study in hemophilia A patients with residual FVIII levels  $\leq 1$  IU/dL treated continuously with prophylactic exogenous FVIII for a minimum of one year prior to enrollment. Subjects will be enrolled at approximately 40 sites worldwide. Subjects must have high-quality, well-documented historical data available concerning previous bleeding episodes and exogenous FVIII usage over the previous 12 months in order to be eligible to enroll in the study.

Approximately 70 adult subjects with severe HA will receive a 6E13 vg/kg dose of BMN 270 as a single intravenous infusion. Approximately 20 subjects will enroll in the study with at least 12 months of well-documented high-quality historical data concerning previous bleeding episodes and exogenous FVIII usage, while approximately 50 subjects will enroll in the study after having completed at least 6 months' participation in the BioMarin-sponsored non-interventional study 270-902.

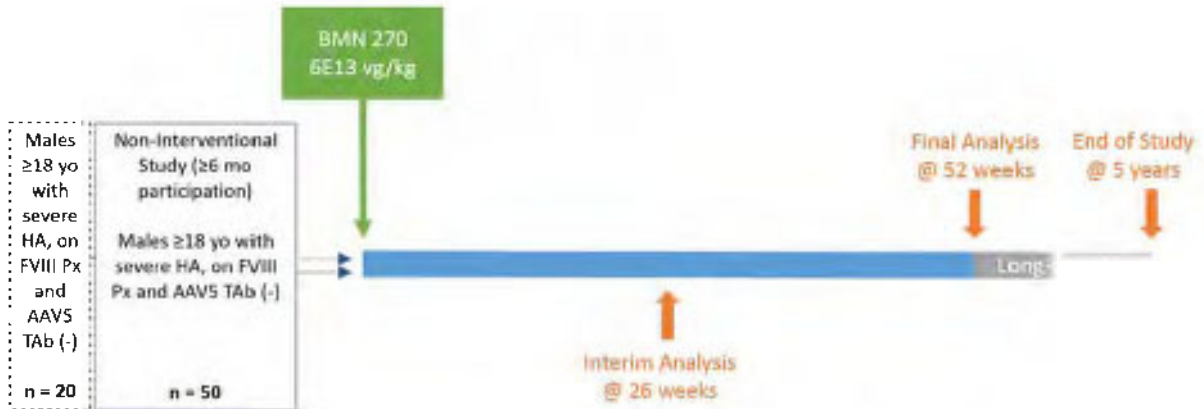

yo = years old, HA = hemophilia A, FVIII = factor VIII, Px = prophylaxis, AAV5 = adeno-associated virus, serotype 5, TAB = total antibody, mo = month, vg = vector genomes, kg = kilogram, f/u = follow-up

The Data Monitoring Committee (DMC) will review available safety and efficacy (eg, FVIII activity) data during the study on an ongoing basis and may determine, based on emerging data and the risk/benefit profile, that further enrollment at 6E13 vg/kg should be discontinued in favor of a different dose of BMN 270, not to exceed 6E13 vg/kg. If the DMC recommends a dosing modification, then additional subjects may be enrolled, up to a total of approximately 70 subjects, at the new BMN 270 dose level (regardless of the number of subjects previously enrolled at 6E13 vg/kg).

An interim analysis is planned after 20 treated subjects have completed the Week 26 visit.



The final analysis for the study will be performed after all subjects have been followed for 52 weeks post-BMN 270 infusion. After the final analysis, safety and efficacy will then continue to be assessed long-term in all subjects for a total of approximately 5 years.

To avoid breakthrough bleeding, subjects will only discontinue exogenous prophylactic FVIII replacement therapy after FVIII activity has reached at least 5 IU/dL or 4 weeks following infusion of BMN 270, whichever is earlier. Four weeks represents the time by which endogenous production of FVIII following gene transfer is expected to be efficacious.

Throughout the study, subjects with FVIII activity below 5 IU/dL may be monitored more frequently at the discretion of the Medical Monitor and the Investigator. In subjects who show an initial response to BMN 270 but who later have FVIII activity decline to < 5 IU/dL, the investigator and medical monitor will review the subject's FVIII activity levels and discuss whether to resume prior FVIII prophylaxis. In addition, the investigator will notify the subject of his FVIII activity levels and will discuss with the subject the risk of bleeding and when (and if) prior FVIII prophylaxis will be resumed.

There will be an ongoing review of individual subject safety and efficacy data by the Medical Monitor and the DMC. FVIII activity by a validated assay will be used to evaluate efficacy over the course of the study. Therapeutic oral corticosteroids may be initiated when a subject's ALT values are elevated or based on review of FVIII activity and liver enzyme data, and subsequent dosage adjustments made, after consultation between the Investigator and the Medical Monitor. Management of ALT elevations is discussed in more detail in Section 9.7.8.3.

Any safety signal may trigger a review of the data and possible additional immunogenicity studies or other diagnostics deemed necessary that include an assessment of cellular immune responses using collected peripheral blood mononuclear cells (PBMCs).

Schedules of assessments for the Screening and Infusion period (Table 9.1.1), Post-Infusion follow-up periods (Table 9.1.2, Table 9.1.3, Table 9.1.4), and during the use of oral corticosteroids (Table 9.1.5) are presented below.

**Table 9.1.1: Schedule of Events – Screening and Infusion**

| Assessment  | Prior to BMN 270 Infusion                  |  |  | BMN 270 Infusion Visit (Day 1) <sup>k</sup> |
|---|--|--|--|---|
|   | Screening <sup>*</sup> (Day -28 to Day -1) | Smart Rescreening <sup>i</sup> (Day -28 to Day -1) | Baseline (Day -7 to Day -1) <sup>h</sup> |   |
| Informed consent  | X  |  |  |   |
| Demographics (age, sex, race, ethnicity)  | X  |  |  |   |
| Medical History   | X  |  |  |   |
| Physical Examination <sup>a</sup>   | X  |  | X  | X   |
| Height and Weight   | X  |  |  |   |
| Vital Signs   | X  | X  | X  | X   |
| Assessment of Adverse Events and Concomitant Medications  | X  | X  | X  | X   |
| Documentation of bleeding episodes and FVIII usage for previous 12 months (by either subject or clinical information) | X  | X  | X  |   |
| Distribution of subject diaries and training in their use <sup>l</sup>  | X  |  |  |   |
| Electrocardiogram   | X  |  |  |   |
| Liver Ultrasound  | X  |  |  |   |
| hFVIII Assays <sup>b</sup>  | X  | X <sup>j</sup>                                     | X  |   |
| AAV5 TAb Assays <sup>c</sup>  | X  | X  | X  | X   |
| AAV5 TI Assay   |  |  | X  |   |
| Screen for Hepatitis B, Hepatitis C, HIV <sup>d</sup>   | X  |  |  |   |
| Blood chemistry, hematology, and coagulation tests <sup>e</sup>   | X  | X  | X  |   |
| Fasting lipid panel (blood triglycerides, total cholesterol, HDL cholesterol, and LDL cholesterol)                    |  |  |  | X   |
| Urine Tests <sup>e</sup>  | X  | X  | X  |   |
| Liver Function Tests <sup>e</sup>   | X  | X  | X  |   |



| Assessment  | Prior to BMN 270 Infusion      |  |  | BMN 270 Infusion Visit (Day 1) <sup>k</sup> |
|---|--------------------------------|--|--|---|
|   | Screening* (Day -28 to Day -1) | Smart Rescreening <sup>i</sup> (Day -28 to Day -1) | Baseline (Day -7 to Day -1) <sup>h</sup> |   |
| PBMC collection (for baseline determination of AAV5 and FVIII specific cellular immunity) |                                |  | X  |   |
| Von Willebrand Factor Antigen (VWF:Ag)  |                                |  | X  |   |
| Direct Thrombin Activity Test <sup>e</sup>  |                                |  | X  |   |
| TGA Assay <sup>g</sup>  |                                |  | X  |   |
| PCR of vector DNA in blood, saliva, urine, semen, and stools                              |                                |  | X  | X   |
| Biomarker testing <sup>f</sup>  | X                              |  |  |   |
| Exploratory biomarker assessments <sup>g</sup>  |                                |  | X  |   |
| Haemo-QOL-A assessment  |                                |  | X  |   |
| EQ-5D-5L  |                                |  | X  |   |
| HAL   |                                |  | X  |   |
| WPAI+CIQ:HS   |                                |  | X  |   |
| PROBE   |                                |  | X  |   |
| BMN 270 Infusion  |                                |  |  | X   |

\* Screening assessments should be performed within 28 days of BMN 270 infusion (and must be performed within 42 days prior to BMN 270 infusion).

<sup>a</sup> Complete physical examination should be done at Screening. Brief physical examination may be done at Baseline and at the BMN 270 Infusion Visit.

<sup>b</sup> Includes baseline FVIII activity (chromogenic FVIII assay and one-stage clot FVIII assay), coagulation exploratory assay, hFVIII inhibitor level (Bethesda assay with Nijmegen modification), hFVIII total antibody titer, and hFVIII protein assay. Baseline activity should be assessed at trough (at least >72 hours after last dose of replacement FVIII therapy, or 5x the known half-life of the FVIII concentrates administered).

<sup>c</sup> Sample collection on the day of the infusion visit must be performed before the BMN 270 infusion is given. Screening, Smart Re-screening, and Infusion Day samples will be tested in an AAV5 Tab pre-screening assay specifically developed for enrolment purposes. Baseline and all post-dose samples will be tested in a different AAV5 Tab post-dose immunogenicity monitoring assay

<sup>d</sup> Patients with documented negative results within the last 30 days do not need to be retested.

<sup>e</sup> Refer to [Table 9.7.8.2.1](#) for laboratory assessments to be included, and to [Table 9.7.8.3.1](#) for liver function tests.



- 
- <sup>f</sup> Includes HLA genotyping and FVIII genotyping.
- <sup>g</sup> Blood samples will be collected to evaluate biochemical, molecular, cellular, and genetic/genomic aspects relevant to hemophilia A, coagulation, and/or AAV gene transfer, and to develop assays used for these evaluations. Subjects may choose to opt out of the exploratory genetic/genomic research being done to study or try to discover genes that are not yet known to be associated with hemophilia A. While exploratory samples will be collected at the time points indicated above, testing of these samples (including those for TGA assay, Direct Thrombin Activity test, and any other exploratory assessments) will be performed only as deemed necessary by the Sponsor.
- <sup>h</sup> Should the screening visit occur within 30 days of the drug infusion, physical examination, blood chemistry, LFTs, hematology, urine tests, and coagulation tests do not need to be repeated at Baseline.
- <sup>i</sup> Smart rescreening should only be performed if a patient has been determined to be eligible for the study and is unable to complete the Baseline assessments and Infusion prior to the closing of the original Screening window. Subjects who undergo smart rescreening must complete the rescreening assessments and receive the infusion within 90 days of signing the original consent. Subjects who do not complete dosing within 90 days will be required to re-consent and undergo all screening procedures. Subjects may not undergo smart rescreening more than once.
- <sup>j</sup> Only the hFVIII inhibitor level (Bethesda assay with Nijmegen modification) assay must be done at smart rescreening.
- <sup>k</sup> With the exception of the collection of samples for PCR vector DNA analysis, assessments on the day of infusion must be performed prior to the infusion. On the day of the BMN 270 Infusion, vital signs will be monitored prior to the infusion, during the infusion every 15 minutes ( $\pm$  5 minutes), and following the infusion hourly ( $\pm$  5 minutes) for at least 8 hours during the subject's stay in the clinic. Shedding samples for PCR of vector DNA analysis (blood, saliva, urine, semen, stool) should be collected between 2 and 24 hours after the infusion has been completed.
- <sup>l</sup> Diaries should be distributed to subjects who have consented to participate in the study and who have been determined to meet all study eligibility criteria.

**Table 9.1.2: Schedule of Events – Post-Infusion Follow-Up (Week 1-16)**

| Assessment  | Follow-Up After BMN 270 Infusion – Weeks* |    |    |    |    |    |    |    |    |    |    |    |    |    |    |     |     |
|---|---|----|----|----|----|----|----|----|----|----|----|----|----|----|----|-----|-----|
|   | Week 1                                    |    | 2  | 3  | 4  | 5  | 6  | 7  | 8  | 9  | 10 | 11 | 12 | 13 | 14 | 15  | 16  |
|   | D4  | D8 |    |    |    |    |    |    |    |    |    |    |    |    |    |     |     |
| Study Day*  | 4   | 8  | 15 | 22 | 29 | 36 | 43 | 50 | 57 | 64 | 71 | 78 | 85 | 92 | 99 | 106 | 113 |
| Physical examination <sup>a</sup>   |   | X  | X  | X  | X  | X  | X  | X  | X  | X  | X  | X  | X  | X  | X  | X   | X   |
| Weight <sup>a</sup>   |   |    |    |    | X  |    |    |    | X  |    |    |    | X  |    |    |     | X   |
| Assessment of Adverse Events and Concomitant Medications (including review of subject diary for bleeding and FVIII use) |   | X  | X  | X  | X  | X  | X  | X  | X  | X  | X  | X  | X  | X  | X  | X   | X   |
| Vital Signs   |   | X  | X  | X  | X  | X  | X  | X  | X  | X  | X  | X  | X  | X  | X  | X   | X   |
| Blood chemistry, hematology, and coagulation tests <sup>b</sup>   |   |    | X  |    | X  |    |    |    |    |    | X  |    |    |    |    |     | X   |
| Urine Tests <sup>b</sup>  |   |    |    |    |    |    |    |    |    |    |    |    | X  |    |    |     |     |
| Liver Function Tests <sup>b</sup>   | X   | X  | X  | X  | X  | X  | X  | X  | X  | X  | X  | X  | X  | X  | X  | X   | X   |
| FVIII assays <sup>c</sup>   |   | X  | X  | X  | X  | X  | X  | X  | X  | X  | X  | X  | X  | X  | X  | X   | X   |
| FVIII antibody titer  |   |    |    |    | X  |    |    |    | X  |    |    |    | X  |    |    |     | X   |
| PCR of vector DNA in blood, saliva, urine, semen, and stools <sup>d</sup>   | X   | X  | X  | X  | X  |    | X  |    | X  |    |    |    | X  |    |    |     | X   |
| Exploratory biomarker assessments <sup>c</sup>  |   |    |    |    |    |    | X  |    |    |    |    |    |    | X  |    |     | X   |
| Haemo-QOL-A assessment  |   |    |    |    | X  |    |    |    |    |    |    |    | X  |    |    |     |     |
| EQ-5D-5L  |   |    |    |    | X  |    |    |    |    |    |    |    | X  |    |    |     |     |



| Assessment  | Follow-Up After BMN 270 Infusion – Weeks* |    |    |    |    |    |    |    |    |    |    |    |    |    |    |     |                |
|---|---|----|----|----|----|----|----|----|----|----|----|----|----|----|----|-----|----------------|
|   | Week 1                                    |    | 2  | 3  | 4  | 5  | 6  | 7  | 8  | 9  | 10 | 11 | 12 | 13 | 14 | 15  | 16             |
|   | D4  | D8 |    |    |    |    |    |    |    |    |    |    |    |    |    |     |                |
| Study Day*  | 4   | 8  | 15 | 22 | 29 | 36 | 43 | 50 | 57 | 64 | 71 | 78 | 85 | 92 | 99 | 106 | 113            |
| HAL   |   |    |    |    | X  |    |    |    |    |    |    |    | X  |    |    |     |                |
| WPAI+CIQ:HS   |   |    |    |    | X  |    |    |    |    |    |    |    | X  |    |    |     |                |
| PROBE   |   |    |    |    | X  |    |    |    |    |    |    |    | X  |    |    |     |                |
| AAV5 Tab Assay  |   |    |    |    |    |    |    |    | X  |    |    |    |    |    |    |     | X              |
| AAV5 TI Assay   |   |    |    |    |    |    |    |    | X  |    |    |    |    |    |    |     | X              |
| Testing for reactivation of hepatitis B and hepatitis C                 |   |    |    |    |    |    |    |    |    |    |    |    |    |    |    |     | X <sup>f</sup> |
| PBMC collection (for determination of AAV5 and FVIII specific immunity) |   |    | X  |    | X  |    | X  |    | X  |    | X  |    | X  |    | X  |     | X              |
| VWF:Ag  |   |    |    |    |    |    |    |    |    |    |    |    |    | X  |    |     |                |
| Direct Thrombin Activity test <sup>c</sup>                              |   |    |    |    |    |    |    |    |    |    |    |    |    | X  |    |     |                |

\* Visit windows are ± 48 hours (and include the Day 4 visit).

<sup>a</sup> Brief physical examination should be done at all weekly visits.

<sup>b</sup> Refer to [Table 9.7.8.2.1](#) for laboratory assessments to be included, and to [Table 9.7.8.3.1](#) for liver function tests. LFTs may be monitored more or less frequently (and in particular when ALT values are >1.5x ULN) based on discussion between the Medical Monitor and the Investigator and review of subject data, but LFTs will be monitored at least twice weekly during periods when a subject's ALT is ≥ 3x ULN. Subjects with ALT > 1.5x ULN during the study and either an alternative etiology considered or for further evaluation of the lab abnormality may undergo additional evaluations (eg, imaging studies including MRI or ultrasound, additional blood tests, and/or liver biopsy) at the discretion of the Investigator. Additional testing of FVIII and LFTs during any study week may be performed if: (1) the ALT has increased to above ULN; (2) Increases in ALT values from prior assessment are accompanied by declines in FVIII activity level; or after a discussion between the Medical Monitor and the Investigator based on a review of subject data. If FVIII levels and/or ALT values are stable over the course of several weeks, assessment of FVIII activity and liver enzymes may be adjusted based on discussion between the Medical Monitor and the Investigator.

<sup>c</sup> Includes FVIII activity level (chromogenic FVIII assay and one-stage clot FVIII assay), Bethesda assay (with Nijmegen modification) for hFVIII inhibitor level, coagulation exploratory assay, and hFVIII protein assay. If a subject has used FVIII within 72 hours of a measurement day, all efforts should be made to obtain FVIII activity measurements when a 72-hour interval without FVIII use is achieved; the 72-hour wash-out period is only intended for subjects who have achieved FVIII ≥ 5 IU/dL at 16 weeks after BMN 270 infusion and who have



---

not resumed FVIII replacement therapy. If FVIII levels are elevated or stable over the course of several weeks, assessment of FVIII activity may be adjusted based on discussion between the Medical Monitor and the Investigator. A D-dimer may be considered under circumstances in which FVIII activity levels are above the normal physiological range and/or if there is a concern for a venous thromboembolism.

- <sup>d</sup> Collection for each matrix to occur until at least 3 consecutive negative results are obtained. Collection and testing of semen samples must continue at least through Week 12, even if 3 consecutive negative results in that compartment have already been recorded.
- <sup>e</sup> Blood samples will be collected to evaluate biochemical, molecular, cellular, and genetic/genomic aspects relevant to hemophilia A, coagulation, and/or AAV gene transfer, and to develop assays used for these evaluations. Subjects may choose to opt out of the exploratory genetic/genomic research being done to study or try to discover genes that are not yet known to be associated with hemophilia A. While exploratory samples will be collected at the time points indicated above, testing of these samples (including those for TGA assay, Direct Thrombin Activity test, and any other exploratory assessments) will be performed only as deemed necessary by the Sponsor.
- <sup>f</sup> Testing for reactivation of hepatitis B and hepatitis C at Week 16 should be performed only in subjects with evidence of prior exposure and who have not received therapeutic oral corticosteroids prior to Week 16; subjects who have received therapeutic oral corticosteroids will have hepatitis B and hepatitis C testing at the time points indicated in [Table 9.1.5](#).



**Table 9.1.3: Schedule of Events – Post-Infusion Follow-Up (Week 17-32)**

| Assessment  | Follow-Up After BMN 270 Infusion – Weeks* |     |     |     |     |     |     |     |     |     |     |     |     |     |     |     |
|---|---|-----|-----|-----|-----|-----|-----|-----|-----|-----|-----|-----|-----|-----|-----|-----|
|   | 17  | 18  | 19  | 20  | 21  | 22  | 23  | 24  | 25  | 26  | 27  | 28  | 29  | 30  | 31  | 32  |
| Study Day*  | 120                                       | 127 | 134 | 141 | 148 | 155 | 162 | 169 | 176 | 183 | 190 | 197 | 204 | 211 | 218 | 225 |
| Physical examination <sup>a</sup>   | X   | X   | X   | X   | X   | X   | X   | X   | X   | X   | X   | X   | X   | X   | X   | X   |
| Weight <sup>a</sup>   |   |     |     | X   |     |     |     | X   |     |     |     | X   |     |     |     | X   |
| Assessment of Adverse Events and Concomitant Medications (including review of subject diary for bleeding and FVIII use) | X   | X   | X   | X   | X   | X   | X   | X   | X   | X   | X   | X   | X   | X   | X   | X   |
| Vital Signs   | X   | X   | X   | X   | X   | X   | X   | X   | X   | X   | X   | X   | X   | X   | X   | X   |
| Blood chemistry, hematology, and coagulation tests <sup>b</sup>   |   |     |     |     |     | X   |     |     |     | X   |     |     |     |     |     | X   |
| Urine Tests <sup>b</sup>  |   |     |     |     |     |     |     |     |     | X   |     |     |     |     |     |     |
| Liver Function Tests <sup>b</sup>   | X   | X   | X   | X   | X   | X   | X   | X   | X   | X   | X   | X   | X   | X   | X   | X   |
| FVIII assays <sup>c</sup>   | X   | X   | X   | X   | X   | X   | X   | X   | X   | X   | X   | X   | X   | X   | X   | X   |
| FVIII antibody titer  |   |     |     | X   |     |     |     | X   |     | X   |     |     |     |     |     | X   |
| PCR of vector DNA in blood, saliva, urine, semen, and stools <sup>d</sup>   |   |     |     | X   |     |     |     | X   |     | X   |     |     |     |     |     | X   |
| Exploratory biomarker assessments <sup>e</sup>  |   |     |     | X   |     |     |     | X   |     | X   |     |     |     |     |     | X   |



| Assessment   | Follow-Up After BMN 270 Infusion – Weeks* |     |     |     |     |     |     |     |     |     |     |     |     |     |     |     |
|--|---|-----|-----|-----|-----|-----|-----|-----|-----|-----|-----|-----|-----|-----|-----|-----|
|  | 17  | 18  | 19  | 20  | 21  | 22  | 23  | 24  | 25  | 26  | 27  | 28  | 29  | 30  | 31  | 32  |
| Study Day*   | 120                                       | 127 | 134 | 141 | 148 | 155 | 162 | 169 | 176 | 183 | 190 | 197 | 204 | 211 | 218 | 225 |
| Haemo-QOL-A assessment   |   |     |     |     |     |     |     |     |     | X   |     |     |     |     |     |     |
| EQ-5D-5L   |   |     |     |     |     |     |     |     |     | X   |     |     |     |     |     |     |
| HAL  |   |     |     |     |     |     |     |     |     | X   |     |     |     |     |     |     |
| WPAI+CIQ:HS  |   |     |     |     |     |     |     |     |     | X   |     |     |     |     |     |     |
| PROBE  |   |     |     |     |     |     |     |     |     | X   |     |     |     |     |     |     |
| AAV5 TAb Assay   |   |     |     |     |     |     |     | X   |     |     |     |     |     |     |     | X   |
| AAV5 TI Assay  |   |     |     |     |     |     |     | X   |     |     |     |     |     |     |     | X   |
| PBMC collection (for determination of AAV5 and FVIII specific cellular immunity) |   | X   |     | X   |     | X   |     | X   |     | X   |     | X   |     | X   |     | X   |
| VWF:Ag   |   |     |     |     |     |     |     |     |     | X   |     |     |     |     |     |     |
| Direct Thrombin Activity Test <sup>c</sup>                                       |   |     |     |     |     |     |     |     |     | X   |     |     |     |     |     |     |
| TGA Assay <sup>c</sup>   |   |     |     | X   |     |     |     | X   |     | X   |     |     |     |     |     | X   |

\* Visit windows are  $\pm$  48 hours.

<sup>a</sup> Brief physical examination should be done at all weekly visits except Week 26, where a complete physical examination should be performed. Weight should be recorded at Week 20 and every 4 weeks.

<sup>b</sup> Refer to [Table 9.7.8.2.1](#) for laboratory assessments to be included, and to [Table 9.7.8.3.1](#) for liver function tests. LFTs may be monitored more or less frequently (and in particular when ALT values are  $>1.5x$  ULN) based on discussion between the Medical Monitor and the Investigator and review of subject data, but LFTs will be monitored at least twice weekly during periods when a subject's ALT is  $\geq 3x$  ULN. Subjects with ALT  $> 1.5x$  ULN during the study and either an alternative etiology considered or for further evaluation of the lab abnormality may undergo additional evaluations (eg, imaging studies including MRI or ultrasound, additional blood tests, and/or liver biopsy) at the discretion of the Investigator. Additional testing of FVIII and LFTs during any study week may be performed if: (1) the ALT has increased to above ULN; (2) Increases in ALT values from prior assessment are accompanied by declines in



---

FVIII activity level; or after a discussion between the Medical Monitor and the Investigator based on a review of subject data. If FVIII levels and/or ALT values are stable over the course of several weeks, assessment of FVIII activity and liver enzymes may be adjusted based on discussion between the Medical Monitor and the Investigator.

<sup>c</sup> Includes FVIII activity level (chromogenic FVIII assay and one-stage clot FVIII assay), Bethesda assay (with Nijmegen modification) for hFVIII inhibitor level, coagulation exploratory assay, and hFVIII protein. If a subject has used FVIII within 72 hours of a measurement day, all efforts should be made to obtain FVIII activity measurements when a 72-hour interval without FVIII use is achieved; the 72-hour wash-out period is only intended for subjects who have achieved FVIII  $\geq 5$  IU/dL at 16 weeks after BMN 270 infusion and who have not resumed FVIII replacement therapy. If FVIII levels are elevated or stable over the course of several weeks, assessment of FVIII activity may be adjusted based on discussion between the Medical Monitor and the Investigator. A D-dimer may be considered under circumstances in which FVIII activity levels are above the normal physiological range and/or if there is a concern for a venous thromboembolism.

<sup>d</sup> Collection for each matrix to occur until at least 3 consecutive negative results are obtained.

<sup>e</sup> Blood samples will be collected to evaluate biochemical, molecular, cellular, and genetic/genomic aspects relevant to hemophilia A, coagulation, and/or AAV gene transfer, and to develop assays used for these evaluations. Subjects may choose to opt out of the exploratory genetic/genomic research being done to study or try to discover genes that are not yet known to be associated with hemophilia A. While exploratory samples will be collected at the time points indicated above, testing of these samples (including those for TGA assay, Direct Thrombin Activity test, and any other exploratory assessments) will be performed only as deemed necessary by the Sponsor.

**Table 9.1.4: Schedule of Events – Post-Infusion Follow-Up (Week 33 – Year 5)**

| Assessment  | Year 1 – Weeks* |     |     |     |     |     |     |     |     |     |     |     | Years 2-5*       | Year 2* | Years 3-5* | ETV |
|---|-----------------|-----|-----|-----|-----|-----|-----|-----|-----|-----|-----|-----|------------------|---------|------------|-----|
|   | 33              | 34  | 35  | 36  | 38  | 40  | 42  | 44  | 46  | 48  | 50  | 52  | Q3M              | Q4W     | Q6W        |     |
| Study Day*  | 232             | 239 | 246 | 253 | 267 | 281 | 295 | 309 | 323 | 337 | 351 | 365 |                  |         |            |     |
| Physical examination <sup>a</sup>   | X               | X   | X   | X   | X   | X   | X   | X   | X   | X   | X   | X   | X <sup>a</sup>   |         |            | X   |
| Weight <sup>a</sup>   |                 |     |     | X   |     | X   |     | X   |     | X   |     | X   | X <sup>a</sup>   |         |            | X   |
| Assessment of Adverse Events and Concomitant Medications (including review of subject diary for bleeding and FVIII use) | X               | X   | X   | X   | X   | X   | X   | X   | X   | X   | X   | X   | X                |         |            | X   |
| Vital Signs   | X               | X   | X   | X   | X   | X   | X   | X   | X   | X   | X   | X   | X                |         |            | X   |
| Blood chemistry, hematology, and coagulation tests <sup>b</sup>   |                 |     |     | X   |     |     |     | X   |     |     |     | X   | X <sup>b</sup>   |         |            | X   |
| Urine Tests <sup>b</sup>  |                 |     |     |     | X   |     |     |     |     |     |     | X   | X <sup>b</sup>   |         |            | X   |
| Liver Function Tests <sup>b</sup>   | X               | X   | X   | X   | X   | X   | X   | X   | X   | X   | X   | X   |                  | X       | X          | X   |
| FVIII assays <sup>c</sup>   | X               | X   | X   | X   | X   | X   | X   | X   | X   | X   | X   | X   |                  | X       | X          | X   |
| AAV5 TAb Assay  |                 |     |     | X   |     |     |     |     |     |     |     | X   | X                |         |            | X   |
| AAV5 TI Assay   |                 |     |     | X   |     |     |     |     |     |     |     | X   | X                |         |            | X   |
| FVIII antibody titer  |                 |     |     | X   |     |     |     | X   |     |     |     | X   | X                |         |            | X   |
| Exploratory biomarker assessments <sup>c</sup>  |                 |     |     | X   |     | X   |     | X   |     | X   |     | X   | X                |         |            | X   |
| PBMC Collection (for determination of FVIII and Capsid specific cellular immunity)                                      |                 | X   |     | X   |     |     |     | X   |     |     |     | X   | X                |         |            | X   |
| VWF:Ag  |                 |     |     |     | X   |     |     |     |     |     |     | X   | X                |         |            | X   |
| Direct Thrombin Activity Test <sup>c</sup>  |                 |     |     |     | X   |     |     |     |     |     |     | X   | X                |         |            | X   |
| TGA Assay <sup>c</sup>  |                 |     |     | X   |     | X   |     | X   |     | X   |     | X   | X                |         |            | X   |
| PCR of vector DNA in blood, saliva, urine, semen, and stools <sup>d</sup>   |                 |     |     | X   |     | X   |     | X   |     | X   |     | X   | (X) <sup>d</sup> |         |            | X   |



| Assessment             | Year 1 – Weeks* |     |     |     |     |     |     |     |     |     |     |     | Years 2-5*     | Year 2* | Years 3-5* | ETV |
|------------------------|-----------------|-----|-----|-----|-----|-----|-----|-----|-----|-----|-----|-----|----------------|---------|------------|-----|
|                        | 33              | 34  | 35  | 36  | 38  | 40  | 42  | 44  | 46  | 48  | 50  | 52  | Q3M            | Q4W     | Q6W        |     |
| Study Day*             | 232             | 239 | 246 | 253 | 267 | 281 | 295 | 309 | 323 | 337 | 351 | 365 |                |         |            |     |
| Haemo-QOL-A assessment |                 |     |     |     |     |     |     |     |     |     |     | X   | X <sup>f</sup> |         |            | X   |
| EQ-5D-5L               |                 |     |     |     |     |     |     |     |     |     |     | X   | X <sup>f</sup> |         |            | X   |
| HAL                    |                 |     |     |     |     |     |     |     |     |     |     | X   | X <sup>f</sup> |         |            | X   |
| WPAI+CIQ:HS            |                 |     |     |     |     |     |     |     |     |     |     | X   | X <sup>f</sup> |         |            | X   |
| PROBE                  |                 |     |     |     |     |     |     |     |     |     |     | X   | X <sup>f</sup> |         |            | X   |

\* Visit windows are  $\pm$  48 hours through Week 36, then  $\pm$  1 week until Week 52 and  $\pm$  2 weeks for visits in Years 2-5. For LFT and FVIII testing during Years 2-5, the visit windows are every 4 weeks (+ 2 weeks, or to align with the Q3M visits) during Year 2, and every 6 weeks ( $\pm$  2 weeks) during Years 3-5.

<sup>a</sup> Complete physical examination should be performed at Week 52 and every 52 weeks thereafter; brief physical exam may be performed at other study visits. Weight should be recorded at Week 36 and every 4 weeks through Week 52, then every 6 months during Years 2-5.

<sup>b</sup> Refer to [Table 9.7.8.2.1](#) for laboratory assessments to be included, and to [Table 9.7.8.3.1](#) for liver function tests. LFTs may be monitored more or less frequently (and in particular when ALT values are  $>1.5x$  ULN) based on discussion between the Medical Monitor and the Investigator and review of subject data, but LFTs will be monitored at least twice weekly during periods when a subject's ALT is  $\geq 3x$  ULN. Subjects with ALT  $> 1.5x$  ULN during the study and either an alternative etiology considered or for further evaluation of the lab abnormality may undergo additional evaluations (eg, imaging studies including MRI or ultrasound, additional blood tests, and/or liver biopsy) at the discretion of the Investigator. Additional testing of FVIII and LFTs during any study week may be performed if: (1) the ALT has increased to above ULN or increased by  $> 10$  U/L from prior assessment; (2) Increases in ALT values from prior assessment are accompanied by declines in FVIII activity level; or after a discussion between the Medical Monitor and the Investigator based on a review of subject data. If FVIII levels and/or ALT values are stable over the course of several weeks, assessment of FVIII activity and liver enzymes may be adjusted based on discussion between the Medical Monitor and the Investigator. During Years 2-5 of the Post-Infusion Follow-Up period, urine tests and blood, chemistry, and coagulation tests should be performed every 6 months (starting with Week 78).

<sup>c</sup> Includes FVIII activity level (chromogenic FVIII assay and one-stage clot FVIII assay), Bethesda assay (with Nijmegen modification) for hFVIII inhibitor level, coagulation exploratory assay, and hFVIII protein assay. If a subject has used FVIII within 72 hours of a measurement day, all efforts should be made to obtain FVIII activity measurements when a 72-hour interval without FVIII use is achieved; the 72-hour wash-out period is only intended for subjects who have achieved FVIII  $\geq 5$  IU/dL at 16 weeks after BMN 270 infusion and who have not resumed FVIII replacement therapy. If FVIII levels are elevated or stable over the course of several weeks, assessment of FVIII activity may be adjusted based on discussion between the Medical Monitor and the Investigator. A D-dimer may be considered under circumstances in which FVIII activity levels are above the normal physiological range and/or if there is a concern for a venous thromboembolism. If a subject tests positive in the Bethesda assay (with Nijmegen modification) during Years 3-5, a fresh sample should be collected within 4 weeks of the initial visit that had a positive result.



- 
- <sup>d</sup> Sample testing during Long-Term Follow-Up is not required if at least 3 consecutive samples were negative during the Post-Infusion Follow-Up period. Subjects who have not had 3 consecutive negative semen samples by Week 52 should continue to have PCR testing of semen every 4 weeks until 3 consecutive negative samples are documented (or upon consultation between the Investigator and Medical Monitor).
- <sup>e</sup> Blood samples will be collected to evaluate biochemical, molecular, cellular, and genetic/genomic aspects relevant to hemophilia A, coagulation, and/or AAV gene transfer, and to develop assays used for these evaluations. Subjects may choose to opt out of the exploratory genetic/genomic research being done to study or try to discover genes that are not yet known to be associated with hemophilia A. While exploratory samples will be collected at the time points indicated above, testing of these samples (including those for TGA assay, Direct Thrombin Activity test, and any other exploratory assessments) will be performed only as deemed necessary by the Sponsor.
- <sup>f</sup> PRO assessments during Years 2-5 of Long-Term Follow-up should be performed at every other visit (every 6 months) starting with the Week 78 visit (ie, 26 weeks after the Week 52 visit at the end of Year 1 of the Long-Term Follow-up period).

**Table 9.1.5: Schedule of Events – Therapeutic Corticosteroids for LFT Elevations or Decreased FVIII Activity**

|   | Steroid Treatment Period <sup>b</sup> |        |        |        |        |        |        |                     | Post-Steroid Period <sup>c</sup> |        |        |        |         |
|---|---------------------------------------|--------|--------|--------|--------|--------|--------|---------------------|----------------------------------|--------|--------|--------|---------|
|   | Week 1                                | Week 2 | Week 3 | Week 4 | Week 5 | Week 6 | Week 7 | Week 8 <sup>b</sup> | Week 1                           | Week 2 | Week 3 | Week 4 | Week 13 |
| Therapeutic corticosteroids (dose in mg/day) <sup>a</sup> | 60 mg                                 | 60 mg  | 40 mg  | 40 mg  | 40 mg  | 30 mg  | 20 mg  | 10 mg               |                                  |        |        |        |         |
| FVIII activity testing                                    |                                       |        |        |        |        |        |        |                     | X                                | X      | X      | X      |         |
| Liver function testing                                    |                                       |        |        |        |        |        |        |                     | X                                | X      | X      | X      |         |
| Hepatitis B testing <sup>d</sup>                          |                                       |        |        |        |        | X      |        |                     | X                                |        |        |        | X       |
| HCV Viral Load <sup>d</sup>                               |                                       |        |        |        |        | X      |        |                     | X                                |        |        |        | X       |

<sup>a</sup> Therapeutic oral corticosteroids may be initiated according to the parameters set out in Section 9.4.8.2.

<sup>b</sup> Following initiation or completion of steroid regimen, if a recurrence of ALT values > 1.5x ULN is reported, steroid management decisions will be based on discussions between the Investigator and Medical Monitor. Modification of the steroid regimen may take into consideration possible confounders for the ALT elevation, relationship between increases in ALT and FVIII activity, ALT/FVIII levels post steroid initiation, and adverse events related to steroid dosing. Guidance for tapering oral corticosteroid dosing can be found in Section 9.4.8.2.

<sup>c</sup> After discontinuation of oral corticosteroids, weekly labs for ALT and FVIII levels will be measured once a week for 4 weeks to ensure stability in values. If these assessments are already being done as part of normal study follow-up, they do not need to be duplicated.

<sup>d</sup> Should only be performed in subjects with a history of hepatitis B or hepatitis C.



## 9.2 Discussion of Study Design, Including Choice of Control Group

Study 270-301 is designed to be a Phase 3, single-arm, open-label study in hemophilia A patients with residual FVIII levels  $\leq 1$  IU/dL previously treated with prophylactic exogenous FVIII. Hemophilia A patients who provide written informed consent, meet the entry criteria definition of residual FVIII activity, have well-documented historical data for the previous 12 months concerning exogenous FVIII usage and bleeding episodes, and do not have antibodies to AAV5 will be eligible to enroll in the study.

Approximately 70 subjects will be enrolled at the 6E13 vg/kg BMN 270 dose. Subjects will be followed for 52 weeks post-BMN 270 infusion during which safety and efficacy assessments will be taken. After the final analysis at 52 weeks post-infusion, safety and efficacy will then continue to be assessed long-term for approximately a total of 5 years. During enrollment, the DMC will review available safety and efficacy data on an ongoing basis and may decide to recommend dosing subjects at a different dose level (not to exceed 6E13 vg/kg) based on emerging data from 270-301 and their overall benefit:risk assessment.

Study 270-301 is a self-controlled study. Parameters for each subject will be compared to a pre-treatment assessment of safety (liver function) and efficacy (number of bleeds, use of FVIII replacement therapy).

## 9.3 Selection of Study Population

Approximately 70 adult hemophilia A patients with residual FVIII levels  $\leq 1$  IU/dL may enroll into the study.

Additional criteria for participation in the study are provided in Section 9.3.1 and Section 9.3.2.

### 9.3.1 Inclusion Criteria

Individuals eligible to participate in this study must meet all of the following inclusion criteria:

1. Males  $\geq 18$  years of age with hemophilia A and residual FVIII levels  $\leq 1$  IU/dL as evidenced by medical history, at the time of signing the informed consent.
2. Must have been on prophylactic FVIII replacement therapy for at least 12 months prior to study entry. High-quality, well-documented historical data concerning bleeding episodes and FVIII usage over the previous 12 months must be available.
3. Treated/exposed to FVIII concentrates or cryoprecipitate for a minimum of 150 exposure days (EDs).





4. Willing and able to provide written, signed informed consent after the nature of the study has been explained and prior to any study-related procedures.
5. No history of FVIII inhibitor, and results from a Bethesda assay with Nijmegen modification of less than 0.6 Bethesda Units (BU) on 2 consecutive occasions (the most recent one of which should be tested at the central laboratory) at least one week apart within the past 12 months
6. Sexually active participants must agree to use an acceptable method of effective contraception--double barrier contraception (ie, condom + diaphragm; or condom or diaphragm + spermicidal gel or foam) or their female partner either using hormonal contraceptives or having an intrauterine device--for at least 6 months post-infusion. After 6 months, subjects may stop contraception use only if they have had 3 consecutive semen samples with no detectable viral vector DNA.
7. Willing to abstain from alcohol consumption for at least the first 52 weeks following BMN 270 infusion.
8. HIV positive patients may be enrolled, only if the patient has a CD4 count  $> 200/\text{mm}^3$  and an undetectable viral load.

### 9.3.2 Exclusion Criteria

Individuals who meet any of the following exclusion criteria will not be eligible to participate in the study:

1. Detectable pre-existing antibodies to the AAV5 capsid.
2. Any evidence of active infection or any immunosuppressive disorder, except for HIV infection as described in the inclusion criterion above.
3. Significant liver dysfunction with any of the following abnormal laboratory results:
  - ALT (alanine transaminase) or AST  $>2\text{X ULN}$ ;
  - Total bilirubin  $>2\text{X ULN}$ ;
  - Alkaline phosphatase  $>2\text{X ULN}$ ; or
  - INR (international normalized ratio)  $\geq 1.4$ .

Subjects whose liver laboratory assessments fall outside of these ranges may undergo repeat testing and, if eligibility criteria are met on retest, may be enrolled after confirmation by the Medical Monitor. In addition, subjects with abnormal laboratory results related to confirmed benign liver conditions (eg, Gilbert's syndrome) are considered eligible for the study notwithstanding their abnormal laboratory results and may be enrolled after discussion with the Medical Monitor.

4. Prior liver biopsy showing significant fibrosis of 3 or 4 as rated on a scale of 0-4 on the Batts-Ludwig (Batts 1995) or METAVIR (Bedossa 1996) scoring systems, or an equivalent grade of fibrosis if an alternative scale is used.



5. Evidence of any bleeding disorder not related to hemophilia A.
6. Platelet count of  $< 100 \times 10^9/L$ .
7. Creatinine  $\geq 1.5$  mg/dL.
8. Liver cirrhosis of any etiology as assessed by liver ultrasound.
9. Chronic or active hepatitis B as evidenced by positive serology testing and confirmatory HBV DNA testing. Refer to the Centers for Disease Control (CDC) table for the interpretation of serological test results in the Laboratory Manual.
10. Active Hepatitis C as evidenced by detectable HCV RNA or currently on antiviral therapy.
11. Active malignancy, except non-melanoma skin cancer.
12. History of hepatic malignancy.
13. History of arterial or venous thromboembolic events (eg, deep vein thrombosis, non-hemorrhagic stroke, pulmonary embolism, myocardial infarction, arterial embolus), with the exception of catheter-associated thrombosis for which anti-thrombotic treatment is not currently ongoing.
14. Known inherited or acquired thrombophilia, including conditions associated with increased thromboembolic risk, such as atrial fibrillation.
15. Treatment with any investigational product within 30 days or 5 half-lives of the investigational product prior to the screening period. For subjects who have received a prior investigational product, all ongoing adverse events (AEs) experienced while receiving that investigational product must have resolved prior to screening for this study.
16. Any condition that, in the opinion of the Investigator or Sponsor would prevent the patient from fully complying with the requirements of the study (including possible corticosteroid treatment outlined in the protocol) and/or would impact or interfere with evaluation and interpretation of subject safety or efficacy result.
17. Prior treatment with any vector or gene transfer agent.
18. Major surgery planned in the 52-week period following the infusion with BMN 270.
19. Use of systemic immunosuppressive agents, not including corticosteroids, or live vaccines within 30 days before the BMN 270 infusion.
20. Concurrent enrollment in another clinical study, unless it is an observational (non-interventional) clinical study that does not interfere with the requirements of the current protocol or have the potential to impact the evaluation of efficacy and safety of BMN 270 and with prior consultation with the Medical Monitor.
21. Known allergy or hypersensitivity to BMN 270 investigational product formulation.



22. Unwilling to receive blood or blood products for treatment of an adverse event and/or a bleeding episode.

### **9.3.3 Removal of Subjects from Treatment or Assessment**

Subjects may withdraw their consent to participate in the study at any time without prejudice. The Investigator must withdraw from the study any subject who requests to be withdrawn. Such subjects will always be asked about the reason(s) for withdrawal. The Investigator will discuss with the subject appropriate procedures for withdrawal from the study. The Investigator should ask the subject's consent to perform the procedures listed under the early termination visit. Should a subject withdraw from the study, all efforts will be made to complete and report the observations as thoroughly as possible up to the date of the withdrawal.

A subject's participation in the study may be discontinued at any time at the discretion of BioMarin or of the Investigator and in accordance with his/her clinical judgment. When possible, the tests and evaluations listed for the termination visit should be carried out and every effort will be made to gather follow-up safety data if possible.

BioMarin must be notified of all subject withdrawals as soon as possible. BioMarin also reserves the right to discontinue the study at any time for either clinical or administrative reasons and to discontinue participation by an individual Investigator or site for poor enrollment or noncompliance.

Reasons for which the Investigator or BioMarin may withdraw a subject from the study include, but are not limited to, the following:

- Subject requires medication or medical procedure prohibited by the protocol
- Subject does not adhere to study requirements specified in the protocol
- Subject was erroneously enrolled into the study or does not meet entry criteria and not yet been dosed with BMN 270; subjects who do not meet entry criteria but who erroneously receive BMN 270 should remain in the study for safety monitoring
- Subject is lost to follow-up

If a subject fails to return for scheduled visits, a documented effort must be made to determine the reason. If the subject cannot be reached by telephone, a certified letter should be sent to the subject requesting contact with the Investigator. This information should be recorded in the study records.

The Investigator or designee must explain to each subject, before enrollment into the study, that for evaluation of study results, the subject's protected health information obtained during



the study may be shared with the study Sponsor, regulatory agencies, and IRB/IEC/REB. It is the Investigator's (or designee's) responsibility to obtain written permission to use protected health information per country-specific regulations, such as the Health Insurance Portability and Accountability Act (HIPAA) in the US, from each subject. If permission to use protected health information is withdrawn, it is the Investigator's responsibility to obtain a written request, to ensure that no further data will be collected from the subject and the subject will be removed from the study.

### 9.3.3.1 Study Safety Evaluation Criteria

If any of the following events occur in a subject in the study who has received BMN 270 infusion, an urgent evaluation by the DMC will be required and further enrollment into the trial will be temporarily put on hold if recommended by the DMC per Section 9.1.

1. Liver dysfunction (criteria do not apply to ALT elevations with an extra-hepatic etiology):
  - ALT >5x ULN, for more than 2 weeks
  - ALT >3x ULN **and** (total bilirubin >2x ULN **or** INR >1.5)
  - ALT >3x ULN with signs and symptoms of liver dysfunction
2. The occurrence of Grade 4 or Grade 5 adverse events assessed as related to study drug (events of liver dysfunction are defined above).
3. The occurrence of an AE of hepatic failure.
4. The detection of high-titer neutralizing antibodies (>5 BU) to hFVIII following BMN 270 infusion in two subjects.
5. The occurrence of any cancer (except non-melanoma skin cancer) at any point after BMN 270 infusion.
6. The occurrence of a thromboembolic event with FVIII activity > 150 IU/dL in one subject.

If any of the following events occurs in a subject in the study who has received BMN 270 infusion, an urgent evaluation by the DMC will be required. Further enrollment into the trial will continue while DMC evaluation is ongoing, unless deemed otherwise by the DMC:

1. The detection of high-titer neutralizing antibodies (>5 BU) to hFVIII following BMN 270 infusion in one subject.
2. Occurrence of a thromboembolic event in one subject.



### **9.3.4 Subject Identification and Replacement of Subjects**

Each subject will be assigned a unique subject identifier. This unique identifier will be on all eCRF pages. In legal jurisdictions where use of initials is not permitted, a substitute identifier will be used.

Subjects who withdraw from the study after receiving BMN 270 will not be replaced.

### **9.3.5 Duration of Subject Participation**

The duration of participation for each subject will be approximately 264 weeks. This includes 4 weeks of screening, 1 day of BMN 270 infusion, 52 weeks of Post-Infusion Follow-Up, and 208 weeks of Long-Term Follow-Up.

## **9.4 Treatments**

### **9.4.1 Treatments Administered**

BioMarin and/or its designee will provide the study site with a supply of IP sufficient for the completion of the study. BioMarin is responsible for shipping study drug to clinical sites.

### **9.4.2 Identity of Investigational Product**

#### **9.4.2.1 Product Characteristics and Labeling**

BMN 270 is a sterile, clear, colorless-to-pale yellow solution for IV infusion and is supplied in a 10 mL Crystal Zenith® (CZ) vial. Each vial contains 8.5 mL of AAV5-hFVIII-SQ at a concentration of 2E13 vector genomes per mL in a pH 7.4 phosphate buffer.

Labelling follows country specific requirements.

#### **9.4.3 Storage**

At the study site, all IP must be stored under the conditions specified in the Pharmacy Manual in a secure area accessible only to the designated pharmacists and clinical site personnel. All IP must be stored and inventoried and the inventories must be carefully and accurately documented according to applicable state, federal and local regulations, ICH GCP, and study procedures.

#### **9.4.4 Directions for Administration**

After a physical examination performed by the Investigator or designee, subjects will be admitted on the day of BMN 270 infusion. If the subject is found to have an active acute illness at the time of planned infusion, then the infusion should be deferred until the illness has resolved; screening procedures may require repetition if outside the specified window. An IV catheter will be inserted into a suitable peripheral vein (eg, the median cubital vein)



and flushed with saline. FVIII replacement therapy will not be given since venipuncture is a minimally invasive procedure in these individuals under ordinary conditions.

BMN 270 will be prepared and infused as a pure solution over a dose-dependent time. Prepared drug will be kept at room temperature prior to administration. An electric syringe pump will be used to infuse through an in-line, low protein binding 0.22 micron filter. BMN 270 will be infused through the catheter using an appropriate infusion pump at a constant rate of 4 mL/min while monitoring the vital signs (pulse, blood pressure, respiration rate and temperature) at 15 minute ( $\pm 5$  minutes) intervals. The anticipated maximum interval from initiation of thawing of BMN 270 to completion of the infusion is 4 hours, although the IP has been shown to be stable at room temperature for 6 hours.

Following completion of the infusion, vital signs will be monitored hourly ( $\pm 5$  minutes). If the vital signs are stable the catheter will be removed 8 hours after the infusion. Hemostasis at the puncture site will be established by applying pressure according to standard protocol for infusing FVIII concentrates. Subjects will remain in the clinic for at least 8 hours to observe for any immediate toxicity of the procedure; in-patient observation can be extended beyond 8 hours if needed per Investigator discretion, or the subject may transfer to a separate facility based on the evaluation and judgment of the Principal Investigator after consultation with the Medical Monitor.

#### **9.4.5 Method of Assigning Subjects to Treatment Groups**

Subjects who meet all eligibility criteria (refer to Section 9.3.1 and Section 9.3.2) may be enrolled into the study. Approval by the Medical Monitor will be required prior to enrollment of each study subject. Upon their enrollment into the study, subjects will be assigned a unique subject number by the Sponsor.

Approximately 70 subjects will be enrolled at 6E13 vg/kg.

#### **9.4.6 Selection of Dose Used in the Study**

Data from an ongoing first in human study (Clinical Study 270-201) indicates that following single escalated doses of BMN 270 (6E12, 2E13, 4E13, 6E13 vg/kg), dose-related increases in FVIII activity were observed, with concurrent improvements in bleeding episodes and exogenous FVIII utilization, particularly at the 4E13 and 6E13 vg/kg dose levels. At all dose levels, BMN 270 is considered to be well-tolerated with mild increases in ALT as the most common adverse event. Please refer to the IB for detailed efficacy and safety data.

In order to further evaluate the dose-response relationship of BMN 270, subjects will be enrolled at a dose of 6E13 vg/kg. This dose is expected to be safe and effective based on



clinical experience to date in 270-201. The DMC will review emerging safety and efficacy data and may recommend that a different dose (not to exceed 6E13 vg/kg) be administered. In such a case, up to 70 additional subjects may be enrolled at the new dose.

#### **9.4.7 Blinding**

This is an open-label study.

#### **9.4.8 Prior and Concomitant Medications**

All prescription and over-the-counter medications (including dietary and herbal supplements) taken by a subject for 30 days before Screening will be recorded on the designated eCRF. The Investigator may prescribe additional medications, deemed necessary to provide adequate prophylactic or supportive care, during the study, as long as the prescribed medication is not prohibited by the protocol. In the event of an emergency, any needed medications may be prescribed without prior approval, but the Medical Monitor must be notified of the use of any contraindicated medications immediately thereafter. Any concomitant medications added or discontinued during the study should be recorded on the eCRF. Medications should, whenever possible, not be recorded in the electronic database with a frequency of PRN.

The following medications are prohibited starting 30 days before Screening and through the end of the study, and the Sponsor must be notified if a subject receives any of these during the study:

- Any investigational therapy
- Systemic immunosuppressive agents, except for corticosteroids
- Emicizumab
- Fitusiran
- Concizumab

The following medications should be avoided, starting 30 days prior to and for at least 52 weeks after BMN 270 infusion and minimized throughout the remaining duration of the study.

- Alcohol
- Herbal and natural remedies and dietary supplements
- Medications which may be hepatotoxic





Vaccines should also be avoided during this period, but in particular during the first 26 weeks unless clinically indicated.

The following medications should be avoided during oral corticosteroid therapy:

- Vaccines
- NSAIDs

#### **9.4.8.1 Concomitant Hemophilia Treatments**

Subjects on prophylactic FVIII therapy will discontinue their regular treatment regimen starting 4 weeks after the day of infusion or after FVIII activity has reached at least 5 IU/dL (whichever is earlier) and switch to an “on-demand” schedule. FVIII replacement therapy can always be taken as needed by the subject for treatment of an acute bleeding episode; the subject must carefully record his treatment and bleeding episodes in his diary. Prophylactic FVIII use can be used on a case-by-case basis and in consultation with the Medical Monitor to prevent bleeding in extenuating circumstances (eg, peri-operative).

In addition, information on FVIII usage and bleeding episodes by medical history must be well-documented and available and will be collected from subjects for the 12-month period immediately preceding study enrollment. Further information on the details that should be provided as part of the subject’s well-documented medical and FVIII usage history are provided in the On Site File Binder.

In order to enable rigorous comparisons of pre-study versus on-study FVIII usage and bleeding episodes, the Medical Monitor will review each screened patient’s prior bleed and hemophilia medication logs to determine if they are of "high-quality". Elements that will be assessed to judge the quality of such historical data may include, but are not limited to, the following:

- Date, type (eg, joint, muscle, other), location of bleeds
- Date, name, dose (calculated in IU/kg), and reason for use (eg, usual prophylaxis, one-time prophylaxis, treatment for bleed, surgery) of hemophilia medications.

#### **9.4.8.2 Therapeutic Glucocorticoid Treatment of Elevated Hepatic Transaminases**

Therapeutic oral corticosteroids (prednisone or converted equivalent) should be initiated when either of the following occurs post-BMN 270 infusion in any subject and after



consultation with the Medical Monitor (or their designee if consultation is required outside of the Medical Monitor's waking hours):

- ALT  $\geq 1.5x$  ULN in 2 consecutive assessments within 72 hours and alternative etiologies have been ruled out, or ALT  $\geq 3x$  ULN in 2 consecutive assessments within 48 hours (refer to [Table 9.7.8.3.2](#))
  - Whenever possible, a confirmatory lab draw for ALT should be performed, along with FVIII activity, prior to initiating oral corticosteroids.
  - Corticosteroids may be delayed if elevations in ALT are clearly not related to BMN 270 (eg, elevated in ALT with concurrent increase in CPK due to intensive exercise)

In addition, if FVIII activity drops  $> 50\%$  at any time post-BMN 270 infusion, a course of therapeutic oral corticosteroids should be considered upon consultation between the Investigator and the Medical Monitor.

The prescribed regimen for therapeutic oral corticosteroids is detailed in [Table 9.1.5](#).

Changes to the corticosteroid regimen should be made as follows:

**Table 9.4.8.2.1: Adjustments to Corticosteroid Regimen**

|   |   |  |
|---|---|--|
| <b>Tapering<br/>Corticosteroid<br/>Dose</b>   | Subject has been receiving oral corticosteroids $<3$ weeks  | Corticosteroids may be discontinued <b>if</b> : <ul style="list-style-type: none"> <li>• ALT <math>&lt;1.5</math> ULN; and</li> <li>• FVIII levels <math>&gt; 20</math> IU/dL and within 10% of the pre-decline FVIII levels; and</li> <li>• There is no concern for adrenal insufficiency post-withdrawal</li> </ul>            |
|   | Subject has been receiving oral corticosteroids $\geq 3$ weeks  | Corticosteroids may be tapered by 10 mg weekly <b>if</b> : <ul style="list-style-type: none"> <li>• ALT <math>&lt;1.5</math> ULN; and</li> <li>• FVIII levels <math>&gt; 20</math> IU/dL and within 10% of the pre-decline FVIII levels; and</li> <li>• There is no concern for adrenal insufficiency post-withdrawal</li> </ul> |
| <b>Increasing<br/>Corticosteroid<br/>Dose</b> | If ALT level is increasing or FVIII level is decreasing while on oral corticosteroids, any increases in oral corticosteroid dosing should be made only upon consultation with the Medical Monitor |  |

After discontinuation of oral corticosteroids, labs for ALT and FVIII levels will be measured once a week for 4 weeks to ensure stability in values.

Following initiation or completion of therapeutic oral corticosteroids, if ALT elevation  $\geq 1.5x$  ULN is reported, corticosteroid management decisions will be based on discussions between the Investigator and Medical Monitor. Modification of the corticosteroid regimen



may take into consideration possible confounders for the ALT elevation and impact on FVIII expression.

Management and monitoring of reactions to corticosteroids should be determined by the Investigator's clinical judgment in consultation with the Sponsor's Medical Monitor. This includes the contraindicated use of NSAIDs during corticosteroid treatment and specific monitoring not already covered by the schedule of events. The use of COX-2 inhibitors, while not contraindicated during corticosteroid treatment, should be limited, if possible. Practical management to prevent complications related to oral corticosteroid therapy may be undertaken at the discretion of the Investigator (eg, evaluation of glucose intolerance, hyperlipidemia etc.). Hepatitis B status and HCV viral load will be rechecked 6 weeks after the start of oral corticosteroid treatment and then 1 week and 13 weeks after the completion of oral corticosteroid treatment in subjects with a history of hepatitis B or hepatitis C. All adverse events (including any adverse events suspected to be caused by or related to corticosteroid use) should be reported as outlined in Section 10 of the protocol.

#### **9.4.8.3 Monitoring of HIV-Positive Subjects**

HIV-positive subjects may be enrolled in 270-301 if the subject has a CD4 count  $> 200/\text{mm}^3$  and an undetectable viral load.

Subjects should continue anti-retroviral therapy (ART) as prescribed and follow routine monitoring of CD4 count and viral load ([US Dept Health Human Services, 2014](#)). No alterations in the monitoring are indicated for enrolled immunocompetent HIV-positive subjects who receive corticosteroids as part of their enrollment in 270-301.

#### **9.4.9 Treatment Compliance**

Study drug will be administered to subjects at the study site and/or the dosing facility by a qualified health care professional. The quantity dispensed, returned, used, lost, etc. must be recorded on a dispensing log. Sites will be instructed to return or destroy all used and unused study drug containers.

### **9.5 Investigational Product Accountability**

The Investigator or designee is responsible for maintaining accurate records (including dates and quantities) of IP(s) received and IP lost or accidentally or deliberately destroyed. The Investigator or designee must retain all unused or expired study supplies until the study monitor (on-site CRA) has confirmed the accountability data, if allowed by local SOPs.



### **9.5.1 Return and Disposition of Clinical Supplies**

Unused study drug must be kept in a secure location for accountability and reconciliation by the study monitor. The Investigator or designee must provide an explanation for any destroyed or missing study drug or study materials (or must be referenced in their institution SOPs).

Unused study drug may be destroyed on site, per the site's standard operating procedures, but only after BioMarin has granted approval for drug destruction. The monitor must account for all study drug in a formal reconciliation process prior to study drug destruction. All study drug destroyed on site must be documented. Documentation must be provided to BioMarin or designee and retained in the Investigator study files. If a site is unable to destroy study drug appropriately, the site can return unused study drug to BioMarin upon request. The return of study drug or study drug materials must be accounted for on a study drug return form provided by BioMarin.

All study drug and related materials should be stored, inventoried, reconciled, and destroyed or returned according to applicable state and federal regulations and study procedures. For additional information, please refer to the Pharmacy Manual.

## **9.6 Dietary or Other Protocol Restrictions**

There are no dietary or other protocol restrictions for this study. Alcohol should be avoided for the first 52 weeks of the study, and particularly within 48 hours prior to lab work.

Subjects should be advised to abstain from any blood or sperm donation after BMN 270 infusion, until there is no further evidence of vector shedding.

## **9.7 Safety and Efficacy Variables**

### **9.7.1 Safety and Efficacy Measurements Assessed**

The Schedule of Events ([Table 9.1.1](#) through [Table 9.1.4](#)) describes the timing of required evaluations.

### **9.7.2 Primary Efficacy Variables**

#### **9.7.2.1 FVIII Activity**

The primary efficacy variable is change of the hFVIII activity, as measured by one-stage clotting assay, during Weeks 49-52 post-BMN 270 infusion from baseline. Each subject's hFVIII activity during Weeks 49-52 is defined as the median of the values obtained during this 4-week window. Values for FVIII activity will be excluded if obtained within 72 hours since the last infusion of exogenous FVIII protein concentrates.



If a subject has used FVIII within 72 hours of a measurement day, all efforts should be made to obtain FVIII activity measurements when a 72-hour interval without FVIII use is achieved; The 72-hour wash-out period is only intended for subjects who have achieved  $FVIII \geq 5$  IU/dL at 16 weeks after BMN 270 infusion and who have not resumed FVIII replacement therapy.

In the event of an FVIII activity level decline during the study:

- If FVIII activity has declined at least 20% from the peak but less than 35% and has declined for at least 2 consecutive assessments, FVIII activity and LFTs should be repeated every 7 days until FVIII activity is stable or increasing
- If FVIII activity has declined  $>35\%$  from the peak and has declined for at least 2 consecutive assessments, FVIII activity and LFTs should be repeated every 72 hours until FVIII activity is stable or increasing

In subjects who show an initial response to BMN 270 but who later have FVIII activity decline to  $< 5$  IU/dL, the investigator and medical monitor will review the subject's FVIII activity levels and discuss whether to resume prior FVIII prophylaxis. In addition, the investigator will notify the subject of his FVIII activity levels and will discuss with the subject the risk of bleeding and when (and if) prior FVIII prophylaxis will be resumed.

Note that fluctuations in FVIII activity are common, and if no clear trend indicating a decline in FVIII activity is observed, then this additional testing may be deferred (upon consultation between the Investigator and the Medical Monitor) until either a more clear trend of decline has been demonstrated or until the FVIII activity levels stabilize or increase.

Details on collecting FVIII activity samples are included in the Laboratory Manual.

### **9.7.3 Secondary Efficacy Variables**

#### **9.7.3.1 Factor VIII Replacement Therapy/Bleeding Episodes**

Secondary efficacy variables are:

- Change of the annualized utilization (IU/kg) of exogenous FVIII replacement therapy during Week 5 to Week 52 post BMN 270 infusion from the baseline utilization of exogenous FVIII replacement therapy calculated using subjects' historical medical records during the year prior to the enrollment.
- Change in the annualized number of bleeding episodes requiring exogenous FVIII replacement treatment during Week 5 to Week 52 of the study post BMN 270



infusion from the baseline ABR calculated using subjects' historical medical records during the year prior to the enrollment.

Subjects must have high quality documented historical data available concerning previous bleeding episodes and exogenous FVIII usage over the previous 12 months in order to be eligible to enroll in the study. During the study, subjects will be asked at each study visit to report the use of factor replacement therapy and the number of bleeding episodes since the previous visit. This information will be captured on the subject's diary or other subject records.

Subjects are strongly encouraged to immediately consult Investigator for guidance regarding exogenous FVIII administration for suspected bleeds or bleeding episodes within the first 30 days post BMN 270 infusion.

#### **9.7.4 Tertiary Efficacy Variables**

##### **9.7.4.1 Patient-Reported Outcomes (PRO)**

The Haemo-QoL-A questionnaire is a validated hemophilia-specific health-related quality of life questionnaire for adults ([Rentz, 2008, Haemophilia](#)). It consists of 41 questions covering six domains (Physical Functioning, Role Functioning, Worry, Consequences of Bleeding, Emotional Impact and Treatment Concerns). Items are answered on a 6-point Likert-type scale, ranging from 0 (None of the time) to 5 (All of the time). Higher scores mean better health-related quality of life or less impairment for a particular subscale ([Haemo-QoL Study Group, 2017](#)). Details regarding the Haemo-QoL-A assessment will be included in the On Site File Binder.

The EQ-5D-5L instrument is a self-reported questionnaire designed to measure general health status ([The EuroQol Group, 1990, Health Policy](#)) ([Brooks, 1996, Health Policy](#)). The EQ-5D-5L is composed of 2-parts: a descriptive system that assesses 5 levels of perceived problems (mobility, self-care, usual activities, pain/discomfort, and anxiety/depression) in 5 dimensions and the EQ visual analogue scale (EQ VAS) assessment for overall health. A sample copy of the EQ-5D-5L and additional information are provided in the On Site File Binder.

The Haemophilia Activities List (HAL) measures the impact of hemophilia on self-perceived functional abilities in adults ([van Genderen, 2006](#)). The instrument consists of multiple domains including lying/sitting/kneeling/standing, leg and arm function, use of transportation, self-care, household tasks, and leisure activities where subjects are asked to rate their level of difficulty with activities of daily living on a 6-point Likert-type scale from 1 (Impossible) to 6 (Never). For some items, subjects are given the choice to answer 'Not



applicable'. A sample copy of the HAL and additional information are provided in the On Site File Binder.

The Work Productivity and Activity Impairment plus Classroom Impairment Questions: Hemophilia Specific (WPAI+CIQ:HS) instrument is designed to measure the effect of disease symptom severity on work productivity and classroom productivity (if applicable) (Recht, 2014). The WPAI+CIQ:HS questionnaire yields scores related to work/classroom absenteeism, reduced on-the-job effectiveness, overall work/classroom impairment, and activity impairment. WPAI+CIQ:HS outcomes are expressed as impairment percentages, with higher numbers indicating greater impairment and less productivity (Reilly, 2002). A sample copy of the WPAI+CIQ:HS and additional information are provided in the On Site File Binder.

The Patient Reported Outcomes, Burdens, and Experiences (PROBE) questionnaire is designed to investigate and directly probe patient perspectives on outcomes they deem relevant to their life and care. PROBE aims to develop a new global tool to enhance the direct patient-voice in health care decision-making (Chai-Adisaksopha 2017). A sample copy of the PROBE questionnaire and additional information are provided in the On Site File Binder.

### **9.7.5 Immunogenicity**

Immunogenicity assays will be performed on plasma and PBMCs. The assays will include detection of anti-AAV5 capsid and anti-FVIII total antibodies, as well as determination of neutralizing antibodies against FVIII (FVIII inhibitors) and against the AAV5 capsid (Transduction Inhibitors, TI). FVIII Inhibitors will be assessed using the Bethesda assay with Nijmegen modification. Any abnormality of the liver parameters will lead to a retrospective immunogenicity assessment to evaluate FVIII- and capsid-specific cellular immunogenicity. FVIII- and capsid-specific cellular immunity will be assessed by stimulated cytokine secretion using an ELISpot assay performed on collected PBMCs.

### **9.7.6 Pharmacodynamics**

The FVIII protein concentration and activity level as measured by a validated immunoassay and by a validated FVIII activity assay, respectively, will be used for plasma profiles; FVIII protein and activity will be used to determine PD parameters.

### **9.7.7 Exploratory Assessments**

Blood samples will be collected from subjects at the time points indicated in [Table 9.1.1](#), [Table 9.1.2](#), [Table 9.1.3](#), and [Table 9.1.4](#) to evaluate biochemical, molecular, cellular, and



genetic/genomic aspects relevant to hemophilia A, coagulation, and/or AAV gene transfer, and to develop assays used for these evaluations. Subjects may choose to opt out of the exploratory genetic/genomic research being done to study or try to discover genes that are not yet known to be associated with hemophilia A.

All biomarker samples collected in this study may be used for exploratory biomarker research, including evaluation of additional biomarkers not specifically listed in the protocol. In addition, samples collected for other purposes in this study may be used for exploratory research once testing for the primary purpose has been completed.

### **9.7.8 Safety Variables**

Safety in this study will be determined from evaluation of AEs, clinical laboratory assessments with a particular attention to the liver function, vital signs assessments, physical examinations, and immunogenicity.

#### **9.7.8.1 Adverse Events**

The determination, evaluation and reporting of AEs will be performed as outlined in Section 10.

#### **9.7.8.2 Clinical Laboratory Assessments**

The scheduled clinical laboratory tests are listed in [Table 9.7.8.2.1](#). Refer to the On Site File Binder for instructions on obtaining and shipping samples.

Any abnormal test results determined to be clinically significant by the Investigator should be repeated (at the Investigator's discretion) until: (1) the cause of the abnormality is determined; (2) the value returns to baseline or to within normal limits; or (3) the Investigator determines that the abnormal value is no longer clinically significant.

All abnormal clinical laboratory results should be initialed and dated by an Investigator, along with a comment regarding whether or not the result is clinically significant. Each clinically significant laboratory result should be recorded as an adverse event.

The diagnosis, if known, associated with abnormalities in clinical laboratory tests that are considered clinically significant by the Investigator will be recorded on the AE eCRF.



**Table 9.7.8.2.1: Clinical Laboratory Tests**

| <b>Blood Chemistry</b> | <b>Hematology</b>         | <b>Urine Tests</b> | <b>Coagulation Screen including:</b> |
|------------------------|---------------------------|--------------------|--------------------------------------|
| Albumin                | Hemoglobin                | Appearance         | APTT                                 |
| BUN                    | Hematocrit                | Color              | PT/INR                               |
| Calcium                | WBC count                 | pH                 | TT                                   |
| Chloride               | RBC count                 | Specific gravity   |                                      |
| Total cholesterol      | Platelet count            | Ketones            |                                      |
| CPK                    | Differential cell count   | Protein            |                                      |
| Creatinine             | RBC indices (MCV and MCH) | Glucose            |                                      |
| CRP                    |                           | Bilirubin          |                                      |
| Glucose                |                           | Nitrite            |                                      |
| Phosphorus             |                           | Urobilinogen       |                                      |
| Potassium              |                           | Hemoglobin         |                                      |
| Total protein          |                           |                    |                                      |
| Sodium                 |                           |                    |                                      |
| Uric Acid              |                           |                    |                                      |

BUN, blood urea nitrogen; CPK, creatinine phosphokinase; CRP, C-reactive protein; PT, prothrombin time; APTT, activated partial thromboplastin time; RBC, red blood cell; WBC, white blood cell; TT, thrombin time; INR, international normalized ratio; MCV, mean corpuscular volume; MCH, mean corpuscular hemoglobin.

In addition to scheduled clinical laboratory assessments, a fasting blood lipid panel (including triglycerides, total cholesterol, HDL cholesterol, and LDL cholesterol) will be assessed at the BMN 270 infusion visit.

### **9.7.8.3 Liver Function and Hepatitis Testing**

Subjects will be screened for evidence of previous or active hepatitis B or hepatitis C infection at Screening. Subjects with documented results showing an absence of active hepatitis B or hepatitis C infection (as measured by positive surface antigen for hepatitis B or positive RNA testing for hepatitis C) 30 days prior to providing signed informed consent do not need to repeat those tests during the screening period.

Evidence of ongoing hepatitis B or hepatitis C infection is exclusionary. Subjects with evidence of prior exposure will be tested for hepatitis B and hepatitis C reactivation at Week 16.

Subjects with a previous history of hepatitis B or hepatitis C who receive therapeutic oral corticosteroids prior to Week 16 do not need to complete the Week 16 reactivation



assessment; instead, they will be tested for hepatitis B and hepatitis C reactivation at the time points listed in [Table 9.1.5](#).

A liver ultrasound and liver function testing at Screening will identify any significant hepatic dysfunction.

Liver function tests will be monitored on a regular basis; at each time point, the following LFTs should be assessed:

**Table 9.7.8.3.1: Liver Function Tests**

| Liver Function Tests |                  |                 |     |
|----------------------|------------------|-----------------|-----|
| Alkaline Phosphatase | AST (SGOT)       | Total Bilirubin | LDH |
| ALT (SGPT)           | Direct Bilirubin | GGT             |     |

ALT, alanine aminotransferase; AST, aspartate aminotransferase; GGT, gamma-glutamyltransferase; LDH, lactate dehydrogenase; SGOT, serum glutamic-oxaloacetic transaminase; SGPT, serum glutamic-pyruvic transaminase

Elevated ALT levels (above the upper limit of normal range) should be evaluated according to the following plan:

**Table 9.7.8.3.2: Evaluation of ALT Elevations**

| ALT Level               | Work-Up   |
|-------------------------|---|
| Above ULN and <1.5x ULN | <ul style="list-style-type: none"> <li>• Continue to monitor LFTs and FVIII per protocol (repeat within 7 days if next protocol scheduled visit is &gt;7 days from the time of the reported ALT elevation)</li> <li>• Consider evaluation to rule out alternative etiology (eg, concomitant medications, viral or autoimmune hepatitis, alcohol use, recreational drug use, special diets, strenuous exercise, prior and/or concurrent illnesses, exposure to environmental and/or industrial chemicals, etc.) (refer to <a href="#">Table 9.7.8.3.3</a>)</li> </ul>  |
| 1.5 - <3x ULN           | <ul style="list-style-type: none"> <li>• Repeat LFTs and FVIII within 72 hours</li> <li>• Continue to monitor LFTs weekly until ALT is stable or improving</li> <li>• Evaluate and rule out alternative etiologies (as above)</li> <li>• Consult with Medical Monitor</li> <li>• If ALT is <math>\geq 1.5x</math> ULN in 2 consecutive assessments within 72 hours and alternative etiologies have been ruled out, start oral corticosteroids (refer to <a href="#">Section 9.4.8.2</a>)</li> </ul>   |
| $\geq 3x$ ULN           | <ul style="list-style-type: none"> <li>• Consult with Medical Monitor</li> <li>• Evaluate and rule out alternative etiologies (as above)</li> <li>• Repeat LFTs and FVIII within 48 hours, and continue with monitoring of LFTs at least twice weekly for as long as the subject's ALT remains <math>\geq 3x</math> ULN</li> <li>• If <math>\geq 3x</math> ULN in 2 consecutive assessments within 48 hours, start oral corticosteroids (refer to <a href="#">Section 9.4.8.2</a>)</li> <li>• Obtain other possibly relevant laboratory evaluations (albumin, PT/INR, CRP, etc.)</li> <li>• Obtain complete blood count with differential to assess for eosinophilia</li> <li>• Obtain PBMC to evaluate potential immune response (prior to starting oral corticosteroids)</li> <li>• If no improvement in 14 days, consider gastroenterology and/or hepatology consult, abdominal workup, imaging (including MRI or ultrasound), and/or liver biopsy as appropriate</li> </ul> |

When ruling out alternative viral or autoimmune hepatitis as part of the elevated ALT workup, the following tests should be performed:

**Table 9.7.8.3.3: Viral and Autoimmune Hepatitis Testing**

| <b>Viral Hepatitis Workup Testing</b> | <b>Autoimmune Hepatitis Workup Testing</b> |
|---------------------------------------|--|
| Hepatitis A                           | Smooth muscle antibody                     |
| Hepatitis B                           | Mitochondrial antibody                     |
| Hepatitis C                           | Liver/kidney microsomal antibodies         |
| Cytomegalovirus (CMV)                 | Antinuclear antibody (ANA) HEP-2           |
| Epstein-Barr virus (EBV)              |  |
| Herpes simplex virus (HSV) 1 & 2      |  |

**9.7.8.4 HIV Testing**

HIV testing will be performed at Screening. Subjects with documented negative results within the last 30 days prior to screening do not need to be retested.

**9.7.8.5 Vital Signs, Physical Examinations and Other Observations Related to Safety**

Vital signs will include seated systolic and diastolic blood pressure, heart rate, respiration rate, and temperature. Any clinically significant change in vital signs will be recorded as an AE.

Systolic blood pressure, diastolic blood pressure, heart rate, respiration rate, and temperature will be assessed at Screening, Baseline, and at the beginning of each visit during the Post-Infusion Follow-Up and Long-Term Follow-Up periods. On the day of the BMN 270 Infusion, vital signs will be monitored prior to infusion, during the infusion every 15 minutes ( $\pm$  5 minutes), following the infusion hourly ( $\pm$  5 minutes) for at least 8 hours during the subject's stay in the clinic. Any abnormal vital sign assessments should be repeated, and both values should be recorded in the eCRF.

A complete physical examination is necessary during Screening/Baseline, at Week 26 and 52 and every 52 weeks thereafter; at other visits, brief physical examinations may be performed at the discretion of the Investigator based on the subject's clinical condition. Particular attention should be given to signs of bleeding, as well as assessing possible hemarthroses.

A complete physical examination will include general appearance (head, eyes, ears, nose, and throat), cardiovascular, dermatologic, lymphatic, respiratory, gastrointestinal, genitourinary, musculoskeletal, and neurologic systems.

A brief physical examination will include general appearance, cardiovascular, dermatologic, respiratory, gastrointestinal, musculoskeletal, and neurologic assessments.



Height will be recorded at Screening only. Weight will be recorded at Screening and then every 4 weeks thereafter through Week 52, and every 6 months during Years 2-5.

#### **9.7.8.6 Vector Shedding**

During the Post-Infusion Follow-Up period, subjects will undergo testing of various bodily samples to look for evidence of vector shedding for possible viral transmission. Bodily fluids will be tested by polymerase chain reaction (PCR). Fluids tested will include:

- Blood
- Saliva
- Semen
- Urine
- Stool

Vector shedding will also be extensively studied in the present clinical trial, at the time points indicated in [Table 9.1.1](#), [Table 9.1.2](#), [Table 9.1.3](#), and [Table 9.1.4](#). Testing will continue until at least 3 consecutive negative results are obtained. Testing of semen will continue at least through Week 12, even if 3 consecutive negative results have been recorded in that compartment prior to that time point. Subjects who have not had 3 consecutive negative semen samples by Week 52 should continue to have PCR testing in semen every 4 weeks until 3 consecutive negative samples are documented (or upon consultation between the Investigator and Medical Monitor).

Samples may be fractionated prior to shedding analysis in order to better characterize the presence, structure, and location of vector DNA and/or vector capsid within each matrix. If needed, the fractionation may be performed with samples collected specifically for shedding analysis (saliva, blood, semen, urine, feces). Alternatively, the vector DNA characterization during shedding analysis may utilize already fractionated exploratory samples obtained from the above biofluids, such as exploratory plasma samples, exploratory PBMC samples, and red blood cells recovered during PBMC/plasma isolations.

Fractionation of semen to collect purified sperm separately from non-sperm cells may be performed in parallel at any visit where semen samples are collected. The shedding analysis of a fractionated semen sample will only be performed if vector DNA was detected in the whole semen sample for the same visit. Fractionation of semen during shedding analysis may be stopped if purified sperm tested positive for vector DNA on at least three visits, or if purified sperm tested negative for vector DNA on at least three consecutive visits.



---

Contraception use may need to be extended beyond 26 weeks in individual subjects based on observed vector shedding in semen. After 26 weeks, subjects may stop contraception use only if they have had 3 consecutive negative semen samples.

Details for sample collection and storage are provided in the Laboratory Manual.



## 10 REPORTING ADVERSE EVENTS

### 10.1 Safety Parameters and Definitions

Safety assessments will consist of monitoring and recording protocol-defined AEs and SAEs; measurement of protocol-specified hematology, clinical chemistry, and urinalysis variables; measurement of protocol-specified vital signs; and other protocol-defined events of special interest that are deemed critical to the safety evaluation of the study drug.

#### 10.1.1 Adverse Events

For this protocol, an adverse event (AE) is any untoward medical occurrence in a subject, temporally associated with the use of study intervention, whether or not considered related to the study intervention.

An AE can therefore be any unfavorable and unintended sign (including an abnormal laboratory finding), symptom, or disease (new or exacerbated) temporally associated with the use of study intervention.

Events meeting the AE definition include:

- Exacerbation of a chronic or intermittent pre-existing condition including either an increase in frequency and/or intensity of the condition.
- New conditions detected or diagnosed after study intervention administration even though it may have been present before the start of the study.
- Signs, symptoms, or the clinical sequelae of a suspected drug-drug interaction.

Events not meeting the AE definition include:

- Any clinically significant abnormal laboratory findings or other abnormal safety assessments which are associated with the underlying disease, unless judged by the investigator to be more severe than expected for the subject's condition.
- The disease/disorder being studied or expected progression, signs, or symptoms of the disease/disorder being studied, unless more severe than expected for the subject's condition.
- Medical or surgical procedure (eg, endoscopy, appendectomy): the condition that leads to the procedure is the AE.
- Situations in which an untoward medical occurrence did not occur (social and/or convenience admission to a hospital).
- Anticipated day-to-day fluctuations of pre-existing disease(s) or condition(s) present or detected at the start of the study that do not worsen.



### 10.1.1.1 Bleeding and Suspected Bleeding Events

All bleeding events and suspected bleeding events, regardless of the need for exogenous FVIII therapy as treatment, should be captured in subject diaries and recorded on the designated bleeding eCRF. Bleeding events and suspected bleeding events should not be reported as adverse events, with the following exception:

- All bleeding events and suspected bleeding events which meet one or more of the criteria for being serious (refer to Section 10.2) should be reported as serious adverse events (whether or not they are bleeding events that are normal sequelae of hemophilia, and whether or not they required exogenous FVIII as treatment).

### 10.2 Serious Adverse Events

A serious adverse event (SAE) is any untoward medical occurrence that, at any dose:

- Results in death
- Is life-threatening

*Note: Life-threatening refers to an event in which the subject was at risk of death at the time of the event. It does not refer to an event, which hypothetically might have caused death, if it were more severe.*

- Requires inpatient hospitalization or prolongation of existing hospitalization

Note: In general, hospitalization signifies that the subject has been detained (usually involving at least an overnight stay) at the hospital or emergency ward for observation and/or treatment that would not have been appropriate in the physician's office or outpatient setting. Complications that occur during hospitalization are AEs. If a complication prolongs hospitalization, the event is serious.

Hospitalization for elective treatment of a pre-existing condition that did not worsen from baseline is not considered an AE.

- Results in persistent or significant disability or incapacity
- Is a congenital anomaly or birth defect in the child or fetus of a subject exposed to IP prior to conception or during pregnancy
- Is an important medical event or reaction – that, based on medical judgment, may jeopardize the subject or require medical/surgical intervention to prevent one of the other outcomes listed above (eg, anaphylaxis)

#### 10.2.1 Events of Special Interest (EOSI)

The following EOSI need to be reported to the Sponsor within 24 hours of site awareness, irrespective of seriousness, severity or causality:



- Elevation of ALT > 1.5x ULN, regardless of whether that elevation triggers an initiation or modification of oral corticosteroid treatment
- Thromboembolic event

### **10.3 Methods and Timing for Capturing and Assessing Safety Parameters**

#### **10.3.1 Adverse Event Reporting Period**

The study AE reporting period is as follows:

- After informed consent but prior to initiation of study drug, only SAEs associated with any protocol-imposed interventions will be collected. AEs occurring during this time period should be recorded on the Medical History eCRF.
- After informed consent is obtained and following infusion of study drug, the reporting period for all non-serious AEs and SAEs begins and continues for approximately 5 years or until study discontinuation/termination, whichever is longer.

The criteria for determining, and the reporting of SAEs is provided in Section 10.2.

#### **10.3.2 Eliciting Adverse Events**

Care will be taken not to introduce bias when detecting AEs and/or SAEs. Open-ended and non-leading verbal questioning of the subject is the preferred method to inquire about AE occurrences. The Investigator will record all relevant AE/SAE/EOSI information in the subject's medical record and AE Case Report Form (eCRF).

#### **10.3.3 Assessment of Seriousness, Severity, and Causality**

The Investigator responsible for the care of the subject or medically qualified designee will assess AEs for severity, relationship to study drug, and seriousness (refer to Section 10.2 for SAE definitions). These assessments must be made by a study clinician with the training and authority to make a diagnosis (eg, MD/DO, physician's assistant, nurse practitioner, or DDS).

##### **10.3.3.1 Seriousness**

The Investigator will assess if an AE should be classified as "serious" based on the seriousness criteria enumerated in Section 10.2. Seriousness serves as a guide for defining regulatory reporting obligations.

##### **10.3.3.2 Severity**

Severity (as in mild, moderate, or severe headache) is not equivalent to seriousness, which is based on subject/event outcome or action criteria usually associated with events that pose a threat to a subject's life or functioning. The Investigator will determine the severity of each





AE, SAE and EOSI using the NCI CTCAE v4.03. Adverse events that do not have a corresponding CTCAE term will be assessed according to the general guidelines for grading used in the CTCAE v4.03 as stated in [Table 10.3.3.2.1](#).

**Table 10.3.3.2.1: Adverse Event Grading (Severity) Scale**

| Grade | Description  |   |
|-------|--|---|
| 1     | Mild: asymptomatic or mild symptoms; clinical or diagnostic observations only; intervention not indicated  |   |
| 2     | Moderate: minimal, local or noninvasive intervention indicated; limiting age-appropriate instrumental activities of daily living (ADL) <sup>a</sup>                                |   |
| 3     | Severe or medically significant but not immediately life-threatening: hospitalization or prolongation of hospitalization indicated; disabling; limiting self-care ADL <sup>b</sup> |   |
| 4     | Life threatening consequences; urgent intervention indicated   | Grade 4 and 5 AEs should always be reported as SAEs |
| 5     | Death related to AE  |   |

<sup>a</sup> Instrumental ADL refer to the following examples: preparing meals, shopping for groceries or clothes, using the telephone, managing money.

<sup>b</sup> Self-care ADL refer to the following examples: bathing, dressing and undressing, feeding oneself, using the toilet, taking medications, not bedridden.

### 10.3.3.3 Causality

The Investigator will determine the relationship of an AE to the study drug and will record it on the source documents and AE eCRF. To ensure consistency of causality assessments, Investigators should apply the guidance in [Table 10.3.3.3.1](#).

**Table 10.3.3.3.1: Causality Attribution Guidance**

| <b>Relationship</b> | <b>Description</b>   |
|---------------------|--|
| Not Related         | <ul style="list-style-type: none"> <li>• Exposure to the IP has not occurred</li> </ul> <p style="text-align: center;"><b>OR</b></p> <ul style="list-style-type: none"> <li>• The administration of the IP and the occurrence of the AE are not reasonably related in time</li> </ul> <p style="text-align: center;"><b>OR</b></p> <ul style="list-style-type: none"> <li>• The AE is considered likely to be related to an etiology other than the use of the IP; that is, there are no facts, evidence, or arguments to suggest a causal relationship to the IP.</li> </ul>  |
| Related             | <ul style="list-style-type: none"> <li>• The administration of the IP and the occurrence of the AE are reasonably related in time</li> </ul> <p style="text-align: center;"><b><u>AND</u></b></p> <ul style="list-style-type: none"> <li>• The AE could possibly be explained by factors or causes other than exposure to the IP</li> </ul> <p style="text-align: center;"><b><u>OR</u></b></p> <ul style="list-style-type: none"> <li>• The administration of IP and the occurrence of the AE are reasonably related in time</li> </ul> <p style="text-align: center;"><b><u>AND</u></b></p> <ul style="list-style-type: none"> <li>• The AE is more likely explained by exposure to the IP than by other factors or causes.</li> </ul> |

Factors suggestive of a causal relationship could include (but are not limited to):

- Plausible temporal relationship
- Absence of alternative explanations
- Rarity of event in a given patient or disease state
- Absence of event prior to study drug exposure
- Consistency with study product pharmacology
- Known relationship to underlying mechanism of study drug action
- Similarity to adverse reactions seen with related drug products
- Abatement of AE with discontinuation of study drug, and/or recurrence of AE with reintroduction of study drug



The Investigator's assessment of causality for individual AE reports is part of the study documentation process. Regardless of the Investigator's assessment of causality for individual AE reports, the Sponsor will promptly evaluate all reported SAEs against cumulative product experience to identify and expeditiously communicate possible new safety findings to Investigators and applicable regulatory authorities.

## **10.4 Procedures for Recording Adverse Events**

### **10.4.1 Recording Adverse Events on a eCRF**

Investigators should use precise medical terminology when recording AEs or SAEs on the AE eCRF. Avoid colloquialisms and abbreviations.

Record only one diagnosis, sign, or symptom per event field on the AE eCRF (eg, nausea and vomiting should not be recorded in the same entry, but as 2 separate entries).

In order to classify AEs and diseases, preferred terms will be assigned by the Sponsor to the original terms entered on the AE eCRF, using MedDRA (Medical Dictionary for Regulatory Activities) terminology.

#### **10.4.1.1 Diagnosis versus Signs and Symptoms**

The Investigator will attempt to establish a diagnosis of the event based on signs, symptoms, and/or other clinical information. Whenever possible, the diagnosis (not the individual signs/symptoms) will be documented as the AE/SAE. Using accepted medical terminology, enter the diagnosis (if known). If not known, enter sign(s) and/or symptom(s). If a diagnosis subsequently becomes available, then this diagnosis should be entered on the AE (or SAE, as appropriate) eCRF, replacing the original entries where appropriate.

#### **10.4.1.2 Adverse Events Occurring Secondary to Other Events**

In general, AEs occurring secondary to other events (eg, cascade events) should be identified by their primary cause. For example, if severe diarrhea is known to have resulted in dehydration, it is sufficient to record only diarrhea as an AE or SAE on the AE eCRF. However, medically important events that may be linked and/or separated in time should be recorded as independent events on the AE eCRF. For example, if severe hemorrhage leads to renal failure, both events should be recorded separately on the AE eCRF.

#### **10.4.1.3 Persistent or Recurrent Adverse Events**

A persistent AE (duration of adverse event > 7 days) is one that extends continuously, without resolution, between subject evaluation time points. Events that change in severity



necessitate the recording of an additional AE. AEs that do not have a change in severity should be recorded only once on the eCRF.

A recurrent AE is one that occurs and resolves between subject evaluation time points, but then subsequently recurs. All recurrences of the AE should be recorded on the AE eCRF. For example, if a subject has an adverse event of ALT increased that subsequently resolves, but the subject's ALT increases again, that should be reported as two adverse events – the initial ALT increase, and the second ALT increase.

#### **10.4.1.4 Abnormal Laboratory Values**

Laboratory test results will be recorded on the laboratory results pages of the eCRF, or appear on electronically produced laboratory reports submitted directly from the central laboratory, if applicable.

Any laboratory result abnormality fulfilling the criteria for a SAE or EOSI should be reported as such, and recorded in the AE eCRF.

Any laboratory result abnormality of CTCAE Grade 4 or 5 should be recorded as an SAE in the AE eCRF.

A clinical laboratory abnormality is considered clinically significant and should be documented as an AE if not refuted by a repeat test to confirm the abnormality and **any** one or more of the following conditions is met:

- Accompanied by clinical symptoms
- Requiring a change in concomitant therapy (eg, addition of, interruption of, discontinuation of, or any other change in a concomitant medication, therapy or treatment).
- The abnormality suggests a disease and/or organ toxicity
- The abnormality is of a degree that requires active management (eg, change of dose, discontinuation of study drug, more frequent follow-up assessments, further diagnostic investigation, etc.)

**This applies to** any protocol and non-protocol specified safety and efficacy laboratory result from tests performed after the first dose of study medication that falls outside the laboratory reference range and meets the clinical significance criteria.

**This does not apply to** any abnormal laboratory result that falls outside the laboratory reference range but that does not meet the clinical significance criteria (these will be analyzed and reported as laboratory abnormalities), those that are considered AEs of the type



explicitly exempted by the protocol, or those which are a result of an AE that has already been reported.

For purposes of this study, laboratory tests showing a decreased level of FVIII activity should not be reported as adverse events unless there is an impact to clinical outcomes (eg, increased rate of bleeding, worsening of joint disease).

#### **10.4.1.5 Pre-existing Conditions**

A pre-existing condition is one that is present prior to administration of BMN 270. Such conditions should be recorded as medical history on the appropriate eCRF.

A pre-existing condition should be recorded as an AE or SAE during the study **only** if the frequency, intensity, or character of the condition worsens during the study period. It is important to convey the concept that a pre-existing condition has changed by including applicable language in the verbatim description of the event (eg, *more frequent* headaches).

#### **10.4.1.6 General Physical Examination Findings**

At screening, any clinically significant abnormality should be recorded as a pre-existing condition (refer to Section 10.4.1.5). During the study, any new clinically significant findings and/or abnormalities discovered on physical examination that meet the definition of an AE (or an SAE) must be recorded and documented as an AE or SAE on the AE eCRF.

#### **10.4.1.7 Hospitalization, Prolonged Hospitalization, or Surgery**

Any AE that results in hospitalization or prolonged hospitalization should be documented and reported as an SAE unless specifically instructed otherwise in this protocol (refer to Section 10.2).

There are some hospitalization scenarios that do not require reporting as an SAE when there is no occurrence of an AE. These scenarios include planned hospitalizations or prolonged hospitalizations to:

- Perform a protocol-mandated efficacy measurement
- Undergo a diagnostic or elective surgical procedure for a pre-existing medical condition that has not worsened
- Insert an in-dwelling IV catheter (such as a Port-a-Cath or other brand, if applicable) for administration of study drug or FVIII replacement therapy
- Receive scheduled therapy (study drug or otherwise) for the study indication



#### **10.4.1.8 Deaths**

All deaths that occur during the AE reporting period (refer to Section 10.3.1), regardless of attribution, will be recorded on the AE eCRF and expeditiously reported to the Sponsor as an SAE.

When recording a death, the event or condition that caused or contributed to the fatal outcome should be recorded as the single medical concept on the eCRF. If the cause of death is unknown and cannot be ascertained at the time of reporting, record “Unexplained Death” or “Death of Unknown Cause” on the AE eCRF.

#### **10.4.1.9 Pregnancy**

Although not an AE per se, pregnancy in the partner of a subject taking trial medication should be reported expeditiously to the Sponsor to facilitate outcome monitoring by the Sponsor. Pregnancy in partner should be reported during the period up to 5 years after viral infusion.

Pregnancy in a partner should be reported within 24 hours of the site becoming aware of the pregnancy by entering the information on the Pregnancy eCRF and submitting to BPV within 24 hours of the site becoming aware of the event. The Investigator must make every effort to follow the subject’s partner (with that partner’s consent) through resolution of the pregnancy (delivery or termination) and to report the resolution on the Pregnancy Follow-up eCRF. In the event of pregnancy in the partner of a study subject, the Investigator should make every reasonable attempt to obtain the woman’s consent for release of protected health information.

Abortion, whether therapeutic or spontaneous, should always be classified as an SAE (as the Sponsor considers these to be medically significant), recorded on the AE eCRF, and expeditiously reported to the Sponsor as an SAE.

### **10.5 Reporting Requirements**

#### **10.5.1 Expedited Reporting Requirements**

All SAEs and EOSI that occur during the course of the AE Reporting Period (refer to Section 10.3.1), whether or not considered related to study drug, must be reported by entering the information in the AE eCRF and submitting to BPV within 24 hours of the site becoming aware of the event. Investigators should not wait to collect information that fully documents the event before notifying BPV of an SAE. BioMarin may be required to report certain SAEs to regulatory authorities within 7 calendar days of being notified about the event; therefore, it is important that Investigators submit any information requested by BioMarin as soon as it becomes available. IND safety reports will be submitted within 7 calendar days for



fatal or life-threatening unexpected suspected adverse reactions (SUSARs) and within 15 calendar days for other non-life-threatening SUSARs

The Sponsor is responsible for identifying, preparing and reporting all SUSARs to the relevant competent authorities, ethics committees and Investigators in accordance with the requirements identified in the Clinical Trials Regulations.

If the EDC is unavailable, all SAEs should be reported to BPV by completing the SAE Report Form and faxing or emailing the completed form to BPV within 24 hours of the site becoming aware of the event. Once the EDC is available, the information should be entered in the AE eCRF.

### **10.5.2 Institutional Review Board or Independent Ethics Committee Reporting Requirements**

Reporting of SAEs to the Independent Ethics Committee (IEC) or Institutional Review Board (IRB) will be done in compliance with the standard operating procedures and policies of the IEC/IRB and with applicable regulatory requirements. Adequate documentation must be obtained by BioMarin showing that the IEC/IRB was properly and promptly notified as required.

### **10.6 Follow-up of Subjects after Adverse Events**

After the initial AE/SAE/EOSI report, the Investigator is required to proactively follow each subject at subsequent visits/contacts. All AEs/SAEs/EOSI will be followed until resolution, stabilization, the event is otherwise explained, or the subject is lost to follow-up. Resolution of AEs/SAEs/EOSI (with dates) should be documented on the AE eCRF and submitted to BioMarin Pharmacovigilance and in the subject's medical record to facilitate source data verification.

For some SAEs and EOSI, the Sponsor may follow up by telephone, fax, electronic mail, and/or a monitoring visit to obtain additional case details (eg, hospital discharge summary, consultant report, or autopsy report) deemed necessary to appropriately evaluate the SAE or EOSI report.

### **10.7 Post-Study Adverse Events**

At the last scheduled visit, the Investigator should instruct each subject to report, to the Investigator and/or to BPV directly, any subsequent SAEs that the subject's personal physician(s) believes might be related to prior study drug.



The Investigator should notify the study Sponsor of any death or SAE occurring at any time after a subject has discontinued or terminated study participation, if the Investigator believes that the death or SAE may have been related to prior study drug. The Sponsor should also be notified if the Investigator should become aware of the development of cancer or of a congenital anomaly in a subsequently conceived offspring of a subject that participated in this study.

### **10.8 Urgent Safety Measures**

The regulations governing clinical trials state that the Sponsor and Investigator are required to take appropriate urgent safety measures to protect subjects against any immediate hazards that may affect the safety of subjects, and that the appropriate regulatory bodies should be notified according to their respective regulations. According to the European Union (EU) Clinical Trial Directive 2001/20/EC, "...in the light of the circumstances, notably the occurrence of any new event relating to the conduct of the trial or the development of the investigational medicinal product where that new event is likely to affect the safety of the patients, the Sponsor and the Investigator shall take appropriate urgent safety measures to protect the patients against any immediate hazard. The Sponsor shall forthwith inform the competent authorities of those new events and the measures taken and shall ensure that the IRB/IEC/REB is notified at the same time."

The reporting period for these events which may require the implementation of urgent safety measures is the period from the time of signing of the ICF through the completion of the last study visit or at the Early Termination Visit (ETV). Investigators are required to report any events which may require the implementation of urgent safety measures to BioMarin within 24 hours.

Examples of situations that may require urgent safety measures include discovery of the following:

- Lack of study scientific value, or detrimental study conduct or management
- Discovery that the quality or safety of the IP does not meet established safety requirements





---

### 10.9 BioMarin Pharmacovigilance Contact Information

Contact information for BioMarin Pharmacovigilance is as follows:

BioMarin Pharmaceutical Inc.

Address 105 Digital Drive  
Novato, CA 94949  
Phone: +1 (415) 506-6179  
Fax: +1 (415) 532-3144  
E-mail: [drugsafety@bmrn.com](mailto:drugsafety@bmrn.com)

The Investigator is encouraged to discuss with the Medical Monitor any AEs for which the issue of seriousness is unclear or questioned. Contact information for the Medical Monitor is as follows:

Name: PI [REDACTED], MD, MPhil  
Address: 105 Digital Drive  
Novato, CA 94949 USA  
Phone: PI [REDACTED]  
E-mail: PI [REDACTED]



## **11 APPROPRIATENESS OF MEASUREMENTS**

The measures of efficacy to be used in this study are standard, ie, widely used and generally recognized as reliable, accurate, and relevant (able to discriminate between effective and ineffective agents). The measures of safety used in this study are routine clinical and laboratory procedures.

The chromogenic FVIII assay and the one-stage clot FVIII assay are both validated and utilize CE marked reagents. The exploratory FVIII activity assay will be used for exploratory purposes only.



---

## 12 STUDY PROCEDURES

### 12.1 Prestudy

An ICF must be signed and dated by the patient, the Investigator or designee and witness (if required) before any study-related procedures are performed.

### 12.2 Screening Visit

Screening assessments should be performed within 28 days of BMN 270 infusion (and must be performed within 42 days prior to BMN 270 infusion), while baseline assessments will take place within 7 days prior to BMN 270 infusion (Day 1). Should the screening visit occur within 30 days of the drug infusion, physical examination, vital signs, blood chemistry, LFTs, hematology, urine tests, and coagulation tests do not need to be repeated at Baseline.

The following procedures will be performed during the Screening Period:

- Demographics (age, sex, race, ethnicity)
- Full medical history, including hemophilia A history, Hepatitis B, Hepatitis C, and HIV.
- Complete Physical Examination
- Height and weight
- Vital Signs (systolic and diastolic blood pressure, heart rate, respiration rate, and temperature)
- Assessment of Adverse Events and Concomitant Medications
- Documentation of bleeding episodes and FVIII usage (by either subject or clinical information) for the previous 12 months
  - Further information on details to be included in documentation of previous bleeding episodes and FVIII usage, refer to the On Site File Binder.
- Distribution of subject diaries and training in diary completion
- Electrocardiogram
- Liver Ultrasound
- Samples for hFVIII Assays
  - Baseline FVIII activity – chromogenic FVIII assay
  - Baseline FVIII activity level – one-stage clot FVIII assay
  - hFVIII coagulation activity exploratory assay (collected but not tested prior to enrollment)

- hFVIII inhibitors (Bethesda assay with Nijmegen modification)
- hFVIII total antibody assay (collected but not tested prior to enrollment)
- hFVIII protein assay (collected but not tested prior to enrollment)
- Blood sample for AAV5 total antibody (TAb) assay
- Screen for Hepatitis B, Hepatitis C, and HIV if required (subjects with documented negative results 30 days prior to informed consent being obtained do not need to be retested)
- Blood chemistry, hematology, and coagulation tests (refer to [Table 9.7.8.2.1](#))
- Urine Tests (refer to [Table 9.7.8.2.1](#))
- Liver Function Tests (refer to [Table 9.7.8.3.1](#))
- Blood samples for Biomarker testing (including HLA genotyping and FVIII genotyping status)

### 12.2.1 “Smart Rescreening” Visit

Subjects who undergo smart rescreening must complete the rescreening assessments and receive the infusion within 90 days of signing the original consent. Subjects who do not complete dosing within 90 days will be required to re-consent and undergo all screening procedures. Subjects may not undergo smart rescreening more than once.

If a patient has to be screened again because the original assessments have fallen out of the 28 + 14 day period allowed for Screening (refer to Section [12.2](#)), then only the following assessments need to be performed (rather than the full list indicated in Section [12.2](#)) for the patient to be successfully re-screened for the study:

- Vital signs
- Assessment of Adverse Events and Concomitant Medications
- Documentation of bleeding episodes and FVIII usage (by either subject or clinical information)
- hFVIII Assays (only the hFVIII inhibitor level (Bethesda assay with Nijmegen modification))
- Blood sample for AAV5 Total Antibody assay
- Blood chemistry, hematology, and coagulation tests (refer to [Table 9.7.8.2.1](#))
- Urine Tests (refer to [Table 9.7.8.2.1](#))
- Liver Function Tests (refer to [Table 9.7.8.3.1](#))

### 12.3 Baseline Visit

Baseline values will be recorded from 1 to 7 days prior to the treatment visit. The following procedures will be performed during the Baseline Period:

- Brief physical examination
- Vital signs
- Assessment of Adverse Events and Concomitant Medications
- Documentation of bleeding episodes and FVIII usage (by either subject or clinical information)
- Blood sample for AAV5 TI assay
- Blood sample for AAV5 TAb assay
- Blood chemistry, hematology, and coagulation tests (refer to [Table 9.7.8.2.1](#))
- Urine Tests (refer to [Table 9.7.8.2.1](#))
- Liver Function Tests (refer to [Table 9.7.8.3.1](#))
- Samples for hFVIII Assays
  - Baseline FVIII activity – chromogenic FVIII assay
  - Baseline FVIII activity level – one-stage clot FVIII assay
  - hFVIII coagulation activity exploratory assay
  - hFVIII inhibitors (Bethesda assay with Nijmegen modification)
  - hFVIII total antibody assay
  - hFVIII protein assay
- PBMC collection for CTL baseline
- Von Willebrand Factor Antigen (VWF:Ag)
- Direct Thrombin test
- TGA Assay
- PCR of vector DNA in blood, saliva, urine, semen, and stools
- Exploratory biomarker assessments
- Haemo-QoL-A assessment
- EQ-5D-5L
- Hemophilia Activities List (HAL)



- Work Productivity and Activity Impairment plus Classroom Impairment Questions: Hemophilia Specific (WPAI+CIQ:HS) questionnaire
- Patient Reported Outcomes, Burdens, and Experiences (PROBE) questionnaire

#### **12.4 Treatment Visit/BMN 270 Infusion Visit (Day 1)**

There will be one treatment visit for each subject. Subjects will remain in the clinic for at least 8 hours for the BMN 270 Infusion Visit. The following procedures will be performed during the BMN 270 Infusion Visit:

- Brief physical examination
- Assessment of Adverse Events and Concomitant Medications
- AAV5 TAb Assay (sample collected pre-infusion for analysis)
- Fasting lipid panel (blood triglycerides, total cholesterol, HDL cholesterol, and LDL cholesterol) (sample collected pre-infusion)
- BMN 270 Infusion
- Vital Signs
  - Vital signs will be recorded prior to BMN 270 infusion and then every 15 minutes ( $\pm$  5 minutes) during BMN 270 infusion. Following infusion, vital signs will be monitored every 1 hour ( $\pm$  5 minutes) for at least 8 hours during the subject's stay in the clinic.
- PCR of vector DNA in blood, saliva, urine, semen, and stools
  - Collection of samples for PCR testing should occur between 2 and 24 hours after the BMN 270 infusion has been completed

#### **12.5 BMN 270 Infusion Follow-Up Visits – Weeks 1-26**

After BMN 270 has been infused, subjects will return to the study site every week ( $\pm$  48 hours) during Weeks 1-26, when the following procedures will be completed:

##### **12.5.1 Once per week (Weeks 1 through 26)**

The following procedures will be performed at one visit per week from Weeks 1 through 20:

- Brief physical examination (complete physical examination at Week 26)
- Assessment of Adverse Events and Concomitant Medications (including review of subject diary for bleeding and FVIII use)
- Vital Signs
- Liver Function Tests (refer to [Table 9.7.8.3.1](#))

- LFTs may be monitored more or less frequently (and in particular when ALT values are  $>1.5x$  ULN) based on discussion between the Medical Monitor and the Investigator and review of subject data, but LFTs will be monitored at least twice weekly during periods when a subject's ALT is  $\geq 3x$  ULN.
- Samples for FVIII Assays
  - FVIII activity level (chromogenic FVIII assay)
  - FVIII activity level (one-stage clot FVIII assay)
  - FVIII coagulation activity exploratory assay
  - Bethesda assay (with Nijmegen modification) for hFVIII inhibitor level
  - FVIII protein assay

#### **12.5.2 Week 1 – Day 4**

On Day 4 of Week 1, the following procedures will be performed:

- PCR of vector DNA in blood, saliva, urine, semen, and stools
- Liver Function Tests (refer to [Table 9.7.8.3.1](#))

#### **12.5.3 Week 1 – Day 8**

On Day 8, the following procedures will be performed, in addition to the weekly assessments required in Section [12.5.1](#):

- PCR of vector DNA in blood, saliva, urine, semen, and stools

#### **12.5.4 Every 2 Weeks (Week 2, 4, 6, 8, 10, 12, 14, 16, 18, 20, 22, 24, and 26)**

At Weeks 2, 4, 6, 8, 10, 12, 14, 16, 18, 20, 22, 24, and 26 the following procedure will be performed:

- PBMC collection

#### **12.5.5 Weeks 2, 4, 10, 16, 22, and 26**

At Weeks 2, 4, 10, 16, 22, and 26 the following procedure will be performed:

- Blood chemistry, hematology, and coagulation tests (refer to [Table 9.7.8.2.1](#))

#### **12.5.6 Weeks 2, 3, 4, 6, 8, 12, 16, 20, 24, and 26**

At Weeks 2, 3, 4, 6, 8, 12, 16, 20, 24, and 26, the following procedure will be performed:

- PCR of vector DNA in blood, saliva, urine, semen, and stools

- Collection to occur until at least 3 consecutive negative results are obtained. Semen samples should continue to be collected and tested through Week 12, even if 3 consecutive negative results in that compartment have been recorded prior to that time point.

#### **12.5.7 Weeks 4, 12, and 26**

At Weeks 4, 12, and 26, the following procedure will be performed:

- Haemo-QoL-A assessment
- EQ-5D-5L
- HAL
- WPAI+CIQ:HS
- PROBE

#### **12.5.8 Every 4 Weeks (Weeks 4, 8, 12, 16, 20, and 24) Plus Week 26**

At Weeks 4, 8, 12, 16, 20, 24, and 26, the following procedures will be performed:

- Weight (not performed at Week 26)
- FVIII antibody titer

#### **12.5.9 Every 8 Weeks (Weeks 8, 16, and 24)**

At Weeks 8, 16, and 24, the following procedures will be performed:

- AAV5 TAb assay
- AAV5 TI assay

#### **12.5.10 Weeks 6, 13, 16, 20, 24, and 26**

At Weeks 6, 13, 16, 20, 24, and 26, the following procedures will be performed:

- Exploratory biomarker assessments

#### **12.5.11 Weeks 12 and 26**

At Weeks 12 and 26, the following procedure will be performed:

- Urine Tests (refer to [Table 9.7.8.2.1](#))

#### **12.5.12 Week 13 and 26**

At Weeks 13 and 26, the following procedures will be performed:

- Direct Thrombin test
- VWF:Ag





### 12.5.13 Week 16

At Week 16, the following procedure will be performed:

- Test for Hepatitis B and Hepatitis C reactivation (only in subjects with evidence of prior exposure to hepatitis B and/or hepatitis C)
  - Subjects who receive therapeutic oral corticosteroids prior to Week 16 do not need to complete the Week 16 reactivation assessment; instead, they will be tested for hepatitis B and hepatitis C reactivation at the time points listed in [Table 9.1.5](#).

### 12.5.14 Week 20, 24, and 26

At Week 20, 24, and 26, the following procedure will be performed:

- TGA Assay

### 12.6 Post-Infusion Follow-Up – Weeks 27-52

During Weeks 27-36, subjects will return to the study site weekly ( $\pm$  48 hours). During Weeks 37-52, subjects will return to the study site every 2 weeks (Week 38, 40, 42, 44, 46, 48, 50, and 52) ( $\pm$  1 week). At these visits, the following procedures will be completed:

#### 12.6.1 Every Visit

At every visit (Weeks 27-36, 38, 40, 42, 44, 46, 48, 50, and 52), the following procedures will be performed:

- Physical examination
  - Brief physical examination should be performed at all weeks except Week 26, when a complete physical examination should be performed
- Assessment of Adverse Events and Concomitant Medications (including review of subject diary for bleeding and FVIII use)
- Vital Signs
- Liver Function Tests (refer to [Table 9.7.8.3.1](#))
  - LFTs may be monitored more or less frequently (and in particular when ALT values are  $>1.5x$  ULN) based on discussion between the Medical Monitor and the Investigator and review of subject data, but LFTs will be monitored at least twice weekly during periods when a subject's ALT is  $\geq 3x$  ULN.
- FVIII Assays
  - FVIII activity level (chromogenic FVIII assay)
  - FVIII activity level (one-stage clot FVIII assay)

- FVIII coagulation activity exploratory assay
- Bethesda assay (with Nijmegen modification) for FVIII inhibitor level
- FVIII protein assay

**12.6.2 Weeks 28, 30, 32, 34, 36, 44, and 52**

At Weeks 28, 30, 32, 34, 36, 44, and 52, the following procedure will be performed:

- PBMC collection

**12.6.3 Every 4 Weeks (Weeks 28, 32, 36, 40, 44, 48, 52)**

At Weeks 28, 32, 36, 40, 44, 48, and 52, the following procedure will be performed:

- Weight

**12.6.4 Weeks 32, 36, 44, and 52**

At Weeks 32, 36, 44, and 52, the following procedures will be performed:

- Blood chemistry, hematology, and coagulation tests (refer to [Table 9.7.8.2.1](#))
- FVIII antibody titer

**12.6.5 Weeks 32, 36, 40, 44, 48, and 52**

At Weeks 32, 36, 40, 44, 48, and 52, the following procedures will be performed:

- Exploratory biomarker assessments
- TGA Assay
- PCR of vector DNA in blood, saliva, urine, semen, and stools
  - Sample testing to occur until at least 3 consecutive negative sample results have been obtained. Subjects who have not had 3 consecutive negative semen samples by Week 52 should continue to have PCR testing of semen every 4 weeks until 3 consecutive negative samples are documented (or upon consultation between the Investigator and Medical Monitor).

**12.6.6 Week 32, 36, and 52**

At Week 32, 36, and 52, the following procedure will be performed:

- AAV5 TAb Assay
- AAV5 TI Assay

**12.6.7 Week 38 and 52**

At Weeks 38 and 52, the following procedures will be performed:

- Urine Tests (refer to [Table 9.7.8.2.1](#))
- Direct Thrombin test
- VWF:Ag

#### **12.6.8 Week 52**

At Week 52, the following procedures will be performed:

- Haemo-QoL-A assessment
- EQ-5D-5L
- HAL
- WPAI+CIQ:HS
- PROBE

#### **12.7 Post-Infusion Follow-Up – Years 2-5**

During Years 2-5 of Post-Infusion Follow-up, the following procedures will be completed:

##### **12.7.1 Year 2 – Every 4 Weeks**

During Year 2, every 4 weeks (+ 2 weeks, or as scheduled to align with visits for performing assessments to be done every 3 months [Section [12.7.3](#)]), the following procedures will be performed:

- Liver Function Tests (refer to [Table 9.7.8.3.1](#))
  - LFTs may be monitored more or less frequently (and in particular when ALT values are  $>1.5x$  ULN) based on discussion between the Medical Monitor and the Investigator and review of subject data, but LFTs will be monitored at least twice weekly during periods when a subject's ALT is  $\geq 3x$  ULN.
- FVIII Assays
  - FVIII activity level (chromogenic FVIII assay)
  - FVIII activity level (one-stage clot FVIII assay)
  - FVIII coagulation activity exploratory assay
  - Bethesda assay (with Nijmegen modification) for FVIII inhibitor level
  - FVIII protein assay

##### **12.7.2 Years 3-5 – Every 6 Weeks**

During Years 3-5, every 6 weeks ( $\pm 2$  weeks), the following procedures will be performed:

- Liver Function Tests (refer to [Table 9.7.8.3.1](#))

- LFTs may be monitored more or less frequently (and in particular when ALT values are  $>1.5x$  ULN) based on discussion between the Medical Monitor and the Investigator and review of subject data, but LFTs will be monitored at least twice weekly during periods when a subject's ALT is  $\geq 3x$  ULN.
- FVIII Assays
  - FVIII activity level (chromogenic FVIII assay)
  - FVIII activity level (one-stage clot FVIII assay)
  - FVIII coagulation activity exploratory assay
  - Bethesda assay (with Nijmegen modification) for FVIII inhibitor level
    - If a subject tests positive in the Bethesda assay (with Nijmegen modification) during Years 3-5, a fresh sample should be collected within 4 weeks of the initial visit that had a positive result.
  - FVIII protein assay

### **12.7.3 Years 2-5 – Every 3 Months**

Every 3 months ( $\pm 2$  weeks), the following procedures will be performed:

- Physical examination
  - Complete physical examination will be performed every 52 weeks; brief physical examination may be performed at other visits.
- Assessment of Adverse Events and Concomitant Medications (including review of subject diary for bleeding and FVIII use)
- Vital Signs
- AAV5 TAb Assay
- AAV5 TI Assay
- FVIII antibody titer
- Exploratory biomarker assessments
- PBMC collection
- VWF:Ag
- Direct Thrombin test
- TGA Assay

### **12.7.4 Years 2-5 – Every 4 Weeks (As Needed)**

The following assessment should be performed every 4 weeks during Years 2-5, as needed:

- PCR of vector DNA in blood, saliva, urine, semen, and stools

Sample testing during Years 2-5 is not required if at least 3 consecutive samples are clear during the Post-Infusion Follow-Up period in Weeks 1-52. Subjects who have not had 3 consecutive negative semen samples by Week 52 should continue to have PCR testing of semen every 4 weeks until 3 consecutive negative samples are documented (or upon consultation between the Investigator and Medical Monitor).

### **12.7.5 Years 2-5 – Every 6 Months**

Every six months starting at the Week 78 visit (ie, 26 weeks after the Week 52 visit at the end of Year 1 of the Long-Term Follow-up period), the following procedures will be performed:

- Weight
- Blood chemistry, hematology, and coagulation tests (refer to [Table 9.7.8.2.1](#))
- Urine Tests (refer to [Table 9.7.8.2.1](#))
- Haemo-QoL-A assessment
- EQ-5D-5L
- HAL
- WPAI+CIQ:HS
- PROBE

### **12.8 Early Termination Visit**

The Early Termination visit will occur on the date the subject withdraws from the study, even if the date does not correspond to a protocol-specific visit.

If a subject leaves the study prior to the Week 260 visit, the subject will be asked to return to the study site and complete an Early Termination visit. At the Early Termination visit, as many of the following assessments as possible should be done:

- Physical examination
- Weight
- Assessment of Adverse Events and Concomitant Medications (including review of subject diary for bleeding and FVIII use)
- Vital Signs
- Blood chemistry, hematology, and coagulation tests (refer to [Table 9.7.8.2.1](#))

- Urine Tests (refer to [Table 9.7.8.2.1](#))
- Liver Function Tests (refer to [Table 9.7.8.3.1](#))
- FVIII Assays
  - FVIII activity level (chromogenic FVIII assay)
  - FVIII activity level (one-stage clot FVIII assay)
  - FVIII coagulation activity exploratory assay
  - Bethesda assay (with Nijmegen modification) for FVIII inhibitor level
  - FVIII protein assay
- AAV5 TAb Assay
- AAV5 TI Assay
- FVIII antibody titer
- Exploratory biomarker assessments
- PBMC collection
- VWF:Ag
- Direct Thrombin test
- TGA Assay
- PCR of vector DNA in blood, saliva, urine, semen, and stools
  - Sample testing at the ETV is not required if at least 3 consecutive samples were clear during the Post-Infusion Follow-Up period.
- Haemo-QoL-A assessment
- EQ-5D-5L
- HAL
- WPAI+CIQ:HS
- PROBE

## 12.9 End of Study

The study will end after the last subject yet to complete the last Long-Term Follow-Up visit (Week 260) does so, has transferred to another BMN 270 study, is withdrawn from the study, or discontinues from the study. BioMarin reserves the right to discontinue the study any time for clinical or administrative reasons and to discontinue participation of an individual Investigator or site for clinical or administrative reasons, including, but not limited to, poor enrollment or noncompliance with procedures of the protocol or GCP. In addition, the study



---

may be terminated if, in the opinion of BioMarin, the safety of the study subjects may be compromised.



### **13 DATA QUALITY ASSURANCE**

BioMarin personnel or designees will visit the study site prior to initiation of the study to review with the site personnel information about the IP, protocol and other regulatory document requirements, source document requirements, eCRFs, monitoring requirements, and procedures for reporting AEs, including SAEs.

At visits during and after the study, a CRA will monitor the site for compliance with regulatory documentation, with a focus on accurate and complete recording of data on eCRFs from source documents, adherence to protocol, randomization (if applicable), SAE reporting and drug accountability records.

Data quality control and analysis will be performed by BioMarin or a designee, based on a predefined analysis plan.





---

## 14 STATISTICAL METHODS AND DETERMINATION OF SAMPLE SIZE

### 14.1 Statistical and Analytical Plans

The statistical analysis plan (SAP) will provide additional details on the planned statistical analysis. Unless otherwise stated, all analyses will be performed using SAS.

#### 14.1.1 Interim Analyses

An interim analysis is planned after 20 treated subjects have completed the Week 26 visit (or have discontinued study participation prior to Week 26).

The primary efficacy endpoint for the interim analysis is change in the hFVIII activity, as measured by one-stage clotting assay, during Weeks 23-26 post-BMN 270 infusion from baseline. Each subject's hFVIII activity during Weeks 23-26 is defined as the median of the values obtained during this 4-week window. Values for hFVIII activity will be excluded if obtained within 72 hours since the last infusion of exogenous FVIII protein concentrates. A 2-sided one-sample t-test will be used to test the null hypothesis that the change is 0 or less against the alternative hypothesis that the change is greater than 0. In addition, subjects' hFVIII activity post-Week 23, defined as the median of the values obtained from Week 23 to the time of last follow-up, will be analyzed similarly as an important sensitivity analysis, utilizing additional data beyond Week 26. Descriptive summaries of the proportions of subjects whose FVIII activity during Weeks 23-26 and from Week 23 to the time of last follow-up is greater than or equal to select thresholds, such as 15, 25 and 30 IU/dL, and the confidence intervals of the proportions will be provided, respectively. The FVIII activity as measured by chromogenic assay will be analyzed similarly, as a supportive analysis.

The Hochberg procedure will be used to adjust for multiplicity of the interim analysis at Week 26 and the final analysis at Week 52 of the primary efficacy endpoint. (Regardless of the interim analysis results, the study will continue and the final analysis will be performed at Week 52.) At the final analysis at Week 52, the secondary efficacy endpoints will be tested hierarchically; the level of significance will be determined by the truncated Hochberg procedure for parallel gatekeeping. These multiple comparison procedures are described in greater detail in Section [14.2](#).

The secondary and tertiary endpoints will be summarized descriptively at the interim (Week 26) analysis.



### **14.1.2 Procedures for Accounting for Missing, Unused and Spurious Data**

Because the completeness of the data affects the integrity and accuracy of the final study analysis, every effort should be made to ensure complete, accurate, and timely data collection and, therefore, avoid missing data.

Sensitivity analyses will be conducted to assess the impact of missing data on the primary efficacy endpoint analysis. Additional details regarding the handling of missing data will be provided in the SAP.

### **14.2 Primary and Secondary Efficacy Endpoints**

For the primary efficacy endpoint at Week 52 (ie, the change in the hFVIII activity during Weeks 49-52 post-BMN 270 infusion from baseline, as measured by one-stage clotting assay), a one-sample t-test will be used to test the null hypothesis that the change is 0 or less against the alternative hypothesis that the change is greater than 0. Descriptive summaries of the proportions of subjects whose FVIII activity during Weeks 49-52 is greater than or equal to select thresholds, such as 15, 25 and 30 IU/dL, and the confidence intervals of the proportions will also be provided. The FVIII activity as measured by chromogenic assay will be analyzed similarly, as a supportive analysis.

For the first secondary efficacy endpoint at Week 52 (ie, the change in the annualized utilization (IU/kg) of exogenous FVIII replacement therapy during Weeks 5-52 post-BMN 270 infusion from baseline), a one-sample t-test will be performed to test the null hypothesis that the change is 0 or greater against the alternative hypothesis that the change is less than 0.

For the second secondary efficacy endpoint at Week 52 (ie, the change in ABR, annualized bleeding rate, during Weeks 5-52 post-BMN 270 infusion from baseline), a one-sample t-test will be performed to test for non-inferiority of BMN 270 against FVIII prophylaxis (ie, the baseline ABR calculated using subjects' historical medical records during the year prior to enrollment) using a margin of 3.5, ie, to test the null hypothesis that the change is 3.5 or greater against the alternative hypothesis that the change is less than 3.5. If non-inferiority is demonstrated, the test for superiority of BMN 270 against FVIII prophylaxis will be performed. The primary analysis of this endpoint is planned to be performed pooling all 70 enrolled subjects, assuming the baseline ABR of the first enrolled 20 subjects (whose baseline data is entirely based on historical medical records) and the baseline ABR of the later enrolled 50 subjects (whose baseline data is based on both data from historical medical records and data collected during study BMN 270-902) are similar. The poolability will be



examined by comparing the corresponding baseline ABRs. Details will be provided in the statistical analysis plan.

The primary and secondary efficacy hypotheses will be tested hierarchically according to the order described above. Multiple comparison procedures are described in greater detail in the following.

As described in Section 14.1.1, an interim analysis is planned after 20 treated subjects have completed the Week 26 visit (or have discontinued study participation prior to Week 26).

For controlling the probability of a Type I error for the interim and final analyses of the primary efficacy endpoint, the Hochberg procedure will be used. That is, if both the interim and final p-values are  $\leq 0.05$ , then both are declared statistically significant; otherwise, if either p-value is  $\leq 0.025$ , then that result is significant. (All p-values are 2-sided.) Since the final analysis results are not available at the time of the interim analysis, the procedure will be implemented as follows.

- If  $p \leq 0.025$  at the interim analysis, then the interim result is declared significant and the final analysis is carried out at the 0.05 level.
- If  $0.025 < p \leq 0.05$  at the interim analysis, then the final analysis is carried out at the 0.05 level. However, the significance of the interim result cannot be established at the time of the interim analysis; if  $p \leq 0.05$  for the final analysis, then both the interim and final analyses are declared significant, but if  $p > 0.05$  for the final analysis, then neither the interim nor the final analysis is declared significant.
- If  $p > 0.05$  at the interim analysis, then the interim analysis is not declared significant, and the final analysis is carried out at the 0.025 level.

Regardless of the interim analysis results, the study will continue to completion and the final analysis will be performed at Week 52.

For controlling the probability of a Type I error for the primary and secondary efficacy endpoints at the final analysis, a hierarchical (sequential) multiple comparison procedure will be used, after applying the truncated Hochberg procedure for parallel gatekeeping.

Specifically:

- If both the interim and final results are significant (as described above), then at the final analysis the primary and secondary endpoints will be tested hierarchically using  $\alpha = 0.05$ .
- If either the interim or the final result, but not both, is significant, then at the final analysis the primary and secondary endpoints will be tested hierarchically using  $\alpha = 0.025$ .



If neither the interim nor the final result is significant, then at the final analysis the secondary endpoints will not be tested.

### **14.3 Immunogenicity**

Analysis of total and neutralizing antibody response and other immunological parameters will be primarily descriptive and involve both inter-subject and intra-subject comparisons.

### **14.4 Pharmacodynamic Analyses**

Plasma FVIII protein concentrations and FVIII activities determined over the course of the study will primarily be evaluated and summarized with descriptive statistical measures (eg, mean, standard deviation, CV%, min, median, max).

### **14.5 Safety Analysis**

The Medical Dictionary for Regulatory Activities terminology (MedDRA) will be used by the Sponsor to assign system organ class and preferred term classification to events and diseases, based on the original terms entered on the eCRF.

All AEs will be coded using the current version of MedDRA. The incidence of AEs will be summarized by system organ class, preferred term, relationship to study drug, and severity. A by-subject listing will be provided for those subjects who experience a serious AE (SAE), including death, or experience an AE associated with early withdrawal from the study or study drug.

Clinical laboratory data will be summarized by the type of laboratory test. For each clinical laboratory test, descriptive statistics will be provided on Baseline as well as all subsequent visits. Descriptive statistics for physical examination results and vital signs will also be provided.

Detailed statistical methods will be provided in the SAP.

### **14.6 Determination of Sample Size**

Seventy (70) subjects may be dosed in the study. The sample size for this study is based on clinical and statistical considerations in order to provide sufficient data to assess both safety and efficacy of BMN 270.

A sample size of 70 will provide at least 95% power to demonstrate that the change in hFVIII activity during Weeks 49-52 from baseline is greater than 0, assuming an effect size of 0.6, using a one-sample t-test with a 2-sided significance level of 0.025.



A sample size of 70 will provide at least 95% power to demonstrate that the change in the annualized utilization (IU/kg) of exogenous FVIII replacement therapy during Week 5 to Week 52 post-BMN 270 infusion from the baseline is less than 0, assuming an effect size of 0.6, using one-sample t-test with a 2-sided significance level of 0.025.

A sample size of 70 will also have at least 95% power to demonstrate that the change in the annualized number of bleeding episodes requiring exogenous FVIII replacement treatment (ABR) during Week 5 to Week 52 of the study post-BMN 270 infusion from the baseline ABR is less than 3.5 (non-inferiority margin), assuming the pre- and post-BMN 270 infusion population mean ABRs are 3.5 and 1 respectively, using a one-sample t-test with a 2-sided significance level of 0.025. Under the same assumptions, a sample size of 70 will have approximately 90% power to demonstrate that the change is less than 0, i.e. superiority of BMN 270 against FVIII prophylaxis.

Overall, a sample size of 70 will have greater than 80% power for testing the primary and secondary efficacy endpoints hierarchically at the final analysis with a 2-sided significance level of 0.025.

#### **14.7 Analysis Populations**

The efficacy analysis set will consist of all subjects who receive the BMN 270 infusion.

The safety population is the same as the efficacy analysis set.

#### **14.8 Changes in the Conduct of the Study or Planned Analyses**

Only BioMarin may modify the protocol. Any change in study conduct considered necessary by the Investigator will be made only after consultation with BioMarin, who will then issue a formal protocol amendment to implement the change. The only exception is when an Investigator considers that a subject's safety is compromised without immediate action. In these circumstances, immediate approval of the chairman of the IRB/IEC/REB must be sought, and the Investigator should inform BioMarin and the full IRB/IEC/REB within 2 working days after the emergency occurs.

With the exception of minor administrative or typographical changes, the IRB/IEC/REB must review and approve all protocol amendments. Protocol amendments that have an impact on subject risk or the study objectives, or require revision of the ICF, must receive approval from the IRB/IEC/REB prior to their implementation.

When a protocol amendment substantially alters the study design or the potential risks or burden to subjects, the ICF will be amended and approved by BioMarin and the IRB/IEC/REB, and all active subjects must again provide informed consent.



## 15 DATA MONITORING COMMITTEE

An independent DMC will be convened for this study. The duties of the DMC will include:

- Conducting an ongoing review of individual subject safety and efficacy data during the study.
- Recommending whether to enroll subjects at a different dose level (not to exceed 6E13 vg/kg) based on emerging data from 270-301 and the overall risk/benefit analysis of BMN 270.
- Reviewing ongoing safety and efficacy data for comparability of drug manufacturing lots within 270-301 and between 270-201 and 270-301.
- Making other recommendations on the conduct and reporting of the trial based on their evaluation of clinical data.

Details on the composition of the committee, frequency of meetings, and other committee functions and parameters are included in the DMC Charter and in the Statistical Analysis Plan (SAP).



## **16 COSTS, COMPENSATION, AND SUBJECT INJURY**

There will be no charge to study subjects to be in this study. BioMarin will pay all costs of tests, procedures, and treatments that are part of this study. In addition, after IRB/IEC/REB approval, BioMarin may reimburse the reasonable cost of travel for study-related visits in accordance with BioMarin's travel and reimbursement policy. BioMarin will not pay for any hospitalizations, tests, or treatments for medical problems of any sort related solely to the study subject's disease. Costs associated with such hospitalizations, tests, and treatments should be billed and collected in the way that such costs are usually billed and collected outside the study.

The Investigator should contact BioMarin immediately upon notification that a study subject has been injured by the study drug or by procedures performed as part of the study. Any subject who experiences a study-related injury should be instructed by the Investigator to seek immediate medical treatment at a pre-specified medical institution if possible, or at the closest medical treatment facility if necessary. The subject should be given the name of a person to contact to seek further information about, and assistance with, treatment for study-related injuries. The treating physician should bill the subject's health insurance company or other third party payer for the cost of this medical treatment. If the cost of the medical treatment is not covered by health insurance or another third party that usually pays these costs, then either BioMarin or the institution may pay for reasonable and necessary medical services to treat the injuries caused by the study drug or study procedures. In some jurisdictions, BioMarin is obligated by law to pay for study-related injuries without prior recourse to third party payer billing and/or regardless of fault. If this is the case, BioMarin will comply with the law.





---

## 17 CASE REPORT FORMS AND SOURCE DOCUMENTS

Electronic case report forms will be provided for each subject. The Investigator must review and electronically sign the completed eCRF casebook to verify its accuracy.

eCRFs must be completed using a web-based application developed and validated. Study site personnel will be trained on the application and will enter the clinical data from source documentation. Unless explicitly allowed in the eCRF instructions, blank data fields are not acceptable.

In the event of an entry error, or if new information becomes available, the value will be corrected by deselecting the erroneous response and then selecting or entering the factual response. In compliance with ICH GCP Guidelines and 21 CFR Part 11, the system will require the personnel making the correction to enter a reason for changing the value. The documented audit trail will include the reason for the change, the original value, the new value, the time of the correction and the identity of the operator.

BioMarin's policy is that study data on the eCRFs must be verifiable to the source data, which necessitates access to all original recordings, laboratory reports, and subject records. In addition, all source data should be attributable (signed and dated). The Investigator must therefore agree to allow direct access to all source data. Subjects must also allow access to their medical records, and subjects will be informed of this and will confirm their agreement when giving informed consent. If direct source document verification of study data by the site monitor is prohibited by institutional policy or local law, then the Investigator must make available facilities and/or personnel to allow GCP-compliant source verification to occur. Examples of such methods include certified copies of records which have study data visible but sensitive information redacted, or other GCP-compliant means agreed between the Investigator and the Sponsor.

A site monitor designated by BioMarin will compare the eCRFs with the original source documents at the study site and evaluate them for completeness and accuracy before designating them as "Source Data Verified" (SDV). If an error is discovered at any time or a clarification is needed, the site monitor, or designee, will create an electronic query on the associated field. Site personnel will then answer the query by either correcting the data or responding to the query. The site monitor will then review the response and determine either to close the query or re-query the site if the response does not fully address the question. This process is repeated until all open queries have been answered and closed.

Before a subject's eCRF casebook can be locked, data fields must be source data verified and all queries closed. Refer to the Study Monitoring Plan for details on which fields must be





---

source data verified. The Investigator will then electronically sign the casebook, specifying that the information on the eCRFs is accurate and complete. The Data Manager, or designee, will then set the status of the forms, visits, and the entire casebook to Locked. Upon completion of the CSR, an electronic copy of each site's casebooks will be copied to a compact disk (CD) and sent to each site for retention with other study documents.



## **18 STUDY MONITORING AND AUDITING**

Qualified individuals designated by BioMarin will monitor all aspects of the study according to GCP and standard operating procedures for compliance with applicable government regulations. The Investigator agrees to allow these monitors direct access to the clinical supplies, dispensing, and storage areas and to the clinical files, including original medical records, of the study subjects, and, if requested, agrees to assist the monitors. The Investigator and staff are responsible for being present or available for consultation during routinely scheduled site visits conducted by BioMarin or its designees.

Members of BioMarin's GCP Compliance Department or designees may conduct an audit of a clinical site at any time before, during, or after completion of the study. The Investigator will be informed if an audit is to take place and advised as to the scope of the audit. Representatives of the FDA or other Regulatory Agencies may also conduct an audit of the study. If informed of such an inspection, the Investigator should notify BioMarin immediately. The Investigator will ensure that the auditors have access to the clinical supplies, study site facilities, original source documentation, and all study files.



## 19 RETENTION OF RECORDS

The Investigator must retain all study records required by BioMarin and by the applicable regulations in a secure and safe facility. The Investigator must consult a BioMarin representative before disposal of any study records, and must notify BioMarin of any change in the location, disposition or custody of the study files. The Investigator /institution must take measures to prevent accidental or premature destruction of essential documents, that is, documents that individually and collectively permit evaluation of the conduct of a study and the quality of the data produced, including paper copies of study records (eg, subject charts) as well as any original source documents that are electronic as required by applicable regulatory requirements.

All study records must be retained for at least 2 years after the last approval of a marketing application in the US or an ICH region and until (1) there are no pending or contemplated marketing applications in the U.S. or an ICH region or (2) at least 2 years have elapsed since the formal discontinuation of clinical development of the IP. The Investigator /institution should retain subject identifiers for at least 15 years after the completion or discontinuation of the study. Subject files and other source data must be kept for the maximum period of time permitted by the hospital, institution or private practice, but not less than 15 years. These documents should be retained for a longer period, however, if required by the applicable regulatory requirements or by a BioMarin agreement. BioMarin must be notified and will assist with retention should Investigator /institution be unable to continue maintenance of subject files for the full 15 years. It is the responsibility of BioMarin to inform the Investigator /institution as to when these documents no longer need to be retained.



## **20 USE OF INFORMATION AND PUBLICATION**

BioMarin recognizes the importance of communicating medical study data and therefore encourages the publication of these data in reputable, peer-reviewed scientific journals and at seminars or conferences. The details of the processes of producing and reviewing reports, manuscripts, and presentations based on the data from this study will be described in the Clinical Trial Agreement between BioMarin and the Investigator/Institution. Consideration for authorship of all publications will be based on compliance with the Uniform Requirements for Manuscripts Submitted to Biomedical Journals (“Uniform Requirements”) of the International Committee of Medical Journal Editors (ICMJE) ([http://www.icmje.org/ethical\\_1author.html](http://www.icmje.org/ethical_1author.html)) and good publication practices (GPP).



---

## 21 REFERENCES

- Bainbridge, JW, Smith, AJ, Barker, SS, Robbie, S et. al. Effect of gene therapy on visual function in Leber's congenital amaurosis. *N Engl J Med* 358[21], 2231-2239. 2008.
- Batts KP & Ludwig J. Chronic hepatitis: an update on terminology and reporting. *Am J Surg Pathol* 19:1409-1417. 1995.
- Bedossa P, Pynard T, French METAVIR Cooperative Study Group. An algorithm for grading activity in chronic hepatitis C. *Hepatology* 24;289-293. 1996.
- Berntorp, E, Peake, I, Budde, U, Laffan, M et. al. von Willebrand's disease: a report from a meeting in the Aland islands. *Haemophilia* 18 Suppl 6, 1-13. 2012.
- Brooks R. EuroQol: the current state of play. *Health Policy*. 1996;37:53-72.
- Chai-Adisaksopha C, Skinner M, Curtis R, et al. Psychometric Properties of the Patient Reported Outcomes, Burdens and Experiences (PROBE) Questionnaire. *Blood*. 2017;130:5645.
- Croteau, GA, Martin, DB, Camp, J, Yost, M et. al. Evaluation of exposure and health care worker response to nebulized administration of tgAAVCF to patients with cystic fibrosis. *Ann Occup Hyg* 48[8], 673-681. 2004.
- D'Avola, D. Phase 1 Clinical Trial of Liver Directed Gene Therapy with rAAV5-PBGD in Acute Intermittent Porphyria: Preliminary Safety Data. *J Hepatol* 60[S58]. 2014.
- Den Ujil, Mauser Bunschoten, Roosendaal, Schutgens et. al. Clinical Severity of haemophilia A: does the classification of the 1950s still stand? *Haemophilia* 17, 849-853. 2011.
- EuroQol Group. EuroQol – a new facility for the measurement of health-related quality of life. *Health Policy*. 1990;16:199-208.
- George, LA, Sullivan, S, Teitel, J, Cuker, A et al. Preliminary results of a phase 1/2 trial of SPK-9001, a hyperactive FIX variant delivered by a novel capsid, demonstrate consistent factor IX activity levels at the lowest dose cohort. *Haemophilia* 22[Suppl. 4], 151-152. 2016.
- Hay, CR, DiMichele, DM. The principal results of the International Immune Tolerance Study: a randomized dose comparison  
12. *Blood* 119[6], 1335-1344. 2012.
- Haemo-QoL Study Group. Scoring Manual. Available at: <http://haemoqol.de/scoring/manual>. Last accessed 28 July 2017.



Kaufman, RJ, Powell, JS. Molecular approaches for improved clotting factors for hemophilia 1. *Blood* 122[22], 3568-3574. 2013.

Maguire, AM, High, KA, Auricchio, A, Wright, JF et. al. Age-dependent effects of RPE65 gene therapy for Leber's congenital amaurosis: a phase 1 dose-escalation trial. *Lancet* 374[9701], 1597-1605. 2009.

Mahlangu, J, Powell, JS, Ragni, MV, Chowdary, P et. al. Phase 3 study of recombinant factor VIII Fc fusion protein in severe hemophilia A 8. *Blood* 123[3], 317-325. 2014.

Manno, CS, Chew, AJ, Hutchison, S, Larson, PJ et. al. AAV-mediated factor IX gene transfer to skeletal muscle in patients with severe hemophilia B 1. *Blood* 101[8], 2963-2972. 2003.

Manno, CS, Pierce, GF, Arruda, VR, Glader, B et. al. Successful transduction of liver in hemophilia by AAV-Factor IX and limitations imposed by the host immune response. *Nat Med* 12[3], 342-347. 2006.

Mannucci, PM, Tuddenham, EG. The hemophilias--from royal genes to gene therapy 1. *N Engl J Med* 344[23], 1773-1779. 2001.

McIntosh, J, Lenting, PJ, Rosales, C, Lee, D et. al. Therapeutic levels of FVIII following a single peripheral vein administration of rAAV vector encoding a novel human factor VIII variant. *Blood* 121[17], 3335-3344. 2013.

Miesbach, W, Tangelder, M, Klamroth, R, Schutgens, R et al. Updated results from a dose escalating study in adult patients with haemophilia B with AMT-060 (AAV5-hFIX) gene therapy. *Haemophilia* 22[Suppl. 4], 151-152. 2016.

Mingozzi, F and High, KA. Immune responses to AAV vectors: overcoming barriers to successful gene therapy. *Blood* 122[1], 23-36. 2013.

Monahan, P, Walsh CE, Powell JS, Konkle BA et al. Update on a phase 1/2 open-label trial of BAX335, an adeno-associated virus 8 (AAV8) vector-based gene therapy program for hemophilia B. *J Thromb Haemostasis* 13[Suppl 2], 1-997. 2015.

Nagel, K, Walker, I, Decker, K, Chan, AK et. al. Comparing bleed frequency and factor concentrate use between haemophilia A and B patients 1. *Haemophilia* 17[6], 872-874. 2011.

Nathwani, AC, Gray, JT, Ng, CY, Zhou, J et. al. Self-complementary adeno-associated virus vectors containing a novel liver-specific human factor IX expression cassette enable highly



efficient transduction of murine and nonhuman primate liver

3. Blood 107[7], 2653-2661. 2006.

Nathwani, AC, McIntosh, J, Davidoff, AM. An update on gene therapy for hemophilia. *Curr Hematol Rep* 4[4], 287-293. 2005.

Nathwani, AC, Reiss, UM, Tuddenham, EG, Rosales, C et. al. Long-term safety and efficacy of factor IX gene therapy in hemophilia B. *N Engl J Med* 371[21], 1994-2004. 2014.

Nathwani, AC, Rosales, C, McIntosh, J, Rastegarlar, G et. al. Long-term safety and efficacy following systemic administration of a self-complementary AAV vector encoding human FIX pseudotyped with serotype 5 and 8 capsid proteins. *Mol Ther* 19[5], 876-885. 2011.

Nathwani, AC, Tuddenham, EG. *Epidemiology of coagulation disorders*. Baillieres Clin Haematol 5[2], 383-439. 1992.

Nathwani, AC, Tuddenham, EG, Rangarajan, S, Rosales, C et. al. Adenovirus-associated virus vector-mediated gene transfer in hemophilia B. *N Engl J Med* 365[25], 2357-2365. 2011.

Paneda, A, Lopez-Franco, E, Kaepfel, C, Unzu, C et. al. Safety and liver transduction efficacy of rAAV5-cohPBGD in nonhuman primates: a potential therapy for acute intermittent porphyria. *Hum Gene Ther* 24[12], 1007-1017. 2013.

Pasi, KJ, Rangarajan, S, Kim, B, et al. Achievement of Normal Circulating Factor VIII Activity Following BMN 270 AAV5-FVIII Gene Transfer: Interim, Long-Term Efficacy and Safety Results from a Phase 1/2 Study in Patients with Severe Hemophilia A. *Blood* 130[Suppl. 1], 603. 2017.

Reilly, M. WPAI Scoring. 2002. Available at: [http://www.reillyassociates.net/WPAI\\_Scoring.html](http://www.reillyassociates.net/WPAI_Scoring.html). Last accessed 28 July 2017.

Recht M, Neufeld EJ, Sharma VR, Solem CT et al. Impact of Acute Bleeding on Daily Activities of Patients with Congenital Hemophilia with Inhibitors and Their Caregivers and Families: Observations from the Dosing Observational Study in Hemophilia (DOSE). *Value in Health*. 2014;17:744-748.

Rentz A, Flood E, Altisent C, Bullinger M et al. Cross-cultural development and psychometric evaluation of a patient-reported health-related quality of life questionnaire for adults with haemophilia. *Haemophilia* 2008;14(5):1023-34.

Schenk-Braat, EA, van Mierlo, MM, Wagemaker, G, Bangma, CH et. al. An inventory of shedding data from clinical gene therapy trials. *J Gene Med* 9[10], 910-921. 2007.



---

Simonelli, F, Maguire, AM, Testa, F, Pierce, EA et. al. Gene therapy for Leber's congenital amaurosis is safe and effective through 1.5 years after vector administration. *Mol Ther* 18[3], 643-650. 2010.

Srivastava, A, Brewer, AK, Mauser-Bunschoten, EP, Key, NS et. al. Guidelines for the management of hemophilia 128. *Haemophilia* 19[1], e1-47. 2013.

Stonebraker, JS, Brooker, M, Amand, RE, Farrugia, A et. al. A study of reported factor VIII use around the world. *Haemophilia* 16[1], 33-46. 2010.

United States Department of Health and Human Services. Guidelines for the Use of Antiretroviral Agents in HIV-1-Infected Adults and Adolescents. 2014. Available at <https://aidsinfo.nih.gov/guidelines/html/1/adult-and-adolescent-arv-guidelines/458/plasma-hiv-1-rna--viral-load--and-cd4-count-monitoring>. Last accessed 28 July 2017.

Van Genderen FR, Westers P, Heijnen L, De Kleijn P et al. Measuring patients' perceptions on their functional abilities: validation of the Haemophilia Activities List. *Haemophilia*. 2006;12:36-46.

Watkins, PB, Kaplowitz, N, Slattery, JT, Colonese, CR et al. Aminotransferase Elevations in Healthy Adults Receiving 4 Grams of Acetaminophen Daily: A Randomized Controlled Trial. *JAMA* 296[1], 87-93. 2006.

White, GC, Rosendaal, F, Aledort, FM, Lusher, JM et al. Definitions in hemophilia. Recommendation of the scientific subcommittee on factor VIII and factor IX of the scientific and standardization committee of the International society on Thrombosis and Haemostasis. *Thromb Haemost.* 85[3], 560. 2001.





---

## 22 INVESTIGATOR RESPONSIBILITIES

### 22.1 Conduct of Study and Protection of Human Patients

In accordance with FDA Form 1572 and/or principles of ICH E6 GCP, the Investigator will ensure that:

- He or she will conduct the study in accordance with the relevant, current protocol and will only make changes in a protocol after notifying the sponsor, except when necessary to protect the safety, rights, or welfare of subjects.
- He or she will personally conduct or supervise the study.
- He or she will inform any potential subjects, or any persons used as controls, that the drugs are being used for investigational purposes, and he or she will ensure that the requirements relating to obtaining informed consent in 21 CFR Part 50 and/or ICH E6 sections 2.9 and 4.8 are met. As well, he or she will ensure that IRB/IEC review and approval in 21 CFR Part 56 and/or ICH E6 section 2.6 are met.
- He or she will report to the sponsor adverse experiences that occur in the course of the investigation in accordance with 21 CFR 312.64 and/or ICH E6 Section 4.11.
- He or she has read and understands the information in the Investigator's Brochure, including potential risks and side effects of the drug.
- His or her staff and all persons who assist in the conduct of the study are informed about their obligations in meeting the above commitments
- Adequate and accurate records in accordance with 21 CFR 312.62 and/or ICH E6 section 4.9 are kept, and those records are available for inspection in accordance with 21 CFR 312.68 and/or ICH E6 section 4.9.7.
- The IRB/EC/REB complies with the requirements of 21 CFR Part 56, ICH E6 Section 3.0, and other applicable regulations, and conducts initial and ongoing reviews and approvals of the study. He or she will also ensure that any change in research activity and all problems involving risks to human subjects or others are reported to the IRB/EC/REB. Additionally, he or she will not make any changes in the research without IRB/EC/REB approval, except where necessary to eliminate apparent immediate hazards to human subjects.
- He or she agrees to comply with all other requirements regarding the obligations of clinical Investigators and all other pertinent requirements in 21 CFR Part 312 and/or ICH E6.



**23 SIGNATURE PAGE**

**Protocol Title:** A Phase 3 Open-Label, Single Arm Study To Evaluate The Efficacy and Safety of BMN 270, an Adenovirus-Associated Virus Vector-Mediated Gene Transfer of Human Factor VIII in Hemophilia A Patients with Residual FVIII Levels  $\leq$  1 IU/dL Receiving Prophylactic FVIII Infusions

**Protocol Number:** 270-301 Amendment 1

I have read the forgoing protocol and agree to conduct this study as outlined. I agree to conduct the study in compliance with all applicable regulations and guidelines, including ICH E6, as stated in the protocol, and other information supplied to me.

\_\_\_\_\_  
Investigator Signature Date

Printed name: \_\_\_\_\_

**Accepted for the Sponsor:**



\_\_\_\_\_  
Medical Monitor Signature Date

Printed name: **PI** \_\_\_\_\_ Clinical Sciences \_\_\_\_\_



## 24 PROTOCOL AMENDMENT TEXT REVISIONS

The following table summarizes the revisions made to the protocol and relates the changes to the appropriate rationale (see pages 2-4). Added text is indicated by underlined font and deleted text is indicated by ~~strike through~~ font.

| Section No./Title                  | Revision   | Rationale    |
|------------------------------------|--|--------------|
| 2/Synopsis (Study Sites)           | Approximately <del>3040</del> sites worldwide.   | 14           |
| 2/Synopsis (Study Rationale)       | <p><u>Figure 1: hFVIII-SQ Vector Genome Schematic has been updated</u></p> <p>BMN 270 is currently being evaluated in clinical study 270-201, an ongoing first-in-human, phase 1/2 dose escalation study in subjects with severe HA designed to assess the safety and efficacy of BMN 270 at various dose levels (6E12 vg/kg, 2E13 vg/kg, 4E13 vg/kg, 6E13 vg/kg). Specifically, 270-201 explores the relationship of vector dose to the augmentation of residual FVIII activity and whether these levels are sufficient to alter the clinical phenotype. Preliminary results from 270-201 have demonstrated that following gene transfer, FVIII activity above <del>5%</del> <u>(15 IU/dL)</u> and, in many cases, within the normal range for FVIII, is achievable <del>at doses</del> <u>with a dose</u> of 4-6E13 vg/kg with an acceptable safety profile (Pasi, <del>2016</del>, <u>Haemophilia</u> 2017, Blood).</p> <p>The current study is a Phase 3, single-arm, open-label study designed to assess whether, in an expanded sample, BMN 270 can safely alter the clinical phenotype of hemophilia A patients with residual FVIII activity <math>\leq 1</math> IU/dL, with an altered phenotype defined as achieving FVIII activity of <math>\geq</math> <del>5%</del> <u>(15 IU/dL)</u>.</p> | 16, 17       |
| 2/Synopsis (Objectives)            | <p>The primary efficacy <del>objectives</del> <u>objective</u> of the study <del>are</del> <u>is</u> to:</p> <ul style="list-style-type: none"> <li>Assess the efficacy of BMN 270 defined as <del>median</del> <u>FVIII activity, as measured by one-stage clotting assay</u>, during Weeks <del>48-52</del> <u>49-52</u> following intravenous infusion of BMN 270</li> </ul>  | 17           |
| 2/Synopsis (Study Design and Plan) | This is a Phase 3, single-arm, open-label study in hemophilia A patients with residual FVIII levels $\leq 1$ IU/dL treated continuously with prophylactic exogenous FVIII for a minimum of one year prior to enrollment. Subjects will be enrolled at approximately <del>3040</del> sites worldwide. Subjects must have high-quality, well-documented historical data available concerning previous bleeding episodes and exogenous FVIII usage over the previous 12 months in order to be eligible to enroll in the study.  | 1, 2, 14, 17 |



| Section No./Title                       | Revision  | Rationale |
|---|---|-----------|
|   | <p>Approximately <del>4070</del> adult subjects <u>with severe HA</u> will receive a 6E13 vg/kg dose of BMN 270 as <del>ana single</del> intravenous infusion. <u>Approximately 20 subjects will enroll in the study with at least 12 months of well-documented high-quality historical data concerning previous bleeding episodes and exogenous FVIII usage, while approximately 50 subjects will enroll in the study after having completed at least 6 months' participation in the BioMarin-sponsored non-interventional study 270-902.</u></p> <p><u>Study Schematic Figure has been added</u></p> <p>The Data Monitoring Committee (DMC) will review available safety and efficacy (eg, FVIII activity) data during the study on an ongoing basis and may determine, based on emerging data and the risk/benefit profile, that further enrollment at 6E13 vg/kg should be discontinued in favor of a <u>lower different</u> dose of BMN 270, <u>not to exceed 6E13 vg/kg</u>. If the DMC recommends a dosing modification, then additional subjects may be enrolled, up to a total of approximately <del>4070</del> subjects, at the new BMN 270 dose level (regardless of the number of subjects previously enrolled at 6E13 vg/kg).</p> <p>An interim analysis <u>will be performed after all is planned when</u> <del>after 20 treated</del> subjects have <del>been followed for</del> <u>completed the Week 26 weeks post-BMN 270 infusion visit.</u></p> |           |
| 2/Synopsis (Number of Subjects Planned) | Approximately <del>4070</del> subjects may enroll into the study.   | 1         |
| 2/Synopsis (I/E Criteria)               | <p><del>Participants</del> <u>Patients</u> are eligible to be included in the study only if all of the following criteria apply:</p> <p>6. Sexually active participants must agree to use an acceptable method of <u>effective contraception--double barrier contraception (ie, condom + diaphragm; or condom or diaphragm + spermicidal gel or foam) or their female partner either using hormonal contraceptives or having an intrauterine device--for at least 6 months post-infusion, which may include hormonal contraception for a female partner.</u> After 6 months, subjects may stop contraception use only if they have had 3 consecutive semen samples with no detectable viral vector DNA.</p> <p><del>Participants</del> <u>Patients</u> are excluded from the study if any of the following criteria apply:</p> <p>15. Treatment with any investigational product within 30 days <u>or 5 half-lives of the investigational product</u> prior to the screening period. For subjects who have received a prior investigational product, all ongoing adverse events (AEs) experienced while receiving that investigational product must have resolved prior to screening for this study.</p>  | 15, 17    |



| Section No./Title                    | Revision   | Rationale |
|--------------------------------------|--|-----------|
| 2/Synopsis (Criteria for Evaluation) | <p><u>Efficacy:</u></p> <p>Primary efficacy <del>endpoints</del>endpoint:</p> <ul style="list-style-type: none"> <li>Change of the <del>median</del> hFVIII activity, as measured by one-stage clotting assay, during Weeks <del>48</del>49-52 post-BMN 270 infusion from baseline <del>using a validated assay</del>. Each subject's hFVIII activity during Weeks 49-52 is defined as the median of the values obtained during this 4-week window. Values for hFVIII activity will be excluded if obtained within 72 hours since the last infusion of exogenous FVIII protein concentrates <del>(or 5x the known half life of the FVIII concentrates administered)</del>.</li> </ul> <p>Secondary efficacy endpoints:</p> <ul style="list-style-type: none"> <li>Change in the annualized number of bleeding episodes requiring exogenous FVIII replacement treatment (<u>annualized bleeding rate, ABR</u>) during Week 5 to Week 52 of the study post-BMN 270 infusion from the baseline ABR calculated using subjects' historical medical records during the year prior to enrollment.</li> </ul> <p>Tertiary efficacy endpoints:</p> <ul style="list-style-type: none"> <li><u>Change from baseline in Patient Reported Outcomes, Burdens, and Experiences (PROBE) score at Week 52 of the study post-BMN 270 infusion.</u></li> </ul> <p><u>Safety:</u></p> <p>Each subject will have comprehensive surveillance monitoring of LFTs (once per week for Weeks 1-36, and then once every 2 weeks from Weeks 37-52) during Year 1. LFTs will be monitored every <del>three months for up to</del> <u>four weeks during Year 2 and then every 6 weeks during Years 3-5 years</u> post-dose in the safety extension; the frequency and duration of LFT testing may be changed based on discussion between the Medical Monitor and the Investigator, review of subject data, and/or by independent DMC feedback.</p> | 7, 9, 17  |
| 2/Synopsis (Statistical Methods)     | <p><u>Sample Size</u></p> <p><del>Forty (40)</del> <u>Seventy (70)</u> subjects may be dosed in the study. <del>Assuming a rate of subject discontinuation of up to 15%, a sample size of 40</del> <u>The sample size for this study is based on clinical and statistical considerations in order to provide sufficient data to assess both safety and efficacy of BMN 270.</u></p> <p><u>A sample size of 70 will provide at least 90%</u> <del>90</del> <u>95%</u> power to demonstrate that the change in <del>median</del> hFVIII activity <del>at</del> <u>during</u> Weeks <del>48</del>49-52 from baseline is <del>statistically significant</del> <u>greater than 0</u>, assuming an effect size of 0.6, using a one-sample t-test with <del>an</del> <u>a</u> 2-sided significance level of 0.049. <del>The sample size of 40</del> <u>25</u>.</p>  | 1, 2, 17  |



| Section No./Title | Revision  | Rationale |
|-------------------|---|-----------|
|                   | <p><u>A sample size of 70 will provide at least 95% power to demonstrate that the change in the annualized utilization (IU/kg) of exogenous FVIII replacement therapy during Week 5 to Week 52 post-BMN 270 infusion from baseline is less than 0, assuming an effect size of 0.6, using a one-sample t-test with a 2-sided significance level of 0.025.</u></p> <p><u>A sample size of 70 will also have at least 90% power for hypothesis 95% power to demonstrate that the change in the annualized number of bleeding episodes requiring exogenous FVIII replacement treatment (ABR) during Week 5 to Week 52 of the study post-BMN 270 infusion from the baseline ABR is less than 3.5 (non-inferiority margin), assuming the pre- and post-BMN 270 infusion population mean ABRs are 3.5 and 1 respectively, using a one-sample t-test with a 2-sided significance level of 0.025. Under the same assumptions, a sample size of 70 will have approximately 90% power to demonstrate that the change is less than 0, i.e. superiority of BMN 270 against FVIII prophylaxis.</u></p> <p><u>Overall, a sample size of 70 will have greater than 80% power for testing of each of the primary and secondary efficacy endpoints hierarchically at the final analysis with a 2-sided significance level of 0.025.</u></p> <p><u>Analysis Population</u></p> <p><u>The efficacy analysis set will be comprised of all subjects who have received BMN 270 infusion.</u><br/> <del>The safety population will consist of all subjects who receive BMN 270 infusion during the study.</del><br/> <u>The safety population is the same as the efficacy analysis set.</u></p> <p><u>Analysis</u></p> <p><u>For the primary efficacy endpoint at Week 52 (ie, the change in the median hFVIII activity during Weeks 48-52 post-BMN 270 infusion from baseline, as measured by one-stage clotting assay), a one-sample t-test will be used to test the null hypothesis that the change is 0 or less against the alternative hypothesis that the change is greater than 0. Descriptive summaries of the proportions of subjects whose FVIII activity during Weeks 49-52 is greater than or equal to select thresholds, such as 15, 25 and 30 IU/dL, and the confidence intervals of the proportions will also be provided. The FVIII activity as measured by chromogenic assay will be analyzed similarly, as a supportive analysis.</u></p> <p><u>For the first secondary efficacy endpoint at Week 52 (ie, the change in the annualized utilization (IU/kg) of exogenous FVIII replacement therapy during Weeks 5-52 post-BMN 270 infusion from baseline), a one-sample t-test will be performed to test the null hypothesis that the change is 0 or greater against the alternative hypothesis that the change is less than 0.</u></p> <p><u>For the second secondary efficacy endpoint at Week 52 (ie, the change in the annualized number of bleeding episodes requiring exogenous FVIII replacement treatment during Weeks 5-52 post-BMN 270 infusion from baseline), a one-sample t-test will be performed to test for non-inferiority of BMN 270 against FVIII prophylaxis using a margin of 3.5 (ie, the baseline ABR calculated using subjects' historical medical records during the year prior to enrollment) using a margin of 3.5, i.e. to</u></p> |           |



| Section No./Title   | Revision  | Rationale |
|---------------------|---|-----------|
|                     | <p><u>test the null hypothesis that the change is 3.5 or greater against the alternative hypothesis that the change is less than 3.5. If non-inferiority is demonstrated, the test for superiority of BMN 270 against FVIII prophylaxis will be performed.</u></p> <p><u>The primary efficacy endpoint and secondary efficacy endpoints will be tested sequentially/hierarchically at the final analysis at Week 52 according to the order described above.</u></p> <p><u>An interim analysis is planned <del>when after all 4020</del> treated subjects have completed the Week 26 visit (or have discontinued study participation prior to Week 26). The primary efficacy endpoint for the interim analysis is change in the median hFVIII activity, as measured by one-stage clotting assay, during Weeks <del>22</del>23-26 post-BMN 270 infusion from baseline. The secondary efficacy endpoints for the interim analysis will be defined as follows: Change in the annualized utilization (IU/kg) of exogenous FVIII replacement therapy. Each subject's hFVIII activity during Weeks <del>5-26</del>23-26 is defined as the median of the values obtained during this 4-week window. Values for hFVIII activity will be excluded if obtained within 72 hours since the last infusion from baseline. Change in the annualized number of bleeding episodes requiring exogenous/exogenous FVIII protein concentrates. A 2-sided one-sample t-test will be used to test the null hypothesis that the change is 0 or less against the alternative hypothesis that the change is greater than 0. In addition, subjects' hFVIII activity post-Week 23, defined as the median of the values obtained from Week 23 to the time of last follow-up, will be analyzed similarly as an important sensitivity analysis, utilizing additional data beyond Week 26. Descriptive summaries of the proportions of subjects whose FVIII replacement treatment activity during Weeks <del>5-26</del>23-26 post-BMN 270 infusion from baseline (tested first for non inferiority using a margin of 3.5 and then for superiority). The primary <del>23-26</del> and from Week 23 to the time of last follow-up is greater than or equal to select thresholds, such as 15, 25 and secondary efficacy hypotheses at the interim analysis will be tested sequentially according to the order described above 30 IU/dL, and the confidence intervals of the proportions will be provided, respectively. The FVIII activity as measured by chromogenic assay will be analyzed similarly, as a supportive analysis.</u></p> <p><u>The <del>Bonferroni</del>Hochberg procedure will be used to adjust for multiplicity using <del>alpha=0.001 at</del> of the interim analysis at Week 26 and <del>alpha=0.049 at</del> the final analysis.</u></p> <p><u>However, at Week 52 of the primary efficacy endpoint. (Regardless of the interim analysis results, the study will continue, and the final analysis will be performed at Week 52.) At the final analysis at Week 52, the secondary efficacy endpoints will be tested hierarchically; the level of significance will be determined by the truncated Hochberg procedure for parallel gatekeeping.</u></p> <p><u>The secondary efficacy endpoints at the interim analysis (Week 26) will be summarized descriptively.</u></p> |           |
| 7.3/Study Rationale | <u>Figure 7.3.1: hFVIII-SQ Vector Genome Schematic has been updated</u>   | 16, 17    |





| Section No./Title                         | Revision  | Rationale    |
|---|---|--------------|
|   | <p>BMN 270 is currently being evaluated in clinical study 270-201, an ongoing first-in-human, phase 1/2 dose escalation study in subjects with severe HA designed to assess the safety and efficacy of BMN 270 at various dose levels (6E12 vg/kg, 2E13 vg/kg, 4E13 vg/kg, 6E13 vg/kg). Specifically, 270-201 explores the relationship of vector dose to the augmentation of residual FVIII activity and whether these levels are sufficient to alter the clinical phenotype. Preliminary results from 270-201 have demonstrated that following gene transfer, FVIII activity above <del>5%</del> <u>515% (15 IU/dL)</u> and, in many cases, within the normal range for FVIII, is achievable <del>at doses</del> <u>with a dose</u> of 4-6E13 vg/kg with an acceptable safety profile (Pasi, 2016, <del>Haemophilia</del> 2017, Blood). For additional information on preliminary data in 270-201, refer to the current version of the <u>Investigator's Brochure</u>.</p> <p>The current study is a Phase 3, single-arm, open-label study designed to assess whether, in an expanded sample, BMN 270 can safely alter the clinical phenotype of hemophilia A patients with residual FVIII activity <math>\leq 1</math> IU/dL, with an altered phenotype defined as achieving FVIII activity of <math>\geq</math> <del>5%</del> <u>515% (<math>\geq 15</math> IU/dL)</u>.</p> |              |
| 7.4/Summary of Overall Risks and Benefits | The majority of subjects in the ongoing 270-201 clinical study who have received 4E13 or 6E13 vg/kg doses of BMN 270 have had Grade 1 asymptomatic elevations in ALT. For most subjects, the elevations have reached only slightly above the ULN. Based on the effectiveness of transient oral corticosteroid <del>used</del> <u>used</u> to suppress a presumed <del>Class 1 (cytotoxic T-cell)</del> response <del>to hepatocytes transduced</del> in prior studies with hepatic transduction with AAV vectors (Mingozzi, 2013), subjects were treated with 7-32 weeks of oral corticosteroids preventatively or in response to the elevations in ALT to ensure preservation of the transduced hepatocytes.   | 17           |
| 8/Study Objectives                        | The primary efficacy <del>objectives</del> <u>objective</u> of the study <del>are</del> <u>is</u> to: <ul style="list-style-type: none"> <li>Assess the efficacy of BMN 270 defined as <del>median</del> <u>median</u> FVIII activity, <u>as measured by one-stage clotting assay</u>, during Weeks <del>48</del> <u>49</u>-52 following intravenous infusion of BMN 270</li> </ul>   | 17           |
| 9.1/Overall Study Design and Plan         | <p>This is a Phase 3, single-arm, open-label study in hemophilia A patients with residual FVIII levels <math>\leq 1</math> IU/dL treated continuously with prophylactic exogenous FVIII for a minimum of one year prior to enrollment. Subjects will be enrolled at approximately <del>30</del> <u>40</u> sites worldwide. Subjects must have high-quality, well-documented historical data available concerning previous bleeding episodes and exogenous FVIII usage over the previous 12 months in order to be eligible to enroll in the study.</p> <p>Approximately <del>40</del> <u>70</u> adult subjects <u>with severe HA</u> will receive a 6E13 vg/kg dose of BMN 270 as <del>an</del> <u>a</u> single intravenous infusion. <u>Approximately 20 subjects will enroll in the study with at least 12 months of well-documented high-quality historical data concerning previous bleeding episodes and exogenous FVIII usage, while approximately 50 subjects will enroll</u></p>   | 1, 2, 14, 17 |





| Section No./Title               | Revision  | Rationale         |
|---------------------------------|---|-------------------|
|                                 | <p><u>in the study after having completed at least 6 months' participation in the BioMarin-sponsored non-interventional study 270-902.</u></p> <p><u>Study Schematic Figure has been added</u></p> <p>The Data Monitoring Committee (DMC) will review available safety and efficacy (eg, FVIII activity) data during the study on an ongoing basis and may determine, based on emerging data and the risk/benefit profile, that further enrollment at 6E13 vg/kg should be discontinued in favor of a lower <u>different</u> dose of BMN 270-, <u>not to exceed 6E13 vg/kg.</u> If the DMC recommends a dosing modification, then additional subjects may be enrolled, up to a total of approximately <u>4070</u> subjects, at the new BMN 270 dose level (regardless of the number of subjects previously enrolled at 6E13 vg/kg).</p> <p><u>An interim analysis is planned <del>when</del> after 20 treated subjects have completed the Week 26 visit.</u></p>  |                   |
| Table 9.1.1 through Table 9.1.4 | The Schedules of Events have been updated to be consistent with other changes made to the protocol.   | 4, 5, 6, 7, 9, 17 |
| Table 9.1.1 (Footntoes)         | <p><sup>f</sup> <u>Includes HLA genotyping, and FVIII genotyping, <del>TNF-α and IL10a single nucleotide polymorphisms.</del></u></p> <p><sup>g</sup> <u>Blood samples will be collected <del>from subjects</del> to evaluate biochemical, molecular, cellular, and genetic/genomic aspects relevant to hemophilia A <del>disease</del>, coagulation, and/or AAV gene transfer, and to develop assays used for these evaluations. Subjects may choose to opt out of the exploratory genetic/genomic research being done to study or try to discover genes that are not yet known to be associated with hemophilia A. While exploratory samples will be collected at the time points indicated above, testing <del>on these samples is optional</del> of these samples (including those for TGA assay, Direct Thrombin Activity test, and any other exploratory assessments) will be performed only as deemed necessary by the Sponsor.</u></p> <p><sup>k</sup> <u>With the exception of the collection of samples for PCR vector DNA analysis, assessments on the day of infusion must be performed prior to the infusion. On the day of the BMN 270 Infusion, vital signs will be monitored prior to the infusion, during the infusion every 15 minutes (± 5 minutes), and following the infusion hourly (± 5 minutes) for at least 8 hours during the subject's stay in the clinic. Shedding samples for PCR of vector DNA analysis (blood, saliva, urine, semen, stool) should be collected between 2 and 24 hours after the infusion has been completed.</u></p> <p><sup>m</sup> <u>While the transduction inhibition assays will be run at Screening, they will not be used to determine inclusion/exclusion from the study.</u></p> | 3, 4, 17          |



| Section No./Title          | Revision   | Rationale |
|----------------------------|--|-----------|
| Table 9.1.2<br>(Footnotes) | <p><sup>c</sup> Includes FVIII activity level (chromogenic FVIII assay and one-stage clot FVIII assay), Bethesda assay (with Nijmegen modification) for hFVIII inhibitor level, coagulation exploratory assay, and hFVIII protein assay. <u>If a subject has used FVIII within 72 hours of a measurement day, all efforts should be made to obtain FVIII activity measurements when a 72-hour interval without FVIII use is achieved; the 72-hour wash-out period is only intended for subjects who have achieved FVIII <math>\geq</math> 5 IU/dL at 16 weeks after BMN 270 infusion and who have not resumed FVIII replacement therapy.</u> If FVIII levels are elevated or stable over the course of several weeks, assessment of FVIII activity may be adjusted based on discussion between the Medical Monitor and the Investigator. A D-dimer may be considered under circumstances in which FVIII activity levels are above the normal physiological range and/or if there is a concern for a venous thromboembolism.</p> <p><sup>d</sup> Collection <u>for each matrix</u> to occur until at least 3 consecutive negative results are obtained. Collection and testing of semen samples must continue at least through Week 12, even if 3 consecutive negative results in that compartment have already been recorded.</p> <p><sup>e</sup> Blood samples will be collected <del>from subjects</del> to evaluate biochemical, molecular, cellular, and genetic/genomic aspects relevant to hemophilia A <del>disease</del>, coagulation, and/or AAV gene transfer, and to develop assays used for these <u>evaluations. Subjects may choose to opt out of the exploratory genetic/genomic research being done to study or try to discover genes that are not yet known to be associated with hemophilia A. While exploratory samples will be collected at the time points indicated above, testing on these samples is optional.</u> of these samples (including those for TGA assay, Direct Thrombin Activity test, and any other exploratory assessments) will be performed only as deemed necessary by the Sponsor.</p> | 3, 17     |
| Table 9.1.3<br>(Footnotes) | <p><sup>c</sup> Includes FVIII activity level (chromogenic FVIII assay and one-stage clot FVIII assay), Bethesda assay (with Nijmegen modification) for hFVIII inhibitor level, coagulation exploratory assay, and hFVIII protein-. <u>If a subject has used FVIII within 72 hours of a measurement day, all efforts should be made to obtain FVIII activity measurements when a 72-hour interval without FVIII use is achieved; the 72-hour wash-out period is only intended for subjects who have achieved FVIII <math>\geq</math> 5 IU/dL at 16 weeks after BMN 270 infusion and who have not resumed FVIII replacement therapy.</u> If FVIII levels are elevated or stable over the course of several weeks, assessment of FVIII activity may be adjusted based on discussion between the Medical Monitor and the Investigator. A D-dimer may be considered under circumstances in which FVIII activity levels are above the normal physiological range and/or if there is a concern for a venous thromboembolism.</p> <p><sup>d</sup> Collection <u>for each matrix</u> to occur until at least 3 consecutive negative results are obtained.</p>  | 3, 17     |



| Section No./Title          | Revision   | Rationale    |
|----------------------------|--|--------------|
|                            | <p><sup>e</sup> Blood samples will be collected <del>from subjects</del> to evaluate biochemical, molecular, cellular, and genetic/genomic aspects relevant to hemophilia A <del>disease</del>, coagulation, and/or AAV gene transfer, and to develop assays used for these evaluations. <u>Subjects may choose to opt out of the exploratory genetic/genomic research being done to study or try to discover genes that are not yet known to be associated with hemophilia A. While exploratory samples will be collected at the time points indicated above, testing on these samples of these samples (including those for TGA assay, Direct Thrombin Activity test, and any other exploratory assessments) will be performed only as deemed necessary by the Sponsor.</u></p>  |              |
| Table 9.1.4<br>(Footnotes) | <p>* Visit windows are <math>\pm</math> 48 hours through Week 36, then <math>\pm</math>1 week until Week 52 and <math>\pm</math> 2 weeks for visits in Years 2-5. <u>For LFT and FVIII testing during Years 2-5, the visit windows are every 4 weeks (+ 2 weeks, or to align with the Q3M visits) during Year 2, and every 6 weeks (<math>\pm</math>2 weeks) during Years 3-5.</u></p> <p><sup>c</sup> Includes FVIII activity level (chromogenic FVIII assay and one-stage clot FVIII assay), Bethesda assay (with Nijmegen modification) for hFVIII inhibitor level, coagulation exploratory assay, and hFVIII protein assay. <u>If a subject has used FVIII within 72 hours of a measurement day, all efforts should be made to obtain FVIII activity measurements when a 72-hour interval without FVIII use is achieved; the 72-hour wash-out period is only intended for subjects who have achieved FVIII <math>\geq</math> 5 IU/dL at 16 weeks after BMN 270 infusion and who have not resumed FVIII replacement therapy. If FVIII levels are elevated or stable over the course of several weeks, assessment of FVIII activity may be adjusted based on discussion between the Medical Monitor and the Investigator. A D-dimer may be considered under circumstances in which FVIII activity levels are above the normal physiological range and/or if there is a concern for a venous thromboembolism. <u>If a subject tests positive in the Bethesda assay (with Nijmegen modification) during Years 3-5, a fresh sample should be collected within 4 weeks of the initial visit that had a positive result.</u></u></p> <p><sup>d</sup> Sample testing during Long-Term Follow-Up is not required if at least 3 consecutive samples <del>are cleared</del> <u>were negative</u> during the Post-Infusion Follow-Up period. Subjects who have not had 3 consecutive negative semen samples by Week 52 should continue to have PCR testing of semen every 4 weeks until 3 consecutive negative samples are documented (or upon consultation between the Investigator and Medical Monitor).</p> <p><sup>e</sup> Blood samples will be collected <del>from subjects</del> to evaluate biochemical, molecular, cellular, and genetic/genomic aspects relevant to hemophilia A <del>disease</del>, coagulation, and/or AAV gene transfer, and to develop assays used for these evaluations. <u>Subjects may choose to opt out of the exploratory genetic/genomic research being done to study or try to discover genes that are not yet known to be associated with hemophilia A. While exploratory samples will be collected at the</u></p> | 3, 7, 10, 17 |



| Section No./Title                            | Revision  | Rationale |
|--|---|-----------|
|  | <del>time points indicated above, testing on these samples is optional.</del> <u>of these samples (including those for TGA assay, Direct Thrombin Activity test, and any other exploratory assessments) will be performed only as deemed necessary by the Sponsor.</u>  |           |
| 9.2/Discussion of Study Design               | Approximately <del>4070</del> subjects will be enrolled at the 6E13 vg/kg BMN 270 dose. Subjects will be followed for 52 weeks post-BMN 270 infusion during which safety and efficacy assessments will be taken. After the final analysis at 52 weeks post-infusion, safety and efficacy will then continue to be assessed long-term for approximately a total of 5 years. During enrollment, the DMC will review available safety and efficacy data on an ongoing basis and may decide to recommend dosing subjects at a <del>lower</del> <u>different</u> dose level <u>(not to exceed 6E13 vg/kg)</u> based on emerging data from 270-301 and their overall benefit:risk assessment.   | 1         |
| 9.3/Selection of Study Population            | Approximately <del>4070</del> <u>adult</u> hemophilia A patients with residual FVIII levels $\leq$ 1 IU/dL may enroll into the study.   | 1, 17     |
| 9.3.1/Inclusion Criteria                     | Individuals eligible to participate in this study must meet all of the following inclusion criteria:<br><br>6. Sexually active participants must agree to use an acceptable method of <u>effective contraception--double barrier contraception (i.e., condom + diaphragm; or condom or diaphragm + spermicidal gel or foam) or their female partner either using hormonal contraceptives or having an intrauterine device--for at least 6 months post-infusion, which may include hormonal contraception for a female partner.</u> After 6 months, subjects may stop contraception use only if they have had 3 consecutive semen samples with no detectable viral vector DNA.<br><br>Individuals who meet any of the following exclusion criteria will not be eligible to participate in the study:<br><br>15. Treatment with any investigational product within 30 days <u>or 5 half-lives of the investigational product</u> prior to the screening period. For subjects who have received a prior investigational product, all ongoing adverse events (AEs) experienced while receiving that investigational product must have resolved prior to screening for this study. | 15, 17    |
| 9.4.2.1/Product Characteristics and Labeling | BMN 270 is a sterile, clear, colorless-to-pale yellow solution for IV infusion and is supplied in a <del>210 mL polypropylene cryovial</del> <u>Crystal Zenith® (CZ) vial</u> . Each vial contains <del>1.18.5</del> <u>1.18.5</u> mL of AAV5-hFVIII-SQ at a concentration of 2E13 vector genomes per mL in a pH 7.4 phosphate buffer.<br><br><del>The study drug label includes the following information: lot number, required storage conditions, a precautionary statement, expiry date, study number, and BioMarin name and address. Labelling will be done according to follows country specific requirements.</del>  | 13        |



| Section No./Title                                      | Revision   | Rationale |
|--|--|-----------|
| 9.4.4/Directions for Administration                    | Following completion of the infusion, vital signs will be monitored hourly ( $\pm$ 5 minutes). If the vital signs are stable the catheter will be removed 8 hours after the infusion. Hemostasis at the puncture site will be established by applying pressure according to standard protocol for infusing FVIII concentrates. Subjects will remain in the clinic for at least 8 hours to observe for any immediate toxicity of the procedure; in-patient observation can be extended beyond 8 hours if needed per Investigator discretion. <del>After 8 hours, participants will be discharged from the clinic unless toxicity has been observed in which case the stay in the clinic may be extended,</del> or the subject may transfer to a separate facility based on the evaluation and judgment of the Principal Investigator after consultation with the Medical Monitor. | 17        |
| 9.4.5/Method of Assigning Subjects to Treatment Groups | Approximately <del>4070</del> subjects will be enrolled at 6E13 vg/kg.   | 1         |
| 9.4.6/Selection of Dose                                | In order to further evaluate the dose-response relationship of BMN 270, subjects will be enrolled at a dose of 6E13 vg/kg. This dose is expected to be safe and effective based on clinical experience to date in 270-201. The DMC will review emerging safety and efficacy data and may recommend that a <del>lower</del> <u>different</u> dose ( <u>not to exceed 6E13 vg/kg</u> ) be administered. In such a case, up to <del>4070</del> additional subjects may be enrolled at the new dose.   | 1         |
| 9.4.8/Prior and Concomitant Medications                | The following medications are prohibited starting 30 days before Screening and through the end of the study, and the Sponsor must be notified if a subject receives any of these during the study: <ul style="list-style-type: none"> <li>• <u>Emicizumab</u></li> <li>• <u>Fitusiran</u></li> <li>• <u>Concizumab</u></li> </ul>  | 11        |
| 9.4.8.1/Concomitant Hemophilia Treatments              | Subjects on prophylactic FVIII therapy will discontinue their regular treatment regimen starting 4 weeks <del>following</del> <u>after</u> the day of infusion or after FVIII activity has reached at least 5 IU/dL (whichever is earlier) and switch to an “on-demand” schedule. FVIII replacement therapy can always be taken as needed by the subject for treatment of an acute bleeding episode; the subject must carefully record his treatment and bleeding episodes in his diary. Prophylactic FVIII use can be used on a   | 17        |





| Section No./Title   | Revision   | Rationale |
|---|--|-----------|
|   | <p>case-by-case basis and in consultation with the Medical Monitor to prevent bleeding in extenuating circumstances (eg, peri-operative).</p> <p>In addition, information on FVIII usage and bleeding episodes by medical history must be well-documented and available and will be collected from subjects for the 12--month period immediately preceding study enrollment. Further information on the details that should be provided as part of the subject's well-documented medical and FVIII usage history are provided in the <del>Study Reference Manual</del> <u>On Site File Binder</u>.</p> |           |
| 9.4.8.2/Therapeutic Glucocorticoid Treatment of Elevated ALTs | Hepatitis B status and HCV viral load will be rechecked 6 weeks after the start of oral corticosteroid treatment and then 1 week and 13 weeks after the completion of oral corticosteroid treatment, <u>in subjects with a history of hepatitis B or hepatitis C.</u>  | 8         |
| 9.4.9/Treatment Compliance                                    | Study drug will be administered to subjects at the study site and/or the dosing facility by a qualified health care professional. The quantity dispensed, returned, used, lost, etc. must be recorded on <del>the</del> <u>the</u> dispensing log <del>provided for the study</del> . Sites will be instructed to return or destroy all used and unused study drug containers.   | 17        |
| 9.5/IP Accountability   | The Investigator or designee is responsible for maintaining accurate records (including dates and quantities) of IP(s) received and IP lost or accidentally or deliberately destroyed. The Investigator or designee must retain all unused or expired study supplies until the study monitor (on-site CRA) has confirmed the accountability data, <u>if allowed by local SOPs</u> .  | 17        |
| 9.5.1/Return and Disposal of Clinical Supplies                | <p>Unused study drug must be kept in a secure location for accountability and reconciliation by the study monitor. The Investigator or designee must provide an explanation for any destroyed or missing study drug or study materials, <u>(or must be referenced in their institution SOPs)</u>.</p> <p>...</p> <p>All study drug and related materials should be stored, inventoried, reconciled, and destroyed or returned according to applicable state and federal regulations and study procedures. For additional information, please refer to the <del>Study Pharmacy Manual</del>.</p>        | 17        |



| Section No./Title                          | Revision   | Rationale |
|--|--|-----------|
| 9.6/Dietary or Other Protocol Restrictions | <u>Subjects should be advised to abstain from any blood or sperm donation after BMN 270 infusion, until there is no further evidence of vector shedding.</u>   | 12        |
| 9.7.2.1/FVIII Activity                     | <p>The primary efficacy variable is change of the <del>median</del> <u>hFVIII activity, as measured by one-stage clotting assay, during Weeks 48-49-52 post-BMN 270 infusion from baseline using a validated assay. Each subject's hFVIII activity during Weeks 49-52 is defined as the median of the values obtained during this 4-week window. Values for FVIII activity will be excluded if obtained within 72 hours since the last infusion of exogenous FVIII protein concentrates.</u></p> <p><u>If a subject has used FVIII within 5x the known half life of the FVIII c administered), 72 hours of a measurement day, all efforts should be made to obtain FVIII activity measurements when a 72-hour interval without FVIII use is achieved; The 72-hour wash-out period is only intended for subjects who have achieved FVIII ≥ 5 IU/dL at 16 weeks after BMN 270 infusion and who have not resumed FVIII replacement therapy.</u></p>   | 1, 17     |
| 9.7.4.1/PROs                               | <p><del>Details regarding the Haemo-QoL-A assessment will be included in the Study Reference Manual.</del> <u>On Site File Binder.</u></p> <p><del>A sample copy of the EQ-5D-5L and additional information are provided in the Study Reference Manual.</del> <u>On Site File Binder.</u></p> <p><del>A sample copy of the HAL and additional information are provided in the Study Reference Manual.</del> <u>On Site File Binder.</u></p> <p><del>A sample copy of the WPAI+CIQ:HS and additional information are provided in the Study Reference Manual.</del> <u>On Site File Binder.</u></p> <p><u>The Patient Reported Outcomes, Burdens, and Experiences (PROBE) questionnaire is designed to investigate and directly probe patient perspectives on outcomes they deem relevant to their life and care. PROBE aims to develop a new global tool to enhance the direct patient-voice in health care decision-making (Chai-Adisaksopha 2017). A sample copy of the PROBE questionnaire and additional information are provided in the On Site File Binder.</u></p> | 9, 17     |
| 9.7.7/Exploratory Assessments              | <p>Blood samples will be collected from subjects at the time points indicated in Table 9.1.1, Table 9.1.2, Table 9.1.3, and Table 9.1.4 to evaluate biochemical, molecular, cellular, and genetic/genomic aspects relevant to hemophilia A, <u>coagulation, and/or AAV gene transfer, and to develop assays used for these evaluations. Subjects may choose to opt out of the exploratory genetic/genomic research being done to study or try to discover genes that are not yet known to be associated with hemophilia A-is optional.</u></p>   | 17        |



| Section No./Title                            | Revision   | Rationale |
|--|--|-----------|
| 9.7.8.2/Clinical Laboratory Assessments      | Refer to the <del>Study Reference Manual</del> <u>On Site File Binder</u> for instructions on obtaining and shipping samples.<br>...<br><u>In addition to scheduled clinical laboratory assessments, a fasting blood lipid panel (including triglycerides, total cholesterol, HDL cholesterol, and LDL cholesterol) will be assessed at the BMN 270 infusion visit.</u>  | 5, 17     |
| 9.7.8.3/Liver Function and Hepatitis Testing | Evidence of ongoing hepatitis B or hepatitis C infection is exclusionary. <del>Subjects who have cleared a Hepatitis B infection or are seronegative do not need to receive the Hepatitis B vaccination.</del> Subjects with evidence of prior exposure will be tested for hepatitis B and hepatitis C reactivation at Week 16.<br><br>Subjects <u>with a previous history of hepatitis B or hepatitis C</u> who receive therapeutic oral corticosteroids prior to Week 16 do not need to complete the Week 16 reactivation assessment; instead, they will be tested for hepatitis B and hepatitis C reactivation at the time points listed in Table 9.1.5.  | 8, 17     |
| 9.7.8.6/Vector Shedding                      | Samples may be fractionated prior to shedding analysis in order to better characterize the presence, structure, and location of vector DNA and/or vector capsid within each matrix. If needed, the fractionation <del>will</del> <u>may</u> be performed with samples collected specifically for shedding analysis (saliva, blood, semen, urine, <del>faeces</del> <u>feces</u> ).   | 17        |
| 10.5.1/Expedited Reporting Requirements      | IND safety reports will be submitted within 7 calendar days for <del>unexpected</del> fatal or life-threatening <del>unexpected</del> suspected adverse reactions (SUSARs) and within 15 calendar days for other non-life-threatening SUSARs.  | 17        |
| 12.2/Screening Visit                         | The following procedures will be performed during the Screening Period: <ul style="list-style-type: none"> <li>• Documentation of bleeding episodes and FVIII usage (by either subject or clinical information) for the previous 12 months <ul style="list-style-type: none"> <li>○ Further information on details to be included in documentation of previous bleeding episodes and FVIII usage, refer to the <del>Study Reference Manual</del> <u>On Site File Binder</u>.</li> </ul> </li> <li>• <del>Von Willebrand Factor Antigen (VWF:Ag)</del></li> <li>• Blood samples for Biomarker testing (including HLA genotyping, <u>and</u> FVIII genotyping status, <del>TNF-<math>\alpha</math></del> and <del>IL10a</del> <u>single nucleotide polymorphisms</u>)</li> </ul> | 4, 6, 17  |





| Section No./Title          | Revision   | Rationale |
|----------------------------|--|-----------|
| 12.3/Baseline Visit        | <p>The following procedures will be performed during the Baseline Period:</p> <ul style="list-style-type: none"> <li>• Samples for hFVIII Assays <ul style="list-style-type: none"> <li>○ hFVIII coagulation activity exploratory assay (<del>collected but not tested prior to enrollment</del>)</li> <li>○ hFVIII total antibody assay (<del>collected but not tested prior to enrollment</del>)</li> <li>○ hFVIII protein assay (<del>collected but not tested prior to enrollment</del>)</li> </ul> </li> <li>• <u>Von Willebrand Factor Antigen (VWF:Ag)</u></li> <li>• <u>Patient Reported Outcomes, Burdens, and Experiences (PROBE) questionnaire</u></li> </ul>                                 | 6, 9, 17  |
| 12.4/Day 1                 | <p>The following procedures will be performed during the BMN 270 Infusion Visit:</p> <ul style="list-style-type: none"> <li>• <u>Fasting lipid panel (blood triglycerides, total cholesterol, HDL cholesterol, and LDL cholesterol) (sample collected pre-infusion)</u></li> <li>• PCR of vector DNA in blood, saliva, urine, semen, and stools <ul style="list-style-type: none"> <li>○ Collection of samples for PCR testing should occur <del>at least</del> <u>between 2 and 24</u> hours after the BMN 270 infusion has been completed</li> </ul> </li> </ul>   | 5, 17     |
| 12.5.7/Weeks 4, 12, and 26 | <p>At Weeks 4, 12, and 26, the following procedure will be performed:</p> <ul style="list-style-type: none"> <li>• <u>PROBE</u></li> </ul>   | 9         |
| 12.5.13/Week 16            | <p>At Week 16, the following procedure will be performed:</p> <ul style="list-style-type: none"> <li>• <u>Test for Hepatitis B and Hepatitis C reactivation (only in subjects with evidence of prior exposure to hepatitis B and/or hepatitis C)</u> <ul style="list-style-type: none"> <li>○ <del>Subjects with evidence of prior exposure will be tested for hepatitis B and hepatitis C reactivation at Week 16.</del> Subjects who receive therapeutic oral corticosteroids prior to Week 16 do not need to complete the Week 16 reactivation assessment; instead, they will be tested for hepatitis B and hepatitis C reactivation at the time points listed in Table 9.1.5.</li> </ul> </li> </ul> | 8         |
| 12.6.8/Week 52             | <p>At Week 52, the following procedures will be performed:</p>   | 9         |



| Section No./Title                   | Revision   | Rationale |
|-------------------------------------|--|-----------|
|                                     | <ul style="list-style-type: none"> <li>• <u>PROBE</u></li> </ul>   |           |
| 12.7.1/Year 2 –<br>Every 4 Weeks    | <p><u>During Year 2, every 3 months (± 2 4 weeks). At these times, (+ 2 weeks, or as scheduled to align with visits for performing assessments to be done every 3 months [Section 12.7.3]), the following procedures will be <del>completed</del> performed:</u></p> <ul style="list-style-type: none"> <li>• <u>Liver Function Tests (refer to Table 9.7.8.3.1)</u> <ul style="list-style-type: none"> <li>○ <u>LFTs may be monitored more or less frequently (and in particular when ALT values are &gt;1.5x ULN) based on discussion between the Medical Monitor and the Investigator and review of subject data, but LFTs will be monitored at least twice weekly during periods when a subject's ALT is ≥ 3x ULN.</u></li> </ul> </li> <li>• <u>FVIII Assays</u> <ul style="list-style-type: none"> <li>○ <u>FVIII activity level (chromogenic FVIII assay)</u></li> <li>○ <u>FVIII activity level (one-stage clot FVIII assay)</u></li> <li>○ <u>FVIII coagulation activity exploratory assay</u></li> <li>○ <u>Bethesda assay (with Nijmegen modification) for FVIII inhibitor level</u></li> <li>○ <u>FVIII protein assay</u></li> </ul> </li> </ul> | 7, 17     |
| 12.7.2/Years 3-5 –<br>Every 6 Weeks | <p><u>During Years 3-5, every 6 weeks (± 2 weeks), the following procedures will be performed:</u></p> <ul style="list-style-type: none"> <li>• <u>Liver Function Tests (refer to Table 9.7.8.3.1)</u> <ul style="list-style-type: none"> <li>○ <u>LFTs may be monitored more or less frequently (and in particular when ALT values are &gt;1.5x ULN) based on discussion between the Medical Monitor and the Investigator and review of subject data, but LFTs will be monitored at least twice weekly during periods when a subject's ALT is ≥ 3x ULN.</u></li> </ul> </li> <li>• <u>FVIII Assays</u> <ul style="list-style-type: none"> <li>○ <u>FVIII activity level (chromogenic FVIII assay)</u></li> <li>○ <u>FVIII activity level (one-stage clot FVIII assay)</u></li> <li>○ <u>FVIII coagulation activity exploratory assay</u></li> <li>○ <u>Bethesda assay (with Nijmegen modification) for FVIII inhibitor level</u></li> </ul> </li> </ul>   | 7, 17     |



| Section No./Title                 | Revision  | Rationale |
|-----------------------------------|---|-----------|
|                                   | <ul style="list-style-type: none"> <li>▪ <u>If a subject tests positive in the Bethesda assay (with Nijmegen modification) during Years 3-5, a fresh sample should be collected within 4 weeks of the initial visit that had a positive result.</u></li> <li>○ <u>FVIII protein assay</u></li> </ul>  |           |
| 12.7.3/Every 3 Months (Years 2-5) | <p>Every 3 months (<math>\pm</math> 2 weeks), the following procedures will be performed:</p> <ul style="list-style-type: none"> <li>● <u>Liver Function Tests (refer to )</u> <ul style="list-style-type: none"> <li>○ <u>LFTs may be monitored more or less frequently (and in particular when ALT values are <math>&gt;1.5x</math> ULN) based on discussion between the Medical Monitor and the Investigator and review of subject data.</u></li> </ul> </li> <li>● <u>FVIII Assays</u> <ul style="list-style-type: none"> <li>○ <u>FVIII activity level (chromogenic FVIII assay)</u></li> <li>○ <u>FVIII activity level (one-stage clot FVIII assay)</u></li> <li>○ <u>FVIII coagulation activity exploratory assay</u></li> <li>○ <u>Bethesda assay (with Nijmegen modification) for FVIII inhibitor level</u></li> <li>○ <u>FVIII protein assay</u></li> </ul> </li> </ul> | 7, 17     |
| 12.7.5/Years 2-5 – Every 6 Months | <p>Every six months starting at the Week 78 visit (ie, 26 weeks after the Week 52 visit at the end of Year 1 of the Long-Term Follow-up period), the following <del>procedure</del><u>procedures</u> will be performed:</p> <ul style="list-style-type: none"> <li>● <u>PROBE</u></li> </ul>  | 9         |
| 12.8/ETV                          | <p>At the Early Termination visit, as many of the following assessments as possible should be done:</p> <ul style="list-style-type: none"> <li>● <u>PROBE</u></li> </ul>  | 9         |
| 14.1/Interim Analysis             | <p>An interim analysis is planned <del>when after all</del><u>at 20</u> treated subjects have completed the Week 26 visit, <del>(or have discontinued study participation prior to Week 26).</del></p> <p>The primary efficacy endpoint for the interim analysis is change in the <del>median hFVIII activity during Weeks 22-26 post-BMN 270 infusion from baseline.</del> The secondary efficacy endpoints for the interim analysis will be defined as follows: <u>hFVIII</u></p>   | 1, 2, 17  |



| Section No./Title | Revision  | Rationale |
|-------------------|---|-----------|
|                   | <p><u>activity, as measured by one-stage clotting assay, during Weeks 23-26 post-BMN 270 infusion from baseline. Each subject's hFVIII activity during Weeks 23-26 is defined as the median of the values obtained during this 4-week window. Values for hFVIII activity will be excluded if obtained within 72 hours since the last infusion of exogenous FVIII protein concentrates. A 2-sided one-sample t-test will be used to test the null hypothesis that the change is 0 or less against the alternative hypothesis that the change is greater than 0. In addition, subjects' hFVIII activity post-Week 23, defined as the median of the values obtained from Week 23 to the time of last follow-up, will be analyzed similarly as an important sensitivity analysis, utilizing additional data beyond Week 26. Descriptive summaries of the proportions of subjects whose FVIII activity during Weeks 23-26 and from Week 23 to the time of last follow-up is greater than or equal to select thresholds, such as 15, 25 and 30 IU/dL, and the confidence intervals of the proportions will be provided, respectively. The FVIII activity as measured by chromogenic assay will be analyzed similarly, as a supportive analysis.</u></p> <p><del>Change in the annualized utilization (IU/kg) of exogenous FVIII replacement therapy during Weeks 5-26 post-BMN 270 infusion from baseline.</del></p> <p><del>Change in the annualized number of bleeding episodes requiring exogenous FVIII replacement treatment during Weeks 5-26 post-BMN 270 infusion from baseline (tested first for non-inferiority using a margin of 3.5 and then for superiority).</del></p> <p><del>The primary and secondary efficacy hypotheses for the interim analysis will be tested sequentially according to the same order as described for the final analysis.</del></p> <p><del>The Bonferroni</del>The Hochberg procedure will be used to adjust for multiplicity using <del>alpha=0.001 at</del> of the interim analysis at <u>Week 26 and alpha=0.049 at</u> the final analysis.</p> <p><del>However,</del> <u>at Week 52 of the primary efficacy endpoint. (Regardless of the interim analysis results, the study will continue and the final analysis will be performed at Week 52.) At the final analysis at Week 52, the secondary efficacy endpoints will be tested hierarchically; the level of significance will be determined by the truncated Hochberg procedure for parallel gatekeeping. These multiple comparison procedures are described in greater detail in Section 14.2.</u></p> <p>The <u>secondary and tertiary endpoints will be analyzed summarized descriptively at the interim (Week 26) and final (Week 52) analyses, irrespective of the aforementioned hierarchical testing analysis.</u></p> |           |



| Section No./Title                             | Revision   | Rationale |
|---|--|-----------|
| 14.2/Primary and Secondary Efficacy Endpoints | <p>For the primary efficacy endpoint at Week 52 (ie, the change in the <del>median</del> hFVIII activity during Weeks 48-52 post-BMN 270 infusion from baseline, <u>as measured by one-stage clotting assay</u>), a one-sample t-test will be used to test the null hypothesis that the change is 0 or less against the alternative hypothesis that the change is greater than 0. <u>Descriptive summaries of the proportions of subjects whose FVIII activity during Weeks 49-52 is greater than or equal to select thresholds, such as 15, 25 and 30 IU/dL, and the confidence intervals of the proportions will also be provided. The FVIII activity as measured by chromogenic assay will be analyzed similarly, as a supportive analysis.</u></p> <p>...</p> <p>For the second secondary efficacy endpoint at Week 52 (ie, the change in <u>ABR, the annualized bleeding rate, number of bleeding episodes requiring exogenous FVIII replacement treatment</u> during Weeks 5-52 post-BMN 270 infusion from baseline), a one-sample t-test will be performed to test for non-inferiority of BMN 270 against FVIII prophylaxis (<u>ie, the baseline ABR calculated using subjects' historical medical records during the year prior to enrollment</u>) using a margin of 3.5, <u>i.e., to test the null hypothesis that the change is 3.5 or greater against the alternative hypothesis that the change is less than 3.5.</u> If non-inferiority is demonstrated, the test for superiority of BMN 270 against FVIII prophylaxis will be performed. <u>The primary analysis of this endpoint is planned to be performed pooling all 70 enrolled subjects, assuming the baseline ABR of the first enrolled 20 subjects (whose baseline data is entirely based on historical medical records) and the baseline ABR of the later enrolled 50 subjects (whose baseline data is based on both data from historical medical records and data collected during study BMN 270-902) are similar. The poolability will be examined by comparing the corresponding baseline ABRs. Details will be provided in the statistical analysis plan.</u></p> <p>The primary and secondary efficacy hypotheses will be tested <u>sequentially/hierarchically</u> according to the order described above. <u>Multiple comparison procedures are described in greater detail in the following.</u></p> <p><u>As described in Section 14.1.1, an interim analysis is planned when after all 4020 treated subjects have completed the Week 26 visit. The Bonferroni (or have discontinued study participation prior to Week 26).</u></p> <p><u>For controlling the probability of a Type I error for the interim and final analyses of the primary efficacy endpoint, the Hochberg procedure will be used to adjust for multiplicity using alpha=. That is, if both the interim and final p-values are <math>\leq 0.00105</math>, then both are declared statistically significant; otherwise, if either p-value is <math>\leq 0.025</math>, then that result is significant.</u></p> | 1, 2, 17  |



| Section No./Title | Revision  | Rationale |
|-------------------|---|-----------|
|                   | <p><del>(All p-values are 2-sided.) Since the final analysis results are not available at the time of the interim analysis and alpha=0.049 at the final analysis, the procedure will be implemented as follows.</del></p> <ul style="list-style-type: none"> <li>• <u>If <math>p \leq 0.025</math> at the interim analysis, then the interim result is declared significant and the final analysis is carried out at the 0.05 level.</u></li> <li>• <u>If <math>0.025 &lt; p \leq 0.05</math> at the interim analysis, then the final analysis is carried out at the 0.05 level. However, the significance of the interim result cannot be established at the time of the interim analysis; if <math>p \leq 0.05</math> for the final analysis, then both the interim and final analyses are declared significant, but if <math>p &gt; 0.05</math> for the final analysis, then neither the interim nor the final analysis is declared significant.</u></li> <li>• <u>If <math>p &gt; 0.05</math> at the interim analysis, then the interim analysis is not declared significant, and the final analysis is carried out at the 0.025 level.</u></li> </ul> <p>Regardless of the interim analysis results, the study will continue <u>to completion</u> and the final analysis will be performed at Week 52.</p> <p><u>For controlling the probability of a Type I error for the primary and secondary efficacy endpoints at the final analysis, a hierarchical (sequential) multiple comparison procedure will be used, after applying the truncated Hochberg procedure for parallel gatekeeping. Specifically:</u></p> <ul style="list-style-type: none"> <li>• <u>If both the interim and final results are significant (as described above), then at the final analysis the primary and secondary endpoints will be tested hierarchically using <math>\alpha = 0.05</math>.</u></li> <li>• <u>If either the interim or the final result, but not both, is significant, then at the final analysis the primary and secondary endpoints will be tested hierarchically using <math>\alpha = 0.025</math>.</u></li> </ul> <p><u>If neither the interim nor the final result is significant, then at the final analysis the secondary endpoints will not be tested.</u></p> <p><del>The tertiary endpoints will be analyzed at the interim (Week 26) and final (Week 52) analyses, irrespective of the aforementioned hierarchical testing.</del></p> |           |
| 14.6/Sample Size  | <p><del>Approximately 40</del><u>Seventy (70)</u> subjects may be dosed in the study. <del>Assuming a rate of subject discontinuation of up to 15%, a</del><br/> <u>The sample size for this study is based on clinical and statistical considerations in order to provide sufficient data to assess both safety and efficacy of 40</u><del>BMN 270.</del></p>  | 1, 17     |



| Section No./Title | Revision   | Rationale |
|-------------------|--|-----------|
|                   | <p><del>A sample size of 70 will provide at least 90% power to demonstrate that the change in median hFVIII activity at during Weeks 49-52 from baseline is statistically significant greater than 0, assuming an effect size of 0.6, using a one-sample t-test with a 2-sided significance level of 0.049. Similarly, the 0.25.</del></p> <p><del>A sample size of 40 will also have provide at least 90% power for hypothesis testing of the first secondary efficacy endpoint, i.e., to demonstrate that the change in the annualized FVIII-utilization (IU/kg) from of exogenous FVIII replacement therapy during Week 5 to Week 52 post-BMN 270 infusion from the baseline is less than 0, assuming an effect size of 0.6, using a one-sample t-test with a 2-sided significance level of 0.049.</del></p> <ul style="list-style-type: none"> <li><del>Regarding the second secondary endpoint, ie, the non-inferiority test for</del> A sample size of 70 will also have at least 95% power to demonstrate that the change in the annualized number of bleeding episodes requiring exogenous FVIII replacement treatment, in the pivotal studies (ABR) during Week 5 to Week 52 of recent approved FVIII replacement products, the estimated ABRs are consistent across different studies and products. The mean ABRs of prophylactic treatment groups range the study post-BMN 270 infusion from 3 to 6, approximately, and the mean ABRs of episodic treatment groups range from 30 to 60, approximately. The the baseline ABR is less than 3.5 (non-inferiority margin of 3.5 is chosen to preserve 90% of the efficacy of prophylactic over episodic treatment, justified by advantages of BMN 270 over FVIII replacement treatment. These advantages observed in the dose cohort 6E13 vg/kg in Study 270-201 include:</li> </ul> <p><del>Stable), assuming the pre- and durable FVIII activity levels protective against the majority of bleeds without FVIII trough levels</del></p> <p><del>Significant reduction in need for FVIII replacement therapies</del></p> <p><del>Improved quality of life</del></p> <p><del>Assuming the mean post-BMN 270 infusion population mean ABRs are 3.5 and standard deviation of the change in ABR from baseline are 0 and 6 bleeds per year, respectively, a sample size of 40 with a discontinuation rate of 15% will provide at least 90% power for testing non-inferiority using a margin of 3.5, using a one-sample t-test at with a 2-sided significance level of 0.049. Under the same assumptions, a sample size of 70 will have approximately 90% power to demonstrate that the change is less than 0, i.e. superiority of BMN 270 against FVIII prophylaxis.</del></p> |           |



| Section No./Title         | Revision   | Rationale |
|---------------------------|--|-----------|
|                           | <u>Overall, a sample size of 70 will have greater than 80% power for testing the primary and secondary efficacy endpoints hierarchically at the final analysis with a 2-sided significance level of 0.025.</u>   |           |
| 14.7/Analysis Populations | The efficacy analysis set will <del>be comprised</del> <u>consist</u> of all subjects who <del>have received</del> <u>receive</u> the BMN 270 infusion.<br>The safety population will <del>consist of all subjects who receive BMN 270 infusion during</del> <u>is the study</u> <del>same as the efficacy analysis set.</del>   | 17        |
| 15/DMC                    | The duties of the DMC will include: <ul style="list-style-type: none"> <li>• Recommending whether to enroll subjects at a <del>lower</del> <u>different</u> dose level (<u>not to exceed 6E13 vg/kg</u>) based on emerging data from 270-301 and the overall risk/benefit analysis of BMN 270.</li> </ul>  | 17        |
| 21/References             | <u>Chai-Adisaksopha C, Skinner M, Curtis R, et al. Psychometric Properties of the Patient Reported Outcomes, Burdens and Experiences (PROBE) Questionnaire. Blood. 2017;130:5645.</u><br><del>Pasi, J, Wong, W, Rangarajan, S, Wilde, J et al. Interim results of an open-label, phase 1/2 study of BMN 270, an AAV5-FVIII Gene Transfer in Severe Hemophilia A. Haemophilia 22[Suppl. 4], 151-152. 2016.</del><br><u>Pasi, KJ, Rangarajan, S, Kim, B, et al. Achievement of Normal Circulating Factor VIII Activity Following BMN 270 AAV5-FVIII Gene Transfer: Interim, Long-Term Efficacy and Safety Results from a Phase 1/2 Study in Patients with Severe Hemophilia A. Blood 130[Suppl. 1], 603. 2017.</u> | 9, 17     |



# B<sup>®</sup>OMARIN

## CLINICAL STUDY PROTOCOL

|   |   |
|---|---|
| <b>Study Title:</b>   | A Phase 3 Open-Label, Single-Arm Study To Evaluate The Efficacy and Safety of BMN 270, an Adeno-Associated Virus Vector-Mediated Gene Transfer of Human Factor VIII in Hemophilia A Patients with Residual FVIII Levels $\leq$ 1 IU/dL Receiving Prophylactic FVIII Infusions |
| <b>Protocol Number:</b>   | 270-301   |
| <b>Active Investigational Product:</b>  | AAV5-hFVIII-SQ  |
| <b>IND/European Union Drug Regulating Authorities Clinical Trials (EudraCT) Number:</b> | 2017-003215-19<br>IND #: 017659   |
| <b>Indication:</b>  | Hemophilia A  |
| <b>Sponsor:</b>   | BioMarin Pharmaceutical Inc.<br>105 Digital Drive<br>Novato, CA 94949   |
| <b>Development Phase:</b>   | Phase 3   |
| <b>Sponsor's Responsible Medical Monitor:</b>   | PI [REDACTED] MD, MPhil<br>PI [REDACTED]<br>BioMarin Pharmaceutical Inc.<br>105 Digital Drive<br>Novato, CA 94949   |
| <b>Duration of Subject Participation:</b>   | Approximately 264 weeks   |
| <b>Dose:</b>  | 6E13 vg/kg  |
| <b>Study Population:</b>  | Males aged 18 or older  |
| <b>Date of Original Protocol:</b>   | 14 August 2017  |
| <b>Date of Amendment 1 (United States Specific):</b>                                    | 2 October 2017  |
| <b>Date of Amendment 1 (Global)</b>   | 25 January 2018   |
| <b>Date of Amendment 2 (Germany-Specific)</b>   | 26 June 2018  |
| <b>Date of Amendment 2 (Global)</b>   | 28 June 2018  |

Property of BioMarin

**CONFIDENTIAL**

May not be divulged, published, or otherwise disclosed to others without prior written approval from BioMarin.

This study will be conducted according to the principles of Good Clinical Practice as described in the U.S. Code of Federal Regulations and the International Conference on Harmonisation Guidelines, including the archiving of essential documents



---

## CLINICAL STUDY PROTOCOL AMENDMENT SUMMARY

### Amendment 2

**Date: 28 June 2018**

---

### RATIONALE AND SUMMARY OF CHANGES

A summary of major changes covered by Amendment 2 to the 270-301 protocol is provided below:

1. The sample size of the study has been changed to 130, and the number of potential sites has been increased to 60.

**Rationale:** The sample size has been increased due to changes in the assumptions for sample size calculation. The calculation of baseline value for the primary analysis of annualized bleeding rate (ABR) changed from using one-year data before screening on all subjects to using approximately 6-month data collected from subjects enrolled in Study 270-902. This change resulted in an increase in the variance used for sample size collection and, hence, an increased sample size.

2. Details of the sample size calculation, missing data handling, and sensitivity analyses have been added.

**Rationale:** These details have been added for purposes of clarifying the planned statistical analyses to be performed for this study.

3. Language concerning the occurrence and management of infusion-related reactions has been added.

**Rationale:** Three subjects recently experienced medically important infusion-related reactions (all grade 2) associated with valoctocogene roxaparvovec administration that were reported as serious adverse events due to prolonged observation in the hospital. Two subjects were enrolled in 270-301, and one subject was enrolled in Study 270-203 (phase 1/2, open-label study in subjects with pre-existing AAV5 antibodies receiving the 6E13 vg/kg dose of BMN 270). All of these infusion-related reactions were effectively managed clinically and resolved without any clinical sequelae.

The initial infusion rate will be 1 mL/min, which should be increased every 30 minutes by 1 ml/min to a maximum of 4 mL/min, provided that the subject is asymptomatic and tolerates the infusion. Adjustment/interruption of the infusion rate and/or duration may be required in the event of an adverse reaction occurring during the infusion. If necessary, anti-histamine, anti-pyretic, and/or corticosteroid administration is permitted prior to restarting an infusion interrupted by an infusion-related reaction.



To better elucidate the mechanisms of infusion-related hypersensitivity reactions, additional plasma samples will be taken within 1 hour of onset of a suspected infusion-related reaction and again 8 to 24 hours following resolution of symptoms. Samples will be used to assess acute phase response reactants, complement activation, inflammatory biomarkers, and IgE.

4. Language in the inclusion criterion related to a subject's history of FVIII inhibitors has been clarified.

**Rationale:** The original language caused some issues of misinterpretation of Sponsor intent. The revised language removes the ambiguity.

5. Language regarding the HIV inclusion criterion has been modified.

**Rationale:** The original language was reported as being unclear and leading to misunderstanding of sponsor intent. The revised language clarifies the inclusion criterion.

6. Language has been added to permit use of mobile nursing (MN) services, provided that the site is able to implement them and the subject consents, for non every 3-month visits after Week 52.

**Rationale:** Allowing for mobile nursing services at the every 4 week (during Year 2) and every 6 week (during Years 3-5) visits will help alleviate subject travel burden.

7. Language has been added to include ABO testing.

**Rationale:** ABO blood group results will be collected at Baseline to potentially correlate with FVIII activity level results in an exploratory manner.

8. Clarified that, on the day of infusion, subjects are not required to be admitted to a hospital to receive the infusion (ie, the infusion may be conducted in any facility that has the requisite capabilities to prepare and perform the infusion, as well as monitor subjects for at least 8 hours).

**Rationale:** Inpatient admission is not required for the infusion and 8-hour post-infusion observation period.

9. Clarified that the requirement for contraception use can end as early as Week 12, in the case that a subject has had 3 consecutive negative semen vector shedding assessments prior to that time point.

**Rationale:** Language in the protocol that stated that all subjects must continue with contraception for at least 26 weeks after infusion was inconsistent with the statement that semen sampling could be stopped as early as Week 12 if a subject had had 3 consecutive negative assessments. Revised language makes it clear that all subjects must remain on contraception and provide semen samples for assessment through Week 12, but after that timepoint, both contraception and semen sample assessment can be discontinued once 3 consecutive negative results have been obtained.



10. Clarified that assessment of concomitant medications and adverse events should be performed at the every 4-week visits during Year 2, and at the every 6-week visits during Years 3-5.

**Rationale:** Previously, the protocol called for assessment of AEs and concomitant medications every 3 months during Years 2-5; however, assessment at each visit during Years 2-5 is more appropriate and does not significantly increase subject or site burden.

11. Clarified that vector shedding assessments, if required, can be performed at the every 6-week visits during Years 3-5.

**Rationale:** Previously, the protocol called for vector shedding assessments, if required, to be done every 4 weeks after Week 52 until clearance. During Years 3-5, when subjects are being assessed for FVIII and liver function every 6 weeks, an every 4-week schedule for vector shedding would add to subject burden. Obtaining results every 6 weeks is sufficient to monitor vector shedding for subject safety and also aligns these assessments with the FVIII and liver function assessment visits.

12. Added language that subjects will fast for at least 8 hours prior to collection of pre-infusion laboratory samples on the day of infusion.

**Rationale:** A fasting lipid panel is part of the infusion day laboratory assessment; as such, subjects need to fast for an adequate amount of time prior to the assessment to allow for accurate results.

13. Clarified that hepatitis B testing at Screening should include hepatitis B surface antigen (HBsAg), hepatitis B surface antibody (HBsAb), and hepatitis B core antibody (HBcAb) testing.

14. Added language clarifying that if the investigational product preparation, infusion, and post-infusion observation period require transfer to an inpatient setting for completion, in the absence of an adverse event (AE), this will not be considered a serious AE for safety reporting purposes.

15. The vector genome schematic figure has been updated.

16. Changes have been made to correct minor errors and for purposes of clarity and consistency.

Refer to Section [25](#) for a summary of revisions to Amendment 1 (dated 25 January 2018).



## 2 SYNOPSIS

|   |   |  |
|---|---|--|
| <p><b>NAME OF COMPANY</b><br/>BioMarin Pharmaceutical Inc.<br/>105 Digital Drive<br/>Novato, CA 94949</p> <p><b>NAME OF FINISHED PRODUCT:</b><br/>BMN 270</p> <p><b>NAME OF ACTIVE INGREDIENT:</b><br/>AAV5-hFVIII-SQ</p>   | <p><b>SUMMARY TABLE</b><br/>Referring to Part of the<br/>Dossier:</p> <p>Volume:</p> <p>Page:</p> <p>Reference:</p> | <p><b>FOR NATIONAL<br/>AUTHORITY USE<br/>ONLY:</b></p> |
| <p><b>TITLE OF STUDY:</b><br/>A Phase 3 Open-Label, Single-Arm Study To Evaluate The Efficacy and Safety of BMN 270, an Adeno-Associated Virus Vector-Mediated Gene Transfer of Human Factor VIII in Hemophilia A Patients with Residual FVIII Levels <math>\leq</math> 1 IU/dL Receiving Prophylactic FVIII Infusions</p>  |   |  |
| <p><b>PROTOCOL NUMBER:</b><br/>270-301</p>  |   |  |
| <p><b>STUDY SITES:</b><br/>Approximately 60 sites worldwide.</p>  |   |  |
| <p><b>PHASE OF DEVELOPMENT:</b><br/>Phase 3</p>   |   |  |
| <p><b>STUDY RATIONALE:</b><br/>Hemophilia A (HA) is an X-linked recessive bleeding disorder that affects approximately 1 in 5,000 males. It is caused by deficiency in the activity of coagulation factor VIII (FVIII), an essential cofactor in the intrinsic coagulation pathway. This disorder can be either inherited, due to a genetic aberrancy, or an acquired immunologic process, leading to insufficient quantities of FVIII or a dysfunctional FVIII, but all are characterized by a defective coagulation process. The clinical phenotype of HA patients generally correlates tightly with the level of residual expression. Severe HA is classified as FVIII activity less than 1% of wild-type (<math>&lt; 1</math> IU/dL), moderate disease comprises 1-5% of wild-type activity and the mild form is 5-40% activity. The clinical manifestations of severe HA are frequent spontaneous bleeding episodes, predominantly in joints and soft tissues, with a substantially increased risk of death from hemorrhage when the brain is involved. Subjects with moderate disease can exhibit manifestations similar to those seen in patients with severe HA, resulting in a comparable bleeding phenotype.</p> <p>Treatment of severe HA presently consists of intravenous injection of plasma-derived or recombinant human FVIII protein (rhFVIII) concentrates, both as prophylaxis 2-3 times per week, and at the time of a bleed, to prevent or control bleeding episodes, respectively. The half-life for FVIII (12 to 18 hours for most approved products) necessitates frequent infusions, and although a major advance in the treatment of HA, it remains common for severe HA patients to continue to have multiple bleeding events on prophylactic therapy (median ABR of 1-4 with prophylaxis treatment in a recently published retrospective observational study (Berntorp, 2017) and between 1-2 in 6 prospective FVIII interventional studies) and on-demand-only therapy (median ABR of 4.5-18 in a recently published retrospective study (Berntorp, 2017) and between 20-60 in</p> |   |  |





| <b>NAME OF COMPANY</b><br>BioMarin Pharmaceutical Inc.<br>105 Digital Drive<br>Novato, CA 94949<br><br><b>NAME OF FINISHED PRODUCT:</b><br>BMN 270<br><br><b>NAME OF ACTIVE INGREDIENT:</b><br>AAV5-hFVIII-SQ   | <b>SUMMARY TABLE</b><br>Referring to Part of the<br>Dossier:<br><br>Volume:<br><br>Page:<br><br>Reference: | <b>FOR NATIONAL<br/>           AUTHORITY USE<br/>           ONLY:</b> |
|---|--|---|
| <p>6 prospective FVIII interventional studies). The consequence of multiple bleeding events is the development of debilitating multiple-joint arthropathy and substantially increased risk of death. Chemical modification (eg, direct conjugation of polyethylene glycol (PEG) polymers) and bioengineering of FVIII (eg, FVIII-Fc fusion proteins) improve half-life by approximately 50%, and thus, show promise in reduced dosing and maintaining activity levels above a 1% trough for a greater proportion of the dosing interval. However, patients with severe HA who are treated with extended half-life FVIII remain dependent on multiple infusions to maintain critical levels of FVIII activity. There is therefore a strong unmet need for a fully preventive treatment of HA to give patients a FVIII level compatible with a normal and hemorrhage-free life.</p> <p>Gene therapy offers the potential of disease-modifying therapy by continuous endogenous production of active FVIII following a single intravenous infusion of a vector encoding the appropriate gene sequence for long-term episomal expression. Hemophilia A is well-suited for a gene replacement approach because clinical manifestations are attributable to the lack of a single gene product (FVIII) that circulates in minute amounts (200 ng/ml) in the plasma. Tightly regulated control of gene expression is not essential, and even modest increases in the level of FVIII (any increase of the plasma level by 2 ng/ml induces an increase in activity of 1%) can ameliorate the severe form of hemophilia A. Thus, relatively small changes in endogenous FVIII activity can result in clinically relevant improvements in disease phenotype. Finally, the circulating FVIII response to gene transduction can be assessed using validated quantitative rather than qualitative endpoints that are easily assayed using established laboratory techniques.</p> <p>Several different gene transfer strategies for FVIII replacement have been evaluated, but adeno-associated viral (AAV) vectors show the greatest promise. They have an excellent and well-defined safety profile, and can direct long-term transgene expression with tropism and promoter specificity for specific tissues, such as the liver (for serotypes 2, 5 and 8 among others). Indeed, an ongoing gene therapy clinical trial for a related disorder, hemophilia B, has established that stable (median follow-up of 3.2 years) expression of human factor IX (hFIX) at levels that are sufficient for conversion of their bleeding phenotype from severe to moderate or mild is achievable following a single peripheral vein infusion of AAV8-hFIX vector. Several participants in this trial have been able to discontinue factor prophylaxis without suffering spontaneous hemorrhages, even when they undertook activities that previously resulted in bleeding. Thus, gene therapy treatment has resulted in a substantial improvement in their quality of life (Nathwani, 2014).</p> <p>BMN 270 is an AAV5-based gene therapy vector that expresses the SQ form of hFVIII under the control of a hybrid human liver-specific promoter (Figure 1).</p> |  |   |

|   |  |   |
|---|--|---|
| <b>NAME OF COMPANY</b><br>BioMarin Pharmaceutical Inc.<br>105 Digital Drive<br>Novato, CA 94949<br><br><b>NAME OF FINISHED PRODUCT:</b><br>BMN 270<br><br><b>NAME OF ACTIVE INGREDIENT:</b><br>AAV5-hFVIII-SQ | <b>SUMMARY TABLE</b><br>Referring to Part of the<br>Dossier:<br><br>Volume:<br><br>Page:<br><br>Reference: | <b>FOR NATIONAL<br/>         AUTHORITY USE<br/>         ONLY:</b> |
|---|--|---|

**Figure 1. hFVIII-SQ Vector Genome Schematic**

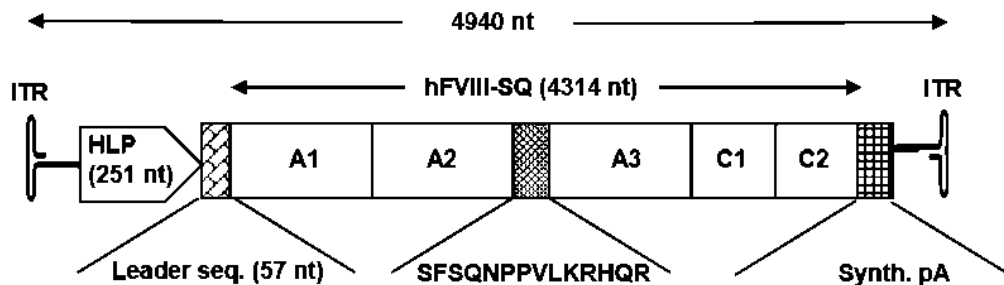

Legend –Note that schematic is not to scale; nt = nucleotides

BMN 270 will be delivered by a single intravenous dose and is designed to achieve stable, potentially life-long expression of active hFVIII in the plasma, synthesized from vector-transduced liver tissue.

BMN 270 is being evaluated in clinical study 270-201, an ongoing first-in-human, phase 1/2 dose escalation study in subjects with severe HA designed to assess the safety and efficacy of BMN 270 at various dose levels (6E12 vg/kg, 2E13 vg/kg, 4E13 vg/kg, 6E13 vg/kg). Specifically, 270-201 explores the relationship of vector dose to the augmentation of residual FVIII activity and whether these levels are sufficient to alter the clinical phenotype. Preliminary results from 270-201 have demonstrated that following gene transfer, FVIII activity above 15% (15 IU/dL) and, in many cases, within the normal range for FVIII, is achievable with a dose of 4-6E13 vg/kg with an acceptable safety profile (Pasi, 2017).

The current study is a Phase 3, single-arm, open-label study designed to assess whether, in an expanded sample, BMN 270 can safely alter the clinical phenotype of hemophilia A patients with residual FVIII activity  $\leq$  1 IU/dL.

**OBJECTIVES:**

The primary efficacy objective of the study is to:

- Assess the efficacy of BMN 270 defined as FVIII activity, as measured by one-stage clotting assay, during Weeks 49-52 following intravenous infusion of BMN 270

The secondary efficacy objectives of the study are to:

- Assess the impact of BMN 270 on usage of exogenous FVIII replacement therapy from Week 5 to Week 52



| <b>NAME OF COMPANY</b><br>BioMarin Pharmaceutical Inc.<br>105 Digital Drive<br>Novato, CA 94949<br><br><b>NAME OF FINISHED PRODUCT:</b><br>BMN 270<br><br><b>NAME OF ACTIVE INGREDIENT:</b><br>AAV5-hFVIII-SQ   | <b>SUMMARY TABLE</b><br>Referring to Part of the<br>Dossier:<br><br>Volume:<br><br>Page:<br><br>Reference: | <b>FOR NATIONAL<br/>           AUTHORITY USE<br/>           ONLY:</b> |
|---|--|---|
| <ul style="list-style-type: none"> <li>Assess the impact of BMN 270 on the number of bleeding episodes requiring exogenous FVIII replacement therapy from Week 5 to Week 52</li> </ul> <p>The tertiary efficacy objective of the study is to:</p> <ul style="list-style-type: none"> <li>Assess the impact of BMN 270 on patient-reported outcomes (PROs) at Week 52 of the study compared to baseline</li> </ul> <p>The safety objectives of the study are to:</p> <ul style="list-style-type: none"> <li>Evaluate the safety of BMN 270 during the first 52 weeks following intravenous infusion</li> <li>Assess the long-term safety of BMN 270</li> </ul>   |  |   |
| <p><b>STUDY DESIGN AND PLAN:</b></p> <p>This is a Phase 3, single-arm, open-label study in hemophilia A patients with residual FVIII levels <math>\leq 1</math> IU/dL treated continuously with prophylactic exogenous FVIII for a minimum of one year prior to enrollment. Subjects will be enrolled at approximately 60 sites worldwide. Subjects must have high-quality, well-documented historical data available concerning previous bleeding episodes and exogenous FVIII usage over the previous 12 months in order to be eligible to enroll in the study.</p> <p>Approximately 130 adult subjects with severe HA will receive a 6E13 vg/kg dose of BMN 270 as a single intravenous infusion. Approximately 20 subjects will enroll in the study with at least 12 months of well-documented high-quality historical data concerning previous bleeding episodes and exogenous FVIII usage, while approximately 110 subjects will enroll in the study after having completed approximately 6 months' participation in the BioMarin-sponsored non-interventional study 270-902.</p> |  |   |



|   |  |   |
|---|--|---|
| <b>NAME OF COMPANY</b><br>BioMarin Pharmaceutical Inc.<br>105 Digital Drive<br>Novato, CA 94949<br><br><b>NAME OF FINISHED PRODUCT:</b><br>BMN 270<br><br><b>NAME OF ACTIVE INGREDIENT:</b><br>AAV5-hFVIII-SQ | <b>SUMMARY TABLE</b><br>Referring to Part of the<br>Dossier:<br><br>Volume:<br><br>Page:<br><br>Reference: | <b>FOR NATIONAL<br/>         AUTHORITY USE<br/>         ONLY:</b> |
|---|--|---|

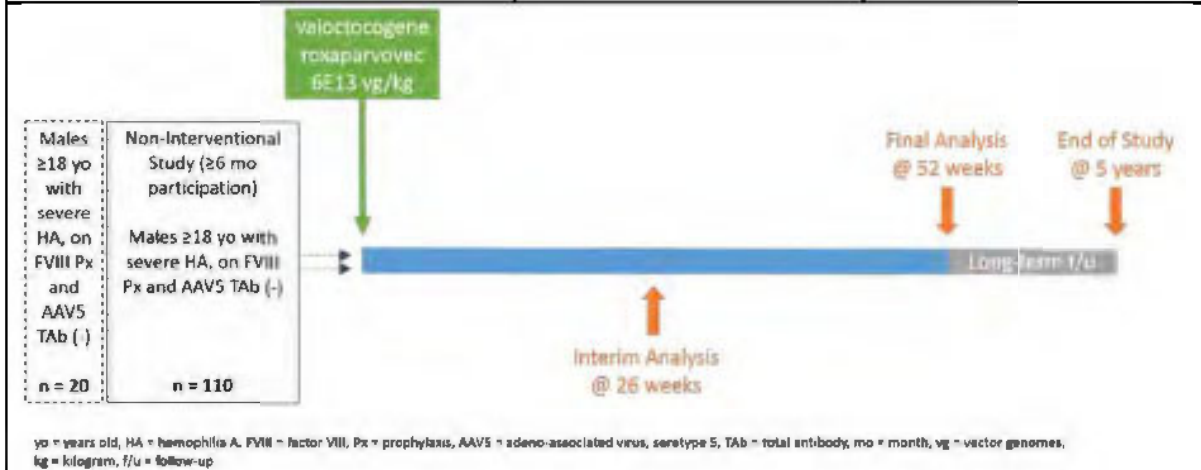

The Data Monitoring Committee (DMC) will review available safety and efficacy (eg, FVIII activity) data during the study on an ongoing basis and may determine, based on emerging data and the risk/benefit profile, that further enrollment at 6E13 vg/kg should be discontinued in favor of a different dose of BMN 270, not to exceed 6E13 vg/kg. If the DMC recommends a dosing modification, then additional subjects may be enrolled, up to a total of approximately 130 subjects, at the new BMN 270 dose level (regardless of the number of subjects previously enrolled at 6E13 vg/kg).

An interim analysis is planned after 20 treated subjects have completed the Week 26 visit.

The final analysis for the study will be performed after all subjects have been followed for 52 weeks post-BMN 270 infusion. After the final analysis, safety and efficacy will then continue to be assessed long-term in all subjects for a total of approximately 5 years.

To avoid breakthrough bleeding, subjects will only discontinue exogenous prophylactic FVIII replacement therapy after FVIII activity has reached at least 5 IU/dL or 4 weeks following infusion of BMN 270, whichever is earlier. Four weeks represents the time by which endogenous production of FVIII following gene transfer is expected to be efficacious.

Throughout the study, subjects with FVIII activity below 5 IU/dL may be monitored more frequently at the discretion of the Medical Monitor and the Investigator. In subjects who show an initial response to BMN 270 but who later have FVIII activity decline to  $< 5$  IU/dL, the investigator and Medical Monitor will review the subject's FVIII activity level trends (not specific FVIII activity levels) and discuss whether to resume prior FVIII prophylaxis. In addition, the



| <b>NAME OF COMPANY</b><br>BioMarin Pharmaceutical Inc.<br>105 Digital Drive<br>Novato, CA 94949<br><br><b>NAME OF FINISHED PRODUCT:</b><br>BMN 270<br><br><b>NAME OF ACTIVE INGREDIENT:</b><br>AAV5-hFVIII-SQ   | <b>SUMMARY TABLE</b><br>Referring to Part of the<br>Dossier:<br><br>Volume:<br><br>Page:<br><br>Reference: | <b>FOR NATIONAL<br/>           AUTHORITY USE<br/>           ONLY:</b> |
|---|--|---|
| <p>investigator will notify the subject of his FVIII activity levels and will discuss with the subject the risk of bleeding and when (and if) prior FVIII prophylaxis will be resumed.</p> <p>There will be an ongoing review of individual subject safety by the Medical Monitor, and both safety and efficacy data by the DMC. FVIII activity by a validated assay will be used to evaluate efficacy over the course of the study. Therapeutic oral corticosteroids may be initiated when a subject's ALT values are elevated or based on review of FVIII activity and liver enzyme data, and subsequent dosage adjustments made, after consultation between the Investigator and the Medical Monitor.</p> <p>Any safety signal may trigger a review of the data and possible additional immunogenicity studies or other diagnostics deemed necessary that include an assessment of cellular immune responses using collected peripheral blood mononuclear cells (PBMCs).</p>   |  |   |
| <p><b>NUMBER OF SUBJECTS PLANNED:</b><br/>           Approximately 130 subjects may enroll into the study.</p>  |  |   |
| <p><b>DIAGNOSIS AND ALL CRITERIA FOR INCLUSION AND EXCLUSION:</b><br/>           Patients are eligible to be included in the study only if all of the following criteria apply:</p> <ol style="list-style-type: none"> <li>1. Males <math>\geq</math> 18 years of age with hemophilia A and residual FVIII levels <math>\leq</math> 1 IU/dL as evidenced by medical history, at the time of signing the informed consent.</li> <li>2. Must have been on prophylactic FVIII replacement therapy for at least 12 months prior to study entry. High-quality, well-documented historical data concerning bleeding episodes and FVIII usage over the previous 12 months must be available.</li> <li>3. Treated/exposed to FVIII concentrates or cryoprecipitate for a minimum of 150 exposure days (EDs).</li> <li>4. Willing and able to provide written, signed informed consent after the nature of the study has been explained and prior to any study-related procedures.</li> <li>5. No previous documented history of a detectable FVIII inhibitor, and results from a Bethesda assay or Bethesda assay with Nijmegen modification of less than 0.6 Bethesda Units (BU) (or less than 1.0 BU for laboratories with a historical lower sensitivity cutoff for inhibitor detection of 1.0 BU) on 2 consecutive occasions at least one week apart within the past 12 months (at least one of which should be tested at the central laboratory).</li> </ol> |  |   |



| <b>NAME OF COMPANY</b><br>BioMarin Pharmaceutical Inc.<br>105 Digital Drive<br>Novato, CA 94949<br><br><b>NAME OF FINISHED PRODUCT:</b><br>BMN 270<br><br><b>NAME OF ACTIVE INGREDIENT:</b><br>AAV5-hFVIII-SQ   | <b>SUMMARY TABLE</b><br>Referring to Part of the<br>Dossier:<br><br>Volume:<br><br>Page:<br><br>Reference: | <b>FOR NATIONAL<br/>           AUTHORITY USE<br/>           ONLY:</b> |
|---|--|---|
| <p>6. Sexually active participants must agree to use an acceptable method of effective contraception, either double-barrier contraception (ie, condom + diaphragm; or condom or diaphragm + spermicidal gel or foam) or their female partner either using hormonal contraceptives or having an intrauterine device. Participants must agree to contraception use for at least 12 weeks post-infusion; after 12 weeks, subjects may stop contraception use only if they have had 3 consecutive semen samples with no detectable viral vector DNA.</p> <p>7. Willing to abstain from alcohol consumption for at least the first 52 weeks following BMN 270 infusion.</p> <p>8. HIV positive patients may be enrolled, only if the patient has a CD4 count &gt; 200/mm<sup>3</sup> and an undetectable viral load (unquantifiable viral load as defined as less than the limit of quantification by the testing laboratory's assay is permitted)</p> <p>Patients are excluded from the study if any of the following criteria apply:</p> <ol style="list-style-type: none"> <li>1. Detectable pre-existing antibodies to the AAV5 capsid.</li> <li>2. Any evidence of active infection or any immunosuppressive disorder, except for HIV infection as described in the inclusion criterion above.</li> <li>3. Significant liver dysfunction with any of the following abnormal laboratory results:               <ul style="list-style-type: none"> <li>• ALT (alanine transaminase) or AST &gt;2X ULN;</li> <li>• Total bilirubin &gt;2X ULN;</li> <li>• Alkaline phosphatase &gt;2X ULN; or</li> <li>• INR (international normalized ratio) ≥ 1.4.</li> </ul> </li> </ol> <p>Subjects whose liver laboratory assessments fall outside of these ranges may undergo repeat testing and, if eligibility criteria are met on retest, may be enrolled after confirmation by the Medical Monitor. In addition, subjects with abnormal laboratory results related to confirmed benign liver conditions are considered eligible for the study notwithstanding their abnormal laboratory results and may be enrolled after discussion with the Medical Monitor.</p> |  |   |



| <b>NAME OF COMPANY</b><br>BioMarin Pharmaceutical Inc.<br>105 Digital Drive<br>Novato, CA 94949<br><br><b>NAME OF FINISHED PRODUCT:</b><br>BMN 270<br><br><b>NAME OF ACTIVE INGREDIENT:</b><br>AAV5-hFVIII-SQ   | <b>SUMMARY TABLE</b><br>Referring to Part of the<br>Dossier:<br><br>Volume:<br><br>Page:<br><br>Reference: | <b>FOR NATIONAL<br/>           AUTHORITY USE<br/>           ONLY:</b> |
|---|--|---|
| <ul style="list-style-type: none"> <li>• Benign liver conditions are those conditions (eg, Gilbert’s syndrome) where physiologic hepatic findings can be considered non-serious in nature and do not confer illness or in most instances require treatment. Individuals with such conditions that do not impact laboratory values such as serum transaminases or conjugated bilirubin (eg, Gilbert’s syndrome) and enable assessment of potential liver toxicity following BMN 270 infusion may be included in the study following a review by the Medical Monitor.</li> </ul> <ol style="list-style-type: none"> <li>4. Prior liver biopsy showing significant fibrosis of 3 or 4 as rated on a scale of 0-4 on the Batts-Ludwig (Batts, 1995) or METAVIR (Bedossa, 1996) scoring systems, or an equivalent grade of fibrosis if an alternative scale is used.</li> <li>5. Evidence of any bleeding disorder not related to hemophilia A.</li> <li>6. Platelet count of &lt; 100 x 10<sup>9</sup>/L.</li> <li>7. Creatinine ≥ 1.5 mg/dL.</li> <li>8. Liver cirrhosis of any etiology as assessed by liver ultrasound.</li> <li>9. Chronic or active hepatitis B as evidenced by positive serology testing (hepatitis B surface antigen [HBsAg], hepatitis B surface antibody [HBsAb], and hepatitis B core antibody [HBcAb]) and confirmatory HBV DNA testing. Refer to the Centers for Disease Control (CDC) table for the interpretation of serological test results in the Laboratory Manual.</li> <li>10. Active Hepatitis C as evidenced by detectable HCV RNA or currently on antiviral therapy.</li> <li>11. Active malignancy, except non-melanoma skin cancer.</li> <li>12. History of hepatic malignancy.</li> <li>13. History of arterial or venous thromboembolic events (eg, deep vein thrombosis, non-hemorrhagic stroke, pulmonary embolism, myocardial infarction, arterial embolus), with the exception of catheter-associated thrombosis for which anti-thrombotic treatment is not currently ongoing.</li> <li>14. Known inherited or acquired thrombophilia, including conditions associated with increased thromboembolic risk, such as atrial fibrillation.</li> </ol> |  |   |



| <b>NAME OF COMPANY</b><br>BioMarin Pharmaceutical Inc.<br>105 Digital Drive<br>Novato, CA 94949<br><br><b>NAME OF FINISHED PRODUCT:</b><br>BMN 270<br><br><b>NAME OF ACTIVE INGREDIENT:</b><br>AAV5-hFVIII-SQ   | <b>SUMMARY TABLE</b><br>Referring to Part of the<br>Dossier:<br><br>Volume:<br><br>Page:<br><br>Reference: | <b>FOR NATIONAL<br/>           AUTHORITY USE<br/>           ONLY:</b> |
|---|--|---|
| <p>15. Treatment with any investigational product within 30 days or 5 half-lives of the investigational product prior to the screening period. For subjects who have received a prior investigational product, all ongoing adverse events (AEs) experienced while receiving that investigational product must have resolved prior to screening for this study.</p> <p>16. Any condition that, in the opinion of the Investigator or Sponsor would prevent the patient from fully complying with the requirements of the study (including possible corticosteroid treatment outlined in the protocol) and/or would impact or interfere with evaluation and interpretation of subject safety or efficacy result.</p> <p>17. Prior treatment with any vector or gene transfer agent.</p> <p>18. Major surgery planned in the 52-week period following the infusion with BMN 270.</p> <p>19. Use of systemic immunosuppressive agents, not including corticosteroids, or live vaccines within 30 days before the BMN 270 infusion.</p> <p>20. Concurrent enrollment in another clinical study, unless it is an observational (non-interventional) clinical study that does not interfere with the requirements of the current protocol or have the potential to impact the evaluation of efficacy and safety of BMN 270 and with prior consultation with the Medical Monitor.</p> <p>21. Known allergy or hypersensitivity to BMN 270 investigational product formulation.</p> <p>22. Unwilling to receive blood or blood products for treatment of an adverse event and/or a bleeding episode.</p> |  |   |
| <b>INVESTIGATIONAL PRODUCT(S), DOSE, ROUTE AND REGIMEN:</b><br>Each subject will receive a single intravenous infusion of BMN 270 at 6E13 vg/kg. The volume of infusion will depend on the subject's weight.  |  |   |
| <b>REFERENCE THERAPY(IES), DOSE, ROUTE AND REGIMEN:</b><br>No reference therapy will be evaluated in this study.  |  |   |
| <b>DURATION OF TREATMENT:</b><br>BMN 270 is given as a single dose by intravenous infusion.   |  |   |
| <b>CRITERIA FOR EVALUATION:</b><br><u>Efficacy:</u><br>Primary efficacy endpoint: <ul style="list-style-type: none"> <li>• Change of the hFVIII activity, as measured by one-stage clotting assay, during Weeks 49-52 post-BMN 270 infusion from baseline. Each subject's hFVIII activity during</li> </ul>   |  |   |



| <b>NAME OF COMPANY</b><br>BioMarin Pharmaceutical Inc.<br>105 Digital Drive<br>Novato, CA 94949<br><br><b>NAME OF FINISHED PRODUCT:</b><br>BMN 270<br><br><b>NAME OF ACTIVE INGREDIENT:</b><br>AAV5-hFVIII-SQ   | <b>SUMMARY TABLE</b><br>Referring to Part of the<br>Dossier:<br><br>Volume:<br><br>Page:<br><br>Reference: | <b>FOR NATIONAL<br/>           AUTHORITY USE<br/>           ONLY:</b> |
|---|--|---|
| <p>Weeks 49-52 is defined as the median of the values obtained during this 4-week window. Values for hFVIII activity will be excluded if obtained within 72 hours since the last infusion of exogenous FVIII protein concentrates.</p> <p>Secondary efficacy endpoints:</p> <ul style="list-style-type: none"> <li>• Change in the annualized utilization (IU/kg) of exogenous FVIII replacement therapy during Week 5 to Week 52 post-BMN 270 infusion from the baseline utilization of exogenous FVIII replacement therapy.</li> <li>• Change in the annualized number of bleeding episodes requiring exogenous FVIII replacement treatment (annualized bleeding rate, ABR) during Week 5 to Week 52 of the study post-BMN 270 infusion from the baseline ABR.</li> </ul> <p>Tertiary efficacy endpoints:</p> <ul style="list-style-type: none"> <li>• Change from baseline in the total score of HAEMO-QoL-A at Week 52 of the study post-BMN 270 infusion.</li> <li>• Change from baseline in the EQ-5D-5L score at Week 52 of the study post-BMN 270 infusion.</li> <li>• Change from baseline in the Haemophilia Activities List (HAL) score at Week 52 of the study post-BMN 270 infusion.</li> <li>• Change from baseline in the Work Productivity and Activity Impairment plus Classroom Impairment Questions: Hemophilia Specific (WPAI+CIQ:HS) score at Week 52 of the study post-BMN 270 infusion.</li> <li>• Change from baseline in Patient Reported Outcomes, Burdens, and Experiences (PROBE) score at Week 52 of the study post-BMN 270 infusion.</li> </ul> <p><u>Safety:</u></p> <p>The following safety outcome measurements will be assessed:</p> <ul style="list-style-type: none"> <li>• Incidence of adverse events (AEs) and serious AEs (SAEs)</li> <li>• Change in clinical laboratory tests (serum chemistry and hematology)</li> <li>• Change in vital signs</li> <li>• Change in physical examination</li> <li>• Vector shedding (blood, urine, semen, feces, saliva)</li> <li>• Liver function tests (LFTs, including ALT, AST, GGT, LDH, bilirubin, alkaline phosphatase)</li> <li>• Immune response to FVIII transgene product and AAV5 capsid proteins</li> </ul> |  |   |





| <b>NAME OF COMPANY</b><br>BioMarin Pharmaceutical Inc.<br>105 Digital Drive<br>Novato, CA 94949<br><br><b>NAME OF FINISHED PRODUCT:</b><br>BMN 270<br><br><b>NAME OF ACTIVE INGREDIENT:</b><br>AAV5-hFVIII-SQ  | <b>SUMMARY TABLE</b><br>Referring to Part of the<br>Dossier:<br><br>Volume:<br><br>Page:<br><br>Reference: | <b>FOR NATIONAL<br/>           AUTHORITY USE<br/>           ONLY:</b> |
|--|--|---|
| <p>Each subject will have comprehensive surveillance monitoring of LFTs (once per week for Weeks 1-36, and then once every 2 weeks from Weeks 37-52) during Year 1. LFTs will be monitored every four weeks during Year 2 and then every 6 weeks during Years 3-5 post-dose in the safety extension; the frequency and duration of LFT testing may be changed based on discussion between the Medical Monitor and the Investigator, review of subject data, and/or by independent DMC feedback.</p> <p>There will be a detailed assessment of cellular and humoral responses to AAV5 capsid and FVIII protein.</p> <p><u>Pharmacodynamics:</u></p> <p>The FVIII protein concentration and activity level as measured by a validated immunoassay and a validated FVIII activity assay, respectively, will be used for plasma profiles; FVIII protein and activity will be used to determine PD parameters.</p>  |  |   |
| <p><b>STATISTICAL METHODS:</b></p> <p><u>Sample Size</u></p> <p>One hundred and thirty (130) subjects may be dosed in the study. The sample size for this study is based on clinical and statistical considerations in order to provide sufficient data to assess both safety and efficacy of BMN 270.</p> <p>For the primary endpoint, a sample size of 130 will provide at least 95% power to demonstrate that the change in hFVIII activity during Weeks 49-52 from baseline is greater than 0, assuming an effect size of 0.6, using a one-sample t-test with a 2-sided significance level of 0.05.</p> <p>For the secondary endpoints, the analyses will be performed utilizing exogenous FVIII use and bleeding episode data from the 110 subjects whose baseline data will be prospectively collected for approximately 6 months in the non-interventional study 270-902, prior to their enrollment in 270-301. An analytic sample size of 110 will provide at least 95% power to demonstrate that the change in the annualized utilization (IU/kg) of exogenous FVIII replacement therapy during Week 5 to Week 52 post-BMN 270 infusion from baseline is less than 0, assuming an effect size of 0.6, using a one-sample t-test with a 2-sided significance level of 0.05.</p> <p>An analytic sample size of 110 will also have at least 95% power to demonstrate that the change in the annualized number of bleeding episodes requiring exogenous FVIII replacement treatment (ABR) during Week 5 to Week 52 of the study post-BMN 270 infusion from the baseline ABR is less than 3.5 (non-inferiority margin), assuming the pre- and post-BMN 270 infusion population mean ABRs are 3.5 and 1 respectively, using a one-sample t-test with a 2-sided significance level</p> |  |   |



| <b>NAME OF COMPANY</b><br>BioMarin Pharmaceutical Inc.<br>105 Digital Drive<br>Novato, CA 94949<br><br><b>NAME OF FINISHED PRODUCT:</b><br>BMN 270<br><br><b>NAME OF ACTIVE INGREDIENT:</b><br>AAV5-hFVIII-SQ  | <b>SUMMARY TABLE</b><br>Referring to Part of the<br>Dossier:<br><br>Volume:<br><br>Page:<br><br>Reference: | <b>FOR NATIONAL<br/>           AUTHORITY USE<br/>           ONLY:</b> |
|--|--|---|
| <p>of 0.05. Under the same assumptions, a sample size of 110 will have approximately 90% power to demonstrate that the change is less than 0, i.e. superiority of BMN 270 against FVIII prophylaxis.</p> <p>Overall, the planned sample size will have greater than 80% power for testing the primary and secondary efficacy endpoints hierarchically with a 2-sided significance level of 0.05.</p> <p><u>Analysis Population</u></p> <p>The efficacy analysis set will consist of all subjects who receive BMN 270 infusion.<br/>           The safety population is the same as the efficacy analysis set.</p> <p><u>Analysis</u></p> <p>For the primary efficacy endpoint at Week 52 (ie, the change in the hFVIII activity during Weeks 49-52 post-BMN 270 infusion from baseline, as measured by one-stage clotting assay), a one-sample t-test will be used to test the null hypothesis that the change is 0 or less against the alternative hypothesis that the change is greater than 0. Descriptive summaries of the proportions of subjects whose FVIII activity during Weeks 49-52 is greater than or equal to select thresholds, such as 15, 25 and 30 IU/dL, and the confidence intervals of the proportions will also be provided. The FVIII activity as measured by chromogenic assay will be analyzed similarly, as a supportive analysis. The analyses for the primary endpoint will be performed using the efficacy analysis set.</p> <p>For the secondary endpoints, the analyses will be performed on 110 subjects in the efficacy analysis set whose baseline data will be prospectively collected for approximately 6 months in the non-interventional study 270-902 prior to their enrollment in 270-301.</p> <p>For the first secondary efficacy endpoint at Week 52 (ie, the change in the annualized utilization (IU/kg) of exogenous FVIII replacement therapy during Weeks 5-52 post-BMN 270 infusion from baseline), a one-sample t-test will be performed to test the null hypothesis that the change is 0 or greater against the alternative hypothesis that the change is less than 0.</p> <p>For the second secondary efficacy endpoint at Week 52 (ie, the change in the annualized number of bleeding episodes requiring exogenous FVIII replacement treatment during Weeks 5-52 post-BMN 270 infusion from baseline), a one-sample t-test will be performed to test for non-inferiority of BMN 270 against FVIII prophylaxis (ie, the baseline ABR calculated using subjects' data collected in 270-902) using a margin of 3.5, ie, to test the null hypothesis that the change is 3.5 or greater against the alternative hypothesis that the change is less than 3.5. If non-inferiority is demonstrated, the test for superiority of BMN 270 against FVIII prophylaxis will be performed.</p> <p>The primary efficacy endpoint and secondary efficacy endpoints will be tested hierarchically according to the order described above.</p> |  |   |





| <b>NAME OF COMPANY</b><br>BioMarin Pharmaceutical Inc.<br>105 Digital Drive<br>Novato, CA 94949<br><br><b>NAME OF FINISHED PRODUCT:</b><br>BMN 270<br><br><b>NAME OF ACTIVE INGREDIENT:</b><br>AAV5-hFVIII-SQ   | <b>SUMMARY TABLE</b><br>Referring to Part of the<br>Dossier:<br><br>Volume:<br><br>Page:<br><br>Reference: | <b>FOR NATIONAL<br/>           AUTHORITY USE<br/>           ONLY:</b> |
|---|--|---|
| <p>An interim analysis is planned after 20 treated subjects have completed the Week 26 visit (or have discontinued study participation prior to Week 26). The primary efficacy endpoint for the interim analysis is change in the hFVIII activity, as measured by one-stage clotting assay, during Weeks 23-26 post-BMN 270 infusion from baseline. Each subject's hFVIII activity during Weeks 23-26 is defined as the median of the values obtained during this 4-week window. A 2-sided one-sample t-test will be used to test the null hypothesis that the change is 0 or less against the alternative hypothesis that the change is greater than 0. In addition, subjects' hFVIII activity post-Week 23, defined as the median of the values obtained from Week 23 to the time of last follow-up, will be analyzed similarly as an important sensitivity analysis, utilizing additional data beyond Week 26. Descriptive summaries of the proportions of subjects whose FVIII activity during Weeks 23-26 and from Week 23 to the time of last follow-up is greater than or equal to select thresholds, such as 15, 25 and 30 IU/dL, and the confidence intervals of the proportions will be provided, respectively. The FVIII activity as measured by chromogenic assay will be analyzed similarly, as a supportive analysis.</p> <p>The fallback procedure will be used to adjust for multiplicity of the interim analysis at Week 26 and the final analysis at Week 52 of the primary efficacy endpoint. (Regardless of the interim analysis results, the study is planned to continue upon the DMC's recommendation, and the final analysis will be performed at Week 52.) At the final analysis at Week 52, the secondary efficacy endpoints will be tested hierarchically.</p> <p>The secondary efficacy endpoints at the interim analysis (Week 26) will be summarized descriptively.</p> <p>The tertiary endpoints will be analyzed at the interim (Week 26) and final (Week 52) analyses, irrespective of the aforementioned hierarchical testing.</p> <p>Analysis of safety endpoints will be primarily descriptive. The incidence of AEs will be summarized by system organ class, preferred term, relationship to study drug, seriousness, and severity. Clinical laboratory test values, vital signs, vector shedding and immune response parameters will be summarized descriptively by visit.</p> |  |   |



### 3 TABLE OF CONTENTS

|       |  |    |
|-------|--|----|
| 2     | SYNOPSIS.....  | 5  |
| 3     | TABLE OF CONTENTS.....   | 18 |
| 4     | LIST OF ABBREVIATIONS AND DEFINITIONS OF TERMS.....                | 23 |
| 5     | ETHICS.....  | 26 |
| 5.1   | Institutional Review Board or Independent Ethics Committee .....   | 26 |
| 5.2   | Ethical Conduct of Study .....                                     | 26 |
| 5.3   | Subject Information and Informed Consent.....                      | 27 |
| 6     | INVESTIGATORS AND STUDY ADMINISTRATIVE STRUCTURE .....             | 28 |
| 7     | INTRODUCTION .....   | 29 |
| 7.1   | Nonclinical Studies .....  | 29 |
| 7.2   | Previous Clinical Studies .....                                    | 30 |
| 7.3   | Study Rationale .....  | 30 |
| 7.4   | Summary of Overall Risks and Benefits.....                         | 33 |
| 8     | STUDY OBJECTIVES.....  | 35 |
| 9     | INVESTIGATIONAL PLAN.....  | 36 |
| 9.1   | Overall Study Design and Plan .....                                | 36 |
| 9.2   | Discussion of Study Design, Including Choice of Control Group..... | 51 |
| 9.3   | Selection of Study Population.....                                 | 51 |
| 9.3.1 | Inclusion Criteria .....   | 51 |
| 9.3.2 | Exclusion Criteria.....  | 52 |
| 9.3.3 | Removal of Subjects from Treatment or Assessment .....             | 54 |
| 9.3.4 | Subject Identification and Replacement of Subjects.....            | 56 |
| 9.3.5 | Duration of Subject Participation.....                             | 56 |
| 9.4   | Treatments.....  | 56 |
| 9.4.1 | Treatments Administered .....                                      | 56 |
| 9.4.2 | Identity of Investigational Product.....                           | 56 |
| 9.4.3 | Storage.....   | 57 |
| 9.4.4 | Directions for Administration .....                                | 57 |
| 9.4.5 | Method of Assigning Subjects to Treatment Groups .....             | 58 |



|        |   |    |
|--------|---|----|
| 9.4.6  | Selection of Dose Used in the Study .....   | 59 |
| 9.4.7  | Blinding .....  | 59 |
| 9.4.8  | Prior and Concomitant Medications .....   | 59 |
| 9.4.9  | Treatment Compliance .....  | 63 |
| 9.5    | Investigational Product Accountability .....  | 63 |
| 9.5.1  | Return and Disposition of Clinical Supplies .....   | 63 |
| 9.6    | Dietary or Other Protocol Restrictions.....   | 64 |
| 9.7    | Safety and Efficacy Variables.....  | 64 |
| 9.7.1  | Safety and Efficacy Measurements Assessed .....   | 64 |
| 9.7.2  | Primary Efficacy Variables .....  | 64 |
| 9.7.3  | Secondary Efficacy Variables .....  | 65 |
| 9.7.4  | Tertiary Efficacy Variables .....   | 66 |
| 9.7.5  | Immunogenicity.....   | 67 |
| 9.7.6  | Pharmacodynamics.....   | 67 |
| 9.7.7  | Exploratory Assessments .....   | 67 |
| 9.7.8  | Safety Variables .....  | 67 |
| 10     | REPORTING ADVERSE EVENTS .....  | 75 |
| 10.1   | Safety Parameters and Definitions.....  | 75 |
| 10.1.1 | Adverse Events.....   | 75 |
| 10.2   | Serious Adverse Events .....  | 76 |
| 10.2.1 | Events of Special Interest (EOSI) .....   | 77 |
| 10.3   | Methods and Timing for Capturing and Assessing Safety Parameters.....                     | 77 |
| 10.3.1 | Adverse Event Reporting Period.....   | 77 |
| 10.3.2 | Eliciting Adverse Events .....  | 77 |
| 10.3.3 | Assessment of Seriousness, Severity, and Causality.....                                   | 77 |
| 10.4   | Procedures for Recording Adverse Events .....   | 80 |
| 10.4.1 | Recording Adverse Events on a eCRF.....   | 80 |
| 10.5   | Reporting Requirements .....  | 83 |
| 10.5.1 | Expedited Reporting Requirements.....   | 83 |
| 10.5.2 | Institutional Review Board or Independent Ethics Committee<br>Reporting Requirements..... | 84 |



|         |  |    |
|---------|--|----|
| 10.6    | Follow-up of Subjects after Adverse Events.....                              | 84 |
| 10.7    | Post-Study Adverse Events.....   | 84 |
| 10.8    | Urgent Safety Measures.....  | 85 |
| 10.9    | BioMarin Pharmacovigilance Contact Information.....                          | 86 |
| 11      | APPROPRIATENESS OF MEASUREMENTS.....   | 87 |
| 12      | STUDY PROCEDURES.....  | 88 |
| 12.1    | Prestudy.....  | 88 |
| 12.2    | Screening Visit.....   | 88 |
| 12.2.1  | “Smart Rescreening” Visit.....   | 89 |
| 12.3    | Baseline Visit.....  | 90 |
| 12.4    | Treatment Visit/BMN 270 Infusion Visit (Day 1).....                          | 91 |
| 12.5    | BMN 270 Infusion Follow-Up Visits – Weeks 1-26.....                          | 91 |
| 12.5.1  | Once per week (Weeks 1 through 26).....                                      | 92 |
| 12.5.2  | Week 1 – Day 4.....  | 92 |
| 12.5.3  | Week 1 – Day 8.....  | 92 |
| 12.5.4  | Every 2 Weeks (Week 2, 4, 6, 8, 10, 12, 14, 16, 18, 20, 22, 24, and 26)..... | 92 |
| 12.5.5  | Weeks 2, 4, 10, 16, 22, and 26.....  | 93 |
| 12.5.6  | Weeks 2, 3, 4, 6, 8, 12, 16, 20, 24, and 26.....                             | 93 |
| 12.5.7  | Weeks 4, 12, and 26.....   | 93 |
| 12.5.8  | Every 4 Weeks (Weeks 4, 8, 12, 16, 20, and 24) Plus Week 26.....             | 93 |
| 12.5.9  | Every 8 Weeks (Weeks 8, 16, and 24).....                                     | 93 |
| 12.5.10 | Weeks 6, 13, 16, 20, 24, and 26.....   | 93 |
| 12.5.11 | Weeks 12 and 26.....   | 94 |
| 12.5.12 | Week 13 and 26.....  | 94 |
| 12.5.13 | Week 16.....   | 94 |
| 12.5.14 | Week 20, 24, and 26.....   | 94 |
| 12.6    | Post-Infusion Follow-Up – Weeks 27-52.....                                   | 94 |
| 12.6.1  | Every Visit.....   | 94 |
| 12.6.2  | Weeks 28, 30, 32, 34, 36, 44, and 52.....                                    | 95 |
| 12.6.3  | Every 4 Weeks (Weeks 28, 32, 36, 40, 44, 48, 52).....                        | 95 |



|        |  |     |
|--------|--|-----|
| 12.6.4 | Weeks 32, 36, 44, and 52 .....                                       | 95  |
| 12.6.5 | Weeks 32, 36, 40, 44, 48, and 52 .....                               | 95  |
| 12.6.6 | Week 32, 36, and 52.....   | 96  |
| 12.6.7 | Week 38 and 52.....  | 96  |
| 12.6.8 | Week 52.....   | 96  |
| 12.7   | Post-Infusion Follow-Up – Years 2-5.....                             | 96  |
| 12.7.1 | Year 2 – Every 4 Weeks.....  | 97  |
| 12.7.2 | Years 3-5 – Every 6 Weeks.....                                       | 97  |
| 12.7.3 | Years 2-5 – Every 3 Months.....                                      | 98  |
| 12.7.4 | Years 2-5 – Every 6 Months.....                                      | 99  |
| 12.8   | Early Termination Visit .....  | 100 |
| 12.9   | End of Study.....  | 101 |
| 13     | DATA QUALITY ASSURANCE.....  | 102 |
| 14     | STATISTICAL METHODS AND DETERMINATION OF SAMPLE SIZE.....            | 103 |
| 14.1   | Statistical and Analytical Plans.....                                | 103 |
| 14.1.1 | Interim Analyses.....  | 103 |
| 14.1.2 | Procedures for Accounting for Missing, Unused and Spurious Data..... | 104 |
| 14.2   | Primary Efficacy Endpoint.....                                       | 104 |
| 14.3   | Secondary Efficacy Endpoints.....                                    | 104 |
| 14.4   | Immunogenicity .....   | 105 |
| 14.5   | Pharmacodynamic Analyses .....                                       | 105 |
| 14.6   | Safety Analysis .....  | 105 |
| 14.7   | Determination of Sample Size .....                                   | 106 |
| 14.8   | Analysis Populations.....  | 107 |
| 14.9   | Changes in the Conduct of the Study or Planned Analyses.....         | 107 |
| 15     | DATA MONITORING COMMITTEE.....                                       | 108 |
| 16     | COSTS, COMPENSATION, AND SUBJECT INJURY.....                         | 109 |
| 17     | CASE REPORT FORMS AND SOURCE DOCUMENTS .....                         | 110 |
| 18     | STUDY MONITORING AND AUDITING .....                                  | 112 |
| 19     | RETENTION OF RECORDS .....   | 113 |



|  |     |
|--|-----|
| 20 USE OF INFORMATION AND PUBLICATION .....                  | 114 |
| 21 REFERENCES .....  | 115 |
| 22 INVESTIGATOR RESPONSIBILITIES .....                       | 118 |
| 22.1 Conduct of Study and Protection of Human Patients ..... | 118 |
| 23 SIGNATURE PAGE .....                                      | 119 |
| 24 APPENDIX 1: SAMPSON'S ANAPHYLAXIS CRITERIA .....          | 120 |
| 25 PROTOCOL AMENDMENT TEXT REVISIONS .....                   | 121 |

### LIST OF TABLES

|   |    |
|---|----|
| Table 9.1.1: Schedule of Events – Screening and Infusion .....  | 38 |
| Table 9.1.2: Schedule of Events – Post-Infusion Follow-Up (Week 1-16).....  | 41 |
| Table 9.1.3: Schedule of Events – Post-Infusion Follow-Up (Week 17-32).....   | 44 |
| Table 9.1.4: Schedule of Events – Post-Infusion Follow-Up (Week 33 – Year 5).....                                     | 47 |
| Table 9.1.5: Schedule of Events – Therapeutic Corticosteroids for LFT Elevations or<br>Decreased FVIII Activity ..... | 50 |
| Table 9.4.8.2.1: Adjustments to Corticosteroid Regimen.....   | 62 |
| Table 9.7.8.2.1: Clinical Laboratory Tests .....  | 69 |
| Table 9.7.8.3.1: Liver Function Tests .....   | 70 |
| Table 9.7.8.3.2: Evaluation of ALT Elevations .....   | 71 |
| Table 9.7.8.3.3: Viral and Autoimmune Hepatitis Testing .....   | 72 |
| Table 10.3.3.2.1: Adverse Event Grading (Severity) Scale .....  | 78 |
| Table 10.3.3.3.1: Causality Attribution Guidance .....  | 79 |

### LIST OF FIGURES

|   |    |
|---|----|
| Figure 7.3.1: hFVIII-SQ Vector Genome Schematic ..... | 32 |
|---|----|



## 4 LIST OF ABBREVIATIONS AND DEFINITIONS OF TERMS

### Abbreviations

|         |  |
|---------|--|
| AAV     | adeno-associated virus                                     |
| ABR     | annualized bleeding rate                                   |
| ADL     | activities of daily living                                 |
| ADR     | adverse drug reaction                                      |
| AE      | adverse event  |
| ALT     | alanine aminotransferase                                   |
| APTT    | activated partial thromboplastin time                      |
| ART     | anti-retroviral therapy                                    |
| BPV     | BioMarin Pharmacovigilance                                 |
| BU      | Bethesda Unit  |
| CFR     | Code of Federal Regulations                                |
| CRA     | clinical research associate                                |
| CRF     | case report form   |
| CSR     | clinical study report                                      |
| CTCAE   | Common Terminology Criteria for Adverse Events             |
| DMC     | Data Monitoring Committee                                  |
| eCRF    | electronic case report form                                |
| ED      | exposure days  |
| EOSI    | events of special interest                                 |
| ETV     | early termination visit                                    |
| EudraCT | European Union Drug Regulating Authorities Clinical Trials |
| FAS     | Full Analysis Set  |
| FDA     | Food and Drug Administration                               |
| FIH     | first-in-human   |
| FVIII   | coagulation factor VIII                                    |
| GCP     | Good Clinical Practice                                     |
| HA      | Hemophilia A   |
| HAL     | Haemophilia Activities List                                |
| HBcAb   | hepatitis B core antibody                                  |
| HBsAb   | hepatitis B surface antibody                               |
| HBsAg   | hepatitis B surface antigen                                |
| hFIX    | human coagulation factor IX                                |
| hFVIII  | human coagulation factor VIII                              |

---

|             |   |
|-------------|---|
| HIPAA       | Health Insurance Portability and Accountability Act   |
| IB          | investigator brochure   |
| ICF         | informed consent form   |
| ICH         | International Conference on Harmonisation of Technical Requirements for Registration of Pharmaceuticals for Human Use |
| ICH E6 [R2] | ICH Harmonised Tripartite Guideline: Guideline for Good Clinical Practice E6  |
| IEC         | independent ethics committee  |
| IND         | Investigational New Drug (application)  |
| INR         | international normalized ratio  |
| IP          | investigational product   |
| IRB         | institutional review board  |
| IV          | intravenous   |
| LFT         | liver function test   |
| MedDRA      | Medical Dictionary for Regulatory Activities  |
| MN          | mobile nursing  |
| PBMC        | peripheral blood mononuclear cells  |
| PCR         | polymerase chain reaction   |
| PD          | pharmacodynamics  |
| PEG         | polyethylene glycol   |
| PK          | Pharmacokinetics  |
| PRO         | patient-reported outcome  |
| rhFVIII     | recombinant human FVIII protein   |
| REB         | research ethics board   |
| SAE         | serious adverse event   |
| SAP         | statistical analysis plan   |
| SDV         | source data verification  |
| TGA         | thrombin generation assay   |
| ULN         | upper limit of normal   |
| vg          | vector genomes  |
| VWF:Ag      | von Willebrand factor Antigen   |
| WPAI+CIQ:HS | Work Productivity and Activity Impairment plus Classroom Impairment Questions: Hemophilia Specific                    |





**Definition of Terms:**

Investigational Product (IP):

“A pharmaceutical form of an active ingredient or placebo being tested or used as a reference in a clinical trial, including a product with a marketing authorization when used or assembled (formulated or packaged) in a way different from the approved form, or when used for an unapproved indication, or when used to gain further information about an approved use” (from International Conference on Harmonisation of Technical Requirements for Registration of Pharmaceuticals for Human Use ICH Harmonised Tripartite Guideline: Guideline for Good Clinical Practice E6 [ICH E6 (R2)]).

The terms “IP” and “study drug” may be used interchangeably in the protocol.



---

## 5 ETHICS

BioMarin Pharmaceutical Inc. (hereafter referred to as BioMarin or the Sponsor) conducts its studies according to the highest ethical and scientific standards. The following sections articulate standards to which Investigators will be held accountable, as well as matters of compliance to document adherence to such standards.

### 5.1 Institutional Review Board or Independent Ethics Committee

Investigators are expected to interact with Ethics Committees (ECs) promptly, as required, during the course of the study. This includes, but is not limited to, providing appropriate documentation to support study initiation and maintaining appropriate flow of safety and other information during the course of the study and for study close-out activities. BioMarin (or designee) will assist Investigators with access to timely and accurate information and with assurance of prompt resolution of any queries.

Prior to initiating the study, the Investigator will obtain written confirmation that the institutional review board (IRB) or independent ethics committee (IEC) [for Canadian protocols, Research Ethics Board (REB)] is properly constituted and compliant with International Conference on Harmonisation of Technical Requirements for Registration of Pharmaceuticals for Human Use (ICH) and Good Clinical Practice (GCP) requirements, applicable laws and local regulations. A copy of the confirmation from the IRB/IEC/REB will be provided to BioMarin or its designee. The Investigator will provide the IRB/IEC/REB with all appropriate material, including the protocol, Investigator's Brochure (IB), the Informed Consent Form (ICF) including compensation procedures, and any other written information provided to the subjects, including all ICFs translated for patients who do not speak the local language at the clinical site. The study will not be initiated and Investigational Product (IP) supplies will not be shipped to the site until appropriate documents from the IRB/IEC/REB confirming unconditional approval of the protocol, the ICF and all subject recruitment materials are obtained in writing by the Investigator and copies are received at BioMarin or its designee. The approval document should refer to the study by protocol title and BioMarin protocol number (if possible), identify the documents reviewed, and include the date of the review and approval. BioMarin will ensure that the appropriate reports on the progress of the study are made to the IRB/IEC/REB and BioMarin by the Investigator in accordance with applicable guidance documents and governmental regulations.

### 5.2 Ethical Conduct of Study

It is expected that Investigators understand and comply with the protocol. This includes, but is not limited to: establishing and meeting enrollment commitments, including providing



eligible subjects for study enrollment; adhering to adverse event reporting, diagnostic, or other procedures as specified in the protocol; and assuring appropriate compliance with study treatment administration and accountability.

This study will be conducted in accordance with the following:

- European Clinical Trial Directive 2001/20/EC and Good Clinical Practice Directive 2005/28/EC, for studies conducted within any European country
- US Code of Federal Regulations (CFR) sections that address clinical research studies, and/or other national and local regulations, as applicable
- ICH Harmonised Tripartite Guideline: Guideline for Good Clinical Practice E6 (ICH E6) or E6(R2) (ICH E6R2) if adopted

Specifically, this study is based on adequately performed laboratory and animal experimentation and human Phase 1 study testing. The study will be conducted under a protocol reviewed and approved by an IRB/IEC/REB and will be conducted by scientifically and medically qualified persons. The potential benefits of the study are in proportion to the potential risks. The rights and welfare of the subjects will be respected and the Investigators conducting the study do not find the hazards to outweigh the potential benefits. Each subject will provide written, informed consent before any study-related tests or evaluations are performed.

### **5.3 Subject Information and Informed Consent**

A properly written and executed informed consent form (ICF), in compliance with ICH E6 (Section 4.8), United States Code of Federal Regulations (CFR) 21 CFR §50, European Clinical Trial Directive 2001/20/EC and Good Clinical Practice Directive 2005/28/EC, and other applicable local regulations, will be obtained for each subject prior to entering the subject into the study. The Investigator will prepare the ICF and provide the documents to BioMarin for approval prior to submission to the IRB/IEC/REB. BioMarin and the IRB/IEC/REB must approve the documents before they are implemented. A copy of the approved ICF, and if applicable, a copy of the approved subject information sheet and all ICFs translated to a language other than the native language of the clinical site must also be received by BioMarin or designee prior to any study-specific procedures being performed.

The Investigator will provide copies of the signed ICF to each subject and will maintain the original in the record file of the subject.



## 6 INVESTIGATORS AND STUDY ADMINISTRATIVE STRUCTURE

During administration of informed consent, expectations regarding participation in the study should be made clear to subjects. Patients who are not willing and/or are not able to comply with all aspects of the study should not be encouraged to participate.

Prior to beginning the study, the Investigator at each site must provide to BioMarin or designee a fully executed and signed Statement of Investigator (SOI) form. A US Food and Drug Administration (FDA) Form FDA 1572 serves as an acceptable SOI form. If Form FDA 1572 may not be used in a particular region, the Investigator must provide a fully executed SOI on the form provided by the Sponsor. All Investigators and Sub-Investigators must be listed on Form FDA 1572 or its equivalent SOI. Financial Disclosure Forms must also be completed for all Investigators and Sub-Investigators listed on the Form FDA 1572 or SOI who will be directly involved in the treatment or evaluation of subjects in this study.

The study will be administered by and monitored by employees or representatives of BioMarin. Clinical research associates (CRAs) or trained designees will monitor each site on a periodic basis and perform verification of source documentation for each subject as well as other required review processes. BioMarin's Regulatory Affairs Department (or designee) will be responsible for the timely reporting of serious adverse events (SAEs) to appropriate regulatory authorities as required.

In multicenter studies, a Coordinating Investigator will be identified who will be responsible for study overview. The Coordinating Investigator will read the clinical study report (CSR) and confirm that it accurately describes the conduct and results of the study, to the best of his or her knowledge. The Coordinating Investigator will be chosen on the basis of active participation in the study, ability to interpret data, and willingness to review and sign the report in a specified timeframe. The identity of the Coordinating Investigator and a list of all Investigators participating in the study will be provided in the CSR.

Clinical Laboratory assessments will be performed at a nominated central laboratory. Bioanalytical samples will be sent to the appropriate specialty laboratories for testing. Refer to laboratory manual for more details.

## 7 INTRODUCTION

Hemophilia A (HA) is an X-linked recessive bleeding disorder that affects approximately 1 in 5,000 males (Nathwani, 1992, *Baillieres Clin.Haematol.*). It is caused by mutations in the factor VIII (FVIII) gene that codes for FVIII protein, an essential cofactor in the coagulation pathway. Clinical manifestations of severe FVIII deficiency are frequent unprovoked bleeding episodes in joints and soft tissues causing permanent disability and occasionally death mostly after brain hemorrhage. Treatment in Western countries (Berntorp, 2012, *Haemophilia.*) consists of intravenous injection of plasma-derived or recombinant FVIII protein concentrates at the time of a bleed to control it or prophylactically to prevent bleeding episodes. The short half-life for FVIII (~8-12 hours) necessitates frequent infusions and makes this treatment prohibitively expensive for the majority of the world's hemophilia A patients. These individuals develop debilitating arthropathy and have a substantially increased risk of death from hemorrhage in life (Stonebraker, 2010, *Haemophilia.*). Chemical modification or bioengineering of FVIII may improve half-life to 18-19 hours (Kaufman, 2013, *Blood*). However, these extended half-life FVIII variants do not eliminate the need for lifelong FVIII protein administration (Hay, 2012, *Blood*).

Gene therapy offers the potential of disease-modifying therapy by continuous endogenous production of human FVIII (hFVIII) following a single administration of vector. Hemophilia A is well-suited for this approach because its clinical manifestations are attributable to the lack of a single gene product (FVIII) that circulates in low amounts (100-200 ng/ml) in the plasma. Tightly regulated control of gene expression is not essential, and a modest increase in the level of FVIII (a plasma level of 2 ng/ml protein leads to a 1% expression) can ameliorate the severe phenotype (Srivastava, 2013, *Haemophilia.*); thus, the therapeutic goal for gene therapy is a modest increase in hFVIII. Finally, the consequences of gene transfer can be assessed using simple quantitative rather than qualitative endpoints that can be easily assayed in most clinical laboratories.

BMN 270 contains the cDNA for the B-domain-deleted SQ FVIII with a liver-specific HLP transcription promoter. The expression cassette is inserted between AAV2 ITRs, and this genome is packaged in the AAV5 capsid. A comprehensive review of BMN 270 is contained in the IB supplied by BioMarin. Investigators are to review this document prior to initiating this study.

### 7.1 Nonclinical Studies

The nonclinical program supports a single IV infusion of BMN 270, the planned clinical route of administration, for the treatment of hemophilia A in male patients. This nonclinical



program took into account the guidelines and reflection papers for gene therapy medicinal products under EMA Advanced Therapies as well as FDA guidance. The primary pharmacodynamics (PD), pharmacokinetics (PK), and toxicity of IV BMN 270 were characterized in a series of single dose studies in species that were vector permissive and responsive to the transgene including normal CD-1 mice, a B- and T-cell deficient mouse model of hemophilia A (B6;129S-*F8<sup>tm1Kaz</sup>*/J x B6.129S6-*Rag2<sup>tm1Fwa</sup>* N12; FVIII KO x Rag2), and normal cynomolgus and rhesus monkeys. Some PD studies evaluated additional PK, immunogenicity and toxicity endpoints.

Results of the nonclinical program to date are detailed in the IB supplied by BioMarin. Investigators are to review this document prior to initiating this study.

## 7.2 Previous Clinical Studies

Study BMN 270-201 is an ongoing Phase 1/2, dose-escalation study to assess the safety, tolerability, and efficacy of BMN 270 in patients with severe hemophilia A (FVIII  $\leq 1$  IU/dL). Subjects received a single BMN 270 infusion and are to be followed for safety and efficacy for up to 5 years. A total of 15 subjects have been enrolled at one of 4 dose levels (6E12, 2E13, 4E13, and 6E13 vg/kg).

A comprehensive review of safety, efficacy, and immunogenicity results from 270-201 as of the latest data cut is contained in the IB supplied by BioMarin. Investigators are to review this document prior to initiating this study.

## 7.3 Study Rationale

Hemophilia A (HA) is an X-linked recessive bleeding disorder that affects approximately 1 in 5,000 males. It is caused by deficiency in the activity of coagulation factor VIII (FVIII), an essential cofactor in the intrinsic coagulation pathway. This disorder can be either inherited, due to a genetic aberrancy or an acquired immunologic process, leading to insufficient quantities of FVIII or a dysfunctional FVIII, but all are characterized by a defective coagulation process. The clinical phenotype of HA patients generally correlates tightly with the level of residual expression. Severe HA is classified as FVIII activity less than 1% of wild type ( $< 1$  IU/dL), moderate disease comprises 1-5% of wild-type activity and the mild form is 5-40% activity. The clinical manifestations of severe HA are frequent spontaneous bleeding episodes, predominantly in joints and soft tissues, with a substantially increased risk of death from hemorrhage when the brain is involved. Subjects with moderate disease can exhibit manifestations similar to those seen in patients with severe HA, resulting in a comparable bleeding phenotype.



Treatment of severe HA presently consists of intravenous injection of plasma derived or recombinant human FVIII protein (rhFVIII) concentrates both as prophylaxis 2-3 times per week, and at the time of a bleed, to prevent or control bleeding episodes, respectively. The half-life for FVIII (12 to 18 hours for most approved products) necessitates frequent infusions, and although a major advance in the treatment of HA, it remains common for severe HA patients to continue to have multiple bleeding events on prophylactic therapy (median ABR of 1-4 with prophylaxis treatment in a recently published retrospective observational study (Berntorp, 2017) and between 1-2 in 6 prospective FVIII interventional studies) and on-demand-only therapy (median ABR of 4.5-18 in a recently published retrospective study (Berntorp, 2017) and between 20-60 in 6 prospective FVIII interventional studies). The consequence of multiple bleeding events is the development of debilitating multiple-joint arthropathy and substantially increased risk of death. Chemical modification (eg, direct conjugation of polyethylene glycol (PEG) polymers) and bioengineering of FVIII (eg, FVIII-Fc fusion proteins) improve half-life by approximately 50%, and thus, show promise in reduced dosing and maintaining activity levels above 1% trough for a greater proportion of the dosing interval. However, these extended half-life FVIII variants remain dependent on multiple infusions to maintain critical levels of FVIII activity in severe HA patients. There is therefore a strong unmet need for a fully preventive treatment of HA to give patients a FVIII level compatible with a normal and hemorrhage-free life.

Gene therapy offers the potential of disease-modifying therapy by continuous endogenous production of active FVIII following a single intravenous infusion of a vector encoding the appropriate gene sequence for long-term episomal expression. Hemophilia A is well-suited for a gene replacement approach because clinical manifestations are attributable to the lack of a single gene product (FVIII) that circulates in minute amounts (200 ng/ml) in the plasma. Tightly regulated control of gene expression is not essential, and even modest increases in the level of FVIII (any increase of the plasma level by 2 ng/ml induces an increase in activity of 1%) can ameliorate the severe form of the disease. Thus, relatively small changes in endogenous FVIII activity can result in clinically relevant improvements in disease phenotype. Finally, the circulating FVIII response to gene transduction can be assessed using validated quantitative rather than qualitative endpoints that are easily assayed using established laboratory techniques.

Several different gene transfer strategies for FVIII replacement have been evaluated, but adeno-associated viral (AAV) vectors show the greatest promise. They have an excellent and well-defined safety profile, and can direct long term transgene expression with tropism and promoter specificity for specific tissues such as the liver (for serotypes 2, 5 and 8 among



others). Indeed, an on-going gene therapy clinical trial for a related disorder, hemophilia B, has established that stable (median follow-up of 3.2 years) expression of human factor IX (hFIX) at levels that are sufficient for conversion of their bleeding phenotype from severe to moderate or mild is achievable following a single peripheral vein infusion of AAV8-hFIX vector. Several participants in this trial have been able to discontinue factor prophylaxis without suffering spontaneous hemorrhages, even when they undertook activities that previously resulted in bleeding. Thus, gene therapy treatment has resulted in a substantial improvement in their quality of life (Nathwani, 2014).

BMN 270 is an AAV5-based gene therapy vector that expresses the SQ form of hFVIII under the control of a hybrid human liver-specific promoter (Figure 7.3.1).

**Figure 7.3.1: hFVIII-SQ Vector Genome Schematic**

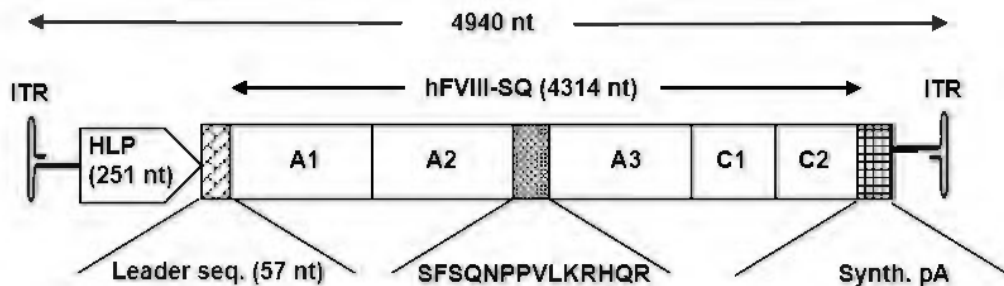

Legend –Note that schematic is not to scale; nt = nucleotides

BMN 270 will be delivered by a single intravenous dose and is designed to achieve stable, potentially life-long expression of active hFVIII in the plasma, synthesized from vector-transduced liver tissue.

BMN 270 is being evaluated in clinical study 270-201, an ongoing first-in-human, phase 1/2 dose escalation study in subjects with severe HA designed to assess the safety and efficacy of BMN 270 at various dose levels (6E12 vg/kg, 2E13 vg/kg, 4E13 vg/kg, 6E13 vg/kg).

Specifically, 270-201 explores the relationship of vector dose to the augmentation of residual FVIII activity and whether these levels are sufficient to alter the clinical phenotype.

Preliminary results from 270-201 have demonstrated that following gene transfer, FVIII activity above 15% (15 IU/dL) and, in many cases, within the normal range for FVIII, is achievable with a dose of 4-6E13 vg/kg with an acceptable safety profile (Pasi, 2017). For additional information on preliminary data in 270-201, refer to the current version of the Investigator's Brochure.





The current study is a Phase 3, single-arm, open-label study designed to assess whether, in an expanded sample, BMN 270 can safely alter the clinical phenotype of hemophilia A patients with residual FVIII activity  $\leq 1$  IU/dL.

#### 7.4 Summary of Overall Risks and Benefits

The majority of subjects in the ongoing 270-201 clinical study who have received 4E13 or 6E13 vg/kg doses of BMN 270 have had Grade 1 asymptomatic elevations in ALT. For most subjects, the elevations have reached only slightly above the ULN. Based on the effectiveness of transient oral corticosteroid used to suppress a presumed cytotoxic T-cell response in prior studies with hepatic transduction with AAV vectors (Mingozi, 2013), subjects were treated with 7-32 weeks of oral corticosteroids preventatively or in response to the elevations in ALT to ensure preservation of the transduced hepatocytes. Using this approach, no sustained loss of FVIII activity has been observed in subjects with ALT elevations, consistent with maintaining a high level of hepatocyte function. Moreover, the rise in ALT levels were not accompanied by significant or lasting aberrations in other liver function tests such as AST, bilirubin or albumin, indicating that extent of toxicity is limited. Overall, the literature suggests that transient elevations in liver enzymes are expected following AAV-based gene therapy for the treatment for hemophilia B without any long-term concerns of hepatic injury (Manno, 2006); (Nathwani, 2011); (George, 2016); (Miesbach, 2016).

At the highest dose tested in 270-201 (6E13 vg/kg), the majority of subjects achieved FVIII levels above 50 IU/dL at 52 weeks post-infusion. Subjects in that cohort also reported markedly decreased bleeding compared with pre-study rates and the ability to discontinue prophylactic FVIII infusions. Subjects at all dose levels continue to be followed.

As with any infused biological product, there is a potential risk of acute, systemic hypersensitivity reactions (including anaphylaxis) with BMN 270. No hypersensitivity reactions were observed during dosing of BMN 270 in the 270-201 clinical study, although one SAE of pyrexia was reported approximately 16 hours after the infusion in a subject in the 4E13 vg/kg cohort. The subject was treated with acetaminophen, and the fever resolved within 48 hours (see Investigator's Brochure for full details). Infusion-related reactions, including allergic reaction, maculopapular rash, and presyncope, have been reported from ongoing, actively dosing clinical studies of BMN 270, including this study. All of the infusion-related reactions were effectively managed clinically and resolved without any clinical sequelae. Refer to the Investigator's Brochure for additional details.



---

The current data available for BMN 270 does not yet permit adequate assessment of the benefit:risk profile of this investigational drug. Given the monitoring measures in place in the clinical protocol(s) to minimize the risk to subjects participating in the existing studies, the identified risks are justified by the anticipated benefits that may be afforded to subjects. Each subject in 270-301 will have a comprehensive surveillance plan that monitors LFTs during the study, and elevations in LFT will be addressed according to the guidelines set forth in the protocol. Safety will be assessed by adverse event reporting and clinical laboratory assessments.

For additional information on findings in 270-201, refer to the current version of the Investigator's Brochure.



## 8 STUDY OBJECTIVES

The primary efficacy objective of the study is to:

- Assess the efficacy of BMN 270 defined as FVIII activity, as measured by one-stage clotting assay, during Weeks 49-52 following intravenous infusion of BMN 270

The secondary efficacy objectives of the study are to:

- Assess the impact of BMN 270 on usage of exogenous FVIII replacement therapy from Week 5 to Week 52
- Assess the impact of BMN 270 on the number of bleeding episodes requiring exogenous FVIII replacement therapy from Week 5 to Week 52

The tertiary efficacy objective of the study is to:

- Assess the impact of BMN 270 on patient-reported outcomes (PROs) at Week 52 of the study compared to baseline

The safety objectives of the study are to:

- Evaluate the safety of BMN 270 during the first 52 weeks following intravenous infusion
- Assess the long-term safety of BMN 270

## 9 INVESTIGATIONAL PLAN

### 9.1 Overall Study Design and Plan

This is a Phase 3, single-arm, open-label study in hemophilia A patients with residual FVIII levels  $\leq 1$  IU/dL treated continuously with prophylactic exogenous FVIII for a minimum of one year prior to enrollment. Subjects will be enrolled at approximately 60 sites worldwide. Subjects must have high-quality, well-documented historical data available concerning previous bleeding episodes and exogenous FVIII usage over the previous 12 months in order to be eligible to enroll in the study.

Approximately 130 adult subjects with severe HA will receive a 6E13 vg/kg dose of BMN 270 as a single intravenous infusion. Approximately 20 subjects will enroll in the study with at least 12 months of well-documented high-quality historical data concerning previous bleeding episodes and exogenous FVIII usage, while approximately 110 subjects will enroll in the study after having completed approximately 6 months' participation in the BioMarin-sponsored non-interventional study 270-902.

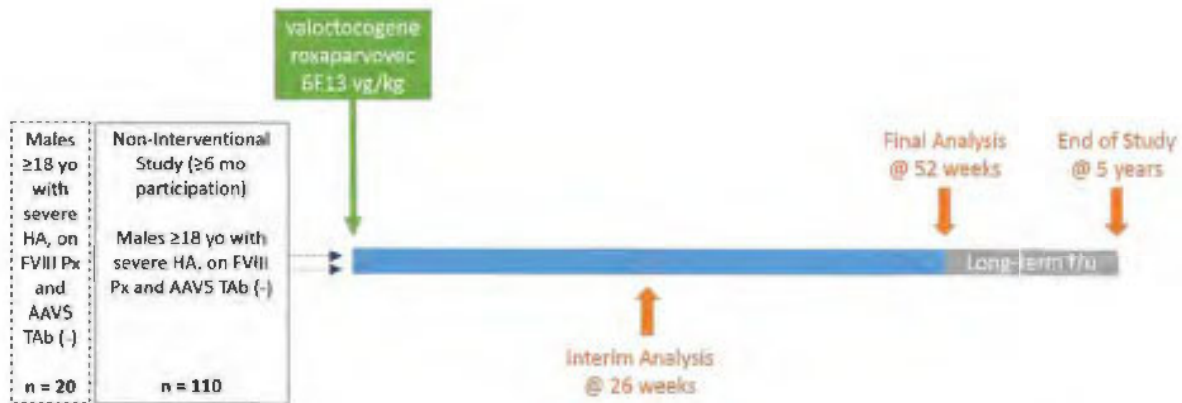

yo = years old, HA = hemophilia A, FVIII = factor VIII, Px = prophylaxis, AAVS = adeno-associated virus, serotype 5, TAB = total antibody mo = month, vg = vector genomes, kg = kilogram, f/u = follow-up

The Data Monitoring Committee (DMC) will review available safety and efficacy (eg, FVIII activity) data during the study on an ongoing basis and may determine, based on emerging data and the risk/benefit profile, that further enrollment at 6E13 vg/kg should be discontinued in favor of a different dose of BMN 270, not to exceed 6E13 vg/kg. If the DMC recommends a dosing modification, then additional subjects may be enrolled, up to a total of approximately 130 subjects, at the new BMN 270 dose level (regardless of the number of subjects previously enrolled at 6E13 vg/kg).

An interim analysis is planned after 20 treated subjects have completed the Week 26 visit.



---

The final analysis for the study will be performed after all subjects have been followed for 52 weeks post-BMN 270 infusion. After the final analysis, safety and efficacy will then continue to be assessed long-term in all subjects for a total of approximately 5 years.

To avoid breakthrough bleeding, subjects will only discontinue exogenous prophylactic FVIII replacement therapy after FVIII activity has reached at least 5 IU/dL or 4 weeks following infusion of BMN 270, whichever is earlier. Four weeks represents the time by which endogenous production of FVIII following gene transfer is expected to be efficacious.

Throughout the study, subjects with FVIII activity below 5 IU/dL may be monitored more frequently at the discretion of the Medical Monitor and the Investigator. In subjects who show an initial response to BMN 270 but who later have FVIII activity decline to < 5 IU/dL, the investigator and Medical Monitor will review the subject's FVIII activity level trends (not specific FVIII activity levels) and discuss whether to resume prior FVIII prophylaxis. In addition, the investigator will notify the subject of his FVIII activity levels and will discuss with the subject the risk of bleeding and when (and if) prior FVIII prophylaxis will be resumed.

There will be an ongoing review of individual subject safety by the Medical Monitor, and both safety and efficacy data by the DMC. FVIII activity by a validated assay will be used to evaluate efficacy over the course of the study. Therapeutic oral corticosteroids may be initiated when a subject's ALT values are elevated or based on review of FVIII activity and liver enzyme data, and subsequent dosage adjustments made, after consultation between the Investigator and the Medical Monitor. Management of ALT elevations is discussed in more detail in Section 9.7.8.3.

Any safety signal may trigger a review of the data and possible additional immunogenicity studies or other diagnostics deemed necessary that include an assessment of cellular immune responses using collected peripheral blood mononuclear cells (PBMCs).

Schedules of assessments for the Screening and Infusion period (Table 9.1.1), Post-Infusion follow-up periods (Table 9.1.2, Table 9.1.3, Table 9.1.4), and during the use of oral corticosteroids (Table 9.1.5) are presented below.

**Table 9.1.1: Schedule of Events – Screening and Infusion**

| Assessment  | Prior to BMN 270 Infusion                  |  |  | BMN 270 Infusion Visit (Day 1) <sup>k</sup> |
|---|--|--|--|---|
|   | Screening <sup>*</sup> (Day -28 to Day -1) | Smart Rescreening <sup>i</sup> (Day -28 to Day -1) | Baseline (Day -7 to Day -1) <sup>h</sup> |   |
| Informed consent  | X  |  |  |   |
| Demographics (age, sex, race, ethnicity)  | X  |  |  |   |
| Medical History   | X  |  |  |   |
| Physical Examination <sup>a</sup>   | X  |  | X  | X   |
| Height and Weight   | X  |  |  |   |
| Vital Signs   | X  | X  | X  | X   |
| Assessment of Adverse Events and Concomitant Medications  | X  | X  | X  | X   |
| Documentation of bleeding episodes and FVIII usage for previous 12 months (by either subject or clinical information) | X  | X  | X  |   |
| Distribution of subject diaries and training in their use <sup>l</sup>  | X  |  |  |   |
| Electrocardiogram   | X  |  |  |   |
| Liver Ultrasound  | X  |  |  |   |
| hFVIII Assays <sup>b</sup>  | X  | X <sup>i</sup>                                     | X  |   |
| AAV5 TAb Assays <sup>c</sup>  | X  | X  | X  | X   |
| AAV5 TI Assay   |  |  | X  |   |
| Screen for Hepatitis B, Hepatitis C, HIV <sup>d</sup>   | X  |  |  |   |
| Blood chemistry, hematology, and coagulation tests <sup>e</sup>   | X  | X  | X  |   |
| Fasting lipid panel (blood triglycerides, total cholesterol, HDL cholesterol, and LDL cholesterol)                    |  |  |  | X   |
| Urine Tests <sup>e</sup>  | X  | X  | X  |   |
| Liver Function Tests <sup>e</sup>   | X  | X  | X  |   |



| Assessment  | Prior to BMN 270 Infusion      |  |  | BMN 270 Infusion Visit (Day 1) <sup>k</sup> |
|---|--------------------------------|--|--|---|
|   | Screening* (Day -28 to Day -1) | Smart Rescreening <sup>i</sup> (Day -28 to Day -1) | Baseline (Day -7 to Day -1) <sup>h</sup> |   |
| PBMC collection (for baseline determination of AAV5 and FVIII specific cellular immunity) |                                |  | X  |   |
| Von Willebrand Factor Antigen (VWF:Ag)  |                                |  | X  |   |
| Direct Thrombin Activity Test <sup>e</sup>  |                                |  | X  |   |
| TGA Assay <sup>g</sup>  |                                |  | X  |   |
| PCR of vector DNA in blood, saliva, urine, semen, and stools                              |                                |  | X  | X   |
| Biomarker testing <sup>f</sup>  | X                              |  |  |   |
| Exploratory biomarker assessments <sup>g</sup>  |                                |  | X  |   |
| Haemo-QOL-A assessment  |                                |  | X  |   |
| EQ-5D-5L  |                                |  | X  |   |
| HAL   |                                |  | X  |   |
| WPAI+CIQ:HS   |                                |  | X  |   |
| PROBE   |                                |  | X  |   |
| BMN 270 Infusion  |                                |  |  | X   |
| Hypersensitivity blood assessments <sup>m</sup>   |                                |  |  | X <sup>m</sup>                              |

\* Screening assessments should be performed within 28 days of BMN 270 infusion (and must be performed within 42 days prior to BMN 270 infusion).

<sup>a</sup> Complete physical examination should be done at Screening. Brief physical examination may be done at Baseline and at the BMN 270 Infusion Visit.

<sup>b</sup> Includes baseline FVIII activity (chromogenic FVIII assay and one-stage clot FVIII assay), coagulation exploratory assay, hFVIII inhibitor level (Bethesda assay with Nijmegen modification), hFVIII total antibody titer, and hFVIII protein assay. Baseline activity should be assessed at trough (at least >72 hours after last dose of replacement FVIII therapy, or 5x the known half-life of the FVIII concentrates administered).

<sup>c</sup> Sample collection on the day of the infusion visit must be performed before the BMN 270 infusion is given. Screening, Smart Re-screening, and Infusion Day samples will be tested in an AAV5 Tab pre-screening assay specifically developed for enrolment purposes. Baseline and all post-dose samples will be tested in a different AAV5 Tab post-dose immunogenicity monitoring assay



- <sup>d</sup> Patients with documented negative results within the last 30 days do not need to be retested. Hepatitis B screening should include hepatitis B surface antigen (HBsAg), hepatitis B surface antibody (HBsAb), and hepatitis B core antibody (HBcAb).
- <sup>e</sup> Refer to [Table 9.7.8.2.1](#) for laboratory assessments to be included, and to [Table 9.7.8.3.1](#) for liver function tests.
- <sup>f</sup> Includes HLA genotyping and FVIII genotyping.
- <sup>g</sup> Blood samples will be collected to evaluate biochemical, molecular, cellular, ABO blood typing, and genetic/genomic aspects relevant to hemophilia A, coagulation, and/or AAV gene transfer, and to develop assays used for these evaluations. Subjects may choose to opt out of the exploratory genetic/genomic research being done to study or try to discover genes that are not yet known to be associated with hemophilia A. While exploratory samples will be collected at the time points indicated above, testing of these samples (including those for TGA assay, Direct Thrombin Activity test, and any other exploratory assessments) will be performed only as deemed necessary by the Sponsor.
- <sup>h</sup> Should the screening visit occur within 30 days of the drug infusion, physical examination, blood chemistry, LFTs, hematology, urine tests, and coagulation tests do not need to be repeated at Baseline.
- <sup>i</sup> Smart rescreening should only be performed if a patient has been determined to be eligible for the study and is unable to complete the Baseline assessments and Infusion prior to the closing of the original Screening window. Subjects who undergo smart rescreening must complete the rescreening assessments and receive the infusion within 90 days of signing the original consent. Subjects who do not complete dosing within 90 days will be required to re-consent and undergo all screening procedures. Subjects may not undergo smart rescreening more than once.
- <sup>j</sup> Only the hFVIII inhibitor level (Bethesda assay with Nijmegen modification) assay must be done at smart rescreening.
- <sup>k</sup> With the exception of the collection of samples for PCR vector DNA analysis, assessments on the day of infusion must be performed prior to the infusion. Subjects will fast for at least 8 hours prior to pre-infusion laboratory sampling on the day of the infusion visit. On the day of the BMN 270 Infusion, vital signs will be monitored prior to the infusion, during the infusion every 15 minutes ( $\pm$  5 minutes), and following the infusion hourly ( $\pm$  5 minutes) for at least 8 hours during the subject's stay in the clinic. Shedding samples for PCR of vector DNA analysis (blood, saliva, urine, semen, stool) should be collected between 2 and 24 hours after the infusion has been completed.
- <sup>l</sup> Diaries should be distributed to subjects who have consented to participate in the study and who have been determined to meet all study eligibility criteria.
- <sup>m</sup> In case of hypersensitivity or adverse drug reaction, safety assessment, including physical examination and vital signs, will be done and additional blood samples will be collected within 1 hour of the hypersensitivity reaction (eg, tryptase, C3, C3a, C4, C5, and C5a, as well as possible additional exploratory testing) and one sample for IgE (and possible additional exploratory testing) between 8-24 hours after the reaction, if possible. In-patient observation can be extended and additional blood samples can be collected if deemed necessary at the discretion of the Investigator and Medical Monitor.



**Table 9.1.2: Schedule of Events – Post-Infusion Follow-Up (Week 1-16)**

| Assessment  | Follow-Up After BMN 270 Infusion – Weeks* |    |    |    |    |    |    |    |    |    |    |    |    |    |    |     |     |
|---|---|----|----|----|----|----|----|----|----|----|----|----|----|----|----|-----|-----|
|   | Week 1                                    |    | 2  | 3  | 4  | 5  | 6  | 7  | 8  | 9  | 10 | 11 | 12 | 13 | 14 | 15  | 16  |
|   | D4  | D8 |    |    |    |    |    |    |    |    |    |    |    |    |    |     |     |
| Study Day*  | 4   | 8  | 15 | 22 | 29 | 36 | 43 | 50 | 57 | 64 | 71 | 78 | 85 | 92 | 99 | 106 | 113 |
| Physical examination <sup>a</sup>   |   | X  | X  | X  | X  | X  | X  | X  | X  | X  | X  | X  | X  | X  | X  | X   | X   |
| Weight <sup>a</sup>   |   |    |    |    | X  |    |    |    | X  |    |    |    | X  |    |    |     | X   |
| Assessment of Adverse Events and Concomitant Medications (including review of subject diary for bleeding and FVIII use) |   | X  | X  | X  | X  | X  | X  | X  | X  | X  | X  | X  | X  | X  | X  | X   | X   |
| Vital Signs   |   | X  | X  | X  | X  | X  | X  | X  | X  | X  | X  | X  | X  | X  | X  | X   | X   |
| Blood chemistry, hematology, and coagulation tests <sup>b</sup>   |   |    | X  |    | X  |    |    |    |    |    | X  |    |    |    |    |     | X   |
| Urine Tests <sup>b</sup>  |   |    |    |    |    |    |    |    |    |    |    |    | X  |    |    |     |     |
| Liver Function Tests <sup>b</sup>   | X   | X  | X  | X  | X  | X  | X  | X  | X  | X  | X  | X  | X  | X  | X  | X   | X   |
| FVIII assays <sup>c</sup>   |   | X  | X  | X  | X  | X  | X  | X  | X  | X  | X  | X  | X  | X  | X  | X   | X   |
| FVIII antibody titer  |   |    |    |    | X  |    |    |    | X  |    |    |    | X  |    |    |     | X   |
| PCR of vector DNA in blood, saliva, urine, semen, and stools <sup>d</sup>   | X   | X  | X  | X  | X  |    | X  |    | X  |    |    |    | X  |    |    |     | X   |
| Exploratory biomarker assessments <sup>e</sup>  |   |    |    |    |    |    | X  |    |    |    |    |    |    | X  |    |     | X   |
| Haemo-QOL-A assessment  |   |    |    |    | X  |    |    |    |    |    |    |    | X  |    |    |     |     |
| EQ-5D-5L  |   |    |    |    | X  |    |    |    |    |    |    |    | X  |    |    |     |     |



| Assessment  | Follow-Up After BMN 270 Infusion – Weeks* |    |    |    |    |    |    |    |    |    |    |    |    |    |    |     |                |
|---|---|----|----|----|----|----|----|----|----|----|----|----|----|----|----|-----|----------------|
|   | Week 1                                    |    | 2  | 3  | 4  | 5  | 6  | 7  | 8  | 9  | 10 | 11 | 12 | 13 | 14 | 15  | 16             |
|   | D4  | D8 |    |    |    |    |    |    |    |    |    |    |    |    |    |     |                |
| Study Day*  | 4   | 8  | 15 | 22 | 29 | 36 | 43 | 50 | 57 | 64 | 71 | 78 | 85 | 92 | 99 | 106 | 113            |
| HAL   |   |    |    |    | X  |    |    |    |    |    |    |    | X  |    |    |     |                |
| WPAI+CIQ:HS   |   |    |    |    | X  |    |    |    |    |    |    |    | X  |    |    |     |                |
| PROBE   |   |    |    |    | X  |    |    |    |    |    |    |    | X  |    |    |     |                |
| AAV5 Tab Assay  |   |    |    |    |    |    |    |    | X  |    |    |    |    |    |    |     | X              |
| AAV5 TI Assay   |   |    |    |    |    |    |    |    | X  |    |    |    |    |    |    |     | X              |
| Testing for reactivation of hepatitis B and hepatitis C                 |   |    |    |    |    |    |    |    |    |    |    |    |    |    |    |     | X <sup>f</sup> |
| PBMC collection (for determination of AAV5 and FVIII specific immunity) |   |    | X  |    | X  |    | X  |    | X  |    | X  |    | X  |    | X  |     | X              |
| VWF:Ag  |   |    |    |    |    |    |    |    |    |    |    |    |    | X  |    |     |                |
| Direct Thrombin Activity test <sup>c</sup>                              |   |    |    |    |    |    |    |    |    |    |    |    |    | X  |    |     |                |

\* Visit windows are  $\pm$  48 hours (and include the Day 4 visit).

<sup>a</sup> Brief physical examination should be done at all weekly visits.

<sup>b</sup> Refer to [Table 9.7.8.2.1](#) for laboratory assessments to be included, and to [Table 9.7.8.3.1](#) for liver function tests. LFTs may be monitored more or less frequently (and in particular when ALT values are  $>1.5x$  ULN) based on discussion between the Medical Monitor and the Investigator and review of subject data, but LFTs will be monitored at least twice weekly during periods when a subject's ALT is  $\geq 3x$  ULN. Subjects with ALT  $> 1.5x$  ULN during the study and either an alternative etiology considered or for further evaluation of the lab abnormality may undergo additional evaluations (eg, imaging studies including MRI or ultrasound, additional blood tests, and/or liver biopsy) at the discretion of the Investigator. Additional testing of FVIII and LFTs during any study week may be performed if: (1) the ALT has increased to above ULN; (2) Increases in ALT values from prior assessment are accompanied by declines in FVIII activity level; or after a discussion between the Medical Monitor and the Investigator based on a review of subject data. If FVIII levels and/or ALT values are stable over the course of several weeks, assessment of FVIII activity and liver enzymes may be adjusted based on discussion between the Medical Monitor and the Investigator.

<sup>c</sup> Includes FVIII activity level (chromogenic FVIII assay and one-stage clot FVIII assay), Bethesda assay (with Nijmegen modification) for hFVIII inhibitor level, coagulation exploratory assay, and hFVIII protein assay. If a subject has used FVIII within 72 hours of a measurement day, all efforts should be made to obtain FVIII activity measurements when a 72-hour interval without FVIII use is achieved; the 72-hour wash-out period is only intended for subjects who have achieved FVIII  $\geq 5$  IU/dL at 16 weeks after BMN 270 infusion and who have



---

not resumed FVIII replacement therapy. If FVIII levels are elevated or stable over the course of several weeks, assessment of FVIII activity may be adjusted based on discussion between the Medical Monitor and the Investigator. A D-dimer may be considered under circumstances in which FVIII activity levels are above the normal physiological range and/or if there is a concern for a venous thromboembolism.

- <sup>d</sup> Collection for each matrix to occur until at least 3 consecutive negative results are obtained. Collection and testing of semen samples must continue at least through Week 12, even if 3 consecutive negative results in that compartment have already been recorded.
- <sup>e</sup> Blood samples will be collected to evaluate biochemical, molecular, cellular, and genetic/genomic aspects relevant to hemophilia A, coagulation, and/or AAV gene transfer, and to develop assays used for these evaluations. Subjects may choose to opt out of the exploratory genetic/genomic research being done to study or try to discover genes that are not yet known to be associated with hemophilia A. While exploratory samples will be collected at the time points indicated above, testing of these samples (including those for TGA assay, Direct Thrombin Activity test, and any other exploratory assessments) will be performed only as deemed necessary by the Sponsor.
- <sup>f</sup> Testing for reactivation of hepatitis B and hepatitis C at Week 16, for subjects with a past medical history of hepatitis B or hepatitis C prior to study entry, should be performed only in subjects who have not received therapeutic oral corticosteroids prior to Week 16; subjects who have received therapeutic oral corticosteroids will have hepatitis B and hepatitis C testing at the time points indicated in [Table 9.1.5](#).

**Table 9.1.3: Schedule of Events – Post-Infusion Follow-Up (Week 17-32)**

| Assessment  | Follow-Up After BMN 270 Infusion – Weeks* |     |     |     |     |     |     |     |     |     |     |     |     |     |     |     |
|---|---|-----|-----|-----|-----|-----|-----|-----|-----|-----|-----|-----|-----|-----|-----|-----|
|   | 17  | 18  | 19  | 20  | 21  | 22  | 23  | 24  | 25  | 26  | 27  | 28  | 29  | 30  | 31  | 32  |
| Study Day*  | 120                                       | 127 | 134 | 141 | 148 | 155 | 162 | 169 | 176 | 183 | 190 | 197 | 204 | 211 | 218 | 225 |
| Physical examination <sup>a</sup>   | X   | X   | X   | X   | X   | X   | X   | X   | X   | X   | X   | X   | X   | X   | X   | X   |
| Weight <sup>a</sup>   |   |     |     | X   |     |     |     | X   |     |     |     | X   |     |     |     | X   |
| Assessment of Adverse Events and Concomitant Medications (including review of subject diary for bleeding and FVIII use) | X   | X   | X   | X   | X   | X   | X   | X   | X   | X   | X   | X   | X   | X   | X   | X   |
| Vital Signs   | X   | X   | X   | X   | X   | X   | X   | X   | X   | X   | X   | X   | X   | X   | X   | X   |
| Blood chemistry, hematology, and coagulation tests <sup>b</sup>   |   |     |     |     |     | X   |     |     |     | X   |     |     |     |     |     | X   |
| Urine Tests <sup>b</sup>  |   |     |     |     |     |     |     |     |     | X   |     |     |     |     |     |     |
| Liver Function Tests <sup>b</sup>   | X   | X   | X   | X   | X   | X   | X   | X   | X   | X   | X   | X   | X   | X   | X   | X   |
| FVIII assays <sup>c</sup>   | X   | X   | X   | X   | X   | X   | X   | X   | X   | X   | X   | X   | X   | X   | X   | X   |
| FVIII antibody titer  |   |     |     | X   |     |     |     | X   |     | X   |     |     |     |     |     | X   |
| PCR of vector DNA in blood, saliva, urine, semen, and stools <sup>d</sup>   |   |     |     | X   |     |     |     | X   |     | X   |     |     |     |     |     | X   |
| Exploratory biomarker assessments <sup>e</sup>  |   |     |     | X   |     |     |     | X   |     | X   |     |     |     |     |     | X   |



| Assessment   | Follow-Up After BMN 270 Infusion – Weeks* |     |     |     |     |     |     |     |     |     |     |     |     |     |     |     |
|--|---|-----|-----|-----|-----|-----|-----|-----|-----|-----|-----|-----|-----|-----|-----|-----|
|  | 17  | 18  | 19  | 20  | 21  | 22  | 23  | 24  | 25  | 26  | 27  | 28  | 29  | 30  | 31  | 32  |
| Study Day*   | 120                                       | 127 | 134 | 141 | 148 | 155 | 162 | 169 | 176 | 183 | 190 | 197 | 204 | 211 | 218 | 225 |
| Haemo-QOL-A assessment   |   |     |     |     |     |     |     |     |     | X   |     |     |     |     |     |     |
| EQ-5D-5L   |   |     |     |     |     |     |     |     |     | X   |     |     |     |     |     |     |
| HAL  |   |     |     |     |     |     |     |     |     | X   |     |     |     |     |     |     |
| WPAI+CIQ:HS  |   |     |     |     |     |     |     |     |     | X   |     |     |     |     |     |     |
| PROBE  |   |     |     |     |     |     |     |     |     | X   |     |     |     |     |     |     |
| AAV5 TAb Assay   |   |     |     |     |     |     |     | X   |     |     |     |     |     |     |     | X   |
| AAV5 TI Assay  |   |     |     |     |     |     |     | X   |     |     |     |     |     |     |     | X   |
| PBMC collection (for determination of AAV5 and FVIII specific cellular immunity) |   | X   |     | X   |     | X   |     | X   |     | X   |     | X   |     | X   |     | X   |
| VWF:Ag   |   |     |     |     |     |     |     |     |     | X   |     |     |     |     |     |     |
| Direct Thrombin Activity Test <sup>c</sup>                                       |   |     |     |     |     |     |     |     |     | X   |     |     |     |     |     |     |
| TGA Assay <sup>c</sup>   |   |     |     | X   |     |     |     | X   |     | X   |     |     |     |     |     | X   |

\* Visit windows are  $\pm$  48 hours.

<sup>a</sup> Brief physical examination should be done at all weekly visits except Week 26, where a complete physical examination should be performed. Weight should be recorded at Week 20 and every 4 weeks.

<sup>b</sup> Refer to [Table 9.7.8.2.1](#) for laboratory assessments to be included, and to [Table 9.7.8.3.1](#) for liver function tests. LFTs may be monitored more or less frequently (and in particular when ALT values are  $>1.5x$  ULN) based on discussion between the Medical Monitor and the Investigator and review of subject data, but LFTs will be monitored at least twice weekly during periods when a subject's ALT is  $\geq 3x$  ULN. Subjects with ALT  $> 1.5x$  ULN during the study and either an alternative etiology considered or for further evaluation of the lab abnormality may undergo additional evaluations (eg, imaging studies including MRI or ultrasound, additional blood tests, and/or liver biopsy) at the discretion of the Investigator. Additional testing of FVIII and LFTs during any study week may be performed if: (1) the ALT has increased to above ULN; (2) Increases in ALT values from prior assessment are accompanied by declines in



---

FVIII activity level; or after a discussion between the Medical Monitor and the Investigator based on a review of subject data. If FVIII levels and/or ALT values are stable over the course of several weeks, assessment of FVIII activity and liver enzymes may be adjusted based on discussion between the Medical Monitor and the Investigator.

<sup>c</sup> Includes FVIII activity level (chromogenic FVIII assay and one-stage clot FVIII assay), Bethesda assay (with Nijmegen modification) for hFVIII inhibitor level, coagulation exploratory assay, and hFVIII protein. If a subject has used FVIII within 72 hours of a measurement day, all efforts should be made to obtain FVIII activity measurements when a 72-hour interval without FVIII use is achieved; the 72-hour wash-out period is only intended for subjects who have achieved FVIII  $\geq 5$  IU/dL at 16 weeks after BMN 270 infusion and who have not resumed FVIII replacement therapy. If FVIII levels are elevated or stable over the course of several weeks, assessment of FVIII activity may be adjusted based on discussion between the Medical Monitor and the Investigator. A D-dimer may be considered under circumstances in which FVIII activity levels are above the normal physiological range and/or if there is a concern for a venous thromboembolism.

<sup>d</sup> Collection for each matrix to occur until at least 3 consecutive negative results are obtained.

<sup>e</sup> Blood samples will be collected to evaluate biochemical, molecular, cellular, and genetic/genomic aspects relevant to hemophilia A, coagulation, and/or AAV gene transfer, and to develop assays used for these evaluations. Subjects may choose to opt out of the exploratory genetic/genomic research being done to study or try to discover genes that are not yet known to be associated with hemophilia A. While exploratory samples will be collected at the time points indicated above, testing of these samples (including those for TGA assay, Direct Thrombin Activity test, and any other exploratory assessments) will be performed only as deemed necessary by the Sponsor.

**Table 9.1.4: Schedule of Events – Post-Infusion Follow-Up (Week 33 – Year 5)**

| Assessment  | Year 1 – Weeks* |     |     |     |     |     |     |     |     |     |     |     | Years 2-5*       | Year 2*          | Years 3-5*       | ETV |
|---|-----------------|-----|-----|-----|-----|-----|-----|-----|-----|-----|-----|-----|------------------|------------------|------------------|-----|
|   | 33              | 34  | 35  | 36  | 38  | 40  | 42  | 44  | 46  | 48  | 50  | 52  | Q3M              | Q4W              | Q6W              |     |
| Study Day*  | 232             | 239 | 246 | 253 | 267 | 281 | 295 | 309 | 323 | 337 | 351 | 365 | Q3M              | Q4W              | Q6W              |     |
| Physical examination <sup>a</sup>   | X               | X   | X   | X   | X   | X   | X   | X   | X   | X   | X   | X   | X <sup>a</sup>   |                  |                  | X   |
| Weight <sup>a</sup>   |                 |     |     | X   |     | X   |     | X   |     | X   |     | X   | X <sup>a</sup>   |                  |                  | X   |
| Assessment of Adverse Events and Concomitant Medications (including review of subject diary for bleeding and FVIII use) | X               | X   | X   | X   | X   | X   | X   | X   | X   | X   | X   | X   | X                | X                | X                | X   |
| Vital Signs   | X               | X   | X   | X   | X   | X   | X   | X   | X   | X   | X   | X   | X                |                  |                  | X   |
| Blood chemistry, hematology, and coagulation tests <sup>b</sup>   |                 |     |     | X   |     |     |     | X   |     |     |     | X   | X <sup>b</sup>   |                  |                  | X   |
| Urine Tests <sup>b</sup>  |                 |     |     |     | X   |     |     |     |     |     |     | X   | X <sup>b</sup>   |                  |                  | X   |
| Liver Function Tests <sup>b</sup>   | X               | X   | X   | X   | X   | X   | X   | X   | X   | X   | X   | X   | X                | X                | X                | X   |
| FVIII assays <sup>c</sup>   | X               | X   | X   | X   | X   | X   | X   | X   | X   | X   | X   | X   | X                | X                | X                | X   |
| AAV5 TAb Assay  |                 |     |     | X   |     |     |     |     |     |     |     | X   | X                |                  |                  | X   |
| AAV5 TI Assay   |                 |     |     | X   |     |     |     |     |     |     |     | X   | X                |                  |                  | X   |
| FVIII antibody titer  |                 |     |     | X   |     |     |     | X   |     |     |     | X   | X                |                  |                  | X   |
| Exploratory biomarker assessments <sup>c</sup>  |                 |     |     | X   |     | X   |     | X   |     | X   |     | X   | X                |                  |                  | X   |
| PBMC Collection (for determination of FVIII and Capsid specific cellular immunity)                                      |                 | X   |     | X   |     |     |     | X   |     |     |     | X   | X                |                  |                  | X   |
| VWF:Ag  |                 |     |     |     | X   |     |     |     |     |     |     | X   | X                |                  |                  | X   |
| Direct Thrombin Activity Test <sup>c</sup>  |                 |     |     |     | X   |     |     |     |     |     |     | X   | X                |                  |                  | X   |
| TGA Assay <sup>c</sup>  |                 |     |     | X   |     | X   |     | X   |     | X   |     | X   | X                |                  |                  | X   |
| PCR of vector DNA in blood, saliva, urine, semen, and stools <sup>d</sup>   |                 |     |     | X   |     | X   |     | X   |     | X   |     | X   | (X) <sup>d</sup> | (X) <sup>d</sup> | (X) <sup>d</sup> | X   |



| Assessment             | Year 1 – Weeks* |     |     |     |     |     |     |     |     |     |     |     | Years 2-5*     | Year 2* | Years 3-5* | ETV |
|------------------------|-----------------|-----|-----|-----|-----|-----|-----|-----|-----|-----|-----|-----|----------------|---------|------------|-----|
|                        | 33              | 34  | 35  | 36  | 38  | 40  | 42  | 44  | 46  | 48  | 50  | 52  | Q3M            | Q4W     | Q6W        |     |
| Study Day*             | 232             | 239 | 246 | 253 | 267 | 281 | 295 | 309 | 323 | 337 | 351 | 365 | Q3M            | Q4W     | Q6W        |     |
| Haemo-QOL-A assessment |                 |     |     |     |     |     |     |     |     |     |     | X   | X <sup>f</sup> |         |            | X   |
| EQ-5D-5L               |                 |     |     |     |     |     |     |     |     |     |     | X   | X <sup>f</sup> |         |            | X   |
| HAL                    |                 |     |     |     |     |     |     |     |     |     |     | X   | X <sup>f</sup> |         |            | X   |
| WPAI+CIQ:HS            |                 |     |     |     |     |     |     |     |     |     |     | X   | X <sup>f</sup> |         |            | X   |
| PROBE                  |                 |     |     |     |     |     |     |     |     |     |     | X   | X <sup>f</sup> |         |            | X   |

\* Visit windows are  $\pm$  48 hours through Week 36, then  $\pm$ 1 week until Week 52 and  $\pm$  2 weeks for visits in Years 2-5. For LFT and FVIII testing during Years 2-5, the visit windows are every 4 weeks (+ 2 weeks, or to align with the Q3M visits) during Year 2, and every 6 weeks ( $\pm$ 2 weeks) during Years 3-5. At applicable sites, the Q4W (during Year 2) and Q6W (during Years 3-5) assessments may be conducted by a trained mobile nursing (MN) professional at the subject's home or another suitable location, if the subject has given written informed consent to participate in mobile nursing visits. Q3M visits during Years 2-5 cannot be done by a MN professional and must be done at the study site.

<sup>a</sup> Complete physical examination should be performed at Week 52 and every 52 weeks thereafter; brief physical exam may be performed at other study visits. Weight should be recorded at Week 36 and every 4 weeks through Week 52, then every 6 months during Years 2-5.

<sup>b</sup> Refer to [Table 9.7.8.2.1](#) for laboratory assessments to be included, and to [Table 9.7.8.3.1](#) for liver function tests. LFTs may be monitored more or less frequently (and in particular when ALT values are  $>1.5x$  ULN) based on discussion between the Medical Monitor and the Investigator and review of subject data, but LFTs will be monitored at least twice weekly during periods when a subject's ALT is  $\geq 3x$  ULN. Subjects with ALT  $> 1.5x$  ULN during the study and either an alternative etiology considered or for further evaluation of the lab abnormality may undergo additional evaluations (eg, imaging studies including MRI or ultrasound, additional blood tests, and/or liver biopsy) at the discretion of the Investigator. Additional testing of FVIII and LFTs during any study week may be performed if: (1) the ALT has increased to above ULN or increased by  $> 10$  U/L from prior assessment; (2) Increases in ALT values from prior assessment are accompanied by declines in FVIII activity level; or after a discussion between the Medical Monitor and the Investigator based on a review of subject data. If FVIII levels and/or ALT values are stable over the course of several weeks, assessment of FVIII activity and liver enzymes may be adjusted based on discussion between the Medical Monitor and the Investigator. During Years 2-5 of the Post-Infusion Follow-Up period, urine tests and blood, chemistry, and coagulation tests should be performed every 6 months (starting with Week 78).

<sup>c</sup> Includes FVIII activity level (chromogenic FVIII assay and one-stage clot FVIII assay), Bethesda assay (with Nijmegen modification) for hFVIII inhibitor level, coagulation exploratory assay, and hFVIII protein assay. If a subject has used FVIII within 72 hours of a measurement day, all efforts should be made to obtain FVIII activity measurements when a 72-hour interval without FVIII use is achieved; the 72-hour wash-out period is only intended for subjects who have achieved FVIII  $\geq 5$  IU/dL at 16 weeks after BMN 270 infusion and who have not resumed FVIII replacement therapy. If FVIII levels are elevated or stable over the course of several weeks, assessment of FVIII activity may be adjusted based on discussion between the Medical Monitor and the Investigator. A D-dimer may be considered under circumstances in which FVIII activity levels are above the normal physiological range and/or if there is a





---

concern for a venous thromboembolism. If a subject tests positive in the Bethesda assay (with Nijmegen modification) during Years 3-5, a fresh sample should be collected within 4 weeks of the initial visit that had a positive result.

- <sup>d</sup> Sample testing during Long-Term Follow-Up is not required if at least 3 consecutive samples were negative during the Post-Infusion Follow-Up period. Subjects who have not had 3 consecutive negative semen samples by Week 52 should continue to have PCR testing of semen every 4 weeks (during Year 2) or every 6 weeks (during Years 3-5) until 3 consecutive negative samples are documented (or upon consultation between the Investigator and Medical Monitor).
- <sup>e</sup> Blood samples will be collected to evaluate biochemical, molecular, cellular, and genetic/genomic aspects relevant to hemophilia A, coagulation, and/or AAV gene transfer, and to develop assays used for these evaluations. Subjects may choose to opt out of the exploratory genetic/genomic research being done to study or try to discover genes that are not yet known to be associated with hemophilia A. While exploratory samples will be collected at the time points indicated above, testing of these samples (including those for TGA assay, Direct Thrombin Activity test, and any other exploratory assessments) will be performed only as deemed necessary by the Sponsor.
- <sup>f</sup> PRO assessments during Years 2-5 of Long-Term Follow-up should be performed at every other visit (every 6 months) starting with the Week 78 visit (ie, 26 weeks after the Week 52 visit at the end of Year 1 of the Long-Term Follow-up period).

**Table 9.1.5: Schedule of Events – Therapeutic Corticosteroids for LFT Elevations or Decreased FVIII Activity**

|   | Steroid Treatment Period <sup>b</sup> |        |        |        |        |        |        |                     | Post-Steroid Period <sup>c</sup> |        |        |        |         |
|---|---------------------------------------|--------|--------|--------|--------|--------|--------|---------------------|----------------------------------|--------|--------|--------|---------|
|   | Week 1                                | Week 2 | Week 3 | Week 4 | Week 5 | Week 6 | Week 7 | Week 8 <sup>b</sup> | Week 1                           | Week 2 | Week 3 | Week 4 | Week 13 |
| Therapeutic corticosteroids (dose in mg/day) <sup>a</sup> | 60 mg                                 | 60 mg  | 40 mg  | 40 mg  | 40 mg  | 30 mg  | 20 mg  | 10 mg               |                                  |        |        |        |         |
| FVIII activity testing                                    |                                       |        |        |        |        |        |        |                     | X                                | X      | X      | X      |         |
| Liver function testing                                    |                                       |        |        |        |        |        |        |                     | X                                | X      | X      | X      |         |
| Hepatitis B testing <sup>d</sup>                          |                                       |        |        |        |        | X      |        |                     | X                                |        |        |        | X       |
| HCV Viral Load <sup>d</sup>                               |                                       |        |        |        |        | X      |        |                     | X                                |        |        |        | X       |

<sup>a</sup> Therapeutic oral corticosteroids may be initiated according to the parameters set out in Section 9.4.8.2.

<sup>b</sup> Following initiation or completion of steroid regimen, if a recurrence of ALT values > 1.5x ULN is reported, steroid management decisions will be based on discussions between the Investigator and Medical Monitor. Modification of the steroid regimen may take into consideration possible confounders for the ALT elevation, relationship between increases in ALT and FVIII activity, ALT/FVIII levels post steroid initiation, and adverse events related to steroid dosing. Guidance for tapering oral corticosteroid dosing can be found in Section 9.4.8.2.

<sup>c</sup> After discontinuation of oral corticosteroids, weekly labs for ALT and FVIII levels will be measured once a week for 4 weeks to ensure stability in values. If these assessments are already being done as part of normal study follow-up, they do not need to be duplicated.

<sup>d</sup> Should only be performed in subjects with a history of hepatitis B or hepatitis C prior to study entry.



## 9.2 Discussion of Study Design, Including Choice of Control Group

Study 270-301 is designed to be a Phase 3, single-arm, open-label study in hemophilia A patients with residual FVIII levels  $\leq 1$  IU/dL previously treated with prophylactic exogenous FVIII. Hemophilia A patients who provide written informed consent, meet the entry criteria definition of residual FVIII activity, have well-documented historical data for the previous 12 months concerning exogenous FVIII usage and bleeding episodes, and do not have antibodies to AAV5 will be eligible to enroll in the study.

Approximately 130 subjects will be enrolled at the 6E13 vg/kg BMN 270 dose. Subjects will be followed for 52 weeks post-BMN 270 infusion during which safety and efficacy assessments will be taken. After the final analysis at 52 weeks post-infusion, safety and efficacy will then continue to be assessed long-term for approximately a total of 5 years. During enrollment, the DMC will review available safety and efficacy data on an ongoing basis and may decide to recommend dosing subjects at a different dose level (not to exceed 6E13 vg/kg) based on emerging data from 270-301 and their overall benefit:risk assessment.

Study 270-301 is a self-controlled study. Parameters for each subject will be compared to a pre-treatment assessment of safety (liver function) and efficacy (number of bleeds, use of FVIII replacement therapy).

## 9.3 Selection of Study Population

Approximately 130 adult hemophilia A patients with residual FVIII levels  $\leq 1$  IU/dL may enroll into the study.

Additional criteria for participation in the study are provided in Section 9.3.1 and Section 9.3.2.

### 9.3.1 Inclusion Criteria

Individuals eligible to participate in this study must meet all of the following inclusion criteria:

1. Males  $\geq 18$  years of age with hemophilia A and residual FVIII levels  $\leq 1$  IU/dL as evidenced by medical history, at the time of signing the informed consent.
2. Must have been on prophylactic FVIII replacement therapy for at least 12 months prior to study entry. High-quality, well-documented historical data concerning bleeding episodes and FVIII usage over the previous 12 months must be available.
3. Treated/exposed to FVIII concentrates or cryoprecipitate for a minimum of 150 exposure days (EDs).



4. Willing and able to provide written, signed informed consent after the nature of the study has been explained and prior to any study-related procedures.
5. No previous documented history of a detectable FVIII inhibitor, and results from a Bethesda assay or Bethesda assay with Nijmegen modification of less than 0.6 Bethesda Units (BU) (or less than 1.0 BU for laboratories with a historical lower sensitivity cutoff for inhibitor detection of 1.0 BU) on 2 consecutive occasions at least one week apart within the past 12 months (at least one of which should be tested at the central laboratory).
6. Sexually active participants must agree to use an acceptable method of effective contraception, either double-barrier contraception (ie, condom + diaphragm; or condom or diaphragm + spermicidal gel or foam) or their female partner either using hormonal contraceptives or having an intrauterine device. Participants must agree to contraception use for at least 12 weeks post-infusion; after 12 weeks, subjects may stop contraception use only if they have had 3 consecutive semen samples with no detectable viral vector DNA.
7. Willing to abstain from alcohol consumption for at least the first 52 weeks following BMN 270 infusion.
8. HIV positive patients may be enrolled, only if the patient has a CD4 count > 200/mm<sup>3</sup> and an undetectable viral load (unquantifiable viral load as defined as less than the limit of quantification by the testing laboratory's assay is permitted)

### 9.3.2 Exclusion Criteria

Individuals who meet any of the following exclusion criteria will not be eligible to participate in the study:

1. Detectable pre-existing antibodies to the AAV5 capsid.
2. Any evidence of active infection or any immunosuppressive disorder, except for HIV infection as described in the inclusion criterion above.
3. Significant liver dysfunction with any of the following abnormal laboratory results:
  - ALT (alanine transaminase) or AST >2X ULN;
  - Total bilirubin >2X ULN;
  - Alkaline phosphatase >2X ULN; or
  - INR (international normalized ratio)  $\geq$  1.4.



Subjects whose liver laboratory assessments fall outside of these ranges may undergo repeat testing and, if eligibility criteria are met on retest, may be enrolled after confirmation by the Medical Monitor. In addition, subjects with abnormal laboratory results related to confirmed benign liver conditions are considered eligible for the study notwithstanding their abnormal laboratory results and may be enrolled after discussion with the Medical Monitor.

- Benign liver conditions are those conditions (eg, Gilbert's syndrome) where physiologic hepatic findings can be considered non-serious in nature and do not confer illness or in most instances require treatment. Individuals with such conditions that do not impact laboratory values such as serum transaminases or conjugated bilirubin (eg, Gilbert's syndrome) and enable assessment of potential liver toxicity following BMN 270 infusion may be included in the study following a review by the Medical Monitor.
4. Prior liver biopsy showing significant fibrosis of 3 or 4 as rated on a scale of 0-4 on the Batts-Ludwig (Batts, 1995) or METAVIR (Bedossa, 1996) scoring systems, or an equivalent grade of fibrosis if an alternative scale is used.
  5. Evidence of any bleeding disorder not related to hemophilia A.
  6. Platelet count of  $< 100 \times 10^9/L$ .
  7. Creatinine  $\geq 1.5$  mg/dL.
  8. Liver cirrhosis of any etiology as assessed by liver ultrasound.
  9. Chronic or active hepatitis B as evidenced by positive serology testing (HBsAg, HBsAb, and HBcAb) and confirmatory HBV DNA testing. Refer to the Centers for Disease Control (CDC) table for the interpretation of serological test results in the Laboratory Manual.
  10. Active Hepatitis C as evidenced by detectable HCV RNA or currently on antiviral therapy.
  11. Active malignancy, except non-melanoma skin cancer.
  12. History of hepatic malignancy.
  13. History of arterial or venous thromboembolic events (eg, deep vein thrombosis, non-hemorrhagic stroke, pulmonary embolism, myocardial infarction, arterial embolus), with the exception of catheter-associated thrombosis for which anti-thrombotic treatment is not currently ongoing.
  14. Known inherited or acquired thrombophilia, including conditions associated with increased thromboembolic risk, such as atrial fibrillation.



15. Treatment with any investigational product within 30 days or 5 half-lives of the investigational product prior to the screening period. For subjects who have received a prior investigational product, all ongoing adverse events (AEs) experienced while receiving that investigational product must have resolved prior to screening for this study.
16. Any condition that, in the opinion of the Investigator or Sponsor would prevent the patient from fully complying with the requirements of the study (including possible corticosteroid treatment outlined in the protocol) and/or would impact or interfere with evaluation and interpretation of subject safety or efficacy result.
17. Prior treatment with any vector or gene transfer agent.
18. Major surgery planned in the 52-week period following the infusion with BMN 270.
19. Use of systemic immunosuppressive agents, not including corticosteroids, or live vaccines within 30 days before the BMN 270 infusion.
20. Concurrent enrollment in another clinical study, unless it is an observational (non-interventional) clinical study that does not interfere with the requirements of the current protocol or have the potential to impact the evaluation of efficacy and safety of BMN 270 and with prior consultation with the Medical Monitor.
21. Known allergy or hypersensitivity to BMN 270 investigational product formulation.
22. Unwilling to receive blood or blood products for treatment of an adverse event and/or a bleeding episode.

### **9.3.3 Removal of Subjects from Treatment or Assessment**

Subjects may withdraw their consent to participate in the study at any time without prejudice. The Investigator must withdraw from the study any subject who requests to be withdrawn. Such subjects will always be asked about the reason(s) for withdrawal. The Investigator will discuss with the subject appropriate procedures for withdrawal from the study. The Investigator should ask the subject's consent to perform the procedures listed under the early termination visit. Should a subject withdraw from the study, all efforts will be made to complete and report the observations as thoroughly as possible up to the date of the withdrawal.

A subject's participation in the study may be discontinued at any time at the discretion of BioMarin or of the Investigator and in accordance with his/her clinical judgment. When possible, the tests and evaluations listed for the termination visit should be carried out and every effort will be made to gather follow-up safety data if possible.

BioMarin must be notified of all subject withdrawals as soon as possible. BioMarin also reserves the right to discontinue the study at any time for either clinical or administrative



reasons and to discontinue participation by an individual Investigator or site for poor enrollment or noncompliance.

Reasons for which the Investigator or BioMarin may withdraw a subject from the study include, but are not limited to, the following:

- Subject requires medication or medical procedure prohibited by the protocol
- Subject does not adhere to study requirements specified in the protocol
- Subject was erroneously enrolled into the study or does not meet entry criteria and not yet been dosed with BMN 270; subjects who do not meet entry criteria but who erroneously receive BMN 270 should remain in the study for safety monitoring
- Subject is lost to follow-up

If a subject fails to return for scheduled visits, a documented effort must be made to determine the reason. If the subject cannot be reached by telephone, a certified letter should be sent to the subject requesting contact with the Investigator. This information should be recorded in the study records.

The Investigator or designee must explain to each subject, before enrollment into the study, that for evaluation of study results, the subject's protected health information obtained during the study may be shared with the study Sponsor, regulatory agencies, and IRB/IEC/REB. It is the Investigator's (or designee's) responsibility to obtain written permission to use protected health information per country-specific regulations, such as the Health Insurance Portability and Accountability Act (HIPAA) in the US, from each subject. If permission to use protected health information is withdrawn, it is the Investigator's responsibility to obtain a written request, to ensure that no further data will be collected from the subject and the subject will be removed from the study.

### **9.3.3.1 Study Safety Evaluation Criteria**

If any of the following events occur in a subject in the study who has received BMN 270 infusion, an urgent evaluation by the DMC will be required and further enrollment into the trial will be temporarily put on hold if recommended by the DMC per Section 9.1.

1. Liver dysfunction (criteria do not apply to ALT elevations with an extra-hepatic etiology):
  - ALT >5x ULN, for more than 2 weeks
  - ALT >3x ULN **and** (total bilirubin >2x ULN **or** INR >1.5)
  - ALT >3x ULN with signs and symptoms of liver dysfunction



2. The occurrence of Grade 4 or Grade 5 adverse events assessed as related to study drug (events of liver dysfunction are defined above).
3. The occurrence of an AE of hepatic failure.
4. The detection of high-titer neutralizing antibodies (>5 BU) to hFVIII following BMN 270 infusion in two subjects.
5. The occurrence of any cancer (except non-melanoma skin cancer) at any point after BMN 270 infusion.
6. The occurrence of a thromboembolic event with FVIII activity > 150 IU/dL in one subject.

If any of the following events occurs in a subject in the study who has received BMN 270 infusion, an urgent evaluation by the DMC will be required. Further enrollment into the trial will continue while DMC evaluation is ongoing, unless deemed otherwise by the DMC:

1. The detection of high-titer neutralizing antibodies (>5 BU) to hFVIII following BMN 270 infusion in one subject.
2. Occurrence of a thromboembolic event in one subject.

### **9.3.4 Subject Identification and Replacement of Subjects**

Each subject will be assigned a unique subject identifier. This unique identifier will be on all eCRF pages. In legal jurisdictions where use of initials is not permitted, a substitute identifier will be used.

Subjects who withdraw from the study after receiving BMN 270 will not be replaced.

### **9.3.5 Duration of Subject Participation**

The duration of participation for each subject will be approximately 264 weeks. This includes 4 weeks of screening, 1 day of BMN 270 infusion, 52 weeks of Post-Infusion Follow-Up, and 208 weeks of Long-Term Follow-Up.

## **9.4 Treatments**

### **9.4.1 Treatments Administered**

BioMarin and/or its designee will provide the study site with a supply of IP sufficient for the completion of the study. BioMarin is responsible for shipping study drug to clinical sites.

### **9.4.2 Identity of Investigational Product**

#### **9.4.2.1 Product Characteristics and Labeling**

BMN 270 is a sterile, clear, colorless-to-pale yellow solution for IV infusion and is supplied in a 10 mL Crystal Zenith® (CZ) vial. Each vial contains 8.5 mL (extractable volume 8 mL)





of AAV5-hFVIII-SQ at a concentration of  $2E13$  vector genomes per mL in a pH 7.4 phosphate buffer.

The study drug is labelled according to the particulars approved by the relevant regulatory agencies.

#### **9.4.3 Storage**

At the study site, all IP must be stored under the conditions specified in the Pharmacy Manual in a secure area accessible only to the designated pharmacists and clinical site personnel. All IP must be stored and inventoried and the inventories must be carefully and accurately documented according to applicable state, federal and local regulations, ICH GCP, and study procedures.

#### **9.4.4 Directions for Administration**

On the day of infusion, the subject will come to the infusion site, where a physical examination will be performed by the Investigator or designee. If the subject is found to have an active acute illness at the time of planned infusion, then the infusion should be deferred until the illness has resolved; screening procedures may require repetition if outside the specified window. An IV catheter or butterfly needle will be inserted into a suitable peripheral vein (eg, the median cubital vein) and flushed with saline. FVIII replacement therapy will not be given since venipuncture is a minimally invasive procedure in these individuals under ordinary conditions.

BMN 270 will be prepared and infused as a pure solution over a dose-dependent time. Prepared drug will be kept at room temperature prior to administration. An electric syringe pump will be used to infuse through an in-line, low protein binding 0.22 micron filter. BMN 270 will be infused through the catheter using an appropriate infusion pump at an initial rate of 1 mL/min. The infusion rate should be increased every 30 minutes by 1 mL/min up to a maximum of 4 mL/min, provided that the subject's clinical condition permits such an increase. Of note, the IP has been shown to be stable at room temperature for 7.5 hours following completion of product thaw. Vital signs (pulse, blood pressure, respiration rate and temperature) should be monitored at 15 minute ( $\pm 5$  minutes) intervals throughout the time period of the infusion.

As with any infused biological product, there is a potential risk of acute, systemic hypersensitivity reactions (including anaphylaxis) with BMN 270. Dosing will be administered at a qualified infusion site, with appropriate resuscitation equipment and medication available and easily accessible.



Clinical staff administering BMN 270 should be trained appropriately in recognizing and managing the signs and symptoms associated with potential hypersensitivity, anaphylactic, and anaphylactoid reactions. Additionally, the Investigator should be familiar with Sampson's criteria for defining anaphylaxis (Sampson, 2006; Appendix 1).

Should symptoms of potential hypersensitivity occur, the infusion may be slowed or halted at the Investigator's discretion, with consideration of the subject's clinical condition. If the infusion is halted, it should only be restarted if the Investigator considers it safe and appropriate to do so. Antihistamines, anti-pyretic, and/or corticosteroid administration is permitted prior to restarting an interrupted infusion by an infusion-related reaction. At the restart, the infusion rate may be adjusted (ie, to a slower rate [minimum of 1 mL/min], with the rate increased every 30 minutes by 1 mL/min up to a maximum rate of 4 mL/min, if the subject's clinical condition permits such an increase) with careful monitoring of the subject.

In case of hypersensitivity or adverse drug reaction, safety assessment, including physical examination and vital signs, will be done and additional blood samples will be collected within 1 hour of the hypersensitivity reaction (eg, tryptase, C3, C3a, C4, C5, and C5a, as well as possible additional exploratory testing) and one sample for IgE (and possible additional exploratory testing) between 8-24 hours after the reaction, if possible. In-patient observation can be extended and additional blood samples can be collected if deemed necessary at the discretion of the Investigator and Medical Monitor.

Following completion of the infusion, vital signs will be monitored hourly ( $\pm$  5 minutes). If the vital signs are stable the catheter will be removed 8 hours after the infusion. Hemostasis at the puncture site will be established by applying pressure according to standard protocol for infusing FVIII concentrates. Subjects will remain in the clinic for at least 8 hours to observe for any immediate toxicity of the procedure; in-patient observation can be extended beyond 8 hours if needed per Investigator discretion, or the subject may transfer to a separate facility based on the evaluation and judgment of the Principal Investigator after consultation with the Medical Monitor.

Prior to discharging subjects from the clinic, the Investigator or designee should instruct subjects how to recognize signs and symptoms of potential (delayed) hypersensitivity reactions and anaphylaxis, and to contact a medical practitioner or seek emergency care in case of such an event.

#### **9.4.5 Method of Assigning Subjects to Treatment Groups**

Subjects who meet all eligibility criteria (refer to Section 9.3.1 and Section 9.3.2) may be enrolled into the study. Approval by the Medical Monitor will be required prior to enrollment



of each study subject. Upon their enrollment into the study, subjects will be assigned a unique subject number.

Approximately 130 subjects will be enrolled at 6E13 vg/kg.

#### **9.4.6 Selection of Dose Used in the Study**

Data from an ongoing first in human study (Clinical Study 270-201) indicates that following single escalated doses of BMN 270 (6E12, 2E13, 4E13, 6E13 vg/kg), dose-related increases in FVIII activity were observed, with concurrent improvements in bleeding episodes and exogenous FVIII utilization, particularly at the 4E13 and 6E13 vg/kg dose levels. At all dose levels, BMN 270 is considered to be well-tolerated with mild increases in ALT as the most common adverse event. Please refer to the IB for detailed efficacy and safety data.

In order to further evaluate the dose-response relationship of BMN 270, subjects will be enrolled at a dose of 6E13 vg/kg. This dose is expected to be safe and effective based on clinical experience to date in 270-201. The DMC will review emerging safety and efficacy data and may recommend that a different dose (not to exceed 6E13 vg/kg) be administered. In such a case, up to 130 additional subjects may be enrolled at the new dose.

#### **9.4.7 Blinding**

This is an open-label study.

#### **9.4.8 Prior and Concomitant Medications**

All prescription and over-the-counter medications (including dietary and herbal supplements) taken by a subject for 30 days before Screening will be recorded on the designated eCRF. The Investigator may prescribe additional medications, deemed necessary to provide adequate prophylactic or supportive care, during the study, as long as the prescribed medication is not prohibited by the protocol. In the event of an emergency, any needed medications may be prescribed without prior approval, but the Medical Monitor must be notified of the use of any contraindicated medications immediately thereafter. Any concomitant medications added or discontinued during the study should be recorded on the eCRF. Medications should, whenever possible, not be recorded in the electronic database with a frequency of PRN.

The following medications are prohibited starting 30 days before Screening and through the end of the study, and the Sponsor must be notified if a subject receives any of these during the study:

- Any investigational therapy



- 
- Systemic immunosuppressive agents, except for corticosteroids
  - Emicizumab
  - Fitusiran
  - Concizumab

The following medications should be avoided, starting 30 days prior to and for at least 52 weeks after BMN 270 infusion and minimized throughout the remaining duration of the study.

- Alcohol
- Herbal and natural remedies and dietary supplements
- Medications which may be hepatotoxic

Vaccines should also be avoided during this period, but in particular during the first 26 weeks unless clinically indicated.

The following medications should be avoided during oral corticosteroid therapy:

- Vaccines
- NSAIDs

#### **9.4.8.1 Concomitant Hemophilia Treatments**

Subjects on prophylactic FVIII therapy will discontinue their regular treatment regimen starting 4 weeks after the day of infusion or after FVIII activity has reached at least 5 IU/dL (whichever is earlier) and switch to an “on-demand” schedule. FVIII replacement therapy can always be taken as needed by the subject for treatment of an acute bleeding episode; the subject must carefully record his treatment and bleeding episodes in his diary. Prophylactic FVIII use can be used on a case-by-case basis and in consultation with the Medical Monitor to prevent bleeding in extenuating circumstances (eg, peri-operative).

In addition, information on FVIII usage and bleeding episodes by medical history must be well-documented and available and will be collected from subjects for the 12-month period immediately preceding study enrollment. Further information on the details that should be provided as part of the subject’s well-documented medical and FVIII usage history are provided in the On Site File Binder.

In order to enable rigorous comparisons of pre-study versus on-study FVIII usage and bleeding episodes, the Medical Monitor will review each screened patient’s prior bleed and hemophilia medication logs to determine if they are of "high-quality". Elements that will be

assessed to judge the quality of such historical data may include, but are not limited to, the following:

- Date, type (eg, joint, muscle, other), location of bleeds
- Date, name, dose (calculated in IU/kg), and reason for use (eg, usual prophylaxis, one-time prophylaxis, treatment for bleed, surgery) of hemophilia medications.

#### **9.4.8.2 Therapeutic Glucocorticoid Treatment of Elevated Hepatic Transaminases**

Therapeutic oral corticosteroids (prednisone or converted equivalent) should be initiated when either of the following occurs post-BMN 270 infusion in any subject and after consultation with the Medical Monitor (or their designee):

- $ALT \geq 1.5x$  ULN in 2 consecutive assessments within 72-hours and alternative etiologies have been ruled out, or  $ALT \geq 3x$  ULN in 2 consecutive assessments within 48 hours (refer to [Table 9.7.8.3.2](#))
  - Whenever possible, a confirmatory lab draw for ALT should be performed, along with FVIII activity, prior to initiating oral corticosteroids.
  - Corticosteroids may be delayed if elevations in ALT are clearly not related to BMN 270 (eg, elevated in ALT with concurrent increase in CPK due to intensive exercise)

In addition, if FVIII activity drops  $> 50\%$  at any time post-BMN 270 infusion, a course of therapeutic oral corticosteroids should be considered upon consultation between the Investigator and the Medical Monitor.

The prescribed regimen for therapeutic oral corticosteroids is detailed in [Table 9.1.5](#). Changes to the corticosteroid regimen should be made as follows:

**Table 9.4.8.2.1: Adjustments to Corticosteroid Regimen**

|   |   |  |
|---|---|--|
| <b>Tapering<br/>Corticosteroid<br/>Dose</b>   | Subject has been receiving oral corticosteroids <3 weeks  | Corticosteroids may be discontinued <b>if</b> : <ul style="list-style-type: none"> <li>• ALT &lt;1.5 ULN; and</li> <li>• FVIII levels &gt; 20 IU/dL and within 10% of the pre-decline FVIII levels; and</li> <li>• There is no concern for adrenal insufficiency post-withdrawal</li> </ul>            |
|   | Subject has been receiving oral corticosteroids ≥3 weeks  | Corticosteroids may be tapered by 10 mg weekly <b>if</b> : <ul style="list-style-type: none"> <li>• ALT &lt;1.5 ULN; and</li> <li>• FVIII levels &gt; 20 IU/dL and within 10% of the pre-decline FVIII levels; and</li> <li>• There is no concern for adrenal insufficiency post-withdrawal</li> </ul> |
| <b>Increasing<br/>Corticosteroid<br/>Dose</b> | If ALT level is increasing or FVIII level is decreasing while on oral corticosteroids, any increases in oral corticosteroid dosing should be made only upon consultation with the Medical Monitor |  |

After discontinuation of oral corticosteroids, labs for ALT and FVIII levels will be measured once a week for 4 weeks to ensure stability in values.

Following initiation or completion of therapeutic oral corticosteroids, if ALT elevation ≥1.5x ULN is reported, corticosteroid management decisions will be based on discussions between the Investigator and Medical Monitor. Modification of the corticosteroid regimen may take into consideration possible confounders for the ALT elevation and impact on FVIII expression.

Management and monitoring of reactions to corticosteroids should be determined by the Investigator's clinical judgment in consultation with the Sponsor's Medical Monitor. This includes the contraindicated use of NSAIDs during corticosteroid treatment and specific monitoring not already covered by the schedule of events. The use of COX-2 inhibitors, while not contraindicated during corticosteroid treatment, should be limited, if possible. Practical management to prevent complications related to oral corticosteroid therapy may be undertaken at the discretion of the Investigator (eg, evaluation of glucose intolerance, hyperlipidemia etc.). Hepatitis B status and HCV viral load will be rechecked 6 weeks after the start of oral corticosteroid treatment and then 1 week and 13 weeks after the completion of oral corticosteroid treatment in subjects with a history of hepatitis B or hepatitis C. All adverse events (including any adverse events suspected to be caused by or related to corticosteroid use) should be reported as outlined in Section 10 of the protocol.



### **9.4.8.3 Monitoring of HIV-Positive Subjects**

HIV-positive subjects may be enrolled in 270-301 if the subject has a CD4 count  $> 200/\text{mm}^3$  and an undetectable viral load (unquantifiable viral load as defined as less than the limit of quantification by the testing laboratory's assay is permitted).

Subjects should continue anti-retroviral therapy (ART) as prescribed and follow routine monitoring of CD4 count and viral load ([US Dept Health Human Services, 2014](#)). No alterations in the monitoring are indicated for enrolled immunocompetent HIV-positive subjects who receive corticosteroids as part of their enrollment in 270-301.

### **9.4.9 Treatment Compliance**

Study drug will be administered to subjects at the study site and/or the dosing facility by a qualified health care professional. The quantity dispensed, returned, used, lost, etc. must be recorded on a dispensing log. Sites will be instructed to return or destroy all used and unused study drug containers.

## **9.5 Investigational Product Accountability**

The Investigator or designee is responsible for maintaining accurate records (including dates and quantities) of IP(s) received and IP lost or accidentally or deliberately destroyed. The Investigator or designee must retain all unused or expired study supplies until the study monitor (on-site CRA) has confirmed the accountability data, if allowed by local SOPs.

### **9.5.1 Return and Disposition of Clinical Supplies**

Unused study drug must be kept in a secure location for accountability and reconciliation by the study monitor. The Investigator or designee must provide an explanation for any destroyed or missing study drug or study materials (or must be referenced in their institution SOPs).

Unused study drug may be destroyed on site, per the site's standard operating procedures, but only after BioMarin has granted approval for drug destruction. The monitor must account for all study drug in a formal reconciliation process prior to study drug destruction. All study drug destroyed on site must be documented. Documentation must be provided to BioMarin or designee and retained in the Investigator study files. If a site is unable to destroy study drug appropriately, the site can return unused study drug to BioMarin upon request. The return of study drug or study drug materials must be accounted for on a study drug return form provided by BioMarin.





All study drug and related materials should be stored, inventoried, reconciled, and destroyed or returned according to applicable state and federal regulations and study procedures. For additional information, please refer to the Pharmacy Manual.

## **9.6 Dietary or Other Protocol Restrictions**

There are no dietary or other protocol restrictions for this study. Alcohol should be avoided for the first 52 weeks of the study, and particularly within 48 hours prior to lab work.

Subjects should be advised to abstain from any blood or sperm donation after BMN 270 infusion, until there is no further evidence of vector shedding.

## **9.7 Safety and Efficacy Variables**

### **9.7.1 Safety and Efficacy Measurements Assessed**

The Schedule of Events ([Table 9.1.1](#) through [Table 9.1.4](#)) describes the timing of required evaluations.

### **9.7.2 Primary Efficacy Variables**

#### **9.7.2.1 FVIII Activity**

The primary efficacy variable is change of the hFVIII activity, as measured by one-stage clotting assay, during Weeks 49-52 post-BMN 270 infusion from baseline. Each subject's hFVIII activity during Weeks 49-52 is defined as the median of the values obtained during this 4-week window. Values for FVIII activity will be excluded if obtained within 72 hours since the last infusion of exogenous FVIII protein concentrates.

If a subject has used FVIII within 72 hours of a measurement day, all efforts should be made to obtain FVIII activity measurements when a 72-hour interval without FVIII use is achieved; The 72-hour wash-out period is only intended for subjects who have achieved  $FVIII \geq 5$  IU/dL at 16 weeks after BMN 270 infusion and who have not resumed FVIII replacement therapy.

In the event of an FVIII activity level decline during the study:

- If FVIII activity has declined at least 20% from the peak but less than 35% and has declined for at least 2 consecutive assessments, FVIII activity and LFTs should be repeated every 7 days until FVIII activity is stable or increasing
- If FVIII activity has declined >35% from the peak and has declined for at least 2 consecutive assessments, FVIII activity and LFTs should be repeated every 72 hours until FVIII activity is stable or increasing





In subjects who show an initial response to BMN 270 but who later have FVIII activity decline to  $< 5$  IU/dL, the investigator and Medical Monitor will review the subject's FVIII activity level trends (not specific FVIII activity levels) and discuss whether to resume prior FVIII prophylaxis. In addition, the investigator will notify the subject of his FVIII activity levels and will discuss with the subject the risk of bleeding and when (and if) prior FVIII prophylaxis will be resumed.

Note that fluctuations in FVIII activity are common, and if no clear trend indicating a decline in FVIII activity is observed, then this additional testing may be deferred (upon consultation between the Investigator and the Medical Monitor) until either a more clear trend of decline has been demonstrated or until the FVIII activity levels stabilize or increase.

Details on collecting FVIII activity samples are included in the Laboratory Manual.

### **9.7.3 Secondary Efficacy Variables**

#### **9.7.3.1 Factor VIII Replacement Therapy/Bleeding Episodes**

Secondary efficacy variables are:

- Change of the annualized utilization (IU/kg) of exogenous FVIII replacement therapy during Week 5 to Week 52 post BMN 270 infusion from the baseline utilization of exogenous FVIII replacement therapy.
- Change in the annualized number of bleeding episodes requiring exogenous FVIII replacement treatment during Week 5 to Week 52 of the study post BMN 270 infusion from the baseline ABR.

Subjects must have high quality documented historical data available concerning previous bleeding episodes and exogenous FVIII usage over the previous 12 months in order to be eligible to enroll in the study. During the study, subjects will be asked at each study visit to report the use of factor replacement therapy and the number of bleeding episodes since the previous visit. This information will be captured on the subject's diary or other subject records.

Subjects are strongly encouraged to immediately consult Investigator for guidance regarding exogenous FVIII administration for suspected bleeds or bleeding episodes within the first 30 days post BMN 270 infusion.



## 9.7.4 Tertiary Efficacy Variables

### 9.7.4.1 Patient-Reported Outcomes (PRO)

The Haemo-QoL-A questionnaire is a validated hemophilia-specific health-related quality of life questionnaire for adults (Rentz, 2008). It consists of 41 questions covering six domains (Physical Functioning, Role Functioning, Worry, Consequences of Bleeding, Emotional Impact and Treatment Concerns). Items are answered on a 6-point Likert-type scale, ranging from 0 (None of the time) to 5 (All of the time). Higher scores mean better health-related quality of life or less impairment for a particular subscale (Haemo-QoL Study Group, 2017). Details regarding the Haemo-QoL-A assessment will be included in the On Site File Binder.

The EQ-5D-5L instrument is a self-reported questionnaire designed to measure general health status (The EuroQol Group, 1990) (Brooks, 1996). The EQ-5D-5L is composed of 2-parts: a descriptive system that assesses 5 levels of perceived problems (mobility, self-care, usual activities, pain/discomfort, and anxiety/depression) in 5 dimensions and the EQ visual analogue scale (EQ VAS) assessment for overall health. A sample copy of the EQ-5D-5L and additional information are provided in the On Site File Binder.

The Haemophilia Activities List (HAL) measures the impact of hemophilia on self-perceived functional abilities in adults (Van Genderen, 2006). The instrument consists of multiple domains including lying/sitting/kneeling/standing, leg and arm function, use of transportation, self-care, household tasks, and leisure activities where subjects are asked to rate their level of difficulty with activities of daily living on a 6-point Likert-type scale from 1 (Impossible) to 6 (Never). For some items, subjects are given the choice to answer 'Not applicable'. A sample copy of the HAL and additional information are provided in the On Site File Binder.

The Work Productivity and Activity Impairment plus Classroom Impairment Questions: Hemophilia Specific (WPAI+CIQ:HS) instrument is designed to measure the effect of disease symptom severity on work productivity and classroom productivity (if applicable) (Recht, 2014). The WPAI+CIQ:HS questionnaire yields scores related to work/classroom absenteeism, reduced on-the-job effectiveness, overall work/classroom impairment, and activity impairment. WPAI+CIQ:HS outcomes are expressed as impairment percentages, with higher numbers indicating greater impairment and less productivity (Reilly, 2002). A sample copy of the WPAI+CIQ:HS and additional information are provided in the On Site File Binder.

The Patient Reported Outcomes, Burdens, and Experiences (PROBE) questionnaire is designed to investigate and directly probe patient perspectives on outcomes they deem



relevant to their life and care. PROBE aims to develop a new global tool to enhance the direct patient-voice in health care decision-making (Chai-Adisaksopha, 2017). A sample copy of the PROBE questionnaire and additional information are provided in the On Site File Binder.

### **9.7.5 Immunogenicity**

Immunogenicity assays will be performed on plasma and PBMCs. The assays will include detection of anti-AAV5 capsid and anti-FVIII total antibodies, as well as determination of neutralizing antibodies against FVIII (FVIII inhibitors) and against the AAV5 capsid (Transduction Inhibitors, TI). FVIII Inhibitors will be assessed using the Bethesda assay with Nijmegen modification. Any abnormality of the liver parameters will lead to a retrospective immunogenicity assessment to evaluate FVIII- and capsid-specific cellular immunogenicity. FVIII- and capsid-specific cellular immunity will be assessed by stimulated cytokine secretion using an ELISpot assay performed on collected PBMCs.

### **9.7.6 Pharmacodynamics**

The FVIII protein concentration and activity level as measured by a validated immunoassay and by a validated FVIII activity assay, respectively, will be used for plasma profiles; FVIII protein and activity will be used to determine PD parameters.

### **9.7.7 Exploratory Assessments**

Blood samples will be collected from subjects at the time points indicated in [Table 9.1.1](#), [Table 9.1.2](#), [Table 9.1.3](#), and [Table 9.1.4](#) to evaluate biochemical, molecular, cellular, ABO blood typing, and genetic/genomic aspects relevant to hemophilia A, coagulation, and/or AAV gene transfer, and to develop assays used for these evaluations. Subjects may choose to opt out of the exploratory genetic/genomic research being done to study or try to discover genes that are not yet known to be associated with hemophilia A.

All biomarker samples collected in this study may be used for exploratory biomarker research, including evaluation of additional biomarkers not specifically listed in the protocol. In addition, samples collected for other purposes in this study may be used for exploratory research once testing for the primary purpose has been completed.

### **9.7.8 Safety Variables**

Safety in this study will be determined from evaluation of AEs, clinical laboratory assessments with a particular attention to the liver function, vital signs assessments, physical examinations, and immunogenicity.



### **9.7.8.1 Adverse Events**

The determination, evaluation and reporting of AEs will be performed as outlined in Section 10.

### **9.7.8.2 Clinical Laboratory Assessments**

The scheduled clinical laboratory tests are listed in [Table 9.7.8.2.1](#). Refer to the On Site File Binder for instructions on obtaining and shipping samples.

Any abnormal test results determined to be clinically significant by the Investigator should be repeated (at the Investigator's discretion) until: (1) the cause of the abnormality is determined; (2) the value returns to baseline or to within normal limits; or (3) the Investigator determines that the abnormal value is no longer clinically significant.

All abnormal clinical laboratory results should be initialed and dated by an Investigator, along with a comment regarding whether or not the result is clinically significant. Each clinically significant laboratory result should be recorded as an adverse event.

The diagnosis, if known, associated with abnormalities in clinical laboratory tests that are considered clinically significant by the Investigator will be recorded on the AE eCRF.

**Table 9.7.8.2.1: Clinical Laboratory Tests**

| <b>Blood Chemistry</b> | <b>Hematology</b>         | <b>Urine Tests</b> | <b>Coagulation Screen including:</b> |
|------------------------|---------------------------|--------------------|--------------------------------------|
| Albumin                | Hemoglobin                | Appearance         | APTT                                 |
| BUN                    | Hematocrit                | Color              | PT/INR                               |
| Calcium                | WBC count                 | pH                 | TT                                   |
| Chloride               | RBC count                 | Specific gravity   |                                      |
| Total cholesterol      | Platelet count            | Ketones            |                                      |
| CPK                    | Differential cell count   | Protein            |                                      |
| Creatinine             | RBC indices (MCV and MCH) | Glucose            |                                      |
| CRP                    |                           | Bilirubin          |                                      |
| Glucose                |                           | Nitrite            |                                      |
| Phosphorus             |                           | Urobilinogen       |                                      |
| Potassium              |                           | Hemoglobin         |                                      |
| Total protein          |                           |                    |                                      |
| Sodium                 |                           |                    |                                      |
| Uric Acid              |                           |                    |                                      |

BUN, blood urea nitrogen; CPK, creatinine phosphokinase; CRP, C-reactive protein; PT, prothrombin time; APTT, activated partial thromboplastin time; RBC, red blood cell; WBC, white blood cell; TT, thrombin time; INR, international normalized ratio; MCV, mean corpuscular volume; MCH, mean corpuscular hemoglobin.

In addition to scheduled clinical laboratory assessments, a fasting blood lipid panel (including triglycerides, total cholesterol, HDL cholesterol, and LDL cholesterol) will be assessed at the BMN 270 infusion visit. Subjects will fast for at least 8 hours prior to pre-infusion laboratory sampling on the day of the infusion visit.

In case of hypersensitivity or adverse drug reaction, safety assessment, including physical examination and vital signs, will be done and additional blood samples will be collected within 1 hour of the hypersensitivity reaction (eg, tryptase, C3, C3a, C4, C5, and C5a, as well as possible additional exploratory testing) and one sample for IgE (and possible additional exploratory testing) between 8-24 hours after the reaction.

During Years 2-5, at applicable sites, certain study assessments may be performed by a mobile nursing (MN) professional at the patient's home or another suitable location, such as their school or office, to improve access and convenience for patients participating in the study. The Sponsor may select a healthcare company that will be responsible for providing MN services for participating sites (the MN vendor). The MN vendor is responsible for

ensuring that all MN professionals are licensed, qualified, and in good standing, as per applicable regulations, and that appropriate background checks have been performed. If the investigator at a participating site determines that MN services are appropriate for a patient and the patient gives written informed consent to participate in MN visits, the MN network will communicate with the patient and the patient's site. MN visits will be allowed for the Q4W (during Year 2) and Q6W (during Years 3-5) visits; the Q3M visits during Years 2-5 will not be performed by an MN professional but will be done at the study site.

### 9.7.8.3 Liver Function and Hepatitis Testing

Subjects will be screened for evidence of previous or active hepatitis B or hepatitis C infection at Screening; hepatitis B screening should include HBsAg, HBsAb, and HBcAb. Subjects with documented results showing an absence of active hepatitis B or hepatitis C infection (as measured by positive surface antigen for hepatitis B or positive RNA testing for hepatitis C) 30 days prior to providing signed informed consent do not need to repeat those tests during the screening period.

Evidence of ongoing hepatitis B or hepatitis C infection is exclusionary. Subjects with a history of hepatitis B or hepatitis C infection prior to study entry will be tested for hepatitis B and hepatitis C reactivation at Week 16.

Subjects with a previous history of hepatitis B or hepatitis C who receive therapeutic oral corticosteroids prior to Week 16 do not need to complete the Week 16 reactivation assessment; instead, they will be tested for hepatitis B and hepatitis C reactivation at the time points listed in [Table 9.1.5](#).

A liver ultrasound and liver function testing during Screening will identify any significant hepatic dysfunction.

Liver function tests will be monitored on a regular basis; at each time point, the following LFTs should be assessed:

**Table 9.7.8.3.1: Liver Function Tests**

| Liver Function Tests |                  |                 |     |
|----------------------|------------------|-----------------|-----|
| Alkaline Phosphatase | AST (SGOT)       | Total Bilirubin | LDH |
| ALT (SGPT)           | Direct Bilirubin | GGT             |     |

ALT, alanine aminotransferase; AST, aspartate aminotransferase; GGT, gamma-glutamyltransferase; LDH, lactate dehydrogenase; SGOT, serum glutamic-oxaloacetic transaminase; SGPT, serum glutamic-pyruvic transaminase



Elevated ALT levels (above the upper limit of normal range) should be evaluated according to the following plan:

**Table 9.7.8.3.2: Evaluation of ALT Elevations**

| ALT Level               | Work-Up   |
|-------------------------|---|
| Above ULN and <1.5x ULN | <ul style="list-style-type: none"> <li>• Continue to monitor LFTs and FVIII per protocol (repeat within 7 days if next protocol scheduled visit is &gt;7 days from the time of the reported ALT elevation)</li> <li>• Consider evaluation to rule out alternative etiology (eg, concomitant medications, viral or autoimmune hepatitis, alcohol use, recreational drug use, special diets, strenuous exercise, prior and/or concurrent illnesses, exposure to environmental and/or industrial chemicals, etc.) (refer to <a href="#">Table 9.7.8.3.3</a>)</li> </ul>  |
| 1.5 - <3x ULN           | <ul style="list-style-type: none"> <li>• Repeat LFTs and FVIII within 72 hours</li> <li>• Continue to monitor LFTs weekly until ALT is stable or improving</li> <li>• Evaluate and rule out alternative etiologies (as above)</li> <li>• Consult with Medical Monitor</li> <li>• If ALT is <math>\geq 1.5x</math> ULN in 2 consecutive assessments within 72 hours and alternative etiologies have been ruled out, start oral corticosteroids (refer to <a href="#">Section 9.4.8.2</a>)</li> </ul>   |
| $\geq 3x$ ULN           | <ul style="list-style-type: none"> <li>• Consult with Medical Monitor</li> <li>• Evaluate and rule out alternative etiologies (as above)</li> <li>• Repeat LFTs and FVIII within 48 hours, and continue with monitoring of LFTs at least twice weekly for as long as the subject's ALT remains <math>\geq 3x</math> ULN</li> <li>• If <math>\geq 3x</math> ULN in 2 consecutive assessments within 48 hours, start oral corticosteroids (refer to <a href="#">Section 9.4.8.2</a>)</li> <li>• Obtain other possibly relevant laboratory evaluations (albumin, PT/INR, CRP, etc.)</li> <li>• Obtain complete blood count with differential to assess for eosinophilia</li> <li>• Obtain PBMC to evaluate potential immune response (prior to starting oral corticosteroids)</li> <li>• If no improvement in 14 days, consider gastroenterology and/or hepatology consult, abdominal workup, imaging (including MRI or ultrasound), and/or liver biopsy as appropriate</li> </ul> |





When ruling out alternative viral or autoimmune hepatitis as part of the elevated ALT workup, the following tests should be performed:

**Table 9.7.8.3.3: Viral and Autoimmune Hepatitis Testing**

| <b>Viral Hepatitis Workup Testing</b> | <b>Autoimmune Hepatitis Workup Testing</b> |
|---------------------------------------|--|
| Hepatitis A                           | Smooth muscle antibody                     |
| Hepatitis B                           | Mitochondrial antibody                     |
| Hepatitis C                           | Liver/kidney microsomal antibodies         |
| Cytomegalovirus (CMV)                 | Antinuclear antibody (ANA) HEP-2           |
| Epstein-Barr virus (EBV)              |  |
| Herpes simplex virus (HSV) 1 & 2      |  |

#### **9.7.8.4 HIV Testing**

HIV testing will be performed at Screening. Subjects with documented negative results within the last 30 days prior to screening do not need to be retested.

#### **9.7.8.5 Vital Signs, Physical Examinations and Other Observations Related to Safety**

Vital signs will include seated systolic and diastolic blood pressure, heart rate, respiration rate, and temperature. Any clinically significant change in vital signs will be recorded as an AE.

Systolic blood pressure, diastolic blood pressure, heart rate, respiration rate, and temperature will be assessed at Screening, Baseline, and at the beginning of each visit during the Post-Infusion Follow-Up and Long-Term Follow-Up periods. On the day of the BMN 270 Infusion, vital signs will be monitored prior to infusion, during the infusion every 15 minutes ( $\pm 5$  minutes), following the infusion hourly ( $\pm 5$  minutes) for at least 8 hours during the subject's stay in the clinic. Any abnormal vital sign assessments should be repeated, and both values should be recorded in the eCRF.

A complete physical examination is necessary during Screening/Baseline, at Week 26 and 52 and every 52 weeks thereafter; at other visits, brief physical examinations may be performed at the discretion of the Investigator based on the subject's clinical condition. Particular attention should be given to signs of bleeding, as well as assessing possible hemarthroses.

A complete physical examination will include general appearance (head, eyes, ears, nose, and throat), cardiovascular, dermatologic, lymphatic, respiratory, gastrointestinal, genitourinary, musculoskeletal, and neurologic systems.





A brief physical examination will include general appearance, cardiovascular, dermatologic, respiratory, gastrointestinal, musculoskeletal, and neurologic assessments.

Height will be recorded at Screening only. Weight will be recorded at Screening and then every 4 weeks thereafter through Week 52, and every 6 months during Years 2-5.

#### **9.7.8.6 Vector Shedding**

During the Post-Infusion Follow-Up period, subjects will undergo testing of various bodily samples to look for evidence of vector shedding for possible viral transmission. Bodily fluids will be tested by polymerase chain reaction (PCR). Fluids tested will include:

- Blood
- Saliva
- Semen
- Urine
- Stool

Vector shedding will also be extensively studied in the present clinical trial, at the time points indicated in [Table 9.1.1](#), [Table 9.1.2](#), [Table 9.1.3](#), and [Table 9.1.4](#). Testing will continue until at least 3 consecutive negative results are obtained. Testing of semen will continue at least through Week 12, even if 3 consecutive negative results have been recorded in that compartment prior to that time point. Subjects who have not had 3 consecutive negative semen samples by Week 52 should continue to have PCR testing in semen every 4 weeks (during Year 2) and every 6 weeks (during Years 3-5) until 3 consecutive negative samples are documented (or upon consultation between the Investigator and Medical Monitor).

Samples may be fractionated prior to shedding analysis in order to better characterize the presence, structure, and location of vector DNA and/or vector capsid within each matrix. If needed, the fractionation may be performed with samples collected specifically for shedding analysis (saliva, blood, semen, urine, feces). Alternatively, the vector DNA characterization during shedding analysis may utilize already fractionated exploratory samples obtained from the above biofluids, such as exploratory plasma samples, exploratory PBMC samples, and red blood cells recovered during PBMC/plasma isolations.

Fractionation of semen to collect purified sperm separately from non-sperm cells may be performed in parallel at any visit where semen samples are collected. The shedding analysis of a fractionated semen sample will only be performed if vector DNA was detected in the whole semen sample for the same visit. Fractionation of semen during shedding analysis



---

may be stopped if purified sperm tested positive for vector DNA on at least three visits, or if purified sperm tested negative for vector DNA on at least three consecutive visits.

Contraception use may need to be extended beyond 26 weeks in individual subjects based on observed vector shedding in semen. After 26 weeks, subjects may stop contraception use only if they have had 3 consecutive negative semen samples.

Details for sample collection and storage are provided in the Laboratory Manual.



## 10 REPORTING ADVERSE EVENTS

### 10.1 Safety Parameters and Definitions

Safety assessments will consist of monitoring and recording protocol-defined AEs and SAEs; measurement of protocol-specified hematology, clinical chemistry, and urinalysis variables; measurement of protocol-specified vital signs; and other protocol-defined events of special interest that are deemed critical to the safety evaluation of the study drug.

#### 10.1.1 Adverse Events

For this protocol, an adverse event (AE) is any untoward medical occurrence in a subject, temporally associated with the use of study intervention, whether or not considered related to the study intervention.

An AE can therefore be any unfavorable and unintended sign (including an abnormal laboratory finding), symptom, or disease (new or exacerbated) temporally associated with the use of study intervention.

Events meeting the AE definition include:

- Exacerbation of a chronic or intermittent pre-existing condition including either an increase in frequency and/or intensity of the condition.
- New conditions detected or diagnosed after study intervention administration even though it may have been present before the start of the study.
- Signs, symptoms, or the clinical sequelae of a suspected drug-drug interaction.

Events not meeting the AE definition include:

- Any clinically significant abnormal laboratory findings or other abnormal safety assessments which are associated with the underlying disease, unless judged by the investigator to be more severe than expected for the subject's condition.
- The disease/disorder being studied or expected progression, signs, or symptoms of the disease/disorder being studied, unless more severe than expected for the subject's condition.
- Medical or surgical procedure (eg, endoscopy, appendectomy): the condition that leads to the procedure is the AE.
- Situations in which an untoward medical occurrence did not occur (social and/or convenience admission to a hospital).
- Anticipated day-to-day fluctuations of pre-existing disease(s) or condition(s) present or detected at the start of the study that do not worsen.



### 10.1.1.1 Bleeding and Suspected Bleeding Events

All bleeding events and suspected bleeding events, regardless of the need for exogenous FVIII therapy as treatment, should be captured in subject diaries and recorded on the designated bleeding eCRF. Bleeding events and suspected bleeding events should not be reported as adverse events, with the following exception:

- All bleeding events and suspected bleeding events which meet one or more of the criteria for being serious (refer to Section 10.2) should be reported as serious adverse events (whether or not they are bleeding events that are normal sequelae of hemophilia, and whether or not they required exogenous FVIII as treatment).

### 10.2 Serious Adverse Events

A serious adverse event (SAE) is any untoward medical occurrence that, at any dose:

- Results in death
- Is life-threatening

*Note: Life-threatening refers to an event in which the subject was at risk of death at the time of the event. It does not refer to an event, which hypothetically might have caused death, if it were more severe.*

- Requires inpatient hospitalization or prolongation of existing hospitalization

Note: In general, hospitalization signifies that the subject has been detained (usually involving at least an overnight stay) at the hospital or emergency ward for observation and/or treatment that would not have been appropriate in the physician's office or outpatient setting. If the investigational product preparation, infusion, and post-infusion observation period require transfer to an inpatient setting for completion, in the absence of an AE, this will not be considered an SAE.

Complications that occur during hospitalization are AEs. If a complication prolongs hospitalization, the event is serious.

Hospitalization for elective treatment of a pre-existing condition that did not worsen from baseline is not considered an AE.

- Results in persistent or significant disability or incapacity



- Is a congenital anomaly or birth defect in the child or fetus of a subject exposed to IP prior to conception or during pregnancy
- Is an important medical event or reaction – that, based on medical judgment, may jeopardize the subject or require medical/surgical intervention to prevent one of the other outcomes listed above (eg, anaphylaxis)

### **10.2.1 Events of Special Interest (EOSI)**

The following EOSI need to be reported to the Sponsor within 24 hours of site awareness, irrespective of seriousness, severity or causality:

- Elevation of ALT > 1.5x ULN, regardless of whether that elevation triggers an initiation or modification of oral corticosteroid treatment
- Thromboembolic event
- Systemic hypersensitivity, anaphylactic, or anaphylactoid reactions (refer to Appendix 1)

## **10.3 Methods and Timing for Capturing and Assessing Safety Parameters**

### **10.3.1 Adverse Event Reporting Period**

The study AE reporting period is as follows:

- After informed consent but prior to initiation of study drug, only SAEs associated with any protocol-imposed interventions will be collected. AEs occurring during this time period should be recorded on the Medical History eCRF.
- After informed consent is obtained and following infusion of study drug, the reporting period for all non-serious AEs and SAEs begins and continues for approximately 5 years or until study discontinuation/termination, whichever is longer.

The criteria for determining, and the reporting of SAEs is provided in Section [10.2](#).

### **10.3.2 Eliciting Adverse Events**

Care will be taken not to introduce bias when detecting AEs and/or SAEs. Open-ended and non-leading verbal questioning of the subject is the preferred method to inquire about AE occurrences. The Investigator will record all relevant AE/SAE/EOSI information in the subject's medical record and AE Case Report Form (eCRF).

### **10.3.3 Assessment of Seriousness, Severity, and Causality**

The Investigator responsible for the care of the subject or medically qualified designee will assess AEs for severity, relationship to study drug, and seriousness (refer to Section [10.2](#) for SAE definitions). These assessments must be made by a study clinician with the training and



authority to make a diagnosis (eg, MD/DO, physician’s assistant, nurse practitioner, or DDS).

### 10.3.3.1 Seriousness

The Investigator will assess if an AE should be classified as “serious” based on the seriousness criteria enumerated in Section 10.2. Seriousness serves as a guide for defining regulatory reporting obligations.

### 10.3.3.2 Severity

Severity (as in mild, moderate, or severe headache) is not equivalent to seriousness, which is based on subject/event outcome or action criteria usually associated with events that pose a threat to a subject’s life or functioning. The Investigator will determine the severity of each AE, SAE and EOSI using the NCI CTCAE v4.03. Adverse events that do not have a corresponding CTCAE term will be assessed according to the general guidelines for grading used in the CTCAE v4.03 as stated in Table 10.3.3.2.1.

**Table 10.3.3.2.1: Adverse Event Grading (Severity) Scale**

| Grade | Description  |   |
|-------|--|---|
| 1     | Mild: asymptomatic or mild symptoms; clinical or diagnostic observations only; intervention not indicated  |   |
| 2     | Moderate: minimal, local or noninvasive intervention indicated; limiting age-appropriate instrumental activities of daily living (ADL) <sup>a</sup>                                |   |
| 3     | Severe or medically significant but not immediately life-threatening; hospitalization or prolongation of hospitalization indicated; disabling; limiting self-care ADL <sup>b</sup> |   |
| 4     | Life threatening consequences; urgent intervention indicated   | Grade 4 and 5 AEs should always be reported as SAEs |
| 5     | Death related to AE  |   |

<sup>a</sup> Instrumental ADL refer to the following examples: preparing meals, shopping for groceries or clothes, using the telephone, managing money.

<sup>b</sup> Self-care ADL refer to the following examples: bathing, dressing and undressing, feeding oneself, using the toilet, taking medications, not bedridden.

### 10.3.3.3 Causality

The Investigator will determine the relationship of an AE to the study drug and will record it on the source documents and AE eCRF. To ensure consistency of causality assessments, Investigators should apply the guidance in Table 10.3.3.3.1.

**Table 10.3.3.3.1: Causality Attribution Guidance**

| <b>Relationship</b> | <b>Description</b>   |
|---------------------|--|
| Not Related         | <ul style="list-style-type: none"> <li>• Exposure to the IP has not occurred</li> </ul> <p style="text-align: center;"><b>OR</b></p> <ul style="list-style-type: none"> <li>• The administration of the IP and the occurrence of the AE are not reasonably related in time</li> </ul> <p style="text-align: center;"><b>OR</b></p> <ul style="list-style-type: none"> <li>• The AE is considered likely to be related to an etiology other than the use of the IP; that is, there are no facts, evidence, or arguments to suggest a causal relationship to the IP.</li> </ul>  |
| Related             | <ul style="list-style-type: none"> <li>• The administration of the IP and the occurrence of the AE are reasonably related in time</li> </ul> <p style="text-align: center;"><b><u>AND</u></b></p> <ul style="list-style-type: none"> <li>• The AE could possibly be explained by factors or causes other than exposure to the IP</li> </ul> <p style="text-align: center;"><b><u>OR</u></b></p> <ul style="list-style-type: none"> <li>• The administration of IP and the occurrence of the AE are reasonably related in time</li> </ul> <p style="text-align: center;"><b><u>AND</u></b></p> <ul style="list-style-type: none"> <li>• The AE is more likely explained by exposure to the IP than by other factors or causes.</li> </ul> |

Factors suggestive of a causal relationship could include (but are not limited to):

- Plausible temporal relationship
- Absence of alternative explanations
- Rarity of event in a given patient or disease state
- Absence of event prior to study drug exposure
- Consistency with study product pharmacology
- Known relationship to underlying mechanism of study drug action
- Similarity to adverse reactions seen with related drug products
- Abatement of AE with discontinuation of study drug, and/or recurrence of AE with reintroduction of study drug



The Investigator's assessment of causality for individual AE reports is part of the study documentation process. Regardless of the Investigator's assessment of causality for individual AE reports, the Sponsor will promptly evaluate all reported SAEs against cumulative product experience to identify and expeditiously communicate possible new safety findings to Investigators and applicable regulatory authorities.

## **10.4 Procedures for Recording Adverse Events**

### **10.4.1 Recording Adverse Events on a eCRF**

Investigators should use precise medical terminology when recording AEs or SAEs on the AE eCRF. Avoid colloquialisms and abbreviations.

Record only one diagnosis, sign, or symptom per event field on the AE eCRF (eg, nausea and vomiting should not be recorded in the same entry, but as 2 separate entries).

In order to classify AEs and diseases, preferred terms will be assigned by the Sponsor to the original terms entered on the AE eCRF, using MedDRA (Medical Dictionary for Regulatory Activities) terminology.

#### **10.4.1.1 Diagnosis versus Signs and Symptoms**

The Investigator will attempt to establish a diagnosis of the event based on signs, symptoms, and/or other clinical information. Whenever possible, the diagnosis (not the individual signs/symptoms) will be documented as the AE/SAE. Using accepted medical terminology, enter the diagnosis (if known). If not known, enter sign(s) and/or symptom(s). If a diagnosis subsequently becomes available, then this diagnosis should be entered on the AE (or SAE, as appropriate) eCRF, replacing the original entries where appropriate.

#### **10.4.1.2 Adverse Events Occurring Secondary to Other Events**

In general, AEs occurring secondary to other events (eg, cascade events) should be identified by their primary cause. For example, if severe diarrhea is known to have resulted in dehydration, it is sufficient to record only diarrhea as an AE or SAE on the AE eCRF. However, medically important events that may be linked and/or separated in time should be recorded as independent events on the AE eCRF. For example, if severe hemorrhage leads to renal failure, both events should be recorded separately on the AE eCRF.

#### **10.4.1.3 Persistent or Recurrent Adverse Events**

A persistent AE (duration of adverse event > 7 days) is one that extends continuously, without resolution, between subject evaluation time points. Events that change in severity





necessitate the recording of an additional AE. AEs that do not have a change in severity should be recorded only once on the eCRF.

A recurrent AE is one that occurs and resolves between subject evaluation time points, but then subsequently recurs. All recurrences of the AE should be recorded on the AE eCRF. For example, if a subject has an adverse event of ALT increased that subsequently resolves, but the subject's ALT increases again, that should be reported as two adverse events – the initial ALT increase, and the second ALT increase.

#### **10.4.1.4 Abnormal Laboratory Values**

Laboratory test results will be recorded on the laboratory results pages of the eCRF, or appear on electronically produced laboratory reports submitted directly from the central laboratory, if applicable.

Any laboratory result abnormality fulfilling the criteria for a SAE or EOSI should be reported as such, and recorded in the AE eCRF.

Any laboratory result abnormality of CTCAE Grade 4 or 5 should be recorded as an SAE in the AE eCRF.

A clinical laboratory abnormality is considered clinically significant and should be documented as an AE if not refuted by a repeat test to confirm the abnormality and **any** one or more of the following conditions is met:

- Accompanied by clinical symptoms
- Requiring a change in concomitant therapy (eg, addition of, interruption of, discontinuation of, or any other change in a concomitant medication, therapy or treatment).
- The abnormality suggests a disease and/or organ toxicity
- The abnormality is of a degree that requires active management (eg, change of dose, discontinuation of study drug, more frequent follow-up assessments, further diagnostic investigation, etc.)

**This applies to** any protocol and non-protocol specified safety and efficacy laboratory result from tests performed after the first dose of study medication that falls outside the laboratory reference range and meets the clinical significance criteria.

**This does not apply to** any abnormal laboratory result that falls outside the laboratory reference range but that does not meet the clinical significance criteria (these will be analyzed and reported as laboratory abnormalities), those that are considered AEs of the type

explicitly exempted by the protocol, or those which are a result of an AE that has already been reported.

For purposes of this study, laboratory tests showing a decreased level of FVIII activity should not be reported as adverse events unless there is an impact to clinical outcomes (eg, increased rate of bleeding, worsening of joint disease).

#### **10.4.1.5 Pre-existing Conditions**

A pre-existing condition is one that is present prior to administration of BMN 270. Such conditions should be recorded as medical history on the appropriate eCRF.

A pre-existing condition should be recorded as an AE or SAE during the study **only** if the frequency, intensity, or character of the condition worsens during the study period. It is important to convey the concept that a pre-existing condition has changed by including applicable language in the verbatim description of the event (eg, *more frequent* headaches).

#### **10.4.1.6 General Physical Examination Findings**

At screening, any clinically significant abnormality should be recorded as a pre-existing condition (refer to Section 10.4.1.5). During the study, any new clinically significant findings and/or abnormalities discovered on physical examination that meet the definition of an AE (or an SAE) must be recorded and documented as an AE or SAE on the AE eCRF.

#### **10.4.1.7 Hospitalization, Prolonged Hospitalization, or Surgery**

Any AE that results in hospitalization or prolonged hospitalization should be documented and reported as an SAE unless specifically instructed otherwise in this protocol (refer to Section 10.2).

There are some hospitalization scenarios that do not require reporting as an SAE when there is no occurrence of an AE. These scenarios include planned hospitalizations or prolonged hospitalizations to:

- Perform a protocol-mandated efficacy measurement
- Undergo a diagnostic or elective surgical procedure for a pre-existing medical condition that has not worsened
- Insert an in-dwelling IV catheter (such as a Port-a-Cath or other brand, if applicable) for administration of study drug or FVIII replacement therapy
- Receive scheduled therapy (study drug or otherwise) for the study indication



#### **10.4.1.8 Deaths**

All deaths that occur during the AE reporting period (refer to Section 10.3.1), regardless of attribution, will be recorded on the AE eCRF and expeditiously reported to the Sponsor as an SAE.

When recording a death, the event or condition that caused or contributed to the fatal outcome should be recorded as the single medical concept on the eCRF. If the cause of death is unknown and cannot be ascertained at the time of reporting, record “Unexplained Death” or “Death of Unknown Cause” on the AE eCRF.

#### **10.4.1.9 Pregnancy**

Although not an AE per se, pregnancy in the partner of a subject taking trial medication should be reported expeditiously to the Sponsor to facilitate outcome monitoring by the Sponsor. Pregnancy in partner should be reported during the period up to 5 years after viral infusion.

Pregnancy in a partner should be reported within 24 hours of the site becoming aware of the pregnancy by entering the information on the Pregnancy eCRF and submitting to BPV within 24 hours of the site becoming aware of the event. The Investigator must make every effort to follow the subject’s partner (with that partner’s consent) through resolution of the pregnancy (delivery or termination) and to report the resolution on the Pregnancy Follow-up eCRF. In the event of pregnancy in the partner of a study subject, the Investigator should make every reasonable attempt to obtain the woman’s consent for release of protected health information.

Abortion, whether therapeutic or spontaneous, should always be classified as an SAE (as the Sponsor considers these to be medically significant), recorded on the AE eCRF, and expeditiously reported to the Sponsor as an SAE.

### **10.5 Reporting Requirements**

#### **10.5.1 Expedited Reporting Requirements**

All SAEs and EOSI that occur during the course of the AE Reporting Period (refer to Section 10.3.1), whether or not considered related to study drug, must be reported by entering the information in the AE eCRF and submitting to BPV within 24 hours of the site becoming aware of the event. Investigators should not wait to collect information that fully documents the event before notifying BPV of an SAE. BioMarin may be required to report certain SAEs to regulatory authorities within 7 calendar days of being notified about the event; therefore, it is important that Investigators submit any information requested by BioMarin as soon as it becomes available. IND safety reports will be submitted within 7 calendar days for



fatal or life-threatening unexpected suspected adverse reactions (SUSARs) and within 15 calendar days for other non-life-threatening SUSARs

The Sponsor is responsible for identifying, preparing and reporting all SUSARs to the relevant competent authorities, ethics committees and Investigators in accordance with the requirements identified in the Clinical Trials Regulations.

If the EDC is unavailable, all SAEs should be reported to BPV by completing the SAE Report Form and faxing or emailing the completed form to BPV within 24 hours of the site becoming aware of the event. Once the EDC is available, the information should be entered in the AE eCRF.

### **10.5.2 Institutional Review Board or Independent Ethics Committee Reporting Requirements**

Reporting of SAEs to the Independent Ethics Committee (IEC) or Institutional Review Board (IRB) will be done in compliance with the standard operating procedures and policies of the IEC/IRB and with applicable regulatory requirements. Adequate documentation must be obtained by BioMarin showing that the IEC/IRB was properly and promptly notified as required.

### **10.6 Follow-up of Subjects after Adverse Events**

After the initial AE/SAE/EOSI report, the Investigator is required to proactively follow each subject at subsequent visits/contacts. All AEs/SAEs/EOSI will be followed until resolution, stabilization, the event is otherwise explained, or the subject is lost to follow-up. Resolution of AEs/SAEs/EOSI (with dates) should be documented on the AE eCRF and submitted to BioMarin Pharmacovigilance and in the subject's medical record to facilitate source data verification.

For some SAEs and EOSI, the Sponsor may follow up by telephone, fax, electronic mail, and/or a monitoring visit to obtain additional case details (eg, hospital discharge summary, consultant report, or autopsy report) deemed necessary to appropriately evaluate the SAE or EOSI report.

### **10.7 Post-Study Adverse Events**

At the last scheduled visit, the Investigator should instruct each subject to report, to the Investigator and/or to BPV directly, any subsequent SAEs that the subject's personal physician(s) believes might be related to prior study drug.



The Investigator should notify the study Sponsor of any death or SAE occurring at any time after a subject has discontinued or terminated study participation, if the Investigator believes that the death or SAE may have been related to prior study drug. The Sponsor should also be notified if the Investigator should become aware of the development of cancer or of a congenital anomaly in a subsequently conceived offspring of a subject that participated in this study.

### **10.8 Urgent Safety Measures**

The regulations governing clinical trials state that the Sponsor and Investigator are required to take appropriate urgent safety measures to protect subjects against any immediate hazards that may affect the safety of subjects, and that the appropriate regulatory bodies should be notified according to their respective regulations. According to the European Union (EU) Clinical Trial Directive 2001/20/EC, "...in the light of the circumstances, notably the occurrence of any new event relating to the conduct of the trial or the development of the investigational medicinal product where that new event is likely to affect the safety of the patients, the Sponsor and the Investigator shall take appropriate urgent safety measures to protect the patients against any immediate hazard. The Sponsor shall forthwith inform the competent authorities of those new events and the measures taken and shall ensure that the IRB/IEC/REB is notified at the same time."

The reporting period for these events which may require the implementation of urgent safety measures is the period from the time of signing of the ICF through the completion of the last study visit or at the Early Termination Visit (ETV). Investigators are required to report any events which may require the implementation of urgent safety measures to BioMarin within 24 hours.

Examples of situations that may require urgent safety measures include discovery of the following:

- Lack of study scientific value, or detrimental study conduct or management
- Discovery that the quality or safety of the IP does not meet established safety requirements



---

### 10.9 BioMarin Pharmacovigilance Contact Information

Contact information for BioMarin Pharmacovigilance is as follows:

BioMarin Pharmaceutical Inc.

Address 105 Digital Drive  
Novato, CA 94949  
Phone: +1 (415) 506-6179  
Fax: +1 (415) 532-3144  
E-mail: [drugsafety@bmrn.com](mailto:drugsafety@bmrn.com)

The Investigator is encouraged to discuss with the Medical Monitor any AEs for which the issue of seriousness is unclear or questioned. Contact information for the Medical Monitor is as follows:

Name: PI [REDACTED], MD, MPhil  
Address: 105 Digital Drive  
Novato, CA 94949 USA  
Phone: PI [REDACTED]  
E-mail: PI [REDACTED]



## **11 APPROPRIATENESS OF MEASUREMENTS**

The measures of efficacy to be used in this study are standard, ie, widely used and generally recognized as reliable, accurate, and relevant (able to discriminate between effective and ineffective agents). The measures of safety used in this study are routine clinical and laboratory procedures.

The chromogenic FVIII assay and the one-stage clot FVIII assay are both validated and utilize CE marked reagents. The exploratory FVIII activity assay will be used for exploratory purposes only.



---

## 12 STUDY PROCEDURES

### 12.1 Prestudy

An ICF must be signed and dated by the patient, the Investigator or designee and witness (if required) before any study-related procedures are performed.

### 12.2 Screening Visit

Screening assessments should be performed within 28 days of BMN 270 infusion (and must be performed within 42 days prior to BMN 270 infusion), while baseline assessments will take place within 7 days prior to BMN 270 infusion (Day 1). Should the screening visit occur within 30 days of the drug infusion, physical examination, vital signs, blood chemistry, LFTs, hematology, urine tests, and coagulation tests do not need to be repeated at Baseline.

The following procedures will be performed during the Screening Period:

- Demographics (age, sex, race, ethnicity)
- Full medical history, including hemophilia A history, Hepatitis B, Hepatitis C, and HIV.
- Complete Physical Examination
- Height and weight
- Vital Signs (systolic and diastolic blood pressure, heart rate, respiration rate, and temperature)
- Assessment of Adverse Events and Concomitant Medications
- Documentation of bleeding episodes and FVIII usage (by either subject or clinical information) for the previous 12 months
  - Further information on details to be included in documentation of previous bleeding episodes and FVIII usage, refer to the On Site File Binder.
- Distribution of subject diaries and training in diary completion
- Electrocardiogram
- Liver Ultrasound
- Samples for hFVIII Assays
  - Baseline FVIII activity – chromogenic FVIII assay
  - Baseline FVIII activity level – one-stage clot FVIII assay
  - hFVIII coagulation activity exploratory assay (collected but not tested prior to enrollment)



- hFVIII inhibitors (Bethesda assay with Nijmegen modification)
- hFVIII total antibody assay (collected but not tested prior to enrollment)
- hFVIII protein assay (collected but not tested prior to enrollment)
- Blood sample for AAV5 total antibody (TAb) assay
- Screen for Hepatitis B, Hepatitis C, and HIV if required (subjects with documented negative results 30 days prior to informed consent being obtained do not need to be retested)
  - Hepatitis B screening should include HBsAg, HBsAb, and HBcAb.
- Blood chemistry, hematology, and coagulation tests (refer to [Table 9.7.8.2.1](#))
- Urine Tests (refer to [Table 9.7.8.2.1](#))
- Liver Function Tests (refer to [Table 9.7.8.3.1](#))
- Blood samples for Biomarker testing (including HLA genotyping and FVIII genotyping status)

### 12.2.1 “Smart Rescreening” Visit

Subjects who undergo smart rescreening must complete the rescreening assessments and receive the infusion within 90 days of signing the original consent. Subjects who do not complete dosing within 90 days will be required to re-consent and undergo all screening procedures. Subjects may not undergo smart rescreening more than once.

If a patient has to be screened again because the original assessments have fallen out of the 28 + 14 day period allowed for Screening (refer to Section [12.2](#)), then only the following assessments need to be performed (rather than the full list indicated in Section [12.2](#)) for the patient to be successfully re-screened for the study:

- Vital signs
- Assessment of Adverse Events and Concomitant Medications
- Documentation of bleeding episodes and FVIII usage (by either subject or clinical information)
- hFVIII Assays (only the hFVIII inhibitor level (Bethesda assay with Nijmegen modification))
- AAV5 Total Antibody assay
- Blood chemistry, hematology, and coagulation tests (refer to [Table 9.7.8.2.1](#))
- Urine Tests (refer to [Table 9.7.8.2.1](#))
- Liver Function Tests (refer to [Table 9.7.8.3.1](#))

### 12.3 Baseline Visit

Baseline values will be recorded from 1 to 7 days prior to the treatment visit. The following procedures will be performed during the Baseline Period:

- Brief physical examination
- Vital signs
- Assessment of Adverse Events and Concomitant Medications
- Documentation of bleeding episodes and FVIII usage (by either subject or clinical information)
- Blood sample for AAV5 TI assay
- Blood sample for AAV5 TAb assay
- Blood chemistry, hematology, and coagulation tests (refer to [Table 9.7.8.2.1](#))
- Urine Tests (refer to [Table 9.7.8.2.1](#))
- Liver Function Tests (refer to [Table 9.7.8.3.1](#))
- Samples for hFVIII Assays
  - Baseline FVIII activity – chromogenic FVIII assay
  - Baseline FVIII activity level – one-stage clot FVIII assay
  - hFVIII coagulation activity exploratory assay
  - hFVIII inhibitors (Bethesda assay with Nijmegen modification)
  - hFVIII total antibody assay
  - hFVIII protein assay
- PBMC collection for CTL baseline
- Von Willebrand Factor Antigen (VWF:Ag)
- Direct Thrombin test
- TGA Assay
- PCR of vector DNA in blood, saliva, urine, semen, and stools
- Exploratory biomarker assessments
- Haemo-QoL-A assessment
- EQ-5D-5L
- Hemophilia Activities List (HAL)



- Work Productivity and Activity Impairment plus Classroom Impairment Questions: Hemophilia Specific (WPAI+CIQ:HS) questionnaire
- Patient Reported Outcomes, Burdens, and Experiences (PROBE) questionnaire

#### **12.4 Treatment Visit/BMN 270 Infusion Visit (Day 1)**

There will be one treatment visit for each subject. Subjects will remain in the clinic for at least 8 hours for the BMN 270 Infusion Visit. The following procedures will be performed during the BMN 270 Infusion Visit:

- Brief physical examination
- Assessment of Adverse Events and Concomitant Medications
- AAV5 TAb Assay (sample collected pre-infusion for analysis)
- Fasting lipid panel (blood triglycerides, total cholesterol, HDL cholesterol, and LDL cholesterol) (sample collected pre-infusion)
  - Subjects will fast for at least 8 hours prior to pre-infusion laboratory sampling on the day of the infusion visit.
- BMN 270 Infusion
- Vital Signs
  - Vital signs will be recorded prior to BMN 270 infusion and then every 15 minutes ( $\pm$  5 minutes) during BMN 270 infusion. Following infusion, vital signs will be monitored every 1 hour ( $\pm$  5 minutes) for at least 8 hours during the subject's stay in the clinic.
- PCR of vector DNA in blood, saliva, urine, semen, and stools
  - Collection of samples for PCR testing should occur between 2 and 24 hours after the BMN 270 infusion has been completed

In case of hypersensitivity or adverse drug reaction, safety assessment, including physical examination and vital signs, will be done and additional blood samples will be collected within 1 hour of the hypersensitivity reaction (eg, tryptase, C3, C3a, C4, C5, and C5a, as well as possible additional exploratory testing) and one sample for IgE (and possible additional exploratory testing) between 8-24 hours after the reaction, if possible. In-patient observation can be extended and additional blood samples can be collected if deemed necessary at the discretion of the Investigator and Medical Monitor.

#### **12.5 BMN 270 Infusion Follow-Up Visits – Weeks 1-26**

After BMN 270 has been infused, subjects will return to the study site every week ( $\pm$  48 hours) during Weeks 1-26, when the following procedures will be completed:



### 12.5.1 Once per week (Weeks 1 through 26)

The following procedures will be performed at one visit per week from Weeks 1 through 20:

- Brief physical examination (complete physical examination at Week 26)
- Assessment of Adverse Events and Concomitant Medications (including review of subject diary for bleeding and FVIII use)
- Vital Signs
- Liver Function Tests (refer to [Table 9.7.8.3.1](#))
  - LFTs may be monitored more or less frequently (and in particular when ALT values are  $>1.5x$  ULN) based on discussion between the Medical Monitor and the Investigator and review of subject data, but LFTs will be monitored at least twice weekly during periods when a subject's ALT is  $\geq 3x$  ULN.
- Samples for FVIII Assays
  - FVIII activity level (chromogenic FVIII assay)
  - FVIII activity level (one-stage clot FVIII assay)
  - FVIII coagulation activity exploratory assay
  - Bethesda assay (with Nijmegen modification) for hFVIII inhibitor level
  - FVIII protein assay

### 12.5.2 Week 1 – Day 4

On Day 4 of Week 1, the following procedures will be performed:

- PCR of vector DNA in blood, saliva, urine, semen, and stools
- Liver Function Tests (refer to [Table 9.7.8.3.1](#))

### 12.5.3 Week 1 – Day 8

On Day 8, the following procedures will be performed, in addition to the weekly assessments required in Section [12.5.1](#):

- PCR of vector DNA in blood, saliva, urine, semen, and stools

### 12.5.4 Every 2 Weeks (Week 2, 4, 6, 8, 10, 12, 14, 16, 18, 20, 22, 24, and 26)

At Weeks 2, 4, 6, 8, 10, 12, 14, 16, 18, 20, 22, 24, and 26 the following procedure will be performed:

- PBMC collection

**12.5.5 Weeks 2, 4, 10, 16, 22, and 26**

At Weeks 2, 4, 10, 16, 22, and 26 the following procedure will be performed:

- Blood chemistry, hematology, and coagulation tests (refer to [Table 9.7.8.2.1](#))

**12.5.6 Weeks 2, 3, 4, 6, 8, 12, 16, 20, 24, and 26**

At Weeks 2, 3, 4, 6, 8, 12, 16, 20, 24, and 26, the following procedure will be performed:

- PCR of vector DNA in blood, saliva, urine, semen, and stools
  - Collection to occur until at least 3 consecutive negative results are obtained. Semen samples should continue to be collected and tested through Week 12, even if 3 consecutive negative results in that compartment have been recorded prior to that time point.

**12.5.7 Weeks 4, 12, and 26**

At Weeks 4, 12, and 26, the following procedure will be performed:

- Haemo-QoL-A assessment
- EQ-5D-5L
- HAL
- WPAI+CIQ:HS
- PROBE

**12.5.8 Every 4 Weeks (Weeks 4, 8, 12, 16, 20, and 24) Plus Week 26**

At Weeks 4, 8, 12, 16, 20, 24, and 26, the following procedures will be performed:

- Weight (not performed at Week 26)
- FVIII antibody titer

**12.5.9 Every 8 Weeks (Weeks 8, 16, and 24)**

At Weeks 8, 16, and 24, the following procedures will be performed:

- AAV5 TAb assay
- AAV5 TI assay

**12.5.10 Weeks 6, 13, 16, 20, 24, and 26**

At Weeks 6, 13, 16, 20, 24, and 26, the following procedures will be performed:

- Exploratory biomarker assessments



### **12.5.11 Weeks 12 and 26**

At Weeks 12 and 26, the following procedure will be performed:

- Urine Tests (refer to [Table 9.7.8.2.1](#))

### **12.5.12 Week 13 and 26**

At Weeks 13 and 26, the following procedures will be performed:

- Direct Thrombin test
- VWF:Ag

### **12.5.13 Week 16**

At Week 16, the following procedure will be performed:

- Test for Hepatitis B and Hepatitis C reactivation (only in subjects with evidence of prior exposure to hepatitis B and/or hepatitis C)
  - Subjects who receive therapeutic oral corticosteroids prior to Week 16 do not need to complete the Week 16 reactivation assessment; instead, they will be tested for hepatitis B and hepatitis C reactivation at the time points listed in [Table 9.1.5](#).

### **12.5.14 Week 20, 24, and 26**

At Week 20, 24, and 26, the following procedure will be performed:

- TGA Assay

## **12.6 Post-Infusion Follow-Up – Weeks 27-52**

During Weeks 27-36, subjects will return to the study site weekly ( $\pm$  48 hours). During Weeks 37-52, subjects will return to the study site every 2 weeks (Week 38, 40, 42, 44, 46, 48, 50, and 52) ( $\pm$  1 week). At these visits, the following procedures will be completed:

### **12.6.1 Every Visit**

At every visit (Weeks 27-36, 38, 40, 42, 44, 46, 48, 50, and 52), the following procedures will be performed:

- Physical examination
  - Brief physical examination should be performed at all weeks except Week 26, when a complete physical examination should be performed
- Assessment of Adverse Events and Concomitant Medications (including review of subject diary for bleeding and FVIII use)
- Vital Signs

- Liver Function Tests (refer to [Table 9.7.8.3.1](#))
  - LFTs may be monitored more or less frequently (and in particular when ALT values are  $>1.5x$  ULN) based on discussion between the Medical Monitor and the Investigator and review of subject data, but LFTs will be monitored at least twice weekly during periods when a subject's ALT is  $\geq 3x$  ULN.
- FVIII Assays
  - FVIII activity level (chromogenic FVIII assay)
  - FVIII activity level (one-stage clot FVIII assay)
    - FVIII coagulation activity exploratory assay
    - Bethesda assay (with Nijmegen modification) for FVIII inhibitor level
    - FVIII protein assay

#### **12.6.2 Weeks 28, 30, 32, 34, 36, 44, and 52**

At Weeks 28, 30, 32, 34, 36, 44, and 52, the following procedure will be performed:

- PBMC collection

#### **12.6.3 Every 4 Weeks (Weeks 28, 32, 36, 40, 44, 48, 52)**

At Weeks 28, 32, 36, 40, 44, 48, and 52, the following procedure will be performed:

- Weight

#### **12.6.4 Weeks 32, 36, 44, and 52**

At Weeks 32, 36, 44, and 52, the following procedures will be performed:

- Blood chemistry, hematology, and coagulation tests (refer to [Table 9.7.8.2.1](#))
- FVIII antibody titer

#### **12.6.5 Weeks 32, 36, 40, 44, 48, and 52**

At Weeks 32, 36, 40, 44, 48, and 52, the following procedures will be performed:

- Exploratory biomarker assessments
- TGA Assay
- PCR of vector DNA in blood, saliva, urine, semen, and stools
  - Sample testing to occur until at least 3 consecutive negative sample results have been obtained. Subjects who have not had 3 consecutive negative semen samples by Week 52 should continue to have PCR testing of semen every 4 weeks until 3 consecutive negative samples are documented (or upon consultation between the Investigator and Medical Monitor).

**12.6.6 Week 32, 36, and 52**

At Week 32, 36, and 52, the following procedure will be performed:

- AAV5 TAb Assay
- AAV5 TI Assay

**12.6.7 Week 38 and 52**

At Weeks 38 and 52, the following procedures will be performed:

- Urine Tests (refer to [Table 9.7.8.2.1](#))
- Direct Thrombin test
- VWF:Ag

**12.6.8 Week 52**

At Week 52, the following procedures will be performed:

- Haemo-QoL-A assessment
- EQ-5D-5L
- HAL
- WPAI+CIQ:HS
- PROBE

**12.7 Post-Infusion Follow-Up – Years 2-5**

During Years 2-5, at applicable sites, certain study assessments may be performed by a mobile nursing (MN) professional at the patient's home or another suitable location, such as their school or office, to improve access and convenience for patients participating in the study. The Sponsor may select a healthcare company that will be responsible for providing MN services for participating sites (the MN vendor). The MN vendor is responsible for ensuring that all MN professionals are licensed, qualified, and in good standing, as per applicable regulations, and that appropriate background checks have been performed. If the investigator at a participating site determines that MN services are appropriate for a patient and the patient gives written informed consent to participate in MN visits, the MN network will communicate with the patient and the patient's site. MN visits will be allowed for the Q4W (during Year 2) and Q6W (during Years 3-5) visits; the Q3M visits during Years 2-5 will not be performed by an MN professional but will be done at the study site.

During Years 2-5 of Post-Infusion Follow-up, the following procedures will be completed:





### 12.7.1 Year 2 – Every 4 Weeks

During Year 2, every 4 weeks (+ 2 weeks, or as scheduled to align with visits for performing assessments to be done every 3 months [Section 12.7.3]), the following procedures will be performed:

- Assessment of Adverse Events and Concomitant Medications (including review of subject diary for bleeding and FVIII use)
- Liver Function Tests (refer to [Table 9.7.8.3.1](#))
  - LFTs may be monitored more or less frequently (and in particular when ALT values are >1.5x ULN) based on discussion between the Medical Monitor and the Investigator and review of subject data, but LFTs will be monitored at least twice weekly during periods when a subject's ALT is  $\geq$  3x ULN.
- FVIII Assays
  - FVIII activity level (chromogenic FVIII assay)
  - FVIII activity level (one-stage clot FVIII assay)
  - FVIII coagulation activity exploratory assay
  - Bethesda assay (with Nijmegen modification) for FVIII inhibitor level
  - FVIII protein assay
- PCR of vector DNA in blood, saliva, urine, semen, and stools (if required)
  - Sample testing during Year 2 is not required if at least 3 consecutive samples are negative during the Post-Infusion Follow-Up period in Weeks 1-52. Subjects who have not had 3 consecutive negative semen samples by Week 52 should continue to have PCR testing of semen every 4 weeks during Years 2 until 3 consecutive negative samples are documented (or upon consultation between the Investigator and Medical Monitor).

### 12.7.2 Years 3-5 – Every 6 Weeks

During Years 3-5, every 6 weeks ( $\pm$  2 weeks), the following procedures will be performed:

- Assessment of Adverse Events and Concomitant Medications (including review of subject diary for bleeding and FVIII use)
- Liver Function Tests (refer to [Table 9.7.8.3.1](#))
  - LFTs may be monitored more or less frequently (and in particular when ALT values are >1.5x ULN) based on discussion between the Medical Monitor and the Investigator and review of subject data, but LFTs will be monitored at least twice weekly during periods when a subject's ALT is  $\geq$  3x ULN.

- FVIII Assays
  - FVIII activity level (chromogenic FVIII assay)
  - FVIII activity level (one-stage clot FVIII assay)
  - FVIII coagulation activity exploratory assay
  - Bethesda assay (with Nijmegen modification) for FVIII inhibitor level
    - If a subject tests positive in the Bethesda assay (with Nijmegen modification) during Years 3-5, a fresh sample should be collected within 4 weeks of the initial visit that had a positive result.
  - FVIII protein assay
- PCR of vector DNA in blood, saliva, urine, semen, and stools (if required)
  - Sample testing during Years 3-5 is not required if at least 3 consecutive samples are clear by the end of Year 2. Subjects who have not had 3 consecutive negative semen samples by the end of Year 2 should continue to have PCR testing of semen every 6 weeks during Years 3-5 until 3 consecutive negative samples are documented (or upon consultation between the Investigator and Medical Monitor).

### 12.7.3 Years 2-5 – Every 3 Months

Every 3 months ( $\pm$  2 weeks), the following procedures will be performed:

- Physical examination
  - Complete physical examination will be performed every 52 weeks; brief physical examination may be performed at other visits.
- Assessment of Adverse Events and Concomitant Medications (including review of subject diary for bleeding and FVIII use)
- Liver Function Tests (refer to [Table 9.7.8.3.1](#))
  - LFTs may be monitored more or less frequently (and in particular when ALT values are  $>1.5x$  ULN) based on discussion between the Medical Monitor and the Investigator and review of subject data, but LFTs will be monitored at least twice weekly during periods when a subject's ALT is  $\geq 3x$  ULN.
- FVIII Assays
  - FVIII activity level (chromogenic FVIII assay)
  - FVIII activity level (one-stage clot FVIII assay)
  - FVIII coagulation activity exploratory assay
  - Bethesda assay (with Nijmegen modification) for FVIII inhibitor level

- If a subject tests positive in the Bethesda assay (with Nijmegen modification) during Years 3-5, a fresh sample should be collected within 4 weeks of the initial visit that had a positive result.
  - FVIII protein assay
- Vital Signs
- AAV5 TAb Assay
- AAV5 TI Assay
- FVIII antibody titer
- Exploratory biomarker assessments
- PBMC collection
- VWF:Ag
- Direct Thrombin test
- TGA Assay
- PCR of vector DNA in blood, saliva, urine, semen, and stools (if required)
  - Sample testing during Years 2-5 is not required if at least 3 consecutive samples are negative during the Post-Infusion Follow-Up period in Weeks 1-52. Subjects who have not had 3 consecutive negative semen samples by Week 52 should continue to have PCR testing of semen every 4 weeks (during Year 2) or every 6 weeks (during Years 3-5) until 3 consecutive negative samples are documented (or upon consultation between the Investigator and Medical Monitor).

#### 12.7.4 Years 2-5 – Every 6 Months

Every six months starting at the Week 78 visit (ie, 26 weeks after the Week 52 visit at the end of Year 1 of the Long-Term Follow-up period), the following procedures will be performed:

- Weight
- Blood chemistry, hematology, and coagulation tests (refer to [Table 9.7.8.2.1](#))
- Urine Tests (refer to [Table 9.7.8.2.1](#))
- Haemo-QoL-A assessment
- EQ-5D-5L
- HAL

- WPAI+CIQ:HS
- PROBE

## **12.8 Early Termination Visit**

The Early Termination visit will occur on the date the subject withdraws from the study, even if the date does not correspond to a protocol-specific visit.

If a subject leaves the study prior to the Week 260 visit, the subject will be asked to return to the study site and complete an Early Termination visit. At the Early Termination visit, as many of the following assessments as possible should be done:

- Physical examination
- Weight
- Assessment of Adverse Events and Concomitant Medications (including review of subject diary for bleeding and FVIII use)
- Vital Signs
- Blood chemistry, hematology, and coagulation tests (refer to [Table 9.7.8.2.1](#))
- Urine Tests (refer to [Table 9.7.8.2.1](#))
- Liver Function Tests (refer to [Table 9.7.8.3.1](#))
- FVIII Assays
  - FVIII activity level (chromogenic FVIII assay)
  - FVIII activity level (one-stage clot FVIII assay)
  - FVIII coagulation activity exploratory assay
  - Bethesda assay (with Nijmegen modification) for FVIII inhibitor level
  - FVIII protein assay
- AAV5 TAb Assay
- AAV5 TI Assay
- FVIII antibody titer
- Exploratory biomarker assessments
- PBMC collection
- VWF:Ag
- Direct Thrombin test
- TGA Assay



- 
- PCR of vector DNA in blood, saliva, urine, semen, and stools
    - Sample testing at the ETV is not required if at least 3 consecutive samples were clear during the Post-Infusion Follow-Up period.
  - Haemo-QoL-A assessment
  - EQ-5D-5L
  - HAL
  - WPAI+CIQ:HS
  - PROBE

### **12.9 End of Study**

The study will end after the last subject yet to complete the last Long-Term Follow-Up visit (Week 260) does so, has transferred to another BMN 270 study, is withdrawn from the study, or discontinues from the study. BioMarin reserves the right to discontinue the study any time for clinical or administrative reasons and to discontinue participation of an individual Investigator or site for clinical or administrative reasons, including, but not limited to, poor enrollment or noncompliance with procedures of the protocol or GCP. In addition, the study may be terminated if, in the opinion of BioMarin, the safety of the study subjects may be compromised.



### **13 DATA QUALITY ASSURANCE**

BioMarin personnel or designees will visit the study site prior to initiation of the study to review with the site personnel information about the IP, protocol and other regulatory document requirements, source document requirements, eCRFs, monitoring requirements, and procedures for reporting AEs, including SAEs.

At visits during and after the study, a CRA will monitor the site for compliance with regulatory documentation, with a focus on accurate and complete recording of data on eCRFs from source documents, adherence to protocol, randomization (if applicable), SAE reporting and drug accountability records.

Data quality control and analysis will be performed by BioMarin or a designee, based on a predefined analysis plan.



---

## 14 STATISTICAL METHODS AND DETERMINATION OF SAMPLE SIZE

### 14.1 Statistical and Analytical Plans

The statistical analysis plan (SAP) will provide additional details on the planned statistical analysis. Unless otherwise stated, all analyses will be performed using SAS.

#### 14.1.1 Interim Analyses

An interim analysis is planned after 20 treated subjects have completed the Week 26 visit (or have discontinued study participation prior to Week 26).

The primary efficacy endpoint for the interim analysis is change in the hFVIII activity, as measured by one-stage clotting assay, during Weeks 23-26 post-BMN 270 infusion from baseline. Each subject's hFVIII activity during Weeks 23-26 is defined as the median of the values obtained during this 4-week window. Values for hFVIII activity will be excluded if obtained within 72 hours since the last infusion of exogenous FVIII protein concentrates. A 2-sided one-sample t-test will be used to test the null hypothesis that the change is 0. In addition, subjects' hFVIII activity post-Week 23, defined as the median of the values obtained from Week 23 to the time of last follow-up, will be analyzed similarly as an important sensitivity analysis, utilizing additional data beyond Week 26. Descriptive summaries of the proportions of subjects whose FVIII activity during Weeks 23-26 and from Week 23 to the time of last follow-up is greater than or equal to select thresholds, such as 15, 25 and 30 IU/dL, and the confidence intervals of the proportions will be provided, respectively. The FVIII activity as measured by chromogenic assay will be analyzed similarly, as a supportive analysis.

The fallback procedure ([Wiens, 2005](#)) will be used to adjust for multiplicity of the interim analysis at Week 26 and the final analysis at Week 52 of the primary efficacy endpoint. (Regardless of the interim analysis results, the study is planned to continue upon the DMC's recommendation, and the final analysis will be performed at Week 52.) At the final analysis at Week 52, the secondary efficacy endpoints will be tested hierarchically; the level of significance will be determined by the fallback procedure.

The secondary and tertiary endpoints will be summarized descriptively at the interim (Week 26) analysis.

The details of the interim analysis, including the control of Type I error rate, will be specified in an interim analysis plan.



### **14.1.2 Procedures for Accounting for Missing, Unused and Spurious Data**

Because the completeness of the data affects the integrity and accuracy of the final study analysis, every effort should be made to ensure complete, accurate, and timely data collection and, therefore, avoid missing data.

Missing data imputation and sensitivity analyses to assess the impact of missing data on the primary and secondary efficacy endpoints analyses are described in the following sections. Additional details regarding the handling of missing data will be provided in the SAP.

### **14.2 Primary Efficacy Endpoint**

For the primary efficacy endpoint at Week 52 (ie, the change in the hFVIII activity during Weeks 49-52 post-BMN 270 infusion from baseline, as measured by one-stage clotting assay), a one-sample t-test will be used to test the null hypothesis that the change is 0 or less against the alternative hypothesis that the change is greater than 0. Descriptive summaries of the proportions of subjects whose FVIII activity during Weeks 49-52 is greater than or equal to select thresholds, such as 15, 25 and 30 IU/dL, and the confidence intervals of the proportions will also be provided. The FVIII activity as measured by chromogenic assay will be analyzed similarly, as a supportive analysis.

For a subject with a missing value of the primary endpoint, the median value in the subject's last 4-week window containing a valid observation will be used. Additional analyses will be conducted to examine the sensitivity of the results to the handling of missing data, including analysis using observed cases, and a mixed model for repeated measures (MMRM) approach. Further detail will be provided in the SAP.

The analyses for the primary endpoint will be performed using the efficacy analysis set as defined in Section 14.8.

### **14.3 Secondary Efficacy Endpoints**

The primary analyses for the secondary endpoints will be performed on the 110 subjects in the efficacy analysis set who will be followed up for approximately 6 months in the non-interventional study 270-902 prior to their enrollment in 270-301. The baseline values will be derived from the prospectively collected data in 270-902.

For the first secondary efficacy endpoint at Week 52 (ie, the change in the annualized utilization (IU/kg) of exogenous FVIII replacement therapy during Weeks 5-52 post-BMN 270 infusion from baseline), a one-sample t-test will be performed to test the null hypothesis that the change is 0 or greater against the alternative hypothesis that the change is less than 0. The missing value of the change will be imputed as 0.





For the second secondary efficacy endpoint at Week 52 (ie, the change in ABR, annualized bleeding rate, during Weeks 5-52 post-BMN 270 infusion from baseline), a one-sample t-test will be performed to test for non-inferiority of BMN 270 against FVIII prophylaxis (ie, the baseline ABR calculated using subjects' data collected as part of 270-902) using a non-inferiority margin of 3.5, ie, to test the null hypothesis that the change is 3.5 or greater against the alternative hypothesis that the change is less than 3.5. If non-inferiority is demonstrated, the test for superiority of BMN 270 against FVIII prophylaxis will be performed. The missing value of the change will be imputed using the median value of the changes of all observed cases.

A sensitivity analysis is planned to analyze ABR using a generalized linear mixed model assuming negative binomial as the underlying distribution. The model will include period (pre- to post-BMN 270 infusion) as the only factor. The actual number of bleeding episodes will be used as the independent variable with the time period adjustment (animalization) being implemented as the offset.

To assess the impact of missing data, analyses using observed case are planned as sensitivity analyses for the secondary endpoints. Multiple imputation methods may also be performed.

The primary and secondary efficacy hypotheses will be tested hierarchically according to the order described above. Multiple comparison procedures will be described in greater detail in the SAP.

#### **14.4 Immunogenicity**

Analysis of total and neutralizing antibody response and other immunological parameters will be primarily descriptive and involve both inter-subject and intra-subject comparisons.

#### **14.5 Pharmacodynamic Analyses**

Plasma FVIII protein concentrations and FVIII activities determined over the course of the study will primarily be evaluated and summarized with descriptive statistical measures (eg, mean, standard deviation, CV%, min, median, max).

#### **14.6 Safety Analysis**

The Medical Dictionary for Regulatory Activities terminology (MedDRA) will be used by the Sponsor to assign system organ class and preferred term classification to events and diseases, based on the original terms entered on the eCRF.

All AEs will be coded using the current version of MedDRA. The incidence of AEs will be summarized by system organ class, preferred term, relationship to study drug, and severity. A



by-subject listing will be provided for those subjects who experience a serious AE (SAE), including death, or experience an AE associated with early withdrawal from the study or study drug.

Clinical laboratory data will be summarized by the type of laboratory test. For each clinical laboratory test, descriptive statistics will be provided on Baseline as well as all subsequent visits. Descriptive statistics for physical examination results and vital signs will also be provided.

Detailed statistical methods will be provided in the SAP.

#### **14.7 Determination of Sample Size**

One hundred and thirty (130) subjects may be dosed in the study. The sample size for this study is based on clinical and statistical considerations in order to provide sufficient data to assess both safety and efficacy of BMN 270.

For the primary endpoint, a sample size of 130 will provide at least 95% power to demonstrate that the change in hFVIII activity during Weeks 49-52 from baseline is greater than 0, assuming an effect size of 0.6, using a one-sample t-test with a 2-sided significance level of 0.05. The effect size of 0.6 is assumed based on Study 270-201 data. In Study 270-201 cohort 6E13, the mean (SD) of FVIII activity (IU/dL) at Week 52 (based on median values in a 4-week window around Week 52) were estimated as 103.8 (62.4), with a 95% confidence interval for the mean of (46.1 , 161.5). Using the lower limit of the confidence interval and assuming a baseline value of 1 (the largest value allowed per the study's inclusion/exclusion criteria), the effect size of change from baseline is approximately 0.7. For the sample size calculation, an effect size of 0.6 is assumed.

For the secondary endpoints, the analysis will be performed utilizing exogenous FVIII use and bleeding episode data from the 110 subjects whose baseline data will be prospectively collected for approximately 6 months in the non-interventional study 270-902, prior to their enrollment in Study 270-301. An analytic sample size of 110 will provide at least 95% power to demonstrate that the change in the annualized utilization (IU/kg) of exogenous FVIII replacement therapy during Week 5 to Week 52 post-BMN 270 infusion from the baseline is less than 0, assuming an effect size of 0.6 conservatively, using one-sample t-test with a 2-sided significance level of 0.05.

For the analytic sample size calculation of the second secondary endpoint, ABR, it is assumed that the pre- and post-BMN 270 infusion population mean ABRs are 3.5 and 1 respectively, and the distribution of ABRs is negative binomial distribution with a dispersion parameter of 2.2. Given the underlying negative binomial distributions, the



standard deviations of the pre- and post-BMN 270 infusion ABRs are calculated as 7.8 and 1.8 respectively. The mean (SD) of the change from the pre- to post-BMN 270 infusion ABRs are calculated as -2.5 (8) assuming the correlation between pre- and post-BMN 270 infusion ABRs is zero. Under this assumption, an analytic sample size of 110 will also have at least 95% power to demonstrate that the change in the annualized number of bleeding episodes requiring exogenous FVIII replacement treatment (ABR) during Week 5 to Week 52 of the study post-BMN 270 infusion from the baseline ABR is less than 3.5 (non-inferiority margin), using a one-sample t-test with a 2-sided significance level of 0.05. Under the same assumptions, a sample size of 110 will have approximately 90% power to demonstrate that the change is less than 0, ie, superiority of BMN 270 against FVIII prophylaxis.

Overall, the planned sample size will have greater than 80% power for testing the primary and secondary efficacy endpoints hierarchically at the final analysis with a 2-sided significance level of 0.05.

#### **14.8 Analysis Populations**

The efficacy analysis set will consist of all subjects who receive the BMN 270 infusion.

The safety population is the same as the efficacy analysis set.

#### **14.9 Changes in the Conduct of the Study or Planned Analyses**

Only BioMarin may modify the protocol. Any change in study conduct considered necessary by the Investigator will be made only after consultation with BioMarin, who will then issue a formal protocol amendment to implement the change. The only exception is when an Investigator considers that a subject's safety is compromised without immediate action. In these circumstances, immediate approval of the chairman of the IRB/IEC/REB must be sought, and the Investigator should inform BioMarin and the full IRB/IEC/REB within 2 working days after the emergency occurs.

With the exception of minor administrative or typographical changes, the IRB/IEC/REB must review and approve all protocol amendments. Protocol amendments that have an impact on subject risk or the study objectives, or require revision of the ICF, must receive approval from the IRB/IEC/REB prior to their implementation.

When a protocol amendment substantially alters the study design or the potential risks or burden to subjects, the ICF will be amended and approved by BioMarin and the IRB/IEC/REB, and all active subjects must again provide informed consent.



## 15 DATA MONITORING COMMITTEE

An independent DMC will be convened for this study. The duties of the DMC will include:

- Conducting an ongoing review of individual subject safety and efficacy data during the study.
- Recommending whether to enroll subjects at a different dose level (not to exceed 6E13 vg/kg) based on emerging data from 270-301 and the overall risk/benefit analysis of BMN 270.
- Reviewing ongoing safety and efficacy data for comparability of drug manufacturing lots within 270-301 and between 270-201 and 270-301.
- Making other recommendations on the conduct and reporting of the trial based on their evaluation of clinical data.

Details on the composition of the committee, frequency of meetings, and other committee functions and parameters are included in the DMC Charter and in the Statistical Analysis Plan (SAP).



---

## 16 COSTS, COMPENSATION, AND SUBJECT INJURY

There will be no charge to study subjects to be in this study. BioMarin will pay all costs of tests, procedures, and treatments that are part of this study. In addition, after IRB/IEC/REB approval, BioMarin may reimburse the reasonable cost of travel for study-related visits in accordance with BioMarin's travel and reimbursement policy. BioMarin will not pay for any hospitalizations, tests, or treatments for medical problems of any sort related solely to the study subject's disease. Costs associated with such hospitalizations, tests, and treatments should be billed and collected in the way that such costs are usually billed and collected outside the study.

The Investigator should contact BioMarin immediately upon notification that a study subject has been injured by the study drug or by procedures performed as part of the study. Any subject who experiences a study-related injury should be instructed by the Investigator to seek immediate medical treatment at a pre-specified medical institution if possible, or at the closest medical treatment facility if necessary. The subject should be given the name of a person to contact to seek further information about, and assistance with, treatment for study-related injuries. The treating physician should bill the subject's health insurance company or other third party payer for the cost of this medical treatment. If the cost of the medical treatment is not covered by health insurance or another third party that usually pays these costs, then either BioMarin or the institution may pay for reasonable and necessary medical services to treat the injuries caused by the study drug or study procedures. In some jurisdictions, BioMarin is obligated by law to pay for study-related injuries without prior recourse to third party payer billing and/or regardless of fault. If this is the case, BioMarin will comply with the law.



---

## 17 CASE REPORT FORMS AND SOURCE DOCUMENTS

Electronic case report forms will be provided for each subject. The Investigator must review and electronically sign the completed eCRF casebook to verify its accuracy.

eCRFs must be completed using a web-based application developed and validated. Study site personnel will be trained on the application and will enter the clinical data from source documentation. Unless explicitly allowed in the eCRF instructions, blank data fields are not acceptable.

In the event of an entry error, or if new information becomes available, the value will be corrected by deselecting the erroneous response and then selecting or entering the factual response. In compliance with ICH GCP Guidelines and 21 CFR Part 11, the system will require the personnel making the correction to enter a reason for changing the value. The documented audit trail will include the reason for the change, the original value, the new value, the time of the correction and the identity of the operator.

BioMarin's policy is that study data on the eCRFs must be verifiable to the source data, which necessitates access to all original recordings, laboratory reports, and subject records. In addition, all source data should be attributable (signed and dated). The Investigator must therefore agree to allow direct access to all source data. Subjects must also allow access to their medical records, and subjects will be informed of this and will confirm their agreement when giving informed consent. If direct source document verification of study data by the site monitor is prohibited by institutional policy or local law, then the Investigator must make available facilities and/or personnel to allow GCP-compliant source verification to occur. Examples of such methods include certified copies of records which have study data visible but sensitive information redacted, or other GCP-compliant means agreed between the Investigator and the Sponsor.

A site monitor designated by BioMarin will compare the eCRFs with the original source documents at the study site and evaluate them for completeness and accuracy before designating them as "Source Data Verified" (SDV). If an error is discovered at any time or a clarification is needed, the site monitor, or designee, will create an electronic query on the associated field. Site personnel will then answer the query by either correcting the data or responding to the query. The site monitor will then review the response and determine either to close the query or re-query the site if the response does not fully address the question. This process is repeated until all open queries have been answered and closed.

Before a subject's eCRF casebook can be locked, data fields must be source data verified and all queries closed. Refer to the Study Monitoring Plan for details on which fields must be



source data verified. The Investigator will then electronically sign the casebook, specifying that the information on the eCRFs is accurate and complete. The Data Manager, or designee, will then set the status of the forms, visits, and the entire casebook to Locked. Upon completion of the CSR, an electronic copy of each site's casebooks will be copied to a compact disk (CD) and sent to each site for retention with other study documents.



## **18 STUDY MONITORING AND AUDITING**

Qualified individuals designated by BioMarin will monitor all aspects of the study according to GCP and standard operating procedures for compliance with applicable government regulations. The Investigator agrees to allow these monitors direct access to the clinical supplies, dispensing, and storage areas and to the clinical files, including original medical records, of the study subjects, and, if requested, agrees to assist the monitors. The Investigator and staff are responsible for being present or available for consultation during routinely scheduled site visits conducted by BioMarin or its designees.

Members of BioMarin's GCP Compliance Department or designees may conduct an audit of a clinical site at any time before, during, or after completion of the study. The Investigator will be informed if an audit is to take place and advised as to the scope of the audit. Representatives of the FDA or other Regulatory Agencies may also conduct an audit of the study. If informed of such an inspection, the Investigator should notify BioMarin immediately. The Investigator will ensure that the auditors have access to the clinical supplies, study site facilities, original source documentation, and all study files.





## 19 RETENTION OF RECORDS

The Investigator must retain all study records required by BioMarin and by the applicable regulations in a secure and safe facility. The Investigator must consult a BioMarin representative before disposal of any study records, and must notify BioMarin of any change in the location, disposition or custody of the study files. The Investigator /institution must take measures to prevent accidental or premature destruction of essential documents, that is, documents that individually and collectively permit evaluation of the conduct of a study and the quality of the data produced, including paper copies of study records (eg, subject charts) as well as any original source documents that are electronic as required by applicable regulatory requirements.

All study records must be retained for at least 2 years after the last approval of a marketing application in the US or an ICH region and until (1) there are no pending or contemplated marketing applications in the U.S. or an ICH region or (2) at least 2 years have elapsed since the formal discontinuation of clinical development of the IP. The Investigator /institution should retain subject identifiers for at least 15 years after the completion or discontinuation of the study. Subject files and other source data must be kept for the maximum period of time permitted by the hospital, institution or private practice, but not less than 15 years. These documents should be retained for a longer period, however, if required by the applicable regulatory requirements or by a BioMarin agreement. BioMarin must be notified and will assist with retention should Investigator /institution be unable to continue maintenance of subject files for the full 15 years. It is the responsibility of BioMarin to inform the Investigator /institution as to when these documents no longer need to be retained.



## **20 USE OF INFORMATION AND PUBLICATION**

BioMarin recognizes the importance of communicating medical study data and therefore encourages the publication of these data in reputable, peer-reviewed scientific journals and at seminars or conferences. The details of the processes of producing and reviewing reports, manuscripts, and presentations based on the data from this study will be described in the Clinical Trial Agreement between BioMarin and the Investigator/Institution. Consideration for authorship of all publications will be based on compliance with the Uniform Requirements for Manuscripts Submitted to Biomedical Journals (“Uniform Requirements”) of the International Committee of Medical Journal Editors (ICMJE) ([http://www.icmje.org/ethical\\_1author.html](http://www.icmje.org/ethical_1author.html)) and good publication practices (GPP).

---

## 21 REFERENCES

Batts KP & Ludwig J. Chronic hepatitis: an update on terminology and reporting. *Am J Surg Pathol* 19:1409-1417. 1995.

Bedossa P, Pynard T, French METAVIR Cooperative Study Group. An algorithm for grading activity in chronic hepatitis C. *Hepatology* 24:289-293. 1996.

Berntorp E, Dolan G, Hay C, Linari S et al. European retrospective study of real-life haemophilia treatment. *Haemophilia*. 2017;23(1):105-114.

Berntorp, E, Peake, I, Budde, U, Laffan, M et. al. von Willebrand's disease: a report from a meeting in the Aland islands. *Haemophilia* 18 Suppl 6, 1-13. 2012.

Brooks R. EuroQol: the current state of play. *Health Policy*. 1996;37:53-72.

Chai-Adisaksopha C, Skinner M, Curtis R, et al. Psychometric Properties of the Patient Reported Outcomes, Burdens and Experiences (PROBE) Questionnaire. *Blood*. 2017;130:5645.

EuroQol Group. EuroQol – a new facility for the measurement of health-related quality of life. *Health Policy*. 1990;16:199-208.

George, LA, Sullivan, S, Teitel, J, Cuker, A et al. Preliminary results of a phase 1/2 trial of SPK-9001, a hyperactive FIX variant delivered by a novel capsid, demonstrate consistent factor IX activity levels at the lowest dose cohort. *Haemophilia* 22[Suppl. 4], 151-152. 2016.

Hay, CR, DiMichele, DM. The principal results of the International Immune Tolerance Study: a randomized dose comparison  
12. *Blood* 119[6], 1335-1344. 2012.

Haemo-QoL Study Group. Scoring Manual. Available at: <http://haemoqol.de/scoring/manual>. Last accessed 28 July 2017.

Kaufman, RJ, Powell, JS. Molecular approaches for improved clotting factors for hemophilia 1. *Blood* 122[22], 3568-3574. 2013.

Manno, CS, Pierce, GF, Arruda, VR, Glader, B et. al. Successful transduction of liver in hemophilia by AAV-Factor IX and limitations imposed by the host immune response. *Nat Med* 12[3], 342-347. 2006.



Miesbach, W, Tangelder, M, Klamroth, R, Schutgens, R et al. Updated results from a dose escalating study in adult patients with haemophilia B with AMT-060 (AAV5-hFIX) gene therapy. *Haemophilia* 22[Suppl. 4], 151-152. 2016.

Mingozzi, F and High, KA. Immune responses to AAV vectors: overcoming barriers to successful gene therapy. *Blood* 122[1], 23-36. 2013.

Nathwani, AC, Reiss, UM, Tuddenham, EG, Rosales, C et. al. Long-term safety and efficacy of factor IX gene therapy in hemophilia B. *N Engl J Med* 371[21], 1994-2004. 2014.

Nathwani, AC, Rosales, C, McIntosh, J, Rastegarlar, G et. al. Long-term safety and efficacy following systemic administration of a self-complementary AAV vector encoding human FIX pseudotyped with serotype 5 and 8 capsid proteins. *Mol Ther* 19[5], 876-885. 2011.

Nathwani, AC, Tuddenham, EG. Epidemiology of coagulation disorders. *Baillieres Clin Haematol* 5[2], 383-439. 1992.

Pasi, KJ, Rangarajan, S, Kim, B, et al. Achievement of Normal Circulating Factor VIII Activity Following BMN 270 AAV5-FVIII Gene Transfer: Interim, Long-Term Efficacy and Safety Results from a Phase 1/2 Study in Patients with Severe Hemophilia A. *Blood* 130[Suppl. 1], 603. 2017.

Reilly, M. WPAI Scoring. 2002. Available at: [http://www.reillyassociates.net/WPAI\\_Scoring.html](http://www.reillyassociates.net/WPAI_Scoring.html). Last accessed 28 July 2017.

Recht M, Neufeld EJ, Sharma VR, Solem CT et al. Impact of Acute Bleeding on Daily Activities of Patients with Congenital Hemophilia with Inhibitors and Their Caregivers and Families: Observations from the Dosing Observational Study in Hemophilia (DOSE). *Value in Health*. 2014;17:744-748.

Rentz A, Flood E, Altisent C, Bullinger M et al. Cross-cultural development and psychometric evaluation of a patient-reported health-related quality of life questionnaire for adults with haemophilia. *Haemophilia* 2008;14(5):1023-34.

Sampson HA, Muñoz-Furlong A, Campbell RL, et al. Second symposium on the definition and management of anaphylaxis: summary report—second National Institute of Allergy and Infectious Disease/Food Allergy and Anaphylaxis Network symposium. *J Allergy Clin Immunol* 2006;117:391-397.

Srivastava, A, Brewer, AK, Mauser-Bunschoten, EP, Key, NS et. al. Guidelines for the management of hemophilia 128. *Haemophilia* 19[1], e1-47. 2013.



Stonebraker, JS, Brooker, M, Amand, RE, Farrugia, A et. al. A study of reported factor VIII use around the world. *Haemophilia* 16[1], 33-46. 2010.

United States Department of Health and Human Services. Guidelines for the Use of Antiretroviral Agents in HIV-1-Infected Adults and Adolescents. 2014. Available at <https://aidsinfo.nih.gov/guidelines/html/1/adult-and-adolescent-arv-guidelines/458/plasma-hiv-1-rna--viral-load--and-cd4-count-monitoring>. Last accessed 28 July 2017.

Van Genderen FR, Westers P, Heijnen L, De Kleijn P et al. Measuring patients' perceptions on their functional abilities: validation of the Haemophilia Activities List. *Haemophilia*. 2006;12:36-46.

Wiens BL, Dmitrienko A. The fallback procedure for evaluating a single family of hypotheses. *J Biopharm Stat*. 2005; 15:929–942.



## **22 INVESTIGATOR RESPONSIBILITIES**

### **22.1 Conduct of Study and Protection of Human Patients**

In accordance with FDA Form 1572 and/or principles of ICH E6 GCP, the Investigator will ensure that:

- He or she will conduct the study in accordance with the relevant, current protocol and will only make changes in a protocol after notifying the sponsor, except when necessary to protect the safety, rights, or welfare of subjects.
- He or she will personally conduct or supervise the study.
- He or she will inform any potential subjects, or any persons used as controls, that the drugs are being used for investigational purposes, and he or she will ensure that the requirements relating to obtaining informed consent in 21 CFR Part 50 and/or ICH E6 sections 2.9 and 4.8 are met. As well, he or she will ensure that IRB/IEC review and approval in 21 CFR Part 56 and/or ICH E6 section 2.6 are met.
- He or she will report to the sponsor adverse experiences that occur in the course of the investigation in accordance with 21 CFR 312.64 and/or ICH E6 Section 4.11.
- He or she has read and understands the information in the Investigator's Brochure, including potential risks and side effects of the drug.
- His or her staff and all persons who assist in the conduct of the study are informed about their obligations in meeting the above commitments
- Adequate and accurate records in accordance with 21 CFR 312.62 and/or ICH E6 section 4.9 are kept, and those records are available for inspection in accordance with 21 CFR 312.68 and/or ICH E6 section 4.9.7.
- The IRB/EC/REB complies with the requirements of 21 CFR Part 56, ICH E6 Section 3.0, and other applicable regulations, and conducts initial and ongoing reviews and approvals of the study. He or she will also ensure that any change in research activity and all problems involving risks to human subjects or others are reported to the IRB/EC/REB. Additionally, he or she will not make any changes in the research without IRB/EC/REB approval, except where necessary to eliminate apparent immediate hazards to human subjects.
- He or she agrees to comply with all other requirements regarding the obligations of clinical Investigators and all other pertinent requirements in 21 CFR Part 312 and/or ICH E6.



**23 SIGNATURE PAGE**

**Protocol Title:** A Phase 3 Open-Label, Single Arm Study To Evaluate The Efficacy and Safety of BMN 270, an Adeno-Associated Virus Vector-Mediated Gene Transfer of Human Factor VIII in Hemophilia A Patients with Residual FVIII Levels  $\leq$  1 IU/dL Receiving Prophylactic FVIII Infusions

**Protocol Number:** 270-301 Amendment 2

I have read the forgoing protocol and agree to conduct this study as outlined. I agree to conduct the study in compliance with all applicable regulations and guidelines, including ICH E6, as stated in the protocol, and other information supplied to me.

Investigator Signature \_\_\_\_\_ Date \_\_\_\_\_

Printed name: \_\_\_\_\_

Accepted for the Sponsor:

**PI** 

Medical Monitor Signature \_\_\_\_\_ Date \_\_\_\_\_

Printed name: **PI**  Clinical Sciences



---

**24 APPENDIX 1: SAMPSON'S ANAPHYLAXIS CRITERIA**

According to the National Institute of Allergy and Infectious Disease/Food Allergy and Anaphylaxis Network (NIAID/FAAN) Second Symposium on the definition and management of anaphylaxis, anaphylaxis is highly likely when any one of the following 3 criteria are fulfilled:

1. Acute onset of an illness (minutes to several hours) with involvement of the skin, mucosal tissue, or both (eg, generalized hives, pruritus or flushing, swollen lips-tongue-uvula)  
*AND AT LEAST ONE OF THE FOLLOWING*
  - a. Respiratory compromise (eg, dyspnea, wheeze-bronchospasm, stridor, reduced peak expiratory flow [PEF], hypoxemia)
  - b. Reduced blood pressure (BP) or associated symptoms of end-organ dysfunction (eg, hypotonia [collapse], syncope, incontinence)
2. Two or more of the following that occur rapidly after exposure to a likely allergen for that patient (minutes to several hours):
  - c. Involvement of the skin-mucosal tissue (eg, generalized hives, itch-flush, swollen lips-tongue-uvula)
  - d. Respiratory compromise (eg, dyspnea, wheeze-bronchospasm, stridor, reduced PEF, hypoxemia)
  - e. Reduced BP or associated symptoms (eg, hypotonia [collapse], syncope, incontinence)
  - f. Persistent gastrointestinal symptoms (eg, crampy abdominal pain, vomiting)
3. Reduced BP after exposure to known allergen for that patient (minutes to several hours):
  - g. Infants and children: low systolic blood pressure (age specific) or greater than 30% decrease in systolic BP
  - h. Adults: systolic BP of less than 90 mmHg or greater than 30% decrease from that person's baseline.

Source: [Sampson, 2006](#).





## 25 PROTOCOL AMENDMENT TEXT REVISIONS

The following table summarizes the revisions made to the protocol and relates the changes to the appropriate rationale (see pages 2-4). Added text is indicated by underlined font and deleted text is indicated by ~~strike through~~ font.

| Section No./Title                | Revision  | Rationale |
|----------------------------------|---|-----------|
| Synopsis (Study Sites)           | Approximately <del>4060</del> sites worldwide.  | 1         |
| Synopsis (Study Rationale)       | <p><u>The vector schematic was updated</u></p> <p>The current study is a Phase 3, single-arm, open-label study designed to assess whether, in an expanded sample, BMN 270 can safely alter the clinical phenotype of hemophilia A patients with residual FVIII activity <math>\leq 1</math> IU/dL, <del>with an altered phenotype defined as achieving FVIII activity of <math>&gt; 15\%</math> (<math>\geq 15</math> IU/dL).</del></p>   | 15, 16    |
| Synopsis (Study Design and Plan) | <p>This is a Phase 3, single-arm, open-label study in hemophilia A patients with residual FVIII levels <math>\leq 1</math> IU/dL treated continuously with prophylactic exogenous FVIII for a minimum of one year prior to enrollment. Subjects will be enrolled at approximately <del>4060</del> sites worldwide. Subjects must have high-quality, well-documented historical data available concerning previous bleeding episodes and exogenous FVIII usage over the previous 12 months in order to be eligible to enroll in the study.</p> <p>Approximately <del>70130</del> adult subjects with severe HA will receive a 6E13 vg/kg dose of BMN 270 as a single intravenous infusion. Approximately 20 subjects will enroll in the study with at least 12 months of well-documented high-quality historical data concerning previous bleeding episodes and exogenous FVIII usage, while approximately <del>50110</del> subjects will enroll in the study after having completed <del>at least</del> <u>approximately</u> 6 months' participation in the BioMarin-sponsored non-interventional study 270-902.</p> <p><u>The study schematic has been updated</u></p> <p>The Data Monitoring Committee (DMC) will review available safety and efficacy (eg, FVIII activity) data during the study on an ongoing basis and may determine, based on emerging data and the risk/benefit profile, that further enrollment at 6E13 vg/kg should be discontinued in favor of a different dose of BMN 270, not to exceed 6E13 vg/kg. If the DMC recommends a dosing modification, then additional subjects may be enrolled, up to a total of approximately <del>70130</del> subjects, at the new BMN 270 dose level (regardless of the number of subjects previously enrolled at 6E13 vg/kg).</p> <p>...</p> | 1, 16     |



| Section No./Title                           | Revision  | Rationale   |
|---|---|-------------|
|   | <p>Throughout the study, subjects with FVIII activity below 5 IU/dL may be monitored more frequently at the discretion of the Medical Monitor and the Investigator. In subjects who show an initial response to BMN 270 but who later have FVIII activity decline to &lt; 5 IU/dL, the investigator and Medical Monitor will review the subject's FVIII activity <del>levels</del> <u>level trends (not specific FVIII activity levels)</u> and discuss whether to resume prior FVIII prophylaxis. In addition, the investigator will notify the subject of his FVIII activity levels and will discuss with the subject the risk of bleeding and when (and if) prior FVIII prophylaxis will be resumed.</p> <p>There will be an ongoing review of individual subject safety <u>by the Medical Monitor</u>, and <u>both safety and efficacy data</u> by the <del>Medical Monitor and the</del> DMC. FVIII activity by a validated assay will be used to evaluate efficacy over the course of the study. Therapeutic oral corticosteroids may be initiated when a subject's ALT values are elevated or based on review of FVIII activity and liver enzyme data, and subsequent dosage adjustments made, after consultation between the Investigator and the Medical Monitor.</p>  |             |
| Synopsis (Number of Subjects Planned)       | Approximately <del>70</del> <u>130</u> subjects may enroll into the study.  | 1           |
| Synopsis (Inclusion and Exclusion Criteria) | <p>Patients are eligible to be included in the study only if all of the following criteria apply:</p> <p>5. No <u>previous documented</u> history of a <u>detectable</u> FVIII inhibitor, and results from a Bethesda assay <u>or Bethesda assay with Nijmegen modification of less than 0.6 Bethesda Units (BU) (or less than 1.0 BU for laboratories with a historical lower sensitivity cutoff for inhibitor detection of 1.0 BU)</u> on 2 consecutive occasions <u>(at least one week apart within the most recent past 12 months (at least one of which should be tested at the central laboratory))</u> <del>at least one week apart within the past 12 months</del>.</p> <p>6. Sexually active participants must agree to use an acceptable method of effective contraception <del>---, either double-barrier</del> contraception (ie, condom + diaphragm; or condom or diaphragm + spermicidal gel or foam) or their female partner either using hormonal contraceptives or having an intrauterine device <del>---</del>. <u>Participants must agree to contraception use for at least 6 months</u> <del>12 weeks</del> post-infusion. <del>After 6 months;</del> <u>after 12 weeks</u>, subjects may stop contraception use only if they have had 3 consecutive semen samples with no detectable viral vector DNA.</p> <p>8. HIV positive patients may be enrolled, only if the patient has a CD4 count &gt; 200/mm<sup>3</sup> and an undetectable viral load <u>(unquantifiable viral load as defined as less than the limit of quantification by the testing laboratory's assay is permitted)</u>.</p> <p>Patients are excluded from the study if any of the following criteria apply:</p> <p>3. Significant liver dysfunction with any of the following abnormal laboratory results:</p> | 4, 5, 9, 13 |



| Section No./Title                  | Revision  | Rationale |
|------------------------------------|---|-----------|
|                                    | <ul style="list-style-type: none"> <li>• ALT (alanine transaminase) or AST &gt;2X ULN;</li> <li>• Total bilirubin &gt;2X ULN;</li> <li>• Alkaline phosphatase &gt;2X ULN; or</li> <li>• INR (international normalized ratio) <math>\geq</math> 1.4.</li> </ul> <p>Subjects whose liver laboratory assessments fall outside of these ranges may undergo repeat testing and, if eligibility criteria are met on retest, may be enrolled after confirmation by the Medical Monitor. In addition, subjects with abnormal laboratory results related to confirmed benign liver conditions (<del>eg, Gilbert's syndrome</del>) are considered eligible for the study notwithstanding their abnormal laboratory results and may be enrolled after discussion with the Medical Monitor.</p> <ul style="list-style-type: none"> <li>• <u>Benign liver conditions are those conditions (eg, Gilbert's syndrome) where physiologic hepatic findings can be considered non-serious in nature and do not confer illness or in most instances require treatment. Individuals with such conditions that do not impact laboratory values such as serum transaminases or conjugated bilirubin (eg, Gilbert's syndrome) and enable assessment of potential liver toxicity following BMN 270 infusion may be included in the study following a review by the Medical Monitor.</u></li> </ul> <p>9. Chronic or active hepatitis B as evidenced by positive serology testing (<u>hepatitis B surface antigen [HBsAg], hepatitis B surface antibody [HBsAb], and hepatitis B core antibody [HBcAb]</u>) and confirmatory HBV DNA testing. Refer to the Centers for Disease Control (CDC) table for the interpretation of serological test results in the Laboratory Manual.</p> |           |
| Synopsis (Criteria for Evaluation) | <p>Secondary efficacy endpoints:</p> <ul style="list-style-type: none"> <li>• Change in the annualized utilization (IU/kg) of exogenous FVIII replacement therapy during Week 5 to Week 52 post-BMN 270 infusion from the baseline utilization of exogenous FVIII replacement therapy <del>calculated using subjects' historical medical records during the year prior to enrollment.</del></li> <li>• Change in the annualized number of bleeding episodes requiring exogenous FVIII replacement treatment (annualized bleeding rate, ABR) during Week 5 to Week 52 of the study post-BMN 270 infusion from the baseline ABR <del>calculated using subjects' historical medical records during the year prior to enrollment.</del></li> </ul>  | 2         |
| Synopsis (Statistical Methods)     | <u>Sample Size</u>  | 2         |



| Section No./Title | Revision   | Rationale |
|-------------------|--|-----------|
|                   | <p><del>Seventy (70)</del> <u>One hundred and thirty (130)</u> subjects may be dosed in the study. The sample size for this study is based on clinical and statistical considerations in order to provide sufficient data to assess both safety and efficacy of BMN 270.</p> <p>For the <u>primary endpoint</u>, a sample size of <del>70</del><u>130</u> will provide at least 95% power to demonstrate that the change in hFVIII activity during Weeks 49-52 from baseline is greater than 0, assuming an effect size of 0.6, using a one-sample t-test with a 2-sided significance level of <del>0.025</del><u>0.05</u>.</p> <p><del>A sample size of 70</del> <u>For the secondary endpoints, the analyses will be performed utilizing exogenous FVIII use and bleeding episode data from the 110 subjects whose baseline data will be prospectively collected for approximately 6 months in the non-interventional study 270-902, prior to their enrollment in 270-301. An analytic sample size of 110 will provide at least 95% power to demonstrate that the change in the annualized utilization (IU/kg) of exogenous FVIII replacement therapy during Week 5 to Week 52 post-BMN 270 infusion from baseline is less than 0, assuming an effect size of 0.6, using a one-sample t-test with a 2-sided significance level of <del>0.025</del><u>0.05</u>.</u></p> <p><del>An analytic sample size of 70</del><u>110</u> will also have at least 95% power to demonstrate that the change in the annualized number of bleeding episodes requiring exogenous FVIII replacement treatment (ABR) during Week 5 to Week 52 of the study post-BMN 270 infusion from the baseline ABR is less than 3.5 (non-inferiority margin), assuming the pre- and post-BMN 270 infusion population mean ABRs are 3.5 and 1 respectively, using a one-sample t-test with a 2-sided significance level of <del>0.025</del><u>0.05</u>. Under the same assumptions, a sample size of <del>70</del><u>110</u> will have approximately 90% power to demonstrate that the change is less than 0, i.e. superiority of BMN 270 against FVIII prophylaxis.</p> <p>Overall, <del>at the planned sample size of 70</del> <u>the planned sample size of 130</u> will have greater than 80% power for testing the primary and secondary efficacy endpoints hierarchically <del>at the final analysis</del> with a 2-sided significance level of <del>0.025</del><u>0.05</u>.</p> <p><u>Analysis</u></p> <p>For the primary efficacy endpoint at Week 52 (ie, the change in the hFVIII activity during Weeks 49-52 post-BMN 270 infusion from baseline, as measured by one-stage clotting assay), a one-sample t-test will be used to test the null hypothesis that the change is 0 or less against the alternative hypothesis that the change is greater than 0. Descriptive summaries of the proportions of subjects whose FVIII activity during Weeks 49-52 is greater than or equal to select thresholds, such as 15, 25 and 30 IU/dL, and the confidence intervals of the proportions will also be provided. The FVIII activity as measured by chromogenic assay will be analyzed similarly, as a supportive analysis. <u>The analyses for the primary endpoint will be performed using the efficacy analysis set.</u></p> |           |



| Section No./Title   | Revision  | Rationale |
|---------------------|---|-----------|
|                     | <p><u>For the secondary endpoints, the analyses will be performed on 110 subjects in the efficacy analysis set whose baseline data will be prospectively collected for approximately 6 months in the non-interventional study 270-902 prior to their enrollment in 270-301.</u></p> <p>...</p> <p>For the second secondary efficacy endpoint at Week 52 (ie, the change in the annualized number of bleeding episodes requiring exogenous FVIII replacement treatment during Weeks 5-52 post-BMN 270 infusion from baseline), a one-sample t-test will be performed to test for non-inferiority of BMN 270 against FVIII prophylaxis (ie, the baseline ABR calculated using subjects' <del>historical medical records during the year prior to enrollment</del> data collected in Study 270-902) using a margin of 3.5, i.e. to test the null hypothesis that the change is 3.5 or greater against the alternative hypothesis that the change is less than 3.5. If non-inferiority is demonstrated, the test for superiority of BMN 270 against FVIII prophylaxis will be performed.</p> <p>The primary efficacy endpoint and secondary efficacy endpoints will be tested hierarchically <del>at the final analysis at Week 52</del> according to the order described above.</p> <p>An interim analysis is planned after 20 treated subjects have completed the Week 26 visit (or have discontinued study participation prior to Week 26). The primary efficacy endpoint for the interim analysis is change in the hFVIII activity, as measured by one-stage clotting assay, during Weeks 23-26 post-BMN 270 infusion from baseline. Each subject's hFVIII activity during Weeks 23-26 is defined as the median of the values obtained during this 4-week window. <del>Values for hFVIII activity will be excluded if obtained within 72 hours since the last infusion of exogenous FVIII protein concentrates.</del> A 2-sided one-sample t-test will be used to test the null hypothesis that the change is 0 or less against the alternative hypothesis that the change is greater than 0. In addition, subjects' hFVIII activity post-Week 23, defined as the median of the values obtained from Week 23 to the time of last follow-up, will be analyzed similarly as an important sensitivity analysis, utilizing additional data beyond Week 26.</p> <p>...</p> <p>The <del>Hochberg fallback</del> procedure will be used to adjust for multiplicity of the interim analysis at Week 26 and the final analysis at Week 52 of the primary efficacy endpoint. (Regardless of the interim analysis results, the study <del>willis</del> <u>planned to continue upon the DMC's recommendation</u>, and the final analysis will be performed at Week 52.) At the final analysis at Week 52, the secondary efficacy endpoints will be tested hierarchically; <del>the level of significance will be determined by the truncated Hochberg procedure for parallel gatekeeping.</del></p> |           |
| 7.3/Study Rationale | <u>The vector schematic was updated</u>   | 15, 16    |



| Section No./Title                 | Revision   | Rationale |
|-----------------------------------|--|-----------|
|                                   | The current study is a Phase 3, single-arm, open-label study designed to assess whether, in an expanded sample, BMN 270 can safely alter the clinical phenotype of hemophilia A patients with residual FVIII activity $\leq 1$ IU/dL, <del>with an altered phenotype defined as reaching FVIII activity of <math>&gt; 15\%</math> (<math>&gt; 15</math> IU/dL).</del>  |           |
| 7.4/Summary of Risks and Benefits | <u>As with any infused biological product, there is a potential risk of acute, systemic hypersensitivity reactions (including anaphylaxis) with BMN 270. No hypersensitivity reactions were observed during dosing of BMN 270 in the 270-201 clinical study, although one SAE of pyrexia was reported approximately 16 hours after the infusion in a subject in the 4E13 vg/kg cohort. The subject was treated with acetaminophen, and the fever resolved within 48 hours (see Investigator's Brochure for full details). Infusion-related reactions, including allergic reaction, maculopapular rash, and presyncope, have been reported from ongoing, actively dosing clinical studies of BMN 270, including this study. All of the infusion-related reactions were effectively managed clinically and resolved without any clinical sequelae. Refer to the Investigator's Brochure for additional details.</u>  | 3         |
| 9.1/Overall Study Design and Plan | <p>This is a Phase 3, single-arm, open-label study in hemophilia A patients with residual FVIII levels <math>\leq 1</math> IU/dL treated continuously with prophylactic exogenous FVIII for a minimum of one year prior to enrollment. Subjects will be enrolled at approximately <del>4060</del> sites worldwide. Subjects must have high-quality, well-documented historical data available concerning previous bleeding episodes and exogenous FVIII usage over the previous 12 months in order to be eligible to enroll in the study.</p> <p>Approximately <del>70130</del> adult subjects with severe HA will receive a 6E13 vg/kg dose of BMN 270 as a single intravenous infusion. Approximately 20 subjects will enroll in the study with at least 12 months of well-documented high-quality historical data concerning previous bleeding episodes and exogenous FVIII usage, while approximately <del>50110</del> subjects will enroll in the study after having completed <del>at least</del> <u>approximately</u> 6 months' participation in the BioMarin-sponsored non-interventional study 270-902.</p> <p><u>The study schematic has been updated</u></p> <p>The Data Monitoring Committee (DMC) will review available safety and efficacy (eg, FVIII activity) data during the study on an ongoing basis and may determine, based on emerging data and the risk/benefit profile, that further enrollment at 6E13 vg/kg should be discontinued in favor of a different dose of BMN 270, not to exceed 6E13 vg/kg. If the DMC</p> | 1, 16     |



| Section No./Title                        | Revision   | Rationale    |
|--|--|--------------|
|  | <p>recommends a dosing modification, then additional subjects may be enrolled, up to a total of approximately <del>70</del><u>130</u> subjects, at the new BMN 270 dose level (regardless of the number of subjects previously enrolled at 6E13 vg/kg).</p> <p>...</p> <p>Throughout the study, subjects with FVIII activity below 5 IU/dL may be monitored more frequently at the discretion of the Medical Monitor and the Investigator. In subjects who show an initial response to BMN 270 but who later have FVIII activity decline to &lt; 5 IU/dL, the investigator and Medical Monitor will review the subject's FVIII activity <u>level trends</u> (<u>not specific FVIII activity levels</u>) and discuss whether to resume prior FVIII prophylaxis. In addition, the investigator will notify the subject of his FVIII activity levels and will discuss with the subject the risk of bleeding and when (and if) prior FVIII prophylaxis will be resumed.</p> <p>There will be an ongoing review of individual subject safety and efficacy data by the Medical Monitor and the DMC. FVIII activity by a validated assay will be used to evaluate efficacy over the course of the study. Therapeutic oral corticosteroids may be initiated when a subject's ALT values are elevated or based on review of FVIII activity and liver enzyme data, and subsequent dosage adjustments made, after consultation between the Investigator and the Medical Monitor. Management of ALT elevations is discussed in more detail in Section 9.7.8.3.</p> <p>There will be an ongoing review of individual subject safety <u>by the Medical Monitor</u>, and <u>both safety and efficacy data by the Medical Monitor and the DMC</u>. FVIII activity by a validated assay will be used to evaluate efficacy over the course of the study. Therapeutic oral corticosteroids may be initiated when a subject's ALT values are elevated or based on review of FVIII activity and liver enzyme data, and subsequent dosage adjustments made, after consultation between the Investigator and the Medical Monitor.</p> |              |
| Schedules of Events (Tables 9.1.1-9.1.4) | <u>The Schedules of Events have been updated consistent with changes made elsewhere in the protocol.</u>   | 10, 11       |
| Table 9.1.1 (Footnotes)                  | <sup>d</sup> Patients with documented negative results within the last 30 days do not need to be retested. <u>Hepatitis B screening should include hepatitis B surface antigen (HBsAg), hepatitis B surface antibody (HBsAb), and hepatitis B core antibody (HBcAb).</u>   | 3, 7, 12, 13 |





| Section No./Title       | Revision   | Rationale |
|-------------------------|--|-----------|
|                         | <p><sup>g</sup> Blood samples will be collected to evaluate biochemical, molecular, cellular, <u>ABO blood typing</u>, and genetic/genomic aspects relevant to hemophilia A, coagulation, and/or AAV gene transfer, and to develop assays used for these evaluations. Subjects may choose to opt out of the exploratory genetic/genomic research being done to study or try to discover genes that are not yet known to be associated with hemophilia A. While exploratory samples will be collected at the time points indicated above, testing of these samples (including those for TGA assay, Direct Thrombin Activity test, and any other exploratory assessments) will be performed only as deemed necessary by the Sponsor.</p> <p><sup>k</sup> With the exception of the collection of samples for PCR vector DNA analysis, assessments on the day of infusion must be performed prior to the infusion. <u>Subjects will fast for at least 8 hours prior to pre-infusion laboratory sampling on the day of the infusion visit.</u> On the day of the BMN 270 Infusion, vital signs will be monitored prior to the infusion, during the infusion every 15 minutes (<math>\pm</math> 5 minutes), and following the infusion hourly (<math>\pm</math> 5 minutes) for at least 8 hours during the subject's stay in the clinic. Shedding samples for PCR of vector DNA analysis (blood, saliva, urine, semen, stool) should be collected between 2 and 24 hours after the infusion has been completed.</p> <p><sup>m</sup><u>In case of hypersensitivity or adverse drug reaction, safety assessment, including physical examination and vital signs, will be done and additional blood samples will be collected within 1 hour of the hypersensitivity reaction (eg, tryptase, C3, C3a, C4, C5, and C5a, as well as possible additional exploratory testing) and one sample for IgE (and possible additional exploratory testing) between 8-24 hours after the reaction, if possible. In-patient observation can be extended and additional blood samples can be collected if deemed necessary at the discretion of the Investigator and Medical Monitor.</u></p> |           |
| Table 9.1.2 (Footnotes) | <p><sup>f</sup> <u>Testing for reactivation of hepatitis B and hepatitis C at Week 16, for subjects with a past medical history of hepatitis B or hepatitis C prior to study entry,</u> should be performed only in subjects <del>with evidence of prior exposure and</del> who have not received therapeutic oral corticosteroids prior to Week 16; subjects who have received therapeutic oral corticosteroids will have hepatitis B and hepatitis C testing at the time points indicated in <a href="#">Table 9.1.5</a>.</p>  | 16        |
| Table 9.1.4 (Footnotes) | <p><sup>*</sup> Visit windows are <math>\pm</math> 48 hours through Week 36, then <math>\pm</math>1 week until Week 52 and <math>\pm</math> 2 weeks for visits in Years 2-5. For LFT and FVIII testing during Years 2-5, the visit windows are every 4 weeks (+ 2 weeks, or to align with the Q3M visits) during Year 2, and every 6 weeks (<math>\pm</math>2 weeks) during Years 3-5. <u>At applicable sites, the Q4W (during Year 2) and Q6W (during Years 3-5) assessments may be conducted by a trained mobile nursing (MN) professional at the subject's</u></p>  | 6, 11     |





| Section No./Title                 | Revision  | Rationale |
|-----------------------------------|---|-----------|
|                                   | <p><u>home or another suitable location, if the subject has given written informed consent to participate in mobile nursing visits. Q3M visits during Years 2-5 cannot be done by a MN professional and must be done at the study site.</u></p> <p><sup>d</sup> Sample testing during Long-Term Follow-Up is not required if at least 3 consecutive samples were negative during the Post-Infusion Follow-Up period. Subjects who have not had 3 consecutive negative semen samples by Week 52 should continue to have PCR testing of semen every 4 weeks (during Year 2) or every 6 weeks (during Years 3-5) until 3 consecutive negative samples are documented (or upon consultation between the Investigator and Medical Monitor).</p>  |           |
| Table 9.1.5 (Footnotes)           | <sup>d</sup> Should only be performed in subjects with a history of hepatitis B or hepatitis C <u>prior to study entry.</u>   | 16        |
| 9.2/Discussion of Study Design    | Approximately <del>70</del> <u>130</u> subjects will be enrolled at the 6E13 vg/kg BMN 270 dose.  | 1         |
| 9.3/Selection of Study Population | Approximately <del>70</del> <u>130</u> adult hemophilia A patients with residual FVIII levels $\leq$ 1 IU/dL may enroll into the study.   | 1         |
| 9.3.1/Inclusion Criteria          | <p>5. No <u>previous documented</u> history of a <u>detectable</u> FVIII inhibitor, and results from a Bethesda assay or <u>Bethesda assay</u> with Nijmegen modification of less than 0.6 Bethesda Units (BU) (or <u>less than 1.0 BU for laboratories with a historical lower sensitivity cutoff for inhibitor detection of 1.0 BU</u>) on 2 consecutive occasions (<del>at least one week apart within the most recent past 12 months (at least one of which should be tested at the central laboratory)</del><u>at least one week apart within the past 12 months</u>).</p> <p>6. Sexually active participants must agree to use an acceptable method of effective contraception<del>---, either double-barrier</del> contraception (ie, condom + diaphragm; or condom or diaphragm + spermicidal gel or foam) or their female partner either using hormonal contraceptives or having an intrauterine device<del>---</del>. <u>Participants must agree to contraception use for at least 6 months/12 weeks post-infusion. After 6 months; after 12 weeks,</u> subjects may stop contraception use only if they have had 3 consecutive semen samples with no detectable viral vector DNA.</p> <p>8. HIV positive patients may be enrolled, only if the patient has a CD4 count &gt; 200/mm<sup>3</sup> and an undetectable viral load (<u>unquantifiable viral load as defined as less than the limit of quantification by the testing laboratory's assay is permitted</u>).</p> | 4, 5, 9   |
| 9.3.2/Exclusion Criteria          | <p>3. Significant liver dysfunction with any of the following abnormal laboratory results:</p> <ul style="list-style-type: none"> <li>• ALT (alanine transaminase) or AST &gt;2X ULN;</li> <li>• Total bilirubin &gt;2X ULN;</li> </ul>   | 13        |



| Section No./Title                             | Revision  | Rationale |
|---|---|-----------|
|   | <ul style="list-style-type: none"> <li>• Alkaline phosphatase &gt;2X ULN; or</li> <li>• INR (international normalized ratio) <math>\geq</math> 1.4.</li> </ul> <p>Subjects whose liver laboratory assessments fall outside of these ranges may undergo repeat testing and, if eligibility criteria are met on retest, may be enrolled after confirmation by the Medical Monitor. In addition, subjects with abnormal laboratory results related to confirmed benign liver conditions (<del>eg, Gilbert's syndrome</del>) are considered eligible for the study notwithstanding their abnormal laboratory results and may be enrolled after discussion with the Medical Monitor.</p> <ul style="list-style-type: none"> <li>• <u>Benign liver conditions are those conditions (eg, Gilbert's syndrome) where physiologic hepatic findings can be considered non-serious in nature and do not confer illness or in most instances require treatment. Individuals with such conditions that do not impact laboratory values such as serum transaminases or conjugated bilirubin (eg, Gilbert's syndrome) and enable assessment of potential liver toxicity following BMN 270 infusion may be included in the study following a review by the Medical Monitor.</u></li> </ul> <p>9. Chronic or active hepatitis B as evidenced by positive serology testing (<u>hepatitis B surface antigen [HBsAg], hepatitis B surface antibody [HBsAb], and hepatitis B core antibody [HBcAb]</u>) and confirmatory HBV DNA testing. Refer to the Centers for Disease Control (CDC) table for the interpretation of serological test results in the Laboratory Manual.</p> |           |
| 9.4.2.1/Product Characteristics and Labelling | <p>BMN 270 is a sterile, clear, colorless-to-pale yellow solution for IV infusion and is supplied in a 10 mL Crystal Zenith<sup>®</sup> (CZ) vial. Each vial contains 8.5 mL (<u>extractable volume 8 mL</u>) of AAV5-hFVIII-SQ at a concentration of 2E13 vector genomes per mL in a pH 7.4 phosphate buffer.</p> <p><del>Labelling follows country specific requirements.</del> <u>The study drug is labelled according to the particulars approved by the relevant regulatory agencies.</u></p>  | 16        |
| 9.4.4/Directions for Administration           | <p><del>After</del> <u>On the day of infusion, the subject will come to the infusion site, where a physical examination will be performed by the Investigator or designee, subjects will be admitted on the day of BMN 270 infusion.</u> If the subject is found to have an active acute illness at the time of planned infusion, then the infusion should be deferred until the illness has resolved; screening procedures may require repetition if outside the specified window. An IV catheter <u>or butterfly needle</u> will be inserted into a suitable peripheral vein (eg, the median cubital vein) and flushed with saline. FVIII replacement therapy will not be given since venipuncture is a minimally invasive procedure in these individuals under ordinary conditions.</p>  | 3, 8, 16  |



| Section No./Title | Revision   | Rationale |
|-------------------|--|-----------|
|                   | <p>BMN 270 will be prepared and infused as a pure solution over a dose-dependent time. Prepared drug will be kept at room temperature prior to administration. An electric syringe pump will be used to infuse through an in-line, low protein binding 0.22 micron filter. BMN 270 will be infused through the catheter using an appropriate infusion pump at a <del>constant</del> <u>an initial rate of 1 mL/min. The infusion rate should be increased every 30 minutes by 1 mL/min up to a maximum of 4 mL/min while monitoring the,</u> provided that the subject's clinical condition permits such an increase. <u>Of note, the IP has been shown to be stable at room temperature for 7.5 hours following completion of product thaw. Vital signs (pulse, blood pressure, respiration rate and temperature) should be monitored at 15 minute (±5 minutes) intervals. The anticipated maximum interval from initiation of thawing of BMN 270 to completion of the infusion is 4 hours, although the IP has been shown to be stable at room temperature for 6 hours, throughout the time period of the infusion.</u></p> <p><u>As with any infused biological product, there is a potential risk of acute, systemic hypersensitivity reactions (including anaphylaxis) with BMN 270. Dosing will be administered at a qualified infusion site, with appropriate resuscitation equipment and medication available and easily accessible.</u></p> <p><u>Clinical staff administering BMN 270 should be trained appropriately in recognizing and managing the signs and symptoms associated with potential hypersensitivity, anaphylactic, and anaphylactoid reactions. Additionally, the Investigator should be familiar with Sampson's criteria for defining anaphylaxis (Sampson, 2006; Appendix 1).</u></p> <p><u>Should symptoms of potential hypersensitivity occur, the infusion may be slowed or halted at the Investigator's discretion, with consideration of the subject's clinical condition. If the infusion is halted, it should only be restarted if the Investigator considers it safe and appropriate to do so. Antihistamines, anti-pyretic, and/or corticosteroid administration is permitted prior to restarting an interrupted infusion by an infusion-related reaction. At the restart, the infusion rate may be adjusted (ie, to a slower rate [minimum of 1 mL/min], with the rate increased every 30 minutes by 1 mL/min up to a maximum rate of 4 mL/min, if the subject's clinical condition permits such an increase) with careful monitoring of the subject.</u></p> <p><u>In case of hypersensitivity or adverse drug reaction, safety assessment, including physical examination and vital signs, will be done and additional blood samples will be collected within 1 hour of the hypersensitivity reaction (eg, tryptase, C3, C3a, C4, C5, and C5a, as well as possible additional exploratory testing) and one sample for IgE (and possible additional exploratory testing) between 8-24 hours after the reaction, if possible. In-patient observation can be extended</u></p> |           |



| Section No./Title  | Revision   | Rationale |
|--|--|-----------|
|  | <p><u>and additional blood samples can be collected if deemed necessary at the discretion of the Investigator and Medical Monitor.</u></p> <p>...</p> <p><u>Prior to discharging subjects from the clinic, the Investigator or designee should instruct subjects how to recognize signs and symptoms of potential (delayed) hypersensitivity reactions and anaphylaxis, and to contact a medical practitioner or seek emergency care in case of such an event.</u></p>         |           |
| 9.4.5/Method of Assigning Subjects to Treatment Groups                         | <p>Subjects who meet all eligibility criteria (refer to Section 9.3.1 and Section 9.3.2) may be enrolled into the study. Approval by the Medical Monitor will be required prior to enrollment of each study subject. Upon their enrollment into the study, subjects will be assigned a unique subject number <del>by the Sponsor</del>.</p> <p>Approximately <del>70</del><u>130</u> subjects will be enrolled at 6E13 vg/kg.</p>  | 1, 16     |
| 9.4.6/Selection of Dose Used in the Study                                      | <p>In order to further evaluate the dose-response relationship of BMN 270, subjects will be enrolled at a dose of 6E13 vg/kg. This dose is expected to be safe and effective based on clinical experience to date in 270-201. The DMC will review emerging safety and efficacy data and may recommend that a different dose (not to exceed 6E13 vg/kg) be administered. In such a case, up to <del>70</del><u>130</u> additional subjects may be enrolled at the new dose.</p> | 1         |
| 9.4.8.2/Therapeutic Glucocorticoid Treatment of Elevated Hepatic Transaminases | <p>Therapeutic oral corticosteroids (prednisone or converted equivalent) should be initiated when either of the following occurs post-BMN 270 infusion in any subject and after consultation with the Medical Monitor (or their designee <del>if consultation is required outside of the Medical Monitor's waking hours</del>):</p>  | 16        |
| 9.4.9/Monitoring of HIV-Positive Subjects                                      | <p>HIV-positive subjects may be enrolled in 270-301 if the subject has a CD4 count &gt; 200/mm<sup>3</sup> and an undetectable viral load (<u>unquantifiable viral load as defined as less than the limit of quantification by the testing laboratory's assay is permitted</u>).</p>   | 5         |
| 9.7.2.1/FVIII Activity   | <p>In subjects who show an initial response to BMN 270 but who later have FVIII activity decline to &lt; 5 IU/dL, the investigator and Medical Monitor will review the subject's FVIII activity <u>level trends (not specific FVIII activity levels)</u> and discuss whether to resume prior FVIII prophylaxis. In addition, the investigator will notify the subject of his FVIII</p>   | 16        |



| Section No./Title                                       | Revision  | Rationale |
|---|---|-----------|
|   | activity levels and will discuss with the subject the risk of bleeding and when (and if) prior FVIII prophylaxis will be resumed.   |           |
| 9.7.3.1/FVIII Replacement Therapy/<br>Bleeding Episodes | <p>Secondary efficacy variables are:</p> <ul style="list-style-type: none"> <li>Change in the annualized utilization (IU/kg) of exogenous FVIII replacement therapy during Week 5 to Week 52 post-BMN 270 infusion from the baseline utilization of exogenous FVIII replacement therapy <del>calculated using subjects' historical medical records during the year prior to enrollment.</del></li> <li>Change in the annualized number of bleeding episodes requiring exogenous FVIII replacement treatment (annualized bleeding rate, ABR) during Week 5 to Week 52 of the study post-BMN 270 infusion from the baseline ABR <del>calculated using subjects' historical medical records during the year prior to enrollment.</del></li> </ul>  | 2         |
| 9.7.7/Exploratory Assessments                           | Blood samples will be collected from subjects at the time points indicated in <a href="#">Table 9.1.1</a> , <a href="#">Table 9.1.2</a> , <a href="#">Table 9.1.3</a> , and <a href="#">Table 9.1.4</a> to evaluate biochemical, molecular, cellular, <u>ABO blood typing</u> , and genetic/genomic aspects relevant to hemophilia A, coagulation, and/or AAV gene transfer, and to develop assays used for these evaluations.  | 7         |
| 9.7.8.2/Clinical Laboratory Assessments                 | <p>In addition to scheduled clinical laboratory assessments, a fasting blood lipid panel (including triglycerides, total cholesterol, HDL cholesterol, and LDL cholesterol) will be assessed at the BMN 270 infusion visit. <u>Subjects will fast for at least 8 hours prior to pre-infusion laboratory sampling on the day of the infusion visit.</u></p> <p><u>In case of hypersensitivity or adverse drug reaction, safety assessment, including physical examination and vital signs, will be done and additional blood samples will be collected within 1 hour of the hypersensitivity reaction (eg, tryptase, C3, C3a, C4, C5, and C5a, as well as possible additional exploratory testing) and one sample for IgE (and possible additional exploratory testing) between 8-24 hours after the reaction.</u></p> <p><u>During Years 2-5, at applicable sites, certain study assessments may be performed by a mobile nursing (MN) professional at the patient's home or another suitable location, such as their school or office, to improve access and convenience for patients participating in the study. The Sponsor may select a healthcare company that will be responsible for providing MN services for participating sites (the MN vendor). The MN vendor is responsible for ensuring that all MN professionals are licensed, qualified, and in good standing, as per applicable regulations, and that appropriate background checks have been performed. If the investigator at a participating site determines that MN services are appropriate for a patient and the patient gives written informed consent to participate in MN visits, the MN network will communicate with</u></p> | 3, 6, 12  |



| Section No./Title                            | Revision  | Rationale |
|--|---|-----------|
|  | <u>the patient and the patient's site. MN visits will be allowed for the Q4W (during Year 2) and Q6W (during Years 3-5) visits; the Q3M visits during Years 2-5 will not be performed by an MN professional but will be done at the study site.</u>   |           |
| 9.7.8.3/Liver Function and Hepatitis Testing | <p>Subjects will be screened for evidence of previous or active hepatitis B or hepatitis C infection at Screening-; <u>hepatitis B screening should include HBsAg, HBsAb, and HBcAb.</u> Subjects with documented results showing an absence of active hepatitis B or hepatitis C infection (as measured by positive surface antigen for hepatitis B or positive RNA testing for hepatitis C) 30 days prior to providing signed informed consent do not need to repeat those tests during the screening period.</p> <p>Evidence of ongoing hepatitis B or hepatitis C infection is exclusionary. Subjects with <del>evidence</del> <u>a history of hepatitis B or hepatitis C infection prior exposure to study entry</u> will be tested for hepatitis B and hepatitis C reactivation at Week 16.</p> | 14, 16    |
| 9.7.8.6/Vector Shedding                      | Subjects who have not had 3 consecutive negative semen samples by Week 52 should continue to have PCR testing in semen every 4 weeks <u>(during Year 2) and every 6 weeks (during Years 3-5)</u> until 3 consecutive negative samples are documented (or upon consultation between the Investigator and Medical Monitor).   | 11        |
| 10.2/Serious Adverse Events                  | <p>A serious adverse event (SAE) is any untoward medical occurrence that, at any dose:</p> <ul style="list-style-type: none"> <li>Requires inpatient hospitalization or prolongation of existing hospitalization</li> </ul> <p>Note: In general, hospitalization signifies that the subject has been detained (usually involving at least an overnight stay) at the hospital or emergency ward for observation and/or treatment that would not have been appropriate in the physician's office or outpatient setting. <u>If the investigational product preparation, infusion, and post-infusion observation period require transfer to an inpatient setting for completion, in the absence of an AE, this will not be considered an SAE.</u></p>   | 14        |
| 10.2.1/EOSI                                  | <p>The following EOSI need to be reported to the Sponsor within 24 hours of site awareness, irrespective of seriousness, severity or causality:</p> <ul style="list-style-type: none"> <li><u>Systemic hypersensitivity, anaphylactic, or anaphylactoid reactions (refer to Appendix 1)</u></li> </ul>  | 3         |
| 12.2/Screening                               | The following procedures will be performed during the Screening Period:   | 13        |



| Section No./Title                              | Revision  | Rationale |
|--|---|-----------|
|  | <ul style="list-style-type: none"> <li>• Screen for Hepatitis B, Hepatitis C, and HIV if required (subjects with documented negative results 30 days prior to informed consent being obtained do not need to be retested)               <ul style="list-style-type: none"> <li>○ <u>Hepatitis B screening should include HBsAg, HBsAb, and HBcAb.</u></li> </ul> </li> </ul>  |           |
| 12.2.1/Smart Rescreening Visit                 | <p>If a patient has to be screened again because the original assessments have fallen out of the 28 + 14 day period allowed for Screening (refer to Section 12.2), then only the following assessments need to be performed (rather than the full list indicated in Section 12.2) for the patient to be successfully re-screened for the study:</p> <ul style="list-style-type: none"> <li>• <del>Blood sample for</del> AAV5 Total Antibody assay</li> </ul>   | 16        |
| 12.4/Treatment Visit/ BMN 270 Infusion (Day 1) | <p>The following procedures will be performed during the BMN 270 Infusion Visit:</p> <ul style="list-style-type: none"> <li>• Fasting lipid panel (blood triglycerides, total cholesterol, HDL cholesterol, and LDL cholesterol) (sample collected pre-infusion)               <ul style="list-style-type: none"> <li>○ <u>Subjects will fast for at least 8 hours prior to pre-infusion laboratory sampling on the day of the infusion visit.</u></li> </ul> </li> </ul> <p><u>In case of hypersensitivity or adverse drug reaction, safety assessment, including physical examination and vital signs, will be done and additional blood samples will be collected within 1 hour of the hypersensitivity reaction (eg, tryptase, C3, C3a, C4, C5, and C5a, as well as possible additional exploratory testing) and one sample for IgE (and possible additional exploratory testing) between 8-24 hours after the reaction, if possible. In-patient observation can be extended and additional blood samples can be collected if deemed necessary at the discretion of the Investigator and Medical Monitor.</u></p> | 3, 12     |
| 12.7/Post-Infusion Follow-Up (Years 2-5)       | <p><u>During Years 2-5, at applicable sites, certain study assessments may be performed by a mobile nursing (MN) professional at the patient's home or another suitable location, such as their school or office, to improve access and convenience for patients participating in the study. The Sponsor may select a healthcare company that will be responsible for providing MN services for participating sites (the MN vendor). The MN vendor is responsible for ensuring that all MN professionals are licensed, qualified, and in good standing, as per applicable regulations, and that appropriate background checks have been performed. If the investigator at a participating site determines that MN services are appropriate for a patient and the patient gives written informed consent to participate in MN visits, the MN network will communicate with</u></p>   | 6         |



| Section No./Title               | Revision   | Rationale  |
|---------------------------------|--|------------|
|                                 | <u>the patient and the patient's site. MN visits will be allowed for the Q4W (during Year 2) and Q6W (during Years 3-5) visits; the Q3M visits during Years 2-5 will not be performed by an MN professional but will be done at the study site.</u>  |            |
| 12.7.1/Year 2 Q4W               | <p>During Year 2, every 4 weeks (+ 2 weeks, or as scheduled to align with visits for performing assessments to be done every 3 months [Section 12.7.3]), the following procedures will be performed:</p> <ul style="list-style-type: none"> <li>• <u>Assessment of Adverse Events and Concomitant Medications (including review of subject diary for bleeding and FVIII use)</u></li> <li>• <u>PCR of vector DNA in blood, saliva, urine, semen, and stools (if required)</u> <ul style="list-style-type: none"> <li>○ <u>Sample testing during Year 2 is not required if at least 3 consecutive samples are negative during the Post-Infusion Follow-Up period in Weeks 1-52. Subjects who have not had 3 consecutive negative semen samples by Week 52 should continue to have PCR testing of semen every 4 weeks during Years 2 until 3 consecutive negative samples are documented (or upon consultation between the Investigator and Medical Monitor).</u></li> </ul> </li> </ul> | 10, 16     |
| 12.7.2/Years 3-5 Q6W            | <p>During Years 3-5, every 6 weeks (<math>\pm</math> 2 weeks), the following procedures will be performed:</p> <ul style="list-style-type: none"> <li>• <u>Assessment of Adverse Events and Concomitant Medications (including review of subject diary for bleeding and FVIII use)</u></li> <li>• <u>PCR of vector DNA in blood, saliva, urine, semen, and stools (if required)</u> <ul style="list-style-type: none"> <li>○ <u>Sample testing during Years 3-5 is not required if at least 3 consecutive samples are clear by the end of Year 2. Subjects who have not had 3 consecutive negative semen samples by the end of Year 2 should continue to have PCR testing of semen every 6 weeks during Years 3-5 until 3 consecutive negative samples are documented (or upon consultation between the Investigator and Medical Monitor).</u></li> </ul> </li> </ul>  | 10, 11, 16 |
| 12.7.3/Years 2-5 Every 3 Months | <p><u>Every 3 months (<math>\pm</math> 2 weeks), the following procedures will be performed:</u></p> <ul style="list-style-type: none"> <li>• <u>Liver Function Tests (refer to Table 9.7.8.3.1)</u> <ul style="list-style-type: none"> <li>○ <u>LFTs may be monitored more or less frequently (and in particular when ALT values are <math>&gt;1.5x</math> ULN) based on discussion between the Medical Monitor and the Investigator and review of subject data, but LFTs will be monitored at least twice weekly during periods when a subject's ALT is <math>\geq 3x</math> ULN.</u></li> </ul> </li> </ul>   | 16         |





| Section No./Title  | Revision  | Rationale |
|--|---|-----------|
|  | <ul style="list-style-type: none"> <li>• <u>FVIII Assays</u> <ul style="list-style-type: none"> <li>○ <u>FVIII activity level (chromogenic FVIII assay)</u></li> <li>○ <u>FVIII activity level (one-stage clot FVIII assay)</u></li> <li>○ <u>FVIII coagulation activity exploratory assay</u></li> <li>○ <u>Bethesda assay (with Nijmegen modification) for FVIII inhibitor level</u> <ul style="list-style-type: none"> <li>▪ <u>If a subject tests positive in the Bethesda assay (with Nijmegen modification) during Years 3-5, a fresh sample should be collected within 4 weeks of the initial visit that had a positive result.</u></li> </ul> </li> <li>○ <u>FVIII protein assay</u></li> </ul> </li> </ul>   |           |
| <p><del>12.7.4/Years 2-5 Every 4 Weeks (As Needed)</del></p> | <p><del>The following assessment should be performed every 4 weeks during Years 2-5, as needed:</del></p> <ul style="list-style-type: none"> <li>• <del>PCR of vector DNA in blood, saliva, urine, semen, and stools</del></li> </ul> <p><del>Sample testing during Years 2-5 is not required if at least 3 consecutive samples are clear during the Post-Infusion Follow-Up period in Weeks 1-52. Subjects who have not had 3 consecutive negative semen samples by Week 52 should continue to have PCR testing of semen every 4 weeks until 3 consecutive negative samples are documented (or upon consultation between the Investigator and Medical Monitor).</del></p>  | 16        |
| 14.1.1/Interim Analyses                                      | <p>The primary efficacy endpoint for the interim analysis is change in the hFVIII activity, as measured by one-stage clotting assay, during Weeks 23-26 post-BMN 270 infusion from baseline. Each subject's hFVIII activity during Weeks 23-26 is defined as the median of the values obtained during this 4-week window. Values for hFVIII activity will be excluded if obtained within 72 hours since the last infusion of exogenous FVIII protein concentrates. A 2-sided one-sample t-test will be used to test the null hypothesis that the change is 0 or less against the alternative hypothesis that the change is greater than 0. In addition, subjects' hFVIII activity post-Week 23, defined as the median of the values obtained from Week 23 to the time of last follow-up, will be analyzed similarly as an important sensitivity analysis, utilizing additional data beyond Week 26. Descriptive summaries of the proportions of subjects whose FVIII activity during Weeks 23-26 and from Week 23 to the time of last follow-up is greater than or equal to select thresholds, such as 15, 25 and 30 IU/dL, and</p> | 2         |



| Section No./Title  | Revision  | Rationale |
|--|---|-----------|
|  | <p>the confidence intervals of the proportions will be provided, respectively. The FVIII activity as measured by chromogenic assay will be analyzed similarly, as a supportive analysis.</p> <p>The <del>Hochberg</del> <u>fallback</u> procedure (<a href="#">Wiens, 2005</a>) will be used to adjust for multiplicity of the interim analysis at Week 26 and the final analysis at Week 52 of the primary efficacy endpoint. (Regardless of the interim analysis results, the study <del>will be planned to continue upon the DMC's recommendation</del>, and the final analysis will be performed at Week 52.) At the final analysis at Week 52, the secondary efficacy endpoints will be tested hierarchically; the level of significance will be determined by the <del>truncated Hochberg</del> <u>procedure for parallel gatekeeping</u>. <del>These multiple comparison procedures are described in greater detail in Section -fallback procedure..</del></p> <p>The secondary and tertiary endpoints will be summarized descriptively at the interim (Week 26) analysis.</p> <p><u>The details of the interim analysis, including the control of Type I error rate, will be specified in an interim analysis plan.</u></p> |           |
| 14.1.2/Procedures for Accounting for Missing, Unused and Spurious Data | <p><del>Missing data imputation and sensitivity analyses will be conducted</del> to assess the impact of missing data on the primary <del>and secondary efficacy endpoint analysis</del> <u>endpoints analyses are described in the following sections</u>. Additional details regarding the handling of missing data will be provided in the SAP.</p>  | 2         |
| 14.2/Primary and Secondary Endpoints                                   | <p><u>For a subject with a missing value of the primary endpoint, the median value in the subject's last 4-week window containing a valid observation will be used. Additional analyses will be conducted to examine the sensitivity of the results to the handling of missing data, including analysis using observed cases, and a mixed model for repeated measures (MMRM) approach. Further detail will be provided in the SAP.</u></p> <p><u>The analyses for the primary endpoint will be performed using the efficacy analysis set as defined in Section 14.8.</u></p>  | 2         |
| 14.3/Secondary Efficacy Endpoints                                      | <p><u>The primary analyses for the secondary endpoints will be performed on the 110 subjects in the efficacy analysis set who will be followed up for approximately 6 months in the non-interventional study 270-902 prior to their enrollment in 270-301. The baseline values will be derived from the prospectively collected data in 270-902.</u></p> <p>For the first secondary efficacy endpoint at Week 52 (ie, the change in the annualized utilization (IU/kg) of exogenous FVIII replacement therapy during Weeks 5-52 post-BMN 270 infusion from baseline), a one-sample t-test will be</p>   | 2         |



| Section No./Title | Revision   | Rationale |
|-------------------|--|-----------|
|                   | <p>performed to test the null hypothesis that the change is 0 or greater against the alternative hypothesis that the change is less than 0. <u>The missing value of the change will be imputed as 0.</u></p> <p>For the second secondary efficacy endpoint at Week 52 (ie, the change in ABR, annualized bleeding rate, during Weeks 5-52 post-BMN 270 infusion from baseline), a one-sample t-test will be performed to test for non-inferiority of BMN 270 against FVIII prophylaxis (ie, the baseline ABR calculated using subjects' <del>historical medical records during the year prior to enrollment</del> data collected as part of 270-902) using a <u>non-inferiority</u> margin of 3.5, ie, to test the null hypothesis that the change is 3.5 or greater against the alternative hypothesis that the change is less than 3.5. If non-inferiority is demonstrated, the test for superiority of BMN 270 against FVIII prophylaxis will be performed. <del>The primary analysis of this endpoint is planned to be performed pooling all 70 enrolled subjects, assuming the baseline ABR of the first enrolled 20 subjects (whose baseline data is entirely based on historical medical records) and the baseline ABR of the later enrolled 50 subjects (whose baseline data is based on both data from historical medical records and data collected during study BMN 270-902) are similar. The poolability will be examined by comparing the corresponding baseline ABRs. Details will be provided in the statistical analysis plan.</del> <u>The missing value of the change will be imputed using the median value of the changes of all observed cases.</u></p> <p><u>A sensitivity analysis is planned to analyze ABR using a generalized linear mixed model assuming negative binomial as the underlying distribution. The model will include period (pre- to post-BMN 270 infusion) as the only factor. The actual number of bleeding episodes will be used as the independent variable with the time period adjustment (animalization) being implemented as the offset.</u></p> <p><u>To assess the impact of missing data, analyses using observed case are planned as sensitivity analyses for the secondary endpoints. Multiple imputation methods may also be performed.</u></p> <p>The primary and secondary efficacy hypotheses will be tested hierarchically according to the order described above. Multiple comparison procedures <u>are will be</u> described in greater detail in the <del>following</del> <u>SAP</u>.</p> <p><del>As described in Section 14.1.1, an interim analysis is planned after 20 treated subjects have completed the Week 26 visit (or have discontinued study participation prior to Week 26). As described in Section 14.1.1, an interim analysis is planned after 20 treated subjects have completed the Week 26 visit (or have discontinued study participation prior to Week 26).</del></p> |           |



| Section No./Title | Revision   | Rationale |
|-------------------|--|-----------|
|                   | <p>For controlling the probability of a Type I error for the interim and final analyses of the primary efficacy endpoint, the Hochberg procedure will be used. That is, if both the interim and final p values are <math>\leq 0.05</math>, then both are declared statistically significant; otherwise, if either p value is <math>\leq 0.025</math>, then that result is significant. (All p values are 2-sided.) Since the final analysis results are not available at the time of the interim analysis, the procedure will be implemented as follows.</p> <ul style="list-style-type: none"> <li>• If <math>p \leq 0.025</math> at the interim analysis, then the interim result is declared significant and the final analysis is carried out at the 0.05 level.</li> <li>• If <math>0.025 &lt; p \leq 0.05</math> at the interim analysis, then the final analysis is carried out at the 0.05 level. However, the significance of the interim result cannot be established at the time of the interim analysis; if <math>p \leq 0.05</math> for the final analysis, then both the interim and final analyses are declared significant, but if <math>p &gt; 0.05</math> for the final analysis, then neither the interim nor the final analysis is declared significant.</li> <li>• If <math>p &gt; 0.05</math> at the interim analysis, then the interim analysis is not declared significant, and the final analysis is carried out at the 0.025 level.</li> </ul> <p>Regardless of the interim analysis results, the study will continue to completion and the final analysis will be performed at Week 52.</p> <p>For controlling the probability of a Type I error for the primary and secondary efficacy endpoints at the final analysis, a hierarchical (sequential) multiple comparison procedure will be used, after applying the truncated Hochberg procedure for parallel gatekeeping. Specifically:</p> <ul style="list-style-type: none"> <li>• If both the interim and final results are significant (as described above), then at the final analysis the primary and secondary endpoints will be tested hierarchically using <math>\alpha = 0.05</math>.</li> <li>• If either the interim or the final result, but not both, is significant, then at the final analysis the primary and secondary endpoints will be tested hierarchically using <math>\alpha = 0.025</math>.</li> </ul> <p>If neither the interim nor the final result is significant, then at the final analysis the secondary endpoints will not be tested.</p> |           |



| Section No./Title                 | Revision   | Rationale |
|-----------------------------------|--|-----------|
| 14.7/Determination of Sample Size | <p><del>Seventy (70)</del> <u>One hundred and thirty (130)</u> subjects may be dosed in the study. The sample size for this study is based on clinical and statistical considerations in order to provide sufficient data to assess both safety and efficacy of BMN 270.</p> <p><u>For the primary endpoint, a sample size of 70130 will provide at least 95% power to demonstrate that the change in hFVIII activity during Weeks 49-52 from baseline is greater than 0, assuming an effect size of 0.6, using a one-sample t-test with a 2-sided significance level of 0.02505. The effect size of 0.6 is assumed based on Study 270-201 data. In Study 270-201 cohort 6E13, the mean (SD) of FVIII activity (IU/dL) at Week 52 (based on median values in a 4-week window around Week 52) were estimated as 103.8 (62.4), with a 95% confidence interval for the mean of (46.1 , 161.5). Using the lower limit of the confidence interval and assuming a baseline value of 1 (the largest value allowed per the study's inclusion/exclusion criteria), the effect size of change from baseline is approximately 0.7. For the sample size calculation, an effect size of 0.6 is assumed.</u></p> <p><del>A sample size of 70</del> <u>For the secondary endpoints, the analysis will be performed utilizing exogenous FVIII use and bleeding episode data from the 110 subjects whose baseline data will be prospectively collected for approximately 6 months in the non-interventional study 270-902, prior to their enrollment in Study 270-301. An analytic sample size of 110 will provide at least 95% power to demonstrate that the change in the annualized utilization (IU/kg) of exogenous FVIII replacement therapy during Week 5 to Week 52 post-BMN 270 infusion from the baseline is less than 0, assuming an effect size of 0.6 conservatively, using one-sample t-test with a 2-sided significance level of 0.02505.</u></p> <p><del>A sample size of 70</del> <u>For the analytic sample size calculation of the second secondary endpoint, ABR, it is assumed that the pre- and post-BMN 270 infusion population mean ABRs are 3.5 and 1 respectively, and the distribution of ABRs is negative binomial distribution with a dispersion parameter of 2.2. Given the underlying negative binomial distributions, the standard deviations of the pre- and post-BMN 270 infusion ABRs are calculated as 7.8 and 1.8 respectively. The mean (SD) of the change from the pre- to post-BMN 270 infusion ABRs are calculated as -2.5 (8) assuming the correlation between pre- and post-BMN 270 infusion ABRs is zero. Under this assumption, an analytic sample size of 110 will also have at least 95% power to demonstrate that the change in the annualized number of bleeding episodes requiring exogenous FVIII replacement treatment (ABR) during Week 5 to Week 52 of the study post-BMN 270 infusion from the baseline ABR is less than 3.5 (non-inferiority margin), assuming the pre- and post-BMN 270 infusion population mean ABRs are 3.5 and 1 respectively, using a one-sample t-test with a 2-sided significance level of 0.02505.</u></p> | 2         |



| Section No./Title  | Revision   | Rationale |
|--|--|-----------|
|  | <p>Under the same assumptions, a sample size of <del>70</del>110 will have approximately 90% power to demonstrate that the change is less than 0, <del>i.e.</del>, superiority of BMN 270 against FVIII prophylaxis.</p> <p>Overall, <del>a</del> <u>the planned</u> sample size <del>of 70</del> will have greater than 80% power for testing the primary and secondary efficacy endpoints hierarchically at the final analysis with a 2-sided significance level of <del>0.025</del>05.</p>  |           |
| <p><u>Appendix 1: Sampson's Anaphylaxis Criteria</u></p> | <p><u>According to the National Institute of Allergy and Infectious Disease/Food Allergy and Anaphylaxis Network (NIAID/FAAN) Second Symposium on the definition and management of anaphylaxis, anaphylaxis is highly likely when any one of the following 3 criteria are fulfilled:</u></p> <ol style="list-style-type: none"> <li>1. <u>Acute onset of an illness (minutes to several hours) with involvement of the skin, mucosal tissue, or both (eg, generalized hives, pruritus or flushing, swollen lips-tongue-uvula)</u><br/><br/><u>AND AT LEAST ONE OF THE FOLLOWING</u> <ol style="list-style-type: none"> <li>a. <u>Respiratory compromise (eg, dyspnea, wheeze-bronchospasm, stridor, reduced peak expiratory flow [PEF], hypoxemia)</u></li> <li>b. <u>Reduced blood pressure (BP) or associated symptoms of end-organ dysfunction (eg, hypotonia [collapse], syncope, incontinence)</u></li> </ol> </li> <li>2. <u>Two or more of the following that occur rapidly after exposure to a likely allergen for that patient (minutes to several hours):</u> <ol style="list-style-type: none"> <li>a. <u>Involvement of the skin-mucosal tissue (eg, generalized hives, itch-flush, swollen lips-tongue-uvula)</u></li> <li>b. <u>Respiratory compromise (eg, dyspnea, wheeze-bronchospasm, stridor, reduced PEF, hypoxemia)</u></li> <li>c. <u>Reduced BP or associated symptoms (eg, hypotonia [collapse], syncope, incontinence)</u></li> <li>d. <u>Persistent gastrointestinal symptoms (eg, crampy abdominal pain, vomiting)</u></li> </ol> </li> <li>3. <u>Reduced BP after exposure to known allergen for that patient (minutes to several hours):</u></li> </ol> | 3         |



| Section No./Title | Revision   | Rationale |
|-------------------|--|-----------|
|                   | <p>a. <u>Infants and children: low systolic blood pressure (age specific) or greater than 30% decrease in systolic BP</u></p> <p>b. <u>Adults: systolic BP of less than 90 mmHg or greater than 30% decrease from that person's baseline.</u></p> <p><u>Source: Sampson, 2006.</u></p> |           |

# BOMARIN®

## CLINICAL STUDY PROTOCOL

|   |   |
|---|---|
| <b>Study Title:</b>   | A Phase 3 Open-Label, Single-Arm Study To Evaluate The Efficacy and Safety of BMN 270, an Adeno-Associated Virus Vector-Mediated Gene Transfer of Human Factor VIII in Hemophilia A Patients with Residual FVIII Levels $\leq 1$ IU/dL Receiving Prophylactic FVIII Infusions |
| <b>Protocol Number:</b>   | 270-301   |
| <b>Active Investigational Product:</b>  | AAV5-hFVIII-SQ  |
| <b>IND/European Union Drug Regulating Authorities Clinical Trials (EudraCT) Number:</b> | 2017-003215-19<br>IND #: 017659   |
| <b>Indication:</b>  | Hemophilia A  |
| <b>Sponsor:</b>   | BioMarin Pharmaceutical Inc.<br>105 Digital Drive<br>Novato, CA 94949   |
| <b>Development Phase:</b>   | Phase 3   |
| <b>Sponsor's Responsible Medical Monitor:</b>   | PI [REDACTED], MD, MPhil<br>PI [REDACTED]<br>BioMarin Pharmaceutical Inc.<br>105 Digital Drive<br>Novato, CA 94949  |
| <b>Duration of Subject Participation:</b>   | Approximately 264 weeks   |
| <b>Dose:</b>  | 6E13 vg/kg  |
| <b>Study Population:</b>  | Males aged 18 or older  |
| <b>Date of Original Protocol:</b>   | 14 August 2017  |
| <b>Date of Amendment 1 (United States Specific):</b>                                    | 2 October 2017  |
| <b>Date of Amendment 1 (Global)</b>   | 25 January 2018   |
| <b>Date of Amendment 2 (Germany-Specific)</b>   | 26 June 2018  |
| <b>Date of Amendment 2 (Global)</b>   | 28 June 2018  |
| <b>Date of Amendment 3 (Global)</b>   | 24 August 2018  |

Property of BioMarin

**CONFIDENTIAL**

May not be divulged, published, or otherwise disclosed to others without prior written approval from BioMarin.

This study will be conducted according to the principles of Good Clinical Practice as described in the U.S. Code of Federal Regulations and the International Conference on Harmonisation Guidelines, including the archiving of essential documents





---

## CLINICAL STUDY PROTOCOL AMENDMENT SUMMARY

### Amendment 3

**Date: 24 August 2018**

---

#### RATIONALE AND SUMMARY OF CHANGES

A summary of major changes covered by Amendment 3 to the 270-301 protocol is provided below:

1. HIV-positive patients are now excluded from the study.

**Rationale:** An HIV-positive subject in Study 270-302 developed markedly elevated transaminase levels after receiving 4E13 vg/kg of BMN 270. The subject was receiving HAART treatment for his HIV infection, and it is hypothesized that the combination of BMN 270, one or more of his HAART medications, and/or unsuspected underlying hepatic disease may have contributed to the subject's elevated transaminase levels. Out of an abundance of caution for the long-term liver health of HIV-positive patients who are receiving HAART and may be interested in receiving gene therapy, further enrollment of HIV-positive subjects will be suspended in 270-301. Of note, this change supersedes the one made in Amendment 2 of the 270-301 protocol.

2. Efavirenz and lamivudine have been added to the list of prohibited concomitant medications.

**Rationale:** The subject in 270-302 referenced above was receiving efavirenz and lamivudine as part of his HAART regimen, and these are considered the most potentially likely medications to have contributed to his elevated transaminase levels.

3. The exclusion criterion concerning liver test levels at Screening have been changed to require all assessed liver tests (ie, alanine aminotransferase, aspartate aminotransferase, alkaline phosphatase, gamma-glutamyltransferase, and total bilirubin) to be no higher than the 1.25 times the upper limit of normal for eligibility purposes.

**Rationale:** A subject with Gilbert's syndrome in Study 270-301 developed elevated transaminase levels after receiving 6E13 vg/kg of BMN 270. Although other subjects with Gilbert's syndrome or HIV infection have been safely treated in small numbers in BMN 270 clinical trials to-date, the purpose of this amendment is to focus development excluding groups of patients hypothesized to have potential risk factors for interactions with BMN 270. Restricting the range of acceptable baseline liver test levels will help ensure that entering



subjects have the best chance to tolerate BMN 270 without experiencing potential hepatocellular injury subsequently.

4. An additional fasting serum sample will be drawn on Day 1, in case it is needed for future exploratory assessments.

**Rationale:** The additional sample will enable the conduct of exploratory assessments prior to BMN 270 infusion.

5. The timing of assessment visits during Years 2-5 has been modified.

**Rationale:** The original timing (which required visits on every 4 week, every 6 week, and every 3 month schedules) created burdens on sites in trying to align visits within allowed visit windows to minimize subject burden. The revised timing (which has substituted visits every 12 weeks and at specified end of year timepoints for the every 3 month visits) has simplified the calendar of visits and should ease site burden. Of note, this change supersedes the one made in Amendment 2 of the 270-301 protocol.

6. An abbreviated visit schedule has been made available during Years 2-5 for subjects who are considered to have not responded to BMN 270 therapy.

**Rationale:** Treatment failure—manifesting as either failure to achieve FVIII activity  $\geq 5$  IU/dL by Week 52 or inability to maintain independence from prophylactic FVIII replacement therapy due to joint bleeding episodes, in the judgment of the Investigator—may, at the Investigator’s discretion and after discussion with the Medical Monitor, enable subjects to follow an abbreviated visit schedule after Week 52 of the study by attending only the Q12W and End of Year visits during Years 2-5.

Subjects who meet the “treatment failure” definition and wish to follow an abbreviated schedule but who have not cleared vector shedding from all fluids must still provide samples for assessment every 4 weeks (during Year 2) or every 6 weeks (during Years 3-5) until vector shedding has cleared. Subjects may provide samples on the designated study visit dates either at the sites or through use of a mobile nursing (MN) professional.

7. Additional details have been included concerning information to be collected as part of the medical history assessment at Screening.

**Rationale:** In subjects with a history of hepatitis B or hepatitis C infection, information on the specific treatments received for that infection should be collected. In addition, any previous pharmacokinetic data collected at the time the subject was receiving on-demand or prophylactic FVIII treatment should be collected. This additional history data could help explain a subject’s FVIII response (or lack of FVIII response) to BMN 270.



8. The statistical analysis population definitions and language surrounding the primary endpoint have been updated.

**Rationale:** Changes have been made to the statistical section of the protocol based on recently issued draft guidance from the United States Food and Drug Administration (FDA) for human gene therapy for hemophilia, with additional details to be provided in the statistical analysis plan.

9. Language concerning when to consider restarting FVIII prophylaxis following BMN 270 infusion has been modified.

**Rationale:** The decision for reinstatement of FVIII prophylaxis should be based on clinical grounds (eg, the advent of bleeding episodes), in consultation with the Medical Monitor. The need to reinstate FVIII prophylaxis if the FVIII activity is below a certain level post-BMN 270 has not yet been clinically established but will be informed by results from this study.

10. An additional criterion to initiate therapeutic oral corticosteroids for elevated alanine aminotransferase (ALT) levels, following consultation with the Medical Monitor, of ALT > ULN and > 2x baseline value has been added.

**Rationale:** The addition will provide flexibility to initiate therapeutic oral corticosteroids, following consultation with the Medical Monitor, in a timely manner with respect to elevations in ALT levels.

11. Changes have been made to correct minor errors and for purposes of clarity and consistency.

Refer to Section [25](#) for a summary of revisions to Amendment 2 (dated 28 June 2018).

#### **Amendment 2 Changes (dated 28 June 2018)**

In addition to the changes made as part of Amendment 3 (and detailed above), the following changes were previously made as part of Amendment 2 to the 270-301 protocol:

1. The sample size of the study was changed to 130, and the number of potential sites was increased to 60.

**Rationale:** The sample size was increased due to changes in the assumptions for sample size calculation. The calculation of baseline value for the primary analysis of annualized bleeding rate (ABR) changed from using one-year data before screening on all subjects to using approximately 6-month data collected from subjects enrolled in Study 270-902. This change resulted in an increase in the variance used for sample size collection and, hence, an increased sample size.

2. Details of the sample size calculation, missing data handling, and sensitivity analyses were added.

**Rationale:** These details were added for purposes of clarifying the planned statistical analyses to be performed for this study.

3. Language concerning the occurrence and management of infusion-related reactions was added.

**Rationale:** Three subjects recently experienced medically important infusion-related reactions (all grade 2) associated with valoctocogene roxaparvovec administration that were reported as serious adverse events due to prolonged observation in the hospital. Two subjects were enrolled in 270-301, and one subject was enrolled in Study 270-203 (phase 1/2, open-label study in subjects with pre-existing AAV5 antibodies receiving the 6E13 vg/kg dose of BMN 270). All of these infusion-related reactions were effectively managed clinically and resolved without any clinical sequelae.

The initial infusion rate will be 1 mL/min, which should be increased every 30 minutes by 1 ml/min to a maximum of 4 mL/min, provided that the subject is asymptomatic and tolerates the infusion. Adjustment/interruption of the infusion rate and/or duration may be required in the event of an adverse reaction occurring during the infusion. If necessary, anti-histamine, anti-pyretic, and/or corticosteroid administration is permitted prior to restarting an infusion interrupted by an infusion-related reaction.

To better elucidate the mechanisms of infusion-related hypersensitivity reactions, additional plasma samples will be taken within 1 hour of onset of a suspected infusion-related reaction and again 8 to 24 hours following resolution of symptoms. Samples will be used to assess acute phase response reactants, complement activation, inflammatory biomarkers, and IgE.

4. Language in the inclusion criterion related to a subject's history of FVIII inhibitors was clarified.

**Rationale:** The original language caused some issues of misinterpretation of Sponsor intent. The revised language removes the ambiguity.

5. Language regarding the HIV inclusion criterion was modified.

**Rationale:** The original language was reported as being unclear and leading to misunderstanding of sponsor intent. The revised language clarifies the inclusion criterion.



6. Language was added to permit use of mobile nursing (MN) services, provided the site is able to implement them and the subject consents, for non-every 3-month visits after Week 52.

**Rationale:** Allowing for mobile nursing services at the every 4 week (during Year 2) and every 6 week (during Years 3-5) visits will help alleviate subject travel burden.

7. Language was added to include ABO testing.

**Rationale:** ABO blood group results will be collected at Baseline to potentially correlate with FVIII activity level results in an exploratory manner.

8. Clarified that, on the day of infusion, subjects are not required to be admitted to a hospital to receive the infusion (ie, the infusion may be conducted in any facility that has the requisite capabilities to prepare and perform the infusion, as well as monitor subjects for at least 8 hours).

**Rationale:** Inpatient admission is not required for the infusion and 8-hour post-infusion observation period.

9. Clarified that the requirement for contraception use can end as early as Week 12, in the case that a subject has had 3 consecutive negative semen vector shedding assessments prior to that time point.

**Rationale:** Language in the protocol that stated that all subjects must continue with contraception for at least 26 weeks after infusion was inconsistent with the statement that semen sampling could be stopped as early as Week 12 if a subject had had 3 consecutive negative assessments. Revised language makes it clear that all subjects must remain on contraception and provide semen samples for assessment through Week 12, but after that timepoint, both contraception and semen sample assessment can be discontinued once 3 consecutive negative results have been obtained.

10. Clarified that assessment of concomitant medications and adverse events should be performed at the every 4-week visits during Year 2, and at the every 6-week visits during Years 3-5.

**Rationale:** Previously, the protocol called for assessment of AEs and concomitant medications every 3 months during Years 2-5; however, assessment at each visit during Years 2-5 is more appropriate and does not significantly increase subject or site burden.

11. Clarified that vector shedding assessments, if required, can be performed at the every 6-week visits during Years 3-5.

**Rationale:** Previously, the protocol called for vector shedding assessments, if required, to be done every 4 weeks after Week 52 until clearance. During Years 3-5, when subjects are being assessed for FVIII and liver function every 6 weeks, an every 4-week schedule for



---

vector shedding would add to subject burden. Obtaining results every 6 weeks is sufficient to monitor vector shedding for subject safety and also aligns these assessments with the FVIII and liver function assessment visits.

12. Added language that subjects will fast for at least 8 hours prior to collection of pre-infusion laboratory samples on the day of infusion.

**Rationale:** A fasting lipid panel is part of the infusion day laboratory assessment; as such, subjects need to fast for an adequate amount of time prior to the assessment to allow for accurate results.

13. Clarified that hepatitis B testing at Screening should include hepatitis B surface antigen (HBsAg), hepatitis B surface antibody (HBsAb), and hepatitis B core antibody (HBcAb) testing.

14. Added language clarifying that if the investigational product preparation, infusion, and post-infusion observation period require transfer to an inpatient setting for completion, in the absence of an adverse event (AE), this will not be considered a serious AE for safety reporting purposes.

15. The vector genome schematic figure was updated.

16. Changes were made to correct minor errors and for purposes of clarity and consistency.



## 2 SYNOPSIS

|   |   |  |
|---|---|--|
| <p><b>NAME OF COMPANY</b><br/>BioMarin Pharmaceutical Inc.<br/>105 Digital Drive<br/>Novato, CA 94949</p> <p><b>NAME OF FINISHED PRODUCT:</b><br/>BMN 270</p> <p><b>NAME OF ACTIVE INGREDIENT:</b><br/>AAV5-hFVIII-SQ</p>   | <p><b>SUMMARY TABLE</b><br/>Referring to Part of the<br/>Dossier:</p> <p>Volume:</p> <p>Page:</p> <p>Reference:</p> | <p><b>FOR NATIONAL<br/>AUTHORITY USE<br/>ONLY:</b></p> |
| <p><b>TITLE OF STUDY:</b><br/>A Phase 3 Open-Label, Single-Arm Study To Evaluate The Efficacy and Safety of BMN 270, an Adeno-Associated Virus Vector-Mediated Gene Transfer of Human Factor VIII in Hemophilia A Patients with Residual FVIII Levels <math>\leq</math> 1 IU/dL Receiving Prophylactic FVIII Infusions</p>  |   |  |
| <p><b>PROTOCOL NUMBER:</b><br/>270-301</p>  |   |  |
| <p><b>STUDY SITES:</b><br/>Approximately 60 sites worldwide.</p>  |   |  |
| <p><b>PHASE OF DEVELOPMENT:</b><br/>Phase 3</p>   |   |  |
| <p><b>STUDY RATIONALE:</b><br/>Hemophilia A (HA) is an X-linked recessive bleeding disorder that affects approximately 1 in 5,000 males. It is caused by deficiency in the activity of coagulation factor VIII (FVIII), an essential cofactor in the intrinsic coagulation pathway. This disorder can be either inherited, due to a genetic aberrancy, or an acquired immunologic process, leading to insufficient quantities of FVIII or a dysfunctional FVIII, but all are characterized by a defective coagulation process. The clinical phenotype of HA patients generally correlates tightly with the level of residual expression. Severe HA is classified as FVIII activity less than 1% of wild-type (<math>&lt;</math> 1 IU/dL), moderate disease comprises 1-5% of wild-type activity and the mild form is 5-40% activity. The clinical manifestations of severe HA are frequent spontaneous bleeding episodes, predominantly in joints and soft tissues, with a substantially increased risk of death from hemorrhage when the brain is involved. Subjects with moderate disease can exhibit manifestations similar to those seen in patients with severe HA, resulting in a comparable bleeding phenotype.</p> <p>Treatment of severe HA presently consists of intravenous injection of plasma-derived or recombinant human FVIII protein (rhFVIII) concentrates, both as prophylaxis 2-3 times per week, and at the time of a bleed, to prevent or control bleeding episodes, respectively. The half-life for FVIII (12 to 18 hours for most approved products) necessitates frequent infusions, and although a major advance in the treatment of HA, it remains common for severe HA patients to continue to have multiple bleeding events on prophylactic therapy (median ABR of 1-4 with prophylaxis treatment in a recently published retrospective observational study (Berntorp, 2017) and between 1-2 in 6 prospective FVIII interventional studies) and on-demand-only therapy (median ABR of 4.5-18 in a recently published retrospective study (Berntorp, 2017) and between 20-60 in</p> |   |  |





| <b>NAME OF COMPANY</b><br>BioMarin Pharmaceutical Inc.<br>105 Digital Drive<br>Novato, CA 94949<br><br><b>NAME OF FINISHED PRODUCT:</b><br>BMN 270<br><br><b>NAME OF ACTIVE INGREDIENT:</b><br>AAV5-hFVIII-SQ   | <b>SUMMARY TABLE</b><br>Referring to Part of the<br>Dossier:<br><br>Volume:<br><br>Page:<br><br>Reference: | <b>FOR NATIONAL<br/>           AUTHORITY USE<br/>           ONLY:</b> |
|---|--|---|
| <p>6 prospective FVIII interventional studies). The consequence of multiple bleeding events is the development of debilitating multiple-joint arthropathy and substantially increased risk of death. Chemical modification (eg, direct conjugation of polyethylene glycol (PEG) polymers) and bioengineering of FVIII (eg, FVIII-Fc fusion proteins) improve half-life by approximately 50%, and thus, show promise in reduced dosing and maintaining activity levels above a 1% trough for a greater proportion of the dosing interval. However, patients with severe HA who are treated with extended half-life FVIII remain dependent on multiple infusions to maintain critical levels of FVIII activity. There is therefore a strong unmet need for a fully preventive treatment of HA to give patients a FVIII level compatible with a normal and hemorrhage-free life.</p> <p>Gene therapy offers the potential of disease-modifying therapy by continuous endogenous production of active FVIII following a single intravenous infusion of a vector encoding the appropriate gene sequence for long-term episomal expression. Hemophilia A is well-suited for a gene replacement approach because clinical manifestations are attributable to the lack of a single gene product (FVIII) that circulates in minute amounts (200 ng/ml) in the plasma. Tightly regulated control of gene expression is not essential, and even modest increases in the level of FVIII (any increase of the plasma level by 2 ng/ml induces an increase in activity of 1%) can ameliorate the severe form of hemophilia A. Thus, relatively small changes in endogenous FVIII activity can result in clinically relevant improvements in disease phenotype. Finally, the circulating FVIII response to gene transduction can be assessed using validated quantitative rather than qualitative endpoints that are easily assayed using established laboratory techniques.</p> <p>Several different gene transfer strategies for FVIII replacement have been evaluated, but adeno-associated viral (AAV) vectors show the greatest promise. They have an excellent and well-defined safety profile, and can direct long-term transgene expression with tropism and promoter specificity for specific tissues, such as the liver (for serotypes 2, 5 and 8 among others). Indeed, an ongoing gene therapy clinical trial for a related disorder, hemophilia B, has established that stable (median follow-up of 3.2 years) expression of human factor IX (hFIX) at levels that are sufficient for conversion of their bleeding phenotype from severe to moderate or mild is achievable following a single peripheral vein infusion of AAV8-hFIX vector. Several participants in this trial have been able to discontinue factor prophylaxis without suffering spontaneous hemorrhages, even when they undertook activities that previously resulted in bleeding. Thus, gene therapy treatment has resulted in a substantial improvement in their quality of life (Nathwani, 2014).</p> <p>BMN 270 is an AAV5-based gene therapy vector that expresses the SQ form of hFVIII under the control of a hybrid human liver-specific promoter (Figure 1).</p> |  |   |



|   |  |   |
|---|--|---|
| <b>NAME OF COMPANY</b><br>BioMarin Pharmaceutical Inc.<br>105 Digital Drive<br>Novato, CA 94949<br><br><b>NAME OF FINISHED PRODUCT:</b><br>BMN 270<br><br><b>NAME OF ACTIVE INGREDIENT:</b><br>AAV5-hFVIII-SQ | <b>SUMMARY TABLE</b><br>Referring to Part of the<br>Dossier:<br><br>Volume:<br><br>Page:<br><br>Reference: | <b>FOR NATIONAL<br/>         AUTHORITY USE<br/>         ONLY:</b> |
|---|--|---|

**Figure 1. hFVIII-SQ Vector Genome Schematic**

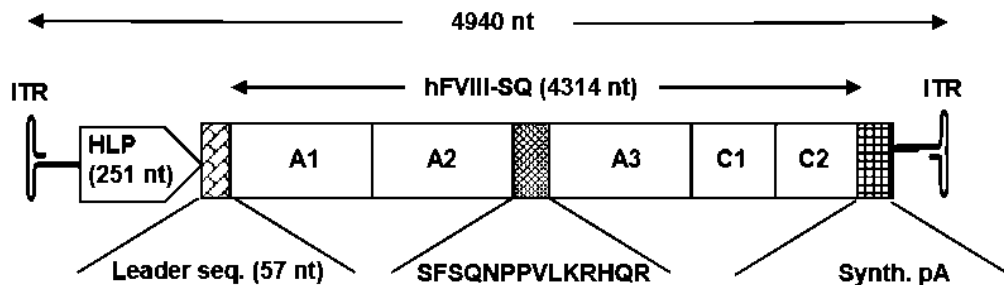

Legend –Note that schematic is not to scale; nt = nucleotides

BMN 270 will be delivered by a single intravenous dose and is designed to achieve stable, potentially life-long expression of active hFVIII in the plasma, synthesized from vector-transduced liver tissue.

BMN 270 is being evaluated in clinical study 270-201, an ongoing first-in-human, phase 1/2 dose escalation study in subjects with severe HA designed to assess the safety and efficacy of BMN 270 at various dose levels (6E12 vg/kg, 2E13 vg/kg, 4E13 vg/kg, 6E13 vg/kg). Specifically, 270-201 explores the relationship of vector dose to the augmentation of residual FVIII activity and whether these levels are sufficient to alter the clinical phenotype. Preliminary results from 270-201 have demonstrated that following gene transfer, FVIII activity above 15% (15 IU/dL) and, in many cases, within the normal range for FVIII, is achievable with a dose of 4-6E13 vg/kg with an acceptable safety profile (Pasi, 2017).

The current study is a Phase 3, single-arm, open-label study designed to assess whether, in an expanded sample, BMN 270 can safely alter the clinical phenotype of hemophilia A patients with residual FVIII activity  $\leq 1$  IU/dL.

**OBJECTIVES:**

The primary efficacy objective of the study is to:

- Assess the efficacy of BMN 270 defined as FVIII activity, as measured by chromogenic substrate assay, during Weeks 49-52 following intravenous infusion of BMN 270

The secondary efficacy objectives of the study are to:

- Assess the impact of BMN 270 on usage of exogenous FVIII replacement therapy from Week 5 to Week 52



| <b>NAME OF COMPANY</b><br>BioMarin Pharmaceutical Inc.<br>105 Digital Drive<br>Novato, CA 94949<br><br><b>NAME OF FINISHED PRODUCT:</b><br>BMN 270<br><br><b>NAME OF ACTIVE INGREDIENT:</b><br>AAV5-hFVIII-SQ   | <b>SUMMARY TABLE</b><br>Referring to Part of the<br>Dossier:<br><br>Volume:<br><br>Page:<br><br>Reference: | <b>FOR NATIONAL<br/>           AUTHORITY USE<br/>           ONLY:</b> |
|---|--|---|
| <ul style="list-style-type: none"> <li>Assess the impact of BMN 270 on the number of bleeding episodes requiring exogenous FVIII replacement therapy from Week 5 to Week 52</li> </ul> <p>The tertiary efficacy objective of the study is to:</p> <ul style="list-style-type: none"> <li>Assess the impact of BMN 270 on patient-reported outcomes (PROs) at Week 52 of the study compared to baseline</li> </ul> <p>The safety objectives of the study are to:</p> <ul style="list-style-type: none"> <li>Evaluate the safety of BMN 270 during the first 52 weeks following intravenous infusion</li> <li>Assess the long-term safety of BMN 270</li> </ul>   |  |   |
| <p><b>STUDY DESIGN AND PLAN:</b></p> <p>This is a Phase 3, single-arm, open-label study in hemophilia A patients with residual FVIII levels <math>\leq 1</math> IU/dL treated continuously with prophylactic exogenous FVIII for a minimum of one year prior to enrollment. Subjects will be enrolled at approximately 60 sites worldwide. Subjects must have high-quality, well-documented historical data available concerning previous bleeding episodes and exogenous FVIII usage over the previous 12 months in order to be eligible to enroll in the study.</p> <p>Approximately 130 adult subjects with severe HA will receive a 6E13 vg/kg dose of BMN 270 as a single intravenous infusion. Approximately 20 subjects will enroll in the study with at least 12 months of well-documented high-quality historical data concerning previous bleeding episodes and exogenous FVIII usage, while approximately 110 subjects will enroll in the study after having completed approximately 6 months' participation in the BioMarin-sponsored non-interventional study 270-902, in which bleeding and FVIII use data prior to gene therapy will be prospectively collected.</p> |  |   |

270-301 Amendment 3

Page 12

|   |   |   |
|---|---|---|
| <b>NAME OF COMPANY</b><br>BioMarin Pharmaceutical Inc.<br>105 Digital Drive<br>Novato, CA 94949<br><br><b>NAME OF FINISHED PRODUCT:</b><br>BMN 270<br><br><b>NAME OF ACTIVE INGREDIENT:</b><br>AAV5-hFVIII-SQ | <b>SUMMARY TABLE</b><br>Referring to Part of the Dossier:<br><br>Volume:<br><br>Page:<br><br>Reference: | <b>FOR NATIONAL AUTHORITY USE ONLY:</b> |
|---|---|---|

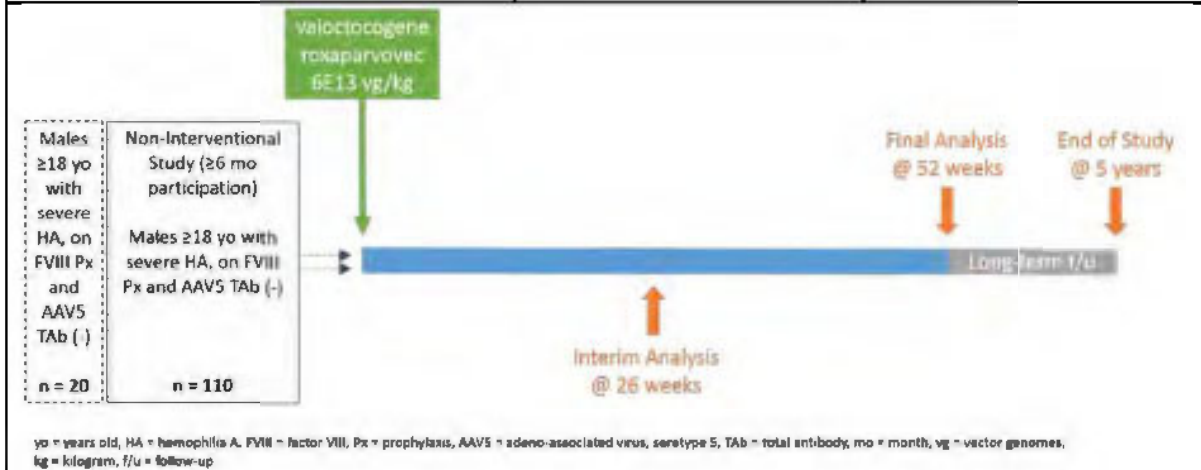

In order to minimize bias in the ongoing study and to assure safe and ethical conduct of the clinical trial, an independent Data Monitoring Committee (DMC), consisting of experts in clinical trials, statistics, and hemophilia, has been convened. The DMC will have sole access during the trial to amalgamated FVIII activity levels, FVIII usage, and bleeding data and review available safety and efficacy (eg, FVIII activity) data during the study on an ongoing basis; they may determine, based on emerging data and the risk/benefit profile, that further enrollment at 6E13 vg/kg should be discontinued in favor of a different dose of BMN 270, not to exceed 6E13 vg/kg. If the DMC recommends a dosing modification, then additional subjects may be enrolled, up to a total of approximately 130 subjects, at the new BMN 270 dose level (regardless of the number of subjects previously enrolled at 6E13 vg/kg).

An interim analysis is planned after 20 evaluable HIV-negative subjects have completed the Week 26 visit. Data will be reviewed by the DMC, based on the statistical analysis plan, and a formal recommendation will be made whether to continue the study as designed.

The final analysis for the study will be performed after all subjects have been followed for 52 weeks post-BMN 270 infusion. After the final analysis, safety and efficacy will then continue to be assessed long-term in all subjects for a total of approximately 5 years.

To avoid breakthrough bleeding, subjects will only discontinue exogenous prophylactic FVIII replacement therapy 4 weeks following infusion of BMN 270. Four weeks represents the time by which endogenous production of FVIII following gene transfer is expected to be efficacious, based on earlier results.



|  |   |  |
|--|---|--|
| <p><b>NAME OF COMPANY</b><br/>BioMarin Pharmaceutical Inc.<br/>105 Digital Drive<br/>Novato, CA 94949</p> <p><b>NAME OF FINISHED PRODUCT:</b><br/>BMN 270</p> <p><b>NAME OF ACTIVE INGREDIENT:</b><br/>AAV5-hFVIII-SQ</p>  | <p><b>SUMMARY TABLE</b><br/>Referring to Part of the<br/>Dossier:</p> <p>Volume:</p> <p>Page:</p> <p>Reference:</p> | <p><b>FOR NATIONAL<br/>AUTHORITY USE<br/>ONLY:</b></p> |
| <p>In subjects who experience recurring bleeding episodes, the Investigator and Medical Monitor will discuss whether to resume prior FVIII prophylaxis.</p> <p>Subjects who do not respond to BMN 270 treatment (ie, treatment failure, manifesting as either failure to achieve FVIII activity <math>\geq 5</math> IU/dL by Week 52 or inability to maintain independence from prophylactic FVIII replacement therapy due to joint bleeding episodes, in the judgment of the Investigator) may, at the Investigator's discretion and after discussion with the Medical Monitor, follow an abbreviated visit schedule after Week 52 of the study by attending only the Q12W and End of Year visits during Years 2-5.</p> <p>There will be an ongoing review of individual subject safety by the Medical Monitor, and both safety and efficacy data by the DMC. Therapeutic oral corticosteroids may be initiated when a subject's ALT values are elevated, and subsequent dosage adjustments made, after consultation between the Investigator and the Medical Monitor.</p> <p>Any safety signal may trigger a review of the data and possible additional immunogenicity studies or other diagnostics deemed necessary that include an assessment of cellular immune responses using collected peripheral blood mononuclear cells (PBMCs).</p>   |   |  |
| <p><b>NUMBER OF SUBJECTS PLANNED:</b><br/>Approximately 130 subjects may enroll into the study.</p>  |   |  |
| <p><b>DIAGNOSIS AND ALL CRITERIA FOR INCLUSION AND EXCLUSION:</b><br/>Patients are eligible to be included in the study only if all of the following criteria apply:</p> <ol style="list-style-type: none"> <li>1. Males <math>\geq 18</math> years of age with hemophilia A and residual FVIII levels <math>\leq 1</math> IU/dL as evidenced by medical history, at the time of signing the informed consent.</li> <li>2. Must have been on prophylactic FVIII replacement therapy for at least 12 months prior to study entry. High-quality, well-documented historical data concerning bleeding episodes and FVIII usage over the previous 12 months must be available.</li> <li>3. Treated/exposed to FVIII concentrates or cryoprecipitate for a minimum of 150 exposure days (EDs).</li> <li>4. Willing and able to provide written, signed informed consent after the nature of the study has been explained and prior to any study-related procedures.</li> <li>5. No previous documented history of a detectable FVIII inhibitor, and results from a Bethesda assay or Bethesda assay with Nijmegen modification of less than 0.6 Bethesda Units (BU) (or less than 1.0 BU for laboratories with a historical lower sensitivity cutoff for inhibitor detection of 1.0 BU) on 2 consecutive occasions at least one week apart within the past 12 months (at least one of which should be tested at the central laboratory).</li> </ol> |   |  |



| <b>NAME OF COMPANY</b><br>BioMarin Pharmaceutical Inc.<br>105 Digital Drive<br>Novato, CA 94949<br><br><b>NAME OF FINISHED PRODUCT:</b><br>BMN 270<br><br><b>NAME OF ACTIVE INGREDIENT:</b><br>AAV5-hFVIII-SQ  | <b>SUMMARY TABLE</b><br>Referring to Part of the<br>Dossier:<br><br>Volume:<br><br>Page:<br><br>Reference: | <b>FOR NATIONAL<br/>           AUTHORITY USE<br/>           ONLY:</b> |
|--|--|---|
| <p>6. Sexually active participants must agree to use an acceptable method of effective contraception, either double-barrier contraception (ie, condom + diaphragm; or condom or diaphragm + spermicidal gel or foam) or their female partner either using hormonal contraceptives or having an intrauterine device. Participants must agree to contraception use for at least 12 weeks post-infusion; after 12 weeks, subjects may stop contraception use only if they have had 3 consecutive semen samples with no detectable viral vector DNA.</p> <p>7. Willing to abstain from alcohol consumption for at least the first 52 weeks following BMN 270 infusion.</p> <p>Patients are excluded from the study if any of the following criteria apply:</p> <ol style="list-style-type: none"> <li>1. Detectable pre-existing antibodies to the AAV5 capsid.</li> <li>2. Any evidence of active infection or any immunosuppressive disorder, including HIV infection.</li> <li>3. Significant liver dysfunction with any of the following abnormal laboratory results:               <ul style="list-style-type: none"> <li>• ALT (alanine aminotransferase) &gt; 1.25x ULN;</li> <li>• AST (aspartate aminotransferase) &gt; 1.25x ULN;</li> <li>• GGT (gamma-glutamyltransferase) &gt; 1.25x ULN;</li> <li>• Total bilirubin &gt; 1.25x ULN;</li> <li>• Alkaline phosphatase &gt; 1.25x ULN; or</li> <li>• INR (international normalized ratio) ≥ 1.4.</li> </ul> </li> </ol> <p>Subjects whose liver laboratory assessments fall outside of these ranges may undergo repeat testing of the entire liver test panel within the same Screening window and, if eligibility criteria are met on retest, may be enrolled after confirmation by the Medical Monitor.</p> <ol style="list-style-type: none"> <li>4. Prior liver biopsy showing significant fibrosis of 3 or 4 as rated on a scale of 0-4 on the Batts-Ludwig (<a href="#">Batts, 1995</a>) or METAVIR (<a href="#">Bedossa, 1996</a>) scoring systems, or an equivalent grade of fibrosis if an alternative scale is used.</li> <li>5. Evidence of any bleeding disorder not related to hemophilia A.</li> <li>6. Platelet count of &lt; 100 x 10<sup>9</sup>/L.</li> <li>7. Creatinine ≥ 1.5 mg/dL.</li> </ol> |  |   |



| <b>NAME OF COMPANY</b><br>BioMarin Pharmaceutical Inc.<br>105 Digital Drive<br>Novato, CA 94949<br><br><b>NAME OF FINISHED PRODUCT:</b><br>BMN 270<br><br><b>NAME OF ACTIVE INGREDIENT:</b><br>AAV5-hFVIII-SQ   | <b>SUMMARY TABLE</b><br>Referring to Part of the<br>Dossier:<br><br>Volume:<br><br>Page:<br><br>Reference: | <b>FOR NATIONAL<br/>           AUTHORITY USE<br/>           ONLY:</b> |
|---|--|---|
| <ol style="list-style-type: none"> <li>8. Liver cirrhosis of any etiology as assessed by liver ultrasound.</li> <li>9. Chronic or active hepatitis B as evidenced by positive serology testing (hepatitis B surface antigen [HBsAg], hepatitis B surface antibody [HBsAb], and hepatitis B core antibody [HBcAb]) and confirmatory HBV DNA testing. Refer to the Centers for Disease Control (CDC) table for the interpretation of serological test results in the Laboratory Manual.</li> <li>10. Active Hepatitis C as evidenced by detectable HCV RNA or currently on antiviral therapy.</li> <li>11. Active malignancy, except non-melanoma skin cancer.</li> <li>12. History of hepatic malignancy.</li> <li>13. History of arterial or venous thromboembolic events (eg, deep vein thrombosis, non-hemorrhagic stroke, pulmonary embolism, myocardial infarction, arterial embolus), with the exception of catheter-associated thrombosis for which anti-thrombotic treatment is not currently ongoing.</li> <li>14. Known inherited or acquired thrombophilia, including conditions associated with increased thromboembolic risk, such as atrial fibrillation.</li> <li>15. Treatment with any investigational product within 30 days or 5 half-lives of the investigational product prior to the screening period. For subjects who have received a prior investigational product, all ongoing adverse events (AEs) experienced while receiving that investigational product must have resolved prior to screening for this study.</li> <li>16. Any condition that, in the opinion of the Investigator or Sponsor would prevent the patient from fully complying with the requirements of the study (including possible corticosteroid treatment outlined in the protocol) and/or would impact or interfere with evaluation and interpretation of subject safety or efficacy result.</li> <li>17. Prior treatment with any vector or gene transfer agent.</li> <li>18. Major surgery planned in the 52-week period following the infusion with BMN 270.</li> <li>19. Use of systemic immunosuppressive agents, not including corticosteroids, or live vaccines within 30 days before the BMN 270 infusion.</li> <li>20. Concurrent enrollment in another clinical study, unless it is an observational (non-interventional) clinical study that does not interfere with the requirements of the current protocol or have the potential to impact the evaluation of efficacy and safety of BMN 270 and with prior consultation with the Medical Monitor.</li> </ol> |  |   |





|  |  |   |
|--|--|---|
| <b>NAME OF COMPANY</b><br>BioMarin Pharmaceutical Inc.<br>105 Digital Drive<br>Novato, CA 94949<br><br><b>NAME OF FINISHED PRODUCT:</b><br>BMN 270<br><br><b>NAME OF ACTIVE INGREDIENT:</b><br>AAV5-hFVIII-SQ  | <b>SUMMARY TABLE</b><br>Referring to Part of the<br>Dossier:<br><br>Volume:<br><br>Page:<br><br>Reference: | <b>FOR NATIONAL<br/>         AUTHORITY USE<br/>         ONLY:</b> |
| 21. Known allergy or hypersensitivity to BMN 270 investigational product formulation.<br>22. Unwilling to receive blood or blood products for treatment of an adverse event and/or a bleeding episode.   |  |   |
| <b>INVESTIGATIONAL PRODUCT(S), DOSE, ROUTE AND REGIMEN:</b><br>Each subject will receive a single intravenous infusion of BMN 270 at 6E13 vg/kg. The volume of infusion will depend on the subject's weight.   |  |   |
| <b>REFERENCE THERAPY(IES), DOSE, ROUTE AND REGIMEN:</b><br>No reference therapy will be evaluated in this study.   |  |   |
| <b>DURATION OF TREATMENT:</b><br>BMN 270 is given as a single dose by intravenous infusion.  |  |   |
| <b>CRITERIA FOR EVALUATION:</b><br><u>Efficacy:</u><br>Primary efficacy endpoint: <ul style="list-style-type: none"> <li>• Change of the hFVIII activity, as measured by chromogenic substrate assay, during Weeks 49-52 post-BMN 270 infusion from baseline. Each subject's hFVIII activity during Weeks 49-52 is defined as the median of the values obtained during this 4-week window. Values for hFVIII activity will be excluded if obtained within 72 hours since the last infusion of exogenous FVIII protein concentrates.</li> </ul> Secondary efficacy endpoints: <ul style="list-style-type: none"> <li>• Change in the annualized utilization (IU/kg) of exogenous FVIII replacement therapy during Week 5 to Week 52 post-BMN 270 infusion from the baseline utilization of exogenous FVIII replacement therapy.</li> <li>• Change in the annualized number of bleeding episodes requiring exogenous FVIII replacement treatment (annualized bleeding rate, ABR) during Week 5 to Week 52 of the study post-BMN 270 infusion from the baseline ABR.</li> </ul> Tertiary efficacy endpoints: <ul style="list-style-type: none"> <li>• Change from baseline in the total score of HAEMO-QoL-A at Week 52 of the study post-BMN 270 infusion.</li> <li>• Change from baseline in the EQ-5D-5L score at Week 52 of the study post-BMN 270 infusion.</li> <li>• Change from baseline in the Haemophilia Activities List (HAL) score at Week 52 of the study post-BMN 270 infusion.</li> </ul> |  |   |



| <b>NAME OF COMPANY</b><br>BioMarin Pharmaceutical Inc.<br>105 Digital Drive<br>Novato, CA 94949<br><br><b>NAME OF FINISHED PRODUCT:</b><br>BMN 270<br><br><b>NAME OF ACTIVE INGREDIENT:</b><br>AAV5-hFVIII-SQ   | <b>SUMMARY TABLE</b><br>Referring to Part of the<br>Dossier:<br><br>Volume:<br><br>Page:<br><br>Reference: | <b>FOR NATIONAL<br/>           AUTHORITY USE<br/>           ONLY:</b> |
|---|--|---|
| <ul style="list-style-type: none"> <li>• Change from baseline in the Work Productivity and Activity Impairment plus Classroom Impairment Questions: Hemophilia Specific (WPAI+CIQ:HS) score at Week 52 of the study post-BMN 270 infusion.</li> <li>• Change from baseline in Patient Reported Outcomes, Burdens, and Experiences (PROBE) score at Week 52 of the study post-BMN 270 infusion.</li> </ul> <p><u>Safety:</u></p> <p>The following safety outcome measurements will be assessed:</p> <ul style="list-style-type: none"> <li>• Incidence of adverse events (AEs) and serious AEs (SAEs)</li> <li>• Change in clinical laboratory tests (serum chemistry and hematology)</li> <li>• Change in vital signs</li> <li>• Change in physical examination</li> <li>• Vector shedding (blood, urine, semen, feces, saliva)</li> <li>• Liver tests (LTs, including ALT, AST, GGT, total bilirubin, and alkaline phosphatase)</li> <li>• Immune response to FVIII transgene product and AAV5 capsid proteins</li> </ul> <p>Each subject will have comprehensive surveillance monitoring of LTs (once per week for Weeks 1-36, and then once every 2 weeks from Weeks 37-52) during Year 1. LTs will be monitored every four weeks during Year 2 and then every 6 weeks during Years 3-5 post-dose in the safety extension; the frequency and duration of LT testing may be changed based on discussion between the Medical Monitor and the Investigator, review of subject data, and/or by independent DMC feedback.</p> <p>There will be a detailed assessment of cellular and humoral responses to AAV5 capsid and FVIII protein.</p> <p><u>Pharmacodynamics:</u></p> <p>The FVIII protein concentration and activity level as measured by a validated immunoassay and a validated FVIII activity assay, respectively, will be used for plasma profiles; FVIII protein and activity will be used to determine PD parameters.</p> |  |   |





| <b>NAME OF COMPANY</b><br>BioMarin Pharmaceutical Inc.<br>105 Digital Drive<br>Novato, CA 94949<br><br><b>NAME OF FINISHED PRODUCT:</b><br>BMN 270<br><br><b>NAME OF ACTIVE INGREDIENT:</b><br>AAV5-hFVIII-SQ   | <b>SUMMARY TABLE</b><br>Referring to Part of the<br>Dossier:<br><br>Volume:<br><br>Page:<br><br>Reference: | <b>FOR NATIONAL<br/>           AUTHORITY USE<br/>           ONLY:</b> |
|---|--|---|
| <p><b>STATISTICAL METHODS:</b></p> <p><u>Sample Size</u></p> <p>Approximately one hundred and thirty (130) subjects may be dosed in the study. The sample size for this study is based on clinical and statistical considerations in order to provide sufficient data to assess both safety and efficacy of BMN 270.</p> <p>For the primary endpoint, a sample size of 130 will provide at least 95% power to demonstrate that the change in hFVIII activity during Weeks 49-52 from baseline is greater than 0, assuming an effect size of 0.6, using a one-sample t-test with a 2-sided significance level of 0.05.</p> <p>For the secondary endpoints, the analyses will be performed utilizing exogenous FVIII use and bleeding episode data from the 110 subjects whose baseline data will be prospectively collected for approximately 6 months in the non-interventional study 270-902, prior to their enrollment in 270-301. An analytic sample size of 110 will provide at least 95% power to demonstrate that the change in the annualized utilization (IU/kg) of exogenous FVIII replacement therapy during Week 5 to Week 52 post-BMN 270 infusion from baseline is less than 0, assuming an effect size of 0.6, using a one-sample t-test with a 2-sided significance level of 0.05.</p> <p>An analytic sample size of 110 will also have at least 95% power to demonstrate that the change in the annualized number of bleeding episodes requiring exogenous FVIII replacement treatment (ABR) during Week 5 to Week 52 of the study post-BMN 270 infusion from the baseline ABR is less than 3.5 (non-inferiority margin), assuming the pre- and post-BMN 270 infusion population mean ABRs are 3.5 and 1 respectively, using a one-sample t-test with a 2-sided significance level of 0.05. Under the same assumptions, a sample size of 110 will have approximately 90% power to demonstrate that the change is less than 0, i.e. superiority of BMN 270 against FVIII prophylaxis.</p> <p>Overall, the planned sample size will have greater than 80% power for testing the primary and secondary efficacy endpoints hierarchically with a 2-sided significance level of 0.05.</p> <p><u>Analysis Population</u></p> <p>The intention-to-treat (ITT) population is defined as all subjects who receive BMN 270 infusion, and the modified intention-to-treat (mITT) population is defined as subjects who receive BMN 270 infusion and are HIV-negative. The mITT population will be used for the primary efficacy analysis, and the ITT population will be used for the supportive efficacy analysis. The ITT population will also be used for the safety analysis.</p> <p><u>Analysis</u></p> <p>For the primary efficacy endpoint at Week 52 (ie, the change in the hFVIII activity during Weeks 49-52 post-BMN 270 infusion from baseline, as measured by chromogenic substrate assay),</p> |  |   |



| <b>NAME OF COMPANY</b><br>BioMarin Pharmaceutical Inc.<br>105 Digital Drive<br>Novato, CA 94949<br><br><b>NAME OF FINISHED PRODUCT:</b><br>BMN 270<br><br><b>NAME OF ACTIVE INGREDIENT:</b><br>AAV5-hFVIII-SQ   | <b>SUMMARY TABLE</b><br>Referring to Part of the<br>Dossier:<br><br>Volume:<br><br>Page:<br><br>Reference: | <b>FOR NATIONAL<br/>           AUTHORITY USE<br/>           ONLY:</b> |
|---|--|---|
| <p>a one-sample t-test will be used to test the null hypothesis that the change is 0 or less against the alternative hypothesis that the change is greater than 0. Descriptive summaries of the proportions of subjects whose FVIII activity during Weeks 49-52 is greater than or equal to select thresholds, such as 15, 25 and 30 IU/dL, and the confidence intervals of the proportions will also be provided.</p> <p>For the secondary endpoints, the analyses will be performed on 110 subjects in the mITT population whose baseline data will be prospectively collected for approximately 6 months in the non-interventional study 270-902 prior to their enrollment in 270-301.</p> <p>For the first secondary efficacy endpoint at Week 52 (ie, the change in the annualized utilization (IU/kg) of exogenous FVIII replacement therapy during Weeks 5-52 post-BMN 270 infusion from baseline), a one-sample t-test will be performed to test the null hypothesis that the change is 0 or greater against the alternative hypothesis that the change is less than 0.</p> <p>For the second secondary efficacy endpoint at Week 52 (ie, the change in the annualized number of bleeding episodes requiring exogenous FVIII replacement treatment during Weeks 5-52 post-BMN 270 infusion from baseline), a one-sample t-test will be performed to test for non-inferiority of BMN 270 against FVIII prophylaxis (ie, the baseline ABR calculated using subjects' data collected in 270-902) using a margin of 3.5, ie, to test the null hypothesis that the change is 3.5 or greater against the alternative hypothesis that the change is less than 3.5. If non-inferiority is demonstrated, the test for superiority of BMN 270 against FVIII prophylaxis will be performed.</p> <p>The primary efficacy endpoint and secondary efficacy endpoints will be tested hierarchically according to the order described above.</p> <p>An interim analysis is planned after approximately 20 evaluable HIV-negative subjects have completed the Week 26 visit (or have discontinued study participation prior to Week 26). The primary efficacy endpoint for the interim analysis involves hFVIII activity, as measured by chromogenic substrate assay, achieved post-BMN 270 infusion, as detailed in the statistical analysis plan (SAP).</p> <p>Adjustment for multiplicity of the interim analysis at Week 26 and the final analysis at Week 52 will be described in the SAP (regardless of the interim analysis results, the study is planned to continue upon the DMC's recommendation, and the final analysis will be performed at Week 52). At the final analysis at Week 52, the secondary efficacy endpoints will be tested hierarchically.</p> <p>The secondary efficacy endpoints at the interim analysis (Week 26) will be summarized descriptively.</p> <p>The tertiary endpoints will be analyzed at the interim (Week 26) and final (Week 52) analyses, irrespective of the aforementioned hierarchical testing.</p> |  |   |



| <b>NAME OF COMPANY</b>  | <b>SUMMARY TABLE</b>                 | <b>FOR NATIONAL</b>  |
|---|--------------------------------------|--|
| BioMarin Pharmaceutical Inc.<br>105 Digital Drive<br>Novato, CA 94949 | Referring to Part of the<br>Dossier: | <b>AUTHORITY USE</b>   |
| NAME OF FINISHED PRODUCT:<br>BMN 270                                  | Volume:                              | <b>ONLY:</b>   |
| NAME OF ACTIVE INGREDIENT:<br>AAV5-hFVIII-SQ                          | Page:                                |  |
|   | Reference:                           | <p>Details of the interim analysis, including the control of Type I error rate, will be specified in the SAP.</p> <p>Analysis of safety endpoints will be primarily descriptive. The incidence of AEs will be summarized by system organ class, preferred term, relationship to study drug, seriousness, and severity. Clinical laboratory test values, vital signs, vector shedding and immune response parameters will be summarized descriptively by visit.</p> |



### 3 TABLE OF CONTENTS

|  |    |
|--|----|
| CLINICAL STUDY PROTOCOL AMENDMENT SUMMARY.....                         | 2  |
| 2 SYNOPSIS.....  | 8  |
| 3 TABLE OF CONTENTS.....   | 21 |
| 4 LIST OF ABBREVIATIONS AND DEFINITIONS OF TERMS.....                  | 26 |
| 5 ETHICS.....  | 29 |
| 5.1 Institutional Review Board or Independent Ethics Committee .....   | 29 |
| 5.2 Ethical Conduct of Study .....                                     | 29 |
| 5.3 Subject Information and Informed Consent.....                      | 30 |
| 6 INVESTIGATORS AND STUDY ADMINISTRATIVE STRUCTURE .....               | 31 |
| 7 INTRODUCTION .....   | 32 |
| 7.1 Nonclinical Studies .....  | 32 |
| 7.2 Previous Clinical Studies .....                                    | 33 |
| 7.3 Study Rationale .....  | 33 |
| 7.4 Summary of Overall Risks and Benefits.....                         | 36 |
| 8 STUDY OBJECTIVES.....  | 38 |
| 9 INVESTIGATIONAL PLAN.....  | 39 |
| 9.1 Overall Study Design and Plan .....                                | 39 |
| 9.2 Discussion of Study Design, Including Choice of Control Group..... | 57 |
| 9.3 Selection of Study Population.....                                 | 57 |
| 9.3.1 Inclusion Criteria.....  | 57 |
| 9.3.2 Exclusion Criteria.....  | 58 |
| 9.3.3 Removal of Subjects from Treatment or Assessment .....           | 60 |
| 9.3.4 Subject Identification and Replacement of Subjects.....          | 62 |
| 9.3.5 Duration of Subject Participation.....                           | 62 |
| 9.4 Treatments.....  | 62 |
| 9.4.1 Treatments Administered .....                                    | 62 |
| 9.4.2 Identity of Investigational Product.....                         | 62 |
| 9.4.3 Storage.....   | 62 |
| 9.4.4 Directions for Administration .....                              | 63 |



---

|        |  |    |
|--------|--|----|
| 9.4.5  | Method of Assigning Subjects to Treatment Groups .....                 | 64 |
| 9.4.6  | Selection of Dose Used in the Study .....                              | 64 |
| 9.4.7  | Blinding .....   | 65 |
| 9.4.8  | Prior and Concomitant Medications .....                                | 65 |
| 9.5    | Treatment Compliance .....   | 68 |
| 9.6    | Investigational Product Accountability .....                           | 68 |
| 9.6.1  | Return and Disposition of Clinical Supplies .....                      | 68 |
| 9.7    | Dietary or Other Protocol Restrictions .....                           | 69 |
| 9.8    | Safety and Efficacy Variables .....                                    | 69 |
| 9.8.1  | Safety and Efficacy Measurements Assessed .....                        | 69 |
| 9.8.2  | Primary Efficacy Variables .....                                       | 69 |
| 9.8.3  | Secondary Efficacy Variables .....                                     | 70 |
| 9.8.4  | Tertiary Efficacy Variables .....                                      | 71 |
| 9.8.5  | Immunogenicity .....   | 72 |
| 9.8.6  | Pharmacodynamics .....   | 72 |
| 9.8.7  | Exploratory Assessments .....  | 72 |
| 9.8.8  | Safety Variables .....   | 73 |
| 10     | REPORTING ADVERSE EVENTS .....   | 81 |
| 10.1   | Safety Parameters and Definitions .....                                | 81 |
| 10.1.1 | Adverse Events .....   | 81 |
| 10.2   | Serious Adverse Events .....   | 82 |
| 10.2.1 | Events of Special Interest (EOSI) .....                                | 83 |
| 10.3   | Methods and Timing for Capturing and Assessing Safety Parameters ..... | 83 |
| 10.3.1 | Adverse Event Reporting Period .....                                   | 83 |
| 10.3.2 | Eliciting Adverse Events .....   | 83 |
| 10.3.3 | Assessment of Seriousness, Severity, and Causality .....               | 83 |
| 10.4   | Procedures for Recording Adverse Events .....                          | 86 |
| 10.4.1 | Recording Adverse Events on a eCRF .....                               | 86 |
| 10.5   | Reporting Requirements .....   | 89 |
| 10.5.1 | Expedited Reporting Requirements .....                                 | 89 |



|         |  |     |
|---------|--|-----|
| 10.5.2  | Institutional Review Board or Independent Ethics Committee Reporting Requirements..... | 90  |
| 10.6    | Follow-up of Subjects after Adverse Events.....  | 90  |
| 10.7    | Post-Study Adverse Events.....   | 90  |
| 10.8    | Urgent Safety Measures.....  | 91  |
| 10.9    | BioMarin Pharmacovigilance Contact Information.....                                    | 92  |
| 11      | APPROPRIATENESS OF MEASUREMENTS.....   | 93  |
| 12      | STUDY PROCEDURES.....  | 94  |
| 12.1    | Prestudy.....  | 94  |
| 12.2    | Screening Visit.....   | 94  |
| 12.2.1  | “Smart Rescreening” Visit.....   | 95  |
| 12.3    | Baseline Visit.....  | 96  |
| 12.4    | Treatment Visit/BMN 270 Infusion Visit (Day 1).....                                    | 97  |
| 12.5    | BMN 270 Infusion Follow-Up Visits – Weeks 1-26.....                                    | 98  |
| 12.5.1  | Once per week (Weeks 1 through 26).....  | 98  |
| 12.5.2  | Week 1 – Day 4.....  | 98  |
| 12.5.3  | Week 1 – Day 8.....  | 98  |
| 12.5.4  | Every 2 Weeks (Week 2, 4, 6, 8, 10, 12, 14, 16, 18, 20, 22, 24, and 26).....           | 99  |
| 12.5.5  | Weeks 2, 4, 10, 16, 22, and 26.....  | 99  |
| 12.5.6  | Weeks 2, 3, 4, 6, 8, 12, 16, 20, 24, and 26.....                                       | 99  |
| 12.5.7  | Weeks 4, 12, and 26.....   | 99  |
| 12.5.8  | Every 4 Weeks (Weeks 4, 8, 12, 16, 20, and 24) Plus Week 26.....                       | 99  |
| 12.5.9  | Every 8 Weeks (Weeks 8, 16, and 24).....   | 99  |
| 12.5.10 | Weeks 6, 13, 16, 20, 24, and 26.....   | 100 |
| 12.5.11 | Weeks 12 and 26.....   | 100 |
| 12.5.12 | Week 13 and 26.....  | 100 |
| 12.5.13 | Week 16.....   | 100 |
| 12.5.14 | Week 20, 24, and 26.....   | 100 |
| 12.6    | Post-Infusion Follow-Up – Weeks 27-52.....   | 101 |
| 12.6.1  | Every Visit.....   | 101 |



|        |   |     |
|--------|---|-----|
| 12.6.2 | Weeks 28, 30, 32, 34, 36, 44, and 52 .....  | 101 |
| 12.6.3 | Every 4 Weeks (Weeks 28, 32, 36, 40, 44, 48, 52) .....                              | 101 |
| 12.6.4 | Weeks 32, 36, 44, and 52 .....  | 102 |
| 12.6.5 | Weeks 32, 36, 40, 44, 48, and 52 .....  | 102 |
| 12.6.6 | Week 32, 36, and 52 .....   | 102 |
| 12.6.7 | Week 38 and 52 .....  | 102 |
| 12.6.8 | Week 52 .....   | 102 |
| 12.7   | Post-Infusion Follow-Up – Years 2-5 .....   | 103 |
| 12.7.1 | Year 2 – Every 4 Weeks (not required for treatment failure) .....                   | 103 |
| 12.7.2 | Years 3-5 – Every 6 Weeks (not required for treatment failure) .....                | 104 |
| 12.7.3 | Years 2-5 – Every 12 Weeks and End of Year Visits (required for all subjects) ..... | 105 |
| 12.8   | Early Termination Visit .....   | 107 |
| 12.9   | End of Study .....  | 108 |
| 13     | DATA QUALITY ASSURANCE .....  | 110 |
| 14     | STATISTICAL METHODS AND DETERMINATION OF SAMPLE SIZE .....                          | 111 |
| 14.1   | Statistical and Analytical Plans .....  | 111 |
| 14.1.1 | Interim Analyses .....  | 111 |
| 14.1.2 | Procedures for Accounting for Missing, Unused and Spurious Data .....               | 111 |
| 14.2   | Primary Efficacy Endpoint .....   | 111 |
| 14.3   | Secondary Efficacy Endpoints .....  | 112 |
| 14.4   | Immunogenicity .....  | 113 |
| 14.5   | Pharmacodynamic Analyses .....  | 113 |
| 14.6   | Safety Analysis .....   | 113 |
| 14.7   | Determination of Sample Size .....  | 114 |
| 14.8   | Analysis Populations .....  | 115 |
| 14.9   | Changes in the Conduct of the Study or Planned Analyses .....                       | 115 |
| 15     | DATA MONITORING COMMITTEE .....   | 116 |
| 16     | COSTS, COMPENSATION, AND SUBJECT INJURY .....                                       | 117 |
| 17     | CASE REPORT FORMS AND SOURCE DOCUMENTS .....  | 118 |
| 18     | STUDY MONITORING AND AUDITING .....   | 120 |



|      |   |     |
|------|---|-----|
| 19   | RETENTION OF RECORDS .....                              | 121 |
| 20   | USE OF INFORMATION AND PUBLICATION .....                | 122 |
| 21   | REFERENCES .....  | 123 |
| 22   | INVESTIGATOR RESPONSIBILITIES .....                     | 126 |
| 22.1 | Conduct of Study and Protection of Human Patients ..... | 126 |
| 23   | SIGNATURE PAGE .....                                    | 127 |
| 24   | APPENDIX 1: SAMPSON'S ANAPHYLAXIS CRITERIA .....        | 128 |
| 25   | PROTOCOL AMENDMENT TEXT REVISIONS .....                 | 129 |

## LIST OF TABLES

|                   |  |    |
|-------------------|--|----|
| Table 9.1.1:      | Schedule of Events – Screening and Infusion .....                        | 42 |
| Table 9.1.2:      | Schedule of Events – Post-Infusion Follow-Up (Week 1-16).....            | 45 |
| Table 9.1.3:      | Schedule of Events – Post-Infusion Follow-Up (Week 17-32).....           | 48 |
| Table 9.1.4:      | Schedule of Events – Post-Infusion Follow-Up (Week 33 – Week 52).....    | 51 |
| Table 9.1.5:      | Schedule of Events – Post-Infusion Follow-Up (Year 2 – Year 5).....      | 53 |
| Table 9.1.6:      | Schedule of Events – Therapeutic Corticosteroids for ALT Elevations..... | 56 |
| Table 9.4.8.2.1:  | Adjustments to Corticosteroid Regimen.....                               | 67 |
| Table 9.8.8.2.1:  | Clinical Laboratory Tests .....  | 74 |
| Table 9.8.8.3.1:  | Liver Tests .....  | 76 |
| Table 9.8.8.3.2:  | Evaluation of ALT Elevations .....                                       | 77 |
| Table 9.8.8.3.3:  | Viral and Autoimmune Hepatitis Testing.....                              | 78 |
| Table 10.3.3.2.1: | Adverse Event Grading (Severity) Scale.....                              | 84 |
| Table 10.3.3.3.1: | Causality Attribution Guidance .....                                     | 85 |

## LIST OF FIGURES

|               |   |    |
|---------------|---|----|
| Figure 7.3.1: | hFVIII-SQ Vector Genome Schematic ..... | 35 |
|---------------|---|----|





---

#### 4 LIST OF ABBREVIATIONS AND DEFINITIONS OF TERMS

|         |  |
|---------|--|
| AAV     | adeno-associated virus                                     |
| ABR     | annualized bleeding rate                                   |
| ADL     | activities of daily living                                 |
| ADR     | adverse drug reaction                                      |
| AE      | adverse event  |
| ALT     | alanine aminotransferase                                   |
| APTT    | activated partial thromboplastin time                      |
| ART     | anti-retroviral therapy                                    |
| AST     | aspartate aminotransferase                                 |
| BPV     | BioMarin Pharmacovigilance                                 |
| BU      | Bethesda Unit  |
| CFR     | Code of Federal Regulations                                |
| CRA     | clinical research associate                                |
| CRF     | case report form   |
| CSR     | clinical study report                                      |
| CTCAE   | Common Terminology Criteria for Adverse Events             |
| DMC     | Data Monitoring Committee                                  |
| eCRF    | electronic case report form                                |
| ED      | exposure days  |
| EOSI    | events of special interest                                 |
| ETV     | early termination visit                                    |
| EudraCT | European Union Drug Regulating Authorities Clinical Trials |
| FDA     | Food and Drug Administration                               |
| FIH     | first-in-human   |
| FVIII   | coagulation factor VIII                                    |
| GCP     | Good Clinical Practice                                     |
| GGT     | gamma-glutamyltransferase                                  |
| HA      | Hemophilia A   |
| HAL     | Haemophilia Activities List                                |
| HBcAb   | hepatitis B core antibody                                  |
| HBsAb   | hepatitis B surface antibody                               |
| HBsAg   | hepatitis B surface antigen                                |
| hFIX    | human coagulation factor IX                                |
| hFVIII  | human coagulation factor VIII                              |

---

|             |   |
|-------------|---|
| HIPAA       | Health Insurance Portability and Accountability Act   |
| IB          | investigator brochure   |
| ICF         | informed consent form   |
| ICH         | International Conference on Harmonisation of Technical Requirements for Registration of Pharmaceuticals for Human Use |
| ICH E6 [R2] | ICH Harmonised Tripartite Guideline: Guideline for Good Clinical Practice E6  |
| IEC         | independent ethics committee  |
| IND         | Investigational New Drug (application)  |
| INR         | international normalized ratio  |
| IP          | investigational product   |
| IRB         | institutional review board  |
| ITT         | Intention-to-treat  |
| IV          | intravenous   |
| LT          | liver test  |
| MedDRA      | Medical Dictionary for Regulatory Activities  |
| mITT        | Modified intention-to-treat   |
| MN          | mobile nursing  |
| PBMC        | peripheral blood mononuclear cells  |
| PCR         | polymerase chain reaction   |
| PD          | pharmacodynamics  |
| PEG         | polyethylene glycol   |
| PK          | Pharmacokinetics  |
| PRO         | patient-reported outcome  |
| rhFVIII     | recombinant human FVIII protein   |
| REB         | research ethics board   |
| SAE         | serious adverse event   |
| SAP         | statistical analysis plan   |
| SDV         | source data verification  |
| TGA         | thrombin generation assay   |
| ULN         | upper limit of normal   |
| vg          | vector genomes  |
| VWF:Ag      | von Willebrand factor Antigen   |
| WPAI+CIQ:HS | Work Productivity and Activity Impairment plus Classroom Impairment Questions: Hemophilia Specific                    |



**Definition of Terms:**

Investigational Product (IP):

“A pharmaceutical form of an active ingredient or placebo being tested or used as a reference in a clinical trial, including a product with a marketing authorization when used or assembled (formulated or packaged) in a way different from the approved form, or when used for an unapproved indication, or when used to gain further information about an approved use” (from International Conference on Harmonisation of Technical Requirements for Registration of Pharmaceuticals for Human Use ICH Harmonised Tripartite Guideline: Guideline for Good Clinical Practice E6 [ICH E6 (R2)]).

The terms “IP” and “study drug” may be used interchangeably in the protocol.



## 5 ETHICS

BioMarin Pharmaceutical Inc. (hereafter referred to as BioMarin or the Sponsor) conducts its studies according to the highest ethical and scientific standards. The following sections articulate standards to which Investigators will be held accountable, as well as matters of compliance to document adherence to such standards.

### 5.1 Institutional Review Board or Independent Ethics Committee

Investigators are expected to interact with Ethics Committees (ECs) promptly, as required, during the course of the study. This includes, but is not limited to, providing appropriate documentation to support study initiation and maintaining appropriate flow of safety and other information during the course of the study and for study close-out activities. BioMarin (or designee) will assist Investigators with access to timely and accurate information and with assurance of prompt resolution of any queries.

Prior to initiating the study, the Investigator will obtain written confirmation that the institutional review board (IRB) or independent ethics committee (IEC) [for Canadian protocols, Research Ethics Board (REB)] is properly constituted and compliant with International Conference on Harmonisation of Technical Requirements for Registration of Pharmaceuticals for Human Use (ICH) and Good Clinical Practice (GCP) requirements, applicable laws and local regulations. A copy of the confirmation from the IRB/IEC/REB will be provided to BioMarin or its designee. The Investigator will provide the IRB/IEC/REB with all appropriate material, including the protocol, Investigator's Brochure (IB), the Informed Consent Form (ICF) including compensation procedures, and any other written information provided to the subjects, including all ICFs translated for patients who do not speak the local language at the clinical site. The study will not be initiated and Investigational Product (IP) supplies will not be shipped to the site until appropriate documents from the IRB/IEC/REB confirming unconditional approval of the protocol, the ICF and all subject recruitment materials are obtained in writing by the Investigator and copies are received at BioMarin or its designee. The approval document should refer to the study by protocol title and BioMarin protocol number (if possible), identify the documents reviewed, and include the date of the review and approval. BioMarin will ensure that the appropriate reports on the progress of the study are made to the IRB/IEC/REB and BioMarin by the Investigator in accordance with applicable guidance documents and governmental regulations.

### 5.2 Ethical Conduct of Study

It is expected that Investigators understand and comply with the protocol. This includes, but is not limited to: establishing and meeting enrollment commitments, including providing



eligible subjects for study enrollment; adhering to adverse event reporting, diagnostic, or other procedures as specified in the protocol; and assuring appropriate compliance with study treatment administration and accountability.

This study will be conducted in accordance with the following:

- European Clinical Trial Directive 2001/20/EC and Good Clinical Practice Directive 2005/28/EC, for studies conducted within any European country
- US Code of Federal Regulations (CFR) sections that address clinical research studies, and/or other national and local regulations, as applicable
- ICH Harmonised Tripartite Guideline: Guideline for Good Clinical Practice E6 (ICH E6) or E6(R2) (ICH E6R2) if adopted

Specifically, this study is based on adequately performed laboratory and animal experimentation and human Phase 1 study testing. The study will be conducted under a protocol reviewed and approved by an IRB/IEC/REB and will be conducted by scientifically and medically qualified persons. The potential benefits of the study are in proportion to the potential risks. The rights and welfare of the subjects will be respected and the Investigators conducting the study do not find the hazards to outweigh the potential benefits. Each subject will provide written, informed consent before any study-related tests or evaluations are performed.

### **5.3 Subject Information and Informed Consent**

A properly written and executed informed consent form (ICF), in compliance with ICH E6 (Section 4.8), United States Code of Federal Regulations (CFR) 21 CFR §50, European Clinical Trial Directive 2001/20/EC and Good Clinical Practice Directive 2005/28/EC, and other applicable local regulations, will be obtained for each subject prior to entering the subject into the study. The Investigator will prepare the ICF and provide the documents to BioMarin for approval prior to submission to the IRB/IEC/REB. BioMarin and the IRB/IEC/REB must approve the documents before they are implemented. A copy of the approved ICF, and if applicable, a copy of the approved subject information sheet and all ICFs translated to a language other than the native language of the clinical site must also be received by BioMarin or designee prior to any study-specific procedures being performed.

The Investigator will provide copies of the signed ICF to each subject and will maintain the original in the record file of the subject.



---

## 6 INVESTIGATORS AND STUDY ADMINISTRATIVE STRUCTURE

During administration of informed consent, expectations regarding participation in the study should be made clear to subjects. Patients who are not willing and/or are not able to comply with all aspects of the study should not be encouraged to participate.

Prior to beginning the study, the Investigator at each site must provide to BioMarin or designee a fully executed and signed Statement of Investigator (SOI) form. A US Food and Drug Administration (FDA) Form FDA 1572 serves as an acceptable SOI form. If Form FDA 1572 may not be used in a particular region, the Investigator must provide a fully executed SOI on the form provided by the Sponsor. All Investigators and Sub-Investigators must be listed on Form FDA 1572 or its equivalent SOI. Financial Disclosure Forms must also be completed for all Investigators and Sub-Investigators listed on the Form FDA 1572 or SOI who will be directly involved in the treatment or evaluation of subjects in this study.

The study will be administered by and monitored by employees or representatives of BioMarin. Clinical research associates (CRAs) or trained designees will monitor each site on a periodic basis and perform verification of source documentation for each subject as well as other required review processes. BioMarin's Regulatory Affairs Department (or designee) will be responsible for the timely reporting of serious adverse events (SAEs) to appropriate regulatory authorities as required.

In multicenter studies, a Coordinating Investigator will be identified who will be responsible for study overview. The Coordinating Investigator will read the clinical study report (CSR) and confirm that it accurately describes the conduct and results of the study, to the best of his or her knowledge. The Coordinating Investigator will be chosen on the basis of active participation in the study, ability to interpret data, and willingness to review and sign the report in a specified timeframe. The identity of the Coordinating Investigator and a list of all Investigators participating in the study will be provided in the CSR.

Clinical Laboratory assessments will be performed at a nominated central laboratory. Bioanalytical samples will be sent to the appropriate specialty laboratories for testing. Refer to laboratory manual for more details.

## 7 INTRODUCTION

Hemophilia A (HA) is an X-linked recessive bleeding disorder that affects approximately 1 in 5,000 males (Nathwani, 1992, *Baillieres Clin.Haematol.*). It is caused by mutations in the factor VIII (FVIII) gene that codes for FVIII protein, an essential cofactor in the coagulation pathway. Clinical manifestations of severe FVIII deficiency are frequent unprovoked bleeding episodes in joints and soft tissues causing permanent disability and occasionally death mostly after brain hemorrhage. Treatment in Western countries (Berntorp, 2012, *Haemophilia.*) consists of intravenous injection of plasma-derived or recombinant FVIII protein concentrates at the time of a bleed to control it or prophylactically to prevent bleeding episodes. The short half-life for FVIII (~8-12 hours) necessitates frequent infusions and makes this treatment prohibitively expensive for the majority of the world's hemophilia A patients. These individuals develop debilitating arthropathy and have a substantially increased risk of death from hemorrhage in life (Stonebraker, 2010, *Haemophilia.*). Chemical modification or bioengineering of FVIII may improve half-life to 18-19 hours (Kaufman, 2013, *Blood*). However, these extended half-life FVIII variants do not eliminate the need for lifelong FVIII protein administration (Hay, 2012, *Blood*).

Gene therapy offers the potential of disease-modifying therapy by continuous endogenous production of human FVIII (hFVIII) following a single administration of vector. Hemophilia A is well-suited for this approach because its clinical manifestations are attributable to the lack of a single gene product (FVIII) that circulates in low amounts (100-200 ng/ml) in the plasma. Tightly regulated control of gene expression is not essential, and a modest increase in the level of FVIII (a plasma level of 2 ng/ml protein leads to a 1% expression) can ameliorate the severe phenotype (Srivastava, 2013, *Haemophilia.*); thus, the therapeutic goal for gene therapy is a modest increase in hFVIII. Finally, the consequences of gene transfer can be assessed using simple quantitative rather than qualitative endpoints that can be easily assayed in most clinical laboratories.

BMN 270 contains the cDNA for the B-domain-deleted SQ FVIII with a liver-specific HLP transcription promoter. The expression cassette is inserted between AAV2 ITRs, and this genome is packaged in the AAV5 capsid. A comprehensive review of BMN 270 is contained in the IB supplied by BioMarin. Investigators are to review this document prior to initiating this study.

### 7.1 Nonclinical Studies

The nonclinical program supports a single IV infusion of BMN 270, the planned clinical route of administration, for the treatment of hemophilia A in male patients. This nonclinical



program took into account the guidelines and reflection papers for gene therapy medicinal products under EMA Advanced Therapies as well as FDA guidance. The primary pharmacodynamics (PD), pharmacokinetics (PK), and toxicity of IV BMN 270 were characterized in a series of single dose studies in species that were vector permissive and responsive to the transgene including normal CD-1 mice, a B- and T-cell deficient mouse model of hemophilia A (B6;129S-*Fcγ2m1Kaz*/J x B6.129S6-*Rag2<sup>tm1Fwa</sup>* N12; FVIII KO x Rag2), and normal cynomolgus and rhesus monkeys. Some PD studies evaluated additional PK, immunogenicity and toxicity endpoints.

Results of the nonclinical program to date are detailed in the IB supplied by BioMarin. Investigators are to review this document prior to initiating this study.

## 7.2 Previous Clinical Studies

Study BMN 270-201 is an ongoing Phase 1/2, dose-escalation study to assess the safety, tolerability, and efficacy of BMN 270 in patients with severe hemophilia A (FVIII  $\leq 1$  IU/dL). Subjects received a single BMN 270 infusion and are to be followed for safety and efficacy for up to 5 years. A total of 15 subjects have been enrolled at one of 4 dose levels (6E12, 2E13, 4E13, and 6E13 vg/kg).

A comprehensive review of safety, efficacy, and immunogenicity results from 270-201 as of the latest data cut is contained in the IB supplied by BioMarin. Investigators are to review this document prior to initiating this study.

## 7.3 Study Rationale

Hemophilia A (HA) is an X-linked recessive bleeding disorder that affects approximately 1 in 5,000 males. It is caused by deficiency in the activity of coagulation factor VIII (FVIII), an essential cofactor in the intrinsic coagulation pathway. This disorder can be either inherited, due to a genetic aberrancy or an acquired immunologic process, leading to insufficient quantities of FVIII or a dysfunctional FVIII, but all are characterized by a defective coagulation process. The clinical phenotype of HA patients generally correlates tightly with the level of residual expression. Severe HA is classified as FVIII activity less than 1% of wild type ( $< 1$  IU/dL), moderate disease comprises 1-5% of wild-type activity and the mild form is 5-40% activity. The clinical manifestations of severe HA are frequent spontaneous bleeding episodes, predominantly in joints and soft tissues, with a substantially increased risk of death from hemorrhage when the brain is involved. Subjects with moderate disease can exhibit manifestations similar to those seen in patients with severe HA, resulting in a comparable bleeding phenotype.





Treatment of severe HA presently consists of intravenous injection of plasma derived or recombinant human FVIII protein (rhFVIII) concentrates both as prophylaxis 2-3 times per week, and at the time of a bleed, to prevent or control bleeding episodes, respectively. The half-life for FVIII (12 to 18 hours for most approved products) necessitates frequent infusions, and although a major advance in the treatment of HA, it remains common for severe HA patients to continue to have multiple bleeding events on prophylactic therapy (median ABR of 1-4 with prophylaxis treatment in a recently published retrospective observational study (Berntorp, 2017) and between 1-2 in 6 prospective FVIII interventional studies) and on-demand-only therapy (median ABR of 4.5-18 in a recently published retrospective study (Berntorp, 2017) and between 20-60 in 6 prospective FVIII interventional studies). The consequence of multiple bleeding events is the development of debilitating multiple-joint arthropathy and substantially increased risk of death. Chemical modification (eg, direct conjugation of polyethylene glycol (PEG) polymers) and bioengineering of FVIII (eg, FVIII-Fc fusion proteins) improve half-life by approximately 50%, and thus, show promise in reduced dosing and maintaining activity levels above 1% trough for a greater proportion of the dosing interval. However, these extended half-life FVIII variants remain dependent on multiple infusions to maintain critical levels of FVIII activity in severe HA patients. There is therefore a strong unmet need for a fully preventive treatment of HA to give patients a FVIII level compatible with a normal and hemorrhage-free life.

Gene therapy offers the potential of disease-modifying therapy by continuous endogenous production of active FVIII following a single intravenous infusion of a vector encoding the appropriate gene sequence for long-term episomal expression. Hemophilia A is well-suited for a gene replacement approach because clinical manifestations are attributable to the lack of a single gene product (FVIII) that circulates in minute amounts (200 ng/ml) in the plasma. Tightly regulated control of gene expression is not essential, and even modest increases in the level of FVIII (any increase of the plasma level by 2 ng/ml induces an increase in activity of 1%) can ameliorate the severe form of the disease. Thus, relatively small changes in endogenous FVIII activity can result in clinically relevant improvements in disease phenotype. Finally, the circulating FVIII response to gene transduction can be assessed using validated quantitative rather than qualitative endpoints that are easily assayed using established laboratory techniques.

Several different gene transfer strategies for FVIII replacement have been evaluated, but adeno-associated viral (AAV) vectors show the greatest promise. They have an excellent and well-defined safety profile, and can direct long term transgene expression with tropism and promoter specificity for specific tissues such as the liver (for serotypes 2, 5 and 8 among

others). Indeed, an on-going gene therapy clinical trial for a related disorder, hemophilia B, has established that stable (median follow-up of 3.2 years) expression of human factor IX (hFIX) at levels that are sufficient for conversion of their bleeding phenotype from severe to moderate or mild is achievable following a single peripheral vein infusion of AAV8-hFIX vector. Several participants in this trial have been able to discontinue factor prophylaxis without suffering spontaneous hemorrhages, even when they undertook activities that previously resulted in bleeding. Thus, gene therapy treatment has resulted in a substantial improvement in their quality of life (Nathwani, 2014).

BMN 270 is an AAV5-based gene therapy vector that expresses the SQ form of hFVIII under the control of a hybrid human liver-specific promoter (Figure 7.3.1).

**Figure 7.3.1: hFVIII-SQ Vector Genome Schematic**

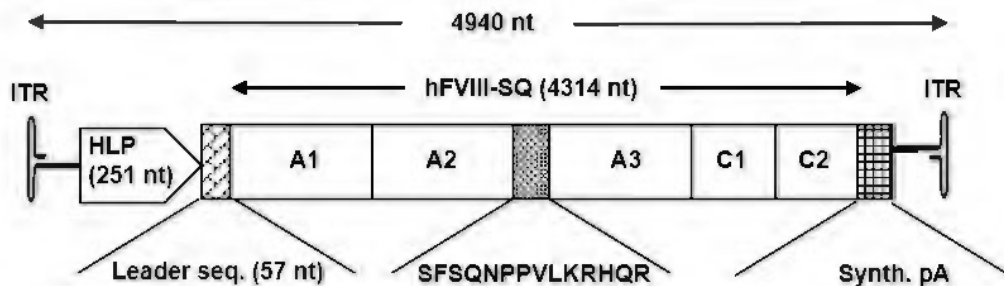

Legend –Note that schematic is not to scale; nt = nucleotides

BMN 270 will be delivered by a single intravenous dose and is designed to achieve stable, potentially life-long expression of active hFVIII in the plasma, synthesized from vector-transduced liver tissue.

BMN 270 is being evaluated in clinical study 270-201, an ongoing first-in-human, phase 1/2 dose escalation study in subjects with severe HA designed to assess the safety and efficacy of BMN 270 at various dose levels (6E12 vg/kg, 2E13 vg/kg, 4E13 vg/kg, 6E13 vg/kg).

Specifically, 270-201 explores the relationship of vector dose to the augmentation of residual FVIII activity and whether these levels are sufficient to alter the clinical phenotype.

Preliminary results from 270-201 have demonstrated that following gene transfer, FVIII activity above 15% (15 IU/dL) and, in many cases, within the normal range for FVIII, is achievable with a dose of 4-6E13 vg/kg with an acceptable safety profile (Pasi, 2017). For additional information on preliminary data in 270-201, refer to the current version of the Investigator's Brochure.

The current study is a Phase 3, single-arm, open-label study designed to assess whether, in an expanded sample, BMN 270 can safely alter the clinical phenotype of hemophilia A patients with residual FVIII activity  $\leq 1$  IU/dL.

#### 7.4 Summary of Overall Risks and Benefits

The majority of subjects in the ongoing 270-201 clinical study who have received 4E13 or 6E13 vg/kg doses of BMN 270 have had Grade 1 asymptomatic elevations in ALT. For most subjects, the elevations have reached only slightly above the ULN. Based on the effectiveness of transient oral corticosteroid used to suppress a presumed cytotoxic T-cell response in prior studies with hepatic transduction with AAV vectors (Mingozi, 2013), subjects were treated with 7-32 weeks of oral corticosteroids preventatively or in response to the elevations in ALT to ensure preservation of the transduced hepatocytes. Using this approach, no sustained loss of FVIII activity has been observed in subjects with ALT elevations, consistent with maintaining a high level of hepatocyte function. Moreover, the rise in ALT levels were not accompanied by significant or lasting aberrations in other liver tests such as AST, bilirubin or albumin, indicating that extent of toxicity is limited. There has been one HIV-positive subject in the ongoing 270-302 clinical study who experienced Grade 3 asymptomatic elevations in ALT and AST, which has been attributed to an interaction between one or more of his antiretroviral therapy medications and/or unsuspected underlying hepatic disease with BMN 270. In addition, there has been one subject with Gilbert's syndrome in the ongoing 270-301 clinical study who has experienced Grade 3 asymptomatic elevations in ALT and AST. These cases have led to the exclusion of subsequent HIV-positive subjects and requirement of liver tests at Screening that are  $<1.25$  times the upper limit of the normal range in the ongoing 270-301 and 270-302 clinical studies. Of note, two HIV-positive subjects in 270-301 and one presumed Gilbert's syndrome subject in 270-201 have received BMN 270 without experiencing any elevations in ALT to date. Overall, the literature and clinical experience with BMN 270 thus far suggest that transient elevations in liver enzymes are expected following AAV-based gene therapy for the treatment for hemophilia A or B without any long-term concerns of hepatic injury (Manno, 2006); (Nathwani, 2011); (George, 2016); (Miesbach, 2016); (Pasi, 2017).

At the highest dose tested in 270-201 (6E13 vg/kg), the majority of subjects achieved FVIII levels above 50 IU/dL at 52 weeks post-infusion. Subjects in that cohort also reported markedly decreased bleeding compared with pre-study rates and the ability to discontinue prophylactic FVIII infusions. Subjects at all dose levels continue to be followed.

As with any infused biological product, there is a potential risk of acute, systemic hypersensitivity reactions (including anaphylaxis) with BMN 270. No hypersensitivity



---

reactions were observed during dosing of BMN 270 in the 270-201 clinical study, although one SAE of pyrexia was reported approximately 16 hours after the infusion in a subject in the 4E13 vg/kg cohort. The subject was treated with acetaminophen, and the fever resolved within 48 hours (see Investigator's Brochure for full details). Infusion-related reactions, including allergic reaction, maculopapular rash, and presyncope, have been reported from ongoing, actively dosing clinical studies of BMN 270, including this study. All of the infusion-related reactions were effectively managed clinically and resolved without any clinical sequelae. Refer to the Investigator's Brochure for additional details.

The current data available for BMN 270 does not yet permit adequate assessment of the benefit:risk profile of this investigational drug. Given the monitoring measures in place in the clinical protocol(s) to minimize the risk to subjects participating in the existing studies, the identified risks are justified by the anticipated benefits that may be afforded to subjects. Each subject in 270-301 will have a comprehensive surveillance plan that monitors LTs during the study, and elevations in LTs will be addressed according to the guidelines set forth in the protocol. Safety will be assessed by adverse event reporting and clinical laboratory assessments.

For additional information on findings in 270-201, refer to the current version of the Investigator's Brochure.



## 8 STUDY OBJECTIVES

The primary efficacy objective of the study is to:

- Assess the efficacy of BMN 270 defined as FVIII activity, as measured by chromogenic substrate assay, during Weeks 49-52 following intravenous infusion of BMN 270

The secondary efficacy objectives of the study are to:

- Assess the impact of BMN 270 on usage of exogenous FVIII replacement therapy from Week 5 to Week 52
- Assess the impact of BMN 270 on the number of bleeding episodes requiring exogenous FVIII replacement therapy from Week 5 to Week 52

The tertiary efficacy objective of the study is to:

- Assess the impact of BMN 270 on patient-reported outcomes (PROs) at Week 52 of the study compared to baseline

The safety objectives of the study are to:

- Evaluate the safety of BMN 270 during the first 52 weeks following intravenous infusion
- Assess the long-term safety of BMN 270

## 9 INVESTIGATIONAL PLAN

### 9.1 Overall Study Design and Plan

This is a Phase 3, single-arm, open-label study in hemophilia A patients with residual FVIII levels  $\leq 1$  IU/dL treated continuously with prophylactic exogenous FVIII for a minimum of one year prior to enrollment. Subjects will be enrolled at approximately 60 sites worldwide. Subjects must have high-quality, well-documented historical data available concerning previous bleeding episodes and exogenous FVIII usage over the previous 12 months in order to be eligible to enroll in the study.

Approximately 130 adult subjects with severe HA will receive a 6E13 vg/kg dose of BMN 270 as a single intravenous infusion. Approximately 20 subjects will enroll in the study with at least 12 months of well-documented high-quality historical data concerning previous bleeding episodes and exogenous FVIII usage, while approximately 110 subjects will enroll in the study after having completed approximately 6 months' participation in the BioMarin-sponsored non-interventional study 270-902, in which bleeding and FVIII use data prior to gene therapy will be prospectively collected.

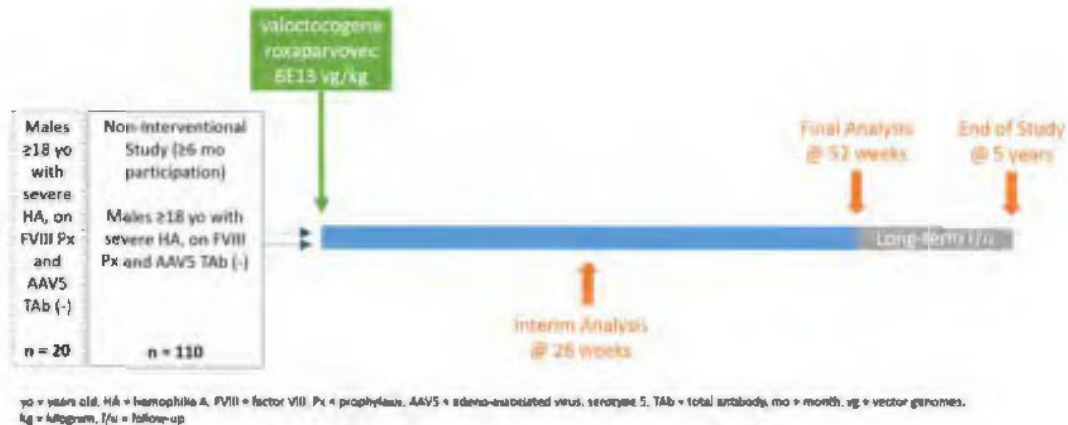

In order to minimize bias in the ongoing study and to assure safe and ethical conduct of the clinical trial, an independent Data Monitoring Committee (DMC), consisting of experts in clinical trials, statistics, and hemophilia, has been convened. The DMC will have sole access during the trial to amalgamated FVIII activity levels, FVIII usage, and bleeding data and will review available safety and efficacy (eg, FVIII activity) data during the study on an ongoing basis; they may determine, based on emerging data and the risk/benefit profile, that further enrollment at 6E13 vg/kg should be discontinued in favor of a different dose of BMN 270, not to exceed 6E13 vg/kg. If the DMC recommends a dosing modification, then additional



subjects may be enrolled, up to a total of approximately 130 subjects, at the new BMN 270 dose level (regardless of the number of subjects previously enrolled at 6E13 vg/kg).

An interim analysis is planned after 20 evaluable HIV-negative subjects have completed the Week 26 visit.

The final analysis for the study will be performed after all subjects have been followed for 52 weeks post-BMN 270 infusion. After the final analysis, safety and efficacy will then continue to be assessed long-term in all subjects for a total of approximately 5 years.

To avoid breakthrough bleeding, subjects will only discontinue exogenous prophylactic FVIII replacement therapy after 4 weeks following infusion of BMN 270. Four weeks represents the time by which endogenous production of FVIII following gene transfer is expected to be efficacious, based on earlier results.

As the relationship between activity assay results of the BMN 270 gene product and bleeding remains to be established, Investigators should strive to minimize bias by avoiding consideration of FVIII activity levels by themselves or subjects in the reporting of bleeding episodes and FVIII usage.

In subjects who experience recurrent bleeding episodes, the Investigator and Medical Monitor will discuss whether to resume prior FVIII prophylaxis.

Subjects who do not respond to BMN 270 treatment (ie, treatment failure, manifesting as either failure to achieve FVIII activity  $\geq 5$  IU/dL by Week 52 or inability to maintain independence from prophylactic FVIII replacement therapy due to joint bleeding episodes, in the judgment of the Investigator) may, at the Investigator's discretion and after discussion with the Medical Monitor, follow an abbreviated visit schedule after Week 52 of the study by attending only the Q12W and End of Year visits during Years 2-5.

There will be an ongoing review of individual subject safety by the Medical Monitor, and both safety and efficacy data by the DMC. Therapeutic oral corticosteroids may be initiated when a subject's ALT values are elevated, and subsequent dosage adjustments made, after consultation between the Investigator and the Medical Monitor. Management of ALT elevations is discussed in more detail in Section 9.8.8.3.

Any safety signal may trigger a review of the data and possible additional immunogenicity studies or other diagnostics deemed necessary that include an assessment of cellular immune responses using collected peripheral blood mononuclear cells (PBMCs).





---

Schedules of assessments for the Screening and Infusion period ([Table 9.1.1](#)), Post-Infusion follow-up periods ([Table 9.1.2](#), [Table 9.1.3](#), [Table 9.1.4](#), [Table 9.1.5](#)), and during the use of oral corticosteroids ([Table 9.1.6](#)) are presented below.



**Table 9.1.1: Schedule of Events – Screening and Infusion**

| Assessment  | Prior to BMN 270 Infusion      |  |  | BMN 270 Infusion Visit (Day 1) <sup>k</sup> |
|---|--------------------------------|--|--|---|
|   | Screening* (Day -28 to Day -1) | Smart Rescreening <sup>i</sup> (Day -28 to Day -1) | Baseline (Day -7 to Day -1) <sup>h</sup> |   |
| Informed consent  | X                              |  |  |   |
| Demographics (age, sex, race, ethnicity)  | X                              |  |  |   |
| Medical History   | X                              |  |  |   |
| Physical Examination <sup>a</sup>   | X                              |  | X  | X   |
| Height and Weight   | X                              |  |  |   |
| Vital Signs   | X                              | X  | X  | X   |
| Assessment of Adverse Events and Concomitant Medications  | X                              | X  | X  | X   |
| Documentation of bleeding episodes and FVIII usage for previous 12 months (by either subject or clinical information) | X                              | X  | X  |   |
| Distribution of subject diaries and training in their use <sup>l</sup>  | X                              |  |  |   |
| Electrocardiogram   | X                              |  |  |   |
| Liver Ultrasound  | X                              |  |  |   |
| hFVIII Assays <sup>b</sup>  | X                              | X <sup>j</sup>                                     | X  |   |
| AAV5 TAb Assays <sup>c</sup>  | X                              | X  | X  | X   |
| AAV5 TI Assay   |                                |  | X  |   |
| Screen for Hepatitis B, Hepatitis C, HIV <sup>d</sup>   | X                              |  |  |   |
| Blood chemistry, hematology, and coagulation tests <sup>e</sup>   | X                              | X  | X  |   |
| Fasting lipid panel (blood triglycerides, total cholesterol, HDL cholesterol, and LDL cholesterol)                    |                                |  |  | X   |
| Urine Tests <sup>e</sup>  | X                              | X  | X  |   |
| Liver Tests <sup>e</sup>  | X                              | X  | X  |   |
| PBMC collection (for baseline determination of AAV5 and FVIII specific cellular immunity)                             |                                |  | X  |   |



| Assessment   | Prior to BMN 270 Infusion      |  |  | BMN 270 Infusion Visit (Day 1) <sup>k</sup> |
|--|--------------------------------|--|--|---|
|  | Screening* (Day -28 to Day -1) | Smart Rescreening <sup>i</sup> (Day -28 to Day -1) | Baseline (Day -7 to Day -1) <sup>h</sup> |   |
| Von Willebrand Factor Antigen (VWF:Ag)                       |                                |  | X  |   |
| Direct Thrombin Activity Test <sup>g</sup>                   |                                |  | X  |   |
| TGA Assay <sup>g</sup>                                       |                                |  | X  |   |
| PCR of vector DNA in blood, saliva, urine, semen, and stools |                                |  | X  | X   |
| Biomarker testing <sup>f</sup>                               | X                              |  |  |   |
| Exploratory biomarker assessments <sup>g</sup>               |                                |  | X  | X   |
| Haemo-QOL-A assessment                                       |                                |  | X  |   |
| EQ-5D-5L   |                                |  | X  |   |
| HAL  |                                |  | X  |   |
| WPAI+CIQ:HS  |                                |  | X  |   |
| PROBE  |                                |  | X  |   |
| BMN 270 Infusion   |                                |  |  | X   |
| Hypersensitivity blood assessments <sup>m</sup>              |                                |  |  | X <sup>m</sup>                              |

\* Screening assessments should be performed within 28 days of BMN 270 infusion (and must be performed within 42 days prior to BMN 270 infusion).

<sup>a</sup> Complete physical examination should be done at Screening. Brief physical examination may be done at Baseline and at the BMN 270 Infusion Visit.

<sup>b</sup> Includes baseline FVIII activity (chromogenic substrate FVIII assay and one-stage clotting FVIII assay), coagulation exploratory assay, hFVIII inhibitor level (Bethesda assay with Nijmegen modification), hFVIII total antibody titer, and hFVIII protein assay. Baseline activity should be assessed at trough (at least >72 hours after last dose of replacement FVIII therapy, or 5x the known half-life of the FVIII concentrates administered).

<sup>c</sup> Sample collection on the day of the infusion visit must be performed before the BMN 270 infusion is given. Screening, Smart Re-screening, and Infusion Day samples will be tested in an AAV5 TAB pre-screening assay specifically developed for enrolment purposes. Baseline and all post-dose samples will be tested in a different AAV5 TAB post-dose immunogenicity monitoring assay

<sup>d</sup> Patients with documented negative results within the last 30 days do not need to be retested. Hepatitis B screening should include hepatitis B surface antigen (HBsAg), hepatitis B surface antibody (HBsAb), and hepatitis B core antibody (HBcAb).

<sup>e</sup> Refer to [Table 9.8.8.2.1](#) for laboratory assessments to be included, and to [Table 9.8.8.3.1](#) for liver tests.

<sup>f</sup> Includes HLA genotyping and FVIII genotyping.



- 
- <sup>g</sup> Blood samples will be collected to evaluate biochemical, molecular, cellular, ABO blood typing, and genetic/genomic aspects relevant to hemophilia A, coagulation, and/or AAV gene transfer, and to develop assays used for these evaluations. Subjects may choose to opt out of the exploratory genetic/genomic research being done to study or try to discover genes that are not yet known to be associated with hemophilia A. While exploratory samples will be collected at the time points indicated above, testing of these samples (including those for TGA assay, Direct Thrombin Activity test, and any other exploratory assessments) will be performed only as deemed necessary by the Sponsor.
- <sup>h</sup> Should the screening visit occur within 30 days of the drug infusion, physical examination, blood chemistry, LTs, hematology, urine tests, and coagulation tests do not need to be repeated at Baseline.
- <sup>i</sup> Smart rescreening should only be performed if a patient has been determined to be eligible for the study and is unable to complete the Baseline assessments and Infusion prior to the closing of the original Screening window. Subjects who undergo smart rescreening must complete the rescreening assessments and receive the infusion within 90 days of signing the original consent. Subjects who do not complete dosing within 90 days will be required to re-consent and undergo all screening procedures. Subjects may not undergo smart rescreening more than once.
- <sup>j</sup> Only the hFVIII inhibitor level (Bethesda assay with Nijmegen modification) assay must be done at smart rescreening.
- <sup>k</sup> With the exception of the collection of samples for PCR vector DNA analysis, assessments on the day of infusion must be performed prior to the infusion. Subjects will fast for at least 8 hours prior to pre-infusion laboratory sampling on the day of the infusion visit. On the day of the BMN 270 Infusion, vital signs will be monitored prior to the infusion, during the infusion every 15 minutes ( $\pm$  5 minutes), and following the infusion hourly ( $\pm$  5 minutes) for at least 8 hours during the subject's stay in the clinic. Shedding samples for PCR of vector DNA analysis (blood, saliva, urine, semen, stool) should be collected between 2 and 24 hours after the infusion has been completed.
- <sup>l</sup> Diaries should be distributed to subjects who have consented to participate in the study and who have been determined to meet all study eligibility criteria.
- <sup>m</sup> In case of hypersensitivity or adverse drug reaction, safety assessment, including physical examination and vital signs, will be done and additional blood samples will be collected within 1 hour of the hypersensitivity reaction (eg, tryptase, C3, C3a, C4, C5, C5a, and cytokine bead array, as well as possible additional exploratory testing) and samples for IgE and cytokine bead array (and possible additional exploratory testing) between 8-24 hours after the reaction, if possible. In addition, a blood sample should be taken 1 week after the hypersensitivity reaction for assessment of the cytokine bead array. In-patient observation can be extended and additional blood samples can be collected if deemed necessary at the discretion of the Investigator and Medical Monitor.

**Table 9.1.2: Schedule of Events – Post-Infusion Follow-Up (Week 1-16)**

| Assessment  | Follow-Up After BMN 270 Infusion – Weeks* |    |    |    |    |    |    |    |    |    |    |    |    |    |    |     |     |
|---|---|----|----|----|----|----|----|----|----|----|----|----|----|----|----|-----|-----|
|   | Week 1                                    |    | 2  | 3  | 4  | 5  | 6  | 7  | 8  | 9  | 10 | 11 | 12 | 13 | 14 | 15  | 16  |
|   | D4  | D8 |    |    |    |    |    |    |    |    |    |    |    |    |    |     |     |
| Study Day*  | 4   | 8  | 15 | 22 | 29 | 36 | 43 | 50 | 57 | 64 | 71 | 78 | 85 | 92 | 99 | 106 | 113 |
| Physical examination <sup>a</sup>   |   | X  | X  | X  | X  | X  | X  | X  | X  | X  | X  | X  | X  | X  | X  | X   | X   |
| Weight <sup>a</sup>   |   |    |    |    | X  |    |    |    | X  |    |    |    | X  |    |    |     | X   |
| Assessment of Adverse Events and Concomitant Medications (including review of subject diary for bleeding and FVIII use) |   | X  | X  | X  | X  | X  | X  | X  | X  | X  | X  | X  | X  | X  | X  | X   | X   |
| Vital Signs   |   | X  | X  | X  | X  | X  | X  | X  | X  | X  | X  | X  | X  | X  | X  | X   | X   |
| Blood chemistry, hematology, and coagulation tests <sup>b</sup>   |   |    | X  |    | X  |    |    |    |    |    | X  |    |    |    |    |     | X   |
| Urine Tests <sup>b</sup>  |   |    |    |    |    |    |    |    |    |    |    |    | X  |    |    |     |     |
| Liver Tests <sup>b</sup>  | X   | X  | X  | X  | X  | X  | X  | X  | X  | X  | X  | X  | X  | X  | X  | X   | X   |
| FVIII assays <sup>c</sup>   |   | X  | X  | X  | X  | X  | X  | X  | X  | X  | X  | X  | X  | X  | X  | X   | X   |
| FVIII antibody titer  |   |    |    |    | X  |    |    |    | X  |    |    |    | X  |    |    |     | X   |
| PCR of vector DNA in blood, saliva, urine, semen, and stools <sup>d</sup>   | X   | X  | X  | X  | X  |    | X  |    | X  |    |    |    | X  |    |    |     | X   |
| Exploratory biomarker assessments <sup>e</sup>  |   |    |    |    |    |    | X  |    |    |    |    |    |    | X  |    |     | X   |
| Haemo-QOL-A assessment  |   |    |    |    | X  |    |    |    |    |    |    |    | X  |    |    |     |     |
| EQ-5D-5L  |   |    |    |    | X  |    |    |    |    |    |    |    | X  |    |    |     |     |
| HAL   |   |    |    |    | X  |    |    |    |    |    |    |    | X  |    |    |     |     |



| Assessment  | Follow-Up After BMN 270 Infusion – Weeks* |    |    |    |    |    |    |    |    |    |    |    |    |    |    |     |                |
|---|---|----|----|----|----|----|----|----|----|----|----|----|----|----|----|-----|----------------|
|   | Week 1                                    |    | 2  | 3  | 4  | 5  | 6  | 7  | 8  | 9  | 10 | 11 | 12 | 13 | 14 | 15  | 16             |
|   | D4  | D8 |    |    |    |    |    |    |    |    |    |    |    |    |    |     |                |
| Study Day*  | 4   | 8  | 15 | 22 | 29 | 36 | 43 | 50 | 57 | 64 | 71 | 78 | 85 | 92 | 99 | 106 | 113            |
| WPAI+CIQ:HS   |   |    |    |    | X  |    |    |    |    |    |    |    | X  |    |    |     |                |
| PROBE   |   |    |    |    | X  |    |    |    |    |    |    |    | X  |    |    |     |                |
| AAV5 Tab Assay  |   |    |    |    |    |    |    |    | X  |    |    |    |    |    |    |     | X              |
| AAV5 TI Assay   |   |    |    |    |    |    |    |    | X  |    |    |    |    |    |    |     | X              |
| Testing for reactivation of hepatitis B and hepatitis C                 |   |    |    |    |    |    |    |    |    |    |    |    |    |    |    |     | X <sup>f</sup> |
| PBMC collection (for determination of AAV5 and FVIII specific immunity) |   |    | X  |    | X  |    | X  |    | X  |    | X  |    | X  |    | X  |     | X              |
| VWF:Ag  |   |    |    |    |    |    |    |    |    |    |    |    |    | X  |    |     |                |
| Direct Thrombin Activity test <sup>c</sup>                              |   |    |    |    |    |    |    |    |    |    |    |    |    | X  |    |     |                |

\* Visit windows are ± 48 hours (and include the Day 4 visit).

<sup>a</sup> Brief physical examination should be done at all weekly visits.

<sup>b</sup> Refer to [Table 9.8.8.2.1](#) for laboratory assessments to be included, and to [Table 9.8.8.3.1](#) for liver tests (LTs). LTs may be monitored more or less frequently (and in particular when ALT values are  $\geq 1.5x$  ULN or  $> ULN$  &  $> 2x$  baseline value) based on discussion between the Medical Monitor and the Investigator and review of subject data, but LTs will be monitored at least twice weekly during periods when a subject's ALT is  $\geq 3x$  ULN. Subjects with ALT  $> 1.5x$  ULN or  $> ULN$  &  $> 2x$  baseline value during the study and either an alternative etiology considered or for further evaluation of the lab abnormality may undergo additional evaluations (eg, imaging studies including MRI or ultrasound, additional blood tests, and/or liver biopsy) at the discretion of the Investigator. Additional testing of FVIII and LTs during any study week may be performed if: (1) the ALT has increased to above ULN; (2) Increases in ALT values from prior assessment are accompanied by declines in FVIII activity level; or after a discussion between the Medical Monitor and the Investigator based on a review of subject data. If FVIII levels and/or ALT values are stable over the course of several weeks, assessment of FVIII activity and ALT levels may be adjusted based on discussion between the Medical Monitor and the Investigator.

<sup>c</sup> Includes FVIII activity level (chromogenic substrate FVIII assay and one-stage clotting FVIII assay), Bethesda assay (with Nijmegen modification) for hFVIII inhibitor level, coagulation exploratory assay, and hFVIII protein assay. If a subject has used FVIII within 72 hours of a measurement day, all efforts should be made to obtain FVIII activity measurements when a 72-hour interval without FVIII use is achieved; the 72-hour wash-out period is only intended for subjects who have achieved FVIII  $\geq 5$  IU/dL at 16 weeks after BMN 270 infusion and who have not resumed FVIII replacement therapy. If FVIII levels are elevated or stable over the course of several weeks, assessment of FVIII activity may be adjusted based on discussion



---

between the Medical Monitor and the Investigator. A D-dimer may be considered under circumstances in which FVIII activity levels are above the normal physiological range and/or if there is a concern for a venous thromboembolism.

- <sup>d</sup> Collection for each matrix to occur until at least 3 consecutive negative results are obtained. Collection and testing of semen samples must continue at least through Week 12, even if 3 consecutive negative results in that compartment have already been recorded.
- <sup>e</sup> Blood samples will be collected to evaluate biochemical, molecular, cellular, and genetic/genomic aspects relevant to hemophilia A, coagulation, and/or AAV gene transfer, and to develop assays used for these evaluations. Subjects may choose to opt out of the exploratory genetic/genomic research being done to study or try to discover genes that are not yet known to be associated with hemophilia A. While exploratory samples will be collected at the time points indicated above, testing of these samples (including those for TGA assay, Direct Thrombin Activity test, and any other exploratory assessments) will be performed only as deemed necessary by the Sponsor.
- <sup>f</sup> Testing for reactivation of hepatitis B and hepatitis C at Week 16, for subjects with a past medical history of hepatitis B or hepatitis C prior to study entry, should be performed only in subjects who have not received therapeutic oral corticosteroids prior to Week 16; subjects who have received therapeutic oral corticosteroids will have hepatitis B and hepatitis C testing at the time points indicated in [Table 9.1.6](#).

**Table 9.1.3: Schedule of Events – Post-Infusion Follow-Up (Week 17-32)**

| Assessment  | Follow-Up After BMN 270 Infusion – Weeks* |     |     |     |     |     |     |     |     |     |     |     |     |     |     |     |
|---|---|-----|-----|-----|-----|-----|-----|-----|-----|-----|-----|-----|-----|-----|-----|-----|
|   | 17  | 18  | 19  | 20  | 21  | 22  | 23  | 24  | 25  | 26  | 27  | 28  | 29  | 30  | 31  | 32  |
| Study Day*  | 120                                       | 127 | 134 | 141 | 148 | 155 | 162 | 169 | 176 | 183 | 190 | 197 | 204 | 211 | 218 | 225 |
| Physical examination <sup>a</sup>   | X   | X   | X   | X   | X   | X   | X   | X   | X   | X   | X   | X   | X   | X   | X   | X   |
| Weight <sup>a</sup>   |   |     |     | X   |     |     |     | X   |     |     |     | X   |     |     |     | X   |
| Assessment of Adverse Events and Concomitant Medications (including review of subject diary for bleeding and FVIII use) | X   | X   | X   | X   | X   | X   | X   | X   | X   | X   | X   | X   | X   | X   | X   | X   |
| Vital Signs   | X   | X   | X   | X   | X   | X   | X   | X   | X   | X   | X   | X   | X   | X   | X   | X   |
| Blood chemistry, hematology, and coagulation tests <sup>b</sup>   |   |     |     |     |     | X   |     |     |     | X   |     |     |     |     |     | X   |
| Urine Tests <sup>b</sup>  |   |     |     |     |     |     |     |     |     | X   |     |     |     |     |     |     |
| Liver Tests <sup>b</sup>  | X   | X   | X   | X   | X   | X   | X   | X   | X   | X   | X   | X   | X   | X   | X   | X   |
| FVIII assays <sup>c</sup>   | X   | X   | X   | X   | X   | X   | X   | X   | X   | X   | X   | X   | X   | X   | X   | X   |
| FVIII antibody titer  |   |     |     | X   |     |     |     | X   |     | X   |     |     |     |     |     | X   |
| PCR of vector DNA in blood, saliva, urine, semen, and stools <sup>d</sup>   |   |     |     | X   |     |     |     | X   |     | X   |     |     |     |     |     | X   |
| Exploratory biomarker assessments <sup>e</sup>  |   |     |     | X   |     |     |     | X   |     | X   |     |     |     |     |     | X   |



| Assessment   | Follow-Up After BMN 270 Infusion – Weeks* |     |     |     |     |     |     |     |     |     |     |     |     |     |     |     |
|--|---|-----|-----|-----|-----|-----|-----|-----|-----|-----|-----|-----|-----|-----|-----|-----|
|  | 17  | 18  | 19  | 20  | 21  | 22  | 23  | 24  | 25  | 26  | 27  | 28  | 29  | 30  | 31  | 32  |
| Study Day*   | 120                                       | 127 | 134 | 141 | 148 | 155 | 162 | 169 | 176 | 183 | 190 | 197 | 204 | 211 | 218 | 225 |
| Haemo-QOL-A assessment   |   |     |     |     |     |     |     |     |     | X   |     |     |     |     |     |     |
| EQ-5D-5L   |   |     |     |     |     |     |     |     |     | X   |     |     |     |     |     |     |
| HAL  |   |     |     |     |     |     |     |     |     | X   |     |     |     |     |     |     |
| WPAI+CIQ:HS  |   |     |     |     |     |     |     |     |     | X   |     |     |     |     |     |     |
| PROBE  |   |     |     |     |     |     |     |     |     | X   |     |     |     |     |     |     |
| AAV5 TAb Assay   |   |     |     |     |     |     |     | X   |     |     |     |     |     |     |     | X   |
| AAV5 TI Assay  |   |     |     |     |     |     |     | X   |     |     |     |     |     |     |     | X   |
| PBMC collection (for determination of AAV5 and FVIII specific cellular immunity) |   | X   |     | X   |     | X   |     | X   |     | X   |     | X   |     | X   |     | X   |
| VWF:Ag   |   |     |     |     |     |     |     |     |     | X   |     |     |     |     |     |     |
| Direct Thrombin Activity Test <sup>c</sup>                                       |   |     |     |     |     |     |     |     |     | X   |     |     |     |     |     |     |
| TGA Assay <sup>c</sup>   |   |     |     | X   |     |     |     | X   |     | X   |     |     |     |     |     | X   |

\* Visit windows are  $\pm$  48 hours.

<sup>a</sup> Brief physical examination should be done at all weekly visits except Week 26, where a complete physical examination should be performed. Weight should be recorded at Week 20 and every 4 weeks.

<sup>b</sup> Refer to [Table 9.8.8.2.1](#) for laboratory assessments to be included, and to [Table 9.8.8.3.1](#) for liver tests (LTs). LTs may be monitored more or less frequently (and in particular when ALT values are  $\geq 1.5x$  ULN or  $> ULN$  &  $> 2x$  baseline value) based on discussion between the Medical Monitor and the Investigator and review of subject data, but LTs will be monitored at least twice weekly during periods when a subject's ALT is  $\geq 3x$  ULN. Subjects with ALT  $\geq 1.5x$  ULN or  $> ULN$  &  $> 2x$  baseline value during the study and either an alternative etiology considered or for further evaluation of the lab abnormality may undergo additional evaluations (eg, imaging studies including MRI or ultrasound, additional blood tests, and/or liver biopsy) at the discretion of the Investigator. Additional testing of FVIII and LTs during any study week may be performed if: (1) the ALT has increased to above ULN; (2) Increases in ALT values from prior assessment are accompanied by declines in FVIII activity level; or after a discussion between the Medical Monitor and the Investigator based on a review of subject





---

data. If FVIII levels and/or ALT values are stable over the course of several weeks, assessment of FVIII activity and ALT levels may be adjusted based on discussion between the Medical Monitor and the Investigator.

<sup>c</sup> Includes FVIII activity level (chromogenic substrate FVIII assay and one-stage clotting FVIII assay), Bethesda assay (with Nijmegen modification) for hFVIII inhibitor level, coagulation exploratory assay, and hFVIII protein. If a subject has used FVIII within 72 hours of a measurement day, all efforts should be made to obtain FVIII activity measurements when a 72-hour interval without FVIII use is achieved; the 72-hour wash-out period is only intended for subjects who have achieved FVIII  $\geq 5$  IU/dL at 16 weeks after BMN 270 infusion and who have not resumed FVIII replacement therapy. If FVIII levels are elevated or stable over the course of several weeks, assessment of FVIII activity may be adjusted based on discussion between the Medical Monitor and the Investigator. A D-dimer may be considered under circumstances in which FVIII activity levels are above the normal physiological range and/or if there is a concern for a venous thromboembolism.

<sup>d</sup> Collection for each matrix to occur until at least 3 consecutive negative results are obtained.

<sup>e</sup> Blood samples will be collected to evaluate biochemical, molecular, cellular, and genetic/genomic aspects relevant to hemophilia A, coagulation, and/or AAV gene transfer, and to develop assays used for these evaluations. Subjects may choose to opt out of the exploratory genetic/genomic research being done to study or try to discover genes that are not yet known to be associated with hemophilia A. While exploratory samples will be collected at the time points indicated above, testing of these samples (including those for TGA assay, Direct Thrombin Activity test, and any other exploratory assessments) will be performed only as deemed necessary by the Sponsor.

**Table 9.1.4: Schedule of Events – Post-Infusion Follow-Up (Week 33 – Week 52)**

| Assessment  | Year 1 – Weeks* |     |     |     |     |     |     |     |     |     |     |     |
|---|-----------------|-----|-----|-----|-----|-----|-----|-----|-----|-----|-----|-----|
|   | 33              | 34  | 35  | 36  | 38  | 40  | 42  | 44  | 46  | 48  | 50  | 52  |
| Study Day*  | 232             | 239 | 246 | 253 | 267 | 281 | 295 | 309 | 323 | 337 | 351 | 365 |
| Physical examination <sup>a</sup>   | X               | X   | X   | X   | X   | X   | X   | X   | X   | X   | X   | X   |
| Weight <sup>a</sup>   |                 |     |     | X   |     | X   |     | X   |     | X   |     | X   |
| Assessment of Adverse Events and Concomitant Medications (including review of subject diary for bleeding and FVIII use) | X               | X   | X   | X   | X   | X   | X   | X   | X   | X   | X   | X   |
| Vital Signs   | X               | X   | X   | X   | X   | X   | X   | X   | X   | X   | X   | X   |
| Blood chemistry, hematology, and coagulation tests <sup>b</sup>   |                 |     |     | X   |     |     |     | X   |     |     |     | X   |
| Urine Tests <sup>b</sup>  |                 |     |     |     | X   |     |     |     |     |     |     | X   |
| Liver Tests <sup>b</sup>  | X               | X   | X   | X   | X   | X   | X   | X   | X   | X   | X   | X   |
| FVIII assays <sup>c</sup>   | X               | X   | X   | X   | X   | X   | X   | X   | X   | X   | X   | X   |
| AAV5 TAb Assay  |                 |     |     | X   |     |     |     |     |     |     |     | X   |
| AAV5 TI Assay   |                 |     |     | X   |     |     |     |     |     |     |     | X   |
| FVIII antibody titer  |                 |     |     | X   |     |     |     | X   |     |     |     | X   |
| Exploratory biomarker assessments <sup>d</sup>  |                 |     |     | X   |     | X   |     | X   |     | X   |     | X   |
| PBMC Collection (for determination of FVIII and Capsid specific cellular immunity)                                      |                 | X   |     | X   |     |     |     | X   |     |     |     | X   |
| VWF:Ag  |                 |     |     |     | X   |     |     |     |     |     |     | X   |
| Direct Thrombin Activity Test <sup>d</sup>  |                 |     |     |     | X   |     |     |     |     |     |     | X   |
| TGA Assay <sup>d</sup>  |                 |     |     | X   |     | X   |     | X   |     | X   |     | X   |
| PCR of vector DNA in blood, saliva, urine, semen, and stools  |                 |     |     | X   |     | X   |     | X   |     | X   |     | X   |
| Haemo-QOL-A assessment  |                 |     |     |     |     |     |     |     |     |     |     | X   |
| EQ-5D-5L  |                 |     |     |     |     |     |     |     |     |     |     | X   |
| HAL   |                 |     |     |     |     |     |     |     |     |     |     | X   |



| Assessment  | Year 1 – Weeks* |    |    |    |    |    |    |    |    |    |    |    |
|-------------|-----------------|----|----|----|----|----|----|----|----|----|----|----|
|             | 33              | 34 | 35 | 36 | 38 | 40 | 42 | 44 | 46 | 48 | 50 | 52 |
| WPAI+CIQ:HS |                 |    |    |    |    |    |    |    |    |    |    | X  |
| PROBE       |                 |    |    |    |    |    |    |    |    |    |    | X  |

\* Visit windows are  $\pm$  48 hours through Week 36, then  $\pm$ 1 week until Week 52

<sup>a</sup> Complete physical examination should be performed at Week 52; brief physical exam may be performed at other study visits. Weight should be recorded at Week 36 and every 4 weeks through Week 52.

<sup>b</sup> Refer to [Table 9.8.8.2.1](#) for laboratory assessments to be included, and to [Table 9.8.8.3.1](#) for liver tests. LTs may be monitored more or less frequently (and in particular when ALT values are  $\geq 1.5x$  ULN or  $>$  ULN &  $>$  2x baseline value) based on discussion between the Medical Monitor and the Investigator and review of subject data, but LTs will be monitored at least twice weekly during periods when a subject's ALT is  $\geq 3x$  ULN. Subjects with ALT  $\geq 1.5x$  ULN or  $>$  ULN &  $>$  2x baseline value during the study and either an alternative etiology considered or for further evaluation of the lab abnormality may undergo additional evaluations (eg, imaging studies including MRI or ultrasound, additional blood tests, and/or liver biopsy) at the discretion of the Investigator. Additional testing of FVIII and LTs during any study week may be performed if: (1) the ALT has increased to above ULN or increased by  $>$  10 U/L from prior assessment; (2) Increases in ALT values from prior assessment are accompanied by declines in FVIII activity level; or after a discussion between the Medical Monitor and the Investigator based on a review of subject data. If FVIII levels and/or ALT values are stable over the course of several weeks, assessment of FVIII activity and ALT levels may be adjusted based on discussion between the Medical Monitor and the Investigator.

<sup>c</sup> Includes FVIII activity level (chromogenic substrate FVIII assay and one-stage clotting FVIII assay), Bethesda assay (with Nijmegen modification) for hFVIII inhibitor level, coagulation exploratory assay, and hFVIII protein assay. If a subject has used FVIII within 72 hours of a measurement day, all efforts should be made to obtain FVIII activity measurements when a 72-hour interval without FVIII use is achieved; the 72-hour wash-out period is only intended for subjects who have achieved FVIII  $\geq 5$  IU/dL at 16 weeks after BMN 270 infusion and who have not resumed FVIII replacement therapy. If FVIII levels are elevated or stable over the course of several weeks, assessment of FVIII activity may be adjusted based on discussion between the Medical Monitor and the Investigator. A D-dimer may be considered under circumstances in which FVIII activity levels are above the normal physiological range and/or if there is a concern for a venous thromboembolism.

<sup>d</sup> Blood samples will be collected to evaluate biochemical, molecular, cellular, and genetic/genomic aspects relevant to hemophilia A, coagulation, and/or AAV gene transfer, and to develop assays used for these evaluations. Subjects may choose to opt out of the exploratory genetic/genomic research being done to study or try to discover genes that are not yet known to be associated with hemophilia A. While exploratory samples will be collected at the time points indicated above, testing of these samples (including those for TGA assay, Direct Thrombin Activity test, and any other exploratory assessments) will be performed only as deemed necessary by the Sponsor.

**Table 9.1.5: Schedule of Events – Post-Infusion Follow-Up (Year 2 – Year 5)**

| Assessment  | Years 2-5*       | Year 2*          | Years 3-5*       | End of Year Visit |                  |                |                | ETV              |
|---|------------------|------------------|------------------|-------------------|------------------|----------------|----------------|------------------|
|   | Q12W             | Q4W <sup>g</sup> | Q6W <sup>g</sup> | Year 2<br>W104    | Year 3<br>W156   | Year 4<br>W208 | Year 5<br>W260 |                  |
| Study Week*   |                  |                  |                  |                   |                  |                |                |                  |
| Physical examination <sup>a</sup>   | X <sup>a</sup>   |                  |                  |                   | X <sup>a</sup>   |                |                | X                |
| Weight <sup>a</sup>   | X <sup>a</sup>   |                  |                  |                   | X <sup>a</sup>   |                |                | X                |
| Assessment of Adverse Events and Concomitant Medications (including review of subject diary for bleeding and FVIII use) | X                | X                | X                |                   | X                |                |                | X                |
| Vital Signs   | X                |                  |                  |                   | X                |                |                | X                |
| Blood chemistry, hematology, and coagulation tests <sup>b</sup>   | X <sup>b</sup>   |                  |                  |                   | X <sup>b</sup>   |                |                | X                |
| Urine Tests <sup>b</sup>  | X <sup>b</sup>   |                  |                  |                   | X <sup>b</sup>   |                |                | X                |
| Liver Tests <sup>b</sup>  | X                | X                | X                |                   | X                |                |                | X                |
| FVIII assays <sup>c</sup>   | X                | X                | X                |                   | X                |                |                | X                |
| AAV5 TAb Assay  | X                |                  |                  |                   | X                |                |                | X                |
| AAV5 TI Assay   | X                |                  |                  |                   | X                |                |                | X                |
| FVIII antibody titer  | X                |                  |                  |                   | X                |                |                | X                |
| Exploratory biomarker assessments <sup>e</sup>  | X                |                  |                  |                   | X                |                |                | X                |
| PBMC Collection (for determination of FVIII and Capsid specific cellular immunity)                                      | X                |                  |                  |                   | X                |                |                | X                |
| VWF:Ag  | X                |                  |                  |                   | X                |                |                | X                |
| Direct Thrombin Activity Test <sup>e</sup>  | X                |                  |                  |                   | X                |                |                | X                |
| TGA Assay <sup>e</sup>  | X                |                  |                  |                   | X                |                |                | X                |
| PCR of vector DNA in blood, saliva, urine, semen, and stools <sup>d</sup>   | (X) <sup>d</sup> | (X) <sup>d</sup> | (X) <sup>d</sup> |                   | (X) <sup>d</sup> |                |                | (X) <sup>d</sup> |
| Haemo-QOL-A assessment  | X <sup>f</sup>   |                  |                  |                   | X <sup>f</sup>   |                |                | X                |
| EQ-5D-5L  | X <sup>f</sup>   |                  |                  |                   | X <sup>f</sup>   |                |                | X                |
| HAL   | X <sup>f</sup>   |                  |                  |                   | X <sup>f</sup>   |                |                | X                |



| Assessment  | Years 2-5*     | Year 2*          | Years 3-5*       | End of Year Visit |                |                |                | ETV |
|-------------|----------------|------------------|------------------|-------------------|----------------|----------------|----------------|-----|
|             | Q12W           | Q4W <sup>g</sup> | Q6W <sup>g</sup> | Year 2<br>W104    | Year 3<br>W156 | Year 4<br>W208 | Year 5<br>W260 |     |
| Study Week* | Q12W           | Q4W <sup>g</sup> | Q6W <sup>g</sup> | W104              | W156           | W208           | W260           |     |
| WPAI+CIQ:HS | X <sup>f</sup> |                  |                  | X <sup>f</sup>    |                |                |                | X   |
| PROBE       | X <sup>f</sup> |                  |                  | X <sup>f</sup>    |                |                |                | X   |

\* Visit windows are  $\pm 2$  weeks for visits in Years 2-5. At applicable sites, the Q4W (during Year 2) and Q6W (during Years 3-5) assessments may be conducted by a trained mobile nursing (MN) professional at the subject's home or another suitable location, if the subject has given written informed consent to participate in mobile nursing visits. Q12W and End of Year visits during Years 2-5 cannot be done by a MN professional and must be done at the study site.

<sup>a</sup> Complete physical examination should be performed at the End of Year visits; brief physical exam may be performed at other study visits. Weight should be recorded at the second Q12W visit each year and at every End of Year visit during Years 2-5.

<sup>b</sup> Refer to [Table 9.8.8.2.1](#) for laboratory assessments to be included, and to [Table 9.8.8.3.1](#) for liver tests. LTs may be monitored more or less frequently (and in particular when ALT values are  $\geq 1.5x$  ULN or  $> ULN$  &  $> 2x$  baseline value) based on discussion between the Medical Monitor and the Investigator and review of subject data, but LTs will be monitored at least twice weekly during periods when a subject's ALT is  $\geq 3x$  ULN. Subjects with ALT  $\geq 1.5x$  ULN or  $> ULN$  &  $> 2x$  baseline value during the study and either an alternative etiology considered or for further evaluation of the lab abnormality may undergo additional evaluations (eg, imaging studies including MRI or ultrasound, additional blood tests, and/or liver biopsy) at the discretion of the Investigator. Additional testing of FVIII and LTs during any study week may be performed if: (1) the ALT has increased to above ULN or increased by  $> 10$  U/L from prior assessment; (2) Increases in ALT values from prior assessment are accompanied by declines in FVIII activity level; or after a discussion between the Medical Monitor and the Investigator based on a review of subject data. If FVIII levels and/or ALT values are stable over the course of several weeks, assessment of FVIII activity and ALT levels may be adjusted based on discussion between the Medical Monitor and the Investigator. During Years 2-5 of the Post-Infusion Follow-Up period, urine tests and blood, chemistry, and coagulation tests should be performed at the second Q12W visit each year and at every End of Year visit.

<sup>c</sup> Includes FVIII activity level (chromogenic substrate FVIII assay and one-stage clotting FVIII assay), Bethesda assay (with Nijmegen modification) for hFVIII inhibitor level, coagulation exploratory assay, and hFVIII protein assay. If a subject has used FVIII within 72 hours of a measurement day, all efforts should be made to obtain FVIII activity measurements when a 72-hour interval without FVIII use is achieved; the 72-hour wash-out period is only intended for subjects who have achieved FVIII  $\geq 5$  IU/dL at 16 weeks after BMN 270 infusion and who have not resumed FVIII replacement therapy. If FVIII levels are elevated or stable over the course of several weeks, assessment of FVIII activity may be adjusted based on discussion between the Medical Monitor and the Investigator. A D-dimer may be considered under circumstances in which FVIII activity levels are above the normal physiological range and/or if there is a concern for a venous thromboembolism. If a subject tests positive in the Bethesda assay (with Nijmegen modification) during Years 3-5, a fresh sample should be collected within 4 weeks of the initial visit that had a positive result.

<sup>d</sup> Sample testing during Long-Term Follow-Up is not required if at least 3 consecutive samples were negative during the Post-Infusion Follow-Up period. Subjects who have not had 3 consecutive negative semen samples by Week 52 should continue to have PCR testing of semen every 4 weeks (during Year 2) or every 6 weeks (during Years 3-5) until 3 consecutive negative samples are documented (or upon consultation between the Investigator and Medical Monitor).

<sup>e</sup> Blood samples will be collected to evaluate biochemical, molecular, cellular, and genetic/genomic aspects relevant to hemophilia A, coagulation, and/or AAV gene transfer, and to develop assays used for these evaluations. Subjects may choose to opt out of the exploratory genetic/genomic research being done to study or try to discover genes that are not yet known to be



---

associated with hemophilia A. While exploratory samples will be collected at the time points indicated above, testing of these samples (including those for TGA assay, Direct Thrombin Activity test, and any other exploratory assessments) will be performed only as deemed necessary by the Sponsor.

<sup>f</sup> PRO assessments during Years 2-5 of Long-Term Follow-up should be performed at the second Q12W visit each year and at every End of Year visit.

<sup>g</sup> Subjects who meet the definition of treatment failure to BMN 270 therapy after Week 52 may omit the Q4W and Q6W visits during Years 2-5, and must attend only the Q12W and End of Year visits. Such subjects following the abbreviated schedule who have not yet cleared vector shedding in all fluids must still provide samples Q4W (during Year 2) or Q6W (during Years 3-5) until vector shedding has been cleared, either by reporting to the site to provide samples or by providing those samples to a MN professional.

**Table 9.1.6: Schedule of Events – Therapeutic Corticosteroids for ALT Elevations**

|   | Steroid Treatment Period <sup>b</sup> |        |        |        |        |        |        |                     | Post-Steroid Period <sup>c</sup> |        |        |        |         |
|---|---------------------------------------|--------|--------|--------|--------|--------|--------|---------------------|----------------------------------|--------|--------|--------|---------|
|   | Week 1                                | Week 2 | Week 3 | Week 4 | Week 5 | Week 6 | Week 7 | Week 8 <sup>b</sup> | Week 1                           | Week 2 | Week 3 | Week 4 | Week 13 |
| Therapeutic corticosteroids (dose in mg/day) <sup>a</sup> | 60 mg                                 | 60 mg  | 40 mg  | 40 mg  | 40 mg  | 30 mg  | 20 mg  | 10 mg               |                                  |        |        |        |         |
| FVIII activity testing                                    |                                       |        |        |        |        |        |        |                     | X                                | X      | X      | X      |         |
| Liver tests   |                                       |        |        |        |        |        |        |                     | X                                | X      | X      | X      |         |
| Hepatitis B testing <sup>d</sup>                          |                                       |        |        |        |        | X      |        |                     | X                                |        |        |        | X       |
| HCV Viral Load <sup>d</sup>                               |                                       |        |        |        |        | X      |        |                     | X                                |        |        |        | X       |

<sup>a</sup> Therapeutic oral corticosteroids may be initiated according to the parameters set out in Section 9.4.8.2.

<sup>b</sup> Following initiation or completion of steroid regimen, if a recurrence of ALT values  $\geq 1.5x$  ULN or  $> ULN$  &  $> 2x$  baseline value is reported, steroid management decisions will be based on discussions between the Investigator and Medical Monitor. Modification of the steroid regimen may take into consideration possible confounders for the ALT elevation, relationship between increases in ALT and FVIII activity, ALT/FVIII levels post steroid initiation, and adverse events related to steroid dosing. Guidance for tapering oral corticosteroid dosing can be found in Section 9.4.8.2.

<sup>c</sup> After discontinuation of oral corticosteroids, weekly labs for ALT and FVIII levels will be measured once a week for 4 weeks to ensure stability in values. If these assessments are already being done as part of normal study follow-up, they do not need to be duplicated.

<sup>d</sup> Should only be performed in subjects with a history of hepatitis B or hepatitis C prior to study entry.



## 9.2 Discussion of Study Design, Including Choice of Control Group

Study 270-301 is designed to be a Phase 3, single-arm, open-label study in hemophilia A patients with residual FVIII levels  $\leq 1$  IU/dL previously treated with prophylactic exogenous FVIII. Hemophilia A patients who provide written informed consent, meet the entry criteria definition of residual FVIII activity, have well-documented historical data for the previous 12 months concerning exogenous FVIII usage and bleeding episodes, and do not have antibodies to AAV5 will be eligible to enroll in the study.

Approximately 130 subjects will be enrolled at the 6E13 vg/kg BMN 270 dose. Subjects will be followed for 52 weeks post-BMN 270 infusion during which safety and efficacy assessments will be taken. After the final analysis at 52 weeks post-infusion, safety and efficacy will then continue to be assessed long-term for approximately a total of 5 years. During enrollment, the DMC will review available safety and efficacy data on an ongoing basis and may decide to recommend dosing subjects at a different dose level (not to exceed 6E13 vg/kg) based on emerging data from 270-301 and their overall benefit:risk assessment.

Study 270-301 is a self-controlled study. Parameters for each subject will be compared to a pre-treatment assessment of safety (liver function) and efficacy (number of bleeds, use of FVIII replacement therapy).

## 9.3 Selection of Study Population

Approximately 130 adult hemophilia A patients with residual FVIII levels  $\leq 1$  IU/dL may enroll into the study.

Additional criteria for participation in the study are provided in Section 9.3.1 and Section 9.3.2.

### 9.3.1 Inclusion Criteria

Individuals eligible to participate in this study must meet all of the following inclusion criteria:

1. Males  $\geq 18$  years of age with hemophilia A and residual FVIII levels  $\leq 1$  IU/dL as evidenced by medical history, at the time of signing the informed consent.
2. Must have been on prophylactic FVIII replacement therapy for at least 12 months prior to study entry. High-quality, well-documented historical data concerning bleeding episodes and FVIII usage over the previous 12 months must be available.
3. Treated/exposed to FVIII concentrates or cryoprecipitate for a minimum of 150 exposure days (EDs).





4. Willing and able to provide written, signed informed consent after the nature of the study has been explained and prior to any study-related procedures.
5. No previous documented history of a detectable FVIII inhibitor, and results from a Bethesda assay or Bethesda assay with Nijmegen modification of less than 0.6 Bethesda Units (BU) (or less than 1.0 BU for laboratories with a historical lower sensitivity cutoff for inhibitor detection of 1.0 BU) on 2 consecutive occasions at least one week apart within the past 12 months (at least one of which should be tested at the central laboratory).
6. Sexually active participants must agree to use an acceptable method of effective contraception, either double-barrier contraception (ie, condom + diaphragm; or condom or diaphragm + spermicidal gel or foam) or their female partner either using hormonal contraceptives or having an intrauterine device. Participants must agree to contraception use for at least 12 weeks post-infusion; after 12 weeks, subjects may stop contraception use only if they have had 3 consecutive semen samples with no detectable viral vector DNA.
7. Willing to abstain from alcohol consumption for at least the first 52 weeks following BMN 270 infusion.

### 9.3.2 Exclusion Criteria

Individuals who meet any of the following exclusion criteria will not be eligible to participate in the study:

1. Detectable pre-existing antibodies to the AAV5 capsid.
2. Any evidence of active infection or any immunosuppressive disorder, including HIV infection.
3. Significant liver dysfunction with any of the following abnormal laboratory results:
  - ALT (alanine aminotransferase) > 1.25x ULN;
  - AST (aspartate aminotransferase) > 1.25x ULN;
  - GGT (gamma-glutamyltransferase) > 1.25x ULN;
  - Total bilirubin > 1.25x ULN;
  - Alkaline phosphatase > 1.25x ULN; or
  - INR (international normalized ratio)  $\geq$  1.4.

Subjects whose liver laboratory assessments fall outside of these ranges may undergo repeat testing of the entire liver test panel within the same Screening window and, if eligibility criteria are met on retest, may be enrolled after confirmation by the Medical Monitor.



4. Prior liver biopsy showing significant fibrosis of 3 or 4 as rated on a scale of 0-4 on the Batts-Ludwig (Batts, 1995) or METAVIR (Bedossa, 1996) scoring systems, or an equivalent grade of fibrosis if an alternative scale is used.
5. Evidence of any bleeding disorder not related to hemophilia A.
6. Platelet count of  $< 100 \times 10^9/L$ .
7. Creatinine  $\geq 1.5$  mg/dL.
8. Liver cirrhosis of any etiology as assessed by liver ultrasound.
9. Chronic or active hepatitis B as evidenced by positive serology testing (HBsAg, HBsAb, and HBcAb) and confirmatory HBV DNA testing. Refer to the Centers for Disease Control (CDC) table for the interpretation of serological test results in the Laboratory Manual.
10. Active Hepatitis C as evidenced by detectable HCV RNA or currently on antiviral therapy.
11. Active malignancy, except non-melanoma skin cancer.
12. History of hepatic malignancy.
13. History of arterial or venous thromboembolic events (eg, deep vein thrombosis, non-hemorrhagic stroke, pulmonary embolism, myocardial infarction, arterial embolus), with the exception of catheter-associated thrombosis for which anti-thrombotic treatment is not currently ongoing.
14. Known inherited or acquired thrombophilia, including conditions associated with increased thromboembolic risk, such as atrial fibrillation.
15. Treatment with any investigational product within 30 days or 5 half-lives of the investigational product prior to the screening period. For subjects who have received a prior investigational product, all ongoing adverse events (AEs) experienced while receiving that investigational product must have resolved prior to screening for this study.
16. Any condition that, in the opinion of the Investigator or Sponsor would prevent the patient from fully complying with the requirements of the study (including possible corticosteroid treatment outlined in the protocol) and/or would impact or interfere with evaluation and interpretation of subject safety or efficacy result.
17. Prior treatment with any vector or gene transfer agent.
18. Major surgery planned in the 52-week period following the infusion with BMN 270.
19. Use of systemic immunosuppressive agents, not including corticosteroids, or live vaccines within 30 days before the BMN 270 infusion.



20. Concurrent enrollment in another clinical study, unless it is an observational (non-interventional) clinical study that does not interfere with the requirements of the current protocol or have the potential to impact the evaluation of efficacy and safety of BMN 270 and with prior consultation with the Medical Monitor.
21. Known allergy or hypersensitivity to BMN 270 investigational product formulation.
22. Unwilling to receive blood or blood products for treatment of an adverse event and/or a bleeding episode.

### **9.3.3 Removal of Subjects from Treatment or Assessment**

Subjects may withdraw their consent to participate in the study at any time without prejudice. The Investigator must withdraw from the study any subject who requests to be withdrawn. Such subjects will always be asked about the reason(s) for withdrawal. The Investigator will discuss with the subject appropriate procedures for withdrawal from the study. The Investigator should ask the subject's consent to perform the procedures listed under the early termination visit. Should a subject withdraw from the study, all efforts will be made to complete and report the observations as thoroughly as possible up to the date of the withdrawal.

A subject's participation in the study may be discontinued at any time at the discretion of BioMarin or of the Investigator and in accordance with his/her clinical judgment. When possible, the tests and evaluations listed for the termination visit should be carried out and every effort will be made to gather follow-up safety data if possible.

BioMarin must be notified of all subject withdrawals as soon as possible. BioMarin also reserves the right to discontinue the study at any time for either clinical or administrative reasons and to discontinue participation by an individual Investigator or site for poor enrollment or noncompliance.

Reasons for which the Investigator or BioMarin may withdraw a subject from the study include, but are not limited to, the following:

- Subject requires medication or medical procedure prohibited by the protocol
- Subject does not adhere to study requirements specified in the protocol
- Subject was erroneously enrolled into the study or does not meet entry criteria and not yet been dosed with BMN 270; subjects who do not meet entry criteria but who erroneously receive BMN 270 should remain in the study for safety monitoring
- Subject is lost to follow-up

If a subject fails to return for scheduled visits, a documented effort must be made to determine the reason. If the subject cannot be reached by telephone, a certified letter should



be sent to the subject requesting contact with the Investigator. This information should be recorded in the study records.

The Investigator or designee must explain to each subject, before enrollment into the study, that for evaluation of study results, the subject's protected health information obtained during the study may be shared with the study Sponsor, regulatory agencies, and IRB/IEC/REB. It is the Investigator's (or designee's) responsibility to obtain written permission to use protected health information per country-specific regulations, such as the Health Insurance Portability and Accountability Act (HIPAA) in the US, from each subject. If permission to use protected health information is withdrawn, it is the Investigator's responsibility to obtain a written request, to ensure that no further data will be collected from the subject and the subject will be removed from the study.

#### 9.3.3.1 Study Safety Evaluation Criteria

If any of the following events occur in a subject in the study who has received BMN 270 infusion, an urgent evaluation by the DMC will be required and further enrollment into the trial will be temporarily put on hold if recommended by the DMC per Section 9.1.

1. Liver dysfunction (criteria do not apply to ALT elevations with an extra-hepatic etiology):
  - ALT > 5x ULN, for more than 2 weeks
  - ALT > 3x ULN **and** (total bilirubin > 2x ULN **or** INR >1.5)
  - ALT > 3x ULN with signs and symptoms of liver dysfunction
2. The occurrence of Grade 4 or Grade 5 adverse events assessed as related to study drug (events of liver dysfunction are defined above).
3. The occurrence of an AE of hepatic failure.
4. The detection of high-titer neutralizing antibodies (>5 BU) to hFVIII following BMN 270 infusion in two subjects.
5. The occurrence of any cancer (except non-melanoma skin cancer) at any point after BMN 270 infusion.
6. The occurrence of a thromboembolic event with FVIII activity > 150 IU/dL in one subject.

If any of the following events occurs in a subject in the study who has received BMN 270 infusion, an urgent evaluation by the DMC will be required. Further enrollment into the trial will continue while DMC evaluation is ongoing, unless deemed otherwise by the DMC:

1. The detection of high-titer neutralizing antibodies (>5 BU) to hFVIII following BMN 270 infusion in one subject.



2. Occurrence of a thromboembolic event in one subject.

### **9.3.4 Subject Identification and Replacement of Subjects**

Each subject will be assigned a unique subject identifier. This unique identifier will be on all eCRF pages. In legal jurisdictions where use of initials is not permitted, a substitute identifier will be used.

Subjects who withdraw from the study after receiving BMN 270 will not be replaced.

### **9.3.5 Duration of Subject Participation**

The duration of participation for each subject will be approximately 264 weeks. This includes 4 weeks of screening, 1 day of BMN 270 infusion, 52 weeks of Post-Infusion Follow-Up, and 208 weeks of Long-Term Follow-Up.

## **9.4 Treatments**

### **9.4.1 Treatments Administered**

BioMarin and/or its designee will provide the study site with a supply of IP sufficient for the completion of the study. BioMarin is responsible for shipping study drug to clinical sites.

### **9.4.2 Identity of Investigational Product**

#### **9.4.2.1 Product Characteristics and Labeling**

BMN 270 is a sterile, clear, colorless-to-pale yellow solution for IV infusion and is supplied in a 10 mL Crystal Zenith® (CZ) vial. Each vial contains 8.5 mL (extractable volume 8 mL) of AAV5-hFVIII-SQ at a concentration of 2E13 vector genomes per mL in a pH 7.4 phosphate buffer.

The study drug is labelled according to the particulars approved by the relevant regulatory agencies.

#### **9.4.3 Storage**

At the study site, all IP must be stored under the conditions specified in the Pharmacy Manual in a secure area accessible only to the designated pharmacists and clinical site personnel. All IP must be stored and inventoried and the inventories must be carefully and accurately documented according to applicable state, federal and local regulations, ICH GCP, and study procedures.



#### 9.4.4 Directions for Administration

On the day of infusion, the subject will come to the infusion site, where a physical examination will be performed by the Investigator or designee. If the subject is found to have an active acute illness at the time of planned infusion, then the infusion should be deferred until the illness has resolved; screening procedures may require repetition if outside the specified window. An IV catheter or butterfly needle will be inserted into a suitable peripheral vein (eg, the median cubital vein) and flushed with saline. FVIII replacement therapy will not be given since venipuncture is a minimally invasive procedure in these individuals under ordinary conditions.

BMN 270 will be prepared and infused as a pure solution over a dose-dependent time. Prepared drug will be kept at room temperature prior to administration. An electric syringe pump will be used to infuse through an in-line, low protein binding 0.22 micron filter. BMN 270 will be infused through the catheter using an appropriate infusion pump at an initial rate of 1 mL/min. The infusion rate should be increased every 30 minutes by 1 mL/min up to a maximum of 4 mL/min, provided that the subject's clinical condition permits such an increase. Of note, the IP has been shown to be stable at room temperature for 7.5 hours following completion of product thaw. Vital signs (pulse, blood pressure, respiration rate and temperature) should be monitored at 15 minute ( $\pm 5$  minutes) intervals throughout the time period of the infusion.

As with any infused biological product, there is a potential risk of acute, systemic hypersensitivity reactions (including anaphylaxis) with BMN 270. Dosing will be administered at a qualified infusion site, with appropriate resuscitation equipment and medication available and easily accessible.

Clinical staff administering BMN 270 should be trained appropriately in recognizing and managing the signs and symptoms associated with potential hypersensitivity, anaphylactic, and anaphylactoid reactions. Additionally, the Investigator should be familiar with Sampson's criteria for defining anaphylaxis (Sampson, 2006; Appendix 1).

Should symptoms of potential hypersensitivity occur, the infusion may be slowed or halted at the Investigator's discretion, with consideration of the subject's clinical condition. If the infusion is halted, it should only be restarted if the Investigator considers it safe and appropriate to do so. Antihistamines, anti-pyretic, and/or corticosteroid administration is permitted prior to restarting an interrupted infusion by an infusion-related reaction. At the restart, the infusion rate may be adjusted (ie, to a slower rate [minimum of 1 mL/min], with



the rate increased every 30 minutes by 1 mL/min up to a maximum rate of 4 mL/min, if the subject's clinical condition permits such an increase) with careful monitoring of the subject.

In case of hypersensitivity or adverse drug reaction, safety assessment, including physical examination and vital signs, will be done and additional blood samples will be collected within 1 hour of the hypersensitivity reaction (eg, tryptase, C3, C3a, C4, C5, C5a, and cytokine bead array, as well as possible additional exploratory testing) and samples for IgE and cytokine bead array (and possible additional exploratory testing) between 8-24 hours after the reaction, if possible. In addition, a blood sample should be taken 1 week after the hypersensitivity reaction for assessment of the cytokine bead array. In-patient observation can be extended and additional blood samples can be collected if deemed necessary at the discretion of the Investigator and Medical Monitor.

Following completion of the infusion, vital signs will be monitored hourly ( $\pm$  5 minutes). If the vital signs are stable the catheter will be removed 8 hours after the infusion. Hemostasis at the puncture site will be established by applying pressure according to standard protocol for infusing FVIII concentrates. Subjects will remain in the clinic for at least 8 hours to observe for any immediate toxicity of the procedure; in-patient observation can be extended beyond 8 hours if needed per Investigator discretion, or the subject may transfer to a separate facility based on the evaluation and judgment of the Principal Investigator after consultation with the Medical Monitor.

Prior to discharging subjects from the clinic, the Investigator or designee should instruct subjects how to recognize signs and symptoms of potential (delayed) hypersensitivity reactions and anaphylaxis, and to contact a medical practitioner or seek emergency care in case of such an event.

#### **9.4.5 Method of Assigning Subjects to Treatment Groups**

Subjects who meet all eligibility criteria (refer to Section 9.3.1 and Section 9.3.2) may be enrolled into the study. Approval by the Medical Monitor will be required prior to enrollment of each study subject. Upon their enrollment into the study, subjects will be assigned a unique subject number.

Approximately 130 subjects will be enrolled at 6E13 vg/kg.

#### **9.4.6 Selection of Dose Used in the Study**

Data from an ongoing first in human study (Clinical Study 270-201) indicates that following single escalated doses of BMN 270 (6E12, 2E13, 4E13, 6E13 vg/kg), dose-related increases in FVIII activity were observed, with concurrent improvements in bleeding episodes and





exogenous FVIII utilization, particularly at the 4E13 and 6E13 vg/kg dose levels. At all dose levels, BMN 270 is considered to be well-tolerated with mild increases in ALT as the most common adverse event. Please refer to the IB for detailed efficacy and safety data.

In order to further evaluate the dose-response relationship of BMN 270, subjects will be enrolled at a dose of 6E13 vg/kg. This dose is expected to be safe and effective based on clinical experience to date in 270-201. The DMC will review emerging safety and efficacy data and may recommend that a different dose (not to exceed 6E13 vg/kg) be administered. In such a case, up to 130 additional subjects may be enrolled at the new dose.

#### **9.4.7 Blinding**

This is an open-label study.

#### **9.4.8 Prior and Concomitant Medications**

All prescription and over-the-counter medications (including dietary and herbal supplements) taken by a subject for 30 days before Screening will be recorded on the designated eCRF. The Investigator may prescribe additional medications, deemed necessary to provide adequate prophylactic or supportive care, during the study, as long as the prescribed medication is not prohibited by the protocol. In the event of an emergency, any needed medications may be prescribed without prior approval, but the Medical Monitor must be notified of the use of any contraindicated medications immediately thereafter. Any concomitant medications added or discontinued during the study should be recorded on the eCRF. Medications should, whenever possible, not be recorded in the electronic database with a frequency of PRN.

The following medications are prohibited starting 30 days before Screening and through the end of the study, and the Sponsor must be notified if a subject receives any of these during the study:

- Any investigational therapy
- Systemic immunosuppressive agents, except for corticosteroids
- Emicizumab
- Fitusiran
- Concizumab
- Efavirenz
- Lamivudine





The following medications should be avoided, starting 30 days prior to and for at least 52 weeks after BMN 270 infusion and minimized throughout the remaining duration of the study.

- Alcohol
- Herbal and natural remedies and dietary supplements
- Medications which may be hepatotoxic

Vaccines should also be avoided during this period, but in particular during the first 26 weeks unless clinically indicated.

The following medications should be avoided during oral corticosteroid therapy:

- Vaccines
- NSAIDs

#### **9.4.8.1 Concomitant Hemophilia Treatments**

Subjects on prophylactic FVIII therapy will discontinue their regular treatment regimen starting 4 weeks after the day of infusion and switch to an “on-demand” schedule. FVIII replacement therapy can always be taken as needed by the subject for treatment of an acute bleeding episode; the subject must carefully record his treatment and bleeding episodes in his diary. Prophylactic FVIII use can be used on a case-by-case basis and in consultation with the Medical Monitor to prevent bleeding in extenuating circumstances (eg, peri-operative).

In addition, information on FVIII usage and bleeding episodes by medical history must be well-documented and available and will be collected from subjects for the 12-month period immediately preceding study enrollment. Further information on the details that should be provided as part of the subject’s well-documented medical and FVIII usage history are provided in the On Site File Binder.

In order to enable rigorous comparisons of pre-study versus on-study FVIII usage and bleeding episodes, the Medical Monitor will review each screened patient’s prior bleed and hemophilia medication logs to determine if they are of “high-quality”. Elements that will be assessed to judge the quality of such historical data may include, but are not limited to, the following:

- Date, type (eg, joint, muscle, other), location of bleeds
- Date, name, dose (calculated in IU/kg), and reason for use (eg, usual prophylaxis, one-time prophylaxis, treatment for bleed, surgery) of hemophilia medications.

### 9.4.8.2 Therapeutic Glucocorticoid Treatment of Elevated Hepatic Transaminases

Therapeutic oral corticosteroids (prednisone or converted equivalent) should be initiated when either of the following occurs post-BMN 270 infusion in any subject and after consultation with the Medical Monitor (or their designee):

- ALT  $\geq 1.5x$  ULN or ALT  $> ULN$  &  $> 2x$  baseline value in 2 consecutive assessments within 72 hours and alternative etiologies have been ruled out, or ALT  $\geq 3x$  ULN in 2 consecutive assessments within 48 hours (refer to [Table 9.8.8.3.2](#))
  - Whenever possible, a confirmatory lab draw for ALT should be performed, along with FVIII activity, prior to initiating oral corticosteroids.
  - Corticosteroids may be delayed if elevations in ALT are clearly not related to BMN 270 (eg, elevated ALT with concurrent increase in CPK due to intensive exercise)

The prescribed regimen for therapeutic oral corticosteroids is detailed in [Table 9.1.6](#).

Changes to the corticosteroid regimen should be made as follows:

**Table 9.4.8.2.1: Adjustments to Corticosteroid Regimen**

|   |   |   |
|---|---|---|
| <b>Tapering<br/>Corticosteroid<br/>Dose</b>   | Subject has been receiving oral corticosteroids <3 weeks  | Corticosteroids may be discontinued <b>if</b> : <ul style="list-style-type: none"> <li>• ALT <math>&lt; 1.5x</math> ULN or ALT <math>\leq ULN</math> &amp; <math>\leq 2x</math> baseline value; and</li> <li>• FVIII levels <math>&gt; 20</math> IU/dL and within 10% of the pre-decline FVIII levels; and</li> <li>• There is no concern for adrenal insufficiency post-withdrawal</li> </ul>            |
|   | Subject has been receiving oral corticosteroids $\geq 3$ weeks  | Corticosteroids may be tapered by 10 mg weekly <b>if</b> : <ul style="list-style-type: none"> <li>• ALT <math>&lt; 1.5x</math> ULN or ALT <math>\leq ULN</math> &amp; <math>\leq 2x</math> baseline value; and</li> <li>• FVIII levels <math>&gt; 20</math> IU/dL and within 10% of the pre-decline FVIII levels; and</li> <li>• There is no concern for adrenal insufficiency post-withdrawal</li> </ul> |
| <b>Increasing<br/>Corticosteroid<br/>Dose</b> | If ALT level is increasing or FVIII level is decreasing while on oral corticosteroids, any increases in oral corticosteroid dosing should be made only upon consultation with the Medical Monitor |   |

For any scenarios that are not accounted for in the above table, a discussion should take place between the Investigator and Medical Monitor regarding corticosteroid dose adjustments.

After discontinuation of oral corticosteroids, labs for ALT and FVIII levels will be measured once a week for 4 weeks to ensure stability in values.

Following initiation or completion of therapeutic oral corticosteroids, if ALT elevation  $\geq 1.5x$  ULN or ALT  $\geq ULN$  &  $\geq 2x$  baseline value is reported, corticosteroid management decisions will be based on discussions between the Investigator and Medical Monitor.



Modification of the corticosteroid regimen may take into consideration possible confounders for the ALT elevation and impact on FVIII expression.

Management and monitoring of reactions to corticosteroids should be determined by the Investigator's clinical judgment in consultation with the Sponsor's Medical Monitor. This includes the contraindicated use of NSAIDs during corticosteroid treatment and specific monitoring not already covered by the schedule of events. The use of COX-2 inhibitors, while not contraindicated during corticosteroid treatment, should be limited, if possible. Practical management to prevent complications related to oral corticosteroid therapy may be undertaken at the discretion of the Investigator (eg, evaluation of glucose intolerance, hyperlipidemia etc.). Hepatitis B status and HCV viral load will be rechecked 6 weeks after the start of oral corticosteroid treatment and then 1 week and 13 weeks after the completion of oral corticosteroid treatment in subjects with a history of hepatitis B or hepatitis C. All adverse events (including any adverse events suspected to be caused by or related to corticosteroid use) should be reported as outlined in Section 10 of the protocol.

#### **9.4.8.3 Monitoring of HIV-Positive Subjects**

HIV-positive subjects who have previously enrolled in 270-301 should continue anti-retroviral therapy (ART) as prescribed and follow routine monitoring of CD4 count and viral load ([US Dept Health Human Services, 2014](#)). No alterations in the monitoring are indicated for enrolled immunocompetent HIV-positive subjects who receive corticosteroids as part of their enrollment in 270-301.

### **9.5 Treatment Compliance**

Study drug will be administered to subjects at the study site and/or the dosing facility by a qualified health care professional. The quantity dispensed, returned, used, lost, etc. must be recorded on a dispensing log. Sites will be instructed to return or destroy all used and unused study drug containers.

### **9.6 Investigational Product Accountability**

The Investigator or designee is responsible for maintaining accurate records (including dates and quantities) of IP(s) received and IP lost or accidentally or deliberately destroyed. The Investigator or designee must retain all unused or expired study supplies until the study monitor (on-site CRA) has confirmed the accountability data, if allowed by local SOPs.

#### **9.6.1 Return and Disposition of Clinical Supplies**

Unused study drug must be kept in a secure location for accountability and reconciliation by the study monitor. The Investigator or designee must provide an explanation for any



destroyed or missing study drug or study materials (or must be referenced in their institution SOPs).

Unused study drug may be destroyed on site, per the site's standard operating procedures, but only after BioMarin has granted approval for drug destruction. The monitor must account for all study drug in a formal reconciliation process prior to study drug destruction. All study drug destroyed on site must be documented. Documentation must be provided to BioMarin or designee and retained in the Investigator study files. If a site is unable to destroy study drug appropriately, the site can return unused study drug to BioMarin upon request. The return of study drug or study drug materials must be accounted for on a study drug return form provided by BioMarin.

All study drug and related materials should be stored, inventoried, reconciled, and destroyed or returned according to applicable state and federal regulations and study procedures. For additional information, please refer to the Pharmacy Manual.

## **9.7 Dietary or Other Protocol Restrictions**

There are no dietary or other protocol restrictions for this study. Alcohol should be avoided for the first 52 weeks of the study, and particularly within 48 hours prior to lab work.

Subjects should be advised to abstain from any blood or sperm donation after BMN 270 infusion, until there is no further evidence of vector shedding from PCR analysis of samples.

## **9.8 Safety and Efficacy Variables**

### **9.8.1 Safety and Efficacy Measurements Assessed**

The Schedule of Events ([Table 9.1.1](#) through [Table 9.1.5](#)) describes the timing of required evaluations.

### **9.8.2 Primary Efficacy Variables**

#### **9.8.2.1 FVIII Activity**

The primary efficacy variable is change of the hFVIII activity, as measured by chromogenic substrate assay, during Weeks 49-52 post-BMN 270 infusion from baseline. Each subject's hFVIII activity during Weeks 49-52 is defined as the median of the values obtained during this 4-week window. Values for FVIII activity will be excluded if obtained within 72 hours since the last infusion of exogenous FVIII protein concentrates.

If a subject has used FVIII within 72 hours of a measurement day, all efforts should be made to obtain FVIII activity measurements when a 72-hour interval without FVIII use is achieved; The 72-hour wash-out period is only intended for subjects who have achieved



FVIII  $\geq$  5 IU/dL at 16 weeks after BMN 270 infusion and who have not resumed FVIII replacement therapy.

In the event of an FVIII activity level decline during the study:

- If FVIII activity has declined at least 20% from the peak but less than 35% and has declined for at least 2 consecutive assessments, FVIII activity and LTs should be repeated every 7 days until FVIII activity is stable or increasing
- If FVIII activity has declined  $>35\%$  from the peak and has declined for at least 2 consecutive assessments, FVIII activity and LTs should be repeated every 72 hours until FVIII activity is stable or increasing

Note that fluctuations in FVIII activity are common, and if no clear trend indicating a decline in FVIII activity is observed, then this additional testing may be deferred (upon consultation between the Investigator and the Medical Monitor) until either a more clear trend of decline has been demonstrated or until the FVIII activity levels stabilize or increase.

Subjects who do not respond to BMN 270 treatment (ie treatment failure, manifesting as either failure to achieve FVIII activity  $\geq$  5 IU/dL by Week 52 or inability to maintain independence from prophylactic FVIII replacement therapy due to joint bleeding episodes, in the judgment of the Investigator) may, at the Investigator's discretion and after discussion with the Medical Monitor, follow an abbreviated visit schedule after Week 52 of the study by attending only the Q12W and End of Year visits during Years 2-5.

Details on collecting FVIII activity samples are included in the Laboratory Manual.

### **9.8.3 Secondary Efficacy Variables**

#### **9.8.3.1 Factor VIII Replacement Therapy/Bleeding Episodes**

Secondary efficacy variables are:

- Change of the annualized utilization (IU/kg) of exogenous FVIII replacement therapy during Week 5 to Week 52 post BMN 270 infusion from the baseline utilization of exogenous FVIII replacement therapy.
- Change in the annualized number of bleeding episodes requiring exogenous FVIII replacement treatment during Week 5 to Week 52 of the study post BMN 270 infusion from the baseline ABR.

Subjects must have high quality documented historical data available concerning previous bleeding episodes and exogenous FVIII usage over the previous 12 months in order to be eligible to enroll in the study. During the study, subjects will be asked at each study visit to report the use of factor replacement therapy and the number of bleeding episodes since the



previous visit. This information will be captured on the subject's diary or other subject records.

Subjects are strongly encouraged to immediately consult Investigator for guidance regarding exogenous FVIII administration for suspected bleeds or bleeding episodes within the first 30 days post BMN 270 infusion.

In subjects who experience recurrent bleeding episodes, the Investigator and Medical Monitor will discuss whether to resume prior FVIII prophylaxis.

#### **9.8.4 Tertiary Efficacy Variables**

##### **9.8.4.1 Patient-Reported Outcomes (PRO)**

The Haemo-QoL-A questionnaire is a validated hemophilia-specific health-related quality of life questionnaire for adults ([Rentz, 2008](#)). It consists of 41 questions covering six domains (Physical Functioning, Role Functioning, Worry, Consequences of Bleeding, Emotional Impact and Treatment Concerns). Items are answered on a 6-point Likert-type scale, ranging from 0 (None of the time) to 5 (All of the time). Higher scores mean better health-related quality of life or less impairment for a particular subscale ([Haemo-QoL Study Group, 2017](#)). Details regarding the Haemo-QoL-A assessment will be included in the On Site File Binder.

The EQ-5D-5L instrument is a self-reported questionnaire designed to measure general health status ([The EuroQol Group, 1990](#)) ([Brooks, 1996](#)). The EQ-5D-5L is composed of 2-parts: a descriptive system that assesses 5 levels of perceived problems (mobility, self-care, usual activities, pain/discomfort, and anxiety/depression) in 5 dimensions and the EQ visual analogue scale (EQ VAS) assessment for overall health. A sample copy of the EQ-5D-5L and additional information are provided in the On Site File Binder.

The Haemophilia Activities List (HAL) measures the impact of hemophilia on self-perceived functional abilities in adults ([Van Genderen, 2006](#)). The instrument consists of multiple domains including lying/sitting/kneeling/standing, leg and arm function, use of transportation, self-care, household tasks, and leisure activities where subjects are asked to rate their level of difficulty with activities of daily living on a 6-point Likert-type scale from 1 (Impossible) to 6 (Never). For some items, subjects are given the choice to answer 'Not applicable'. A sample copy of the HAL and additional information are provided in the On Site File Binder.

The Work Productivity and Activity Impairment plus Classroom Impairment Questions: Hemophilia Specific (WPAI+CIQ:HS) instrument is designed to measure the effect of disease symptom severity on work productivity and classroom productivity (if applicable)





(Recht, 2014). The WPAI+CIQ:HS questionnaire yields scores related to work/classroom absenteeism, reduced on-the-job effectiveness, overall work/classroom impairment, and activity impairment. WPAI+CIQ:HS outcomes are expressed as impairment percentages, with higher numbers indicating greater impairment and less productivity (Reilly, 2002). A sample copy of the WPAI+CIQ:HS and additional information are provided in the On Site File Binder.

The Patient Reported Outcomes, Burdens, and Experiences (PROBE) questionnaire is designed to investigate and directly probe patient perspectives on outcomes they deem relevant to their life and care. PROBE aims to develop a new global tool to enhance the direct patient-voice in health care decision-making (Chai-Adisaksopha, 2017). A sample copy of the PROBE questionnaire and additional information are provided in the On Site File Binder.

### **9.8.5 Immunogenicity**

Immunogenicity assays will be performed on plasma and PBMCs. The assays will include detection of anti-AAV5 capsid and anti-FVIII total antibodies, as well as determination of neutralizing antibodies against FVIII (FVIII inhibitors) and against the AAV5 capsid (Transduction Inhibitors, TI). FVIII Inhibitors will be assessed using the Bethesda assay with Nijmegen modification. Any abnormality of the liver parameters will lead to a retrospective immunogenicity assessment to evaluate FVIII- and capsid-specific cellular immunogenicity. FVIII- and capsid-specific cellular immunity will be assessed by stimulated cytokine secretion using an ELISpot assay performed on collected PBMCs.

### **9.8.6 Pharmacodynamics**

The FVIII protein concentration and activity level as measured by a validated immunoassay and by a validated FVIII activity assay, respectively, will be used for plasma profiles; FVIII protein and activity will be used to determine PD parameters.

### **9.8.7 Exploratory Assessments**

Blood samples will be collected from subjects at the time points indicated in [Table 9.1.1](#), [Table 9.1.2](#), [Table 9.1.3](#), [Table 9.1.4](#), and [Table 9.1.5](#) to evaluate biochemical, molecular, cellular, ABO blood typing, and genetic/genomic aspects relevant to hemophilia A, coagulation, and/or AAV gene transfer, and to develop assays used for these evaluations. Subjects may choose to opt out of the exploratory genetic/genomic research being done to study or try to discover genes that are not yet known to be associated with hemophilia A.



All biomarker samples collected in this study may be used for exploratory biomarker research, including evaluation of additional biomarkers not specifically listed in the protocol. In addition, samples collected for other purposes in this study may be used for exploratory research once testing for the primary purpose has been completed.

### **9.8.8 Safety Variables**

Safety in this study will be determined from evaluation of AEs, clinical laboratory assessments with a particular attention to the liver function, vital signs assessments, physical examinations, and immunogenicity.

#### **9.8.8.1 Adverse Events**

The determination, evaluation and reporting of AEs will be performed as outlined in Section 10.

#### **9.8.8.2 Clinical Laboratory Assessments**

The scheduled clinical laboratory tests are listed in [Table 9.8.8.2.1](#). Refer to the On Site File Binder for instructions on obtaining and shipping samples.

Any abnormal test results determined to be clinically significant by the Investigator should be repeated (at the Investigator's discretion) until: (1) the cause of the abnormality is determined; (2) the value returns to baseline or to within normal limits; or (3) the Investigator determines that the abnormal value is no longer clinically significant.

All abnormal clinical laboratory results should be initialed and dated by an Investigator, along with a comment regarding whether or not the result is clinically significant. Each clinically significant laboratory result should be recorded as an adverse event.

The diagnosis, if known, associated with abnormalities in clinical laboratory tests that are considered clinically significant by the Investigator will be recorded on the AE eCRF.



**Table 9.8.8.2.1: Clinical Laboratory Tests**

| <b>Blood Chemistry</b> | <b>Hematology</b>         | <b>Urine Tests</b> | <b>Coagulation Screen including:</b> |
|------------------------|---------------------------|--------------------|--------------------------------------|
| Albumin                | Hemoglobin                | Appearance         | APTT                                 |
| BUN                    | Hematocrit                | Color              | PT/INR                               |
| Calcium                | WBC count                 | pH                 | TT                                   |
| Chloride               | RBC count                 | Specific gravity   |                                      |
| Total cholesterol      | Platelet count            | Ketones            |                                      |
| CPK                    | Differential cell count   | Protein            |                                      |
| Creatinine             | RBC indices (MCV and MCH) | Glucose            |                                      |
| CRP                    |                           | Bilirubin          |                                      |
| Glucose                |                           | Nitrite            |                                      |
| Phosphorus             |                           | Urobilinogen       |                                      |
| Potassium              |                           | Hemoglobin         |                                      |
| Total protein          |                           |                    |                                      |
| Sodium                 |                           |                    |                                      |
| Uric Acid              |                           |                    |                                      |

BUN, blood urea nitrogen; CPK, creatinine phosphokinase; CRP, C-reactive protein; PT, prothrombin time; APTT, activated partial thromboplastin time; RBC, red blood cell; WBC, white blood cell; TT, thrombin time; INR, international normalized ratio; MCV, mean corpuscular volume; MCH, mean corpuscular hemoglobin.

In addition to scheduled clinical laboratory assessments, a fasting blood lipid panel (including triglycerides, total cholesterol, HDL cholesterol, and LDL cholesterol) will be assessed at the BMN 270 infusion visit. Subjects will fast for at least 8 hours prior to pre-infusion laboratory sampling on the day of the infusion visit.

In case of hypersensitivity or adverse drug reaction, safety assessment, including physical examination and vital signs, will be done and additional blood samples will be collected within 1 hour of the hypersensitivity reaction (eg, tryptase, C3, C3a, C4, C5, C5a, and cytokine bead array, as well as possible additional exploratory testing) and samples for IgE and cytokine bead array (and possible additional exploratory testing) between 8-24 hours after the reaction. In addition, a blood sample should be taken 1 week after the hypersensitivity reaction for assessment of the cytokine bead array.

During Years 2-5, at applicable sites, certain study assessments may be performed by a mobile nursing (MN) professional at the patient's home or another suitable location, such as their school or office, to improve access and convenience for patients participating in the



study. The Sponsor may select a healthcare company that will be responsible for providing MN services for participating sites (the MN vendor). The MN vendor is responsible for ensuring that all MN professionals are licensed, qualified, and in good standing, as per applicable regulations, and that appropriate background checks have been performed. If the investigator at a participating site determines that MN services are appropriate for a patient and the patient gives written informed consent to participate in MN visits, the MN network will communicate with the patient and the patient's site. MN visits will be allowed for the Q4W (during Year 2) and Q6W (during Years 3-5) visits; the Q12W visits and End of Year visits during Years 2-5 will not be performed by an MN professional but will be done at the study site.

### **9.8.8.3 Liver and Hepatitis Testing**

Subjects will be screened for evidence of previous or active hepatitis B or hepatitis C infection at Screening; hepatitis B screening should include HBsAg, HBsAb, and HBcAb. Subjects with documented results showing an absence of active hepatitis B or hepatitis C infection (as measured by positive surface antigen for hepatitis B or positive RNA testing for hepatitis C) 30 days prior to providing signed informed consent do not need to repeat those tests during the screening period.

Evidence of ongoing hepatitis B or hepatitis C infection is exclusionary. Subjects with a history of hepatitis B or hepatitis C infection prior to study entry will be tested for hepatitis B and hepatitis C reactivation at Week 16. Subjects with a history of hepatitis B or hepatitis C will be asked for information about the treatments received as part of their medical history assessment at Screening.

Subjects with a previous history of hepatitis B or hepatitis C who receive therapeutic oral corticosteroids prior to Week 16 do not need to complete the Week 16 reactivation assessment; instead, they will be tested for hepatitis B and hepatitis C reactivation at the time points listed in [Table 9.1.6](#).

A liver ultrasound and liver tests (LTs) during Screening will identify any significant hepatic dysfunction.

LTs will be monitored on a regular basis; at each time point, the following LTs should be assessed:

**Table 9.8.8.3.1: Liver Tests**

| <b>Liver Tests (LTs)</b> |                  |                 |     |
|--------------------------|------------------|-----------------|-----|
| Alkaline Phosphatase     | AST (SGOT)       | Total Bilirubin | LDH |
| ALT (SGPT)               | Direct Bilirubin | GGT             |     |

ALT, alanine aminotransferase; AST, aspartate aminotransferase; GGT, gamma-glutamyltransferase; LDH, lactate dehydrogenase; SGOT, serum glutamic-oxaloacetic transaminase; SGPT, serum glutamic-pyruvic transaminase

Elevated ALT levels (above the upper limit of normal range) should be evaluated according to the following plan:

**Table 9.8.8.3.2: Evaluation of ALT Elevations**

| ALT Level               | Work-Up   |
|-------------------------|---|
| Above ULN and <1.5x ULN | <ul style="list-style-type: none"> <li>• Continue to monitor LTs and FVIII per protocol (repeat within 7 days if next protocol scheduled visit is &gt;7 days from the time of the reported ALT elevation)</li> <li>• Consider evaluation to rule out alternative etiology (eg, concomitant medications, viral or autoimmune hepatitis, alcohol use, recreational drug use, special diets, strenuous exercise, prior and/or concurrent illnesses, exposure to environmental and/or industrial chemicals, etc.) (refer to <a href="#">Table 9.8.8.3.3</a>)</li> <li>• If ALT is &gt; ULN &amp; &gt; 2x baseline in 2 consecutive assessments within 72 hours and alternative etiologies have been ruled out, start oral corticosteroids upon consultation with the Medical Monitor (refer to <a href="#">Section 9.4.8.2</a>)</li> </ul>  |
| 1.5 - <3x ULN           | <ul style="list-style-type: none"> <li>• Repeat LTs and FVIII within 72 hours</li> <li>• Continue to monitor LTs weekly until ALT is stable or improving</li> <li>• Evaluate and rule out alternative etiologies (as above)</li> <li>• Consult with Medical Monitor</li> <li>• If ALT is <math>\geq 1.5x</math> ULN in 2 consecutive assessments within 72 hours and alternative etiologies have been ruled out, start oral corticosteroids (refer to <a href="#">Section 9.4.8.2</a>)</li> </ul>   |
| $\geq 3x$ ULN           | <ul style="list-style-type: none"> <li>• Consult with Medical Monitor</li> <li>• Evaluate and rule out alternative etiologies (as above)</li> <li>• Repeat LTs and FVIII within 48 hours, and continue with monitoring of LTs at least twice weekly for as long as the subject's ALT remains <math>\geq 3x</math> ULN</li> <li>• If <math>\geq 3x</math> ULN in 2 consecutive assessments within 48 hours, start oral corticosteroids (refer to <a href="#">Section 9.4.8.2</a>)</li> <li>• Obtain other possibly relevant laboratory evaluations (albumin, PT/INR, CRP, etc.)</li> <li>• Obtain complete blood count with differential to assess for eosinophilia</li> <li>• Obtain PBMC to evaluate potential immune response (prior to starting oral corticosteroids)</li> <li>• If no improvement in 14 days, consider gastroenterology and/or hepatology consult, abdominal workup, imaging (including MRI or ultrasound), and/or liver biopsy as appropriate</li> </ul> |



When ruling out alternative viral or autoimmune hepatitis as part of the elevated ALT workup, the following tests should be performed:

**Table 9.8.8.3.3: Viral and Autoimmune Hepatitis Testing**

| <b>Viral Hepatitis Workup Testing</b> | <b>Autoimmune Hepatitis Workup Testing</b> |
|---------------------------------------|--|
| Hepatitis A                           | Smooth muscle antibody                     |
| Hepatitis B                           | Mitochondrial antibody                     |
| Hepatitis C                           | Liver/kidney microsomal antibodies         |
| Hepatitis E                           | Antinuclear antibody (ANA) HEP-2           |
| Cytomegalovirus (CMV)                 |  |
| Epstein-Barr virus (EBV)              |  |
| Herpes simplex virus (HSV) 1 & 2      |  |

#### **9.8.8.4 HIV Testing**

HIV testing will be performed at Screening. Subjects with documented negative results within the last 30 days prior to screening do not need to be retested.

#### **9.8.8.5 Vital Signs, Physical Examinations and Other Observations Related to Safety**

Vital signs will include seated systolic and diastolic blood pressure, heart rate, respiration rate, and temperature. Any clinically significant change in vital signs will be recorded as an AE.

Systolic blood pressure, diastolic blood pressure, heart rate, respiration rate, and temperature will be assessed at Screening, Baseline, and at the beginning of each visit during the Post-Infusion Follow-Up and Long-Term Follow-Up periods. On the day of the BMN 270 Infusion, vital signs will be monitored prior to infusion, during the infusion every 15 minutes ( $\pm 5$  minutes), following the infusion hourly ( $\pm 5$  minutes) for at least 8 hours during the subject's stay in the clinic. Any abnormal vital sign assessments should be repeated, and both values should be recorded in the eCRF.

A complete physical examination is necessary during Screening/Baseline, at Week 26 and 52 and every 52 weeks thereafter; at other visits, brief physical examinations may be performed at the discretion of the Investigator based on the subject's clinical condition. Particular attention should be given to signs of bleeding, as well as assessing possible hemarthroses.



A complete physical examination will include general appearance (head, eyes, ears, nose, and throat), cardiovascular, dermatologic, lymphatic, respiratory, gastrointestinal, genitourinary, musculoskeletal, and neurologic systems.

A brief physical examination will include general appearance, cardiovascular, dermatologic, respiratory, gastrointestinal, musculoskeletal, and neurologic assessments.

Height will be recorded at Screening only. Weight will be recorded at Screening and then every 4 weeks thereafter through Week 52, and at the second Q12W visit each year and at every End of Year visit during Years 2-5.

#### **9.8.8.6 Vector Shedding**

During the Post-Infusion Follow-Up period, subjects will undergo testing of various bodily samples to look for evidence of vector shedding for possible viral transmission. Bodily fluids will be tested by polymerase chain reaction (PCR). Fluids tested will include:

- Blood
- Saliva
- Semen
- Urine
- Stool

Vector shedding will also be extensively studied in the present clinical trial, at the time points indicated in [Table 9.1.1](#), [Table 9.1.2](#), [Table 9.1.3](#), [Table 9.1.4](#), and [Table 9.1.5](#). Testing will continue until at least 3 consecutive negative results are obtained. Testing of semen will continue at least through Week 12, even if 3 consecutive negative results have been recorded in that compartment prior to that time point. Subjects who have not had 3 consecutive negative semen samples by Week 52 should continue to have PCR testing in semen every 4 weeks (during Year 2) and every 6 weeks (during Years 3-5) until 3 consecutive negative samples are documented (or upon consultation between the Investigator and Medical Monitor). Subjects who meet the definition of treatment failure and wish to follow an abbreviated schedule (refer to [Section 12.7](#)) but who have not cleared vector shedding from all fluids must still provide samples for assessment every 4 weeks (during Year 2) or every 6 weeks (during Years 3-5) until vector shedding has cleared. Such subjects may provide samples on the designated study visit dates either at the sites or through use of a MN professional. Samples may be fractionated prior to shedding analysis in order to better characterize the presence, structure, and location of vector DNA and/or vector capsid within each matrix. If needed, the fractionation may be performed with samples collected



---

specifically for shedding analysis (saliva, blood, semen, urine, feces). Alternatively, the vector DNA characterization during shedding analysis may utilize already fractionated exploratory samples obtained from the above biofluids, such as exploratory plasma samples, exploratory PBMC samples, and red blood cells recovered during PBMC/plasma isolations.

Fractionation of semen to collect purified sperm separately from non-sperm cells may be performed in parallel at any visit where semen samples are collected. The shedding analysis of a fractionated semen sample will only be performed if vector DNA was detected in the whole semen sample for the same visit. Fractionation of semen during shedding analysis may be stopped if purified sperm tested positive for vector DNA on at least three visits, or if purified sperm tested negative for vector DNA on at least three consecutive visits.

Contraception use may need to be extended beyond 26 weeks in individual subjects based on observed vector shedding in semen. After 26 weeks, subjects may stop contraception use only if they have had 3 consecutive negative semen samples (upon consultation between the Investigator and Medical Monitor).

Details for sample collection and storage are provided in the Laboratory Manual.



## 10 REPORTING ADVERSE EVENTS

### 10.1 Safety Parameters and Definitions

Safety assessments will consist of monitoring and recording protocol-defined AEs and SAEs; measurement of protocol-specified hematology, clinical chemistry, and urinalysis variables; measurement of protocol-specified vital signs; and other protocol-defined events of special interest that are deemed critical to the safety evaluation of the study drug.

#### 10.1.1 Adverse Events

For this protocol, an adverse event (AE) is any untoward medical occurrence in a subject, temporally associated with the use of study intervention, whether or not considered related to the study intervention.

An AE can therefore be any unfavorable and unintended sign (including an abnormal laboratory finding), symptom, or disease (new or exacerbated) temporally associated with the use of study intervention.

Events meeting the AE definition include:

- Exacerbation of a chronic or intermittent pre-existing condition including either an increase in frequency and/or intensity of the condition.
- New conditions detected or diagnosed after study intervention administration even though it may have been present before the start of the study.
- Signs, symptoms, or the clinical sequelae of a suspected drug-drug interaction.

Events not meeting the AE definition include:

- Any clinically significant abnormal laboratory findings or other abnormal safety assessments which are associated with the underlying disease, unless judged by the investigator to be more severe than expected for the subject's condition.
- The disease/disorder being studied or expected progression, signs, or symptoms of the disease/disorder being studied, unless more severe than expected for the subject's condition.
- Medical or surgical procedure (eg, endoscopy, appendectomy): the condition that leads to the procedure is the AE.
- Situations in which an untoward medical occurrence did not occur (social and/or convenience admission to a hospital).
- Anticipated day-to-day fluctuations of pre-existing disease(s) or condition(s) present or detected at the start of the study that do not worsen.





### 10.1.1.1 Bleeding and Suspected Bleeding Events

All bleeding events and suspected bleeding events, regardless of the need for exogenous FVIII therapy as treatment, should be captured in subject diaries and recorded on the designated bleeding eCRF. Bleeding events and suspected bleeding events should not be reported as adverse events, with the following exception:

- All bleeding events and suspected bleeding events which meet one or more of the criteria for being serious (refer to Section 10.2) should be reported as serious adverse events (whether or not they are bleeding events that are normal sequelae of hemophilia, and whether or not they required exogenous FVIII as treatment).

### 10.2 Serious Adverse Events

A serious adverse event (SAE) is any untoward medical occurrence that, at any dose:

- Results in death
- Is life-threatening

*Note: Life-threatening refers to an event in which the subject was at risk of death at the time of the event. It does not refer to an event, which hypothetically might have caused death, if it were more severe.*

- Requires inpatient hospitalization or prolongation of existing hospitalization

Note: In general, hospitalization signifies that the subject has been detained (usually involving at least an overnight stay) at the hospital or emergency ward for observation and/or treatment that would not have been appropriate in the physician's office or outpatient setting. If the investigational product preparation, infusion, and post-infusion observation period require transfer to an inpatient setting for completion, in the absence of an AE, this will not be considered an SAE.

Complications that occur during hospitalization are AEs. If a complication prolongs hospitalization, the event is serious.

Hospitalization for elective treatment of a pre-existing condition that did not worsen from baseline is not considered an AE.

- Results in persistent or significant disability or incapacity
- Is a congenital anomaly or birth defect in the child or fetus of a subject exposed to IP prior to conception or during pregnancy
- Is an important medical event or reaction – that, based on medical judgment, may jeopardize the subject or require medical/surgical intervention to prevent one of the other outcomes listed above (eg, anaphylaxis)



### **10.2.1 Events of Special Interest (EOSI)**

The following EOSI need to be reported to the Sponsor within 24 hours of site awareness, irrespective of seriousness, severity or causality:

- Elevation of ALT  $\geq 1.5x$  ULN or ALT  $> ULN$  &  $>2x$  baseline value, regardless of whether that elevation triggers an initiation or modification of oral corticosteroid treatment
- Thromboembolic event
- Systemic hypersensitivity, anaphylactic, or anaphylactoid reactions (refer to Appendix 1)

### **10.3 Methods and Timing for Capturing and Assessing Safety Parameters**

#### **10.3.1 Adverse Event Reporting Period**

The study AE reporting period is as follows:

- After informed consent but prior to initiation of study drug, only SAEs associated with any protocol-imposed interventions will be collected. AEs occurring during this time period should be recorded on the Medical History eCRF.
- After informed consent is obtained and following infusion of study drug, the reporting period for all non-serious AEs and SAEs begins and continues for approximately 5 years or until study discontinuation/termination, whichever is longer.

The criteria for determining, and the reporting of SAEs is provided in Section [10.2](#).

#### **10.3.2 Eliciting Adverse Events**

Care will be taken not to introduce bias when detecting AEs and/or SAEs. Open-ended and non-leading verbal questioning of the subject is the preferred method to inquire about AE occurrences. The Investigator will record all relevant AE/SAE/EOSI information in the subject's medical record and AE Case Report Form (eCRF).

#### **10.3.3 Assessment of Seriousness, Severity, and Causality**

The Investigator responsible for the care of the subject or medically qualified designee will assess AEs for severity, relationship to study drug, and seriousness (refer to Section [10.2](#) for SAE definitions). These assessments must be made by a study clinician with the training and authority to make a diagnosis (eg, MD/DO, physician's assistant, nurse practitioner, or DDS).



### 10.3.3.1 Seriousness

The Investigator will assess if an AE should be classified as “serious” based on the seriousness criteria enumerated in Section 10.2. Seriousness serves as a guide for defining regulatory reporting obligations.

### 10.3.3.2 Severity

Severity (as in mild, moderate, or severe headache) is not equivalent to seriousness, which is based on subject/event outcome or action criteria usually associated with events that pose a threat to a subject’s life or functioning. The Investigator will determine the severity of each AE, SAE and EOSI using the NCI CTCAE v4.03. Adverse events that do not have a corresponding CTCAE term will be assessed according to the general guidelines for grading used in the CTCAE v4.03 as stated in Table 10.3.3.2.1.

**Table 10.3.3.2.1: Adverse Event Grading (Severity) Scale**

| Grade | Description  |   |
|-------|--|---|
| 1     | Mild: asymptomatic or mild symptoms; clinical or diagnostic observations only; intervention not indicated  |   |
| 2     | Moderate: minimal, local or noninvasive intervention indicated; limiting age-appropriate instrumental activities of daily living (ADL) <sup>a</sup>                                |   |
| 3     | Severe or medically significant but not immediately life-threatening; hospitalization or prolongation of hospitalization indicated; disabling; limiting self-care ADL <sup>b</sup> |   |
| 4     | Life threatening consequences; urgent intervention indicated   | Grade 4 and 5 AEs should always be reported as SAEs |
| 5     | Death related to AE  |   |

<sup>a</sup> Instrumental ADL refer to the following examples: preparing meals, shopping for groceries or clothes, using the telephone, managing money.

<sup>b</sup> Self-care ADL refer to the following examples: bathing, dressing and undressing, feeding oneself, using the toilet, taking medications, not bedridden.

### 10.3.3.3 Causality

The Investigator will determine the relationship of an AE to the study drug and will record it on the source documents and AE eCRF. To ensure consistency of causality assessments, Investigators should apply the guidance in Table 10.3.3.3.1.

**Table 10.3.3.3.1: Causality Attribution Guidance**

| <b>Relationship</b> | <b>Description</b>   |
|---------------------|--|
| Not Related         | <ul style="list-style-type: none"> <li>• Exposure to the IP has not occurred</li> </ul> <p style="text-align: center;"><b>OR</b></p> <ul style="list-style-type: none"> <li>• The administration of the IP and the occurrence of the AE are not reasonably related in time</li> </ul> <p style="text-align: center;"><b>OR</b></p> <ul style="list-style-type: none"> <li>• The AE is considered likely to be related to an etiology other than the use of the IP; that is, there are no facts, evidence, or arguments to suggest a causal relationship to the IP.</li> </ul>  |
| Related             | <ul style="list-style-type: none"> <li>• The administration of the IP and the occurrence of the AE are reasonably related in time</li> </ul> <p style="text-align: center;"><b><u>AND</u></b></p> <ul style="list-style-type: none"> <li>• The AE could possibly be explained by factors or causes other than exposure to the IP</li> </ul> <p style="text-align: center;"><b><u>OR</u></b></p> <ul style="list-style-type: none"> <li>• The administration of IP and the occurrence of the AE are reasonably related in time</li> </ul> <p style="text-align: center;"><b><u>AND</u></b></p> <ul style="list-style-type: none"> <li>• The AE is more likely explained by exposure to the IP than by other factors or causes.</li> </ul> |

Factors suggestive of a causal relationship could include (but are not limited to):

- Plausible temporal relationship
- Absence of alternative explanations
- Rarity of event in a given patient or disease state
- Absence of event prior to study drug exposure
- Consistency with study product pharmacology
- Known relationship to underlying mechanism of study drug action
- Similarity to adverse reactions seen with related drug products
- Abatement of AE with discontinuation of study drug, and/or recurrence of AE with reintroduction of study drug



The Investigator's assessment of causality for individual AE reports is part of the study documentation process. Regardless of the Investigator's assessment of causality for individual AE reports, the Sponsor will promptly evaluate all reported SAEs against cumulative product experience to identify and expeditiously communicate possible new safety findings to Investigators and applicable regulatory authorities.

## **10.4 Procedures for Recording Adverse Events**

### **10.4.1 Recording Adverse Events on a eCRF**

Investigators should use precise medical terminology when recording AEs or SAEs on the AE eCRF. Avoid colloquialisms and abbreviations.

Record only one diagnosis, sign, or symptom per event field on the AE eCRF (eg, nausea and vomiting should not be recorded in the same entry, but as 2 separate entries).

In order to classify AEs and diseases, preferred terms will be assigned by the Sponsor to the original terms entered on the AE eCRF, using MedDRA (Medical Dictionary for Regulatory Activities) terminology.

#### **10.4.1.1 Diagnosis versus Signs and Symptoms**

The Investigator will attempt to establish a diagnosis of the event based on signs, symptoms, and/or other clinical information. Whenever possible, the diagnosis (not the individual signs/symptoms) will be documented as the AE/SAE. Using accepted medical terminology, enter the diagnosis (if known). If not known, enter sign(s) and/or symptom(s). If a diagnosis subsequently becomes available, then this diagnosis should be entered on the AE (or SAE, as appropriate) eCRF, replacing the original entries where appropriate.

#### **10.4.1.2 Adverse Events Occurring Secondary to Other Events**

In general, AEs occurring secondary to other events (eg, cascade events) should be identified by their primary cause. For example, if severe diarrhea is known to have resulted in dehydration, it is sufficient to record only diarrhea as an AE or SAE on the AE eCRF. However, medically important events that may be linked and/or separated in time should be recorded as independent events on the AE eCRF. For example, if severe hemorrhage leads to renal failure, both events should be recorded separately on the AE eCRF.

#### **10.4.1.3 Persistent or Recurrent Adverse Events**

A persistent AE (duration of adverse event > 7 days) is one that extends continuously, without resolution, between subject evaluation time points. Events that change in severity



necessitate the recording of an additional AE. AEs that do not have a change in severity should be recorded only once on the eCRF.

A recurrent AE is one that occurs and resolves between subject evaluation time points, but then subsequently recurs. All recurrences of the AE should be recorded on the AE eCRF. For example, if a subject has an adverse event of ALT increased that subsequently resolves, but the subject's ALT increases again, that should be reported as two adverse events – the initial ALT increase, and the second ALT increase.

#### **10.4.1.4 Abnormal Laboratory Values**

Laboratory test results will be recorded on the laboratory results pages of the eCRF, or appear on electronically produced laboratory reports submitted directly from the central laboratory, if applicable.

Any laboratory result abnormality fulfilling the criteria for a SAE or EOSI should be reported as such, and recorded in the AE eCRF.

Any laboratory result abnormality of CTCAE Grade 4 or 5 should be recorded as an SAE in the AE eCRF.

A clinical laboratory abnormality is considered clinically significant and should be documented as an AE if not refuted by a repeat test to confirm the abnormality and **any** one or more of the following conditions is met:

- Accompanied by clinical symptoms
- Requiring a change in concomitant therapy (eg, addition of, interruption of, discontinuation of, or any other change in a concomitant medication, therapy or treatment).
- The abnormality suggests a disease and/or organ toxicity
- The abnormality is of a degree that requires active management (eg, change of dose, discontinuation of study drug, more frequent follow-up assessments, further diagnostic investigation, etc.)

**This applies to** any protocol and non-protocol specified safety and efficacy laboratory result from tests performed after the first dose of study medication that falls outside the laboratory reference range and meets the clinical significance criteria.

**This does not apply to** any abnormal laboratory result that falls outside the laboratory reference range but that does not meet the clinical significance criteria (these will be analyzed and reported as laboratory abnormalities), those that are considered AEs of the type



explicitly exempted by the protocol, or those which are a result of an AE that has already been reported.

For purposes of this study, laboratory tests showing a decreased level of FVIII activity should not be reported as adverse events unless there is an impact to clinical outcomes (eg, increased rate of bleeding, worsening of joint disease).

#### **10.4.1.5 Pre-existing Conditions**

A pre-existing condition is one that is present prior to administration of BMN 270. Such conditions should be recorded as medical history on the appropriate eCRF.

A pre-existing condition should be recorded as an AE or SAE during the study **only** if the frequency, intensity, or character of the condition worsens during the study period. It is important to convey the concept that a pre-existing condition has changed by including applicable language in the verbatim description of the event (eg, *more frequent* headaches).

#### **10.4.1.6 General Physical Examination Findings**

At screening, any clinically significant abnormality should be recorded as a pre-existing condition (refer to Section 10.4.1.5). During the study, any new clinically significant findings and/or abnormalities discovered on physical examination that meet the definition of an AE (or an SAE) must be recorded and documented as an AE or SAE on the AE eCRF.

#### **10.4.1.7 Hospitalization, Prolonged Hospitalization, or Surgery**

Any AE that results in hospitalization or prolonged hospitalization should be documented and reported as an SAE unless specifically instructed otherwise in this protocol (refer to Section 10.2).

There are some hospitalization scenarios that do not require reporting as an SAE when there is no occurrence of an AE. These scenarios include planned hospitalizations or prolonged hospitalizations to:

- Perform a protocol-mandated efficacy measurement
- Undergo a diagnostic or elective surgical procedure for a pre-existing medical condition that has not worsened
- Insert an in-dwelling IV catheter (such as a Port-a-Cath or other brand, if applicable) for administration of study drug or FVIII replacement therapy
- Receive scheduled therapy (study drug or otherwise) for the study indication





#### **10.4.1.8 Deaths**

All deaths that occur during the AE reporting period (refer to Section 10.3.1), regardless of attribution, will be recorded on the AE eCRF and expeditiously reported to the Sponsor as an SAE.

When recording a death, the event or condition that caused or contributed to the fatal outcome should be recorded as the single medical concept on the eCRF. If the cause of death is unknown and cannot be ascertained at the time of reporting, record “Unexplained Death” or “Death of Unknown Cause” on the AE eCRF.

#### **10.4.1.9 Pregnancy**

Although not an AE per se, pregnancy in the partner of a subject taking trial medication should be reported expeditiously to the Sponsor to facilitate outcome monitoring by the Sponsor. Pregnancy in partner should be reported during the period up to 5 years after viral infusion.

Pregnancy in a partner should be reported within 24 hours of the site becoming aware of the pregnancy by entering the information on the Pregnancy eCRF and submitting to BPV within 24 hours of the site becoming aware of the event. The Investigator must make every effort to follow the subject’s partner (with that partner’s consent) through resolution of the pregnancy (delivery or termination) and to report the resolution on the Pregnancy Follow-up eCRF. In the event of pregnancy in the partner of a study subject, the Investigator should make every reasonable attempt to obtain the woman’s consent for release of protected health information.

Abortion, whether therapeutic or spontaneous, should always be classified as an SAE (as the Sponsor considers these to be medically significant), recorded on the AE eCRF, and expeditiously reported to the Sponsor as an SAE.

### **10.5 Reporting Requirements**

#### **10.5.1 Expedited Reporting Requirements**

All SAEs and EOSI that occur during the course of the AE Reporting Period (refer to Section 10.3.1), whether or not considered related to study drug, must be reported by entering the information in the AE eCRF and submitting to BPV within 24 hours of the site becoming aware of the event. Investigators should not wait to collect information that fully documents the event before notifying BPV of an SAE. BioMarin may be required to report certain SAEs to regulatory authorities within 7 calendar days of being notified about the event; therefore, it is important that Investigators submit any information requested by BioMarin as soon as it becomes available. IND safety reports will be submitted within 7 calendar days for





fatal or life-threatening unexpected suspected adverse reactions (SUSARs) and within 15 calendar days for other non-life-threatening SUSARs

The Sponsor is responsible for identifying, preparing and reporting all SUSARs to the relevant competent authorities, ethics committees and Investigators in accordance with the requirements identified in the Clinical Trials Regulations.

If the EDC is unavailable, all SAEs should be reported to BPV by completing the SAE Report Form and faxing or emailing the completed form to BPV within 24 hours of the site becoming aware of the event. Once the EDC is available, the information should be entered in the AE eCRF.

### **10.5.2 Institutional Review Board or Independent Ethics Committee Reporting Requirements**

Reporting of SAEs to the Independent Ethics Committee (IEC) or Institutional Review Board (IRB) will be done in compliance with the standard operating procedures and policies of the IEC/IRB and with applicable regulatory requirements. Adequate documentation must be obtained by BioMarin showing that the IEC/IRB was properly and promptly notified as required.

### **10.6 Follow-up of Subjects after Adverse Events**

After the initial AE/SAE/EOSI report, the Investigator is required to proactively follow each subject at subsequent visits/contacts. All AEs/SAEs/EOSI will be followed until resolution, stabilization, the event is otherwise explained, or the subject is lost to follow-up. Resolution of AEs/SAEs/EOSI (with dates) should be documented on the AE eCRF and submitted to BioMarin Pharmacovigilance and in the subject's medical record to facilitate source data verification.

For some SAEs and EOSI, the Sponsor may follow up by telephone, fax, electronic mail, and/or a monitoring visit to obtain additional case details (eg, hospital discharge summary, consultant report, or autopsy report) deemed necessary to appropriately evaluate the SAE or EOSI report.

### **10.7 Post-Study Adverse Events**

At the last scheduled visit, the Investigator should instruct each subject to report, to the Investigator and/or to BPV directly, any subsequent SAEs that the subject's personal physician(s) believes might be related to prior study drug.



The Investigator should notify the study Sponsor of any death or SAE occurring at any time after a subject has discontinued or terminated study participation, if the Investigator believes that the death or SAE may have been related to prior study drug. The Sponsor should also be notified if the Investigator should become aware of the development of cancer or of a congenital anomaly in a subsequently conceived offspring of a subject that participated in this study.

### **10.8 Urgent Safety Measures**

The regulations governing clinical trials state that the Sponsor and Investigator are required to take appropriate urgent safety measures to protect subjects against any immediate hazards that may affect the safety of subjects, and that the appropriate regulatory bodies should be notified according to their respective regulations. According to the European Union (EU) Clinical Trial Directive 2001/20/EC, "...in the light of the circumstances, notably the occurrence of any new event relating to the conduct of the trial or the development of the investigational medicinal product where that new event is likely to affect the safety of the patients, the Sponsor and the Investigator shall take appropriate urgent safety measures to protect the patients against any immediate hazard. The Sponsor shall forthwith inform the competent authorities of those new events and the measures taken and shall ensure that the IRB/IEC/REB is notified at the same time."

The reporting period for these events which may require the implementation of urgent safety measures is the period from the time of signing of the ICF through the completion of the last study visit or at the Early Termination Visit (ETV). Investigators are required to report any events which may require the implementation of urgent safety measures to BioMarin within 24 hours.

Examples of situations that may require urgent safety measures include discovery of the following:

- Lack of study scientific value, or detrimental study conduct or management
- Discovery that the quality or safety of the IP does not meet established safety requirements



---

### 10.9 BioMarin Pharmacovigilance Contact Information

Contact information for BioMarin Pharmacovigilance is as follows:

BioMarin Pharmaceutical Inc.

Address 105 Digital Drive  
Novato, CA 94949  
Phone: +1 (415) 506-6179  
Fax: +1 (415) 532-3144  
E-mail: [drugsafety@bmrn.com](mailto:drugsafety@bmrn.com)

The Investigator is encouraged to discuss with the Medical Monitor any AEs for which the issue of seriousness is unclear or questioned. Contact information for the Medical Monitor is as follows:

Name: PI [redacted] MD, MPhil  
Address: 105 Digital Drive  
Novato, CA 94949 USA  
Phone: PI [redacted]  
E-mail: PI [redacted]



## **11 APPROPRIATENESS OF MEASUREMENTS**

The measures of efficacy to be used in this study are standard, ie, widely used and generally recognized as reliable, accurate, and relevant (able to discriminate between effective and ineffective agents). The measures of safety used in this study are routine clinical and laboratory procedures.

The chromogenic substrate FVIII assay and the one-stage clotting FVIII assay are both validated and utilize CE marked reagents. The exploratory FVIII activity assay will be used for exploratory purposes only.



## 12 STUDY PROCEDURES

### 12.1 Prestudy

An ICF must be signed and dated by the patient, the Investigator or designee and witness (if required) before any study-related procedures are performed.

### 12.2 Screening Visit

Screening assessments should be performed within 28 days of BMN 270 infusion (and must be performed within 42 days prior to BMN 270 infusion), while baseline assessments will take place within 7 days prior to BMN 270 infusion (Day 1). Should the screening visit occur within 30 days of the drug infusion, physical examination, vital signs, blood chemistry, LTs, hematology, urine tests, and coagulation tests do not need to be repeated at Baseline.

The following procedures will be performed during the Screening Period:

- Demographics (age, sex, race, ethnicity)
- Full medical history, including hemophilia A history, Hepatitis B, Hepatitis C, and HIV. Subjects with a history of hepatitis B or hepatitis C will be asked for information about the treatments received. Any prior pharmacokinetics information obtained while the subject was receiving prophylactic or on-demand FVIII therapy prior to the study should also be collected.
- Complete Physical Examination
- Height and weight
- Vital Signs (systolic and diastolic blood pressure, heart rate, respiration rate, and temperature)
- Assessment of Adverse Events and Concomitant Medications
- Documentation of bleeding episodes and FVIII usage (by either subject or clinical information) for the previous 12 months
  - Further information on details to be included in documentation of previous bleeding episodes and FVIII usage, refer to the On Site File Binder.
- Distribution of subject diaries and training in diary completion
- Electrocardiogram
- Liver Ultrasound
- Samples for hFVIII Assays
  - Baseline FVIII activity – chromogenic substrate FVIII assay
  - Baseline FVIII activity level – one-stage clotting FVIII assay

- hFVIII coagulation activity exploratory assay (collected but not tested prior to enrollment)
- hFVIII inhibitors (Bethesda assay with Nijmegen modification)
- hFVIII total antibody assay (collected but not tested prior to enrollment)
- hFVIII protein assay (collected but not tested prior to enrollment)
- Blood sample for AAV5 total antibody (TAb) assay
- Screen for Hepatitis B, Hepatitis C, and HIV if required (subjects with documented negative results 30 days prior to informed consent being obtained do not need to be retested)
  - Hepatitis B screening should include HBsAg, HBsAb, and HBcAb.
- Blood chemistry, hematology, and coagulation tests (refer to [Table 9.8.8.2.1](#))
- Urine Tests (refer to [Table 9.8.8.2.1](#))
- Liver Tests (refer to [Table 9.8.8.3.1](#))
- Blood samples for Biomarker testing (including HLA genotyping and FVIII genotyping status)

### 12.2.1 “Smart Rescreening” Visit

Subjects who undergo smart rescreening must complete the rescreening assessments and receive the infusion within 90 days of signing the original consent. Subjects who do not complete dosing within 90 days will be required to re-consent and undergo all screening procedures. Subjects may not undergo smart rescreening more than once.

If a patient has to be screened again because the original assessments have fallen out of the 28 + 14 day period allowed for Screening (refer to Section [12.2](#)), then only the following assessments need to be performed (rather than the full list indicated in Section [12.2](#)) for the patient to be successfully re-screened for the study:

- Vital signs
- Assessment of Adverse Events and Concomitant Medications
- Documentation of bleeding episodes and FVIII usage (by either subject or clinical information)
- hFVIII Assays (only the hFVIII inhibitor level (Bethesda assay with Nijmegen modification))
- AAV5 Total Antibody assay
- Blood chemistry, hematology, and coagulation tests (refer to [Table 9.8.8.2.1](#))

- Urine Tests (refer to [Table 9.8.8.2.1](#))
- Liver Tests (refer to [Table 9.8.8.3.1](#))

### 12.3 Baseline Visit

Baseline values will be recorded from 1 to 7 days prior to the treatment visit. The following procedures will be performed during the Baseline Period:

- Brief physical examination
- Vital signs
- Assessment of Adverse Events and Concomitant Medications
- Documentation of bleeding episodes and FVIII usage (by either subject or clinical information)
- Blood sample for AAV5 TI assay
- Blood sample for AAV5 TAb assay
- Blood chemistry, hematology, and coagulation tests (refer to [Table 9.8.8.2.1](#))
- Urine Tests (refer to [Table 9.8.8.2.1](#))
- Liver Tests (refer to [Table 9.8.8.3.1](#))
- Samples for hFVIII Assays
  - Baseline FVIII activity – chromogenic substrate FVIII assay
  - Baseline FVIII activity level – one-stage clotting FVIII assay
  - hFVIII coagulation activity exploratory assay
  - hFVIII inhibitors (Bethesda assay with Nijmegen modification)
  - hFVIII total antibody assay
  - hFVIII protein assay
- PBMC collection for CTL baseline
- Von Willebrand Factor Antigen (VWF:Ag)
- Direct Thrombin test
- TGA Assay
- PCR of vector DNA in blood, saliva, urine, semen, and stools
- Exploratory biomarker assessments
- Haemo-QoL-A assessment
  - a. EQ-5D-5L



- Hemophilia Activities List (HAL)
- Work Productivity and Activity Impairment plus Classroom Impairment Questions: Hemophilia Specific (WPAI+CIQ:HS) questionnaire
- Patient Reported Outcomes, Burdens, and Experiences (PROBE) questionnaire

#### **12.4 Treatment Visit/BMN 270 Infusion Visit (Day 1)**

There will be one treatment visit for each subject. Subjects will remain in the clinic for at least 8 hours for the BMN 270 Infusion Visit. The following procedures will be performed during the BMN 270 Infusion Visit:

- Brief physical examination
- Assessment of Adverse Events and Concomitant Medications
- AAV5 TAb Assay (sample collected pre-infusion for analysis)
- Fasting lipid panel (blood triglycerides, total cholesterol, HDL cholesterol, and LDL cholesterol) (sample collected pre-infusion)
  - Subjects will fast for at least 8 hours prior to pre-infusion laboratory sampling on the day of the infusion visit.
- BMN 270 Infusion
- Vital Signs
  - Vital signs will be recorded prior to BMN 270 infusion and then every 15 minutes ( $\pm$  5 minutes) during BMN 270 infusion. Following infusion, vital signs will be monitored every 1 hour ( $\pm$  5 minutes) for at least 8 hours during the subject's stay in the clinic.
- PCR of vector DNA in blood, saliva, urine, semen, and stools
  - Collection of samples for PCR testing should occur between 2 and 24 hours after the BMN 270 infusion has been completed

In case of hypersensitivity or adverse drug reaction, safety assessment, including physical examination and vital signs, will be done and additional blood samples will be collected within 1 hour of the hypersensitivity reaction (eg, tryptase, C3, C3a, C4, C5, C5a, and cytokine bead array, as well as possible additional exploratory testing) and samples for IgE and cytokine bead array (and possible additional exploratory testing) between 8-24 hours after the reaction, if possible. In addition, a blood sample should be taken 1 week after the hypersensitivity reaction for assessment of the cytokine bead array. In-patient observation can be extended and additional blood samples can be collected if deemed necessary at the discretion of the Investigator and Medical Monitor.





## 12.5 BMN 270 Infusion Follow-Up Visits – Weeks 1-26

After BMN 270 has been infused, subjects will return to the study site every week ( $\pm$  48 hours) during Weeks 1-26, when the following procedures will be completed:

### 12.5.1 Once per week (Weeks 1 through 26)

The following procedures will be performed at one visit per week from Weeks 1 through 26:

- Brief physical examination (complete physical examination at Week 26)
- Assessment of Adverse Events and Concomitant Medications (including review of subject diary for bleeding and FVIII use)
- Vital Signs
- Liver Tests (refer to [Table 9.8.8.3.1](#))
  - LTs may be monitored more or less frequently (and in particular when ALT values are  $\geq 1.5x$  ULN or  $> ULN$  &  $> 2x$  baseline value) based on discussion between the Medical Monitor and the Investigator and review of subject data, but LTs will be monitored at least twice weekly during periods when a subject's ALT is  $\geq 3x$  ULN.
- Samples for FVIII Assays
  - FVIII activity level (chromogenic substrate FVIII assay)
  - FVIII activity level (one-stage clotting FVIII assay)
  - FVIII coagulation activity exploratory assay
  - Bethesda assay (with Nijmegen modification) for hFVIII inhibitor level
  - FVIII protein assay

### 12.5.2 Week 1 – Day 4

On Day 4 of Week 1, the following procedures will be performed:

- PCR of vector DNA in blood, saliva, urine, semen, and stools
- Liver Tests (refer to [Table 9.8.8.3.1](#))

### 12.5.3 Week 1 – Day 8

On Day 8, the following procedures will be performed, in addition to the weekly assessments required in Section [12.5.1](#):

- PCR of vector DNA in blood, saliva, urine, semen, and stools

**12.5.4 Every 2 Weeks (Week 2, 4, 6, 8, 10, 12, 14, 16, 18, 20, 22, 24, and 26)**

At Weeks 2, 4, 6, 8, 10, 12, 14, 16, 18, 20, 22, 24, and 26 the following procedure will be performed:

- PBMC collection

**12.5.5 Weeks 2, 4, 10, 16, 22, and 26**

At Weeks 2, 4, 10, 16, 22, and 26 the following procedure will be performed:

- Blood chemistry, hematology, and coagulation tests (refer to [Table 9.8.8.2.1](#))

**12.5.6 Weeks 2, 3, 4, 6, 8, 12, 16, 20, 24, and 26**

At Weeks 2, 3, 4, 6, 8, 12, 16, 20, 24, and 26, the following procedure will be performed:

- PCR of vector DNA in blood, saliva, urine, semen, and stools
  - Collection to occur until at least 3 consecutive negative results are obtained. Semen samples should continue to be collected and tested through Week 12, even if 3 consecutive negative results in that compartment have been recorded prior to that time point.

**12.5.7 Weeks 4, 12, and 26**

At Weeks 4, 12, and 26, the following procedure will be performed:

- Haemo-QoL-A assessment
- EQ-5D-5L
- HAL
- WPAI+CIQ:HS
- PROBE

**12.5.8 Every 4 Weeks (Weeks 4, 8, 12, 16, 20, and 24) Plus Week 26**

At Weeks 4, 8, 12, 16, 20, 24, and 26, the following procedures will be performed:

- Weight (not performed at Week 26)
- FVIII antibody titer

**12.5.9 Every 8 Weeks (Weeks 8, 16, and 24)**

At Weeks 8, 16, and 24, the following procedures will be performed:

- AAV5 TAb assay
- AAV5 TI assay

**12.5.10 Weeks 6, 13, 16, 20, 24, and 26**

At Weeks 6, 13, 16, 20, 24, and 26, the following procedures will be performed:

- Exploratory biomarker assessments

**12.5.11 Weeks 12 and 26**

At Weeks 12 and 26, the following procedure will be performed:

- Urine Tests (refer to [Table 9.8.8.2.1](#))

**12.5.12 Week 13 and 26**

At Weeks 13 and 26, the following procedures will be performed:

- Direct Thrombin test
- VWF:Ag

**12.5.13 Week 16**

At Week 16, the following procedure will be performed:

- Test for Hepatitis B and Hepatitis C reactivation (only in subjects with evidence of prior exposure to hepatitis B and/or hepatitis C)
  - Subjects who receive therapeutic oral corticosteroids prior to Week 16 do not need to complete the Week 16 reactivation assessment; instead, they will be tested for hepatitis B and hepatitis C reactivation at the time points listed in [Table 9.1.6](#).

**12.5.14 Week 20, 24, and 26**

At Week 20, 24, and 26, the following procedure will be performed:

- TGA Assay



## 12.6 Post-Infusion Follow-Up – Weeks 27-52

During Weeks 27-36, subjects will return to the study site weekly ( $\pm$  48 hours). During Weeks 37-52, subjects will return to the study site every 2 weeks (Week 38, 40, 42, 44, 46, 48, 50, and 52) ( $\pm$  1 week). At these visits, the following procedures will be completed:

### 12.6.1 Every Visit

At every visit (Weeks 27-36, 38, 40, 42, 44, 46, 48, 50, and 52), the following procedures will be performed:

- Physical examination
  - Brief physical examination should be performed at all weeks except Week 26, when a complete physical examination should be performed
- Assessment of Adverse Events and Concomitant Medications (including review of subject diary for bleeding and FVIII use)
- Vital Signs
- Liver Tests (refer to [Table 9.8.8.3.1](#))
  - LTs may be monitored more or less frequently (and in particular when ALT values are  $\geq 1.5x$  ULN or  $> ULN$  &  $> 2x$  baseline value) based on discussion between the Medical Monitor and the Investigator and review of subject data, but LTs will be monitored at least twice weekly during periods when a subject's ALT is  $\geq 3x$  ULN.
- FVIII Assays
  - FVIII activity level (chromogenic substrate FVIII assay)
  - FVIII activity level (one-stage clotting FVIII assay)
    - FVIII coagulation activity exploratory assay
    - Bethesda assay (with Nijmegen modification) for FVIII inhibitor level
    - FVIII protein assay

### 12.6.2 Weeks 28, 30, 32, 34, 36, 44, and 52

At Weeks 28, 30, 32, 34, 36, 44, and 52, the following procedure will be performed:

- PBMC collection

### 12.6.3 Every 4 Weeks (Weeks 28, 32, 36, 40, 44, 48, 52)

At Weeks 28, 32, 36, 40, 44, 48, and 52, the following procedure will be performed:

- Weight



#### **12.6.4 Weeks 32, 36, 44, and 52**

At Weeks 32, 36, 44, and 52, the following procedures will be performed:

- Blood chemistry, hematology, and coagulation tests (refer to [Table 9.8.8.2.1](#))
- FVIII antibody titer

#### **12.6.5 Weeks 32, 36, 40, 44, 48, and 52**

At Weeks 32, 36, 40, 44, 48, and 52, the following procedures will be performed:

- Exploratory biomarker assessments
- TGA Assay
- PCR of vector DNA in blood, saliva, urine, semen, and stools
  - Sample testing to occur until at least 3 consecutive negative sample results have been obtained. Subjects who have not had 3 consecutive negative semen samples by Week 52 should continue to have PCR testing of semen every 4 weeks until 3 consecutive negative samples are documented (or upon consultation between the Investigator and Medical Monitor).

#### **12.6.6 Week 32, 36, and 52**

At Week 32, 36, and 52, the following procedure will be performed:

- AAV5 TAb Assay
- AAV5 TI Assay

#### **12.6.7 Week 38 and 52**

At Weeks 38 and 52, the following procedures will be performed:

- Urine Tests (refer to [Table 9.8.8.2.1](#))
- Direct Thrombin test
- VWF:Ag

#### **12.6.8 Week 52**

At Week 52, the following procedures will be performed:

- Haemo-QoL-A assessment
- EQ-5D-5L
- HAL
- WPAI+CIQ:HS



- PROBE

### **12.7 Post-Infusion Follow-Up – Years 2-5**

During Years 2-5, at applicable sites, certain study assessments may be performed by a mobile nursing (MN) professional at the patient's home or another suitable location, such as their school or office, to improve access and convenience for patients participating in the study. The Sponsor may select a healthcare company that will be responsible for providing MN services for participating sites (the MN vendor). The MN vendor is responsible for ensuring that all MN professionals are licensed, qualified, and in good standing, as per applicable regulations, and that appropriate background checks have been performed. If the investigator at a participating site determines that MN services are appropriate for a patient and the patient gives written informed consent to participate in MN visits, the MN network will communicate with the patient and the patient's site. MN visits will be allowed for the Q4W (during Year 2) and Q6W (during Years 3-5) visits; the Q12W visits and End of Year visits during Years 2-5 will not be performed by an MN professional but will be done at the study site.

Subjects who do not respond to BMN 270 treatment (ie, treatment failure, manifesting as either failure to achieve FVIII activity  $\geq 5$  IU/dL by Week 52 or inability to maintain independence from prophylactic FVIII replacement therapy due to joint bleeding episodes, in the judgment of the Investigator) may, at the Investigator's discretion and after discussion with the Medical Monitor, follow an abbreviated visit schedule after Week 52 of the study by attending only the Q12W and End of Year visits during Years 2-5.

Subjects who meet the definition of treatment failure and wish to follow an abbreviated schedule but who have not cleared vector shedding from all fluids must still provide samples for assessment every 4 weeks (during Year 2) or every 6 weeks (during Years 3-5) until vector shedding has cleared. Such subjects may provide samples on the designated study visit dates either at the sites or through use of a MN professional.

During Years 2-5 of Post-Infusion Follow-up, the following procedures will be completed:

#### **12.7.1 Year 2 – Every 4 Weeks (not required for treatment failure)**

During Year 2, every 4 weeks ( $\pm 2$  weeks), the following procedures will be performed:

- Assessment of Adverse Events and Concomitant Medications (including review of subject diary for bleeding and FVIII use)

- Liver Tests (refer to [Table 9.8.8.3.1](#))
  - LTs may be monitored more or less frequently (and in particular when ALT values are  $\geq 1.5x$  ULN or  $> ULN$  &  $> 2x$  baseline value) based on discussion between the Medical Monitor and the Investigator and review of subject data, but LTs will be monitored at least twice weekly during periods when a subject's ALT is  $\geq 3x$  ULN.
- FVIII Assays
  - FVIII activity level (chromogenic substrate FVIII assay)
  - FVIII activity level (one-stage clotting FVIII assay)
  - FVIII coagulation activity exploratory assay
  - Bethesda assay (with Nijmegen modification) for FVIII inhibitor level
  - FVIII protein assay
- PCR of vector DNA in blood, saliva, urine, semen, and stools (if required)
  - Sample testing during Year 2 is not required if at least 3 consecutive samples are negative during the Post-Infusion Follow-Up period in Weeks 1-52. Subjects who have not had 3 consecutive negative semen samples by Week 52 should continue to have PCR testing of semen every 4 weeks during Years 2 until 3 consecutive negative samples are documented (or upon consultation between the Investigator and Medical Monitor).
  - Subjects who meet the definition of treatment failure and wish to follow an abbreviated schedule but who have not cleared vector shedding from all fluids must still provide samples for assessment every 4 weeks during Year 2 until vector shedding has cleared. Such subjects may provide samples on the designated study visit dates either at the sites or through use of a MN professional.

### **12.7.2 Years 3-5 – Every 6 Weeks (not required for treatment failure)**

During Years 3-5, every 6 weeks ( $\pm 2$  weeks), the following procedures will be performed:

- Assessment of Adverse Events and Concomitant Medications (including review of subject diary for bleeding and FVIII use)
- Liver Tests (refer to [Table 9.8.8.3.1](#))
  - LTs may be monitored more or less frequently (and in particular when ALT values are  $\geq 1.5x$  ULN or  $> ULN$  &  $> 2x$  baseline value) based on discussion between the Medical Monitor and the Investigator and review of subject data, but LTs will be monitored at least twice weekly during periods when a subject's ALT is  $\geq 3x$  ULN.
- FVIII Assays



- FVIII activity level (chromogenic substrate FVIII assay)
- FVIII activity level (one-stage clotting FVIII assay)
- FVIII coagulation activity exploratory assay
- Bethesda assay (with Nijmegen modification) for FVIII inhibitor level
  - If a subject tests positive in the Bethesda assay (with Nijmegen modification) during Years 3-5, a fresh sample should be collected within 4 weeks of the initial visit that had a positive result.
- FVIII protein assay
- PCR of vector DNA in blood, saliva, urine, semen, and stools (if required)
  - Sample testing during Years 3-5 is not required if at least 3 consecutive samples are clear by the end of Year 2. Subjects who have not had 3 consecutive negative semen samples by the end of Year 2 should continue to have PCR testing of semen every 6 weeks during Years 3-5 until 3 consecutive negative samples are documented (or upon consultation between the Investigator and Medical Monitor).
  - Subjects who meet the definition of treatment failure and wish to follow an abbreviated schedule but who have not cleared vector shedding from all fluids must still provide samples for assessment every 6 weeks during Years 3-5 until vector shedding has cleared. Such subjects may provide samples on the designated study visit dates either at the sites or through use of a MN professional.

### **12.7.3 Years 2-5 – Every 12 Weeks and End of Year Visits (required for all subjects)**

During Years 2-5, subjects will be asked to return to the study site for visits at the following study weeks ( $\pm 2$  weeks):

- Year 2 – Week 64, Week 76, Week 88, Week 104
- Year 3 – Week 116, Week 128, Week 140, Week 156
- Year 4 – Week 168, Week 180, Week 192, Week 208
- Year 5 – Week 220, Week 232, Week 244, Week 260

For each of these years, the last study visit listed (Week 104, Week 156, Week 208, and Week 260) will serve as an End of Year visit. The every 12 week and End of Year visits may not be performed remotely by MN services.





At the every 12 week and End of Year visits, the following procedures will be performed:

- Physical examination
  - Complete physical examination will be performed at the End of Year visits; brief physical examination may be performed at other visits.
- Weight (at Week 76, Week 128, Week 180, Week 232, and End of Year visits only)
- Assessment of Adverse Events and Concomitant Medications (including review of subject diary for bleeding and FVIII use)
- Liver Tests (refer to [Table 9.8.8.3.1](#))
  - LTs may be monitored more or less frequently (and in particular when ALT values are  $\geq 1.5x$  ULN or  $> ULN$  &  $> 2x$  baseline value) based on discussion between the Medical Monitor and the Investigator and review of subject data, but LTs will be monitored at least twice weekly during periods when a subject's ALT is  $\geq 3x$  ULN.
- FVIII Assays
  - FVIII activity level (chromogenic substrate FVIII assay)
  - FVIII activity level (one-stage clotting FVIII assay)
  - FVIII coagulation activity exploratory assay
  - Bethesda assay (with Nijmegen modification) for FVIII inhibitor level
    - If a subject tests positive in the Bethesda assay (with Nijmegen modification) during Years 3-5, a fresh sample should be collected within 4 weeks of the initial visit that had a positive result.
  - FVIII protein assay
- Blood chemistry, hematology, and coagulation tests (refer to [Table 9.8.8.2.1](#)) (at Week 76, Week 128, Week 180, Week 232, and End of Year visits only)
- Urine Tests (refer to [Table 9.8.8.2.1](#)) (at Week 76, Week 128, Week 180, Week 232, and End of Year visits only)
- Vital Signs
- AAV5 TAb Assay
- AAV5 TI Assay
- FVIII antibody titer
- Haemo-QoL-A assessment (at Week 76, Week 128, Week 180, Week 232, and End of Year visits only)



- EQ-5D-5L (at Week 76, Week 128, Week 180, Week 232, and End of Year visits only)
- HAL (at Week 76, Week 128, Week 180, Week 232, and End of Year visits only)
- WPAI+CIQ:HS (at Week 76, Week 128, Week 180, Week 232, and End of Year visits only)
- PROBE (at Week 76, Week 128, Week 180, Week 232, and End of Year visits only)
- Exploratory biomarker assessments
- PBMC collection
- VWF:Ag
- Direct Thrombin test
- TGA Assay
- PCR of vector DNA in blood, saliva, urine, semen, and stools (if required)
  - Sample testing during Years 2-5 is not required if at least 3 consecutive samples are negative during the Post-Infusion Follow-Up period in Weeks 1-52. Subjects who have not had 3 consecutive negative semen samples by Week 52 should continue to have PCR testing of semen every 4 weeks (during Year 2) or every 6 weeks (during Years 3-5) until 3 consecutive negative samples are documented (or upon consultation between the Investigator and Medical Monitor).

## 12.8 Early Termination Visit

The Early Termination visit will occur on the date the subject withdraws from the study, even if the date does not correspond to a protocol-specific visit.

If a subject leaves the study prior to the Week 260 visit, the subject will be asked to return to the study site and complete an Early Termination visit. At the Early Termination visit, as many of the following assessments as possible should be done:

- Physical examination
- Weight
- Assessment of Adverse Events and Concomitant Medications (including review of subject diary for bleeding and FVIII use)
- Vital Signs
- Blood chemistry, hematology, and coagulation tests (refer to [Table 9.8.8.2.1](#))
- Urine Tests (refer to [Table 9.8.8.2.1](#))

- Liver Tests (refer to [Table 9.8.8.3.1](#))
- FVIII Assays
  - FVIII activity level (chromogenic substrate FVIII assay)
  - FVIII activity level (one-stage clotting FVIII assay)
  - FVIII coagulation activity exploratory assay
  - Bethesda assay (with Nijmegen modification) for FVIII inhibitor level
  - FVIII protein assay
- AAV5 TAb Assay
- AAV5 TI Assay
- FVIII antibody titer
- Exploratory biomarker assessments
- PBMC collection
- VWF:Ag
- Direct Thrombin test
- TGA Assay
- PCR of vector DNA in blood, saliva, urine, semen, and stools
  - Sample testing at the ETV is not required if at least 3 consecutive samples were clear during the Post-Infusion Follow-Up period.
- Haemo-QoL-A assessment
- EQ-5D-5L
- HAL
- WPAI+CIQ:HS
- PROBE

## 12.9 End of Study

The study will end after the last subject yet to complete the last Long-Term Follow-Up visit (Week 260) does so, has transferred to another BMN 270 study, is withdrawn from the study, or discontinues from the study. BioMarin reserves the right to discontinue the study any time for clinical or administrative reasons and to discontinue participation of an individual Investigator or site for clinical or administrative reasons, including, but not limited to, poor enrollment or noncompliance with procedures of the protocol or GCP. In addition, the study



may be terminated if, in the opinion of BioMarin, the safety of the study subjects may be compromised.



### **13 DATA QUALITY ASSURANCE**

BioMarin personnel or designees will visit the study site prior to initiation of the study to review with the site personnel information about the IP, protocol and other regulatory document requirements, source document requirements, eCRFs, monitoring requirements, and procedures for reporting AEs, including SAEs.

At visits during and after the study, a CRA will monitor the site for compliance with regulatory documentation, with a focus on accurate and complete recording of data on eCRFs from source documents, adherence to protocol, randomization (if applicable), SAE reporting and drug accountability records.

Data quality control and analysis will be performed by BioMarin or a designee, based on a predefined analysis plan.



---

## 14 STATISTICAL METHODS AND DETERMINATION OF SAMPLE SIZE

### 14.1 Statistical and Analytical Plans

The statistical analysis plan (SAP) will provide additional details on the planned statistical analysis. Unless otherwise stated, all analyses will be performed using SAS.

#### 14.1.1 Interim Analyses

An interim analysis is planned after approximately 20 evaluable HIV-negative subjects have completed the Week 26 visit (or have discontinued study participation prior to Week 26). Data will be reviewed by the DMC, based on the SAP, and a formal recommendation will be made whether to continue the study as designed.

The primary efficacy endpoint for the interim analysis involves hFVIII activity, as measured by chromogenic substrate assay, achieved post-BMN 270 infusion.

The fallback procedure ([Wiens, 2005](#)) will be used to adjust for multiplicity of the interim analysis at Week 26 and the final analysis at Week 52 (regardless of the interim analysis results, the study is planned to continue upon the DMC's recommendation, and the final analysis will be performed at Week 52). At the final analysis at Week 52, the secondary efficacy endpoints will be tested hierarchically; the level of significance will be determined by the fallback procedure.

The secondary and tertiary endpoints will be summarized descriptively at the interim (Week 26) analysis.

The details of the interim analysis, including the control of Type I error rate, will be specified in the SAP.

#### 14.1.2 Procedures for Accounting for Missing, Unused and Spurious Data

Because the completeness of the data affects the integrity and accuracy of the final study analysis, every effort should be made to ensure complete, accurate, and timely data collection and, therefore, avoid missing data.

Missing data imputation and sensitivity analyses to assess the impact of missing data on the primary and secondary efficacy endpoints analyses are described in the following sections. Additional details regarding the handling of missing data will be provided in the SAP.

### 14.2 Primary Efficacy Endpoint

For the primary efficacy endpoint at Week 52 (ie, the change in the hFVIII activity during Weeks 49-52 post-BMN 270 infusion from baseline, as measured by chromogenic substrate



assay), a one-sample t-test will be used to test the null hypothesis that the change is 0 or less against the alternative hypothesis that the change is greater than 0. Descriptive summaries of the proportions of subjects whose FVIII activity during Weeks 49-52 is greater than or equal to select thresholds, such as 15, 25 and 30 IU/dL, and the confidence intervals of the proportions will also be provided.

For a subject with a missing value of the primary endpoint, the median value in the subject's last 4-week window containing a valid observation will be used. Additional analyses will be conducted to examine the sensitivity of the results to the handling of missing data, including analysis using observed cases, and a mixed model for repeated measures (MMRM) approach. Further detail will be provided in the SAP.

The analyses for the primary endpoint will be performed using the analysis populations as defined in Section 14.8.

### 14.3 Secondary Efficacy Endpoints

The primary analyses for the secondary endpoints will be performed on the 110 subjects in the mITT population who will be followed up for approximately 6 months in the non-interventional study 270-902 prior to their enrollment in 270-301. The baseline values will be derived from the prospectively collected data in 270-902.

For the first secondary efficacy endpoint at Week 52 (ie, the change in the annualized utilization (IU/kg) of exogenous FVIII replacement therapy during Weeks 5-52 post-BMN 270 infusion from baseline), a one-sample t-test will be performed to test the null hypothesis that the change is 0 or greater against the alternative hypothesis that the change is less than 0. The missing value of the change will be imputed as 0.

For the second secondary efficacy endpoint at Week 52 (ie, the change in ABR, annualized bleeding rate, during Weeks 5-52 post-BMN 270 infusion from baseline), a one-sample t-test will be performed to test for non-inferiority of BMN 270 against FVIII prophylaxis (ie, the baseline ABR calculated using subjects' data collected as part of 270-902) using a non-inferiority margin of 3.5, ie, to test the null hypothesis that the change is 3.5 or greater against the alternative hypothesis that the change is less than 3.5. If non-inferiority is demonstrated, the test for superiority of BMN 270 against FVIII prophylaxis will be performed. The missing value of the change will be imputed using the median value of the changes of all observed cases.

A sensitivity analysis is planned to analyze ABR using a generalized linear mixed model assuming negative binomial as the underlying distribution. The model will include period (pre- to post-BMN 270 infusion) as the only factor. The actual number of bleeding episodes



will be used as the independent variable with the time period adjustment (animalization) being implemented as the offset.

To assess the impact of missing data, analyses using observed case are planned as sensitivity analyses for the secondary endpoints. Multiple imputation methods may also be performed.

The primary and secondary efficacy hypotheses will be tested hierarchically according to the order described above. Multiple comparison procedures will be described in greater detail in the SAP.

#### **14.4 Immunogenicity**

Analysis of total and neutralizing antibody response and other immunological parameters will be primarily descriptive and involve both inter-subject and intra-subject comparisons.

#### **14.5 Pharmacodynamic Analyses**

Plasma FVIII protein concentrations and FVIII activities determined over the course of the study will primarily be evaluated and summarized with descriptive statistical measures (eg, mean, standard deviation, CV%, min, median, max).

#### **14.6 Safety Analysis**

The Medical Dictionary for Regulatory Activities terminology (MedDRA) will be used by the Sponsor to assign system organ class and preferred term classification to events and diseases, based on the original terms entered on the eCRF.

All AEs will be coded using the current version of MedDRA. The incidence of AEs will be summarized by system organ class, preferred term, relationship to study drug, and severity. A by-subject listing will be provided for those subjects who experience a serious AE (SAE), including death, or experience an AE associated with early withdrawal from the study or study drug.

Clinical laboratory data will be summarized by the type of laboratory test. For each clinical laboratory test, descriptive statistics will be provided on Baseline as well as all subsequent visits. Descriptive statistics for physical examination results and vital signs will also be provided.

Detailed statistical methods will be provided in the SAP.





## 14.7 Determination of Sample Size

Approximately one hundred and thirty (130) subjects may be dosed in the study. The sample size for this study is based on clinical and statistical considerations in order to provide sufficient data to assess both safety and efficacy of BMN 270.

For the primary endpoint, a sample size of 130 will provide at least 95% power to demonstrate that the change in hFVIII activity during Weeks 49-52 from baseline is greater than 0, assuming an effect size of 0.6, using a one-sample t-test with a 2-sided significance level of 0.05. The effect size of 0.6 is assumed based on Study 270-201 data. In Study 270-201 cohort 6E13, the mean (SD) of FVIII activity (IU/dL) at Week 52 (based on median values in a 4-week window around Week 52) were estimated as 103.8 (62.4), with a 95% confidence interval for the mean of (46.1, 161.5). Using the lower limit of the confidence interval and assuming a baseline value of 1 (the largest value allowed per the study's inclusion/exclusion criteria), the effect size of change from baseline is approximately 0.7. For the sample size calculation, an effect size of 0.6 is assumed.

For the secondary endpoints, the analysis will be performed utilizing exogenous FVIII use and bleeding episode data from the 110 subjects whose baseline data will be prospectively collected for approximately 6 months in the non-interventional study 270-902, prior to their enrollment in Study 270-301. An analytic sample size of 110 will provide at least 95% power to demonstrate that the change in the annualized utilization (IU/kg) of exogenous FVIII replacement therapy during Week 5 to Week 52 post-BMN 270 infusion from the baseline is less than 0, assuming an effect size of 0.6 conservatively, using one-sample t-test with a 2-sided significance level of 0.05.

For the analytic sample size calculation of the second secondary endpoint, ABR, it is assumed that the pre- and post-BMN 270 infusion population mean ABRs are 3.5 and 1 respectively, and the distribution of ABRs is negative binomial distribution with a dispersion parameter of 2.2. Given the underlying negative binomial distributions, the standard deviations of the pre- and post-BMN 270 infusion ABRs are calculated as 7.8 and 1.8 respectively. The mean (SD) of the change from the pre- to post-BMN 270 infusion ABRs are calculated as -2.5 (8) assuming the correlation between pre- and post-BMN 270 infusion ABRs is zero. Under this assumption, an analytic sample size of 110 will also have at least 95% power to demonstrate that the change in the annualized number of bleeding episodes requiring exogenous FVIII replacement treatment (ABR) during Week 5 to Week 52 of the study post-BMN 270 infusion from the baseline ABR is less than 3.5 (non-inferiority margin), using a one-sample t-test with a 2-sided significance level of 0.05. Under the same assumptions, a sample size of 110 will have approximately 90% power to



demonstrate that the change is less than 0, ie, superiority of BMN 270 against FVIII prophylaxis.

Overall, the planned sample size will have greater than 80% power for testing the primary and secondary efficacy endpoints hierarchically at the final analysis with a 2-sided significance level of 0.05.

#### **14.8 Analysis Populations**

The intention-to-treat (ITT) population is defined as all subjects who receive BMN 270 infusion, and the modified intention-to-treat (mITT) population is defined as subjects who receive BMN 270 infusion and are HIV-negative. The mITT population will be used for the primary efficacy analysis and ITT will be used for the supportive efficacy analysis. The ITT population will also be used for the safety analysis.

#### **14.9 Changes in the Conduct of the Study or Planned Analyses**

Only BioMarin may modify the protocol. Any change in study conduct considered necessary by the Investigator will be made only after consultation with BioMarin, who will then issue a formal protocol amendment to implement the change. The only exception is when an Investigator considers that a subject's safety is compromised without immediate action. In these circumstances, immediate approval of the chairman of the IRB/IEC/REB must be sought, and the Investigator should inform BioMarin and the full IRB/IEC/REB within 2 working days after the emergency occurs.

With the exception of minor administrative or typographical changes, the IRB/IEC/REB must review and approve all protocol amendments. Protocol amendments that have an impact on subject risk or the study objectives, or require revision of the ICF, must receive approval from the IRB/IEC/REB prior to their implementation.

When a protocol amendment substantially alters the study design or the potential risks or burden to subjects, the ICF will be amended and approved by BioMarin and the IRB/IEC/REB, and all active subjects must again provide informed consent.



## 15 DATA MONITORING COMMITTEE

An independent DMC will be convened for this study. The duties of the DMC will include:

- Conducting an ongoing review of individual subject safety and efficacy data during the study.
- Recommending whether to enroll subjects at a different dose level (not to exceed 6E13 vg/kg) based on emerging data from 270-301 and the overall risk/benefit analysis of BMN 270.
- Reviewing ongoing safety and efficacy data for comparability of drug manufacturing lots within 270-301 and between 270-201 and 270-301.
- Making other recommendations on the conduct and reporting of the trial based on their evaluation of clinical data.

Details on the composition of the committee, frequency of meetings, and other committee functions and parameters are included in the DMC Charter and in the Statistical Analysis Plan (SAP).



## **16 COSTS, COMPENSATION, AND SUBJECT INJURY**

There will be no charge to study subjects to be in this study. BioMarin will pay all costs of tests, procedures, and treatments that are part of this study. In addition, after IRB/IEC/REB approval, BioMarin may reimburse the reasonable cost of travel for study-related visits in accordance with BioMarin's travel and reimbursement policy. BioMarin will not pay for any hospitalizations, tests, or treatments for medical problems of any sort related solely to the study subject's disease. Costs associated with such hospitalizations, tests, and treatments should be billed and collected in the way that such costs are usually billed and collected outside the study.

The Investigator should contact BioMarin immediately upon notification that a study subject has been injured by the study drug or by procedures performed as part of the study. Any subject who experiences a study-related injury should be instructed by the Investigator to seek immediate medical treatment at a pre-specified medical institution if possible, or at the closest medical treatment facility if necessary. The subject should be given the name of a person to contact to seek further information about, and assistance with, treatment for study-related injuries. The treating physician should bill the subject's health insurance company or other third party payer for the cost of this medical treatment. If the cost of the medical treatment is not covered by health insurance or another third party that usually pays these costs, then either BioMarin or the institution may pay for reasonable and necessary medical services to treat the injuries caused by the study drug or study procedures. In some jurisdictions, BioMarin is obligated by law to pay for study-related injuries without prior recourse to third party payer billing and/or regardless of fault. If this is the case, BioMarin will comply with the law.



---

## 17 CASE REPORT FORMS AND SOURCE DOCUMENTS

Electronic case report forms will be provided for each subject. The Investigator must review and electronically sign the completed eCRF casebook to verify its accuracy.

eCRFs must be completed using a web-based application developed and validated. Study site personnel will be trained on the application and will enter the clinical data from source documentation. Unless explicitly allowed in the eCRF instructions, blank data fields are not acceptable.

In the event of an entry error, or if new information becomes available, the value will be corrected by deselecting the erroneous response and then selecting or entering the factual response. In compliance with ICH GCP Guidelines and 21 CFR Part 11, the system will require the personnel making the correction to enter a reason for changing the value. The documented audit trail will include the reason for the change, the original value, the new value, the time of the correction and the identity of the operator.

BioMarin's policy is that study data on the eCRFs must be verifiable to the source data, which necessitates access to all original recordings, laboratory reports, and subject records. In addition, all source data should be attributable (signed and dated). The Investigator must therefore agree to allow direct access to all source data. Subjects must also allow access to their medical records, and subjects will be informed of this and will confirm their agreement when giving informed consent. If direct source document verification of study data by the site monitor is prohibited by institutional policy or local law, then the Investigator must make available facilities and/or personnel to allow GCP-compliant source verification to occur. Examples of such methods include certified copies of records which have study data visible but sensitive information redacted, or other GCP-compliant means agreed between the Investigator and the Sponsor.

A site monitor designated by BioMarin will compare the eCRFs with the original source documents at the study site and evaluate them for completeness and accuracy before designating them as "Source Data Verified" (SDV). If an error is discovered at any time or a clarification is needed, the site monitor, or designee, will create an electronic query on the associated field. Site personnel will then answer the query by either correcting the data or responding to the query. The site monitor will then review the response and determine either to close the query or re-query the site if the response does not fully address the question. This process is repeated until all open queries have been answered and closed.

Before a subject's eCRF casebook can be locked, data fields must be source data verified and all queries closed. Refer to the Study Monitoring Plan for details on which fields must be



---

source data verified. The Investigator will then electronically sign the casebook, specifying that the information on the eCRFs is accurate and complete. The Data Manager, or designee, will then set the status of the forms, visits, and the entire casebook to Locked. Upon completion of the CSR, an electronic copy of each site's casebooks will be copied to a compact disk (CD) and sent to each site for retention with other study documents.



## **18 STUDY MONITORING AND AUDITING**

Qualified individuals designated by BioMarin will monitor all aspects of the study according to GCP and standard operating procedures for compliance with applicable government regulations. The Investigator agrees to allow these monitors direct access to the clinical supplies, dispensing, and storage areas and to the clinical files, including original medical records, of the study subjects, and, if requested, agrees to assist the monitors. The Investigator and staff are responsible for being present or available for consultation during routinely scheduled site visits conducted by BioMarin or its designees.

Members of BioMarin's GCP Compliance Department or designees may conduct an audit of a clinical site at any time before, during, or after completion of the study. The Investigator will be informed if an audit is to take place and advised as to the scope of the audit. Representatives of the FDA or other Regulatory Agencies may also conduct an audit of the study. If informed of such an inspection, the Investigator should notify BioMarin immediately. The Investigator will ensure that the auditors have access to the clinical supplies, study site facilities, original source documentation, and all study files.



## 19 RETENTION OF RECORDS

The Investigator must retain all study records required by BioMarin and by the applicable regulations in a secure and safe facility. The Investigator must consult a BioMarin representative before disposal of any study records, and must notify BioMarin of any change in the location, disposition or custody of the study files. The Investigator /institution must take measures to prevent accidental or premature destruction of essential documents, that is, documents that individually and collectively permit evaluation of the conduct of a study and the quality of the data produced, including paper copies of study records (eg, subject charts) as well as any original source documents that are electronic as required by applicable regulatory requirements.

All study records must be retained for at least 2 years after the last approval of a marketing application in the US or an ICH region and until (1) there are no pending or contemplated marketing applications in the U.S. or an ICH region or (2) at least 2 years have elapsed since the formal discontinuation of clinical development of the IP. The Investigator /institution should retain subject identifiers for at least 15 years after the completion or discontinuation of the study. Subject files and other source data must be kept for the maximum period of time permitted by the hospital, institution or private practice, but not less than 15 years. These documents should be retained for a longer period, however, if required by the applicable regulatory requirements or by a BioMarin agreement. BioMarin must be notified and will assist with retention should Investigator /institution be unable to continue maintenance of subject files for the full 15 years. It is the responsibility of BioMarin to inform the Investigator /institution as to when these documents no longer need to be retained.





## **20 USE OF INFORMATION AND PUBLICATION**

BioMarin recognizes the importance of communicating medical study data and therefore encourages the publication of these data in reputable, peer-reviewed scientific journals and at seminars or conferences. The details of the processes of producing and reviewing reports, manuscripts, and presentations based on the data from this study will be described in the Clinical Trial Agreement between BioMarin and the Investigator/Institution. Consideration for authorship of all publications will be based on compliance with the Uniform Requirements for Manuscripts Submitted to Biomedical Journals (“Uniform Requirements”) of the International Committee of Medical Journal Editors (ICMJE) ([http://www.icmje.org/ethical\\_1author.html](http://www.icmje.org/ethical_1author.html)) and good publication practices (GPP).

---

## 21 REFERENCES

Batts KP & Ludwig J. Chronic hepatitis: an update on terminology and reporting. *Am J Surg Pathol* 19:1409-1417. 1995.

Bedossa P, Pynard T, French METAVIR Cooperative Study Group. An algorithm for grading activity in chronic hepatitis C. *Hepatology* 24;289-293. 1996.

Berntorp E, Dolan G, Hay C, Linari S et al. European retrospective study of real-life haemophilia treatment. *Haemophilia*. 2017;23(1):105-114.

Berntorp E, Peake I, Budde U, Laffan M et. al. von Willebrand's disease: a report from a meeting in the Aland islands. *Haemophilia* 18 Suppl 6, 1-13. 2012.

Brooks R. EuroQol: the current state of play. *Health Policy*. 1996;37:53-72.

Chai-Adisaksopha C, Skinner M, Curtis R, et al. Psychometric Properties of the Patient Reported Outcomes, Burdens and Experiences (PROBE) Questionnaire. *Blood*. 2017;130:5645.

EuroQol Group. EuroQol – a new facility for the measurement of health-related quality of life. *Health Policy*. 1990;16:199-208.

George LA, Sullivan S, Teitel J, Cuker A et al. Preliminary results of a phase 1/2 trial of SPK-9001, a hyperactive FIX variant delivered by a novel capsid, demonstrate consistent factor IX activity levels at the lowest dose cohort. *Haemophilia* 22[Suppl. 4], 151-152. 2016.

Hay CR, DiMichele DM. The principal results of the International Immune Tolerance Study: a randomized dose comparison  
12. *Blood* 119[6], 1335-1344. 2012.

Haemo-QoL Study Group. Scoring Manual. Available at: <http://haemoqol.de/scoring/manual>. Last accessed 28 July 2017.

Kaufman RJ, Powell JS. Molecular approaches for improved clotting factors for hemophilia 1. *Blood* 122[22], 3568-3574. 2013.

Manno CS, Pierce GF, Arruda VR, Glader B et. al. Successful transduction of liver in hemophilia by AAV-Factor IX and limitations imposed by the host immune response. *Nat Med* 12[3], 342-347. 2006.



Miesbach W, Tangelder M, Klamroth R, Schutgens R et al. Updated results from a dose escalating study in adult patients with haemophilia B with AMT-060 (AAV5-hFIX) gene therapy. *Haemophilia* 22[Suppl. 4], 151-152. 2016.

Mingozzi F and High KA. Immune responses to AAV vectors: overcoming barriers to successful gene therapy. *Blood* 122[1], 23-36. 2013.

Nathwani AC, Reiss UM, Tuddenham EG, Rosales C et. al. Long-term safety and efficacy of factor IX gene therapy in hemophilia B. *N Engl J Med* 371[21], 1994-2004. 2014.

Nathwani AC, Rosales, C, McIntosh J, Rastegarlarlari G et. al. Long-term safety and efficacy following systemic administration of a self-complementary AAV vector encoding human FIX pseudotyped with serotype 5 and 8 capsid proteins. *Mol Ther* 19[5], 876-885. 2011.

Nathwani AC, Tuddenham EG. Epidemiology of coagulation disorders. *Baillieres Clin Haematol* 5[2], 383-439. 1992.

Pasi KJ, Rangarajan S, Kim B et al. Achievement of Normal Circulating Factor VIII Activity Following BMN 270 AAV5-FVIII Gene Transfer: Interim, Long-Term Efficacy and Safety Results from a Phase 1/2 Study in Patients with Severe Hemophilia A. *Blood* 130[Suppl. 1], 603. 2017.

Rangarajan S, Kim B, Lester W et al. Achievement of normal factor VIII activity following gene transfer with valoctocogene roxaparvovec (BMN 270): Long-term efficacy and safety results in patients with severe hemophilia A. *Haemophilia* 24[Suppl. 5], 65. 2018

Reilly M. WPAI Scoring. 2002. Available at: [http://www.reillyassociates.net/WPAI\\_Scoring.html](http://www.reillyassociates.net/WPAI_Scoring.html). Last accessed 28 July 2017.

Recht M, Neufeld EJ, Sharma VR, Solem CT et al. Impact of Acute Bleeding on Daily Activities of Patients with Congenital Hemophilia with Inhibitors and Their Caregivers and Families: Observations from the Dosing Observational Study in Hemophilia (DOSE). *Value in Health*. 2014;17:744-748.

Rentz A, Flood E, Altisent C, Bullinger M et al. Cross-cultural development and psychometric evaluation of a patient-reported health-related quality of life questionnaire for adults with haemophilia. *Haemophilia* 2008;14(5):1023-34.

Sampson HA, Muñoz-Furlong A, Campbell RL, et al. Second symposium on the definition and management of anaphylaxis: summary report—second National Institute of Allergy and Infectious Disease/Food Allergy and Anaphylaxis Network symposium. *J Allergy Clin Immunol* 2006;117:391-397.



Srivastava A, Brewer AK, Mauser-Bunschoten EP, Key NS et. al. Guidelines for the management of hemophilia 128. *Haemophilia* 19[1], e1-47. 2013.

Stonebraker JS, Brooker M, Amand RE, Farrugia A et. al. A study of reported factor VIII use around the world. *Haemophilia* 16[1], 33-46. 2010.

United States Department of Health and Human Services. Guidelines for the Use of Antiretroviral Agents in HIV-1-Infected Adults and Adolescents. 2014. Available at <https://aidsinfo.nih.gov/guidelines/html/1/adult-and-adolescent-arv-guidelines/458/plasma-hiv-1-rna--viral-load--and-cd4-count-monitoring>. Last accessed 28 July 2017.

Van Genderen FR, Westers P, Heijnen L, De Kleijn P et al. Measuring patients' perceptions on their functional abilities: validation of the Haemophilia Activities List. *Haemophilia*. 2006;12:36-46.

Wiens BL, Dmitrienko A. The fallback procedure for evaluating a single family of hypotheses. *J Biopharm Stat*. 2005; 15:929-942.



---

## 22 INVESTIGATOR RESPONSIBILITIES

### 22.1 Conduct of Study and Protection of Human Patients

In accordance with FDA Form 1572 and/or principles of ICH E6 GCP, the Investigator will ensure that:

- He or she will conduct the study in accordance with the relevant, current protocol and will only make changes in a protocol after notifying the sponsor, except when necessary to protect the safety, rights, or welfare of subjects.
- He or she will personally conduct or supervise the study.
- He or she will inform any potential subjects, or any persons used as controls, that the drugs are being used for investigational purposes, and he or she will ensure that the requirements relating to obtaining informed consent in 21 CFR Part 50 and/or ICH E6 sections 2.9 and 4.8 are met. As well, he or she will ensure that IRB/IEC review and approval in 21 CFR Part 56 and/or ICH E6 section 2.6 are met.
- He or she will report to the sponsor adverse experiences that occur in the course of the investigation in accordance with 21 CFR 312.64 and/or ICH E6 Section 4.11.
- He or she has read and understands the information in the Investigator's Brochure, including potential risks and side effects of the drug.
- His or her staff and all persons who assist in the conduct of the study are informed about their obligations in meeting the above commitments
- Adequate and accurate records in accordance with 21 CFR 312.62 and/or ICH E6 section 4.9 are kept, and those records are available for inspection in accordance with 21 CFR 312.68 and/or ICH E6 section 4.9.7.
- The IRB/EC/REB complies with the requirements of 21 CFR Part 56, ICH E6 Section 3.0, and other applicable regulations, and conducts initial and ongoing reviews and approvals of the study. He or she will also ensure that any change in research activity and all problems involving risks to human subjects or others are reported to the IRB/EC/REB. Additionally, he or she will not make any changes in the research without IRB/EC/REB approval, except where necessary to eliminate apparent immediate hazards to human subjects.
- He or she agrees to comply with all other requirements regarding the obligations of clinical Investigators and all other pertinent requirements in 21 CFR Part 312 and/or ICH E6.



**23 SIGNATURE PAGE**

**Protocol Title:** A Phase 3 Open-Label, Single Arm Study To Evaluate The Efficacy and Safety of BMN 270, an Adeno-Associated Virus Vector-Mediated Gene Transfer of Human Factor VIII in Hemophilia A Patients with Residual FVIII Levels  $\leq$  1 IU/dL Receiving Prophylactic FVIII Infusions

**Protocol Number:** 270-301 Amendment 3

I have read the forgoing protocol and agree to conduct this study as outlined. I agree to conduct the study in compliance with all applicable regulations and guidelines, including ICH E6, as stated in the protocol, and other information supplied to me.

\_\_\_\_\_  
Investigator Signature Date

Printed name: \_\_\_\_\_

Accepted for the Sponsor: 

\_\_\_\_\_  
Medical Monitor Signature Date

Printed name:  Clinical Sciences



---

**24 APPENDIX 1: SAMPSON'S ANAPHYLAXIS CRITERIA**

According to the National Institute of Allergy and Infectious Disease/Food Allergy and Anaphylaxis Network (NIAID/FAAN) Second Symposium on the definition and management of anaphylaxis, anaphylaxis is highly likely when any one of the following 3 criteria are fulfilled:

1. Acute onset of an illness (minutes to several hours) with involvement of the skin, mucosal tissue, or both (eg, generalized hives, pruritus or flushing, swollen lips-tongue-uvula)  
*AND AT LEAST ONE OF THE FOLLOWING*
  - a. Respiratory compromise (eg, dyspnea, wheeze-bronchospasm, stridor, reduced peak expiratory flow [PEF], hypoxemia)
  - b. Reduced blood pressure (BP) or associated symptoms of end-organ dysfunction (eg, hypotonia [collapse], syncope, incontinence)
2. Two or more of the following that occur rapidly after exposure to a likely allergen for that patient (minutes to several hours):
  - a. Involvement of the skin-mucosal tissue (eg, generalized hives, itch-flush, swollen lips-tongue-uvula)
  - b. Respiratory compromise (eg, dyspnea, wheeze-bronchospasm, stridor, reduced PEF, hypoxemia)
  - c. Reduced BP or associated symptoms (eg, hypotonia [collapse], syncope, incontinence)
  - d. Persistent gastrointestinal symptoms (eg, crampy abdominal pain, vomiting)
3. Reduced BP after exposure to known allergen for that patient (minutes to several hours):
  - a. Infants and children: low systolic blood pressure (age specific) or greater than 30% decrease in systolic BP
  - b. Adults: systolic BP of less than 90 mmHg or greater than 30% decrease from that person's baseline.

Source: [Sampson, 2006](#).





## 25 PROTOCOL AMENDMENT TEXT REVISIONS

The following table summarizes the revisions made to the protocol and relates the changes to the appropriate rationale (see pages 2-4). Added text is indicated by underlined font and deleted text is indicated by ~~strike through~~ font.

| Section No./Title                  | Revision  | Rationale   |
|------------------------------------|---|-------------|
| 2/Synopsis (Objectives)            | <p>The primary efficacy objective of the study is to:</p> <ul style="list-style-type: none"> <li>Assess the efficacy of BMN 270 defined as FVIII activity, as measured by <del>one-stage clotting</del> <u>chromogenic substrate</u> assay, during Weeks 49-52 following intravenous infusion of BMN 270</li> </ul>   | 8           |
| 2/Synopsis (Study Design and Plan) | <p>Approximately 130 adult subjects with severe HA will receive a 6E13 vg/kg dose of BMN 270 as a single intravenous infusion. Approximately 20 subjects will enroll in the study with at least 12 months of well-documented high-quality historical data concerning previous bleeding episodes and exogenous FVIII usage, while approximately 110 subjects will enroll in the study after having completed approximately 6 months' participation in the BioMarin-sponsored non-interventional study 270-902, <u>in which bleeding and FVIII use data prior to gene therapy will be prospectively collected.</u></p> <p><u>In order to minimize bias in the ongoing study and to assure safe and ethical conduct of the clinical trial, an independent Data Monitoring Committee (DMC), consisting of experts in clinical trials, statistics, and hemophilia, has been convened. The DMC will have sole access during the trial to amalgamated FVIII activity levels, FVIII usage, and bleeding data and The Data Monitoring Committee (DMC) will</u> review available safety and efficacy (eg, FVIII activity) data during the study on an ongoing basis; <del>they and</del> may determine, based on emerging data and the risk/benefit profile, that further enrollment at 6E13 vg/kg should be discontinued in favor of a different dose of BMN 270, not to exceed 6E13 vg/kg. If the DMC recommends a dosing modification, then additional subjects may be enrolled, up to a total of approximately 130 subjects, at the new BMN 270 dose level (regardless of the number of subjects previously enrolled at 6E13 vg/kg).</p> <p><u>An interim analysis is planned after 20 <del>treated</del> <u>evaluable HIV-negative</u> subjects have completed the Week 26 visit. Data will be reviewed by the DMC, based on the statistical analysis plan, and a formal recommendation will be made whether to continue the study as designed.</u></p> <p>The final analysis for the study will be performed after all subjects have been followed for 52 weeks post-BMN 270 infusion. After the final analysis, safety and efficacy will then continue to be assessed long-term in all subjects for a total of approximately 5 years.</p> <p>To avoid breakthrough bleeding, subjects will only discontinue exogenous prophylactic FVIII replacement therapy <u>after FVIII activity has reached at least 5 IU/dL or 4 weeks following infusion of BMN 270, whichever is earlier.</u> Four</p> | 1, 8, 9, 11 |





| Section No./Title         | Revision   | Rationale |
|---------------------------|--|-----------|
|                           | <p>weeks represents the time by which endogenous production of FVIII following gene transfer is expected to be efficacious, based on earlier results.</p> <p><del>Throughout the study, subjects with FVIII activity below 5 IU/dL may be monitored more frequently at the discretion of the Medical Monitor and the Investigator. In subjects who show an initial response to BMN 270 but who later have FVIII activity decline to &lt; 5 IU/dL experience recurring bleeding episodes, the Investigator and Medical Monitor will review the subject's FVIII activity level trends (not specific FVIII activity levels) and discuss whether to resume prior FVIII prophylaxis. In addition,</del></p> <p><del>Subjects who do not respond to BMN 270 treatment (ie, treatment failure, manifesting as either failure to achieve FVIII activity <math>\geq</math> 5 IU/dL by Week 52 or inability to maintain independence from prophylactic FVIII replacement therapy due to joint bleeding episodes, in the judgment of the Investigator) may, at the Investigator's discretion and after discussion with the Medical Monitor, follow an abbreviated visit schedule after Week 52 of the study by attending only the investigator will notify the subject of his FVIII activity levels and will discuss with the subject the risk Q12W and End of bleeding and when (and if) prior FVIII prophylaxis will be resumed. Year visits during Years 2-5.</del></p> <p>There will be an ongoing review of individual subject safety by the Medical Monitor, and both safety and efficacy data by the DMC. FVIII activity by a validated assay will be used to evaluate efficacy over the course of the study.</p> <p>Therapeutic oral corticosteroids may be initiated when a subject's ALT values are elevated or based on review of FVIII activity and liver enzyme data, and subsequent dosage adjustments made, after consultation between the Investigator and the Medical Monitor.</p> |           |
| 2/Synopsis (I/E Criteria) | <p>Patients are eligible to be included in the study only if all of the following criteria apply:</p> <p><del>8. HIV positive patients may be enrolled, only if the patient has a CD4 count <math>&gt;</math> 200/mm<sup>3</sup> and an undetectable viral load (unquantifiable viral load as defined as less than the limit of quantification by the testing laboratory's assay is permitted)</del></p> <p>Patients are excluded from the study if any of the following criteria apply:</p> <p>2. Any evidence of active infection or any immunosuppressive disorder, <del>except for including HIV infection as described in the inclusion criterion above.</del></p> <p>3. Significant liver dysfunction with any of the following abnormal laboratory results:</p> <ul style="list-style-type: none"> <li>• ALT (alanine <del>transaminase</del>) or AST (<del>2x</del>aminotransferase) <math>&gt;</math> 1.25x ULN;</li> <li>• <u>AST (aspartate aminotransferase) <math>&gt;</math> 1.25x ULN;</u></li> <li>• <u>GGT (gamma-glutamyltransferase) <math>&gt;</math> 1.25x ULN</u></li> </ul>   | 1, 3      |



| Section No./Title                    | Revision   | Rationale |
|--------------------------------------|--|-----------|
|                                      | <ul style="list-style-type: none"> <li>• Total bilirubin <del>&gt;2X</del> <u>1.25x</u> ULN;</li> <li>• Alkaline phosphatase <del>&gt;2X</del> <u>1.25x</u> ULN; or</li> <li>• INR (international normalized ratio) <math>\geq 1.4</math>.</li> </ul> <p>Subjects whose liver laboratory assessments fall outside of these ranges may undergo repeat testing of the entire liver test panel within the same Screening window and, if eligibility criteria are met on retest, may be enrolled after confirmation by the Medical Monitor. <del>In addition, subjects with abnormal laboratory results related to confirmed benign liver conditions are considered eligible for the study notwithstanding their abnormal laboratory results and may be enrolled after discussion with the Medical Monitor.</del></p> <p><del>Benign liver conditions are those conditions (eg, Gilbert's syndrome) where physiologic hepatic findings can be considered non-serious in nature and do not confer illness or in most instances require treatment. Individuals with such conditions that do not impact laboratory values such as serum transaminases or conjugated bilirubin (eg, Gilbert's syndrome) and enable assessment of potential liver toxicity following BMN 270 infusion may be included in the study following a review by the Medical Monitor.</del></p> |           |
| 2/Synopsis (Criteria for Evaluation) | <p>Primary efficacy endpoint:</p> <ul style="list-style-type: none"> <li>• Change of the hFVIII activity, as measured by <del>one-stage clotting</del> <u>chromogenic substrate</u> assay, during Weeks 49-52 post-BMN 270 infusion from baseline. Each subject's hFVIII activity during Weeks 49-52 is defined as the median of the values obtained during this 4-week window. Values for hFVIII activity will be excluded if obtained within 72 hours since the last infusion of exogenous FVIII protein concentrates.</li> </ul> <p><u>Safety:</u></p> <ul style="list-style-type: none"> <li>• Liver <del>function</del> tests (<del>LFTs</del> <u>LTs</u>, including ALT, AST, <u>GGT</u>, total bilirubin, and <del>GGT, LDH, bilirubin,</del> alkaline phosphatase<sub>2</sub>)</li> </ul>  | 8, 11     |
| 2/Synopsis (Stats Methods)           | <p><u>Sample Size</u></p> <p><u>Approximately</u> one hundred and thirty (130) subjects may be dosed in the study. The sample size for this study is based on clinical and statistical considerations in order to provide sufficient data to assess both safety and efficacy of BMN 270.</p> <p>...</p> <p><u>Analysis Population</u></p> <p>The <del>efficacy analysis set will consist of</del> <u>intention-to-treat (ITT) population is defined as</u> all subjects who receive BMN 270 infusion.</p>  | 1, 8      |



| Section No./Title | Revision   | Rationale |
|-------------------|--|-----------|
|                   | <p><del>The safety population is, and the same as modified intention-to-treat (mITT) population is defined as subjects who receive BMN 270 infusion and are HIV-negative. The mITT population will be used for the primary efficacy analysis, and the ITT population will be used for the supportive efficacy analysis set. The ITT population will also be used for the safety analysis.</del></p> <p><u>Analysis</u></p> <p>For the primary efficacy endpoint at Week 52 (ie, the change in the hFVIII activity during Weeks 49-52 post-BMN 270 infusion from baseline, as measured by <del>one-stage clotting</del>chromogenic substrate assay), a one-sample t-test will be used to test the null hypothesis that the change is 0 or less against the alternative hypothesis that the change is greater than 0. Descriptive summaries of the proportions of subjects whose FVIII activity during Weeks 49-52 is greater than or equal to select thresholds, such as 15, 25 and 30 IU/dL, and the confidence intervals of the proportions will also be provided. <del>The FVIII activity as measured by chromogenic assay will be analyzed similarly, as a supportive analysis. The analyses for the primary endpoint will be performed using the efficacy analysis set.</del></p> <p>For the secondary endpoints, the analyses will be performed on 110 subjects in the <del>efficacy analysis set</del>mITT population whose baseline data will be prospectively collected for approximately 6 months in the non-interventional study 270-902 prior to their enrollment in 270-301.</p> <p>...</p> <p>An interim analysis is planned after <del>approximately 20 treated</del>evaluable HIV-negative subjects have completed the Week 26 visit (or have discontinued study participation prior to Week 26). The primary efficacy endpoint for the interim analysis is <del>change in the hFVIII activity, as measured by one-stage clotting assay, during Weeks 23-26 post-BMN 270 infusion from baseline. Each subject's hFVIII activity during Weeks 23-26 is defined as the median of the values obtained during this 4-week window. A 2-sided one-sample t-test will be used to test the null hypothesis that the change is 0 or less against the alternative hypothesis that the change is greater than 0. In addition, subjects' hFVIII activity post-Week 23, defined as the median of the values obtained from Week 23 to the time of last follow-up, will be analyzed similarly as an important sensitivity analysis, utilizing additional data beyond Week 26.</del>involves hFVIII activity, as measured by chromogenic substrate assay, achieved post-BMN 270 infusion, as detailed in the statistical analysis plan (SAP).</p> <p><del>Descriptive summaries of the proportions of subjects whose FVIII activity during Weeks 23-26 and from Week 23 to the time of last follow-up is greater than or equal to select thresholds, such as 15, 25 and 30 IU/dL, and the confidence intervals of the proportions will be provided, respectively. The FVIII activity as measured by chromogenic assay will be analyzed similarly, as a supportive analysis.</del></p> <p><del>The fallback procedure will be used to adjust</del>Adjustment for multiplicity of the interim analysis at Week 26 and the final analysis at Week 52 <del>of</del>will be described in the <del>primary efficacy endpoint</del>SAP (regardless of the interim analysis</p> |           |



| Section No./Title                 | Revision   | Rationale   |
|-----------------------------------|--|-------------|
|                                   | <p>results, the study is planned to continue upon the DMC's recommendation, and the final analysis will be performed at Week 52→). At the final analysis at Week 52, the secondary efficacy endpoints will be tested hierarchically.</p> <p><u>Details of the interim analysis, including the control of Type I error rate, will be specified in the SAP.</u></p>  |             |
| 7.4/Overall Risks and Benefits    | <p>The majority of subjects in the ongoing 270-201 clinical study who have received 4E13 or 6E13 vg/kg doses of BMN 270 have had Grade 1 asymptomatic elevations in ALT. For most subjects, the elevations have reached only slightly above the ULN. Based on the effectiveness of transient oral corticosteroid used to suppress a presumed cytotoxic T-cell response in prior studies with hepatic transduction with AAV vectors (Mingozzi, 2013), subjects were treated with 7-32 weeks of oral corticosteroids preventatively or in response to the elevations in ALT to ensure preservation of the transduced hepatocytes. Using this approach, no sustained loss of FVIII activity has been observed in subjects with ALT elevations, consistent with maintaining a high level of hepatocyte function. Moreover, the rise in ALT levels were not accompanied by significant or lasting aberrations in other liver <del>function</del>-tests such as AST, bilirubin or albumin, indicating that extent of toxicity is limited. <u>There has been one HIV-positive subject in the ongoing 270-302 clinical study who experienced Grade 3 asymptomatic elevations in ALT and AST, which has been attributed to an interaction between one or more of his antiretroviral therapy medications and/or unsuspected underlying hepatic disease with BMN 270. In addition, there has been one subject with Gilbert's syndrome in the ongoing 270-301 clinical study who has experienced Grade 3 asymptomatic elevations in ALT and AST. These cases have led to the exclusion of subsequent HIV-positive subjects and requirement of liver tests at Screening that are &lt;1.25 times the upper limit of the normal range in the ongoing 270-301 and 270-302 clinical studies. Of note, two HIV-positive subjects in 270-301 and one presumed Gilbert's syndrome subject in 270-201 have received BMN 270 without experiencing any elevations in ALT to date. Overall, the literature suggests and clinical experience with BMN 270 thus far suggest that transient elevations in liver enzymes are expected following AAV-based gene therapy for the treatment for hemophilia A or B without any long-term concerns of hepatic injury (Manno, 2006); (Nathwani, 2011); (George, 2016); (Miesbach, 2016); (Pasi, 2017).</u></p> | 1, 2, 3     |
| 8/Study Objectives                | <p>The primary efficacy objective of the study is to:</p> <ul style="list-style-type: none"> <li>Assess the efficacy of BMN 270 defined as FVIII activity, as measured by <del>one-stage clotting</del> <u>chromogenic substrate</u> assay, during Weeks 49-52 following intravenous infusion of BMN 270</li> </ul>  | 8           |
| 9.1/Overall Study Design and Plan | <p>Approximately 130 adult subjects with severe HA will receive a 6E13 vg/kg dose of BMN 270 as a single intravenous infusion. Approximately 20 subjects will enroll in the study with at least 12 months of well-documented high-quality</p>  | 1, 8, 9, 11 |



| Section No./Title | Revision   | Rationale |
|-------------------|--|-----------|
|                   | <p>historical data concerning previous bleeding episodes and exogenous FVIII usage, while approximately 110 subjects will enroll in the study after having completed approximately 6 months' participation in the BioMarin-sponsored non-interventional study 270-902, <u>in which bleeding and FVIII use data prior to gene therapy will be prospectively collected.</u></p> <p><del>The Data Monitoring Committee (DMC)</del><u>In order to minimize bias in the ongoing study and to assure safe and ethical conduct of the clinical trial, an independent Data Monitoring Committee (DMC), consisting of experts in clinical trials, statistics, and hemophilia, has been convened. The DMC will have sole access during the trial to amalgamated FVIII activity levels, FVIII usage, and bleeding data and will review available safety and efficacy (eg, FVIII activity) data during the study on an ongoing basis; they and</u> may determine, based on emerging data and the risk/benefit profile, that further enrollment at 6E13 vg/kg should be discontinued in favor of a different dose of BMN 270, not to exceed 6E13 vg/kg. If the DMC recommends a dosing modification, then additional subjects may be enrolled, up to a total of approximately 130 subjects, at the new BMN 270 dose level (regardless of the number of subjects previously enrolled at 6E13 vg/kg).</p> <p>An interim analysis is planned after 20 treated <u>evaluable HIV-negative</u> subjects have completed the Week 26 visit.</p> <p>The final analysis for the study will be performed after all subjects have been followed for 52 weeks post-BMN 270 infusion. After the final analysis, safety and efficacy will then continue to be assessed long-term in all subjects for a total of approximately 5 years.</p> <p>To avoid breakthrough bleeding, subjects will only discontinue exogenous prophylactic FVIII replacement therapy after <u>FVIII activity has reached at least 5 IU/dL or 4 weeks following infusion of BMN 270, whichever is earlier.</u> Four weeks represents the time by which endogenous production of FVIII following gene transfer is expected to be efficacious, <u>based on earlier results.</u></p> <p><del>Throughout the study, subjects with FVIII</del><u>As the relationship between activity below 5 IU/dL may be monitored more frequently at the discretion</u> <del>assay results of the Medical Monitor and the Investigator. In subjects who show an initial response to BMN 270 but who later have FVIII activity decline</del><u>gene product and bleeding remains to be established, Investigators should strive to &lt; 5 IU/dL minimize bias by avoiding consideration of FVIII activity levels by themselves or subjects in the reporting of bleeding episodes and FVIII usage.</u></p> |           |



| Section No./Title                            | Revision   | Rationale   |
|--|--|-------------|
|  | <p><del>In subjects who experience recurrent bleeding episodes, the Investigator and Medical Monitor will review the subject's FVIII activity level trends (not specific FVIII activity levels) and discuss whether to resume prior FVIII prophylaxis. In addition, the investigator will notify</del></p> <p><u>Subjects who do not respond to BMN 270 treatment (ie, treatment failure, manifesting as either failure to achieve FVIII activity <math>\geq</math> 5 IU/dL by Week 52 or inability to maintain independence from prophylactic FVIII replacement therapy due to joint bleeding episodes, in the judgment of the Investigator) may, at the Investigator's discretion and after discussion with the subject of his FVIII activity levels and will discuss with the subject Medical Monitor, follow an abbreviated visit schedule after Week 52 of the study by attending only the risk of bleeding Q12W and when (and if) prior FVIII prophylaxis will be resumed</u>End of Year visits during Years 2-5.</p> <p>There will be an ongoing review of individual subject safety by the Medical Monitor, and both safety and efficacy data by the DMC. <del>FVIII activity by a validated assay will be used to evaluate efficacy over the course of the study.</del> Therapeutic oral corticosteroids may be initiated when a subject's ALT values are elevated <del>or based on review of FVIII activity and liver enzyme data</del>, and subsequent dosage adjustments made, after consultation between the Investigator and the Medical Monitor. Management of ALT elevations is discussed in more detail in Section 9.7.8.3.</p> |             |
| SOE Tables (Table 9.1.1 through Table 9.1.4) | The SOE tables have been updated to reflect changes to the footnotes and elsewhere in the protocol   | 4, 5, 7, 11 |
| Table 9.1.1 (notes)                          | <p><sup>b</sup> Refer to Table 9.8.8.2.1 for laboratory assessments to be included, and to Table 9.8.8.3.1 for liver tests (LTs). LTs may be monitored more or less frequently (and in particular when ALT values are <math>\geq</math> 1.5x ULN <u>or &gt; ULN &amp; &gt; 2x baseline value</u>) based on discussion between the Medical Monitor and the Investigator and review of subject data, but LTs will be monitored at least twice weekly during periods when a subject's ALT is <math>\geq</math> 3x ULN. Subjects with ALT &gt; 1.5x ULN <u>or &gt; ULN &amp; &gt; 2x baseline value</u> during the study and either an alternative etiology considered or for further evaluation of the lab abnormality may undergo additional evaluations (eg, imaging studies including MRI or ultrasound, additional blood tests, and/or liver biopsy) at the discretion of the Investigator. Additional testing of FVIII and LTs during any study week may be performed if: (1) the ALT has increased to above ULN; (2) Increases in ALT values from prior assessment are accompanied by declines in FVIII activity level; or after a discussion between the Medical Monitor and the Investigator based on a review of subject data. If FVIII levels and/or ALT values are stable</p>  | 10, 11      |



| Section No./Title                   | Revision   | Rationale    |
|-------------------------------------|--|--------------|
|                                     | <p>over the course of several weeks, assessment of FVIII activity and ALT levels may be adjusted based on discussion between the Medical Monitor and the Investigator.</p> <p><sup>m</sup>In case of hypersensitivity or adverse drug reaction, safety assessment, including physical examination and vital signs, will be done and additional blood samples will be collected within 1 hour of the hypersensitivity reaction (eg, tryptase, C3, C3a, C4, C5, <u>C5a</u>, and <del>C5a</del> <u>cytokine bead array</u>, as well as possible additional exploratory testing) and <del>one sample</del> <u>samples for IgE and cytokine bead array</u> (and possible additional exploratory testing) between 8-24 hours after the reaction, if possible. <u>In addition, a blood sample should be taken 1 week after the hypersensitivity reaction for assessment of the cytokine bead array.</u> In-patient observation can be extended and additional blood samples can be collected if deemed necessary at the discretion of the Investigator and Medical Monitor.</p>   |              |
| Table 9.1.2 and Table 9.1.3 (notes) | <p><sup>b</sup> Refer to Table 9.8.8.2.1 for laboratory assessments to be included, and to Table 9.8.8.3.1 for liver tests (LTs). LTs may be monitored more or less frequently (and in particular when ALT values are <math>\geq 1.5x</math> ULN <u>or <math>&gt; ULN</math> &amp; <math>&gt; 2x</math> baseline value</u>) based on discussion between the Medical Monitor and the Investigator and review of subject data, but LTs will be monitored at least twice weekly during periods when a subject's ALT is <math>\geq 3x</math> ULN. Subjects with ALT <math>&gt; 1.5x</math> ULN <u>or <math>&gt; ULN</math> &amp; <math>&gt; 2x</math> baseline value</u> during the study and either an alternative etiology considered or for further evaluation of the lab abnormality may undergo additional evaluations (eg, imaging studies including MRI or ultrasound, additional blood tests, and/or liver biopsy) at the discretion of the Investigator. Additional testing of FVIII and LTs during any study week may be performed if: (1) the ALT has increased to above ULN; (2) Increases in ALT values from prior assessment are accompanied by declines in FVIII activity level; or after a discussion between the Medical Monitor and the Investigator based on a review of subject data. If FVIII levels and/or ALT values are stable over the course of several weeks, assessment of FVIII activity and ALT levels may be adjusted based on discussion between the Medical Monitor and the Investigator.</p> | 10, 11       |
| Table 9.1.4/9.1.5 (and notes)       | Table 9.1.4 has been split into 2 tables – Table 9.1.4 now includes Weeks 33-52, and Table 9.1.5 includes visits during Years 2-5. Notes to both tables reflect these changes.   | 5, 6, 10, 11 |
| Table 9.1.6 (notes)                 | <p><sup>b</sup> Following initiation or completion of steroid regimen, if a recurrence of ALT values <math>\geq 1.5x</math> ULN <u>or <math>&gt; ULN</math> &amp; <math>&gt; 2x</math> baseline value</u> is reported, steroid management decisions will based on discussions between the Investigator and Medical Monitor. Modification of the steroid regimen may take into consideration possible confounders for the ALT elevation, relationship between increases in ALT and FVIII activity, ALT/FVIII levels post steroid initiation, and</p>  | 10           |





| Section No./Title        | Revision  | Rationale   |
|--------------------------|---|-------------|
|                          | adverse events related to steroid dosing. Guidance for tapering oral corticosteroid dosing can be found in Section 9.4.8.2.   |             |
| 9.3.1/Inclusion Criteria | <p>Individuals eligible to participate in this study must meet all of the following inclusion criteria:</p> <p><del>8. HIV positive patients may be enrolled, only if the patient has a CD4 count &gt; 200/mm<sup>3</sup> and an undetectable viral load (unquantifiable viral load as defined as less than the limit of quantification by the testing laboratory's assay is permitted)</del></p>   | 1, 3        |
| 9.3.2/Exclusion Criteria | <p>Individuals who meet any of the following exclusion criteria will not be eligible to participate in the study:</p> <p>2. Any evidence of active infection or any immunosuppressive disorder, <del>except for</del> <u>including</u> HIV infection <del>as described in the inclusion criterion above.</del></p> <p>3. Significant liver dysfunction with any of the following abnormal laboratory results:</p> <ul style="list-style-type: none"> <li>• ALT (alanine <del>transaminase</del>) or AST <del>&gt;2x</del> <u>aminotransferase</u> &gt; 1.25x ULN;</li> <li>• <u>AST (aspartate aminotransferase) &gt; 1.25x ULN;</u></li> <li>• <u>GGT (gamma-glutamyltransferase) &gt; 1.25x ULN</u></li> <li>• Total bilirubin <del>&gt;2x</del> <u>1.25x</u> ULN;</li> <li>• Alkaline phosphatase <del>&gt;2x</del> <u>1.25x</u> ULN; or</li> <li>• INR (international normalized ratio) ≥ 1.4.</li> </ul> <p>Subjects whose liver laboratory assessments fall outside of these ranges may undergo repeat testing <u>of the entire liver test panel within the same Screening window</u> and, if eligibility criteria are met on retest, may be enrolled after confirmation by the Medical Monitor. <del>In addition, subjects with abnormal laboratory results related to confirmed benign liver conditions are considered eligible for the study notwithstanding their abnormal laboratory results and may be enrolled after discussion with the Medical Monitor.</del></p> <p><del>Benign liver conditions are those conditions (eg, Gilbert's syndrome) where physiologic hepatic findings can be considered non-serious in nature and do not confer illness or in most instances require treatment. Individuals with such conditions that do not impact laboratory values such as serum transaminases or conjugated bilirubin (eg, Gilbert's syndrome) and enable assessment of potential liver toxicity following BMN 270 infusion may be included in the study following a review by the Medical Monitor.</del></p> | 1, 3, 8, 11 |





| Section No./Title                        | Revision  | Rationale |
|--|---|-----------|
| 9.4.4/Directions for Administration      | In case of hypersensitivity or adverse drug reaction, safety assessment, including physical examination and vital signs, will be done and additional blood samples will be collected within 1 hour of the hypersensitivity reaction (eg, tryptase, C3, C3a, C4, C5, <u>C5a</u> , and <del>C5a</del> <u>cytokine bead array</u> , as well as possible additional exploratory testing) and <del>one sample</del> <u>samples for IgE and cytokine bead array</u> (and possible additional exploratory testing) between 8-24 hours after the reaction, if possible. <u>In addition, a blood sample should be taken 1 week after the hypersensitivity reaction for assessment of the cytokine bead array.</u> In-patient observation can be extended and additional blood samples can be collected if deemed necessary at the discretion of the Investigator and Medical Monitor.  | 11        |
| 9.4.8/Prior and Concomitant Medications  | The following medications are prohibited starting 30 days before Screening and through the end of the study, and the Sponsor must be notified if a subject receives any of these during the study: <ul style="list-style-type: none"> <li>• <u>Efavirenz</u></li> <li>• <u>Lamivudine</u></li> </ul>  | 2         |
| 9.4.8.1/Concomitant Hemophilia Treatment | Subjects on prophylactic FVIII therapy will discontinue their regular treatment regimen starting 4 weeks after the day of infusion <del>or after FVIII activity has reached at least 5 IU/dL (whichever is earlier)</del> and switch to an “on-demand” schedule. FVIII replacement therapy can always be taken as needed by the subject for treatment of an acute bleeding episode; the subject must carefully record his treatment and bleeding episodes in his diary.   | 9         |
| 9.4.8.2/Therapeutic Corticosteroids      | Therapeutic oral corticosteroids (prednisone or converted equivalent) should be initiated when either of the following occurs post-BMN 270 infusion in any subject and after consultation with the Medical Monitor (or their designee): <ul style="list-style-type: none"> <li>• <u>ALT <math>\geq</math> 1.5x ULN or ALT <math>&gt;</math> ULN &amp; <math>&gt;</math> 2x baseline value</u> in 2 consecutive assessments within 72 hours and alternative etiologies have been ruled out, or ALT <math>\geq</math> 3x ULN in 2 consecutive assessments within 48 hours (refer to Table 9.8.8.3.2)</li> </ul> <del>In addition, if FVIII activity drops <math>&gt;</math> 50% at any time post-BMN 270 infusion, a course of therapeutic oral corticosteroids should be considered upon consultation between the Investigator and the Medical Monitor.</del> <p>Following initiation or completion of therapeutic oral corticosteroids, if ALT elevation <u><math>\geq</math> 1.5x ULN or ALT <math>\geq</math> ULN &amp; <math>\geq</math> 2x baseline value</u> is reported, corticosteroid management decisions will be based on discussions between the Investigator and Medical Monitor.</p> | 9, 10     |



| Section No./Title   | Revision   | Rationale |
|---|--|-----------|
| Table 9.4.8.2.1/<br>Adjustments to<br>Corticosteroid<br>Regimen | Table 9.4.8.2.1 has been updated to reflect changes made in this amendment.  | 10        |
| 9.4.8.3/Monitoring<br>HIV Subjects                              | <p><del>HIV positive subjects may be enrolled in 270-301 if the subject has a CD4 count &gt; 200/mm<sup>3</sup> and an undetectable viral load (unquantifiable viral load as defined as less than the limit of quantification by the testing laboratory's assay is permitted).</del></p> <p><u>Subjects HIV-positive subjects who have previously enrolled in 270-301 should continue anti-retroviral therapy (ART) as prescribed and follow routine monitoring of CD4 count and viral load (US Dept Health Human Services, 2014). No alterations in the monitoring are indicated for enrolled immunocompetent HIV-positive subjects who receive corticosteroids as part of their enrollment in 270-301.</u></p>   | 1         |
| 9.7/Dietary or Other<br>Protocol Restrictions                   | Subjects should be advised to abstain from any blood or sperm donation after BMN 270 infusion, until there is no further evidence of vector shedding <u>from PCR analysis of samples.</u>  | 11        |
| 9.8.2.1/FVIII Activity  | <p>The primary efficacy variable is change of the hFVIII activity, as measured by <del>one-stage clotting</del><u>chromogenic substrate</u> assay, during Weeks 49-52 post-BMN 270 infusion from baseline.</p> <p>...</p> <p><del>In subjects who show an initial response to BMN 270 but who later have FVIII activity decline to &lt; 5 IU/dL, the investigator and Medical Monitor will review the subject's FVIII activity level trends (not specific FVIII activity levels) and discuss whether to resume prior FVIII prophylaxis. In addition, the investigator will notify the subject of his FVIII activity levels and will discuss with the subject the risk of bleeding and when (and if) prior FVIII prophylaxis will be resumed.</del></p> <p>...</p> <p><u>Subjects who do not respond to BMN 270 treatment (ie treatment failure, manifesting as either failure to achieve FVIII activity <math>\geq</math> 5 IU/dL by Week 52 or inability to maintain independence from prophylactic FVIII replacement therapy due to joint bleeding episodes, in the judgment of the Investigator) may, at the Investigator's discretion and after discussion with the Medical Monitor, follow an abbreviated visit schedule after Week 52 of the study by attending only the Q12W and End of Year visits during Years 2-5.</u></p> | 8, 9      |



| Section No./Title                                    | Revision   | Rationale |
|--|--|-----------|
| 9.8.3.1/FVIII Replacement Therapy/ Bleeding Episodes | <u>In subjects who experience recurrent bleeding episodes, the Investigator and Medical Monitor will discuss whether to resume prior FVIII prophylaxis.</u>  | 9         |
| 9.8.8.2/Clinical Laboratory Assessments              | <p>In case of hypersensitivity or adverse drug reaction, safety assessment, including physical examination and vital signs, will be done and additional blood samples will be collected within 1 hour of the hypersensitivity reaction (eg, tryptase, C3, C3a, C4, C5, <u>C5a</u>, and <del>C5a</del> <u>cytokine bead array</u>, as well as possible additional exploratory testing) and <del>one sample</del> <u>samples for IgE and cytokine bead array</u> (and possible additional exploratory testing) between 8-24 hours after the reaction. <u>In addition, a blood sample should be taken 1 week after the hypersensitivity reaction for assessment of the cytokine bead array.</u></p> <p>During Years 2-5, at applicable sites, certain study assessments may be performed by a mobile nursing (MN) professional at the patient's home or another suitable location, such as their school or office, to improve access and convenience for patients participating in the study. The Sponsor may select a healthcare company that will be responsible for providing MN services for participating sites (the MN vendor). The MN vendor is responsible for ensuring that all MN professionals are licensed, qualified, and in good standing, as per applicable regulations, and that appropriate background checks have been performed. If the investigator at a participating site determines that MN services are appropriate for a patient and the patient gives written informed consent to participate in MN visits, the MN network will communicate with the patient and the patient's site. MN visits will be allowed for the Q4W (during Year 2) and Q6W (during Years 3-5) visits; the <del>Q3M</del> <u>Q12W visits and End of Year</u> visits during Years 2-5 will not be performed by an MN professional but will be done at the study site.</p> | 5, 11     |
| 9.8.8.3/Liver Function and Hepatitis Testing         | Evidence of ongoing hepatitis B or hepatitis C infection is exclusionary. Subjects with a history of hepatitis B or hepatitis C infection prior to study entry will be tested for hepatitis B and hepatitis C reactivation at Week 16. <u>Subjects with a history of hepatitis B or hepatitis C will be asked for information about the treatments received as part of their medical history assessment at Screening.</u>  | 7         |
| Table 9.8.8.3.2/ Evaluation of ALT Elevations        | <u>If ALT is &gt; ULN &amp; &gt; 2x baseline in 2 consecutive assessments within 72 hours and alternative etiologies have been ruled out, start oral corticosteroids upon consultation with the Medical Monitor (refer to Section 9.4.8.2)</u>   | 10        |



| Section No./Title  | Revision  | Rationale |
|--|---|-----------|
| Table 9.8.8.3.3 (Viral and Autoimmune Hepatitis Testing)     | Hepatitis E has been added to this table  | 11        |
| 9.8.8.5/Vitals, Physical Exam, and Other Safety Observations | Height will be recorded at Screening only. Weight will be recorded at Screening and then every 4 weeks thereafter through Week 52, and <del>every 6 months</del> <u>at the second Q12W visit each year and at every End of Year visit</u> during Years 2-5.   | 5         |
| 9.8.8.6/Vector Shedding                                      | <p>Vector shedding will also be extensively studied in the present clinical trial, at the time points indicated in Table 9.1.1, Table 9.1.2, Table 9.1.3, Table 9.1.4, and Table 9.1.5. Testing will continue until at least 3 consecutive negative results are obtained. Testing of semen will continue at least through Week 12, even if 3 consecutive negative results have been recorded in that compartment prior to that time point. Subjects who have not had 3 consecutive negative semen samples by Week 52 should continue to have PCR testing in semen every 4 weeks (during Year 2) and every 6 weeks (during Years 3-5) until 3 consecutive negative samples are documented (or upon consultation between the Investigator and Medical Monitor). <u>Subjects who meet the definition of treatment failure and wish to follow an abbreviated schedule (refer to Section 12.7) but who have not cleared vector shedding from all fluids must still provide samples for assessment every 4 weeks (during Year 2) or every 6 weeks (during Years 3-5) until vector shedding has cleared. Such subjects may provide samples on the designated study visit dates either at the sites or through use of a MN professional.</u> Samples may be fractionated prior to shedding analysis in order to better characterize the presence, structure, and location of vector DNA and/or vector capsid within each matrix. If needed, the fractionation may be performed with samples collected specifically for shedding analysis (saliva, blood, semen, urine, feces). Alternatively, the vector DNA characterization during shedding analysis may utilize already fractionated exploratory samples obtained from the above biofluids, such as exploratory plasma samples, exploratory PBMC samples, and red blood cells recovered during PBMC/plasma isolations.</p> <p>...</p> <p>Contraception use may need to be extended beyond 26 weeks in individual subjects based on observed vector shedding in semen. After 26 weeks, subjects may stop contraception use only if they have had 3 consecutive negative semen samples. <u>(upon consultation between the Investigator and Medical Monitor).</u></p> | 6, 11     |



| Section No./Title                 | Revision   | Rationale |
|-----------------------------------|--|-----------|
| 10.2.1/EOSI                       | <p>The following EOSI need to be reported to the Sponsor within 24 hours of site awareness, irrespective of seriousness, severity or causality:</p> <ul style="list-style-type: none"> <li>Elevation of ALT <math>\geq 1.5x</math> ULN <u>or</u> ALT <math>&gt; ULN</math> &amp; <math>&gt; 2x</math> baseline value, regardless of whether that elevation triggers an initiation or modification of oral corticosteroid treatment</li> </ul>  | 10        |
| 12.1/Screening Visit              | <p>The following procedures will be performed during the Screening Period:</p> <ul style="list-style-type: none"> <li>Full medical history, including hemophilia A history, Hepatitis B, Hepatitis C, and HIV. <u>Subjects with a history of hepatitis B or hepatitis C will be asked for information about the treatments received. Any prior pharmacokinetics information obtained while the subject was receiving prophylactic or on-demand FVIII therapy prior to the study should also be collected.</u></li> </ul>   | 7         |
| 12.4/Treatment Visit              | <p>In case of hypersensitivity or adverse drug reaction, safety assessment, including physical examination and vital signs, will be done and additional blood samples will be collected within 1 hour of the hypersensitivity reaction (eg, tryptase, C3, C3a, C4, C5, <u>C5a, and C5a cytokine bead array</u>, as well as possible additional exploratory testing) and <del>one sample</del> <u>samples for IgE and cytokine bead array (and possible additional exploratory testing) between 8-24 hours after the reaction, if possible. In addition, a blood sample should be taken 1 week after the hypersensitivity reaction for assessment of the cytokine bead array.</u> In-patient observation can be extended and additional blood samples can be collected if deemed necessary at the discretion of the Investigator and Medical Monitor.</p> | 11        |
| 12.5.1/Weeks 1-26, Once Per Week  | <p>The following procedures will be performed at one visit per week from Weeks 1 through 26:</p> <ul style="list-style-type: none"> <li>Liver Tests (refer to Table 9.8.8.3.1) <ul style="list-style-type: none"> <li>LTs may be monitored more or less frequently (and in particular when ALT values are <math>\geq 1.5x</math> ULN <u>or</u> <math>&gt; ULN</math> &amp; <math>&gt; 2x</math> baseline value) based on discussion between the Medical Monitor and the Investigator and review of subject data, but LTs will be monitored at least twice weekly during periods when a subject's ALT is <math>\geq 3x</math> ULN.</li> </ul> </li> </ul>   | 10        |
| 12.6.1/Weeks 27-52, Once Per Week | <p>At every visit (Weeks 27-36, 38, 40, 42, 44, 46, 48, 50, and 52), the following procedures will be performed:</p> <ul style="list-style-type: none"> <li>Liver Tests (refer to Table 9.8.8.3.1)</li> </ul>  | 10        |



| Section No./Title  | Revision   | Rationale |
|--|--|-----------|
|  | <ul style="list-style-type: none"> <li>○ LTs may be monitored more or less frequently (and in particular when ALT values are <math>\geq 1.5x</math> ULN <u>or</u> <math>&gt; ULN \ \&amp; \ &gt; 2x</math> baseline value) based on discussion between the Medical Monitor and the Investigator and review of subject data, but LTs will be monitored at least twice weekly during periods when a subject's ALT is <math>\geq 3x</math> ULN.</li> </ul>  |           |
| 12.7/Years 2-5   | <p>During Years 2-5, at applicable sites, certain study assessments may be performed by a mobile nursing (MN) professional at the patient's home or another suitable location, such as their school or office, to improve access and convenience for patients participating in the study. The Sponsor may select a healthcare company that will be responsible for providing MN services for participating sites (the MN vendor). The MN vendor is responsible for ensuring that all MN professionals are licensed, qualified, and in good standing, as per applicable regulations, and that appropriate background checks have been performed. If the investigator at a participating site determines that MN services are appropriate for a patient and the patient gives written informed consent to participate in MN visits, the MN network will communicate with the patient and the patient's site. MN visits will be allowed for the Q4W (during Year 2) and Q6W (during Years 3-5) visits; the <del>Q3M</del> Q12W visits and End of Year visits during Years 2-5 will not be performed by an MN professional but will be done at the study site.</p> <p><u>Subjects who do not respond to BMN 270 treatment (ie, treatment failure, manifesting as either failure to achieve FVIII activity <math>\geq 5</math> IU/dL by Week 52 or inability to maintain independence from prophylactic FVIII replacement therapy due to joint bleeding episodes, in the judgment of the Investigator) may, at the Investigator's discretion and after discussion with the Medical Monitor, follow an abbreviated visit schedule after Week 52 of the study by attending only the Q12W and End of Year visits during Years 2-5.</u></p> <p><u>Subjects who meet the definition of treatment failure and wish to follow an abbreviated schedule but who have not cleared vector shedding from all fluids must still provide samples for assessment every 4 weeks (during Year 2) or every 6 weeks (during Years 3-5) until vector shedding has cleared. Such subjects may provide samples on the designated study visit dates either at the sites or through use of a MN professional.</u></p> | 5, 6, 11  |
| 12.7.1/Year 2 – Every 4 Weeks (not required for treatment failure) | <p>During Year 2, every 4 weeks (<del><math>\pm 2</math> weeks, or as scheduled to align with visits for performing assessments to be done every 3 months [Section ]</del>), (<math>\pm 2</math> weeks), the following procedures will be performed:</p> <ul style="list-style-type: none"> <li>• Liver Tests (refer to Table 9.8.8.3.1)</li> </ul>  | 5, 6, 10  |



| Section No./Title  | Revision   | Rationale |
|--|--|-----------|
|  | <ul style="list-style-type: none"> <li>○ LTs may be monitored more or less frequently (and in particular when ALT values are <math>\geq 1.5x</math> ULN <u>or</u> <math>&gt; ULN \ \&amp; \ &gt; 2x</math> baseline value) based on discussion between the Medical Monitor and the Investigator and review of subject data, but LTs will be monitored at least twice weekly during periods when a subject's ALT is <math>\geq 3x</math> ULN.</li> <li>● PCR of vector DNA in blood, saliva, urine, semen, and stools (if required) <ul style="list-style-type: none"> <li>○ Sample testing during Year 2 is not required if at least 3 consecutive samples are negative during the Post-Infusion Follow-Up period in Weeks 1-52. Subjects who have not had 3 consecutive negative semen samples by Week 52 should continue to have PCR testing of semen every 4 weeks during Years 2 until 3 consecutive negative samples are documented (or upon consultation between the Investigator and Medical Monitor).</li> <li>○ <u>Subjects who meet the definition of treatment failure and wish to follow an abbreviated schedule but who have not cleared vector shedding from all fluids must still provide samples for assessment every 4 weeks during Year 2 until vector shedding has cleared. Such subjects may provide samples on the designated study visit dates either at the sites or through use of a MN professional.</u></li> </ul> </li> </ul> |           |
| 12.7.2/Years 3-5 – Every 6 Weeks ( <u>not required for treatment failure</u> ) | <p>During Years 3-5, every 6 weeks (<math>\pm 2</math> weeks), the following procedures will be performed:</p> <ul style="list-style-type: none"> <li>● Liver Tests (refer to Table 9.8.8.3.1) <ul style="list-style-type: none"> <li>○ LTs may be monitored more or less frequently (and in particular when ALT values are <math>\geq 1.5x</math> ULN <u>or</u> <math>&gt; ULN \ \&amp; \ &gt; 2x</math> baseline value) based on discussion between the Medical Monitor and the Investigator and review of subject data, but LTs will be monitored at least twice weekly during periods when a subject's ALT is <math>\geq 3x</math> ULN.</li> </ul> </li> <li>● PCR of vector DNA in blood, saliva, urine, semen, and stools (if required) <ul style="list-style-type: none"> <li>○ Sample testing during Years 3-5 is not required if at least 3 consecutive samples are clear by the end of Year 2. Subjects who have not had 3 consecutive negative semen samples by the end of Year 2 should continue to have PCR testing of semen every 6 weeks during Years 3-5 until 3 consecutive negative samples are documented (or upon consultation between the Investigator and Medical Monitor).</li> </ul> </li> </ul>   | 6, 10     |



| Section No./Title  | Revision  | Rationale |
|--|---|-----------|
|  | <ul style="list-style-type: none"> <li>○ <u>Subjects who meet the definition of treatment failure and wish to follow an abbreviated schedule but who have not cleared vector shedding from all fluids must still provide samples for assessment every 6 weeks during Years 3-5 until vector shedding has cleared. Such subjects may provide samples on the designated study visit dates either at the sites or through use of a MN professional.</u></li> </ul>   |           |
| <p>12.7.3: Years 2-5 – <del>Every 3 Months</del> <u>Every 12 Weeks and End of Years Visits (required for all subjects)</u></p> | <p><del>Every</del> <u>During Years 2-5, subjects will be asked to return to the study site for visits at the following study weeks (<math>\pm 2</math> weeks):</u></p> <ul style="list-style-type: none"> <li>• <u>Year 2 – Week 64, Week 76, Week 88, Week 104</u></li> <li>• <u>Year 3 months (<math>\pm 2</math> weeks), – Week 116, Week 128, Week 140, Week 156</u></li> <li>• <u>Year 4 – Week 168, Week 180, Week 192, Week 208</u></li> <li>• <u>Year 5 – Week 220, Week 232, Week 244, Week 260</u></li> </ul> <p><u>For each of these years, the last study visit listed (Week 104, Week 156, Week 208, and Week 260) will serve as an End of Year visit. The every 12 week and End of Year visits may not be performed remotely by MN services.</u></p> <p><u>At the every 12 week and End of Year visits, the following procedures will be performed:</u></p> <ul style="list-style-type: none"> <li>• Physical examination <ul style="list-style-type: none"> <li>○ <del>Complete physical examination will be performed every 52 weeks</del> <u>at the End of Year visits; brief physical examination may be performed at other visits.</u></li> </ul> </li> <li>• <u>Weight (at Week 76, Week 128, Week 180, Week 232, and End of Year visits only)</u></li> <li>• Liver Tests (refer to Table 9.8.8.3.1) <ul style="list-style-type: none"> <li>○ <u>LTs may be monitored more or less frequently (and in particular when ALT values are <math>\geq 1.5x</math> ULN or <math>&gt; ULN</math> &amp; <math>&gt; 2x</math> baseline value) based on discussion between the Medical Monitor and the Investigator and review of subject data, but LTs will be monitored at least twice weekly during periods when a subject's ALT is <math>\geq 3x</math> ULN.</u></li> </ul> </li> <li>• <u>Blood chemistry, hematology, and coagulation tests (refer to Table 9.7.8.2.1) (at Week 76, Week 128, Week 180, Week 232, and End of Year visits only)</u></li> </ul> | 5, 10, 11 |





| Section No./Title                              | Revision  | Rationale |
|--|---|-----------|
|  | <ul style="list-style-type: none"> <li>• <u>Urine Tests (refer to Table 9.7.8.2.1) (at Week 76, Week 128, Week 180, Week 232, and End of Year visits only)</u></li> <li>• <u>Haemo-QoL-A assessment (at Week 76, Week 128, Week 180, Week 232, and End of Year visits only)</u></li> <li>• <u>EQ-5D-5L (at Week 76, Week 128, Week 180, Week 232, and End of Year visits only)</u></li> <li>• <u>HAL (at Week 76, Week 128, Week 180, Week 232, and End of Year visits only)</u></li> <li>• <u>WPAI+CIQ:HS (at Week 76, Week 128, Week 180, Week 232, and End of Year visits only)</u></li> <li>• <u>PROBE (at Week 76, Week 128, Week 180, Week 232, and End of Year visits only)</u></li> </ul>                               |           |
| <del>12.7.4/Years 2-5<br/>Every 6 months</del> | <p>Every six months starting at the <del>Week 78</del> visit (ie, <del>26</del> weeks after the <del>Week 52</del> visit at the end of Year 1 of the Long-Term Follow-up period), the following procedures will be performed:</p> <ul style="list-style-type: none"> <li>• <del>Weight</del></li> <li>• <del>Blood chemistry, hematology, and coagulation tests (refer to )</del></li> <li>• <del>Urine Tests (refer to )</del></li> <li>• <del>Haemo-QoL-A assessment</del></li> <li>• <del>EQ-5D-5L</del></li> <li>• <del>HAL</del></li> <li>• <del>WPAI+CIQ:HS</del></li> <li>• <del>PROBE</del></li> </ul>  | 5         |
| 14.1.1/Interim Analysis                        | <p>An interim analysis is planned after <del>20 treated</del> approximately 20 evaluable HIV-negative subjects have completed the Week 26 visit (or have discontinued study participation prior to Week 26). <u>Data will be reviewed by the DMC, based on the SAP, and a formal recommendation will be made whether to continue the study as designed.</u></p> <p><u>The primary efficacy endpoint for the interim analysis is change in the hFVIII activity, as measured by one-stage clotting assay, during Weeks 23-26 post-BMN 270 infusion from baseline. Each subject's hFVIII activity during Weeks 23-26 is defined as the median of the values obtained during this 4-week window. Values for hFVIII activity</u></p> | 1, 8, 11  |



| Section No./Title              | Revision   | Rationale |
|--------------------------------|--|-----------|
|                                | <p><del>will be excluded if obtained within 72 hours since the last infusion of exogenous FVIII protein concentrates. A 2-sided one-sample t test will be used to test the null hypothesis that the change is 0. In addition, subjects' hFVIII activity post-Week 23, defined as the median of the values obtained from Week 23 to the time of last follow-up, will be analyzed similarly as an important sensitivity analysis, utilizing additional data beyond Week 26. Descriptive summaries of the proportions of subjects whose FVIII activity during Weeks 23-26 and from Week 23 to the time of last follow up is greater than or equal to select thresholds, such as 15, 25 and 30 IU/dL, and the confidence intervals of the proportions will be provided, respectively. The FVIII activity as measured by chromogenic assay will be analyzed similarly, as a supportive analysis.</del></p> <p><u>The primary efficacy endpoint for the interim analysis involves hFVIII activity, as measured by chromogenic substrate assay, achieved post-BMN 270 infusion.</u></p> <p>The fallback procedure (Wiens, 2005) will be used to adjust for multiplicity of the interim analysis at Week 26 and the final analysis at Week 52 <del>of the primary efficacy endpoint.</del> (regardless of the interim analysis results, the study is planned to continue upon the DMC's recommendation, and the final analysis will be performed at Week 52). At the final analysis at Week 52, the secondary efficacy endpoints will be tested hierarchically; the level of significance will be determined by the fallback procedure.</p> <p>The secondary and tertiary endpoints will be summarized descriptively at the interim (Week 26) analysis.</p> <p>The details of the interim analysis, including the control of Type I error rate, will be specified in <del>an interim analysis plan</del> <u>the SAP.</u></p> |           |
| 14.2/Primary Efficacy Endpoint | <p>For the primary efficacy endpoint at Week 52 (ie, the change in the hFVIII activity during Weeks 49-52 post-BMN 270 infusion from baseline, as measured by <del>one-stage clotting</del> <u>chromogenic substrate</u> assay), a one-sample t-test will be used to test the null hypothesis that the change is 0 or less against the alternative hypothesis that the change is greater than 0. Descriptive summaries of the proportions of subjects whose FVIII activity during Weeks 49-52 is greater than or equal to select thresholds, such as 15, 25 and 30 IU/dL, and the confidence intervals of the proportions will also be provided. <del>The FVIII activity as measured by chromogenic assay will be analyzed similarly, as a supportive analysis.</del></p> <p>The analyses for the primary endpoint will be performed using the <del>efficacy analysis</del> <u>selected populations</u> as defined in Section 14.8.</p>  | 8         |



| Section No./Title                 | Revision   | Rationale |
|-----------------------------------|--|-----------|
| 14.3/Secondary Efficacy Endpoint  | The primary analyses for the secondary endpoints will be performed on the 110 subjects in the <del>efficacy analysis set</del> <u>ITT population</u> who will be followed up for approximately 6 months in the non-interventional study 270-902 prior to their enrollment in 270-301. The baseline values will be derived from the prospectively collected data in 270-902.  | 8         |
| 14.7/Determination of Sample Size | <u>Approximately one hundred and thirty (130) subjects</u> may be dosed in the study. The sample size for this study is based on clinical and statistical considerations in order to provide sufficient data to assess both safety and efficacy of BMN 270.  | 8         |
| 14.8/Analysis Populations         | <p>The <del>efficacy analysis set will consist of</del> <u>intention-to-treat (ITT) population is defined as all subjects who receive the BMN 270 infusion.</u></p> <p><del>The safety population is,</del> <u>and the modified intention-to-treat (mITT) population is defined as subjects who receive BMN 270 infusion and are HIV-negative. The mITT population will be used for the same as primary efficacy analysis and ITT will be used for the supportive efficacy analysis set. The ITT population will also be used for the safety analysis.</u></p> | 8         |

# BOMARIN®

## CLINICAL STUDY PROTOCOL

|   |   |
|---|---|
| <b>Study Title:</b>   | A Phase 3 Open-Label, Single-Arm Study To Evaluate The Efficacy and Safety of BMN 270, an Adeno-Associated Virus Vector-Mediated Gene Transfer of Human Factor VIII in Hemophilia A Patients with Residual FVIII Levels $\leq$ 1 IU/dL Receiving Prophylactic FVIII Infusions |
| <b>Protocol Number:</b>   | 270-301   |
| <b>Active Investigational Product:</b>  | AAV5-hFVIII-SQ  |
| <b>IND/European Union Drug Regulating Authorities Clinical Trials (EudraCT) Number:</b> | 2017-003215-19<br>IND #: 017659   |
| <b>Indication:</b>  | Hemophilia A  |
| <b>Sponsor:</b>   | BioMarin Pharmaceutical Inc.<br>105 Digital Drive<br>Novato, CA 94949   |
| <b>Development Phase:</b>   | Phase 3   |
| <b>Sponsor's Responsible Medical Monitor:</b>   | PI [REDACTED] MD, MPhil<br>PI [REDACTED]<br>BioMarin Pharmaceutical Inc.<br>105 Digital Drive<br>Novato, CA 94949   |
| <b>Duration of Subject Participation:</b>   | Approximately 264 weeks   |
| <b>Dose:</b>  | 6E13 vg/kg  |
| <b>Study Population:</b>  | Males aged 18 or older  |
| <b>Date of Original Protocol:</b>   | 14 August 2017  |
| <b>Date of Amendment 1 (United States Specific):</b>                                    | 2 October 2017  |
| <b>Date of Amendment 1 (Global)</b>   | 25 January 2018   |
| <b>Date of Amendment 2 (Global)</b>   | 28 June 2018  |
| <b>Date of Amendment 3 (Global)</b>   | 24 August 2018  |
| <b>Date of Amendment 4 (Global)</b>   | 9 November 2018   |

Property of BioMarin

**CONFIDENTIAL**

May not be divulged, published, or otherwise disclosed to others without prior written approval from BioMarin.

This study will be conducted according to the principles of Good Clinical Practice as described in the U.S. Code of Federal Regulations and the International Conference on Harmonisation Guidelines, including the archiving of essential documents



---

## CLINICAL STUDY PROTOCOL AMENDMENT SUMMARY

### Amendment 4

**Date: 9 November 2018**

---

### RATIONALE AND SUMMARY OF CHANGES

A summary of major changes covered by Amendment 4 to the 270-301 protocol is provided below:

1. Some visits during Year 1 of the study have been designated as optional mobile nursing or lab draw-only visits for subjects who are enrolling in 270-301 following participation in 270-902.

**Rationale:** The number of full study visits at the site through Week 52 creates high subject and site staff burden, in terms of frequent travel to and lengthy time spent at the site by subjects and assessments deemed to no longer be mandatory performed by investigators. This amendment will reduce the number of site visits for subjects who have the option to conduct visits via a mobile nursing professional (similar to the option already available starting in Year 2 of the study). For subjects who must still go to the site for all assessments, this amendment will decrease the time they will spend on-site.

As part of this change, several minor adjustments have been made to the Schedule of Events:

- The PBMC assessment at Week 34 has been eliminated.
- The VWF-Ag assessment at Week 38 has been moved to Week 36.
- The exploratory biomarker assessment at Week 13 has been moved to Week 12.
- The urinalysis assessment at Week 38 has been moved to Week 36.
- At visits where the mobile nursing or lab draw-only option is used, physical examination and vital signs assessments will not be performed.
- At mobile nursing visits, the service will collect information regarding adverse events, changes to concomitant medications, bleeding episodes, and FVIII use. For lab draw-only visits, this information will be collected by site staff, by calling or emailing the subjects.



- 
2. Development of anti-FVIII inhibitory antibodies (inhibitors) has been added as an Event of Special Interest for safety reporting purposes.

**Rationale:** While development of FVIII neutralizing antibodies has not yet been observed in BMN 270 clinical studies, this change is being made to ensure timely reporting to health authorities.

3. Assessment of the Direct Thrombin Activity test has been removed.

**Rationale:** Based on the lack of correlation observed between FVIII activity levels and Direct Thrombin Activity results in Study 270-201, it has been determined that samples for this exploratory test will no longer be collected in Study 270-301.

4. Changes have been made to correct minor errors and for purposes of clarity and consistency.

Refer to Section [25](#) for a summary of revisions to Amendment 3 (dated 24 August 2018).



## 2 SYNOPSIS

|  |   |  |
|--|---|--|
| <p><b>NAME OF COMPANY</b><br/>BioMarin Pharmaceutical Inc.<br/>105 Digital Drive<br/>Novato, CA 94949</p> <p><b>NAME OF FINISHED PRODUCT:</b><br/>BMN 270</p> <p><b>NAME OF ACTIVE INGREDIENT:</b><br/>AAV5-hFVIII-SQ</p>  | <p><b>SUMMARY TABLE</b><br/>Referring to Part of the<br/>Dossier:</p> <p>Volume:</p> <p>Page:</p> <p>Reference:</p> | <p><b>FOR NATIONAL<br/>AUTHORITY USE<br/>ONLY:</b></p> |
| <p><b>TITLE OF STUDY:</b><br/>A Phase 3 Open-Label, Single-Arm Study To Evaluate The Efficacy and Safety of BMN 270, an Adeno-Associated Virus Vector-Mediated Gene Transfer of Human Factor VIII in Hemophilia A Patients with Residual FVIII Levels <math>\leq</math> 1 IU/dL Receiving Prophylactic FVIII Infusions</p>   |   |  |
| <p><b>PROTOCOL NUMBER:</b><br/>270-301</p>   |   |  |
| <p><b>STUDY SITES:</b><br/>Approximately 60 sites worldwide.</p>   |   |  |
| <p><b>PHASE OF DEVELOPMENT:</b><br/>Phase 3</p>  |   |  |
| <p><b>STUDY RATIONALE:</b><br/>Hemophilia A (HA) is an X-linked recessive bleeding disorder that affects approximately 1 in 5,000 males. It is caused by deficiency in the activity of coagulation factor VIII (FVIII), an essential cofactor in the intrinsic coagulation pathway. This disorder can be either inherited, due to a genetic aberrancy, or an acquired immunologic process, leading to insufficient quantities of FVIII or a dysfunctional FVIII, but all are characterized by a defective coagulation process. The clinical phenotype of HA patients generally correlates tightly with the level of residual expression. Severe HA is classified as FVIII activity less than 1% of wild-type (<math>&lt; 1</math> IU/dL), moderate disease comprises 1-5% of wild-type activity and the mild form is 5-40% activity. The clinical manifestations of severe HA are frequent spontaneous bleeding episodes, predominantly in joints and soft tissues, with a substantially increased risk of death from hemorrhage when the brain is involved. Subjects with moderate disease can exhibit manifestations similar to those seen in patients with severe HA, resulting in a comparable bleeding phenotype.<br/>Treatment of severe HA presently consists of intravenous injection of plasma-derived or recombinant human FVIII protein (rhFVIII) concentrates, both as prophylaxis 2-3 times per week, and at the time of a bleed, to prevent or control bleeding episodes, respectively. The half-life for FVIII (12 to 18 hours for most approved products) necessitates frequent infusions, and although a major advance in the treatment of HA, it remains common for severe HA patients to continue to have multiple bleeding events on prophylactic therapy (median ABR of 1-4 with prophylaxis treatment in a recently published retrospective observational study (Berntorp, 2017) and between 1-2 in 6 prospective FVIII interventional studies) and on-demand-only therapy (median ABR of 4.5-18 in a recently published retrospective study (Berntorp, 2017) and between 20-60 in</p> |   |  |



| <b>NAME OF COMPANY</b><br>BioMarin Pharmaceutical Inc.<br>105 Digital Drive<br>Novato, CA 94949<br><br><b>NAME OF FINISHED PRODUCT:</b><br>BMN 270<br><br><b>NAME OF ACTIVE INGREDIENT:</b><br>AAV5-hFVIII-SQ   | <b>SUMMARY TABLE</b><br>Referring to Part of the<br>Dossier:<br><br>Volume:<br><br>Page:<br><br>Reference: | <b>FOR NATIONAL<br/>           AUTHORITY USE<br/>           ONLY:</b> |
|---|--|---|
| <p>6 prospective FVIII interventional studies). The consequence of multiple bleeding events is the development of debilitating multiple-joint arthropathy and substantially increased risk of death. Chemical modification (eg, direct conjugation of polyethylene glycol (PEG) polymers) and bioengineering of FVIII (eg, FVIII-Fc fusion proteins) improve half-life by approximately 50%, and thus, show promise in reduced dosing and maintaining activity levels above a 1% trough for a greater proportion of the dosing interval. However, patients with severe HA who are treated with extended half-life FVIII remain dependent on multiple infusions to maintain critical levels of FVIII activity. There is therefore a strong unmet need for a fully preventive treatment of HA to give patients a FVIII level compatible with a normal and hemorrhage-free life.</p> <p>Gene therapy offers the potential of disease-modifying therapy by continuous endogenous production of active FVIII following a single intravenous infusion of a vector encoding the appropriate gene sequence for long-term episomal expression. Hemophilia A is well-suited for a gene replacement approach because clinical manifestations are attributable to the lack of a single gene product (FVIII) that circulates in minute amounts (200 ng/ml) in the plasma. Tightly regulated control of gene expression is not essential, and even modest increases in the level of FVIII (any increase of the plasma level by 2 ng/ml induces an increase in activity of 1%) can ameliorate the severe form of hemophilia A. Thus, relatively small changes in endogenous FVIII activity can result in clinically relevant improvements in disease phenotype. Finally, the circulating FVIII response to gene transduction can be assessed using validated quantitative rather than qualitative endpoints that are easily assayed using established laboratory techniques.</p> <p>Several different gene transfer strategies for FVIII replacement have been evaluated, but adeno-associated viral (AAV) vectors show the greatest promise. They have an excellent and well-defined safety profile, and can direct long-term transgene expression with tropism and promoter specificity for specific tissues, such as the liver (for serotypes 2, 5 and 8 among others). Indeed, an ongoing gene therapy clinical trial for a related disorder, hemophilia B, has established that stable (median follow-up of 3.2 years) expression of human factor IX (hFIX) at levels that are sufficient for conversion of their bleeding phenotype from severe to moderate or mild is achievable following a single peripheral vein infusion of AAV8-hFIX vector. Several participants in this trial have been able to discontinue factor prophylaxis without suffering spontaneous hemorrhages, even when they undertook activities that previously resulted in bleeding. Thus, gene therapy treatment has resulted in a substantial improvement in their quality of life (Nathwani, 2014).</p> <p>BMN 270 is an AAV5-based gene therapy vector that expresses the SQ form of hFVIII under the control of a hybrid human liver-specific promoter (Figure 1).</p> |  |   |



|   |  |   |
|---|--|---|
| <b>NAME OF COMPANY</b><br>BioMarin Pharmaceutical Inc.<br>105 Digital Drive<br>Novato, CA 94949<br><br><b>NAME OF FINISHED PRODUCT:</b><br>BMN 270<br><br><b>NAME OF ACTIVE INGREDIENT:</b><br>AAV5-hFVIII-SQ | <b>SUMMARY TABLE</b><br>Referring to Part of the<br>Dossier:<br><br>Volume:<br><br>Page:<br><br>Reference: | <b>FOR NATIONAL<br/>         AUTHORITY USE<br/>         ONLY:</b> |
|---|--|---|

**Figure 1. hFVIII-SQ Vector Genome Schematic**

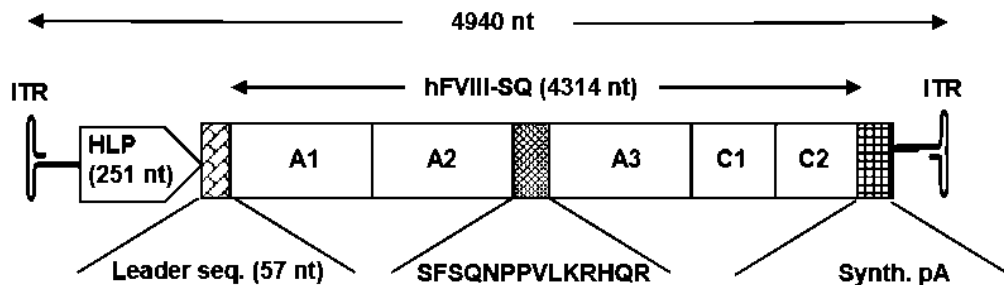

Legend –Note that schematic is not to scale; nt = nucleotides

BMN 270 will be delivered by a single intravenous dose and is designed to achieve stable, potentially life-long expression of active hFVIII in the plasma, synthesized from vector-transduced liver tissue.

BMN 270 is being evaluated in clinical study 270-201, an ongoing first-in-human, phase 1/2 dose escalation study in subjects with severe HA designed to assess the safety and efficacy of BMN 270 at various dose levels (6E12 vg/kg, 2E13 vg/kg, 4E13 vg/kg, 6E13 vg/kg). Specifically, 270-201 explores the relationship of vector dose to the augmentation of residual FVIII activity and whether these levels are sufficient to alter the clinical phenotype. Preliminary results from 270-201 have demonstrated that following gene transfer, FVIII activity above 15% (15 IU/dL) and, in many cases, within the normal range for FVIII, is achievable with a dose of 4-6E13 vg/kg with an acceptable safety profile (Pasi, 2017).

The current study is a Phase 3, single-arm, open-label study designed to assess whether, in an expanded sample, BMN 270 can safely alter the clinical phenotype of hemophilia A patients with residual FVIII activity  $\leq 1$  IU/dL.

**OBJECTIVES:**

The primary efficacy objective of the study is to:

- Assess the efficacy of BMN 270 defined as FVIII activity, as measured by chromogenic substrate assay, during Weeks 49-52 following intravenous infusion of BMN 270

The secondary efficacy objectives of the study are to:

- Assess the impact of BMN 270 on usage of exogenous FVIII replacement therapy from Week 5 to Week 52



| <b>NAME OF COMPANY</b><br>BioMarin Pharmaceutical Inc.<br>105 Digital Drive<br>Novato, CA 94949<br><br><b>NAME OF FINISHED PRODUCT:</b><br>BMN 270<br><br><b>NAME OF ACTIVE INGREDIENT:</b><br>AAV5-hFVIII-SQ   | <b>SUMMARY TABLE</b><br>Referring to Part of the<br>Dossier:<br><br>Volume:<br><br>Page:<br><br>Reference: | <b>FOR NATIONAL<br/>           AUTHORITY USE<br/>           ONLY:</b> |
|---|--|---|
| <ul style="list-style-type: none"> <li>Assess the impact of BMN 270 on the number of bleeding episodes requiring exogenous FVIII replacement therapy from Week 5 to Week 52</li> </ul> <p>The tertiary efficacy objective of the study is to:</p> <ul style="list-style-type: none"> <li>Assess the impact of BMN 270 on patient-reported outcomes (PROs) at Week 52 of the study compared to baseline</li> </ul> <p>The safety objectives of the study are to:</p> <ul style="list-style-type: none"> <li>Evaluate the safety of BMN 270 during the first 52 weeks following intravenous infusion</li> <li>Assess the long-term safety of BMN 270</li> </ul>   |  |   |
| <p><b>STUDY DESIGN AND PLAN:</b></p> <p>This is a Phase 3, single-arm, open-label study in hemophilia A patients with residual FVIII levels <math>\leq 1</math> IU/dL treated continuously with prophylactic exogenous FVIII for a minimum of one year prior to enrollment. Subjects will be enrolled at approximately 60 sites worldwide. Subjects must have high-quality, well-documented historical data available concerning previous bleeding episodes and exogenous FVIII usage over the previous 12 months in order to be eligible to enroll in the study.</p> <p>Approximately 130 adult subjects with severe HA will receive a 6E13 vg/kg dose of BMN 270 as a single intravenous infusion. Approximately 20 subjects will enroll in the study with at least 12 months of well-documented high-quality historical data concerning previous bleeding episodes and exogenous FVIII usage, while approximately 110 subjects will enroll in the study after having completed approximately 6 months' participation in the BioMarin-sponsored non-interventional study 270-902, in which bleeding and FVIII use data prior to gene therapy will be prospectively collected.</p> |  |   |

270-301 Amendment 4

Page 8

|   |   |   |
|---|---|---|
| <b>NAME OF COMPANY</b><br>BioMarin Pharmaceutical Inc.<br>105 Digital Drive<br>Novato, CA 94949<br><br><b>NAME OF FINISHED PRODUCT:</b><br>BMN 270<br><br><b>NAME OF ACTIVE INGREDIENT:</b><br>AAV5-hFVIII-SQ | <b>SUMMARY TABLE</b><br>Referring to Part of the Dossier:<br><br>Volume:<br><br>Page:<br><br>Reference: | <b>FOR NATIONAL AUTHORITY USE ONLY:</b> |
|---|---|---|

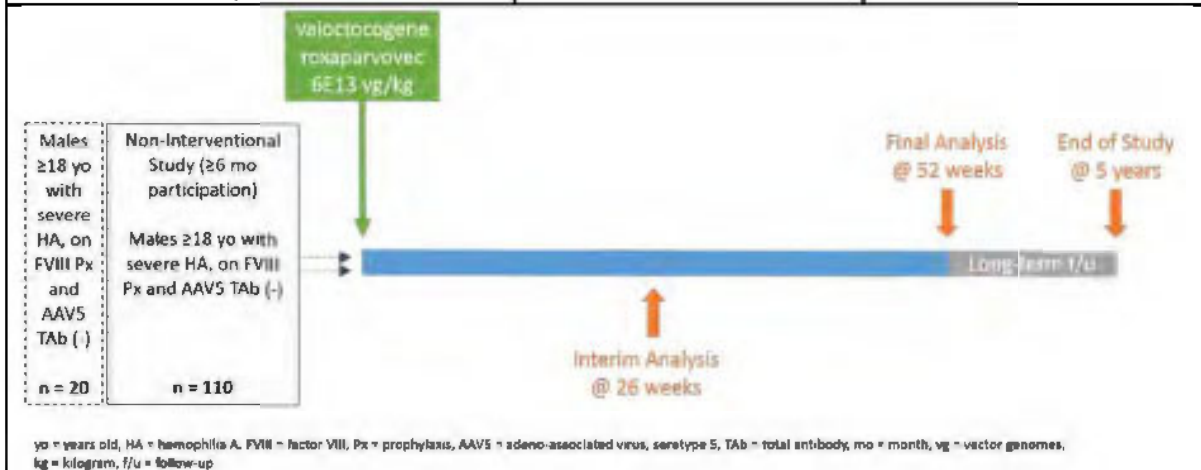

In order to minimize bias in the ongoing study and to assure safe and ethical conduct of the clinical trial, an independent Data Monitoring Committee (DMC), consisting of experts in clinical trials, statistics, and hemophilia, has been convened. The DMC will have sole access during the trial to amalgamated FVIII activity levels, FVIII usage, and bleeding data and review available safety and efficacy (eg, FVIII activity) data during the study on an ongoing basis; they may determine, based on emerging data and the risk/benefit profile, that further enrollment at 6E13 vg/kg should be discontinued in favor of a different dose of BMN 270, not to exceed 6E13 vg/kg. If the DMC recommends a dosing modification, then additional subjects may be enrolled, up to a total of approximately 130 subjects, at the new BMN 270 dose level (regardless of the number of subjects previously enrolled at 6E13 vg/kg).

An interim analysis is planned after 20 treated HIV-negative subjects have completed the Week 26 visit. Data will be reviewed by the DMC, based on the statistical analysis plan, and a formal recommendation will be made whether to continue the study as designed.

The final analysis for the study will be performed after all subjects have been followed for 52 weeks post-BMN 270 infusion. After the final analysis, safety and efficacy will then continue to be assessed long-term in all subjects for a total of approximately 5 years.

To avoid breakthrough bleeding, subjects will only discontinue exogenous prophylactic FVIII replacement therapy 4 weeks following infusion of BMN 270. Four weeks represents the time by which endogenous production of FVIII following gene transfer is expected to be efficacious, based on earlier results.



| <b>NAME OF COMPANY</b><br>BioMarin Pharmaceutical Inc.<br>105 Digital Drive<br>Novato, CA 94949<br><br><b>NAME OF FINISHED PRODUCT:</b><br>BMN 270<br><br><b>NAME OF ACTIVE INGREDIENT:</b><br>AAV5-hFVIII-SQ   | <b>SUMMARY TABLE</b><br>Referring to Part of the<br>Dossier:<br><br>Volume:<br><br>Page:<br><br>Reference: | <b>FOR NATIONAL<br/>           AUTHORITY USE<br/>           ONLY:</b> |
|---|--|---|
| <p>In subjects who experience recurring bleeding episodes, the Investigator and Medical Monitor will discuss whether to resume prior FVIII prophylaxis.</p> <p>Subjects who do not respond to BMN 270 treatment (ie, treatment failure, manifesting as either failure to achieve FVIII activity <math>\geq 5</math> IU/dL by Week 52 or inability to maintain independence from prophylactic FVIII replacement therapy due to joint bleeding episodes, in the judgment of the Investigator) may, at the Investigator's discretion and after discussion with the Medical Monitor or Sponsor-designated Data Monitor, follow an abbreviated visit schedule after Week 52 of the study by attending only the Q12W and End of Year visits during Years 2-5.</p> <p>There will be an ongoing review of individual subject safety by the Medical Monitor, and both safety and efficacy data by the DMC. Therapeutic oral corticosteroids may be initiated when a subject's ALT values are elevated, and subsequent dosage adjustments made, after consultation between the Investigator and the Medical Monitor.</p> <p>Any safety signal may trigger a review of the data and possible additional immunogenicity studies or other diagnostics deemed necessary that include an assessment of cellular immune responses using collected peripheral blood mononuclear cells (PBMCs).</p>   |  |   |
| <p><b>NUMBER OF SUBJECTS PLANNED:</b><br/>           Approximately 130 subjects may enroll into the study.</p>  |  |   |
| <p><b>DIAGNOSIS AND ALL CRITERIA FOR INCLUSION AND EXCLUSION:</b><br/>           Patients are eligible to be included in the study only if all of the following criteria apply:</p> <ol style="list-style-type: none"> <li>1. Males <math>\geq 18</math> years of age with hemophilia A and residual FVIII levels <math>\leq 1</math> IU/dL as evidenced by medical history, at the time of signing the informed consent.</li> <li>2. Must have been on prophylactic FVIII replacement therapy for at least 12 months prior to study entry. High-quality, well-documented historical data concerning bleeding episodes and FVIII usage over the previous 12 months must be available.</li> <li>3. Treated/exposed to FVIII concentrates or cryoprecipitate for a minimum of 150 exposure days (EDs).</li> <li>4. Willing and able to provide written, signed informed consent after the nature of the study has been explained and prior to any study-related procedures.</li> <li>5. No previous documented history of a detectable FVIII inhibitor, and results from a Bethesda assay or Bethesda assay with Nijmegen modification of less than 0.6 Bethesda Units (BU) (or less than 1.0 BU for laboratories with a historical lower sensitivity cutoff for inhibitor detection of 1.0 BU) on 2 consecutive occasions at least one week apart within the past 12 months (at least one of which should be tested at the central laboratory).</li> </ol> |  |   |



| <b>NAME OF COMPANY</b><br>BioMarin Pharmaceutical Inc.<br>105 Digital Drive<br>Novato, CA 94949<br><br><b>NAME OF FINISHED PRODUCT:</b><br>BMN 270<br><br><b>NAME OF ACTIVE INGREDIENT:</b><br>AAV5-hFVIII-SQ  | <b>SUMMARY TABLE</b><br>Referring to Part of the<br>Dossier:<br><br>Volume:<br><br>Page:<br><br>Reference: | <b>FOR NATIONAL<br/>           AUTHORITY USE<br/>           ONLY:</b> |
|--|--|---|
| <p>6. Sexually active participants must agree to use an acceptable method of effective contraception, either double-barrier contraception (ie, condom + diaphragm; or condom or diaphragm + spermicidal gel or foam) or their female partner either using hormonal contraceptives or having an intrauterine device. Participants must agree to contraception use for at least 12 weeks post-infusion; after 12 weeks, subjects may stop contraception use only if they have had 3 consecutive semen samples with no detectable viral vector DNA.</p> <p>7. Willing to abstain from alcohol consumption for at least the first 52 weeks following BMN 270 infusion.</p> <p>Patients are excluded from the study if any of the following criteria apply:</p> <ol style="list-style-type: none"> <li>1. Detectable pre-existing antibodies to the AAV5 capsid.</li> <li>2. Any evidence of active infection or any immunosuppressive disorder, including HIV infection.</li> <li>3. Significant liver dysfunction with any of the following abnormal laboratory results:               <ul style="list-style-type: none"> <li>• ALT (alanine aminotransferase) &gt; 1.25x ULN;</li> <li>• AST (aspartate aminotransferase) &gt; 1.25x ULN;</li> <li>• GGT (gamma-glutamyltransferase) &gt; 1.25x ULN;</li> <li>• Total bilirubin &gt; 1.25x ULN;</li> <li>• Alkaline phosphatase &gt; 1.25x ULN; or</li> <li>• INR (international normalized ratio) ≥ 1.4.</li> </ul> </li> </ol> <p>Subjects whose liver laboratory assessments fall outside of these ranges may undergo repeat testing of the entire liver test panel within the same Screening window and, if eligibility criteria are met on retest, may be enrolled after confirmation by the Medical Monitor.</p> <ol style="list-style-type: none"> <li>4. Prior liver biopsy showing significant fibrosis of 3 or 4 as rated on a scale of 0-4 on the Batts-Ludwig (<a href="#">Batts, 1995</a>) or METAVIR (<a href="#">Bedossa, 1996</a>) scoring systems, or an equivalent grade of fibrosis if an alternative scale is used.</li> <li>5. Evidence of any bleeding disorder not related to hemophilia A.</li> <li>6. Platelet count of &lt; 100 x 10<sup>9</sup>/L.</li> <li>7. Creatinine ≥ 1.5 mg/dL.</li> </ol> |  |   |



| <b>NAME OF COMPANY</b><br>BioMarin Pharmaceutical Inc.<br>105 Digital Drive<br>Novato, CA 94949<br><br><b>NAME OF FINISHED PRODUCT:</b><br>BMN 270<br><br><b>NAME OF ACTIVE INGREDIENT:</b><br>AAV5-hFVIII-SQ   | <b>SUMMARY TABLE</b><br>Referring to Part of the<br>Dossier:<br><br>Volume:<br><br>Page:<br><br>Reference: | <b>FOR NATIONAL<br/>           AUTHORITY USE<br/>           ONLY:</b> |
|---|--|---|
| <ol style="list-style-type: none"> <li>8. Liver cirrhosis of any etiology as assessed by liver ultrasound.</li> <li>9. Chronic or active hepatitis B as evidenced by positive serology testing (hepatitis B surface antigen [HBsAg], hepatitis B surface antibody [HBsAb], and hepatitis B core antibody [HBcAb]) and confirmatory HBV DNA testing. Refer to the Centers for Disease Control (CDC) table for the interpretation of serological test results in the Laboratory Manual.</li> <li>10. Active Hepatitis C as evidenced by detectable HCV RNA or currently on antiviral therapy.</li> <li>11. Active malignancy, except non-melanoma skin cancer.</li> <li>12. History of hepatic malignancy.</li> <li>13. History of arterial or venous thromboembolic events (eg, deep vein thrombosis, non-hemorrhagic stroke, pulmonary embolism, myocardial infarction, arterial embolus), with the exception of catheter-associated thrombosis for which anti-thrombotic treatment is not currently ongoing.</li> <li>14. Known inherited or acquired thrombophilia, including conditions associated with increased thromboembolic risk, such as atrial fibrillation.</li> <li>15. Treatment with any investigational product within 30 days or 5 half-lives of the investigational product prior to the screening period. For subjects who have received a prior investigational product, all ongoing adverse events (AEs) experienced while receiving that investigational product must have resolved prior to screening for this study.</li> <li>16. Any condition that, in the opinion of the Investigator or Sponsor would prevent the patient from fully complying with the requirements of the study (including possible corticosteroid treatment outlined in the protocol) and/or would impact or interfere with evaluation and interpretation of subject safety or efficacy result.</li> <li>17. Prior treatment with any vector or gene transfer agent.</li> <li>18. Major surgery planned in the 52-week period following the infusion with BMN 270.</li> <li>19. Use of systemic immunosuppressive agents, not including corticosteroids, or live vaccines within 30 days before the BMN 270 infusion.</li> <li>20. Concurrent enrollment in another clinical study, unless it is an observational (non-interventional) clinical study that does not interfere with the requirements of the current protocol or have the potential to impact the evaluation of efficacy and safety of BMN 270 and with prior consultation with the Medical Monitor.</li> </ol> |  |   |





|  |  |   |
|--|--|---|
| <b>NAME OF COMPANY</b><br>BioMarin Pharmaceutical Inc.<br>105 Digital Drive<br>Novato, CA 94949<br><br><b>NAME OF FINISHED PRODUCT:</b><br>BMN 270<br><br><b>NAME OF ACTIVE INGREDIENT:</b><br>AAV5-hFVIII-SQ  | <b>SUMMARY TABLE</b><br>Referring to Part of the<br>Dossier:<br><br>Volume:<br><br>Page:<br><br>Reference: | <b>FOR NATIONAL<br/>         AUTHORITY USE<br/>         ONLY:</b> |
| 21. Known allergy or hypersensitivity to BMN 270 investigational product formulation.<br>22. Unwilling to receive blood or blood products for treatment of an adverse event and/or a bleeding episode.   |  |   |
| <b>INVESTIGATIONAL PRODUCT(S), DOSE, ROUTE AND REGIMEN:</b><br>Each subject will receive a single intravenous infusion of BMN 270 at 6E13 vg/kg. The volume of infusion will depend on the subject's weight.   |  |   |
| <b>REFERENCE THERAPY(IES), DOSE, ROUTE AND REGIMEN:</b><br>No reference therapy will be evaluated in this study.   |  |   |
| <b>DURATION OF TREATMENT:</b><br>BMN 270 is given as a single dose by intravenous infusion.  |  |   |
| <b>CRITERIA FOR EVALUATION:</b><br><u>Efficacy:</u><br>Primary efficacy endpoint: <ul style="list-style-type: none"> <li>• Change of the hFVIII activity, as measured by chromogenic substrate assay, during Weeks 49-52 post-BMN 270 infusion from baseline. Each subject's hFVIII activity during Weeks 49-52 is defined as the median of the values obtained during this 4-week window. Values for hFVIII activity will be excluded if obtained within 72 hours since the last infusion of exogenous FVIII protein concentrates.</li> </ul> Secondary efficacy endpoints: <ul style="list-style-type: none"> <li>• Change in the annualized utilization (IU/kg) of exogenous FVIII replacement therapy during Week 5 to Week 52 post-BMN 270 infusion from the baseline utilization of exogenous FVIII replacement therapy.</li> <li>• Change in the annualized number of bleeding episodes requiring exogenous FVIII replacement treatment (annualized bleeding rate, ABR) during Week 5 to Week 52 of the study post-BMN 270 infusion from the baseline ABR.</li> </ul> Tertiary efficacy endpoints: <ul style="list-style-type: none"> <li>• Change from baseline in the total score of HAEMO-QoL-A at Week 52 of the study post-BMN 270 infusion.</li> <li>• Change from baseline in the EQ-5D-5L score at Week 52 of the study post-BMN 270 infusion.</li> <li>• Change from baseline in the Haemophilia Activities List (HAL) score at Week 52 of the study post-BMN 270 infusion.</li> </ul> |  |   |



| <b>NAME OF COMPANY</b><br>BioMarin Pharmaceutical Inc.<br>105 Digital Drive<br>Novato, CA 94949<br><br><b>NAME OF FINISHED PRODUCT:</b><br>BMN 270<br><br><b>NAME OF ACTIVE INGREDIENT:</b><br>AAV5-hFVIII-SQ   | <b>SUMMARY TABLE</b><br>Referring to Part of the<br>Dossier:<br><br>Volume:<br><br>Page:<br><br>Reference: | <b>FOR NATIONAL<br/>           AUTHORITY USE<br/>           ONLY:</b> |
|---|--|---|
| <ul style="list-style-type: none"> <li>• Change from baseline in the Work Productivity and Activity Impairment plus Classroom Impairment Questions: Hemophilia Specific (WPAI+CIQ:HS) score at Week 52 of the study post-BMN 270 infusion.</li> <li>• Change from baseline in Patient Reported Outcomes, Burdens, and Experiences (PROBE) score at Week 52 of the study post-BMN 270 infusion.</li> </ul> <p><u>Safety:</u></p> <p>The following safety outcome measurements will be assessed:</p> <ul style="list-style-type: none"> <li>• Incidence of adverse events (AEs) and serious AEs (SAEs)</li> <li>• Change in clinical laboratory tests (serum chemistry and hematology)</li> <li>• Change in vital signs</li> <li>• Change in physical examination</li> <li>• Vector shedding (blood, urine, semen, feces, saliva)</li> <li>• Liver tests (LTs, including ALT, AST, GGT, total bilirubin, and alkaline phosphatase)</li> <li>• Immune response to FVIII transgene product and AAV5 capsid proteins</li> </ul> <p>Each subject will have comprehensive surveillance monitoring of LTs (once per week for Weeks 1-36, and then once every 2 weeks from Weeks 37-52) during Year 1. LTs will be monitored every four weeks during Year 2 and then every 6 weeks during Years 3-5 post-dose in the safety extension; the frequency and duration of LT testing may be changed based on discussion between the Medical Monitor and the Investigator, review of subject data, and/or by independent DMC feedback.</p> <p>There will be a detailed assessment of cellular and humoral responses to AAV5 capsid and FVIII protein.</p> <p><u>Pharmacodynamics:</u></p> <p>The FVIII protein concentration and activity level as measured by a validated immunoassay and a validated FVIII activity assay, respectively, will be used for plasma profiles; FVIII protein and activity will be used to determine PD parameters.</p> |  |   |





| <b>NAME OF COMPANY</b><br>BioMarin Pharmaceutical Inc.<br>105 Digital Drive<br>Novato, CA 94949<br><br><b>NAME OF FINISHED PRODUCT:</b><br>BMN 270<br><br><b>NAME OF ACTIVE INGREDIENT:</b><br>AAV5-hFVIII-SQ   | <b>SUMMARY TABLE</b><br>Referring to Part of the<br>Dossier:<br><br>Volume:<br><br>Page:<br><br>Reference: | <b>FOR NATIONAL<br/>           AUTHORITY USE<br/>           ONLY:</b> |
|---|--|---|
| <p><b>STATISTICAL METHODS:</b></p> <p><u>Sample Size</u></p> <p>Approximately one hundred and thirty (130) subjects may be dosed in the study. The sample size for this study is based on clinical and statistical considerations in order to provide sufficient data to assess both safety and efficacy of BMN 270.</p> <p>For the primary endpoint, a sample size of 130 will provide at least 95% power to demonstrate that the change in hFVIII activity during Weeks 49-52 from baseline is greater than 0, assuming an effect size of 0.6, using a one-sample t-test with a 2-sided significance level of 0.05.</p> <p>For the secondary endpoints, the analyses will be performed utilizing exogenous FVIII use and bleeding episode data from the 110 subjects whose baseline data will be prospectively collected for approximately 6 months in the non-interventional study 270-902, prior to their enrollment in 270-301. An analytic sample size of 110 will provide at least 95% power to demonstrate that the change in the annualized utilization (IU/kg) of exogenous FVIII replacement therapy during Week 5 to Week 52 post-BMN 270 infusion from baseline is less than 0, assuming an effect size of 0.6, using a one-sample t-test with a 2-sided significance level of 0.05.</p> <p>An analytic sample size of 110 will also have at least 95% power to demonstrate that the change in the annualized number of bleeding episodes requiring exogenous FVIII replacement treatment (ABR) during Week 5 to Week 52 of the study post-BMN 270 infusion from the baseline ABR is less than 3.5 (non-inferiority margin), assuming the pre- and post-BMN 270 infusion population mean ABRs are 3.5 and 1 respectively, using a one-sample t-test with a 2-sided significance level of 0.05. Under the same assumptions, a sample size of 110 will have approximately 90% power to demonstrate that the change is less than 0, i.e. superiority of BMN 270 against FVIII prophylaxis.</p> <p>Overall, the planned sample size will have greater than 80% power for testing the primary and secondary efficacy endpoints hierarchically with a 2-sided significance level of 0.05.</p> <p><u>Analysis Population</u></p> <p>The intention-to-treat (ITT) population is defined as all subjects who receive BMN 270 infusion, and the modified intention-to-treat (mITT) population is defined as subjects who receive BMN 270 infusion and are HIV-negative. The mITT population will be used for the primary efficacy analysis, and the ITT population will be used for the supportive efficacy analysis. The ITT population will also be used for the safety analysis.</p> <p><u>Analysis</u></p> <p>For the primary efficacy endpoint at Week 52 (ie, the change in the hFVIII activity during Weeks 49-52 post-BMN 270 infusion from baseline, as measured by chromogenic substrate assay),</p> |  |   |



| <b>NAME OF COMPANY</b><br>BioMarin Pharmaceutical Inc.<br>105 Digital Drive<br>Novato, CA 94949<br><br><b>NAME OF FINISHED PRODUCT:</b><br>BMN 270<br><br><b>NAME OF ACTIVE INGREDIENT:</b><br>AAV5-hFVIII-SQ   | <b>SUMMARY TABLE</b><br>Referring to Part of the<br>Dossier:<br><br>Volume:<br><br>Page:<br><br>Reference: | <b>FOR NATIONAL<br/>           AUTHORITY USE<br/>           ONLY:</b> |
|---|--|---|
| <p>a one-sample t-test will be used to test the null hypothesis that the change is 0 or less against the alternative hypothesis that the change is greater than 0. Descriptive summaries of the proportions of subjects whose FVIII activity during Weeks 49-52 is greater than or equal to select thresholds, such as 15, 25 and 30 IU/dL, and the confidence intervals of the proportions will also be provided.</p> <p>For the secondary endpoints, the analyses will be performed on 110 subjects in the mITT population whose baseline data will be prospectively collected for approximately 6 months in the non-interventional study 270-902 prior to their enrollment in 270-301.</p> <p>For the first secondary efficacy endpoint at Week 52 (ie, the change in the annualized utilization (IU/kg) of exogenous FVIII replacement therapy during Weeks 5-52 post-BMN 270 infusion from baseline), a one-sample t-test will be performed to test the null hypothesis that the change is 0 or greater against the alternative hypothesis that the change is less than 0.</p> <p>For the second secondary efficacy endpoint at Week 52 (ie, the change in the annualized number of bleeding episodes requiring exogenous FVIII replacement treatment during Weeks 5-52 post-BMN 270 infusion from baseline), a one-sample t-test will be performed to test for non-inferiority of BMN 270 against FVIII prophylaxis (ie, the baseline ABR calculated using subjects' data collected in 270-902) using a margin of 3.5, ie, to test the null hypothesis that the change is 3.5 or greater against the alternative hypothesis that the change is less than 3.5. If non-inferiority is demonstrated, the test for superiority of BMN 270 against FVIII prophylaxis will be performed.</p> <p>The primary efficacy endpoint and secondary efficacy endpoints will be tested hierarchically according to the order described above.</p> <p>An interim analysis is planned after approximately 20 treated HIV-negative subjects have completed the Week 26 visit (or have discontinued study participation prior to Week 26). The primary efficacy endpoint for the interim analysis involves hFVIII activity, as measured by chromogenic substrate assay, achieved post-BMN 270 infusion, as detailed in the statistical analysis plan (SAP).</p> <p>Adjustment for multiplicity of the interim analysis at Week 26 and the final analysis at Week 52 will be described in the SAP (regardless of the interim analysis results, the study is planned to continue upon the DMC's recommendation, and the final analysis will be performed at Week 52). At the final analysis at Week 52, the secondary efficacy endpoints will be tested hierarchically.</p> <p>The secondary efficacy endpoints at the interim analysis (Week 26) will be summarized descriptively.</p> <p>The tertiary endpoints will be analyzed at the interim (Week 26) and final (Week 52) analyses, irrespective of the aforementioned hierarchical testing.</p> |  |   |



| <b>NAME OF COMPANY</b>   | <b>SUMMARY TABLE</b>                 | <b>FOR NATIONAL AUTHORITY USE ONLY:</b> |
|--|--------------------------------------|---|
| BioMarin Pharmaceutical Inc.<br>105 Digital Drive<br>Novato, CA 94949  | Referring to Part of the<br>Dossier: |   |
| NAME OF FINISHED PRODUCT:<br>BMN 270   | Volume:                              |   |
| NAME OF ACTIVE INGREDIENT:<br>AAV5-hFVIII-SQ   | Page:                                |   |
|  | Reference:                           |   |
| <p>Details of the interim analysis, including the control of Type I error rate, will be specified in the SAP.</p> <p>Analysis of safety endpoints will be primarily descriptive. The incidence of AEs will be summarized by system organ class, preferred term, relationship to study drug, seriousness, and severity. Clinical laboratory test values, vital signs, vector shedding and immune response parameters will be summarized descriptively by visit.</p> |                                      |   |



### 3 TABLE OF CONTENTS

|  |    |
|--|----|
| CLINICAL STUDY PROTOCOL AMENDMENT SUMMARY.....                         | 2  |
| 2 SYNOPSIS.....  | 4  |
| 3 TABLE OF CONTENTS.....   | 17 |
| 4 LIST OF ABBREVIATIONS AND DEFINITIONS OF TERMS.....                  | 22 |
| 5 ETHICS.....  | 25 |
| 5.1 Institutional Review Board or Independent Ethics Committee.....    | 25 |
| 5.2 Ethical Conduct of Study.....                                      | 25 |
| 5.3 Subject Information and Informed Consent.....                      | 26 |
| 6 INVESTIGATORS AND STUDY ADMINISTRATIVE STRUCTURE.....                | 27 |
| 7 INTRODUCTION.....  | 28 |
| 7.1 Nonclinical Studies.....   | 28 |
| 7.2 Previous Clinical Studies.....                                     | 29 |
| 7.3 Study Rationale.....   | 29 |
| 7.4 Summary of Overall Risks and Benefits.....                         | 32 |
| 8 STUDY OBJECTIVES.....  | 34 |
| 9 INVESTIGATIONAL PLAN.....  | 35 |
| 9.1 Overall Study Design and Plan.....                                 | 35 |
| 9.2 Discussion of Study Design, Including Choice of Control Group..... | 53 |
| 9.3 Selection of Study Population.....                                 | 53 |
| 9.3.1 Inclusion Criteria.....  | 53 |
| 9.3.2 Exclusion Criteria.....  | 54 |
| 9.3.3 Removal of Subjects from Treatment or Assessment.....            | 56 |
| 9.3.4 Subject Identification and Replacement of Subjects.....          | 58 |
| 9.3.5 Duration of Subject Participation.....                           | 58 |
| 9.4 Treatments.....  | 58 |
| 9.4.1 Treatments Administered.....                                     | 58 |
| 9.4.2 Identity of Investigational Product.....                         | 58 |
| 9.4.3 Storage.....   | 58 |
| 9.4.4 Directions for Administration.....                               | 59 |



|        |  |    |
|--------|--|----|
| 9.4.5  | Method of Assigning Subjects to Treatment Groups                 | 60 |
| 9.4.6  | Selection of Dose Used in the Study                              | 60 |
| 9.4.7  | Blinding   | 61 |
| 9.4.8  | Prior and Concomitant Medications                                | 61 |
| 9.4.9  | Treatment Compliance   | 64 |
| 9.5    | Investigational Product Accountability                           | 64 |
| 9.5.1  | Return and Disposition of Clinical Supplies                      | 64 |
| 9.6    | Dietary or Other Protocol Restrictions                           | 65 |
| 9.7    | Safety and Efficacy Variables                                    | 65 |
| 9.7.1  | Safety and Efficacy Measurements Assessed                        | 65 |
| 9.7.2  | Primary Efficacy Variables                                       | 65 |
| 9.7.3  | Secondary Efficacy Variables                                     | 66 |
| 9.7.4  | Tertiary Efficacy Variables                                      | 67 |
| 9.7.5  | Immunogenicity   | 68 |
| 9.7.6  | Pharmacodynamics   | 68 |
| 9.7.7  | Exploratory Assessments  | 68 |
| 9.7.8  | Safety Variables   | 69 |
| 10     | REPORTING ADVERSE EVENTS   | 77 |
| 10.1   | Safety Parameters and Definitions                                | 77 |
| 10.1.1 | Adverse Events   | 77 |
| 10.2   | Serious Adverse Events   | 78 |
| 10.2.1 | Events of Special Interest (EOSI)                                | 79 |
| 10.3   | Methods and Timing for Capturing and Assessing Safety Parameters | 79 |
| 10.3.1 | Adverse Event Reporting Period                                   | 79 |
| 10.3.2 | Eliciting Adverse Events   | 79 |
| 10.3.3 | Assessment of Seriousness, Severity, and Causality               | 79 |
| 10.4   | Procedures for Recording Adverse Events                          | 82 |
| 10.4.1 | Recording Adverse Events on a eCRF                               | 82 |
| 10.5   | Reporting Requirements   | 85 |
| 10.5.1 | Expedited Reporting Requirements                                 | 85 |



|   |    |
|---|----|
| 10.5.2 Institutional Review Board or Independent Ethics Committee Reporting Requirements..... | 86 |
| 10.6 Follow-up of Subjects after Adverse Events.....  | 86 |
| 10.7 Post-Study Adverse Events.....   | 86 |
| 10.8 Urgent Safety Measures.....  | 87 |
| 10.9 BioMarin Pharmacovigilance Contact Information.....                                      | 88 |
| 11 APPROPRIATENESS OF MEASUREMENTS.....   | 89 |
| 12 STUDY PROCEDURES.....  | 90 |
| 12.1 Prestudy.....  | 90 |
| 12.2 Screening Visit.....   | 90 |
| 12.2.1 “Smart Rescreening” Visit.....   | 91 |
| 12.3 Baseline Visit.....  | 92 |
| 12.4 Treatment Visit/BMN 270 Infusion Visit (Day 1).....                                      | 93 |
| 12.5 BMN 270 Infusion Follow-Up Visits – Weeks 1-26.....                                      | 94 |
| 12.5.1 Once per week (Weeks 1 through 26).....  | 94 |
| 12.5.2 Week 1 – Day 4.....  | 95 |
| 12.5.3 Week 1 – Day 8.....  | 95 |
| 12.5.4 Every 2 Weeks (Week 2, 4, 6, 8, 10, 12, 14, 16, 18, 20, 22, 24, and 26).....           | 95 |
| 12.5.5 Weeks 2, 4, 10, 16, 22, and 26.....  | 95 |
| 12.5.6 Weeks 2, 3, 4, 6, 8, 12, 16, 20, 24, and 26.....                                       | 95 |
| 12.5.7 Weeks 4, 12, and 26.....   | 95 |
| 12.5.8 Every 4 Weeks (Weeks 4, 8, 12, 16, 20, and 24) Plus Week 26.....                       | 96 |
| 12.5.9 Every 8 Weeks (Weeks 8, 16, and 24).....   | 96 |
| 12.5.10 Weeks 6, 12, 16, 20, 24, and 26.....  | 96 |
| 12.5.11 Weeks 12 and 26.....  | 96 |
| 12.5.12 Week 16.....  | 96 |
| 12.5.13 Week 20, 24, and 26.....  | 96 |
| 12.6 Post-Infusion Follow-Up – Weeks 27-52.....   | 97 |
| 12.6.1 Every Visit.....   | 97 |
| 12.6.2 Weeks 28, 30, 32, 36, 44, and 52.....  | 98 |





|        |   |     |
|--------|---|-----|
| 12.6.3 | Every 4 Weeks (Weeks 28, 32, 36, 40, 44, 48, 52)                              | 98  |
| 12.6.4 | Weeks 32, 36, 44, and 52  | 98  |
| 12.6.5 | Weeks 32, 36, 40, 44, 48, and 52  | 98  |
| 12.6.6 | Week 32, 36, and 52   | 98  |
| 12.6.7 | Week 36 and 52  | 98  |
| 12.6.8 | Week 52   | 99  |
| 12.7   | Post-Infusion Follow-Up – Years 2-5   | 99  |
| 12.7.1 | Year 2 – Every 4 Weeks (not required for treatment failure)                   | 100 |
| 12.7.2 | Years 3-5 – Every 6 Weeks (not required for treatment failure)                | 101 |
| 12.7.3 | Years 2-5 – Every 12 Weeks and End of Year Visits (required for all subjects) | 102 |
| 12.8   | Early Termination Visit   | 103 |
| 12.9   | End of Study  | 105 |
| 13     | DATA QUALITY ASSURANCE  | 106 |
| 14     | STATISTICAL METHODS AND DETERMINATION OF SAMPLE SIZE                          | 107 |
| 14.1   | Statistical and Analytical Plans  | 107 |
| 14.1.1 | Interim Analyses  | 107 |
| 14.1.2 | Procedures for Accounting for Missing, Unused and Spurious Data               | 107 |
| 14.2   | Primary Efficacy Endpoint   | 107 |
| 14.3   | Secondary Efficacy Endpoints  | 108 |
| 14.4   | Immunogenicity  | 109 |
| 14.5   | Pharmacodynamic Analyses  | 109 |
| 14.6   | Safety Analysis   | 109 |
| 14.7   | Determination of Sample Size  | 110 |
| 14.8   | Analysis Populations  | 111 |
| 14.9   | Changes in the Conduct of the Study or Planned Analyses                       | 111 |
| 15     | DATA MONITORING COMMITTEE   | 112 |
| 16     | COSTS, COMPENSATION, AND SUBJECT INJURY                                       | 113 |
| 17     | CASE REPORT FORMS AND SOURCE DOCUMENTS  | 114 |
| 18     | STUDY MONITORING AND AUDITING   | 116 |
| 19     | RETENTION OF RECORDS  | 117 |



|  |     |
|--|-----|
| 20 USE OF INFORMATION AND PUBLICATION .....                  | 118 |
| 21 REFERENCES .....  | 119 |
| 22 INVESTIGATOR RESPONSIBILITIES .....                       | 122 |
| 22.1 Conduct of Study and Protection of Human Patients ..... | 122 |
| 23 SIGNATURE PAGE .....                                      | 123 |
| 24 APPENDIX 1: SAMPSON'S ANAPHYLAXIS CRITERIA .....          | 124 |
| 25 PROTOCOL AMENDMENT TEXT REVISIONS .....                   | 125 |

### LIST OF TABLES

|  |    |
|--|----|
| Table 9.1.1: Schedule of Events – Screening and Infusion .....                         | 38 |
| Table 9.1.2: Schedule of Events – Post-Infusion Follow-Up (Week 1-16) .....            | 41 |
| Table 9.1.3: Schedule of Events – Post-Infusion Follow-Up (Week 17-32) .....           | 44 |
| Table 9.1.4: Schedule of Events – Post-Infusion Follow-Up (Week 33 – Week 52) .....    | 47 |
| Table 9.1.5: Schedule of Events – Post-Infusion Follow-Up (Year 2 – Year 5) .....      | 49 |
| Table 9.1.6: Schedule of Events – Therapeutic Corticosteroids for ALT Elevations ..... | 52 |
| Table 9.4.8.2.1: Adjustments to Corticosteroid Regimen .....                           | 63 |
| Table 9.7.8.2.1: Clinical Laboratory Tests .....                                       | 70 |
| Table 9.7.8.3.1: Liver Tests .....   | 72 |
| Table 9.7.8.3.2: Evaluation of ALT Elevations .....                                    | 73 |
| Table 9.7.8.3.3: Viral and Autoimmune Hepatitis Testing .....                          | 74 |
| Table 10.3.3.2.1: Adverse Event Grading (Severity) Scale .....                         | 80 |
| Table 10.3.3.3.1: Causality Attribution Guidance .....                                 | 81 |

### LIST OF FIGURES

|   |    |
|---|----|
| Figure 1: hFVIII-SQ Vector Genome Schematic .....     | 6  |
| Figure 7.3.1: hFVIII-SQ Vector Genome Schematic ..... | 31 |





---

#### 4 LIST OF ABBREVIATIONS AND DEFINITIONS OF TERMS

|         |  |
|---------|--|
| AAV     | adeno-associated virus                                     |
| ABR     | annualized bleeding rate                                   |
| ADL     | activities of daily living                                 |
| ADR     | adverse drug reaction                                      |
| AE      | adverse event  |
| ALT     | alanine aminotransferase                                   |
| APTT    | activated partial thromboplastin time                      |
| ART     | anti-retroviral therapy                                    |
| AST     | aspartate aminotransferase                                 |
| BPV     | BioMarin Pharmacovigilance                                 |
| BU      | Bethesda Unit  |
| CFR     | Code of Federal Regulations                                |
| CRA     | clinical research associate                                |
| CRF     | case report form   |
| CSR     | clinical study report                                      |
| CTCAE   | Common Terminology Criteria for Adverse Events             |
| DMC     | Data Monitoring Committee                                  |
| eCRF    | electronic case report form                                |
| ED      | exposure days  |
| EOSI    | events of special interest                                 |
| ETV     | early termination visit                                    |
| EudraCT | European Union Drug Regulating Authorities Clinical Trials |
| FDA     | Food and Drug Administration                               |
| FIH     | first-in-human   |
| FVIII   | coagulation factor VIII                                    |
| GCP     | Good Clinical Practice                                     |
| GGT     | gamma-glutamyltransferase                                  |
| HA      | Hemophilia A   |
| HAL     | Haemophilia Activities List                                |
| HBcAb   | hepatitis B core antibody                                  |
| HBsAb   | hepatitis B surface antibody                               |
| HBsAg   | hepatitis B surface antigen                                |
| hFIX    | human coagulation factor IX                                |
| hFVIII  | human coagulation factor VIII                              |



---

|             |   |
|-------------|---|
| HIPAA       | Health Insurance Portability and Accountability Act   |
| IB          | investigator brochure   |
| ICF         | informed consent form   |
| ICH         | International Conference on Harmonisation of Technical Requirements for Registration of Pharmaceuticals for Human Use |
| ICH E6 [R2] | ICH Harmonised Tripartite Guideline: Guideline for Good Clinical Practice E6  |
| IEC         | independent ethics committee  |
| IND         | Investigational New Drug (application)  |
| INR         | international normalized ratio  |
| IP          | investigational product   |
| IRB         | institutional review board  |
| ITT         | Intention-to-treat  |
| IV          | intravenous   |
| LT          | liver test  |
| MedDRA      | Medical Dictionary for Regulatory Activities  |
| mITT        | Modified intention-to-treat   |
| MN          | mobile nursing  |
| PBMC        | peripheral blood mononuclear cells  |
| PCR         | polymerase chain reaction   |
| PD          | pharmacodynamics  |
| PEG         | polyethylene glycol   |
| PK          | Pharmacokinetics  |
| PRO         | patient-reported outcome  |
| rhFVIII     | recombinant human FVIII protein   |
| REB         | research ethics board   |
| SAE         | serious adverse event   |
| SAP         | statistical analysis plan   |
| SDV         | source data verification  |
| TGA         | thrombin generation assay   |
| ULN         | upper limit of normal   |
| vg          | vector genomes  |
| VWF:Ag      | von Willebrand factor Antigen   |
| WPAI+CIQ:HS | Work Productivity and Activity Impairment plus Classroom Impairment Questions: Hemophilia Specific                    |

**Definition of Terms:**

## Investigational Product (IP):

“A pharmaceutical form of an active ingredient or placebo being tested or used as a reference in a clinical trial, including a product with a marketing authorization when used or assembled (formulated or packaged) in a way different from the approved form, or when used for an unapproved indication, or when used to gain further information about an approved use” (from International Conference on Harmonisation of Technical Requirements for Registration of Pharmaceuticals for Human Use ICH Harmonised Tripartite Guideline: Guideline for Good Clinical Practice E6 [ICH E6 (R2)]).

The terms “IP” and “study drug” may be used interchangeably in the protocol.



---

## 5 ETHICS

BioMarin Pharmaceutical Inc. (hereafter referred to as BioMarin or the Sponsor) conducts its studies according to the highest ethical and scientific standards. The following sections articulate standards to which Investigators will be held accountable, as well as matters of compliance to document adherence to such standards.

### 5.1 Institutional Review Board or Independent Ethics Committee

Investigators are expected to interact with Ethics Committees (ECs) promptly, as required, during the course of the study. This includes, but is not limited to, providing appropriate documentation to support study initiation and maintaining appropriate flow of safety and other information during the course of the study and for study close-out activities. BioMarin (or designee) will assist Investigators with access to timely and accurate information and with assurance of prompt resolution of any queries.

Prior to initiating the study, the Investigator will obtain written confirmation that the institutional review board (IRB) or independent ethics committee (IEC) [for Canadian protocols, Research Ethics Board (REB)] is properly constituted and compliant with International Conference on Harmonisation of Technical Requirements for Registration of Pharmaceuticals for Human Use (ICH) and Good Clinical Practice (GCP) requirements, applicable laws and local regulations. A copy of the confirmation from the IRB/IEC/REB will be provided to BioMarin or its designee. The Investigator will provide the IRB/IEC/REB with all appropriate material, including the protocol, Investigator's Brochure (IB), the Informed Consent Form (ICF) including compensation procedures, and any other written information provided to the subjects, including all ICFs translated for patients who do not speak the local language at the clinical site. The study will not be initiated and Investigational Product (IP) supplies will not be shipped to the site until appropriate documents from the IRB/IEC/REB confirming unconditional approval of the protocol, the ICF and all subject recruitment materials are obtained in writing by the Investigator and copies are received at BioMarin or its designee. The approval document should refer to the study by protocol title and BioMarin protocol number (if possible), identify the documents reviewed, and include the date of the review and approval. BioMarin will ensure that the appropriate reports on the progress of the study are made to the IRB/IEC/REB and BioMarin by the Investigator in accordance with applicable guidance documents and governmental regulations.

### 5.2 Ethical Conduct of Study

It is expected that Investigators understand and comply with the protocol. This includes, but is not limited to: establishing and meeting enrollment commitments, including providing



eligible subjects for study enrollment; adhering to adverse event reporting, diagnostic, or other procedures as specified in the protocol; and assuring appropriate compliance with study treatment administration and accountability.

This study will be conducted in accordance with the following:

- European Clinical Trial Directive 2001/20/EC and Good Clinical Practice Directive 2005/28/EC, for studies conducted within any European country
- US Code of Federal Regulations (CFR) sections that address clinical research studies, and/or other national and local regulations, as applicable
- ICH Harmonised Tripartite Guideline: Guideline for Good Clinical Practice E6 (ICH E6) or E6(R2) (ICH E6R2) if adopted

Specifically, this study is based on adequately performed laboratory and animal experimentation and human Phase 1 study testing. The study will be conducted under a protocol reviewed and approved by an IRB/IEC/REB and will be conducted by scientifically and medically qualified persons. The potential benefits of the study are in proportion to the potential risks. The rights and welfare of the subjects will be respected and the Investigators conducting the study do not find the hazards to outweigh the potential benefits. Each subject will provide written, informed consent before any study-related tests or evaluations are performed.

### **5.3 Subject Information and Informed Consent**

A properly written and executed informed consent form (ICF), in compliance with ICH E6 (Section 4.8), United States Code of Federal Regulations (CFR) 21 CFR §50, European Clinical Trial Directive 2001/20/EC and Good Clinical Practice Directive 2005/28/EC, and other applicable local regulations, will be obtained for each subject prior to entering the subject into the study. The Investigator will prepare the ICF and provide the documents to BioMarin for approval prior to submission to the IRB/IEC/REB. BioMarin and the IRB/IEC/REB must approve the documents before they are implemented. A copy of the approved ICF, and if applicable, a copy of the approved subject information sheet and all ICFs translated to a language other than the native language of the clinical site must also be received by BioMarin or designee prior to any study-specific procedures being performed.

The Investigator will provide copies of the signed ICF to each subject and will maintain the original in the record file of the subject.



---

## 6 INVESTIGATORS AND STUDY ADMINISTRATIVE STRUCTURE

During administration of informed consent, expectations regarding participation in the study should be made clear to subjects. Patients who are not willing and/or are not able to comply with all aspects of the study should not be encouraged to participate.

Prior to beginning the study, the Investigator at each site must provide to BioMarin or designee a fully executed and signed Statement of Investigator (SOI) form. A US Food and Drug Administration (FDA) Form FDA 1572 serves as an acceptable SOI form. If Form FDA 1572 may not be used in a particular region, the Investigator must provide a fully executed SOI on the form provided by the Sponsor. All Investigators and Sub-Investigators must be listed on Form FDA 1572 or its equivalent SOI. Financial Disclosure Forms must also be completed for all Investigators and Sub-Investigators listed on the Form FDA 1572 or SOI who will be directly involved in the treatment or evaluation of subjects in this study.

The study will be administered by and monitored by employees or representatives of BioMarin. Clinical research associates (CRAs) or trained designees will monitor each site on a periodic basis and perform verification of source documentation for each subject as well as other required review processes. BioMarin's Regulatory Affairs Department (or designee) will be responsible for the timely reporting of serious adverse events (SAEs) to appropriate regulatory authorities as required.

In multicenter studies, a Coordinating Investigator will be identified who will be responsible for study overview. The Coordinating Investigator will read the clinical study report (CSR) and confirm that it accurately describes the conduct and results of the study, to the best of his or her knowledge. The Coordinating Investigator will be chosen on the basis of active participation in the study, ability to interpret data, and willingness to review and sign the report in a specified timeframe. The identity of the Coordinating Investigator and a list of all Investigators participating in the study will be provided in the CSR.

Clinical Laboratory assessments will be performed at a nominated central laboratory. Bioanalytical samples will be sent to the appropriate specialty laboratories for testing. Refer to laboratory manual for more details.

## 7 INTRODUCTION

Hemophilia A (HA) is an X-linked recessive bleeding disorder that affects approximately 1 in 5,000 males (Nathwani, 1992, *Baillieres Clin.Haematol.*). It is caused by mutations in the factor VIII (FVIII) gene that codes for FVIII protein, an essential cofactor in the coagulation pathway. Clinical manifestations of severe FVIII deficiency are frequent unprovoked bleeding episodes in joints and soft tissues causing permanent disability and occasionally death mostly after brain hemorrhage. Treatment in Western countries (Berntorp, 2012, *Haemophilia.*) consists of intravenous injection of plasma-derived or recombinant FVIII protein concentrates at the time of a bleed to control it or prophylactically to prevent bleeding episodes. The short half-life for FVIII (~8-12 hours) necessitates frequent infusions and makes this treatment prohibitively expensive for the majority of the world's hemophilia A patients. These individuals develop debilitating arthropathy and have a substantially increased risk of death from hemorrhage in life (Stonebraker, 2010, *Haemophilia.*). Chemical modification or bioengineering of FVIII may improve half-life to 18-19 hours (Kaufman, 2013, *Blood*). However, these extended half-life FVIII variants do not eliminate the need for lifelong FVIII protein administration (Hay, 2012, *Blood*).

Gene therapy offers the potential of disease-modifying therapy by continuous endogenous production of human FVIII (hFVIII) following a single administration of vector. Hemophilia A is well-suited for this approach because its clinical manifestations are attributable to the lack of a single gene product (FVIII) that circulates in low amounts (100-200 ng/ml) in the plasma. Tightly regulated control of gene expression is not essential, and a modest increase in the level of FVIII (a plasma level of 2 ng/ml protein leads to a 1% expression) can ameliorate the severe phenotype (Srivastava, 2013, *Haemophilia.*); thus, the therapeutic goal for gene therapy is a modest increase in hFVIII. Finally, the consequences of gene transfer can be assessed using simple quantitative rather than qualitative endpoints that can be easily assayed in most clinical laboratories.

BMN 270 contains the cDNA for the B-domain-deleted SQ FVIII with a liver-specific HLP transcription promoter. The expression cassette is inserted between AAV2 ITRs, and this genome is packaged in the AAV5 capsid. A comprehensive review of BMN 270 is contained in the IB supplied by BioMarin. Investigators are to review this document prior to initiating this study.

### 7.1 Nonclinical Studies

The nonclinical program supports a single IV infusion of BMN 270, the planned clinical route of administration, for the treatment of hemophilia A in male patients. This nonclinical



program took into account the guidelines and reflection papers for gene therapy medicinal products under EMA Advanced Therapies as well as FDA guidance. The primary pharmacodynamics (PD), pharmacokinetics (PK), and toxicity of IV BMN 270 were characterized in a series of single dose studies in species that were vector permissive and responsive to the transgene including normal CD-1 mice, a B- and T-cell deficient mouse model of hemophilia A (B6;129S-*Fcγ2m1Kaz*/J x B6.129S6-*Rag2<sup>tm1Fwa</sup>* N12; FVIII KO x Rag2), and normal cynomolgus and rhesus monkeys. Some PD studies evaluated additional PK, immunogenicity and toxicity endpoints.

Results of the nonclinical program to date are detailed in the IB supplied by BioMarin. Investigators are to review this document prior to initiating this study.

## 7.2 Previous Clinical Studies

Study BMN 270-201 is an ongoing Phase 1/2, dose-escalation study to assess the safety, tolerability, and efficacy of BMN 270 in patients with severe hemophilia A (FVIII  $\leq 1$  IU/dL). Subjects received a single BMN 270 infusion and are to be followed for safety and efficacy for up to 5 years. A total of 15 subjects have been enrolled at one of 4 dose levels (6E12, 2E13, 4E13, and 6E13 vg/kg).

A comprehensive review of safety, efficacy, and immunogenicity results from 270-201 as of the latest data cut is contained in the IB supplied by BioMarin. Investigators are to review this document prior to initiating this study.

## 7.3 Study Rationale

Hemophilia A (HA) is an X-linked recessive bleeding disorder that affects approximately 1 in 5,000 males. It is caused by deficiency in the activity of coagulation factor VIII (FVIII), an essential cofactor in the intrinsic coagulation pathway. This disorder can be either inherited, due to a genetic aberrancy or an acquired immunologic process, leading to insufficient quantities of FVIII or a dysfunctional FVIII, but all are characterized by a defective coagulation process. The clinical phenotype of HA patients generally correlates tightly with the level of residual expression. Severe HA is classified as FVIII activity less than 1% of wild type ( $< 1$  IU/dL), moderate disease comprises 1-5% of wild-type activity and the mild form is 5-40% activity. The clinical manifestations of severe HA are frequent spontaneous bleeding episodes, predominantly in joints and soft tissues, with a substantially increased risk of death from hemorrhage when the brain is involved. Subjects with moderate disease can exhibit manifestations similar to those seen in patients with severe HA, resulting in a comparable bleeding phenotype.





Treatment of severe HA presently consists of intravenous injection of plasma derived or recombinant human FVIII protein (rhFVIII) concentrates both as prophylaxis 2-3 times per week, and at the time of a bleed, to prevent or control bleeding episodes, respectively. The half-life for FVIII (12 to 18 hours for most approved products) necessitates frequent infusions, and although a major advance in the treatment of HA, it remains common for severe HA patients to continue to have multiple bleeding events on prophylactic therapy (median ABR of 1-4 with prophylaxis treatment in a recently published retrospective observational study (Berntorp, 2017) and between 1-2 in 6 prospective FVIII interventional studies) and on-demand-only therapy (median ABR of 4.5-18 in a recently published retrospective study (Berntorp, 2017) and between 20-60 in 6 prospective FVIII interventional studies). The consequence of multiple bleeding events is the development of debilitating multiple-joint arthropathy and substantially increased risk of death. Chemical modification (eg, direct conjugation of polyethylene glycol (PEG) polymers) and bioengineering of FVIII (eg, FVIII-Fc fusion proteins) improve half-life by approximately 50%, and thus, show promise in reduced dosing and maintaining activity levels above 1% trough for a greater proportion of the dosing interval. However, these extended half-life FVIII variants remain dependent on multiple infusions to maintain critical levels of FVIII activity in severe HA patients. There is therefore a strong unmet need for a fully preventive treatment of HA to give patients a FVIII level compatible with a normal and hemorrhage-free life.

Gene therapy offers the potential of disease-modifying therapy by continuous endogenous production of active FVIII following a single intravenous infusion of a vector encoding the appropriate gene sequence for long-term episomal expression. Hemophilia A is well-suited for a gene replacement approach because clinical manifestations are attributable to the lack of a single gene product (FVIII) that circulates in minute amounts (200 ng/ml) in the plasma. Tightly regulated control of gene expression is not essential, and even modest increases in the level of FVIII (any increase of the plasma level by 2 ng/ml induces an increase in activity of 1%) can ameliorate the severe form of the disease. Thus, relatively small changes in endogenous FVIII activity can result in clinically relevant improvements in disease phenotype. Finally, the circulating FVIII response to gene transduction can be assessed using validated quantitative rather than qualitative endpoints that are easily assayed using established laboratory techniques.

Several different gene transfer strategies for FVIII replacement have been evaluated, but adeno-associated viral (AAV) vectors show the greatest promise. They have an excellent and well-defined safety profile, and can direct long term transgene expression with tropism and promoter specificity for specific tissues such as the liver (for serotypes 2, 5 and 8 among

others). Indeed, an on-going gene therapy clinical trial for a related disorder, hemophilia B, has established that stable (median follow-up of 3.2 years) expression of human factor IX (hFIX) at levels that are sufficient for conversion of their bleeding phenotype from severe to moderate or mild is achievable following a single peripheral vein infusion of AAV8-hFIX vector. Several participants in this trial have been able to discontinue factor prophylaxis without suffering spontaneous hemorrhages, even when they undertook activities that previously resulted in bleeding. Thus, gene therapy treatment has resulted in a substantial improvement in their quality of life (Nathwani, 2014).

BMN 270 is an AAV5-based gene therapy vector that expresses the SQ form of hFVIII under the control of a hybrid human liver-specific promoter (Figure 7.3.1).

**Figure 7.3.1: hFVIII-SQ Vector Genome Schematic**

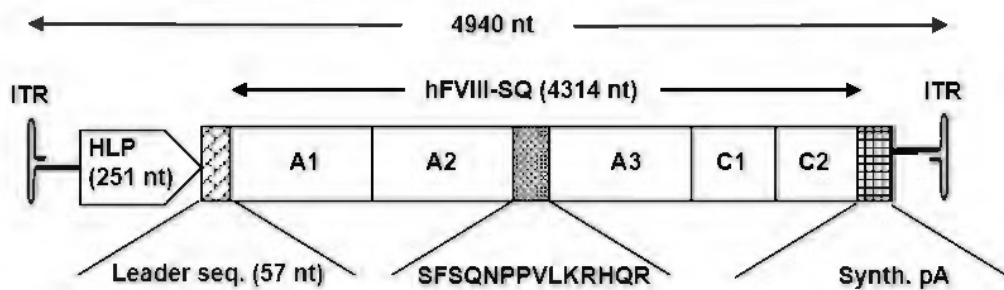

Legend –Note that schematic is not to scale; nt = nucleotides

BMN 270 will be delivered by a single intravenous dose and is designed to achieve stable, potentially life-long expression of active hFVIII in the plasma, synthesized from vector-transduced liver tissue.

BMN 270 is being evaluated in clinical study 270-201, an ongoing first-in-human, phase 1/2 dose escalation study in subjects with severe HA designed to assess the safety and efficacy of BMN 270 at various dose levels (6E12 vg/kg, 2E13 vg/kg, 4E13 vg/kg, 6E13 vg/kg).

Specifically, 270-201 explores the relationship of vector dose to the augmentation of residual FVIII activity and whether these levels are sufficient to alter the clinical phenotype.

Preliminary results from 270-201 have demonstrated that following gene transfer, FVIII activity above 15% (15 IU/dL) and, in many cases, within the normal range for FVIII, is achievable with a dose of 4-6E13 vg/kg with an acceptable safety profile (Pasi, 2017). For additional information on preliminary data in 270-201, refer to the current version of the Investigator's Brochure.

The current study is a Phase 3, single-arm, open-label study designed to assess whether, in an expanded sample, BMN 270 can safely alter the clinical phenotype of hemophilia A patients with residual FVIII activity  $\leq 1$  IU/dL.

#### 7.4 Summary of Overall Risks and Benefits

The majority of subjects in the ongoing 270-201 clinical study who have received 4E13 or 6E13 vg/kg doses of BMN 270 have had Grade 1 asymptomatic elevations in ALT. For most subjects, the elevations have reached only slightly above the ULN. Based on the effectiveness of transient oral corticosteroid used to suppress a presumed cytotoxic T-cell response in prior studies with hepatic transduction with AAV vectors (Mingozzi, 2013), subjects were treated with 7-32 weeks of oral corticosteroids preventatively or in response to the elevations in ALT to ensure preservation of the transduced hepatocytes. Using this approach, no sustained loss of FVIII activity has been observed in subjects with ALT elevations, consistent with maintaining a high level of hepatocyte function. Moreover, the rise in ALT levels were not accompanied by significant or lasting aberrations in other liver tests such as AST, bilirubin or albumin, indicating that extent of toxicity is limited. There has been one HIV-positive subject in the ongoing 270-302 clinical study who experienced Grade 3 asymptomatic elevations in ALT and AST, which has been attributed to an interaction between one or more of his antiretroviral therapy medications and/or unsuspected underlying hepatic disease with BMN 270. In addition, there has been one subject with Gilbert's syndrome in the ongoing 270-301 clinical study who has experienced Grade 3 asymptomatic elevations in ALT and AST. These cases have led to the exclusion of subsequent HIV-positive subjects and requirement of liver tests at Screening that are  $<1.25$  times the upper limit of the normal range in the ongoing 270-301 and 270-302 clinical studies. Of note, two HIV-positive subjects in 270-301 and one presumed Gilbert's syndrome subject in 270-201 have received BMN 270 without experiencing any elevations in ALT to date. Overall, the literature and clinical experience with BMN 270 thus far suggest that transient elevations in liver enzymes are expected following AAV-based gene therapy for the treatment for hemophilia A or B without any long-term concerns of hepatic injury (Manno, 2006); (Nathwani, 2011); (George, 2016); (Miesbach, 2016); (Pasi, 2017).

At the highest dose tested in 270-201 (6E13 vg/kg), the majority of subjects achieved FVIII levels above 50 IU/dL at 52 weeks post-infusion. Subjects in that cohort also reported markedly decreased bleeding compared with pre-study rates and the ability to discontinue prophylactic FVIII infusions. Subjects at all dose levels continue to be followed.

As with any infused biological product, there is a potential risk of acute, systemic hypersensitivity reactions (including anaphylaxis) with BMN 270. No hypersensitivity



---

reactions were observed during dosing of BMN 270 in the 270-201 clinical study, although one SAE of pyrexia was reported approximately 16 hours after the infusion in a subject in the 4E13 vg/kg cohort. The subject was treated with acetaminophen, and the fever resolved within 48 hours (see Investigator's Brochure for full details). Infusion-related reactions, including allergic reaction, maculopapular rash, and presyncope, have been reported from ongoing, actively dosing clinical studies of BMN 270, including this study. All of the infusion-related reactions were effectively managed clinically and resolved without any clinical sequelae. Refer to the Investigator's Brochure for additional details.

The current data available for BMN 270 does not yet permit adequate assessment of the benefit:risk profile of this investigational drug. Given the monitoring measures in place in the clinical protocol(s) to minimize the risk to subjects participating in the existing studies, the identified risks are justified by the anticipated benefits that may be afforded to subjects. Each subject in 270-301 will have a comprehensive surveillance plan that monitors LTs during the study, and elevations in LTs will be addressed according to the guidelines set forth in the protocol. Safety will be assessed by adverse event reporting and clinical laboratory assessments.

For additional information on findings in 270-201, refer to the current version of the Investigator's Brochure.



## 8 STUDY OBJECTIVES

The primary efficacy objective of the study is to:

- Assess the efficacy of BMN 270 defined as FVIII activity, as measured by chromogenic substrate assay, during Weeks 49-52 following intravenous infusion of BMN 270

The secondary efficacy objectives of the study are to:

- Assess the impact of BMN 270 on usage of exogenous FVIII replacement therapy from Week 5 to Week 52
- Assess the impact of BMN 270 on the number of bleeding episodes requiring exogenous FVIII replacement therapy from Week 5 to Week 52

The tertiary efficacy objective of the study is to:

- Assess the impact of BMN 270 on patient-reported outcomes (PROs) at Week 52 of the study compared to baseline

The safety objectives of the study are to:

- Evaluate the safety of BMN 270 during the first 52 weeks following intravenous infusion
- Assess the long-term safety of BMN 270

## 9 INVESTIGATIONAL PLAN

### 9.1 Overall Study Design and Plan

This is a Phase 3, single-arm, open-label study in hemophilia A patients with residual FVIII levels  $\leq 1$  IU/dL treated continuously with prophylactic exogenous FVIII for a minimum of one year prior to enrollment. Subjects will be enrolled at approximately 60 sites worldwide. Subjects must have high-quality, well-documented historical data available concerning previous bleeding episodes and exogenous FVIII usage over the previous 12 months in order to be eligible to enroll in the study.

Approximately 130 adult subjects with severe HA will receive a 6E13 vg/kg dose of BMN 270 as a single intravenous infusion. Approximately 20 subjects will enroll in the study with at least 12 months of well-documented high-quality historical data concerning previous bleeding episodes and exogenous FVIII usage, while approximately 110 subjects will enroll in the study after having completed approximately 6 months' participation in the BioMarin-sponsored non-interventional study 270-902, in which bleeding and FVIII use data prior to gene therapy will be prospectively collected.

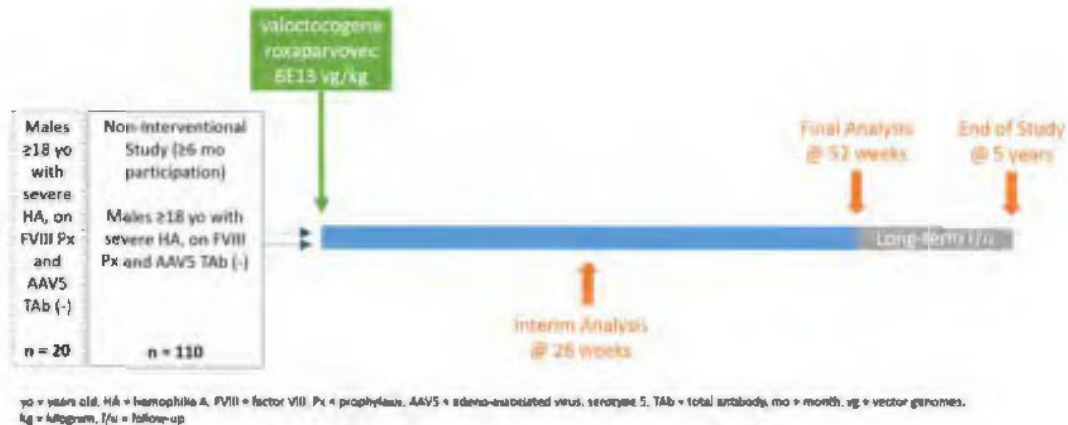

In order to minimize bias in the ongoing study and to assure safe and ethical conduct of the clinical trial, an independent Data Monitoring Committee (DMC), consisting of experts in clinical trials, statistics, and hemophilia, has been convened. The DMC will have sole access during the trial to amalgamated FVIII activity levels, FVIII usage, and bleeding data and will review available safety and efficacy (eg, FVIII activity) data during the study on an ongoing basis; they may determine, based on emerging data and the risk/benefit profile, that further enrollment at 6E13 vg/kg should be discontinued in favor of a different dose of BMN 270, not to exceed 6E13 vg/kg. If the DMC recommends a dosing modification, then additional



---

subjects may be enrolled, up to a total of approximately 130 subjects, at the new BMN 270 dose level (regardless of the number of subjects previously enrolled at 6E13 vg/kg).

An interim analysis is planned after 20 treated HIV-negative subjects have completed the Week 26 visit.

The final analysis for the study will be performed after all subjects have been followed for 52 weeks post-BMN 270 infusion. After the final analysis, safety and efficacy will then continue to be assessed long-term in all subjects for a total of approximately 5 years.

To avoid breakthrough bleeding, subjects will only discontinue exogenous prophylactic FVIII replacement therapy after 4 weeks following infusion of BMN 270. Four weeks represents the time by which endogenous production of FVIII following gene transfer is expected to be efficacious, based on earlier results.

As the relationship between activity assay results of the BMN 270 gene product and bleeding remains to be established, Investigators should strive to minimize bias by avoiding consideration of FVIII activity levels by themselves or subjects in the reporting of bleeding episodes and FVIII usage.

In subjects who experience recurrent bleeding episodes, the Investigator and Medical Monitor will discuss whether to resume prior FVIII prophylaxis.

Subjects who do not respond to BMN 270 treatment (ie, treatment failure, manifesting as either failure to achieve FVIII activity  $\geq 5$  IU/dL by Week 52 or inability to maintain independence from prophylactic FVIII replacement therapy due to joint bleeding episodes, in the judgment of the Investigator) may, at the Investigator's discretion and after discussion with the Medical Monitor or Sponsor-designated Data Monitor, follow an abbreviated visit schedule after Week 52 of the study by attending only the Q12W and End of Year visits during Years 2-5.

There will be an ongoing review of individual subject safety by the Medical Monitor, and both safety and efficacy data by the DMC. Therapeutic oral corticosteroids may be initiated when a subject's ALT values are elevated, and subsequent dosage adjustments made, after consultation between the Investigator and the Medical Monitor. Management of ALT elevations is discussed in more detail in Section 9.7.8.3.

Any safety signal may trigger a review of the data and possible additional immunogenicity studies or other diagnostics deemed necessary that include an assessment of cellular immune responses using collected peripheral blood mononuclear cells (PBMCs).





---

Schedules of assessments for the Screening and Infusion period ([Table 9.1.1](#)), Post-Infusion follow-up periods ([Table 9.1.2](#), [Table 9.1.3](#), [Table 9.1.4](#), [Table 9.1.5](#)), and during the use of oral corticosteroids ([Table 9.1.6](#)) are presented below.



**Table 9.1.1: Schedule of Events – Screening and Infusion**

| Assessment  | Prior to BMN 270 Infusion      |  |  | BMN 270 Infusion Visit (Day 1) <sup>k</sup> |
|---|--------------------------------|--|--|---|
|   | Screening* (Day -28 to Day -1) | Smart Rescreening <sup>i</sup> (Day -28 to Day -1) | Baseline (Day -7 to Day -1) <sup>h</sup> |   |
| Informed consent  | X                              |  |  |   |
| Demographics (age, sex, race, ethnicity)  | X                              |  |  |   |
| Medical History   | X                              |  |  |   |
| Physical Examination <sup>a</sup>   | X                              |  | X  | X   |
| Height and Weight   | X                              |  |  |   |
| Vital Signs   | X                              | X  | X  | X   |
| Assessment of Adverse Events and Concomitant Medications  | X                              | X  | X  | X   |
| Documentation of bleeding episodes and FVIII usage for previous 12 months (by either subject or clinical information) | X                              | X  | X  |   |
| Distribution of subject diaries and training in their use <sup>l</sup>  | X                              |  |  |   |
| Electrocardiogram   | X                              |  |  |   |
| Liver Ultrasound  | X                              |  |  |   |
| hFVIII Assays <sup>b</sup>  | X                              | X <sup>i</sup>                                     | X  |   |
| AAV5 TAb Assays <sup>c</sup>  | X                              | X  | X  | X   |
| AAV5 TI Assay   |                                |  | X  |   |
| Screen for Hepatitis B, Hepatitis C, HIV <sup>d</sup>   | X                              |  |  |   |
| Blood chemistry, hematology, and coagulation tests <sup>e</sup>   | X                              | X  | X  |   |
| Fasting lipid panel (blood triglycerides, total cholesterol, HDL cholesterol, and LDL cholesterol)                    |                                |  |  | X   |
| Urine Tests <sup>e</sup>  | X                              | X  | X  |   |
| Liver Tests <sup>e</sup>  | X                              | X  | X  |   |
| PBMC collection (for baseline determination of AAV5 and FVIII specific cellular immunity)                             |                                |  | X  |   |



| Assessment   | Prior to BMN 270 Infusion      |  |  | BMN 270 Infusion Visit (Day 1) <sup>k</sup> |
|--|--------------------------------|--|--|---|
|  | Screening* (Day -28 to Day -1) | Smart Rescreening <sup>i</sup> (Day -28 to Day -1) | Baseline (Day -7 to Day -1) <sup>h</sup> |   |
| Von Willebrand Factor Antigen (VWF:Ag)                       |                                |  | X  |   |
| TGA Assay <sup>g</sup>                                       |                                |  | X  |   |
| PCR of vector DNA in blood, saliva, urine, semen, and stools |                                |  | X  | X   |
| Biomarker testing <sup>f</sup>                               | X                              |  |  |   |
| Exploratory biomarker assessments <sup>g</sup>               |                                |  | X  | X   |
| Haemo-QOL-A assessment                                       |                                |  | X  |   |
| EQ-5D-5L   |                                |  | X  |   |
| HAL  |                                |  | X  |   |
| WPAI+CIQ:HS  |                                |  | X  |   |
| PROBE  |                                |  | X  |   |
| BMN 270 Infusion   |                                |  |  | X   |
| Hypersensitivity blood assessments <sup>m</sup>              |                                |  |  | X <sup>m</sup>                              |

\* Screening assessments should be performed within 28 days of BMN 270 infusion (and must be performed within 42 days prior to BMN 270 infusion).

<sup>a</sup> Complete physical examination should be done at Screening. Brief physical examination may be done at Baseline and at the BMN 270 Infusion Visit.

<sup>b</sup> Includes baseline FVIII activity (chromogenic substrate FVIII assay and one-stage clotting FVIII assay), coagulation exploratory assay, hFVIII inhibitor level (Bethesda assay with Nijmegen modification), hFVIII total antibody titer, and hFVIII protein assay. Baseline activity should be assessed at trough (at least >72 hours after last dose of replacement FVIII therapy, or 5x the known half-life of the FVIII concentrates administered).

<sup>c</sup> Sample collection on the day of the infusion visit must be performed before the BMN 270 infusion is given. Screening, Smart Re-screening, and Infusion Day samples will be tested in an AAV5 TAB pre-screening assay specifically developed for enrolment purposes. Baseline and all post-dose samples will be tested in a different AAV5 TAB post-dose immunogenicity monitoring assay

<sup>d</sup> Patients with documented negative results within the last 30 days do not need to be retested. Hepatitis B screening should include hepatitis B surface antigen (HBsAg), hepatitis B surface antibody (HBsAb), and hepatitis B core antibody (HBcAb).

<sup>e</sup> Refer to [Table 9.7.8.2.1](#) for laboratory assessments to be included, and to [Table 9.7.8.3.1](#) for liver tests. ABO blood typing assessment should be performed as part of the hematology assessment (at Baseline, or at another regularly scheduled visit prior to the end of the subject's participation in the study).

<sup>f</sup> Includes HLA genotyping and FVIII genotyping.



- 
- <sup>g</sup> Blood samples will be collected to evaluate biochemical, molecular, cellular, and genetic/genomic aspects relevant to hemophilia A, coagulation, and/or AAV gene transfer, and to develop assays used for these evaluations. Subjects may choose to opt out of the exploratory genetic/genomic research being done to study or try to discover genes that are not yet known to be associated with hemophilia A. While exploratory samples will be collected at the time points indicated above, testing of these samples (including those for TGA assay and any other exploratory assessments) will be performed only as deemed necessary by the Sponsor.
- <sup>h</sup> Should the screening visit occur within 30 days of the drug infusion, physical examination, blood chemistry, LTs, hematology, urine tests, and coagulation tests do not need to be repeated at Baseline.
- <sup>i</sup> Smart rescreening should only be performed if a patient has been determined to be eligible for the study and is unable to complete the Baseline assessments and Infusion prior to the closing of the original Screening window. Subjects who undergo smart rescreening must complete the rescreening assessments and receive the infusion within 90 days of signing the original consent. Subjects who do not complete dosing within 90 days will be required to re-consent and undergo all screening procedures. Subjects may not undergo smart rescreening more than once.
- <sup>j</sup> Only the hFVIII inhibitor level (Bethesda assay with Nijmegen modification) assay must be done at smart rescreening.
- <sup>k</sup> With the exception of the collection of samples for PCR vector DNA analysis, assessments on the day of infusion must be performed prior to the infusion. Subjects will fast for at least 8 hours prior to pre-infusion laboratory sampling on the day of the infusion visit. On the day of the BMN 270 Infusion, vital signs will be monitored prior to the infusion, during the infusion every 15 minutes ( $\pm$  5 minutes), and following the infusion hourly ( $\pm$  5 minutes) for at least 8 hours during the subject's stay in the clinic. Shedding samples for PCR of vector DNA analysis (blood, saliva, urine, semen, stool) should be collected between 2 and 24 hours after the infusion has been completed.
- <sup>l</sup> Diaries should be distributed to subjects who have consented to participate in the study and who have been determined to meet all study eligibility criteria.
- <sup>m</sup> In case of hypersensitivity or adverse drug reaction, safety assessment, including physical examination and vital signs, will be done and additional blood samples will be collected within 1 hour of the hypersensitivity reaction (eg, tryptase, C3, C3a, C4, C5, C5a, and cytokine bead array, as well as possible additional exploratory testing) and samples for IgE and cytokine bead array (and possible additional exploratory testing) between 8-24 hours after the reaction, if possible. In addition, a blood sample should be taken 1 week after the hypersensitivity reaction for assessment of the cytokine bead array. In-patient observation can be extended and additional blood samples can be collected if deemed necessary at the discretion of the Investigator and Medical Monitor.

**Table 9.1.2: Schedule of Events – Post-Infusion Follow-Up (Week 1-16)**

| Assessment  | Follow-Up After BMN 270 Infusion – Weeks* |    |    |    |    |                |    |                |    |                |    |                 |    |                 |    |                 |     |
|---|---|----|----|----|----|----------------|----|----------------|----|----------------|----|-----------------|----|-----------------|----|-----------------|-----|
|   | Week 1                                    |    | 2  | 3  | 4  | 5 <sup>g</sup> | 6  | 7 <sup>g</sup> | 8  | 9 <sup>g</sup> | 10 | 11 <sup>g</sup> | 12 | 13 <sup>g</sup> | 14 | 15 <sup>g</sup> | 16  |
|   | D4  | D8 |    |    |    |                |    |                |    |                |    |                 |    |                 |    |                 |     |
| Study Day*  | 4   | 8  | 15 | 22 | 29 | 36             | 43 | 50             | 57 | 64             | 71 | 78              | 85 | 92              | 99 | 106             | 113 |
| Physical examination <sup>a</sup>   |   | X  | X  | X  | X  | X <sup>g</sup> | X  | X <sup>g</sup> | X  | X <sup>g</sup> | X  | X <sup>g</sup>  | X  | X <sup>g</sup>  | X  | X <sup>g</sup>  | X   |
| Weight <sup>a</sup>   |   |    |    |    | X  |                |    |                | X  |                |    |                 | X  |                 |    |                 | X   |
| Assessment of Adverse Events and Concomitant Medications (including review of subject diary for bleeding and FVIII use) |   | X  | X  | X  | X  | X              | X  | X              | X  | X              | X  | X               | X  | X               | X  | X               | X   |
| Vital Signs   |   | X  | X  | X  | X  | X <sup>g</sup> | X  | X <sup>g</sup> | X  | X <sup>g</sup> | X  | X <sup>g</sup>  | X  | X <sup>g</sup>  | X  | X <sup>g</sup>  | X   |
| Blood chemistry, hematology, and coagulation tests <sup>b</sup>   |   |    | X  |    | X  |                |    |                |    |                | X  |                 |    |                 |    |                 | X   |
| Urine Tests <sup>b</sup>  |   |    |    |    |    |                |    |                |    |                |    |                 | X  |                 |    |                 |     |
| Liver Tests <sup>b</sup>  | X   | X  | X  | X  | X  | X              | X  | X              | X  | X              | X  | X               | X  | X               | X  | X               | X   |
| FVIII assays <sup>c</sup>   |   | X  | X  | X  | X  | X              | X  | X              | X  | X              | X  | X               | X  | X               | X  | X               | X   |
| FVIII antibody titer  |   |    |    |    | X  |                |    |                | X  |                |    |                 | X  |                 |    |                 | X   |
| PCR of vector DNA in blood, saliva, urine, semen, and stools <sup>d</sup>   | X   | X  | X  | X  | X  |                | X  |                | X  |                |    |                 | X  |                 |    |                 | X   |
| Exploratory biomarker assessments <sup>e</sup>  |   |    |    |    |    |                | X  |                |    |                |    |                 | X  |                 |    |                 | X   |
| Haemo-QOL-A assessment  |   |    |    |    | X  |                |    |                |    |                |    |                 | X  |                 |    |                 |     |
| EQ-5D-5L  |   |    |    |    | X  |                |    |                |    |                |    |                 | X  |                 |    |                 |     |
| HAL   |   |    |    |    | X  |                |    |                |    |                |    |                 | X  |                 |    |                 |     |



| Assessment  | Follow-Up After BMN 270 Infusion – Weeks* |    |    |    |    |                |    |                |    |                |    |                 |    |                 |    |                 |                |
|---|---|----|----|----|----|----------------|----|----------------|----|----------------|----|-----------------|----|-----------------|----|-----------------|----------------|
|   | Week 1                                    |    | 2  | 3  | 4  | 5 <sup>a</sup> | 6  | 7 <sup>a</sup> | 8  | 9 <sup>a</sup> | 10 | 11 <sup>a</sup> | 12 | 13 <sup>a</sup> | 14 | 15 <sup>a</sup> | 16             |
|   | D4  | D8 |    |    |    |                |    |                |    |                |    |                 |    |                 |    |                 |                |
| Study Day*  | 4   | 8  | 15 | 22 | 29 | 36             | 43 | 50             | 57 | 64             | 71 | 78              | 85 | 92              | 99 | 106             | 113            |
| WPAI+CIQ:HS   |   |    |    |    | X  |                |    |                |    |                |    |                 | X  |                 |    |                 |                |
| PROBE   |   |    |    |    | X  |                |    |                |    |                |    |                 | X  |                 |    |                 |                |
| AAV5 TAb Assay  |   |    |    |    |    |                |    |                | X  |                |    |                 |    |                 |    |                 | X              |
| AAV5 TI Assay   |   |    |    |    |    |                |    |                | X  |                |    |                 |    |                 |    |                 | X              |
| Testing for reactivation of hepatitis B and hepatitis C                 |   |    |    |    |    |                |    |                |    |                |    |                 |    |                 |    |                 | X <sup>f</sup> |
| PBMC collection (for determination of AAV5 and FVIII specific immunity) |   |    | X  |    | X  |                | X  |                | X  |                | X  |                 | X  |                 | X  |                 | X              |
| VWF:Ag  |   |    |    |    |    |                |    |                |    |                |    |                 | X  |                 |    |                 |                |

\* Visit windows are ± 48 hours (and include the Day 4 visit).

<sup>a</sup> Brief physical examination should be done at all weekly visits.

<sup>b</sup> Refer to [Table 9.7.8.2.1](#) for laboratory assessments to be included, and to [Table 9.7.8.3.1](#) for liver tests (LTs). LTs may be monitored more or less frequently (and in particular when ALT values are  $\geq 1.5x$  ULN or  $> ULN$  &  $> 2x$  baseline value) based on discussion between the Medical Monitor and the Investigator and review of subject data, but LTs will be monitored at least twice weekly during periods when a subject's ALT is  $\geq 3x$  ULN. Subjects with ALT  $> 1.5x$  ULN or  $> ULN$  &  $> 2x$  baseline value during the study and either an alternative etiology considered or for further evaluation of the lab abnormality may undergo additional evaluations (eg, imaging studies including MRI or ultrasound, additional blood tests, and/or liver biopsy) at the discretion of the Investigator. Additional testing of FVIII and LTs during any study week may be performed if: (1) the ALT has increased to above ULN; (2) Increases in ALT values from prior assessment are accompanied by declines in FVIII activity level; or after a discussion between the Medical Monitor and the Investigator based on a review of subject data. If FVIII levels and/or ALT values are stable over the course of several weeks, assessment of FVIII activity and ALT levels may be adjusted based on discussion between the Medical Monitor and the Investigator.

<sup>c</sup> Includes FVIII activity level (chromogenic substrate FVIII assay and one-stage clotting FVIII assay), Bethesda assay (with Nijmegen modification) for hFVIII inhibitor level, coagulation exploratory assay, and hFVIII protein assay. If a subject has used FVIII within 72 hours of a measurement day, all efforts should be made to obtain FVIII activity measurements when a 72-hour interval without FVIII use is achieved; the 72-hour wash-out period is only intended for subjects who have achieved FVIII  $\geq 5$  IU/dL at 16 weeks after BMN 270 infusion and who have not resumed FVIII replacement therapy. If FVIII levels are elevated or stable over the course of several weeks, assessment of FVIII activity may be adjusted based on discussion between the Medical Monitor and the Investigator. A D-dimer may be considered under circumstances in which FVIII activity levels are above the normal physiological range and/or if there is a concern for a venous thromboembolism.



- 
- <sup>d</sup> Collection for each matrix to occur until at least 3 consecutive negative results are obtained. Collection and testing of semen samples must continue at least through Week 12, even if 3 consecutive negative results in that compartment have already been recorded.
- <sup>e</sup> Blood samples will be collected to evaluate biochemical, molecular, cellular, and genetic/genomic aspects relevant to hemophilia A, coagulation, and/or AAV gene transfer, and to develop assays used for these evaluations. Subjects may choose to opt out of the exploratory genetic/genomic research being done to study or try to discover genes that are not yet known to be associated with hemophilia A. While exploratory samples will be collected at the time points indicated above, testing of these samples (including those for TGA assay and any other exploratory assessments) will be performed only as deemed necessary by the Sponsor.
- <sup>f</sup> Testing for reactivation of hepatitis B and hepatitis C at Week 16, for subjects with a past medical history of hepatitis B or hepatitis C prior to study entry, should be performed only in subjects who have not received therapeutic oral corticosteroids prior to Week 16; subjects who have received therapeutic oral corticosteroids will have hepatitis B and hepatitis C testing at the time points indicated in [Table 9.1.6](#).
- <sup>g</sup> For subjects who have entered 270-301 following participation in 270-902, the scheduled visits at Week 5, Week 7, Week 9, Week 11, Week 13, and Week 15 may be performed by a mobile nursing (MN) professional at the subject's home or another suitable location (if the subject has given written informed consent to participate in MN visits), or at the site as a shortened lab draw-only visit. The MN service or site will collect blood samples at these visits. For site lab draw-only visits, sites will contact the subject via phone call or e-mail to collect information regarding adverse events, changes to concomitant medications, bleeding episodes, and FVIII use. For MN visits, the service will collect this information. The physical examination and vital signs assessments listed in the Schedule of Events will not be performed at these MN or lab draw-only visits for subjects who have entered 270-301 following participation in 270-902.

**Table 9.1.3: Schedule of Events – Post-Infusion Follow-Up (Week 17-32)**

| Assessment  | Follow-Up After BMN 270 Infusion – Weeks* |     |                 |     |                 |     |                 |     |                 |     |                 |     |                 |                 |                 |     |
|---|---|-----|-----------------|-----|-----------------|-----|-----------------|-----|-----------------|-----|-----------------|-----|-----------------|-----------------|-----------------|-----|
|   | 17 <sup>f</sup>                           | 18  | 19 <sup>f</sup> | 20  | 21 <sup>f</sup> | 22  | 23 <sup>f</sup> | 24  | 25 <sup>f</sup> | 26  | 27 <sup>f</sup> | 28  | 29 <sup>f</sup> | 30 <sup>f</sup> | 31 <sup>f</sup> | 32  |
| Study Day*  | 120                                       | 127 | 134             | 141 | 148             | 155 | 162             | 169 | 176             | 183 | 190             | 197 | 204             | 211             | 218             | 225 |
| Physical examination <sup>a</sup>   | X <sup>f</sup>                            | X   | X <sup>f</sup>  | X   | X <sup>f</sup>  | X   | X <sup>f</sup>  | X   | X <sup>f</sup>  | X   | X <sup>f</sup>  | X   | X <sup>f</sup>  | X <sup>f</sup>  | X <sup>f</sup>  | X   |
| Weight <sup>a</sup>   |   |     |                 | X   |                 |     |                 | X   |                 |     |                 | X   |                 |                 |                 | X   |
| Assessment of Adverse Events and Concomitant Medications (including review of subject diary for bleeding and FVIII use) | X   | X   | X               | X   | X               | X   | X               | X   | X               | X   | X               | X   | X               | X               | X               | X   |
| Vital Signs   | X <sup>f</sup>                            | X   | X <sup>f</sup>  | X   | X <sup>f</sup>  | X   | X <sup>f</sup>  | X   | X <sup>f</sup>  | X   | X <sup>f</sup>  | X   | X <sup>f</sup>  | X <sup>f</sup>  | X <sup>f</sup>  | X   |
| Blood chemistry, hematology, and coagulation tests <sup>b</sup>   |   |     |                 |     |                 | X   |                 |     |                 | X   |                 |     |                 |                 |                 | X   |
| Urine Tests <sup>b</sup>  |   |     |                 |     |                 |     |                 |     |                 | X   |                 |     |                 |                 |                 |     |
| Liver Tests <sup>b</sup>  | X   | X   | X               | X   | X               | X   | X               | X   | X               | X   | X               | X   | X               | X               | X               | X   |
| FVIII assays <sup>c</sup>   | X   | X   | X               | X   | X               | X   | X               | X   | X               | X   | X               | X   | X               | X               | X               | X   |
| FVIII antibody titer  |   |     |                 | X   |                 |     |                 | X   |                 | X   |                 |     |                 |                 |                 | X   |
| PCR of vector DNA in blood, saliva, urine, semen, and stools <sup>d</sup>   |   |     |                 | X   |                 |     |                 | X   |                 | X   |                 |     |                 |                 |                 | X   |
| Exploratory biomarker assessments <sup>c</sup>  |   |     |                 | X   |                 |     |                 | X   |                 | X   |                 |     |                 |                 |                 | X   |



| Assessment   | Follow-Up After BMN 270 Infusion – Weeks* |     |                 |     |                 |     |                 |     |                 |     |                 |     |                 |                 |                 |     |
|--|---|-----|-----------------|-----|-----------------|-----|-----------------|-----|-----------------|-----|-----------------|-----|-----------------|-----------------|-----------------|-----|
|  | 17 <sup>f</sup>                           | 18  | 19 <sup>f</sup> | 20  | 21 <sup>f</sup> | 22  | 23 <sup>f</sup> | 24  | 25 <sup>f</sup> | 26  | 27 <sup>f</sup> | 28  | 29 <sup>f</sup> | 30 <sup>f</sup> | 31 <sup>f</sup> | 32  |
| Study Day*   | 120                                       | 127 | 134             | 141 | 148             | 155 | 162             | 169 | 176             | 183 | 190             | 197 | 204             | 211             | 218             | 225 |
| Haemo-QOL-A assessment   |   |     |                 |     |                 |     |                 |     |                 | X   |                 |     |                 |                 |                 |     |
| EQ-5D-5L   |   |     |                 |     |                 |     |                 |     |                 | X   |                 |     |                 |                 |                 |     |
| HAL  |   |     |                 |     |                 |     |                 |     |                 | X   |                 |     |                 |                 |                 |     |
| WPAI+CIQ:HS  |   |     |                 |     |                 |     |                 |     |                 | X   |                 |     |                 |                 |                 |     |
| PROBE  |   |     |                 |     |                 |     |                 |     |                 | X   |                 |     |                 |                 |                 |     |
| AAV5 TAb Assay   |   |     |                 |     |                 |     |                 | X   |                 |     |                 |     |                 |                 |                 | X   |
| AAV5 TI Assay  |   |     |                 |     |                 |     |                 | X   |                 |     |                 |     |                 |                 |                 | X   |
| PBMC collection (for determination of AAV5 and FVIII specific cellular immunity) |   | X   |                 | X   |                 | X   |                 | X   |                 | X   |                 | X   |                 | X               |                 | X   |
| VWF:Ag   |   |     |                 |     |                 |     |                 |     |                 | X   |                 |     |                 |                 |                 |     |
| TGA Assay <sup>c</sup>   |   |     |                 | X   |                 |     |                 | X   |                 | X   |                 |     |                 |                 |                 | X   |

\* Visit windows are ± 48 hours.

<sup>a</sup> Brief physical examination should be done at all weekly visits except Week 26, where a complete physical examination should be performed. Weight should be recorded at Week 20 and every 4 weeks.

<sup>b</sup> Refer to [Table 9.7.8.2.1](#) for laboratory assessments to be included, and to [Table 9.7.8.3.1](#) for liver tests (LTs). LTs may be monitored more or less frequently (and in particular when ALT values are ≥ 1.5x ULN or > ULN & > 2x baseline value) based on discussion between the Medical Monitor and the Investigator and review of subject data, but LTs will be monitored at least twice weekly during periods when a subject's ALT is ≥ 3x ULN. Subjects with ALT ≥ 1.5x ULN or > ULN & > 2x baseline value during the study and either an alternative etiology considered or for further evaluation of the lab abnormality may undergo additional evaluations (eg, imaging studies including MRI or ultrasound, additional blood tests, and/or liver biopsy) at the discretion of the Investigator. Additional testing of FVIII and LTs during any study week may be performed if: (1) the ALT has increased to above ULN; (2) Increases in ALT values from prior assessment are accompanied by declines in FVIII activity level; or after a discussion between the Medical Monitor and the Investigator based on a review of subject data. If FVIII levels and/or ALT values are stable over the course of several weeks, assessment of FVIII activity and ALT levels may be adjusted based on discussion between the Medical Monitor and the Investigator.





<sup>c</sup> Includes FVIII activity level (chromogenic substrate FVIII assay and one-stage clotting FVIII assay), Bethesda assay (with Nijmegen modification) for hFVIII inhibitor level, coagulation exploratory assay, and hFVIII protein. If a subject has used FVIII within 72 hours of a measurement day, all efforts should be made to obtain FVIII activity measurements when a 72-hour interval without FVIII use is achieved; the 72-hour wash-out period is only intended for subjects who have achieved FVIII  $\geq 5$  IU/dL at 16 weeks after BMN 270 infusion and who have not resumed FVIII replacement therapy. If FVIII levels are elevated or stable over the course of several weeks, assessment of FVIII activity may be adjusted based on discussion between the Medical Monitor and the Investigator. A D-dimer may be considered under circumstances in which FVIII activity levels are above the normal physiological range and/or if there is a concern for a venous thromboembolism.

<sup>d</sup> Collection for each matrix to occur until at least 3 consecutive negative results are obtained.

<sup>e</sup> Blood samples will be collected to evaluate biochemical, molecular, cellular, and genetic/genomic aspects relevant to hemophilia A, coagulation, and/or AAV gene transfer, and to develop assays used for these evaluations. Subjects may choose to opt out of the exploratory genetic/genomic research being done to study or try to discover genes that are not yet known to be associated with hemophilia A. While exploratory samples will be collected at the time points indicated above, testing of these samples (including those for TGA assay and any other exploratory assessments) will be performed only as deemed necessary by the Sponsor.

<sup>f</sup> For subjects who have entered 270-301 following participation in 270-902, the scheduled visits at Week 17, Week 19, Week 21, Week 23, Week 25, Week 27, Week 29, Week 30, and Week 31 may be performed by a mobile nursing (MN) professional at the subject's home or another suitable location (if the subject has given written informed consent to participate in MN visits), or at the site as a shortened lab draw-only visit. The MN service or site will collect blood samples at these visits. For site lab draw-only visits, sites will contact the subject via phone call or e-mail to collect information regarding adverse events, changes to concomitant medications, bleeding episodes, and FVIII use. For MN visits, the service will collect this information. The physical examination and vital signs assessments listed in the Schedule of Events will not be performed at these MN or lab draw-only visits for subjects who have entered 270-301 following participation in 270-902.

**Table 9.1.4: Schedule of Events – Post-Infusion Follow-Up (Week 33 – Week 52)**

| Assessment  | Year 1 – Weeks* |                 |                 |     |                 |     |                 |     |                 |     |                 |     |
|---|-----------------|-----------------|-----------------|-----|-----------------|-----|-----------------|-----|-----------------|-----|-----------------|-----|
|   | 33 <sup>e</sup> | 34 <sup>e</sup> | 35 <sup>e</sup> | 36  | 38 <sup>e</sup> | 40  | 42 <sup>e</sup> | 44  | 46 <sup>e</sup> | 48  | 50 <sup>e</sup> | 52  |
| Study Day*  | 232             | 239             | 246             | 253 | 267             | 281 | 295             | 309 | 323             | 337 | 351             | 365 |
| Physical examination <sup>a</sup>   | X <sup>e</sup>  | X <sup>e</sup>  | X <sup>e</sup>  | X   | X <sup>e</sup>  | X   | X <sup>e</sup>  | X   | X <sup>e</sup>  | X   | X <sup>e</sup>  | X   |
| Weight <sup>a</sup>   |                 |                 |                 | X   |                 | X   |                 | X   |                 | X   |                 | X   |
| Assessment of Adverse Events and Concomitant Medications (including review of subject diary for bleeding and FVIII use) | X               | X               | X               | X   | X               | X   | X               | X   | X               | X   | X               | X   |
| Vital Signs   | X <sup>e</sup>  | X <sup>e</sup>  | X <sup>e</sup>  | X   | X <sup>e</sup>  | X   | X <sup>e</sup>  | X   | X <sup>e</sup>  | X   | X <sup>e</sup>  | X   |
| Blood chemistry, hematology, and coagulation tests <sup>b</sup>   |                 |                 |                 | X   |                 |     |                 | X   |                 |     |                 | X   |
| Urine Tests <sup>b</sup>  |                 |                 |                 | X   |                 |     |                 |     |                 |     |                 | X   |
| Liver Tests <sup>b</sup>  | X               | X               | X               | X   | X               | X   | X               | X   | X               | X   | X               | X   |
| FVIII assays <sup>c</sup>   | X               | X               | X               | X   | X               | X   | X               | X   | X               | X   | X               | X   |
| AAV5 TAb Assay  |                 |                 |                 | X   |                 |     |                 |     |                 |     |                 | X   |
| AAV5 TI Assay   |                 |                 |                 | X   |                 |     |                 |     |                 |     |                 | X   |
| FVIII antibody titer  |                 |                 |                 | X   |                 |     |                 | X   |                 |     |                 | X   |
| Exploratory biomarker assessments <sup>d</sup>  |                 |                 |                 | X   |                 | X   |                 | X   |                 | X   |                 | X   |
| PBMC Collection (for determination of FVIII and Capsid specific cellular immunity)                                      |                 |                 |                 | X   |                 |     |                 | X   |                 |     |                 | X   |
| VWF:Ag  |                 |                 |                 | X   |                 |     |                 |     |                 |     |                 | X   |
| TGA Assay <sup>d</sup>  |                 |                 |                 | X   |                 | X   |                 | X   |                 | X   |                 | X   |
| PCR of vector DNA in blood, saliva, urine, semen, and stools  |                 |                 |                 | X   |                 | X   |                 | X   |                 | X   |                 | X   |
| Haemo-QOL-A assessment  |                 |                 |                 |     |                 |     |                 |     |                 |     |                 | X   |
| EQ-5D-5L  |                 |                 |                 |     |                 |     |                 |     |                 |     |                 | X   |
| HAL   |                 |                 |                 |     |                 |     |                 |     |                 |     |                 | X   |
| WPAI+CIQ:HS   |                 |                 |                 |     |                 |     |                 |     |                 |     |                 | X   |



| Assessment | Year 1 – Weeks* |                 |                 |    |                 |    |                 |    |                 |    |                 |    |
|------------|-----------------|-----------------|-----------------|----|-----------------|----|-----------------|----|-----------------|----|-----------------|----|
|            | 33 <sup>e</sup> | 34 <sup>e</sup> | 35 <sup>e</sup> | 36 | 38 <sup>e</sup> | 40 | 42 <sup>e</sup> | 44 | 46 <sup>e</sup> | 48 | 50 <sup>e</sup> | 52 |
| PROBE      |                 |                 |                 |    |                 |    |                 |    |                 |    |                 | X  |

\* Visit windows are  $\pm$  48 hours through Week 36, then  $\pm$ 1 week until Week 52

<sup>a</sup> Complete physical examination should be performed at Week 52; brief physical exam may be performed at other study visits. Weight should be recorded at Week 36 and every 4 weeks through Week 52.

<sup>b</sup> Refer to [Table 9.7.8.2.1](#) for laboratory assessments to be included, and to [Table 9.7.8.3.1](#) for liver tests. LTs may be monitored more or less frequently (and in particular when ALT values are  $\geq$  1.5x ULN or  $>$  ULN &  $>$  2x baseline value) based on discussion between the Medical Monitor and the Investigator and review of subject data, but LTs will be monitored at least twice weekly during periods when a subject's ALT is  $\geq$  3x ULN. Subjects with ALT  $\geq$  1.5x ULN or  $>$  ULN &  $>$  2x baseline value during the study and either an alternative etiology considered or for further evaluation of the lab abnormality may undergo additional evaluations (eg, imaging studies including MRI or ultrasound, additional blood tests, and/or liver biopsy) at the discretion of the Investigator. Additional testing of FVIII and LTs during any study week may be performed if: (1) the ALT has increased to above ULN or increased by  $>$  10 U/L from prior assessment; (2) Increases in ALT values from prior assessment are accompanied by declines in FVIII activity level; or after a discussion between the Medical Monitor and the Investigator based on a review of subject data. If FVIII levels and/or ALT values are stable over the course of several weeks, assessment of FVIII activity and ALT levels may be adjusted based on discussion between the Medical Monitor and the Investigator.

<sup>c</sup> Includes FVIII activity level (chromogenic substrate FVIII assay and one-stage clotting FVIII assay), Bethesda assay (with Nijmegen modification) for hFVIII inhibitor level, coagulation exploratory assay, and hFVIII protein assay. If a subject has used FVIII within 72 hours of a measurement day, all efforts should be made to obtain FVIII activity measurements when a 72-hour interval without FVIII use is achieved; the 72-hour wash-out period is only intended for subjects who have achieved FVIII  $\geq$  5 IU/dL at 16 weeks after BMN 270 infusion and who have not resumed FVIII replacement therapy. If FVIII levels are elevated or stable over the course of several weeks, assessment of FVIII activity may be adjusted based on discussion between the Medical Monitor and the Investigator. A D-dimer may be considered under circumstances in which FVIII activity levels are above the normal physiological range and/or if there is a concern for a venous thromboembolism.

<sup>d</sup> Blood samples will be collected to evaluate biochemical, molecular, cellular, and genetic/genomic aspects relevant to hemophilia A, coagulation, and/or AAV gene transfer, and to develop assays used for these evaluations. Subjects may choose to opt out of the exploratory genetic/genomic research being done to study or try to discover genes that are not yet known to be associated with hemophilia A. While exploratory samples will be collected at the time points indicated above, testing of these samples (including those for TGA assay and any other exploratory assessments) will be performed only as deemed necessary by the Sponsor.

<sup>e</sup> For subjects who have entered 270-301 following participation in 270-902, the scheduled visits at Week 33, Week 34, Week 35, Week 38, Week 42, Week 46, and Week 50 may be performed by a mobile nursing (MN) professional at the subject's home or another suitable location (if the subject has given written informed consent to participate in MN visits), or at the site as a shortened lab draw-only visit. The MN service or site will collect blood samples at these visits. For site lab draw-only visits, sites will contact the subject via phone call or e-mail to collect information regarding adverse events, changes to concomitant medications, bleeding episodes, and FVIII use. For MN visits, the service will collect this information. The physical examination and vital signs assessments listed in the Schedule of Events will not be performed at these MN or lab draw-only visits for subjects who have entered 270-301 following participation in 270-902.

**Table 9.1.5: Schedule of Events – Post-Infusion Follow-Up (Year 2 – Year 5)**

| Assessment  | Years 2-5*       | Year 2*          | Years 3-5*       | End of Year Visit |                  |                |                | ETV              |
|---|------------------|------------------|------------------|-------------------|------------------|----------------|----------------|------------------|
|   | Q12W             | Q4W <sup>g</sup> | Q6W <sup>g</sup> | Year 2<br>W104    | Year 3<br>W156   | Year 4<br>W208 | Year 5<br>W260 |                  |
| Study Week*   |                  |                  |                  |                   |                  |                |                |                  |
| Physical examination <sup>a</sup>   | X <sup>a</sup>   |                  |                  |                   | X <sup>a</sup>   |                |                | X                |
| Weight <sup>a</sup>   | X <sup>a</sup>   |                  |                  |                   | X <sup>a</sup>   |                |                | X                |
| Assessment of Adverse Events and Concomitant Medications (including review of subject diary for bleeding and FVIII use) | X                | X                | X                |                   | X                |                |                | X                |
| Vital Signs   | X                |                  |                  |                   | X                |                |                | X                |
| Blood chemistry, hematology, and coagulation tests <sup>b</sup>   | X <sup>b</sup>   |                  |                  |                   | X <sup>b</sup>   |                |                | X                |
| Urine Tests <sup>b</sup>  | X <sup>b</sup>   |                  |                  |                   | X <sup>b</sup>   |                |                | X                |
| Liver Tests <sup>b</sup>  | X                | X                | X                |                   | X                |                |                | X                |
| FVIII assays <sup>c</sup>   | X                | X                | X                |                   | X                |                |                | X                |
| AAV5 TAb Assay  | X                |                  |                  |                   | X                |                |                | X                |
| AAV5 TI Assay   | X                |                  |                  |                   | X                |                |                | X                |
| FVIII antibody titer  | X                |                  |                  |                   | X                |                |                | X                |
| Exploratory biomarker assessments <sup>e</sup>  | X                |                  |                  |                   | X                |                |                | X                |
| PBMC Collection (for determination of FVIII and Capsid specific cellular immunity)                                      | X                |                  |                  |                   | X                |                |                | X                |
| VWF:Ag  | X                |                  |                  |                   | X                |                |                | X                |
| TGA Assay <sup>c</sup>  | X                |                  |                  |                   | X                |                |                | X                |
| PCR of vector DNA in blood, saliva, urine, semen, and stools <sup>d</sup>   | (X) <sup>d</sup> | (X) <sup>d</sup> | (X) <sup>d</sup> |                   | (X) <sup>d</sup> |                |                | (X) <sup>d</sup> |
| Haemo-QOL-A assessment  | X <sup>f</sup>   |                  |                  |                   | X <sup>f</sup>   |                |                | X                |
| EQ-5D-5L  | X <sup>f</sup>   |                  |                  |                   | X <sup>f</sup>   |                |                | X                |
| HAL   | X <sup>f</sup>   |                  |                  |                   | X <sup>f</sup>   |                |                | X                |
| WPAI+CIQ:HS   | X <sup>f</sup>   |                  |                  |                   | X <sup>f</sup>   |                |                | X                |



| Assessment  | Years 2-5*     | Year 2*          | Years 3-5*       | End of Year Visit |                |                |                | ETV |
|-------------|----------------|------------------|------------------|-------------------|----------------|----------------|----------------|-----|
|             | Q12W           | Q4W <sup>g</sup> | Q6W <sup>g</sup> | Year 2<br>W104    | Year 3<br>W156 | Year 4<br>W208 | Year 5<br>W260 |     |
| Study Week* |                |                  |                  |                   |                |                |                |     |
| PROBE       | X <sup>f</sup> |                  |                  | X <sup>f</sup>    |                |                |                | X   |

\* Visit windows are  $\pm 2$  weeks for visits in Years 2-5. At applicable sites, the Q4W (during Year 2) and Q6W (during Years 3-5) assessments may be conducted by a trained mobile nursing (MN) professional at the subject's home or another suitable location, if the subject has given written informed consent to participate in mobile nursing visits. Q12W and End of Year visits during Years 2-5 cannot be done by a MN professional and must be done at the study site.

<sup>a</sup> Complete physical examination should be performed at the End of Year visits; brief physical exam may be performed at other study visits. Weight should be recorded at the second Q12W visit each year and at every End of Year visit during Years 2-5.

<sup>b</sup> Refer to [Table 9.7.8.2.1](#) for laboratory assessments to be included, and to [Table 9.7.8.3.1](#) for liver tests. LTs may be monitored more or less frequently (and in particular when ALT values are  $\geq 1.5x$  ULN or  $> ULN$  &  $> 2x$  baseline value) based on discussion between the Medical Monitor and the Investigator and review of subject data, but LTs will be monitored at least twice weekly during periods when a subject's ALT is  $\geq 3x$  ULN. Subjects with ALT  $\geq 1.5x$  ULN or  $> ULN$  &  $> 2x$  baseline value during the study and either an alternative etiology considered or for further evaluation of the lab abnormality may undergo additional evaluations (eg, imaging studies including MRI or ultrasound, additional blood tests, and/or liver biopsy) at the discretion of the Investigator. Additional testing of FVIII and LTs during any study week may be performed if: (1) the ALT has increased to above ULN or increased by  $> 10$  U/L from prior assessment; (2) Increases in ALT values from prior assessment are accompanied by declines in FVIII activity level; or after a discussion between the Medical Monitor and the Investigator based on a review of subject data. If FVIII levels and/or ALT values are stable over the course of several weeks, assessment of FVIII activity and ALT levels may be adjusted based on discussion between the Medical Monitor and the Investigator. During Years 2-5 of the Post-Infusion Follow-Up period, urine tests and blood, chemistry, and coagulation tests should be performed at the second Q12W visit each year and at every End of Year visit.

<sup>c</sup> Includes FVIII activity level (chromogenic substrate FVIII assay and one-stage clotting FVIII assay), Bethesda assay (with Nijmegen modification) for hFVIII inhibitor level, coagulation exploratory assay, and hFVIII protein assay. If a subject has used FVIII within 72 hours of a measurement day, all efforts should be made to obtain FVIII activity measurements when a 72-hour interval without FVIII use is achieved; the 72-hour wash-out period is only intended for subjects who have achieved FVIII  $\geq 5$  IU/dL at 16 weeks after BMN 270 infusion and who have not resumed FVIII replacement therapy. If FVIII levels are elevated or stable over the course of several weeks, assessment of FVIII activity may be adjusted based on discussion between the Medical Monitor and the Investigator. A D-dimer may be considered under circumstances in which FVIII activity levels are above the normal physiological range and/or if there is a concern for a venous thromboembolism. If a subject tests positive in the Bethesda assay (with Nijmegen modification) during Years 3-5, a fresh sample should be collected within 4 weeks of the initial visit that had a positive result.

<sup>d</sup> Sample testing during Long-Term Follow-Up is not required if at least 3 consecutive samples were negative during the Post-Infusion Follow-Up period. Subjects who have not had 3 consecutive negative semen samples by Week 52 should continue to have PCR testing of semen every 4 weeks (during Year 2) or every 6 weeks (during Years 3-5) until 3 consecutive negative samples are documented (or upon consultation between the Investigator and Medical Monitor).

<sup>e</sup> Blood samples will be collected to evaluate biochemical, molecular, cellular, and genetic/genomic aspects relevant to hemophilia A, coagulation, and/or AAV gene transfer, and to develop assays used for these evaluations. Subjects may choose to opt out of the exploratory genetic/genomic research being done to study or try to discover genes that are not yet known to be associated with hemophilia A. While exploratory samples will be collected at the time points indicated above, testing of these samples (including those for TGA assay and any other exploratory assessments) will be performed only as deemed necessary by the Sponsor.



---

<sup>f</sup> PRO assessments during Years 2-5 of Long-Term Follow-up should be performed at the second Q12W visit each year and at every End of Year visit.

<sup>g</sup> Subjects who meet the definition of treatment failure to BMN 270 therapy after Week 52 may omit the Q4W and Q6W visits during Years 2-5, and must attend only the Q12W and End of Year visits. Such subjects following the abbreviated schedule who have not yet cleared vector shedding in all fluids must still provide samples Q4W (during Year 2) or Q6W (during Years 3-5) until vector shedding has been cleared, either by reporting to the site to provide samples or by providing those samples to a MN professional.

**Table 9.1.6: Schedule of Events – Therapeutic Corticosteroids for ALT Elevations**

|   | Steroid Treatment Period <sup>b</sup> |        |        |        |        |        |        |                     | Post-Steroid Period <sup>c</sup> |        |        |        |         |
|---|---------------------------------------|--------|--------|--------|--------|--------|--------|---------------------|----------------------------------|--------|--------|--------|---------|
|   | Week 1                                | Week 2 | Week 3 | Week 4 | Week 5 | Week 6 | Week 7 | Week 8 <sup>b</sup> | Week 1                           | Week 2 | Week 3 | Week 4 | Week 13 |
| Therapeutic corticosteroids (dose in mg/day) <sup>a</sup> | 60 mg                                 | 60 mg  | 40 mg  | 40 mg  | 40 mg  | 30 mg  | 20 mg  | 10 mg               |                                  |        |        |        |         |
| FVIII activity testing                                    |                                       |        |        |        |        |        |        |                     | X                                | X      | X      | X      |         |
| Liver tests   |                                       |        |        |        |        |        |        |                     | X                                | X      | X      | X      |         |
| Hepatitis B testing <sup>d</sup>                          |                                       |        |        |        |        | X      |        |                     | X                                |        |        |        | X       |
| HCV Viral Load <sup>d</sup>                               |                                       |        |        |        |        | X      |        |                     | X                                |        |        |        | X       |

<sup>a</sup> Therapeutic oral corticosteroids may be initiated according to the parameters set out in Section 9.4.8.2.

<sup>b</sup> Following initiation or completion of steroid regimen, if a recurrence of ALT values  $\geq 1.5x$  ULN or  $> ULN$  &  $> 2x$  baseline value is reported, steroid management decisions will be based on discussions between the Investigator and Medical Monitor. Modification of the steroid regimen may take into consideration possible confounders for the ALT elevation, relationship between increases in ALT and FVIII activity, ALT/FVIII levels post steroid initiation, and adverse events related to steroid dosing. Guidance for tapering oral corticosteroid dosing can be found in Section 9.4.8.2.

<sup>c</sup> After discontinuation of oral corticosteroids, weekly labs for ALT and FVIII levels will be measured once a week for 4 weeks to ensure stability in values. If these assessments are already being done as part of normal study follow-up, they do not need to be duplicated.

<sup>d</sup> Should only be performed in subjects with a history of hepatitis B or hepatitis C prior to study entry.



## 9.2 Discussion of Study Design, Including Choice of Control Group

Study 270-301 is designed to be a Phase 3, single-arm, open-label study in hemophilia A patients with residual FVIII levels  $\leq 1$  IU/dL previously treated with prophylactic exogenous FVIII. Hemophilia A patients who provide written informed consent, meet the entry criteria definition of residual FVIII activity, have well-documented historical data for the previous 12 months concerning exogenous FVIII usage and bleeding episodes, and do not have antibodies to AAV5 will be eligible to enroll in the study.

Approximately 130 subjects will be enrolled at the 6E13 vg/kg BMN 270 dose. Subjects will be followed for 52 weeks post-BMN 270 infusion during which safety and efficacy assessments will be taken. After the final analysis at 52 weeks post-infusion, safety and efficacy will then continue to be assessed long-term for approximately a total of 5 years. During enrollment, the DMC will review available safety and efficacy data on an ongoing basis and may decide to recommend dosing subjects at a different dose level (not to exceed 6E13 vg/kg) based on emerging data from 270-301 and their overall benefit:risk assessment.

Study 270-301 is a self-controlled study. Parameters for each subject will be compared to a pre-treatment assessment of safety (liver function) and efficacy (number of bleeds, use of FVIII replacement therapy).

## 9.3 Selection of Study Population

Approximately 130 adult hemophilia A patients with residual FVIII levels  $\leq 1$  IU/dL may enroll into the study.

Additional criteria for participation in the study are provided in Section 9.3.1 and Section 9.3.2.

### 9.3.1 Inclusion Criteria

Individuals eligible to participate in this study must meet all of the following inclusion criteria:

1. Males  $\geq 18$  years of age with hemophilia A and residual FVIII levels  $\leq 1$  IU/dL as evidenced by medical history, at the time of signing the informed consent.
2. Must have been on prophylactic FVIII replacement therapy for at least 12 months prior to study entry. High-quality, well-documented historical data concerning bleeding episodes and FVIII usage over the previous 12 months must be available.
3. Treated/exposed to FVIII concentrates or cryoprecipitate for a minimum of 150 exposure days (EDs).





4. Willing and able to provide written, signed informed consent after the nature of the study has been explained and prior to any study-related procedures.
5. No previous documented history of a detectable FVIII inhibitor, and results from a Bethesda assay or Bethesda assay with Nijmegen modification of less than 0.6 Bethesda Units (BU) (or less than 1.0 BU for laboratories with a historical lower sensitivity cutoff for inhibitor detection of 1.0 BU) on 2 consecutive occasions at least one week apart within the past 12 months (at least one of which should be tested at the central laboratory).
6. Sexually active participants must agree to use an acceptable method of effective contraception, either double-barrier contraception (ie, condom + diaphragm; or condom or diaphragm + spermicidal gel or foam) or their female partner either using hormonal contraceptives or having an intrauterine device. Participants must agree to contraception use for at least 12 weeks post-infusion; after 12 weeks, subjects may stop contraception use only if they have had 3 consecutive semen samples with no detectable viral vector DNA.
7. Willing to abstain from alcohol consumption for at least the first 52 weeks following BMN 270 infusion.

### 9.3.2 Exclusion Criteria

Individuals who meet any of the following exclusion criteria will not be eligible to participate in the study:

1. Detectable pre-existing antibodies to the AAV5 capsid.
2. Any evidence of active infection or any immunosuppressive disorder, including HIV infection.
3. Significant liver dysfunction with any of the following abnormal laboratory results:
  - ALT (alanine aminotransferase) > 1.25x ULN;
  - AST (aspartate aminotransferase) > 1.25x ULN;
  - GGT (gamma-glutamyltransferase) > 1.25x ULN;
  - Total bilirubin > 1.25x ULN;
  - Alkaline phosphatase > 1.25x ULN; or
  - INR (international normalized ratio)  $\geq$  1.4.

Subjects whose liver laboratory assessments fall outside of these ranges may undergo repeat testing of the entire liver test panel within the same Screening window and, if eligibility criteria are met on retest, may be enrolled after confirmation by the Medical Monitor.



4. Prior liver biopsy showing significant fibrosis of 3 or 4 as rated on a scale of 0-4 on the Batts-Ludwig (Batts, 1995) or METAVIR (Bedossa, 1996) scoring systems, or an equivalent grade of fibrosis if an alternative scale is used.
5. Evidence of any bleeding disorder not related to hemophilia A.
6. Platelet count of  $< 100 \times 10^9/L$ .
7. Creatinine  $\geq 1.5$  mg/dL.
8. Liver cirrhosis of any etiology as assessed by liver ultrasound.
9. Chronic or active hepatitis B as evidenced by positive serology testing (HBsAg, HBsAb, and HBcAb) and confirmatory HBV DNA testing. Refer to the Centers for Disease Control (CDC) table for the interpretation of serological test results in the Laboratory Manual.
10. Active Hepatitis C as evidenced by detectable HCV RNA or currently on antiviral therapy.
11. Active malignancy, except non-melanoma skin cancer.
12. History of hepatic malignancy.
13. History of arterial or venous thromboembolic events (eg, deep vein thrombosis, non-hemorrhagic stroke, pulmonary embolism, myocardial infarction, arterial embolus), with the exception of catheter-associated thrombosis for which anti-thrombotic treatment is not currently ongoing.
14. Known inherited or acquired thrombophilia, including conditions associated with increased thromboembolic risk, such as atrial fibrillation.
15. Treatment with any investigational product within 30 days or 5 half-lives of the investigational product prior to the screening period. For subjects who have received a prior investigational product, all ongoing adverse events (AEs) experienced while receiving that investigational product must have resolved prior to screening for this study.
16. Any condition that, in the opinion of the Investigator or Sponsor would prevent the patient from fully complying with the requirements of the study (including possible corticosteroid treatment outlined in the protocol) and/or would impact or interfere with evaluation and interpretation of subject safety or efficacy result.
17. Prior treatment with any vector or gene transfer agent.
18. Major surgery planned in the 52-week period following the infusion with BMN 270.
19. Use of systemic immunosuppressive agents, not including corticosteroids, or live vaccines within 30 days before the BMN 270 infusion.



20. Concurrent enrollment in another clinical study, unless it is an observational (non-interventional) clinical study that does not interfere with the requirements of the current protocol or have the potential to impact the evaluation of efficacy and safety of BMN 270 and with prior consultation with the Medical Monitor.
21. Known allergy or hypersensitivity to BMN 270 investigational product formulation.
22. Unwilling to receive blood or blood products for treatment of an adverse event and/or a bleeding episode.

### **9.3.3 Removal of Subjects from Treatment or Assessment**

Subjects may withdraw their consent to participate in the study at any time without prejudice. The Investigator must withdraw from the study any subject who requests to be withdrawn. Such subjects will always be asked about the reason(s) for withdrawal. The Investigator will discuss with the subject appropriate procedures for withdrawal from the study. The Investigator should ask the subject's consent to perform the procedures listed under the early termination visit. Should a subject withdraw from the study, all efforts will be made to complete and report the observations as thoroughly as possible up to the date of the withdrawal.

A subject's participation in the study may be discontinued at any time at the discretion of BioMarin or of the Investigator and in accordance with his/her clinical judgment. When possible, the tests and evaluations listed for the termination visit should be carried out and every effort will be made to gather follow-up safety data if possible.

BioMarin must be notified of all subject withdrawals as soon as possible. BioMarin also reserves the right to discontinue the study at any time for either clinical or administrative reasons and to discontinue participation by an individual Investigator or site for poor enrollment or noncompliance.

Reasons for which the Investigator or BioMarin may withdraw a subject from the study include, but are not limited to, the following:

- Subject requires medication or medical procedure prohibited by the protocol
- Subject does not adhere to study requirements specified in the protocol
- Subject was erroneously enrolled into the study or does not meet entry criteria and not yet been dosed with BMN 270; subjects who do not meet entry criteria but who erroneously receive BMN 270 should remain in the study for safety monitoring
- Subject is lost to follow-up

If a subject fails to return for scheduled visits, a documented effort must be made to determine the reason. If the subject cannot be reached by telephone, a certified letter should



be sent to the subject requesting contact with the Investigator. This information should be recorded in the study records.

The Investigator or designee must explain to each subject, before enrollment into the study, that for evaluation of study results, the subject's protected health information obtained during the study may be shared with the study Sponsor, regulatory agencies, and IRB/IEC/REB. It is the Investigator's (or designee's) responsibility to obtain written permission to use protected health information per country-specific regulations, such as the Health Insurance Portability and Accountability Act (HIPAA) in the US, from each subject. If permission to use protected health information is withdrawn, it is the Investigator's responsibility to obtain a written request, to ensure that no further data will be collected from the subject and the subject will be removed from the study.

#### 9.3.3.1 Study Safety Evaluation Criteria

If any of the following events occur in a subject in the study who has received BMN 270 infusion, an urgent evaluation by the DMC will be required and further enrollment into the trial will be temporarily put on hold if recommended by the DMC per Section 9.1.

1. Liver dysfunction (criteria do not apply to ALT elevations with an extra-hepatic etiology):
  - ALT > 5x ULN, for more than 2 weeks
  - ALT > 3x ULN **and** (total bilirubin > 2x ULN **or** INR >1.5)
  - ALT > 3x ULN with signs and symptoms of liver dysfunction
2. The occurrence of Grade 4 or Grade 5 adverse events assessed as related to study drug (events of liver dysfunction are defined above).
3. The occurrence of an AE of hepatic failure.
4. The detection of high-titer neutralizing antibodies (>5 BU) to hFVIII following BMN 270 infusion in two subjects.
5. The occurrence of any cancer (except non-melanoma skin cancer) at any point after BMN 270 infusion.
6. The occurrence of a thromboembolic event with FVIII activity > 150 IU/dL in one subject.

If any of the following events occurs in a subject in the study who has received BMN 270 infusion, an urgent evaluation by the DMC will be required. Further enrollment into the trial will continue while DMC evaluation is ongoing, unless deemed otherwise by the DMC:

1. The detection of high-titer neutralizing antibodies (>5 BU) to hFVIII following BMN 270 infusion in one subject.



2. Occurrence of a thromboembolic event in one subject.

### **9.3.4 Subject Identification and Replacement of Subjects**

Each subject will be assigned a unique subject identifier. This unique identifier will be on all eCRF pages. In legal jurisdictions where use of initials is not permitted, a substitute identifier will be used.

Subjects who withdraw from the study after receiving BMN 270 will not be replaced.

### **9.3.5 Duration of Subject Participation**

The duration of participation for each subject will be approximately 264 weeks. This includes 4 weeks of screening, 1 day of BMN 270 infusion, 52 weeks of Post-Infusion Follow-Up, and 208 weeks of Long-Term Follow-Up.

## **9.4 Treatments**

### **9.4.1 Treatments Administered**

BioMarin and/or its designee will provide the study site with a supply of IP sufficient for the completion of the study. BioMarin is responsible for shipping study drug to clinical sites.

### **9.4.2 Identity of Investigational Product**

#### **9.4.2.1 Product Characteristics and Labeling**

BMN 270 is a sterile, clear, colorless-to-pale yellow solution for IV infusion and is supplied in a 10 mL Crystal Zenith® (CZ) vial. Each vial contains 8.5 mL (extractable volume 8 mL) of AAV5-hFVIII-SQ at a concentration of 2E13 vector genomes per mL in a pH 7.4 phosphate buffer.

The study drug is labelled according to the particulars approved by the relevant regulatory agencies.

#### **9.4.3 Storage**

At the study site, all IP must be stored under the conditions specified in the Pharmacy Manual in a secure area accessible only to the designated pharmacists and clinical site personnel. All IP must be stored and inventoried and the inventories must be carefully and accurately documented according to applicable state, federal and local regulations, ICH GCP, and study procedures.



#### 9.4.4 Directions for Administration

On the day of infusion, the subject will come to the infusion site, where a physical examination will be performed by the Investigator or designee. If the subject is found to have an active acute illness at the time of planned infusion, then the infusion should be deferred until the illness has resolved; screening procedures may require repetition if outside the specified window. An IV catheter or butterfly needle will be inserted into a suitable peripheral vein (eg, the median cubital vein) and flushed with saline. FVIII replacement therapy will not be given since venipuncture is a minimally invasive procedure in these individuals under ordinary conditions.

BMN 270 will be prepared and infused as a pure solution over a dose-dependent time. Prepared drug will be kept at room temperature prior to administration. An electric syringe pump will be used to infuse through an in-line, low protein binding 0.22 micron filter. BMN 270 will be infused through the catheter using an appropriate infusion pump at an initial rate of 1 mL/min. The infusion rate should be increased every 30 minutes by 1 mL/min up to a maximum of 4 mL/min, provided that the subject's clinical condition permits such an increase. Of note, the IP has been shown to be stable at room temperature for 7.5 hours following completion of product thaw. Vital signs (pulse, blood pressure, respiration rate and temperature) should be monitored at 15 minute ( $\pm 5$  minutes) intervals throughout the time period of the infusion.

As with any infused biological product, there is a potential risk of acute, systemic hypersensitivity reactions (including anaphylaxis) with BMN 270. Dosing will be administered at a qualified infusion site, with appropriate resuscitation equipment and medication available and easily accessible.

Clinical staff administering BMN 270 should be trained appropriately in recognizing and managing the signs and symptoms associated with potential hypersensitivity, anaphylactic, and anaphylactoid reactions. Additionally, the Investigator should be familiar with Sampson's criteria for defining anaphylaxis (Sampson, 2006; Appendix 1).

Should symptoms of potential hypersensitivity occur, the infusion may be slowed or halted at the Investigator's discretion, with consideration of the subject's clinical condition. If the infusion is halted, it should only be restarted if the Investigator considers it safe and appropriate to do so. Antihistamines, anti-pyretic, and/or corticosteroid administration is permitted prior to restarting an interrupted infusion by an infusion-related reaction. At the restart, the infusion rate may be adjusted (ie, to a slower rate [minimum of 1 mL/min], with



the rate increased every 30 minutes by 1 mL/min up to a maximum rate of 4 mL/min, if the subject's clinical condition permits such an increase) with careful monitoring of the subject.

In case of hypersensitivity or adverse drug reaction, safety assessment, including physical examination and vital signs, will be done and additional blood samples will be collected within 1 hour of the hypersensitivity reaction (eg, tryptase, C3, C3a, C4, C5, C5a, and cytokine bead array, as well as possible additional exploratory testing) and samples for IgE and cytokine bead array (and possible additional exploratory testing) between 8-24 hours after the reaction, if possible. In addition, a blood sample should be taken 1 week after the hypersensitivity reaction for assessment of the cytokine bead array. In-patient observation can be extended and additional blood samples can be collected if deemed necessary at the discretion of the Investigator and Medical Monitor.

Following completion of the infusion, vital signs will be monitored hourly ( $\pm$  5 minutes). If the vital signs are stable the catheter will be removed 8 hours after the infusion. Hemostasis at the puncture site will be established by applying pressure according to standard protocol for infusing FVIII concentrates. Subjects will remain in the clinic for at least 8 hours to observe for any immediate toxicity of the procedure; in-patient observation can be extended beyond 8 hours if needed per Investigator discretion, or the subject may transfer to a separate facility based on the evaluation and judgment of the Principal Investigator after consultation with the Medical Monitor.

Prior to discharging subjects from the clinic, the Investigator or designee should instruct subjects how to recognize signs and symptoms of potential (delayed) hypersensitivity reactions and anaphylaxis, and to contact a medical practitioner or seek emergency care in case of such an event.

#### **9.4.5 Method of Assigning Subjects to Treatment Groups**

Subjects who meet all eligibility criteria (refer to Section 9.3.1 and Section 9.3.2) may be enrolled into the study. Approval by the Medical Monitor will be required prior to enrollment of each study subject. Upon their enrollment into the study, subjects will be assigned a unique subject number.

Approximately 130 subjects will be enrolled at 6E13 vg/kg.

#### **9.4.6 Selection of Dose Used in the Study**

Data from an ongoing first in human study (Clinical Study 270-201) indicates that following single escalated doses of BMN 270 (6E12, 2E13, 4E13, 6E13 vg/kg), dose-related increases in FVIII activity were observed, with concurrent improvements in bleeding episodes and





exogenous FVIII utilization, particularly at the 4E13 and 6E13 vg/kg dose levels. At all dose levels, BMN 270 is considered to be well-tolerated with mild increases in ALT as the most common adverse event. Please refer to the IB for detailed efficacy and safety data.

In order to further evaluate the dose-response relationship of BMN 270, subjects will be enrolled at a dose of 6E13 vg/kg. This dose is expected to be safe and effective based on clinical experience to date in 270-201. The DMC will review emerging safety and efficacy data and may recommend that a different dose (not to exceed 6E13 vg/kg) be administered. In such a case, up to 130 additional subjects may be enrolled at the new dose.

#### **9.4.7 Blinding**

This is an open-label study.

#### **9.4.8 Prior and Concomitant Medications**

All prescription and over-the-counter medications (including dietary and herbal supplements) taken by a subject for 30 days before Screening will be recorded on the designated eCRF. The Investigator may prescribe additional medications, deemed necessary to provide adequate prophylactic or supportive care, during the study, as long as the prescribed medication is not prohibited by the protocol. In the event of an emergency, any needed medications may be prescribed without prior approval, but the Medical Monitor must be notified of the use of any contraindicated medications immediately thereafter. Any concomitant medications added or discontinued during the study should be recorded on the eCRF. Medications should, whenever possible, not be recorded in the electronic database with a frequency of PRN.

The following medications are prohibited starting 30 days before Screening and through the end of the study, and the Sponsor must be notified if a subject receives any of these during the study:

- Any investigational therapy
- Systemic immunosuppressive agents, except for corticosteroids
- Emicizumab
- Fitusiran
- Concizumab
- Efavirenz
- Lamivudine





The following medications should be avoided, starting 30 days prior to and for at least 52 weeks after BMN 270 infusion and minimized throughout the remaining duration of the study.

- Alcohol
- Herbal and natural remedies and dietary supplements
- Medications which may be hepatotoxic

Vaccines should also be avoided during this period, but in particular during the first 26 weeks unless clinically indicated.

The following medications should be avoided during oral corticosteroid therapy:

- Vaccines
- NSAIDs

#### **9.4.8.1 Concomitant Hemophilia Treatments**

Subjects on prophylactic FVIII therapy will discontinue their regular treatment regimen starting 4 weeks after the day of infusion and switch to an “on-demand” schedule. FVIII replacement therapy can always be taken as needed by the subject for treatment of an acute bleeding episode; the subject must carefully record his treatment and bleeding episodes in his diary. Prophylactic FVIII use can be used on a case-by-case basis and in consultation with the Medical Monitor to prevent bleeding in extenuating circumstances (eg, peri-operative).

In addition, information on FVIII usage and bleeding episodes by medical history must be well-documented and available and will be collected from subjects for the 12-month period immediately preceding study enrollment. Further information on the details that should be provided as part of the subject’s well-documented medical and FVIII usage history are provided in the On Site File Binder.

In order to enable rigorous comparisons of pre-study versus on-study FVIII usage and bleeding episodes, the Medical Monitor will review each screened patient’s prior bleed and hemophilia medication logs to determine if they are of "high-quality". Elements that will be assessed to judge the quality of such historical data may include, but are not limited to, the following:

- Date, type (eg, joint, muscle, other), location of bleeds
- Date, name, dose (calculated in IU/kg), and reason for use (eg, usual prophylaxis, one-time prophylaxis, treatment for bleed, surgery) of hemophilia medications.



### 9.4.8.2 Therapeutic Glucocorticoid Treatment of Elevated Hepatic Transaminases

Therapeutic oral corticosteroids (prednisone or converted equivalent) should be initiated when either of the following occurs post-BMN 270 infusion in any subject and after consultation with the Medical Monitor (or their designee):

- ALT  $\geq 1.5x$  ULN or ALT  $> ULN$  &  $> 2x$  baseline value in 2 consecutive assessments within 72 hours and alternative etiologies have been ruled out, or ALT  $\geq 3x$  ULN in 2 consecutive assessments within 48 hours (refer to [Table 9.7.8.3.2](#))
  - Whenever possible, a confirmatory lab draw for ALT should be performed, along with FVIII activity, prior to initiating oral corticosteroids.
  - Corticosteroids may be delayed if elevations in ALT are clearly not related to BMN 270 (eg, elevated ALT with concurrent increase in CPK due to intensive exercise)

The prescribed regimen for therapeutic oral corticosteroids is detailed in [Table 9.1.6](#).

Changes to the corticosteroid regimen should be made as follows:

**Table 9.4.8.2.1: Adjustments to Corticosteroid Regimen**

|   |   |   |
|---|---|---|
| <b>Tapering<br/>Corticosteroid<br/>Dose</b>   | Subject has been receiving oral corticosteroids <3 weeks  | Corticosteroids may be discontinued <b>if</b> : <ul style="list-style-type: none"> <li>• ALT <math>&lt; 1.5x</math> ULN or ALT <math>\leq ULN</math> &amp; <math>\leq 2x</math> baseline value; and</li> <li>• FVIII levels <math>&gt; 20</math> IU/dL and within 10% of the pre-decline FVIII levels; and</li> <li>• There is no concern for adrenal insufficiency post-withdrawal</li> </ul>            |
|   | Subject has been receiving oral corticosteroids $\geq 3$ weeks  | Corticosteroids may be tapered by 10 mg weekly <b>if</b> : <ul style="list-style-type: none"> <li>• ALT <math>&lt; 1.5x</math> ULN or ALT <math>\leq ULN</math> &amp; <math>\leq 2x</math> baseline value; and</li> <li>• FVIII levels <math>&gt; 20</math> IU/dL and within 10% of the pre-decline FVIII levels; and</li> <li>• There is no concern for adrenal insufficiency post-withdrawal</li> </ul> |
| <b>Increasing<br/>Corticosteroid<br/>Dose</b> | If ALT level is increasing or FVIII level is decreasing while on oral corticosteroids, any increases in oral corticosteroid dosing should be made only upon consultation with the Medical Monitor |   |

For any scenarios that are not accounted for in the above table, a discussion should take place between the Investigator and Medical Monitor regarding corticosteroid dose adjustments.

After discontinuation of oral corticosteroids, labs for ALT and FVIII levels will be measured once a week for 4 weeks to ensure stability in values.

Following initiation or completion of therapeutic oral corticosteroids, if ALT elevation  $\geq 1.5x$  ULN or ALT  $\geq ULN$  &  $\geq 2x$  baseline value is reported, corticosteroid management decisions will be based on discussions between the Investigator and Medical Monitor.



Modification of the corticosteroid regimen may take into consideration possible confounders for the ALT elevation and impact on FVIII expression.

Management and monitoring of reactions to corticosteroids should be determined by the Investigator's clinical judgment in consultation with the Sponsor's Medical Monitor. This includes the contraindicated use of NSAIDs during corticosteroid treatment and specific monitoring not already covered by the schedule of events. The use of COX-2 inhibitors, while not contraindicated during corticosteroid treatment, should be limited, if possible. Practical management to prevent complications related to oral corticosteroid therapy may be undertaken at the discretion of the Investigator (eg, evaluation of glucose intolerance, hyperlipidemia etc.). Hepatitis B status and HCV viral load will be rechecked 6 weeks after the start of oral corticosteroid treatment and then 1 week and 13 weeks after the completion of oral corticosteroid treatment in subjects with a history of hepatitis B or hepatitis C. All adverse events (including any adverse events suspected to be caused by or related to corticosteroid use) should be reported as outlined in Section 10 of the protocol.

#### **9.4.8.3 Monitoring of HIV-Positive Subjects**

HIV-positive subjects who have previously enrolled in 270-301 should continue anti-retroviral therapy (ART) as prescribed and follow routine monitoring of CD4 count and viral load ([US Dept Health Human Services, 2014](#)). No alterations in the monitoring are indicated for enrolled immunocompetent HIV-positive subjects who receive corticosteroids as part of their enrollment in 270-301.

#### **9.4.9 Treatment Compliance**

Study drug will be administered to subjects at the study site and/or the dosing facility by a qualified health care professional. The quantity dispensed, returned, used, lost, etc. must be recorded on a dispensing log. Sites will be instructed to return or destroy all used and unused study drug containers.

### **9.5 Investigational Product Accountability**

The Investigator or designee is responsible for maintaining accurate records (including dates and quantities) of IP(s) received and IP lost or accidentally or deliberately destroyed. The Investigator or designee must retain all unused or expired study supplies until the study monitor (on-site CRA) has confirmed the accountability data, if allowed by local SOPs.

#### **9.5.1 Return and Disposition of Clinical Supplies**

Unused study drug must be kept in a secure location for accountability and reconciliation by the study monitor. The Investigator or designee must provide an explanation for any



destroyed or missing study drug or study materials (or must be referenced in their institution SOPs).

Unused study drug may be destroyed on site, per the site's standard operating procedures, but only after BioMarin has granted approval for drug destruction. The monitor must account for all study drug in a formal reconciliation process prior to study drug destruction. All study drug destroyed on site must be documented. Documentation must be provided to BioMarin or designee and retained in the Investigator study files. If a site is unable to destroy study drug appropriately, the site can return unused study drug to BioMarin upon request. The return of study drug or study drug materials must be accounted for on a study drug return form provided by BioMarin.

All study drug and related materials should be stored, inventoried, reconciled, and destroyed or returned according to applicable state and federal regulations and study procedures. For additional information, please refer to the Pharmacy Manual.

## **9.6 Dietary or Other Protocol Restrictions**

There are no dietary or other protocol restrictions for this study. Alcohol should be avoided for the first 52 weeks of the study, and particularly within 48 hours prior to lab work.

Subjects should be advised to abstain from any blood or sperm donation after BMN 270 infusion, until there is no further evidence of vector shedding from PCR analysis of samples.

## **9.7 Safety and Efficacy Variables**

### **9.7.1 Safety and Efficacy Measurements Assessed**

The Schedule of Events ([Table 9.1.1](#) through [Table 9.1.5](#)) describes the timing of required evaluations.

### **9.7.2 Primary Efficacy Variables**

#### **9.7.2.1 FVIII Activity**

The primary efficacy variable is change of the hFVIII activity, as measured by chromogenic substrate assay, during Weeks 49-52 post-BMN 270 infusion from baseline. Each subject's hFVIII activity during Weeks 49-52 is defined as the median of the values obtained during this 4-week window. Values for FVIII activity will be excluded if obtained within 72 hours since the last infusion of exogenous FVIII protein concentrates.

If a subject has used FVIII within 72 hours of a measurement day, all efforts should be made to obtain FVIII activity measurements when a 72-hour interval without FVIII use is achieved; The 72-hour wash-out period is only intended for subjects who have achieved



FVIII  $\geq$  5 IU/dL at 16 weeks after BMN 270 infusion and who have not resumed FVIII replacement therapy.

In the event of an FVIII activity level decline during the study:

- If FVIII activity has declined at least 20% from the peak but less than 35% and has declined for at least 2 consecutive assessments, FVIII activity and LTs should be repeated every 7 days until FVIII activity is stable or increasing
- If FVIII activity has declined  $>35\%$  from the peak and has declined for at least 2 consecutive assessments, FVIII activity and LTs should be repeated every 72 hours until FVIII activity is stable or increasing

Note that fluctuations in FVIII activity are common, and if no clear trend indicating a decline in FVIII activity is observed, then this additional testing may be deferred (upon consultation between the Investigator and the Medical Monitor) until either a more clear trend of decline has been demonstrated or until the FVIII activity levels stabilize or increase.

Subjects who do not respond to BMN 270 treatment (ie treatment failure, manifesting as either failure to achieve FVIII activity  $\geq$  5 IU/dL by Week 52 or inability to maintain independence from prophylactic FVIII replacement therapy due to joint bleeding episodes, in the judgment of the Investigator) may, at the Investigator's discretion and after discussion with the Medical Monitor or Sponsor-designated Data Monitor, follow an abbreviated visit schedule after Week 52 of the study by attending only the Q12W and End of Year visits during Years 2-5.

Details on collecting FVIII activity samples are included in the Laboratory Manual.

### **9.7.3 Secondary Efficacy Variables**

#### **9.7.3.1 Factor VIII Replacement Therapy/Bleeding Episodes**

Secondary efficacy variables are:

- Change of the annualized utilization (IU/kg) of exogenous FVIII replacement therapy during Week 5 to Week 52 post BMN 270 infusion from the baseline utilization of exogenous FVIII replacement therapy.
- Change in the annualized number of bleeding episodes requiring exogenous FVIII replacement treatment during Week 5 to Week 52 of the study post BMN 270 infusion from the baseline ABR.

Subjects must have high quality documented historical data available concerning previous bleeding episodes and exogenous FVIII usage over the previous 12 months in order to be eligible to enroll in the study. During the study, subjects will be asked at each study visit to report the use of factor replacement therapy and the number of bleeding episodes since the



previous visit. This information will be captured on the subject's diary or other subject records.

Subjects are strongly encouraged to immediately consult Investigator for guidance regarding exogenous FVIII administration for suspected bleeds or bleeding episodes within the first 30 days post BMN 270 infusion.

In subjects who experience recurrent bleeding episodes, the Investigator and Medical Monitor will discuss whether to resume prior FVIII prophylaxis.

#### **9.7.4 Tertiary Efficacy Variables**

##### **9.7.4.1 Patient-Reported Outcomes (PRO)**

The Haemo-QoL-A questionnaire is a validated hemophilia-specific health-related quality of life questionnaire for adults ([Rentz, 2008](#)). It consists of 41 questions covering six domains (Physical Functioning, Role Functioning, Worry, Consequences of Bleeding, Emotional Impact and Treatment Concerns). Items are answered on a 6-point Likert-type scale, ranging from 0 (None of the time) to 5 (All of the time). Higher scores mean better health-related quality of life or less impairment for a particular subscale ([Haemo-QoL Study Group, 2017](#)). Details regarding the Haemo-QoL-A assessment will be included in the On Site File Binder.

The EQ-5D-5L instrument is a self-reported questionnaire designed to measure general health status ([The EuroQol Group, 1990](#)) ([Brooks, 1996](#)). The EQ-5D-5L is composed of 2-parts: a descriptive system that assesses 5 levels of perceived problems (mobility, self-care, usual activities, pain/discomfort, and anxiety/depression) in 5 dimensions and the EQ visual analogue scale (EQ VAS) assessment for overall health. A sample copy of the EQ-5D-5L and additional information are provided in the On Site File Binder.

The Haemophilia Activities List (HAL) measures the impact of hemophilia on self-perceived functional abilities in adults ([Van Genderen, 2006](#)). The instrument consists of multiple domains including lying/sitting/kneeling/standing, leg and arm function, use of transportation, self-care, household tasks, and leisure activities where subjects are asked to rate their level of difficulty with activities of daily living on a 6-point Likert-type scale from 1 (Impossible) to 6 (Never). For some items, subjects are given the choice to answer 'Not applicable'. A sample copy of the HAL and additional information are provided in the On Site File Binder.

The Work Productivity and Activity Impairment plus Classroom Impairment Questions: Hemophilia Specific (WPAI+CIQ:HS) instrument is designed to measure the effect of disease symptom severity on work productivity and classroom productivity (if applicable)





(Recht, 2014). The WPAI+CIQ:HS questionnaire yields scores related to work/classroom absenteeism, reduced on-the-job effectiveness, overall work/classroom impairment, and activity impairment. WPAI+CIQ:HS outcomes are expressed as impairment percentages, with higher numbers indicating greater impairment and less productivity (Reilly, 2002). A sample copy of the WPAI+CIQ:HS and additional information are provided in the On Site File Binder.

The Patient Reported Outcomes, Burdens, and Experiences (PROBE) questionnaire is designed to investigate and directly probe patient perspectives on outcomes they deem relevant to their life and care. PROBE aims to develop a new global tool to enhance the direct patient-voice in health care decision-making (Chai-Adisaksopha, 2017). A sample copy of the PROBE questionnaire and additional information are provided in the On Site File Binder.

### 9.7.5 Immunogenicity

Immunogenicity assays will be performed on plasma and PBMCs. The assays will include detection of anti-AAV5 capsid and anti-FVIII total antibodies, as well as determination of neutralizing antibodies against FVIII (FVIII inhibitors) and against the AAV5 capsid (Transduction Inhibitors, TI). FVIII Inhibitors will be assessed using the Bethesda assay with Nijmegen modification. Any abnormality of the liver parameters will lead to a retrospective immunogenicity assessment to evaluate FVIII- and capsid-specific cellular immunogenicity. FVIII- and capsid-specific cellular immunity will be assessed by stimulated cytokine secretion using an ELISpot assay performed on collected PBMCs.

### 9.7.6 Pharmacodynamics

The FVIII protein concentration and activity level as measured by a validated immunoassay and by a validated FVIII activity assay, respectively, will be used for plasma profiles; FVIII protein and activity will be used to determine PD parameters.

### 9.7.7 Exploratory Assessments

Blood samples will be collected from subjects at the time points indicated in [Table 9.1.1](#), [Table 9.1.2](#), [Table 9.1.3](#), [Table 9.1.4](#), and [Table 9.1.5](#) to evaluate biochemical, molecular, cellular, and genetic/genomic aspects relevant to hemophilia A, coagulation, and/or AAV gene transfer, and to develop assays used for these evaluations. Subjects may choose to opt out of the exploratory genetic/genomic research being done to study or try to discover genes that are not yet known to be associated with hemophilia A.



All biomarker samples collected in this study may be used for exploratory biomarker research, including evaluation of additional biomarkers not specifically listed in the protocol. In addition, samples collected for other purposes in this study may be used for exploratory research once testing for the primary purpose has been completed.

### **9.7.8 Safety Variables**

Safety in this study will be determined from evaluation of AEs, clinical laboratory assessments with a particular attention to the liver function, vital signs assessments, physical examinations, and immunogenicity.

#### **9.7.8.1 Adverse Events**

The determination, evaluation and reporting of AEs will be performed as outlined in Section 10.

#### **9.7.8.2 Clinical Laboratory Assessments**

The scheduled clinical laboratory tests are listed in [Table 9.7.8.2.1](#). Refer to the On Site File Binder for instructions on obtaining and shipping samples.

Any abnormal test results determined to be clinically significant by the Investigator should be repeated (at the Investigator's discretion) until: (1) the cause of the abnormality is determined; (2) the value returns to baseline or to within normal limits; or (3) the Investigator determines that the abnormal value is no longer clinically significant.

All abnormal clinical laboratory results should be initialed and dated by an Investigator, along with a comment regarding whether or not the result is clinically significant. Each clinically significant laboratory result should be recorded as an adverse event.

The diagnosis, if known, associated with abnormalities in clinical laboratory tests that are considered clinically significant by the Investigator will be recorded on the AE eCRF.



**Table 9.7.8.2.1: Clinical Laboratory Tests**

| <b>Blood Chemistry</b> | <b>Hematology</b>         | <b>Urine Tests</b> | <b>Coagulation Screen including:</b> |
|------------------------|---------------------------|--------------------|--------------------------------------|
| Albumin                | Hemoglobin                | Appearance         | APTT                                 |
| BUN                    | Hematocrit                | Color              | PT/INR                               |
| Calcium                | WBC count                 | pH                 | TT                                   |
| Chloride               | RBC count                 | Specific gravity   |                                      |
| Total cholesterol      | Platelet count            | Ketones            |                                      |
| CPK                    | Differential cell count   | Protein            |                                      |
| Creatinine             | RBC indices (MCV and MCH) | Glucose            |                                      |
| CRP                    | ABO blood typing*         | Bilirubin          |                                      |
| Glucose                |                           | Nitrite            |                                      |
| Phosphorus             |                           | Urobilinogen       |                                      |
| Potassium              |                           | Hemoglobin         |                                      |
| Total protein          |                           |                    |                                      |
| Sodium                 |                           |                    |                                      |
| Uric Acid              |                           |                    |                                      |

BUN, blood urea nitrogen; CPK, creatinine phosphokinase; CRP, C-reactive protein; PT, prothrombin time; APTT, activated partial thromboplastin time; RBC, red blood cell; WBC, white blood cell; TT, thrombin time; INR, international normalized ratio; MCV, mean corpuscular volume; MCH, mean corpuscular hemoglobin.

\*ABO blood typing assessment should be performed as part of the hematology assessment (at Baseline, or at another regularly scheduled visit prior to the end of the subject's participation in the study).

In addition to scheduled clinical laboratory assessments, a fasting blood lipid panel (including triglycerides, total cholesterol, HDL cholesterol, and LDL cholesterol) will be assessed at the BMN 270 infusion visit. Subjects will fast for at least 8 hours prior to pre-infusion laboratory sampling on the day of the infusion visit.

In case of hypersensitivity or adverse drug reaction, safety assessment, including physical examination and vital signs, will be done and additional blood samples will be collected within 1 hour of the hypersensitivity reaction (eg, tryptase, C3, C3a, C4, C5, C5a, and cytokine bead array, as well as possible additional exploratory testing) and samples for IgE and cytokine bead array (and possible additional exploratory testing) between 8-24 hours after the reaction. In addition, a blood sample should be taken 1 week after the hypersensitivity reaction for assessment of the cytokine bead array.

During Years 2-5, at applicable sites, certain study assessments may be performed by a mobile nursing (MN) professional at the patient's home or another suitable location, such as



their school or office, to improve access and convenience for patients participating in the study. The Sponsor may select a healthcare company that will be responsible for providing MN services for participating sites (the MN vendor). The MN vendor is responsible for ensuring that all MN professionals are licensed, qualified, and in good standing, as per applicable regulations, and that appropriate background checks have been performed. If the investigator at a participating site determines that MN services are appropriate for a patient and the patient gives written informed consent to participate in MN visits, the MN network will communicate with the patient and the patient's site. MN visits will be allowed for the Q4W (during Year 2) and Q6W (during Years 3-5) visits; the Q12W visits and End of Year visits during Years 2-5 will not be performed by an MN professional but will be done at the study site.

For subjects who have enrolled in 270-301 following participation in 270-902, MN visits may also be available during Year 1 at Weeks 5, 7, 9, 11, 13, 15, 17, 19, 21, 23, 25, 27, 29, 30, 31, 33, 34, 35, 38, 42, 46, and 50 (as indicated in the Schedule of Events).

### **9.7.8.3 Liver and Hepatitis Testing**

Subjects will be screened for evidence of previous or active hepatitis B or hepatitis C infection at Screening; hepatitis B screening should include HBsAg, HBsAb, and HBcAb. Subjects with documented results showing an absence of active hepatitis B or hepatitis C infection (as measured by positive surface antigen for hepatitis B or positive RNA testing for hepatitis C) 30 days prior to providing signed informed consent do not need to repeat those tests during the screening period.

Evidence of ongoing hepatitis B or hepatitis C infection is exclusionary. Subjects with a history of hepatitis B or hepatitis C infection prior to study entry will be tested for hepatitis B and hepatitis C reactivation at Week 16. Subjects with a history of hepatitis B or hepatitis C will be asked for information about the treatments received as part of their medical history assessment at Screening.

Subjects with a previous history of hepatitis B or hepatitis C who receive therapeutic oral corticosteroids prior to Week 16 do not need to complete the Week 16 reactivation assessment; instead, they will be tested for hepatitis B and hepatitis C reactivation at the time points listed in [Table 9.1.6](#).

A liver ultrasound and liver tests (LTs) during Screening will identify any significant hepatic dysfunction.

LTs will be monitored on a regular basis; at each time point, the following LTs should be assessed:

**Table 9.7.8.3.1: Liver Tests**

| <b>Liver Tests (LTs)</b> |                  |                 |     |
|--------------------------|------------------|-----------------|-----|
| Alkaline Phosphatase     | AST (SGOT)       | Total Bilirubin | LDH |
| ALT (SGPT)               | Direct Bilirubin | GGT             |     |

ALT, alanine aminotransferase; AST, aspartate aminotransferase; GGT, gamma-glutamyltransferase; LDH, lactate dehydrogenase; SGOT, serum glutamic-oxaloacetic transaminase; SGPT, serum glutamic-pyruvic transaminase

Elevated ALT levels (above the upper limit of normal range) should be evaluated according to the following plan:

**Table 9.7.8.3.2: Evaluation of ALT Elevations**

| ALT Level               | Work-Up   |
|-------------------------|---|
| Above ULN and <1.5x ULN | <ul style="list-style-type: none"> <li>• Continue to monitor LTs and FVIII per protocol (repeat within 7 days if next protocol scheduled visit is &gt;7 days from the time of the reported ALT elevation)</li> <li>• Consider evaluation to rule out alternative etiology (eg, concomitant medications, viral or autoimmune hepatitis, alcohol use, recreational drug use, special diets, strenuous exercise, prior and/or concurrent illnesses, exposure to environmental and/or industrial chemicals, etc.) (refer to <a href="#">Table 9.7.8.3.3</a>)</li> <li>• If ALT is &gt; ULN &amp; &gt; 2x baseline in 2 consecutive assessments within 72 hours and alternative etiologies have been ruled out, start oral corticosteroids upon consultation with the Medical Monitor (refer to <a href="#">Section 9.4.8.2</a>)</li> </ul>  |
| 1.5 - <3x ULN           | <ul style="list-style-type: none"> <li>• Repeat LTs and FVIII within 72 hours</li> <li>• Continue to monitor LTs weekly until ALT is stable or improving</li> <li>• Evaluate and rule out alternative etiologies (as above)</li> <li>• Consult with Medical Monitor</li> <li>• If ALT is <math>\geq 1.5x</math> ULN in 2 consecutive assessments within 72 hours and alternative etiologies have been ruled out, start oral corticosteroids (refer to <a href="#">Section 9.4.8.2</a>)</li> </ul>   |
| $\geq 3x$ ULN           | <ul style="list-style-type: none"> <li>• Consult with Medical Monitor</li> <li>• Evaluate and rule out alternative etiologies (as above)</li> <li>• Repeat LTs and FVIII within 48 hours, and continue with monitoring of LTs at least twice weekly for as long as the subject's ALT remains <math>\geq 3x</math> ULN</li> <li>• If <math>\geq 3x</math> ULN in 2 consecutive assessments within 48 hours, start oral corticosteroids (refer to <a href="#">Section 9.4.8.2</a>)</li> <li>• Obtain other possibly relevant laboratory evaluations (albumin, PT/INR, CRP, etc.)</li> <li>• Obtain complete blood count with differential to assess for eosinophilia</li> <li>• Obtain PBMC to evaluate potential immune response (prior to starting oral corticosteroids)</li> <li>• If no improvement in 14 days, consider gastroenterology and/or hepatology consult, abdominal workup, imaging (including MRI or ultrasound), and/or liver biopsy as appropriate</li> </ul> |



When ruling out alternative viral or autoimmune hepatitis as part of the elevated ALT workup, the following tests should be performed:

**Table 9.7.8.3.3: Viral and Autoimmune Hepatitis Testing**

| <b>Viral Hepatitis Workup Testing</b> | <b>Autoimmune Hepatitis Workup Testing</b> |
|---------------------------------------|--|
| Hepatitis A                           | Smooth muscle antibody                     |
| Hepatitis B                           | Mitochondrial antibody                     |
| Hepatitis C                           | Liver/kidney microsomal antibodies         |
| Hepatitis E                           | Antinuclear antibody (ANA) HEP-2           |
| Cytomegalovirus (CMV)                 |  |
| Epstein-Barr virus (EBV)              |  |
| Herpes simplex virus (HSV) 1 & 2      |  |

#### **9.7.8.4 HIV Testing**

HIV testing will be performed at Screening. Subjects with documented negative results within the last 30 days prior to screening do not need to be retested.

#### **9.7.8.5 Vital Signs, Physical Examinations and Other Observations Related to Safety**

Vital signs will include seated systolic and diastolic blood pressure, heart rate, respiration rate, and temperature. Any clinically significant change in vital signs will be recorded as an AE.

Systolic blood pressure, diastolic blood pressure, heart rate, respiration rate, and temperature will be assessed at Screening, Baseline, and at the beginning of each visit during the Post-Infusion Follow-Up and Long-Term Follow-Up periods. On the day of the BMN 270 Infusion, vital signs will be monitored prior to infusion, during the infusion every 15 minutes ( $\pm$  5 minutes), following the infusion hourly ( $\pm$  5 minutes) for at least 8 hours during the subject's stay in the clinic. Any abnormal vital sign assessments should be repeated, and both values should be recorded in the eCRF.

A complete physical examination is necessary during Screening/Baseline, at Week 26 and 52 and every 52 weeks thereafter; at other visits, brief physical examinations may be performed at the discretion of the Investigator based on the subject's clinical condition. Particular attention should be given to signs of bleeding, as well as assessing possible hemarthroses. During Year 1, at visits where the MN services are used or shortened lab draw-only visits are conducted at the sites, the physical examination and vital signs assessments indicated in the Schedule of Events will not be performed.



A complete physical examination will include general appearance (head, eyes, ears, nose, and throat), cardiovascular, dermatologic, lymphatic, respiratory, gastrointestinal, genitourinary, musculoskeletal, and neurologic systems.

A brief physical examination will include general appearance, cardiovascular, dermatologic, respiratory, gastrointestinal, musculoskeletal, and neurologic assessments.

Height will be recorded at Screening only. Weight will be recorded at Screening and then every 4 weeks thereafter through Week 52, and at the second Q12W visit each year and at every End of Year visit during Years 2-5.

#### **9.7.8.6 Vector Shedding**

During the Post-Infusion Follow-Up period, subjects will undergo testing of various bodily samples to look for evidence of vector shedding for possible viral transmission. Bodily fluids will be tested by polymerase chain reaction (PCR). Fluids tested will include:

- Blood
- Saliva
- Semen
- Urine
- Stool

Vector shedding will also be extensively studied in the present clinical trial, at the time points indicated in [Table 9.1.1](#), [Table 9.1.2](#), [Table 9.1.3](#), [Table 9.1.4](#), and [Table 9.1.5](#). Testing will continue until at least 3 consecutive negative results are obtained. Testing of semen will continue at least through Week 12, even if 3 consecutive negative results have been recorded in that compartment prior to that time point. Subjects who have not had 3 consecutive negative semen samples by Week 52 should continue to have PCR testing in semen every 4 weeks (during Year 2) and every 6 weeks (during Years 3-5) until 3 consecutive negative samples are documented (or upon consultation between the Investigator and Medical Monitor). Subjects who meet the definition of treatment failure and wish to follow an abbreviated schedule (refer to [Section 12.7](#)) but who have not cleared vector shedding from all fluids must still provide samples for assessment every 4 weeks (during Year 2) or every 6 weeks (during Years 3-5) until vector shedding has cleared. Such subjects may provide samples on the designated study visit dates either at the sites or through use of a MN professional. Samples may be fractionated prior to shedding analysis in order to better characterize the presence, structure, and location of vector DNA and/or vector capsid within each matrix. If needed, the fractionation may be performed with samples collected



---

specifically for shedding analysis (saliva, blood, semen, urine, feces). Alternatively, the vector DNA characterization during shedding analysis may utilize already fractionated exploratory samples obtained from the above biofluids, such as exploratory plasma samples, exploratory PBMC samples, and red blood cells recovered during PBMC/plasma isolations.

Fractionation of semen to collect purified sperm separately from non-sperm cells may be performed in parallel at any visit where semen samples are collected. The shedding analysis of a fractionated semen sample will only be performed if vector DNA was detected in the whole semen sample for the same visit. Fractionation of semen during shedding analysis may be stopped if purified sperm tested positive for vector DNA on at least three visits, or if purified sperm tested negative for vector DNA on at least three consecutive visits.

Contraception use may need to be extended beyond 26 weeks in individual subjects based on observed vector shedding in semen. After 26 weeks, subjects may stop contraception use only if they have had 3 consecutive negative semen samples (upon consultation between the Investigator and Medical Monitor).

Details for sample collection and storage are provided in the Laboratory Manual.



---

## 10 REPORTING ADVERSE EVENTS

### 10.1 Safety Parameters and Definitions

Safety assessments will consist of monitoring and recording protocol-defined AEs and SAEs; measurement of protocol-specified hematology, clinical chemistry, and urinalysis variables; measurement of protocol-specified vital signs; and other protocol-defined events of special interest that are deemed critical to the safety evaluation of the study drug.

#### 10.1.1 Adverse Events

For this protocol, an adverse event (AE) is any untoward medical occurrence in a subject, temporally associated with the use of study intervention, whether or not considered related to the study intervention.

An AE can therefore be any unfavorable and unintended sign (including an abnormal laboratory finding), symptom, or disease (new or exacerbated) temporally associated with the use of study intervention.

Events meeting the AE definition include:

- Exacerbation of a chronic or intermittent pre-existing condition including either an increase in frequency and/or intensity of the condition.
- New conditions detected or diagnosed after study intervention administration even though it may have been present before the start of the study.
- Signs, symptoms, or the clinical sequelae of a suspected drug-drug interaction.

Events not meeting the AE definition include:

- Any clinically significant abnormal laboratory findings or other abnormal safety assessments which are associated with the underlying disease, unless judged by the investigator to be more severe than expected for the subject's condition.
- The disease/disorder being studied or expected progression, signs, or symptoms of the disease/disorder being studied, unless more severe than expected for the subject's condition.
- Medical or surgical procedure (eg, endoscopy, appendectomy): the condition that leads to the procedure is the AE.
- Situations in which an untoward medical occurrence did not occur (social and/or convenience admission to a hospital).
- Anticipated day-to-day fluctuations of pre-existing disease(s) or condition(s) present or detected at the start of the study that do not worsen.





### 10.1.1.1 Bleeding and Suspected Bleeding Events

All bleeding events and suspected bleeding events, regardless of the need for exogenous FVIII therapy as treatment, should be captured in subject diaries and recorded on the designated bleeding eCRF. Bleeding events and suspected bleeding events should not be reported as adverse events, with the following exception:

- All bleeding events and suspected bleeding events which meet one or more of the criteria for being serious (refer to Section 10.2) should be reported as serious adverse events (whether or not they are bleeding events that are normal sequelae of hemophilia, and whether or not they required exogenous FVIII as treatment).

### 10.2 Serious Adverse Events

A serious adverse event (SAE) is any untoward medical occurrence that, at any dose:

- Results in death
- Is life-threatening

*Note: Life-threatening refers to an event in which the subject was at risk of death at the time of the event. It does not refer to an event, which hypothetically might have caused death, if it were more severe.*

- Requires inpatient hospitalization or prolongation of existing hospitalization

Note: In general, hospitalization signifies that the subject has been detained (usually involving at least an overnight stay) at the hospital or emergency ward for observation and/or treatment that would not have been appropriate in the physician's office or outpatient setting. If the investigational product preparation, infusion, and post-infusion observation period require transfer to an inpatient setting for completion, in the absence of an AE, this will not be considered an SAE.

Complications that occur during hospitalization are AEs. If a complication prolongs hospitalization, the event is serious.

Hospitalization for elective treatment of a pre-existing condition that did not worsen from baseline is not considered an AE.

- Results in persistent or significant disability or incapacity
- Is a congenital anomaly or birth defect in the child or fetus of a subject exposed to IP prior to conception or during pregnancy
- Is an important medical event or reaction – that, based on medical judgment, may jeopardize the subject or require medical/surgical intervention to prevent one of the other outcomes listed above (eg, anaphylaxis)



### **10.2.1 Events of Special Interest (EOSI)**

The following EOSI need to be reported to the Sponsor within 24 hours of site awareness, irrespective of seriousness, severity or causality:

- Elevation of ALT  $\geq 1.5x$  ULN or ALT  $> ULN$  &  $>2x$  baseline value, regardless of whether that elevation triggers an initiation or modification of oral corticosteroid treatment
- Thromboembolic event
- Systemic hypersensitivity, anaphylactic, or anaphylactoid reactions (refer to Appendix 1)
- Development of anti-FVIII inhibitory antibodies (inhibitors)

### **10.3 Methods and Timing for Capturing and Assessing Safety Parameters**

#### **10.3.1 Adverse Event Reporting Period**

The study AE reporting period is as follows:

- After informed consent but prior to initiation of study drug, only SAEs associated with any protocol-imposed interventions will be collected. AEs occurring during this time period should be recorded on the Medical History eCRF.
- After informed consent is obtained and following infusion of study drug, the reporting period for all non-serious AEs and SAEs begins and continues for approximately 5 years or until study discontinuation/termination, whichever is longer.

The criteria for determining, and the reporting of SAEs is provided in Section 10.2.

#### **10.3.2 Eliciting Adverse Events**

Care will be taken not to introduce bias when detecting AEs and/or SAEs. Open-ended and non-leading verbal questioning of the subject is the preferred method to inquire about AE occurrences. The Investigator will record all relevant AE/SAE/EOSI information in the subject's medical record and AE Case Report Form (eCRF).

#### **10.3.3 Assessment of Seriousness, Severity, and Causality**

The Investigator responsible for the care of the subject or medically qualified designee will assess AEs for severity, relationship to study drug, and seriousness (refer to Section 10.2 for SAE definitions). These assessments must be made by a study clinician with the training and authority to make a diagnosis (eg, MD/DO, physician's assistant, nurse practitioner, or DDS).



### 10.3.3.1 Seriousness

The Investigator will assess if an AE should be classified as “serious” based on the seriousness criteria enumerated in Section 10.2. Seriousness serves as a guide for defining regulatory reporting obligations.

### 10.3.3.2 Severity

Severity (as in mild, moderate, or severe headache) is not equivalent to seriousness, which is based on subject/event outcome or action criteria usually associated with events that pose a threat to a subject’s life or functioning. The Investigator will determine the severity of each AE, SAE and EOSI using the NCI CTCAE v4.03. Adverse events that do not have a corresponding CTCAE term will be assessed according to the general guidelines for grading used in the CTCAE v4.03 as stated in Table 10.3.3.2.1.

**Table 10.3.3.2.1: Adverse Event Grading (Severity) Scale**

| Grade | Description  |   |
|-------|--|---|
| 1     | Mild: asymptomatic or mild symptoms; clinical or diagnostic observations only; intervention not indicated  |   |
| 2     | Moderate: minimal, local or noninvasive intervention indicated; limiting age-appropriate instrumental activities of daily living (ADL) <sup>a</sup>                                |   |
| 3     | Severe or medically significant but not immediately life-threatening: hospitalization or prolongation of hospitalization indicated; disabling; limiting self-care ADL <sup>b</sup> |   |
| 4     | Life threatening consequences; urgent intervention indicated   | Grade 4 and 5 AEs should always be reported as SAEs |
| 5     | Death related to AE  |   |

<sup>a</sup> Instrumental ADL refer to the following examples: preparing meals, shopping for groceries or clothes, using the telephone, managing money.

<sup>b</sup> Self-care ADL refer to the following examples: bathing, dressing and undressing, feeding oneself, using the toilet, taking medications, not bedridden.

### 10.3.3.3 Causality

The Investigator will determine the relationship of an AE to the study drug and will record it on the source documents and AE eCRF. To ensure consistency of causality assessments, Investigators should apply the guidance in Table 10.3.3.3.1.

**Table 10.3.3.3.1: Causality Attribution Guidance**

| Relationship | Description  |
|--------------|--|
| Not Related  | <ul style="list-style-type: none"> <li>• Exposure to the IP has not occurred</li> </ul> <p style="text-align: center;"><b>OR</b></p> <ul style="list-style-type: none"> <li>• The administration of the IP and the occurrence of the AE are not reasonably related in time</li> </ul> <p style="text-align: center;"><b>OR</b></p> <ul style="list-style-type: none"> <li>• The AE is considered likely to be related to an etiology other than the use of the IP; that is, there are no facts, evidence, or arguments to suggest a causal relationship to the IP.</li> </ul>  |
| Related      | <ul style="list-style-type: none"> <li>• The administration of the IP and the occurrence of the AE are reasonably related in time</li> </ul> <p style="text-align: center;"><b><u>AND</u></b></p> <ul style="list-style-type: none"> <li>• The AE could possibly be explained by factors or causes other than exposure to the IP</li> </ul> <p style="text-align: center;"><b><u>OR</u></b></p> <ul style="list-style-type: none"> <li>• The administration of IP and the occurrence of the AE are reasonably related in time</li> </ul> <p style="text-align: center;"><b><u>AND</u></b></p> <ul style="list-style-type: none"> <li>• The AE is more likely explained by exposure to the IP than by other factors or causes.</li> </ul> |

Factors suggestive of a causal relationship could include (but are not limited to):

- Plausible temporal relationship
- Absence of alternative explanations
- Rarity of event in a given patient or disease state
- Absence of event prior to study drug exposure
- Consistency with study product pharmacology
- Known relationship to underlying mechanism of study drug action
- Similarity to adverse reactions seen with related drug products
- Abatement of AE with discontinuation of study drug, and/or recurrence of AE with reintroduction of study drug

The Investigator's assessment of causality for individual AE reports is part of the study documentation process. Regardless of the Investigator's assessment of causality for individual AE reports, the Sponsor will promptly evaluate all reported SAEs against



cumulative product experience to identify and expeditiously communicate possible new safety findings to Investigators and applicable regulatory authorities.

## **10.4 Procedures for Recording Adverse Events**

### **10.4.1 Recording Adverse Events on a eCRF**

Investigators should use precise medical terminology when recording AEs or SAEs on the AE eCRF. Avoid colloquialisms and abbreviations.

Record only one diagnosis, sign, or symptom per event field on the AE eCRF (eg, nausea and vomiting should not be recorded in the same entry, but as 2 separate entries).

In order to classify AEs and diseases, preferred terms will be assigned by the Sponsor to the original terms entered on the AE eCRF, using MedDRA (Medical Dictionary for Regulatory Activities) terminology.

#### **10.4.1.1 Diagnosis versus Signs and Symptoms**

The Investigator will attempt to establish a diagnosis of the event based on signs, symptoms, and/or other clinical information. Whenever possible, the diagnosis (not the individual signs/symptoms) will be documented as the AE/SAE. Using accepted medical terminology, enter the diagnosis (if known). If not known, enter sign(s) and/or symptom(s). If a diagnosis subsequently becomes available, then this diagnosis should be entered on the AE (or SAE, as appropriate) eCRF, replacing the original entries where appropriate.

#### **10.4.1.2 Adverse Events Occurring Secondary to Other Events**

In general, AEs occurring secondary to other events (eg, cascade events) should be identified by their primary cause. For example, if severe diarrhea is known to have resulted in dehydration, it is sufficient to record only diarrhea as an AE or SAE on the AE eCRF. However, medically important events that may be linked and/or separated in time should be recorded as independent events on the AE eCRF. For example, if severe hemorrhage leads to renal failure, both events should be recorded separately on the AE eCRF.

#### **10.4.1.3 Persistent or Recurrent Adverse Events**

A persistent AE (duration of adverse event > 7 days) is one that extends continuously, without resolution, between subject evaluation time points. Events that change in severity necessitate the recording of an additional AE. AEs that do not have a change in severity should be recorded only once on the eCRF.

A recurrent AE is one that occurs and resolves between subject evaluation time points, but then subsequently recurs. All recurrences of the AE should be recorded on the AE eCRF.



For example, if a subject has an adverse event of ALT increased that subsequently resolves, but the subject's ALT increases again, that should be reported as two adverse events – the initial ALT increase, and the second ALT increase.

#### 10.4.1.4 Abnormal Laboratory Values

Laboratory test results will be recorded on the laboratory results pages of the eCRF, or appear on electronically produced laboratory reports submitted directly from the central laboratory, if applicable.

Any laboratory result abnormality fulfilling the criteria for a SAE or EOSI should be reported as such, and recorded in the AE eCRF.

Any laboratory result abnormality of CTCAE Grade 4 or 5 should be recorded as an SAE in the AE eCRF.

A clinical laboratory abnormality is considered clinically significant and should be documented as an AE if not refuted by a repeat test to confirm the abnormality and **any** one or more of the following conditions is met:

- Accompanied by clinical symptoms
- Requiring a change in concomitant therapy (eg, addition of, interruption of, discontinuation of, or any other change in a concomitant medication, therapy or treatment).
- The abnormality suggests a disease and/or organ toxicity
- The abnormality is of a degree that requires active management (eg, change of dose, discontinuation of study drug, more frequent follow-up assessments, further diagnostic investigation, etc.)

**This applies to** any protocol and non-protocol specified safety and efficacy laboratory result from tests performed after the first dose of study medication that falls outside the laboratory reference range and meets the clinical significance criteria.

**This does not apply to** any abnormal laboratory result that falls outside the laboratory reference range but that does not meet the clinical significance criteria (these will be analyzed and reported as laboratory abnormalities), those that are considered AEs of the type explicitly exempted by the protocol, or those which are a result of an AE that has already been reported.

For purposes of this study, laboratory tests showing a decreased level of FVIII activity should not be reported as adverse events unless there is an impact to clinical outcomes (eg, increased rate of bleeding, worsening of joint disease).



#### **10.4.1.5 Pre-existing Conditions**

A pre-existing condition is one that is present prior to administration of BMN 270. Such conditions should be recorded as medical history on the appropriate eCRF.

A pre-existing condition should be recorded as an AE or SAE during the study **only** if the frequency, intensity, or character of the condition worsens during the study period. It is important to convey the concept that a pre-existing condition has changed by including applicable language in the verbatim description of the event (eg, *more frequent* headaches).

#### **10.4.1.6 General Physical Examination Findings**

At screening, any clinically significant abnormality should be recorded as a pre-existing condition (refer to Section 10.4.1.5). During the study, any new clinically significant findings and/or abnormalities discovered on physical examination that meet the definition of an AE (or an SAE) must be recorded and documented as an AE or SAE on the AE eCRF.

#### **10.4.1.7 Hospitalization, Prolonged Hospitalization, or Surgery**

Any AE that results in hospitalization or prolonged hospitalization should be documented and reported as an SAE unless specifically instructed otherwise in this protocol (refer to Section 10.2).

There are some hospitalization scenarios that do not require reporting as an SAE when there is no occurrence of an AE. These scenarios include planned hospitalizations or prolonged hospitalizations to:

- Perform a protocol-mandated efficacy measurement
- Undergo a diagnostic or elective surgical procedure for a pre-existing medical condition that has not worsened
- Insert an in-dwelling IV catheter (such as a Port-a-Cath or other brand, if applicable) for administration of study drug or FVIII replacement therapy
- Receive scheduled therapy (study drug or otherwise) for the study indication

#### **10.4.1.8 Deaths**

All deaths that occur during the AE reporting period (refer to Section 10.3.1), regardless of attribution, will be recorded on the AE eCRF and expeditiously reported to the Sponsor as an SAE.

When recording a death, the event or condition that caused or contributed to the fatal outcome should be recorded as the single medical concept on the eCRF. If the cause of death





is unknown and cannot be ascertained at the time of reporting, record “Unexplained Death” or “Death of Unknown Cause” on the AE eCRF.

#### **10.4.1.9 Pregnancy**

Although not an AE per se, pregnancy in the partner of a subject taking trial medication should be reported expeditiously to the Sponsor to facilitate outcome monitoring by the Sponsor. Pregnancy in partner should be reported during the period up to 5 years after viral infusion.

Pregnancy in a partner should be reported within 24 hours of the site becoming aware of the pregnancy by entering the information on the Pregnancy eCRF and submitting to BPV within 24 hours of the site becoming aware of the event. The Investigator must make every effort to follow the subject’s partner (with that partner’s consent) through resolution of the pregnancy (delivery or termination) and to report the resolution on the Pregnancy Follow-up eCRF. In the event of pregnancy in the partner of a study subject, the Investigator should make every reasonable attempt to obtain the woman’s consent for release of protected health information.

Abortion, whether therapeutic or spontaneous, should always be classified as an SAE (as the Sponsor considers these to be medically significant), recorded on the AE eCRF, and expeditiously reported to the Sponsor as an SAE.

### **10.5 Reporting Requirements**

#### **10.5.1 Expedited Reporting Requirements**

All SAEs and EOSI that occur during the course of the AE Reporting Period (refer to Section 10.3.1), whether or not considered related to study drug, must be reported by entering the information in the AE eCRF and submitting to BPV within 24 hours of the site becoming aware of the event. Investigators should not wait to collect information that fully documents the event before notifying BPV of an SAE. BioMarin may be required to report certain SAEs to regulatory authorities within 7 calendar days of being notified about the event; therefore, it is important that Investigators submit any information requested by BioMarin as soon as it becomes available. IND safety reports will be submitted within 7 calendar days for fatal or life-threatening unexpected suspected adverse reactions (SUSARs) and within 15 calendar days for other non-life-threatening SUSARs

The Sponsor is responsible for identifying, preparing and reporting all SUSARs to the relevant competent authorities, ethics committees and Investigators in accordance with the requirements identified in the Clinical Trials Regulations.





If the EDC is unavailable, all SAEs should be reported to BPV by completing the SAE Report Form and faxing or emailing the completed form to BPV within 24 hours of the site becoming aware of the event. Once the EDC is available, the information should be entered in the AE eCRF.

### **10.5.2 Institutional Review Board or Independent Ethics Committee Reporting Requirements**

Reporting of SAEs to the Independent Ethics Committee (IEC) or Institutional Review Board (IRB) will be done in compliance with the standard operating procedures and policies of the IEC/IRB and with applicable regulatory requirements. Adequate documentation must be obtained by BioMarin showing that the IEC/IRB was properly and promptly notified as required.

### **10.6 Follow-up of Subjects after Adverse Events**

After the initial AE/SAE/EOSI report, the Investigator is required to proactively follow each subject at subsequent visits/contacts. All AEs/SAEs/EOSI will be followed until resolution, stabilization, the event is otherwise explained, or the subject is lost to follow-up. Resolution of AEs/SAEs/EOSI (with dates) should be documented on the AE eCRF and submitted to BioMarin Pharmacovigilance and in the subject's medical record to facilitate source data verification.

For some SAEs and EOSI, the Sponsor may follow up by telephone, fax, electronic mail, and/or a monitoring visit to obtain additional case details (eg, hospital discharge summary, consultant report, or autopsy report) deemed necessary to appropriately evaluate the SAE or EOSI report.

### **10.7 Post-Study Adverse Events**

At the last scheduled visit, the Investigator should instruct each subject to report, to the Investigator and/or to BPV directly, any subsequent SAEs that the subject's personal physician(s) believes might be related to prior study drug.

The Investigator should notify the study Sponsor of any death or SAE occurring at any time after a subject has discontinued or terminated study participation, if the Investigator believes that the death or SAE may have been related to prior study drug. The Sponsor should also be notified if the Investigator should become aware of the development of cancer or of a congenital anomaly in a subsequently conceived offspring of a subject that participated in this study.



## 10.8 Urgent Safety Measures

The regulations governing clinical trials state that the Sponsor and Investigator are required to take appropriate urgent safety measures to protect subjects against any immediate hazards that may affect the safety of subjects, and that the appropriate regulatory bodies should be notified according to their respective regulations. According to the European Union (EU) Clinical Trial Directive 2001/20/EC, "...in the light of the circumstances, notably the occurrence of any new event relating to the conduct of the trial or the development of the investigational medicinal product where that new event is likely to affect the safety of the patients, the Sponsor and the Investigator shall take appropriate urgent safety measures to protect the patients against any immediate hazard. The Sponsor shall forthwith inform the competent authorities of those new events and the measures taken and shall ensure that the IRB/IEC/REB is notified at the same time."

The reporting period for these events which may require the implementation of urgent safety measures is the period from the time of signing of the ICF through the completion of the last study visit or at the Early Termination Visit (ETV). Investigators are required to report any events which may require the implementation of urgent safety measures to BioMarin within 24 hours.

Examples of situations that may require urgent safety measures include discovery of the following:

- Lack of study scientific value, or detrimental study conduct or management
- Discovery that the quality or safety of the IP does not meet established safety requirements



---

### 10.9 BioMarin Pharmacovigilance Contact Information

Contact information for BioMarin Pharmacovigilance is as follows:

BioMarin Pharmaceutical Inc.

Address 105 Digital Drive  
Novato, CA 94949  
Phone: +1 (415) 506-6179  
Fax: +1 (415) 532-3144  
E-mail: [drugsafety@bmrn.com](mailto:drugsafety@bmrn.com)

The Investigator is encouraged to discuss with the Medical Monitor any AEs for which the issue of seriousness is unclear or questioned. Contact information for the Medical Monitor is as follows:

Name: **PI** [redacted] MD, MPhil  
Address: 105 Digital Drive  
Novato, CA 94949 USA  
Phone: **PI** [redacted]  
E-mail: **PI** [redacted]



---

## 11 APPROPRIATENESS OF MEASUREMENTS

The measures of efficacy to be used in this study are standard, ie, widely used and generally recognized as reliable, accurate, and relevant (able to discriminate between effective and ineffective agents). The measures of safety used in this study are routine clinical and laboratory procedures.

The chromogenic substrate FVIII assay and the one-stage clotting FVIII assay are both validated and utilize CE marked reagents. The exploratory FVIII activity assay will be used for exploratory purposes only.



## 12 STUDY PROCEDURES

### 12.1 Prestudy

An ICF must be signed and dated by the patient, the Investigator or designee and witness (if required) before any study-related procedures are performed.

### 12.2 Screening Visit

Screening assessments should be performed within 28 days of BMN 270 infusion (and must be performed within 42 days prior to BMN 270 infusion), while baseline assessments will take place within 7 days prior to BMN 270 infusion (Day 1). Should the screening visit occur within 30 days of the drug infusion, physical examination, vital signs, blood chemistry, LTs, hematology, urine tests, and coagulation tests do not need to be repeated at Baseline.

The following procedures will be performed during the Screening Period:

- Demographics (age, sex, race, ethnicity)
- Full medical history, including hemophilia A history, Hepatitis B, Hepatitis C, and HIV. Subjects with a history of hepatitis B or hepatitis C will be asked for information about the treatments received. Any prior pharmacokinetics information obtained while the subject was receiving prophylactic or on-demand FVIII therapy prior to the study should also be collected.
- Complete Physical Examination
- Height and weight
- Vital Signs (systolic and diastolic blood pressure, heart rate, respiration rate, and temperature)
- Assessment of Adverse Events and Concomitant Medications
- Documentation of bleeding episodes and FVIII usage (by either subject or clinical information) for the previous 12 months
  - Further information on details to be included in documentation of previous bleeding episodes and FVIII usage, refer to the On Site File Binder.
- Distribution of subject diaries and training in diary completion
- Electrocardiogram
- Liver Ultrasound
- Samples for hFVIII Assays
  - Baseline FVIII activity – chromogenic substrate FVIII assay
  - Baseline FVIII activity level – one-stage clotting FVIII assay



- hFVIII coagulation activity exploratory assay (collected but not tested prior to enrollment)
- hFVIII inhibitors (Bethesda assay with Nijmegen modification)
- hFVIII total antibody assay (collected but not tested prior to enrollment)
- hFVIII protein assay (collected but not tested prior to enrollment)
- Blood sample for AAV5 total antibody (TAb) assay
- Screen for Hepatitis B, Hepatitis C, and HIV if required (subjects with documented negative results 30 days prior to informed consent being obtained do not need to be retested)
  - Hepatitis B screening should include HBsAg, HBsAb, and HBcAb.
- Blood chemistry, hematology, and coagulation tests (refer to [Table 9.7.8.2.1](#))
- Urine Tests (refer to [Table 9.7.8.2.1](#))
- Liver Tests (refer to [Table 9.7.8.3.1](#))
- Blood samples for Biomarker testing (including HLA genotyping and FVIII genotyping status)

### 12.2.1 “Smart Rescreening” Visit

Subjects who undergo smart rescreening must complete the rescreening assessments and receive the infusion within 90 days of signing the original consent. Subjects who do not complete dosing within 90 days will be required to re-consent and undergo all screening procedures. Subjects may not undergo smart rescreening more than once.

If a patient has to be screened again because the original assessments have fallen out of the 28 + 14 day period allowed for Screening (refer to Section [12.2](#)), then only the following assessments need to be performed (rather than the full list indicated in Section [12.2](#)) for the patient to be successfully re-screened for the study:

- Vital signs
- Assessment of Adverse Events and Concomitant Medications
- Documentation of bleeding episodes and FVIII usage (by either subject or clinical information)
- hFVIII Assays (only the hFVIII inhibitor level (Bethesda assay with Nijmegen modification))
- AAV5 Total Antibody assay
- Blood chemistry, hematology, and coagulation tests (refer to [Table 9.7.8.2.1](#))



- Urine Tests (refer to [Table 9.7.8.2.1](#))
- Liver Tests (refer to [Table 9.7.8.3.1](#))

### 12.3 Baseline Visit

Baseline values will be recorded from 1 to 7 days prior to the treatment visit. The following procedures will be performed during the Baseline Period:

- Brief physical examination
- Vital signs
- Assessment of Adverse Events and Concomitant Medications
- Documentation of bleeding episodes and FVIII usage (by either subject or clinical information)
- Blood sample for AAV5 TI assay
- Blood sample for AAV5 TAb assay
- Blood chemistry, hematology, and coagulation tests (refer to [Table 9.7.8.2.1](#))
  - ABO blood typing assessment should be performed as part of the hematology assessment (at Baseline, or at another regularly scheduled visit prior to the end of the subject's participation in the study).
- Urine Tests (refer to [Table 9.7.8.2.1](#))
- Liver Tests (refer to [Table 9.7.8.3.1](#))
- Samples for hFVIII Assays
  - Baseline FVIII activity – chromogenic substrate FVIII assay
  - Baseline FVIII activity level – one-stage clotting FVIII assay
  - hFVIII coagulation activity exploratory assay
  - hFVIII inhibitors (Bethesda assay with Nijmegen modification)
  - hFVIII total antibody assay
  - hFVIII protein assay
- PBMC collection for CTL baseline
- Von Willebrand Factor Antigen (VWF:Ag)
- TGA Assay
- PCR of vector DNA in blood, saliva, urine, semen, and stools
- Exploratory biomarker assessments



- Haemo-QoL-A assessment
- EQ-5D-5L
- Hemophilia Activities List (HAL)
- Work Productivity and Activity Impairment plus Classroom Impairment Questions: Hemophilia Specific (WPAI+CIQ:HS) questionnaire
- Patient Reported Outcomes, Burdens, and Experiences (PROBE) questionnaire

#### **12.4 Treatment Visit/BMN 270 Infusion Visit (Day 1)**

There will be one treatment visit for each subject. Subjects will remain in the clinic for at least 8 hours for the BMN 270 Infusion Visit. The following procedures will be performed during the BMN 270 Infusion Visit:

- Brief physical examination
- Assessment of Adverse Events and Concomitant Medications
- AAV5 TAb Assay (sample collected pre-infusion for analysis)
- Fasting lipid panel (blood triglycerides, total cholesterol, HDL cholesterol, and LDL cholesterol) (sample collected pre-infusion)
  - Subjects will fast for at least 8 hours prior to pre-infusion laboratory sampling on the day of the infusion visit.
- Exploratory biomarker assessments
- BMN 270 Infusion
- Vital Signs
  - Vital signs will be recorded prior to BMN 270 infusion and then every 15 minutes ( $\pm$  5 minutes) during BMN 270 infusion. Following infusion, vital signs will be monitored every 1 hour ( $\pm$  5 minutes) for at least 8 hours during the subject's stay in the clinic.
- PCR of vector DNA in blood, saliva, urine, semen, and stools
  - Collection of samples for PCR testing should occur between 2 and 24 hours after the BMN 270 infusion has been completed

In case of hypersensitivity or adverse drug reaction, safety assessment, including physical examination and vital signs, will be done and additional blood samples will be collected within 1 hour of the hypersensitivity reaction (eg, tryptase, C3, C3a, C4, C5, C5a, and cytokine bead array, as well as possible additional exploratory testing) and samples for IgE and cytokine bead array (and possible additional exploratory testing) between 8-24 hours after the reaction, if possible. In addition, a blood sample should be taken 1 week after the





hypersensitivity reaction for assessment of the cytokine bead array. In-patient observation can be extended and additional blood samples can be collected if deemed necessary at the discretion of the Investigator and Medical Monitor.

## **12.5 BMN 270 Infusion Follow-Up Visits – Weeks 1-26**

After BMN 270 has been infused, subjects will return to the study site every week ( $\pm$  48 hours) during Weeks 1-26. For subjects who have enrolled in 270-301 following participation in 270-902, optional MN services or shortened lab draw-only site visits may be conducted for the visits at Week 5, Week 7, Week 9, Week 11, Week 13, Week 15, Week 17, Week 19, Week 21, Week 23, and Week 25.

At the Weeks 1-26 visits, the following procedures will be completed:

### **12.5.1 Once per week (Weeks 1 through 26)**

The following procedures will be performed at one visit per week from Weeks 1 through 26:

- Brief physical examination (complete physical examination at Week 26)
  - For visits where a MN service is being used or a lab draw-only site visit is conducted, physical examination will not be performed.
- Assessment of Adverse Events and Concomitant Medications (including review of subject diary for bleeding and FVIII use)
  - For visits where a MN service is being used, the service will contact the subject via e-mail or phone call to collect information regarding adverse events, changes to concomitant medications, bleeding episodes, and FVIII use.
- Vital Signs
  - For visits where a MN service is being used or a lab draw-only site visit is conducted, vital signs will not be performed.
- Liver Tests (refer to [Table 9.7.8.3.1](#))
  - LTs may be monitored more or less frequently (and in particular when ALT values are  $\geq 1.5x$  ULN or  $> ULN$  &  $> 2x$  baseline value) based on discussion between the Medical Monitor and the Investigator and review of subject data, but LTs will be monitored at least twice weekly during periods when a subject's ALT is  $\geq 3x$  ULN.
- Samples for FVIII Assays
  - FVIII activity level (chromogenic substrate FVIII assay)
  - FVIII activity level (one-stage clotting FVIII assay)



- FVIII coagulation activity exploratory assay
- Bethesda assay (with Nijmegen modification) for hFVIII inhibitor level
- FVIII protein assay

#### **12.5.2 Week 1 – Day 4**

On Day 4 of Week 1, the following procedures will be performed:

- PCR of vector DNA in blood, saliva, urine, semen, and stools
- Liver Tests (refer to [Table 9.7.8.3.1](#))

#### **12.5.3 Week 1 – Day 8**

On Day 8, the following procedures will be performed, in addition to the weekly assessments required in [Section 12.5.1](#):

- PCR of vector DNA in blood, saliva, urine, semen, and stools

#### **12.5.4 Every 2 Weeks (Week 2, 4, 6, 8, 10, 12, 14, 16, 18, 20, 22, 24, and 26)**

At Weeks 2, 4, 6, 8, 10, 12, 14, 16, 18, 20, 22, 24, and 26 the following procedure will be performed:

- PBMC collection

#### **12.5.5 Weeks 2, 4, 10, 16, 22, and 26**

At Weeks 2, 4, 10, 16, 22, and 26 the following procedure will be performed:

- Blood chemistry, hematology, and coagulation tests (refer to [Table 9.7.8.2.1](#))

#### **12.5.6 Weeks 2, 3, 4, 6, 8, 12, 16, 20, 24, and 26**

At Weeks 2, 3, 4, 6, 8, 12, 16, 20, 24, and 26, the following procedure will be performed:

- PCR of vector DNA in blood, saliva, urine, semen, and stools
  - Collection to occur until at least 3 consecutive negative results are obtained. Semen samples should continue to be collected and tested through Week 12, even if 3 consecutive negative results in that compartment have been recorded prior to that time point.

#### **12.5.7 Weeks 4, 12, and 26**

At Weeks 4, 12, and 26, the following procedure will be performed:

- Haemo-QoL-A assessment
- EQ-5D-5L



- HAL
- WPAI+CIQ:HS
- PROBE

#### **12.5.8 Every 4 Weeks (Weeks 4, 8, 12, 16, 20, and 24) Plus Week 26**

At Weeks 4, 8, 12, 16, 20, 24, and 26, the following procedures will be performed:

- Weight (not performed at Week 26)
- FVIII antibody titer

#### **12.5.9 Every 8 Weeks (Weeks 8, 16, and 24)**

At Weeks 8, 16, and 24, the following procedures will be performed:

- AAV5 TAb assay
- AAV5 TI assay

#### **12.5.10 Weeks 6, 12, 16, 20, 24, and 26**

At Weeks 6, 12, 16, 20, 24, and 26, the following procedures will be performed:

- Exploratory biomarker assessments

#### **12.5.11 Weeks 12 and 26**

At Weeks 12 and 26, the following procedures will be performed:

- Urine Tests (refer to [Table 9.7.8.2.1](#))
- VWF:Ag

#### **12.5.12 Week 16**

At Week 16, the following procedure will be performed:

- Test for Hepatitis B and Hepatitis C reactivation (only in subjects with evidence of prior exposure to hepatitis B and/or hepatitis C)
  - Subjects who receive therapeutic oral corticosteroids prior to Week 16 do not need to complete the Week 16 reactivation assessment; instead, they will be tested for hepatitis B and hepatitis C reactivation at the time points listed in [Table 9.1.6](#).

#### **12.5.13 Week 20, 24, and 26**

At Week 20, 24, and 26, the following procedure will be performed:

- TGA Assay



## 12.6 Post-Infusion Follow-Up – Weeks 27-52

During Weeks 27-36, subjects will return to the study site weekly ( $\pm$  48 hours). During Weeks 37-52, subjects will return to the study site every 2 weeks (Week 38, 40, 42, 44, 46, 48, 50, and 52) ( $\pm$  1 week). For subjects who have enrolled in 270-301 following participation in 270-902, optional MN services or shortened lab draw-only site visits may be conducted at Week 27, Week 29, Week 30, Week 31, Week 33, Week 34, Week 35, Week 38, Week 42, Week 46, and Week 50.

At these visits, the following procedures will be completed:

### 12.6.1 Every Visit

At every visit (Weeks 27-36, 38, 40, 42, 44, 46, 48, 50, and 52), the following procedures will be performed:

- Physical examination
  - Brief physical examination should be performed at all weeks except Week 26, when a complete physical examination should be performed
  - For visits where a MN service is being used or a lab draw-only site visit is conducted, physical examination will not be performed.
- Assessment of Adverse Events and Concomitant Medications (including review of subject diary for bleeding and FVIII use)
  - For visits where a MN service is being used, the service will contact the subject via e-mail or phone call to collect information regarding adverse events, changes to concomitant medications, bleeding episodes, and FVIII use.
- Vital Signs
  - For visits where a MN service is being used or a lab draw-only site visit is conducted, vital signs will not be performed.
- Liver Tests (refer to [Table 9.7.8.3.1](#))
  - LTs may be monitored more or less frequently (and in particular when ALT values are  $\geq 1.5x$  ULN or  $> ULN$  &  $> 2x$  baseline value) based on discussion between the Medical Monitor and the Investigator and review of subject data, but LTs will be monitored at least twice weekly during periods when a subject's ALT is  $\geq 3x$  ULN.
- FVIII Assays
  - FVIII activity level (chromogenic substrate FVIII assay)
  - FVIII activity level (one-stage clotting FVIII assay)



- FVIII coagulation activity exploratory assay
- Bethesda assay (with Nijmegen modification) for FVIII inhibitor level
- FVIII protein assay

#### **12.6.2 Weeks 28, 30, 32, 36, 44, and 52**

At Weeks 28, 30, 32, 36, 44, and 52, the following procedure will be performed:

- PBMC collection

#### **12.6.3 Every 4 Weeks (Weeks 28, 32, 36, 40, 44, 48, 52)**

At Weeks 28, 32, 36, 40, 44, 48, and 52, the following procedure will be performed:

- Weight

#### **12.6.4 Weeks 32, 36, 44, and 52**

At Weeks 32, 36, 44, and 52, the following procedures will be performed:

- Blood chemistry, hematology, and coagulation tests (refer to [Table 9.7.8.2.1](#))
- FVIII antibody titer

#### **12.6.5 Weeks 32, 36, 40, 44, 48, and 52**

At Weeks 32, 36, 40, 44, 48, and 52, the following procedures will be performed:

- Exploratory biomarker assessments
- TGA Assay
- PCR of vector DNA in blood, saliva, urine, semen, and stools
  - Sample testing to occur until at least 3 consecutive negative sample results have been obtained. Subjects who have not had 3 consecutive negative semen samples by Week 52 should continue to have PCR testing of semen every 4 weeks until 3 consecutive negative samples are documented (or upon consultation between the Investigator and Medical Monitor).

#### **12.6.6 Week 32, 36, and 52**

At Week 32, 36, and 52, the following procedure will be performed:

- AAV5 TAb Assay
- AAV5 TI Assay

#### **12.6.7 Week 36 and 52**

At Weeks 36 and 52, the following procedures will be performed:



- Urine Tests (refer to [Table 9.7.8.2.1](#))
- VWF:Ag

### **12.6.8 Week 52**

At Week 52, the following procedures will be performed:

- Haemo-QoL-A assessment
- EQ-5D-5L
- HAL
- WPAI+CIQ:HS
- PROBE

### **12.7 Post-Infusion Follow-Up – Years 2-5**

During Years 2-5, at applicable sites, certain study assessments may be performed by a mobile nursing (MN) professional at the patient's home or another suitable location, such as their school or office, to improve access and convenience for patients participating in the study. The Sponsor may select a healthcare company that will be responsible for providing MN services for participating sites (the MN vendor). The MN vendor is responsible for ensuring that all MN professionals are licensed, qualified, and in good standing, as per applicable regulations, and that appropriate background checks have been performed. If the investigator at a participating site determines that MN services are appropriate for a patient and the patient gives written informed consent to participate in MN visits, the MN network will communicate with the patient and the patient's site. MN visits will be allowed for the Q4W (during Year 2) and Q6W (during Years 3-5) visits; the Q12W visits and End of Year visits during Years 2-5 will not be performed by an MN professional but will be done at the study site.

Subjects who do not respond to BMN 270 treatment (ie, treatment failure, manifesting as either failure to achieve FVIII activity  $\geq 5$  IU/dL by Week 52 or inability to maintain independence from prophylactic FVIII replacement therapy due to joint bleeding episodes, in the judgment of the Investigator) may, at the Investigator's discretion and after discussion with the Medical Monitor or Sponsor-designated Data Monitor, follow an abbreviated visit schedule after Week 52 of the study by attending only the Q12W and End of Year visits during Years 2-5.

Subjects who meet the definition of treatment failure and wish to follow an abbreviated schedule but who have not cleared vector shedding from all fluids must still provide samples for assessment every 4 weeks (during Year 2) or every 6 weeks (during Years 3-5) until



vector shedding has cleared. Such subjects may provide samples on the designated study visit dates either at the sites or through use of a MN professional.

During Years 2-5 of Post-Infusion Follow-up, the following procedures will be completed:

### **12.7.1 Year 2 – Every 4 Weeks (not required for treatment failure)**

During Year 2, every 4 weeks ( $\pm 2$  weeks), the following procedures will be performed:

- Assessment of Adverse Events and Concomitant Medications (including review of subject diary for bleeding and FVIII use)
- Liver Tests (refer to [Table 9.7.8.3.1](#))
  - LTs may be monitored more or less frequently (and in particular when ALT values are  $\geq 1.5x$  ULN or  $> ULN$  &  $> 2x$  baseline value) based on discussion between the Medical Monitor and the Investigator and review of subject data, but LTs will be monitored at least twice weekly during periods when a subject's ALT is  $\geq 3x$  ULN.
- FVIII Assays
  - FVIII activity level (chromogenic substrate FVIII assay)
  - FVIII activity level (one-stage clotting FVIII assay)
  - FVIII coagulation activity exploratory assay
  - Bethesda assay (with Nijmegen modification) for FVIII inhibitor level
  - FVIII protein assay
- PCR of vector DNA in blood, saliva, urine, semen, and stools (if required)
  - Sample testing during Year 2 is not required if at least 3 consecutive samples are negative during the Post-Infusion Follow-Up period in Weeks 1-52. Subjects who have not had 3 consecutive negative semen samples by Week 52 should continue to have PCR testing of semen every 4 weeks during Years 2 until 3 consecutive negative samples are documented (or upon consultation between the Investigator and Medical Monitor).
  - Subjects who meet the definition of treatment failure and wish to follow an abbreviated schedule but who have not cleared vector shedding from all fluids must still provide samples for assessment every 4 weeks during Year 2 until vector shedding has cleared. Such subjects may provide samples on the designated study visit dates either at the sites or through use of a MN professional.



### 12.7.2 Years 3-5 – Every 6 Weeks (not required for treatment failure)

During Years 3-5, every 6 weeks ( $\pm 2$  weeks), the following procedures will be performed:

- Assessment of Adverse Events and Concomitant Medications (including review of subject diary for bleeding and FVIII use)
- Liver Tests (refer to [Table 9.7.8.3.1](#))
  - LTs may be monitored more or less frequently (and in particular when ALT values are  $\geq 1.5x$  ULN or  $> ULN$  &  $> 2x$  baseline value) based on discussion between the Medical Monitor and the Investigator and review of subject data, but LTs will be monitored at least twice weekly during periods when a subject's ALT is  $\geq 3x$  ULN.
- FVIII Assays
  - FVIII activity level (chromogenic substrate FVIII assay)
  - FVIII activity level (one-stage clotting FVIII assay)
  - FVIII coagulation activity exploratory assay
  - Bethesda assay (with Nijmegen modification) for FVIII inhibitor level
    - If a subject tests positive in the Bethesda assay (with Nijmegen modification) during Years 3-5, a fresh sample should be collected within 4 weeks of the initial visit that had a positive result.
  - FVIII protein assay
- PCR of vector DNA in blood, saliva, urine, semen, and stools (if required)
  - Sample testing during Years 3-5 is not required if at least 3 consecutive samples are clear by the end of Year 2. Subjects who have not had 3 consecutive negative semen samples by the end of Year 2 should continue to have PCR testing of semen every 6 weeks during Years 3-5 until 3 consecutive negative samples are documented (or upon consultation between the Investigator and Medical Monitor).
  - Subjects who meet the definition of treatment failure and wish to follow an abbreviated schedule but who have not cleared vector shedding from all fluids must still provide samples for assessment every 6 weeks during Years 3-5 until vector shedding has cleared. Such subjects may provide samples on the designated study visit dates either at the sites or through use of a MN professional.





### 12.7.3 Years 2-5 – Every 12 Weeks and End of Year Visits (required for all subjects)

During Years 2-5, subjects will be asked to return to the study site for visits at the following study weeks ( $\pm 2$  weeks):

- Year 2 – Week 64, Week 76, Week 88, Week 104
- Year 3 – Week 116, Week 128, Week 140, Week 156
- Year 4 – Week 168, Week 180, Week 192, Week 208
- Year 5 – Week 220, Week 232, Week 244, Week 260

For each of these years, the last study visit listed (Week 104, Week 156, Week 208, and Week 260) will serve as an End of Year visit. The every 12 week and End of Year visits may not be performed remotely by MN services.

At the every 12 week and End of Year visits, the following procedures will be performed:

- Physical examination
  - Complete physical examination will be performed at the End of Year visits; brief physical examination may be performed at other visits.
- Weight (at Week 76, Week 128, Week 180, Week 232, and End of Year visits only)
- Assessment of Adverse Events and Concomitant Medications (including review of subject diary for bleeding and FVIII use)
- Liver Tests (refer to [Table 9.7.8.3.1](#))
  - LTs may be monitored more or less frequently (and in particular when ALT values are  $\geq 1.5x$  ULN or  $> ULN$  &  $> 2x$  baseline value) based on discussion between the Medical Monitor and the Investigator and review of subject data, but LTs will be monitored at least twice weekly during periods when a subject's ALT is  $\geq 3x$  ULN.
- FVIII Assays
  - FVIII activity level (chromogenic substrate FVIII assay)
  - FVIII activity level (one-stage clotting FVIII assay)
  - FVIII coagulation activity exploratory assay
  - Bethesda assay (with Nijmegen modification) for FVIII inhibitor level
    - If a subject tests positive in the Bethesda assay (with Nijmegen modification) during Years 3-5, a fresh sample should be collected within 4 weeks of the initial visit that had a positive result.
  - FVIII protein assay



- Blood chemistry, hematology, and coagulation tests (refer to [Table 9.7.8.2.1](#)) (at Week 76, Week 128, Week 180, Week 232, and End of Year visits only)
- Urine Tests (refer to [Table 9.7.8.2.1](#)) (at Week 76, Week 128, Week 180, Week 232, and End of Year visits only)
- Vital Signs
- AAV5 TAb Assay
- AAV5 TI Assay
- FVIII antibody titer
- Haemo-QoL-A assessment (at Week 76, Week 128, Week 180, Week 232, and End of Year visits only)
- EQ-5D-5L (at Week 76, Week 128, Week 180, Week 232, and End of Year visits only)
- HAL (at Week 76, Week 128, Week 180, Week 232, and End of Year visits only)
- WPAI+CIQ:HS (at Week 76, Week 128, Week 180, Week 232, and End of Year visits only)
- PROBE (at Week 76, Week 128, Week 180, Week 232, and End of Year visits only)
- Exploratory biomarker assessments
- PBMC collection
- VWF:Ag
- TGA Assay
- PCR of vector DNA in blood, saliva, urine, semen, and stools (if required)
  - Sample testing during Years 2-5 is not required if at least 3 consecutive samples are negative during the Post-Infusion Follow-Up period in Weeks 1-52. Subjects who have not had 3 consecutive negative semen samples by Week 52 should continue to have PCR testing of semen every 4 weeks (during Year 2) or every 6 weeks (during Years 3-5) until 3 consecutive negative samples are documented (or upon consultation between the Investigator and Medical Monitor).

## 12.8 Early Termination Visit

The Early Termination visit will occur on the date the subject withdraws from the study, even if the date does not correspond to a protocol-specific visit.



If a subject leaves the study prior to the Week 260 visit, the subject will be asked to return to the study site and complete an Early Termination visit. At the Early Termination visit, as many of the following assessments as possible should be done:

- Physical examination
- Weight
- Assessment of Adverse Events and Concomitant Medications (including review of subject diary for bleeding and FVIII use)
- Vital Signs
- Blood chemistry, hematology, and coagulation tests (refer to [Table 9.7.8.2.1](#))
- Urine Tests (refer to [Table 9.7.8.2.1](#))
- Liver Tests (refer to [Table 9.7.8.3.1](#))
- FVIII Assays
  - FVIII activity level (chromogenic substrate FVIII assay)
  - FVIII activity level (one-stage clotting FVIII assay)
  - FVIII coagulation activity exploratory assay
  - Bethesda assay (with Nijmegen modification) for FVIII inhibitor level
  - FVIII protein assay
- AAV5 TAb Assay
- AAV5 TI Assay
- FVIII antibody titer
- Exploratory biomarker assessments
- PBMC collection
- VWF:Ag
- TGA Assay
- PCR of vector DNA in blood, saliva, urine, semen, and stools
  - Sample testing at the ETV is not required if at least 3 consecutive samples were clear during the Post-Infusion Follow-Up period.
- Haemo-QoL-A assessment
- EQ-5D-5L
- HAL



- WPAI+CIQ:HS
- PROBE

### **12.9 End of Study**

The study will end after the last subject yet to complete the last Long-Term Follow-Up visit (Week 260) does so, has transferred to another BMN 270 study, is withdrawn from the study, or discontinues from the study. BioMarin reserves the right to discontinue the study any time for clinical or administrative reasons and to discontinue participation of an individual Investigator or site for clinical or administrative reasons, including, but not limited to, poor enrollment or noncompliance with procedures of the protocol or GCP. In addition, the study may be terminated if, in the opinion of BioMarin, the safety of the study subjects may be compromised.



### **13 DATA QUALITY ASSURANCE**

BioMarin personnel or designees will visit the study site prior to initiation of the study to review with the site personnel information about the IP, protocol and other regulatory document requirements, source document requirements, eCRFs, monitoring requirements, and procedures for reporting AEs, including SAEs.

At visits during and after the study, a CRA will monitor the site for compliance with regulatory documentation, with a focus on accurate and complete recording of data on eCRFs from source documents, adherence to protocol, randomization (if applicable), SAE reporting and drug accountability records.

Data quality control and analysis will be performed by BioMarin or a designee, based on a predefined analysis plan.



---

## 14 STATISTICAL METHODS AND DETERMINATION OF SAMPLE SIZE

### 14.1 Statistical and Analytical Plans

The statistical analysis plan (SAP) will provide additional details on the planned statistical analysis. Unless otherwise stated, all analyses will be performed using SAS.

#### 14.1.1 Interim Analyses

An interim analysis is planned after approximately 20 treated HIV-negative subjects have completed the Week 26 visit (or have discontinued study participation prior to Week 26). Data will be reviewed by the DMC, based on the SAP, and a formal recommendation will be made whether to continue the study as designed.

The primary efficacy endpoint for the interim analysis involves hFVIII activity, as measured by chromogenic substrate assay, achieved post-BMN 270 infusion.

The fallback procedure ([Wiens, 2005](#)) will be used to adjust for multiplicity of the interim analysis at Week 26 and the final analysis at Week 52 (regardless of the interim analysis results, the study is planned to continue upon the DMC's recommendation, and the final analysis will be performed at Week 52). At the final analysis at Week 52, the secondary efficacy endpoints will be tested hierarchically; the level of significance will be determined by the fallback procedure.

The secondary and tertiary endpoints will be summarized descriptively at the interim (Week 26) analysis.

The details of the interim analysis, including the control of Type I error rate, will be specified in the SAP.

#### 14.1.2 Procedures for Accounting for Missing, Unused and Spurious Data

Because the completeness of the data affects the integrity and accuracy of the final study analysis, every effort should be made to ensure complete, accurate, and timely data collection and, therefore, avoid missing data.

Missing data imputation and sensitivity analyses to assess the impact of missing data on the primary and secondary efficacy endpoints analyses are described in the following sections. Additional details regarding the handling of missing data will be provided in the SAP.

### 14.2 Primary Efficacy Endpoint

For the primary efficacy endpoint at Week 52 (ie, the change in the hFVIII activity during Weeks 49-52 post-BMN 270 infusion from baseline, as measured by chromogenic substrate



assay), a one-sample t-test will be used to test the null hypothesis that the change is 0 or less against the alternative hypothesis that the change is greater than 0. Descriptive summaries of the proportions of subjects whose FVIII activity during Weeks 49-52 is greater than or equal to select thresholds, such as 15, 25 and 30 IU/dL, and the confidence intervals of the proportions will also be provided.

For a subject with a missing value of the primary endpoint, the median value in the subject's last 4-week window containing a valid observation will be used. Additional analyses will be conducted to examine the sensitivity of the results to the handling of missing data, including analysis using observed cases, and a mixed model for repeated measures (MMRM) approach. Further detail will be provided in the SAP.

The analyses for the primary endpoint will be performed using the analysis populations as defined in Section 14.8.

### 14.3 Secondary Efficacy Endpoints

The primary analyses for the secondary endpoints will be performed on the 110 subjects in the mITT population who will be followed up for approximately 6 months in the non-interventional study 270-902 prior to their enrollment in 270-301. The baseline values will be derived from the prospectively collected data in 270-902.

For the first secondary efficacy endpoint at Week 52 (ie, the change in the annualized utilization (IU/kg) of exogenous FVIII replacement therapy during Weeks 5-52 post-BMN 270 infusion from baseline), a one-sample t-test will be performed to test the null hypothesis that the change is 0 or greater against the alternative hypothesis that the change is less than 0. The missing value of the change will be imputed as 0.

For the second secondary efficacy endpoint at Week 52 (ie, the change in ABR, annualized bleeding rate, during Weeks 5-52 post-BMN 270 infusion from baseline), a one-sample t-test will be performed to test for non-inferiority of BMN 270 against FVIII prophylaxis (ie, the baseline ABR calculated using subjects' data collected as part of 270-902) using a non-inferiority margin of 3.5, ie, to test the null hypothesis that the change is 3.5 or greater against the alternative hypothesis that the change is less than 3.5. If non-inferiority is demonstrated, the test for superiority of BMN 270 against FVIII prophylaxis will be performed. The missing value of the change will be imputed using the median value of the changes of all observed cases.

A sensitivity analysis is planned to analyze ABR using a generalized linear mixed model assuming negative binomial as the underlying distribution. The model will include period (pre- to post-BMN 270 infusion) as the only factor. The actual number of bleeding episodes



will be used as the independent variable with the time period adjustment (animalization) being implemented as the offset.

To assess the impact of missing data, analyses using observed case are planned as sensitivity analyses for the secondary endpoints. Multiple imputation methods may also be performed.

The primary and secondary efficacy hypotheses will be tested hierarchically according to the order described above. Multiple comparison procedures will be described in greater detail in the SAP.

#### **14.4 Immunogenicity**

Analysis of total and neutralizing antibody response and other immunological parameters will be primarily descriptive and involve both inter-subject and intra-subject comparisons.

#### **14.5 Pharmacodynamic Analyses**

Plasma FVIII protein concentrations and FVIII activities determined over the course of the study will primarily be evaluated and summarized with descriptive statistical measures (eg, mean, standard deviation, CV%, min, median, max).

#### **14.6 Safety Analysis**

The Medical Dictionary for Regulatory Activities terminology (MedDRA) will be used by the Sponsor to assign system organ class and preferred term classification to events and diseases, based on the original terms entered on the eCRF.

All AEs will be coded using the current version of MedDRA. The incidence of AEs will be summarized by system organ class, preferred term, relationship to study drug, and severity. A by-subject listing will be provided for those subjects who experience a serious AE (SAE), including death, or experience an AE associated with early withdrawal from the study or study drug.

Clinical laboratory data will be summarized by the type of laboratory test. For each clinical laboratory test, descriptive statistics will be provided on Baseline as well as all subsequent visits. Descriptive statistics for physical examination results and vital signs will also be provided.

Detailed statistical methods will be provided in the SAP.





## 14.7 Determination of Sample Size

Approximately one hundred and thirty (130) subjects may be dosed in the study. The sample size for this study is based on clinical and statistical considerations in order to provide sufficient data to assess both safety and efficacy of BMN 270.

For the primary endpoint, a sample size of 130 will provide at least 95% power to demonstrate that the change in hFVIII activity during Weeks 49-52 from baseline is greater than 0, assuming an effect size of 0.6, using a one-sample t-test with a 2-sided significance level of 0.05. The effect size of 0.6 is assumed based on Study 270-201 data. In Study 270-201 cohort 6E13, the mean (SD) of FVIII activity (IU/dL) at Week 52 (based on median values in a 4-week window around Week 52) were estimated as 103.8 (62.4), with a 95% confidence interval for the mean of (46.1, 161.5). Using the lower limit of the confidence interval and assuming a baseline value of 1 (the largest value allowed per the study's inclusion/exclusion criteria), the effect size of change from baseline is approximately 0.7. For the sample size calculation, an effect size of 0.6 is assumed.

For the secondary endpoints, the analysis will be performed utilizing exogenous FVIII use and bleeding episode data from the 110 subjects whose baseline data will be prospectively collected for approximately 6 months in the non-interventional study 270-902, prior to their enrollment in Study 270-301. An analytic sample size of 110 will provide at least 95% power to demonstrate that the change in the annualized utilization (IU/kg) of exogenous FVIII replacement therapy during Week 5 to Week 52 post-BMN 270 infusion from the baseline is less than 0, assuming an effect size of 0.6 conservatively, using one-sample t-test with a 2-sided significance level of 0.05.

For the analytic sample size calculation of the second secondary endpoint, ABR, it is assumed that the pre- and post-BMN 270 infusion population mean ABRs are 3.5 and 1 respectively, and the distribution of ABRs is negative binomial distribution with a dispersion parameter of 2.2. Given the underlying negative binomial distributions, the standard deviations of the pre- and post-BMN 270 infusion ABRs are calculated as 7.8 and 1.8 respectively. The mean (SD) of the change from the pre- to post-BMN 270 infusion ABRs are calculated as -2.5 (8) assuming the correlation between pre- and post-BMN 270 infusion ABRs is zero. Under this assumption, an analytic sample size of 110 will also have at least 95% power to demonstrate that the change in the annualized number of bleeding episodes requiring exogenous FVIII replacement treatment (ABR) during Week 5 to Week 52 of the study post-BMN 270 infusion from the baseline ABR is less than 3.5 (non-inferiority margin), using a one-sample t-test with a 2-sided significance level of 0.05. Under the same assumptions, a sample size of 110 will have approximately 90% power to



demonstrate that the change is less than 0, ie, superiority of BMN 270 against FVIII prophylaxis.

Overall, the planned sample size will have greater than 80% power for testing the primary and secondary efficacy endpoints hierarchically at the final analysis with a 2-sided significance level of 0.05.

#### **14.8 Analysis Populations**

The intention-to-treat (ITT) population is defined as all subjects who receive BMN 270 infusion, and the modified intention-to-treat (mITT) population is defined as subjects who receive BMN 270 infusion and are HIV-negative. The mITT population will be used for the primary efficacy analysis and ITT will be used for the supportive efficacy analysis. The ITT population will also be used for the safety analysis.

#### **14.9 Changes in the Conduct of the Study or Planned Analyses**

Only BioMarin may modify the protocol. Any change in study conduct considered necessary by the Investigator will be made only after consultation with BioMarin, who will then issue a formal protocol amendment to implement the change. The only exception is when an Investigator considers that a subject's safety is compromised without immediate action. In these circumstances, immediate approval of the chairman of the IRB/IEC/REB must be sought, and the Investigator should inform BioMarin and the full IRB/IEC/REB within 2 working days after the emergency occurs.

With the exception of minor administrative or typographical changes, the IRB/IEC/REB must review and approve all protocol amendments. Protocol amendments that have an impact on subject risk or the study objectives, or require revision of the ICF, must receive approval from the IRB/IEC/REB prior to their implementation.

When a protocol amendment substantially alters the study design or the potential risks or burden to subjects, the ICF will be amended and approved by BioMarin and the IRB/IEC/REB, and all active subjects must again provide informed consent.



---

## 15 DATA MONITORING COMMITTEE

An independent DMC will be convened for this study. The duties of the DMC will include:

- Conducting an ongoing review of individual subject safety and efficacy data during the study.
- Recommending whether to enroll subjects at a different dose level (not to exceed 6E13 vg/kg) based on emerging data from 270-301 and the overall risk/benefit analysis of BMN 270.
- Reviewing ongoing safety and efficacy data for comparability of drug manufacturing lots within 270-301 and between 270-201 and 270-301.
- Making other recommendations on the conduct and reporting of the trial based on their evaluation of clinical data.

Details on the composition of the committee, frequency of meetings, and other committee functions and parameters are included in the DMC Charter and in the Statistical Analysis Plan (SAP).



## **16 COSTS, COMPENSATION, AND SUBJECT INJURY**

There will be no charge to study subjects to be in this study. BioMarin will pay all costs of tests, procedures, and treatments that are part of this study. In addition, after IRB/IEC/REB approval, BioMarin may reimburse the reasonable cost of travel for study-related visits in accordance with BioMarin's travel and reimbursement policy. BioMarin will not pay for any hospitalizations, tests, or treatments for medical problems of any sort related solely to the study subject's disease. Costs associated with such hospitalizations, tests, and treatments should be billed and collected in the way that such costs are usually billed and collected outside the study.

The Investigator should contact BioMarin immediately upon notification that a study subject has been injured by the study drug or by procedures performed as part of the study. Any subject who experiences a study-related injury should be instructed by the Investigator to seek immediate medical treatment at a pre-specified medical institution if possible, or at the closest medical treatment facility if necessary. The subject should be given the name of a person to contact to seek further information about, and assistance with, treatment for study-related injuries. The treating physician should bill the subject's health insurance company or other third party payer for the cost of this medical treatment. If the cost of the medical treatment is not covered by health insurance or another third party that usually pays these costs, then either BioMarin or the institution may pay for reasonable and necessary medical services to treat the injuries caused by the study drug or study procedures. In some jurisdictions, BioMarin is obligated by law to pay for study-related injuries without prior recourse to third party payer billing and/or regardless of fault. If this is the case, BioMarin will comply with the law.



---

## 17 CASE REPORT FORMS AND SOURCE DOCUMENTS

Electronic case report forms will be provided for each subject. The Investigator must review and electronically sign the completed eCRF casebook to verify its accuracy.

eCRFs must be completed using a web-based application developed and validated. Study site personnel will be trained on the application and will enter the clinical data from source documentation. Unless explicitly allowed in the eCRF instructions, blank data fields are not acceptable.

In the event of an entry error, or if new information becomes available, the value will be corrected by deselecting the erroneous response and then selecting or entering the factual response. In compliance with ICH GCP Guidelines and 21 CFR Part 11, the system will require the personnel making the correction to enter a reason for changing the value. The documented audit trail will include the reason for the change, the original value, the new value, the time of the correction and the identity of the operator.

BioMarin's policy is that study data on the eCRFs must be verifiable to the source data, which necessitates access to all original recordings, laboratory reports, and subject records. In addition, all source data should be attributable (signed and dated). The Investigator must therefore agree to allow direct access to all source data. Subjects must also allow access to their medical records, and subjects will be informed of this and will confirm their agreement when giving informed consent. If direct source document verification of study data by the site monitor is prohibited by institutional policy or local law, then the Investigator must make available facilities and/or personnel to allow GCP-compliant source verification to occur. Examples of such methods include certified copies of records which have study data visible but sensitive information redacted, or other GCP-compliant means agreed between the Investigator and the Sponsor.

A site monitor designated by BioMarin will compare the eCRFs with the original source documents at the study site and evaluate them for completeness and accuracy before designating them as "Source Data Verified" (SDV). If an error is discovered at any time or a clarification is needed, the site monitor, or designee, will create an electronic query on the associated field. Site personnel will then answer the query by either correcting the data or responding to the query. The site monitor will then review the response and determine either to close the query or re-query the site if the response does not fully address the question. This process is repeated until all open queries have been answered and closed.

Before a subject's eCRF casebook can be locked, data fields must be source data verified and all queries closed. Refer to the Study Monitoring Plan for details on which fields must be



source data verified. The Investigator will then electronically sign the casebook, specifying that the information on the eCRFs is accurate and complete. The Data Manager, or designee, will then set the status of the forms, visits, and the entire casebook to Locked. Upon completion of the CSR, an electronic copy of each site's casebooks will be copied to a compact disk (CD) and sent to each site for retention with other study documents.



---

## 18 STUDY MONITORING AND AUDITING

Qualified individuals designated by BioMarin will monitor all aspects of the study according to GCP and standard operating procedures for compliance with applicable government regulations. The Investigator agrees to allow these monitors direct access to the clinical supplies, dispensing, and storage areas and to the clinical files, including original medical records, of the study subjects, and, if requested, agrees to assist the monitors. The Investigator and staff are responsible for being present or available for consultation during routinely scheduled site visits conducted by BioMarin or its designees.

Members of BioMarin's GCP Compliance Department or designees may conduct an audit of a clinical site at any time before, during, or after completion of the study. The Investigator will be informed if an audit is to take place and advised as to the scope of the audit. Representatives of the FDA or other Regulatory Agencies may also conduct an audit of the study. If informed of such an inspection, the Investigator should notify BioMarin immediately. The Investigator will ensure that the auditors have access to the clinical supplies, study site facilities, original source documentation, and all study files.



## 19 RETENTION OF RECORDS

The Investigator must retain all study records required by BioMarin and by the applicable regulations in a secure and safe facility. The Investigator must consult a BioMarin representative before disposal of any study records, and must notify BioMarin of any change in the location, disposition or custody of the study files. The Investigator /institution must take measures to prevent accidental or premature destruction of essential documents, that is, documents that individually and collectively permit evaluation of the conduct of a study and the quality of the data produced, including paper copies of study records (eg, subject charts) as well as any original source documents that are electronic as required by applicable regulatory requirements.

All study records must be retained for at least 2 years after the last approval of a marketing application in the US or an ICH region and until (1) there are no pending or contemplated marketing applications in the U.S. or an ICH region or (2) at least 2 years have elapsed since the formal discontinuation of clinical development of the IP. The Investigator /institution should retain subject identifiers for at least 15 years after the completion or discontinuation of the study. Subject files and other source data must be kept for the maximum period of time permitted by the hospital, institution or private practice, but not less than 15 years. These documents should be retained for a longer period, however, if required by the applicable regulatory requirements or by a BioMarin agreement. BioMarin must be notified and will assist with retention should Investigator /institution be unable to continue maintenance of subject files for the full 15 years. It is the responsibility of BioMarin to inform the Investigator /institution as to when these documents no longer need to be retained.





## **20 USE OF INFORMATION AND PUBLICATION**

BioMarin recognizes the importance of communicating medical study data and therefore encourages the publication of these data in reputable, peer-reviewed scientific journals and at seminars or conferences. The details of the processes of producing and reviewing reports, manuscripts, and presentations based on the data from this study will be described in the Clinical Trial Agreement between BioMarin and the Investigator/Institution. Consideration for authorship of all publications will be based on compliance with the Uniform Requirements for Manuscripts Submitted to Biomedical Journals (“Uniform Requirements”) of the International Committee of Medical Journal Editors (ICMJE) ([http://www.icmje.org/ethical\\_1author.html](http://www.icmje.org/ethical_1author.html)) and good publication practices (GPP).



---

## 21 REFERENCES

- Batts KP & Ludwig J. Chronic hepatitis: an update on terminology and reporting. *Am J Surg Pathol* 19:1409-1417. 1995.
- Bedossa P, Pynard T, French METAVIR Cooperative Study Group. An algorithm for grading activity in chronic hepatitis C. *Hepatology* 24;289-293. 1996.
- Berntorp E, Dolan G, Hay C, Linari S et al. European retrospective study of real-life haemophilia treatment. *Haemophilia*. 2017;23(1):105-114.
- Berntorp E, Peake I, Budde U, Laffan M et. al. von Willebrand's disease: a report from a meeting in the Aland islands. *Haemophilia* 18 Suppl 6, 1-13. 2012.
- Brooks R. EuroQol: the current state of play. *Health Policy*. 1996;37:53-72.
- Chai-Adisaksopha C, Skinner M, Curtis R, et al. Psychometric Properties of the Patient Reported Outcomes, Burdens and Experiences (PROBE) Questionnaire. *Blood*. 2017;130:5645.
- EuroQol Group. EuroQol – a new facility for the measurement of health-related quality of life. *Health Policy*. 1990;16:199-208.
- George LA, Sullivan S, Teitel J, Cuker A et al. Preliminary results of a phase 1/2 trial of SPK-9001, a hyperactive FIX variant delivered by a novel capsid, demonstrate consistent factor IX activity levels at the lowest dose cohort. *Haemophilia* 22[Suppl. 4], 151-152. 2016.
- Hay CR, DiMichele DM. The principal results of the International Immune Tolerance Study: a randomized dose comparison  
12. *Blood* 119[6], 1335-1344. 2012.
- Haemo-QoL Study Group. Scoring Manual. Available at: <http://haemoqol.de/scoring/manual>. Last accessed 28 July 2017.
- Kaufman RJ, Powell JS. Molecular approaches for improved clotting factors for hemophilia 1. *Blood* 122[22], 3568-3574. 2013.
- Manno CS, Pierce GF, Arruda VR, Glader B et. al. Successful transduction of liver in hemophilia by AAV-Factor IX and limitations imposed by the host immune response. *Nat Med* 12[3], 342-347. 2006.



Miesbach W, Tangelder M, Klamroth R, Schutgens R et al. Updated results from a dose escalating study in adult patients with haemophilia B with AMT-060 (AAV5-hFIX) gene therapy. *Haemophilia* 22[Suppl. 4], 151-152. 2016.

Mingozzi F and High KA. Immune responses to AAV vectors: overcoming barriers to successful gene therapy. *Blood* 122[1], 23-36. 2013.

Nathwani AC, Reiss UM, Tuddenham EG, Rosales C et. al. Long-term safety and efficacy of factor IX gene therapy in hemophilia B. *N Engl J Med* 371[21], 1994-2004. 2014.

Nathwani AC, Rosales, C, McIntosh J, Rastegarlarlari G et. al. Long-term safety and efficacy following systemic administration of a self-complementary AAV vector encoding human FIX pseudotyped with serotype 5 and 8 capsid proteins. *Mol Ther* 19[5], 876-885. 2011.

Nathwani AC, Tuddenham EG. Epidemiology of coagulation disorders. *Baillieres Clin Haematol* 5[2], 383-439. 1992.

Pasi KJ, Rangarajan S, Kim B et al. Achievement of Normal Circulating Factor VIII Activity Following BMN 270 AAV5-FVIII Gene Transfer: Interim, Long-Term Efficacy and Safety Results from a Phase 1/2 Study in Patients with Severe Hemophilia A. *Blood* 130[Suppl. 1], 603. 2017.

Rangarajan S, Kim B, Lester W et al. Achievement of normal factor VIII activity following gene transfer with valoctocogene roxaparvovec (BMN 270): Long- term efficacy and safety results in patients with severe hemophilia A. *Haemophilia* 24[Suppl. 5], 65. 2018

Reilly M. WPAI Scoring. 2002. Available at: [http://www.reillyassociates.net/WPAI\\_Scoring.html](http://www.reillyassociates.net/WPAI_Scoring.html). Last accessed 28 July 2017.

Recht M, Neufeld EJ, Sharma VR, Solem CT et al. Impact of Acute Bleeding on Daily Activities of Patients with Congenital Hemophilia with Inhibitors and Their Caregivers and Families: Observations from the Dosing Observational Study in Hemophilia (DOSE). *Value in Health*. 2014;17:744-748.

Rentz A, Flood E, Altisent C, Bullinger M et al. Cross-cultural development and psychometric evaluation of a patient-reported health-related quality of life questionnaire for adults with haemophilia. *Haemophilia* 2008;14(5):1023-34.

Sampson HA, Muñoz-Furlong A, Campbell RL, et al. Second symposium on the definition and management of anaphylaxis: summary report—second National Institute of Allergy and Infectious Disease/Food Allergy and Anaphylaxis Network symposium. *J Allergy Clin Immunol* 2006;117:391-397.



---

Srivastava A, Brewer AK, Mauser-Bunschoten EP, Key NS et. al. Guidelines for the management of hemophilia 128. *Haemophilia* 19[1], e1-47. 2013.

Stonebraker JS, Brooker M, Amand RE, Farrugia A et. al. A study of reported factor VIII use around the world. *Haemophilia* 16[1], 33-46. 2010.

United States Department of Health and Human Services. Guidelines for the Use of Antiretroviral Agents in HIV-1-Infected Adults and Adolescents. 2014. Available at <https://aidsinfo.nih.gov/guidelines/html/1/adult-and-adolescent-arv-guidelines/458/plasma-hiv-1-rna--viral-load--and-cd4-count-monitoring>. Last accessed 28 July 2017.

Van Genderen FR, Westers P, Heijnen L, De Kleijn P et al. Measuring patients' perceptions on their functional abilities: validation of the Haemophilia Activities List. *Haemophilia*. 2006;12:36-46.

Wiens BL, Dmitrienko A. The fallback procedure for evaluating a single family of hypotheses. *J Biopharm Stat*. 2005; 15:929-942.



---

## 22 INVESTIGATOR RESPONSIBILITIES

### 22.1 Conduct of Study and Protection of Human Patients

In accordance with FDA Form 1572 and/or principles of ICH E6 GCP, the Investigator will ensure that:

- He or she will conduct the study in accordance with the relevant, current protocol and will only make changes in a protocol after notifying the sponsor, except when necessary to protect the safety, rights, or welfare of subjects.
- He or she will personally conduct or supervise the study.
- He or she will inform any potential subjects, or any persons used as controls, that the drugs are being used for investigational purposes, and he or she will ensure that the requirements relating to obtaining informed consent in 21 CFR Part 50 and/or ICH E6 sections 2.9 and 4.8 are met. As well, he or she will ensure that IRB/IEC review and approval in 21 CFR Part 56 and/or ICH E6 section 2.6 are met.
- He or she will report to the sponsor adverse experiences that occur in the course of the investigation in accordance with 21 CFR 312.64 and/or ICH E6 Section 4.11.
- He or she has read and understands the information in the Investigator's Brochure, including potential risks and side effects of the drug.
- His or her staff and all persons who assist in the conduct of the study are informed about their obligations in meeting the above commitments
- Adequate and accurate records in accordance with 21 CFR 312.62 and/or ICH E6 section 4.9 are kept, and those records are available for inspection in accordance with 21 CFR 312.68 and/or ICH E6 section 4.9.7.
- The IRB/EC/REB complies with the requirements of 21 CFR Part 56, ICH E6 Section 3.0, and other applicable regulations, and conducts initial and ongoing reviews and approvals of the study. He or she will also ensure that any change in research activity and all problems involving risks to human subjects or others are reported to the IRB/EC/REB. Additionally, he or she will not make any changes in the research without IRB/EC/REB approval, except where necessary to eliminate apparent immediate hazards to human subjects.
- He or she agrees to comply with all other requirements regarding the obligations of clinical Investigators and all other pertinent requirements in 21 CFR Part 312 and/or ICH E6.



**23 SIGNATURE PAGE**

**Protocol Title:** A Phase 3 Open-Label, Single Arm Study To Evaluate The Efficacy and Safety of BMN 270, an Adeno-Associated Virus Vector-Mediated Gene Transfer of Human Factor VIII in Hemophilia A Patients with Residual FVIII Levels  $\leq$  1 IU/dL Receiving Prophylactic FVIII Infusions

**Protocol Number:** 270-301 Amendment 4

I have read the forgoing protocol and agree to conduct this study as outlined. I agree to conduct the study in compliance with all applicable regulations and guidelines, including ICH E6, as stated in the protocol, and other information supplied to me.

\_\_\_\_\_  
Investigator Signature Date

Printed name: \_\_\_\_\_

**Accepted for the Sponsor:**



\_\_\_\_\_  
Medical Monitor Signature Date

Printed name: PI Clinical Sciences



---

**24 APPENDIX 1: SAMPSON'S ANAPHYLAXIS CRITERIA**

According to the National Institute of Allergy and Infectious Disease/Food Allergy and Anaphylaxis Network (NIAID/FAAN) Second Symposium on the definition and management of anaphylaxis, anaphylaxis is highly likely when any one of the following 3 criteria are fulfilled:

1. Acute onset of an illness (minutes to several hours) with involvement of the skin, mucosal tissue, or both (eg, generalized hives, pruritus or flushing, swollen lips-tongue-uvula)  
*AND AT LEAST ONE OF THE FOLLOWING*
  - a. Respiratory compromise (eg, dyspnea, wheeze-bronchospasm, stridor, reduced peak expiratory flow [PEF], hypoxemia)
  - b. Reduced blood pressure (BP) or associated symptoms of end-organ dysfunction (eg, hypotonia [collapse], syncope, incontinence)
2. Two or more of the following that occur rapidly after exposure to a likely allergen for that patient (minutes to several hours):
  - a. Involvement of the skin-mucosal tissue (eg, generalized hives, itch-flush, swollen lips-tongue-uvula)
  - b. Respiratory compromise (eg, dyspnea, wheeze-bronchospasm, stridor, reduced PEF, hypoxemia)
  - c. Reduced BP or associated symptoms (eg, hypotonia [collapse], syncope, incontinence)
  - d. Persistent gastrointestinal symptoms (eg, crampy abdominal pain, vomiting)
3. Reduced BP after exposure to known allergen for that patient (minutes to several hours):
  - a. Infants and children: low systolic blood pressure (age specific) or greater than 30% decrease in systolic BP
  - b. Adults: systolic BP of less than 90 mmHg or greater than 30% decrease from that person's baseline.

Source: [Sampson, 2006](#).





## 25 PROTOCOL AMENDMENT TEXT REVISIONS

The following table summarizes the revisions made to the protocol and relates the changes to the appropriate rationale (see pages 2-3). Added text is indicated by underlined font and deleted text is indicated by ~~striketrough~~ font.

| Section No./Title                 | Revision  | Rationale |
|-----------------------------------|---|-----------|
| Synopsis/Study Design and Plan    | <p>An interim analysis is planned after 20 <del>evaluable-treated</del> <u>evaluable</u> HIV-negative subjects have completed the Week 26 visit. Data will be reviewed by the DMC, based on the statistical analysis plan, and a formal recommendation will be made whether to continue the study as designed.</p> <p>...</p> <p>Subjects who do not respond to BMN 270 treatment (ie, treatment failure, manifesting as either failure to achieve FVIII activity <math>\geq</math> 5 IU/dL by Week 52 or inability to maintain independence from prophylactic FVIII replacement therapy due to joint bleeding episodes, in the judgment of the Investigator) may, at the Investigator's discretion and after discussion with the Medical <u>Monitor</u> or <u>Sponsor-designated Data Monitor</u>, follow an abbreviated visit schedule after Week 52 of the study by attending only the Q12W and End of Year visits during Years 2-5.</p> | 4         |
| Synopsis/Statistical Methods      | <p>An interim analysis is planned after approximately 20 <del>evaluable-treated</del> <u>evaluable</u> HIV-negative subjects have completed the Week 26 visit (or have discontinued study participation prior to Week 26). The primary efficacy endpoint for the interim analysis involves hFVIII activity, as measured by chromogenic substrate assay, achieved post-BMN 270 infusion, as detailed in the statistical analysis plan (SAP).</p>   | 4         |
| 9.1/Overall Study Design and Plan | <p>An interim analysis is planned after 20 <del>evaluable-treated</del> <u>evaluable</u> HIV-negative subjects have completed the Week 26 visit.</p> <p>...</p> <p>Subjects who do not respond to BMN 270 treatment (ie, treatment failure, manifesting as either failure to achieve FVIII activity <math>\geq</math> 5 IU/dL by Week 52 or inability to maintain independence from prophylactic FVIII replacement therapy due to joint bleeding episodes, in the judgment of the Investigator) may, at the Investigator's discretion and after discussion with the Medical <u>Monitor</u> or <u>Sponsor-designated Data Monitor</u>, follow an abbreviated visit schedule after Week 52 of the study by attending only the Q12W and End of Year visits during Years 2-5.</p>   | 4         |
| Table 9.1.1 through Table 9.1.5   | The Direct Thrombin Activity assay assessment has been removed.   | 3         |





| Section No./Title | Revision   | Rationale |
|-------------------|--|-----------|
| Table 9.1.1 notes | <p><sup>c</sup> Refer to Table 9.7.8.2.1 for laboratory assessments to be included, and to Table 9.7.8.3.1 for liver tests. <u>ABO blood typing assessment should be performed as part of the hematology assessment (at Baseline, or at another regularly scheduled visit prior to the end of the subject's participation in the study).</u></p> <p><sup>g</sup> Blood samples will be collected to evaluate biochemical, molecular, cellular, <del>ABO blood typing,</del> and genetic/genomic aspects relevant to hemophilia A, coagulation, and/or AAV gene transfer, and to develop assays used for these evaluations. Subjects may choose to opt out of the exploratory genetic/genomic research being done to study or try to discover genes that are not yet known to be associated with hemophilia A. While exploratory samples will be collected at the time points indicated above, testing of these samples (including those for TGA assay, <del>Direct Thrombin Activity test,</del> and any other exploratory assessments) will be performed only as deemed necessary by the Sponsor.</p>   | 3, 4      |
| Table 9.1.2 notes | <p><sup>c</sup> Blood samples will be collected to evaluate biochemical, molecular, cellular, and genetic/genomic aspects relevant to hemophilia A, coagulation, and/or AAV gene transfer, and to develop assays used for these evaluations. Subjects may choose to opt out of the exploratory genetic/genomic research being done to study or try to discover genes that are not yet known to be associated with hemophilia A. While exploratory samples will be collected at the time points indicated above, testing of these samples (including those for TGA assay, <del>Direct Thrombin Activity test,</del> and any other exploratory assessments) will be performed only as deemed necessary by the Sponsor.</p> <p><sup>g</sup> <u>For subjects who have entered 270-301 following participation in 270-902, the scheduled visits at Week 5, Week 7, Week 9, Week 11, Week 13, and Week 15 may be performed by a mobile nursing (MN) professional at the subject's home or another suitable location (if the subject has given written informed consent to participate in MN visits), or at the site as a shortened lab draw-only visit. The MN service or site will collect blood samples at these visits. For site lab draw-only visits, sites will contact the subject via phone call or e-mail to collect information regarding adverse events, changes to concomitant medications, bleeding episodes, and FVIII use. For MN visits, the service will collect this information. The physical examination and vital signs assessments listed in the Schedule of Events will not be performed at these MN or lab draw-only visits for subjects who have entered 270-301 following participation in 270-902.</u></p> | 1, 3      |
| Table 9.1.3 notes | <p><sup>c</sup> Blood samples will be collected to evaluate biochemical, molecular, cellular, and genetic/genomic aspects relevant to hemophilia A, coagulation, and/or AAV gene transfer, and to develop assays used for these evaluations. Subjects may choose to opt out of the exploratory genetic/genomic research being done to study or try to discover genes that</p>  | 1, 3      |



| Section No./Title | Revision  | Rationale |
|-------------------|---|-----------|
|                   | <p>are not yet known to be associated with hemophilia A. While exploratory samples will be collected at the time points indicated above, testing of these samples (including those for TGA assay, <del>Direct Thrombin Activity test</del>, and any other exploratory assessments) will be performed only as deemed necessary by the Sponsor.</p> <p><sup>f</sup> For subjects who have entered 270-301 following participation in 270-902, the scheduled visits at Week 17, Week 19, Week 21, Week 23, Week 25, Week 27, Week 29, Week 30, and Week 31 may be performed by a mobile nursing (MN) professional at the subject's home or another suitable location (if the subject has given written informed consent to participate in MN visits), or at the site as a shortened lab draw-only visit. The MN service or site will collect blood samples at these visits. For site lab draw-only visits, sites will contact the subject via phone call or e-mail to collect information regarding adverse events, changes to concomitant medications, bleeding episodes, and FVIII use. For MN visits, the service will collect this information. The physical examination and vital signs assessments listed in the Schedule of Events will not be performed at these MN or lab draw-only visits for subjects who have entered 270-301 following participation in 270-902.</p>  |           |
| Table 9.1.4 notes | <p><sup>d</sup> Blood samples will be collected to evaluate biochemical, molecular, cellular, and genetic/genomic aspects relevant to hemophilia A, coagulation, and/or AAV gene transfer, and to develop assays used for these evaluations. Subjects may choose to opt out of the exploratory genetic/genomic research being done to study or try to discover genes that are not yet known to be associated with hemophilia A. While exploratory samples will be collected at the time points indicated above, testing of these samples (including those for TGA assay, <del>Direct Thrombin Activity test</del>, and any other exploratory assessments) will be performed only as deemed necessary by the Sponsor.</p> <p><sup>e</sup> For subjects who have entered 270-301 following participation in 270-902, the scheduled visits at Week 33, Week 34, Week 35, Week 38, Week 42, Week 46, and Week 50 may be performed by a mobile nursing (MN) professional at the subject's home or another suitable location (if the subject has given written informed consent to participate in MN visits), or at the site as a shortened lab draw-only visit. The MN service or site will collect blood samples at these visits. For site lab draw-only visits, sites will contact the subject via phone call or e-mail to collect information regarding adverse events, changes to concomitant medications, bleeding episodes, and FVIII use. For MN visits, the service will collect this information. The physical examination and vital signs assessments listed in the Schedule of Events will not be performed at these MN or lab draw-only visits for subjects who have entered 270-301 following participation in 270-902.</p> | 1, 3      |



| Section No./Title   | Revision  | Rationale |
|---|---|-----------|
| Table 9.1.5 notes   | <p>° Blood samples will be collected to evaluate biochemical, molecular, cellular, and genetic/genomic aspects relevant to hemophilia A, coagulation, and/or AAV gene transfer, and to develop assays used for these evaluations. Subjects may choose to opt out of the exploratory genetic/genomic research being done to study or try to discover genes that are not yet known to be associated with hemophilia A. While exploratory samples will be collected at the time points indicated above, testing of these samples (including those for TGA assay, <del>Direct Thrombin Activity test</del>, and any other exploratory assessments) will be performed only as deemed necessary by the Sponsor.</p> | 3         |
| 9.7.2.1/FVIII Activity  | <p>Subjects who do not respond to BMN 270 treatment (ie treatment failure, manifesting as either failure to achieve FVIII activity <math>\geq</math> 5 IU/dL by Week 52 or inability to maintain independence from prophylactic FVIII replacement therapy due to joint bleeding episodes, in the judgment of the Investigator) may, at the Investigator's discretion and after discussion with the Medical Monitor or Sponsor-designated Data Monitor, follow an abbreviated visit schedule after Week 52 of the study by attending only the Q12W and End of Year visits during Years 2-5.</p>  | 4         |
| 9.7.7/Exploratory Assessments   | <p>Blood samples will be collected from subjects at the time points indicated in Table 9.1.1, Table 9.1.2, Table 9.1.3, Table 9.1.4, and Table 9.1.5 to evaluate biochemical, molecular, cellular, <del>ABO blood typing</del>, and genetic/genomic aspects relevant to hemophilia A, coagulation, and/or AAV gene transfer, and to develop assays used for these evaluations. Subjects may choose to opt out of the exploratory genetic/genomic research being done to study or try to discover genes that are not yet known to be associated with hemophilia A.</p>   | 4         |
| 9.7.8.2/Clinical Laboratory Assessments                                   | <p><u>For subjects who have enrolled in 270-301 following participation in 270-902, MN visits may also be available during Year 1 at Weeks 5, 7, 9, 11, 13, 15, 17, 19, 21, 23, 25, 27, 29, 30, 31, 33, 34, 35, 38, 42, 46, and 50 (as indicated in the Schedule of Events).</u></p>  | 1         |
| Table 9.7.8.2.1   | <p>ABO blood typing has been added to this table, with the note:</p> <p><u>*ABO blood typing assessment should be performed as part of the hematology assessment (at Baseline, or at another regularly scheduled visit prior to the end of the subject's participation in the study).</u></p>   | 4         |
| 9.7.8.3/Vital Signs, Physical Examinations, and Other Safety Observations | <p>A complete physical examination is necessary during Screening/Baseline, at Week 26 and 52 and every 52 weeks thereafter; at other visits, brief physical examinations may be performed at the discretion of the Investigator based on the subject's clinical condition. Particular attention should be given to signs of bleeding, as well as assessing possible hemarthroses. <u>During Year 1, at visits where the MN services are used or shortened lab draw-only visits are conducted</u></p>  | 1         |



| Section No./Title                 | Revision  | Rationale |
|-----------------------------------|---|-----------|
|                                   | <u>at the sites, the physical examination and vital signs assessments indicated in the Schedule of Events will not be performed.</u>  |           |
| 10.2.1/Events of Special Interest | The following EOSI need to be reported to the Sponsor within 24 hours of site awareness, irrespective of seriousness, severity or causality: <ul style="list-style-type: none"> <li>• <u>Development of anti-FVIII inhibitory antibodies (inhibitors)</u></li> </ul>  | 2         |
| 12.3/Baseline Visit               | Baseline values will be recorded from 1 to 7 days prior to the treatment visit. The following procedures will be performed during the Baseline Period: <ul style="list-style-type: none"> <li>• Blood chemistry, hematology, and coagulation tests (refer to Table 9.7.8.2.1) <ul style="list-style-type: none"> <li>○ <u>ABO blood typing assessment should be performed as part of the hematology assessment (at Baseline, or at another regularly scheduled visit prior to the end of the subject's participation in the study).</u></li> </ul> </li> <li>• <del>Direct Thrombin test</del></li> </ul> | 3, 4      |
| 12.4/Day 1 Visit                  | There will be one treatment visit for each subject. Subjects will remain in the clinic for at least 8 hours for the BMN 270 Infusion Visit. The following procedures will be performed during the BMN 270 Infusion Visit: <ul style="list-style-type: none"> <li>• <u>Exploratory biomarker assessments</u></li> </ul>  | 4         |
| 12.5/Weeks 1-26                   | After BMN 270 has been infused, subjects will return to the study site every week ( $\pm$ 48 hours) during Weeks 1-26. <u>For subjects who have enrolled in 270-301 following participation in 270-902, optional MN services or shortened lab draw-only site visits may be conducted for the visits at Week 5, Week 7, Week 9, Week 11, Week 13, Week 15, Week 17, Week 19, Week 21, Week 23, and Week 25.</u><br><u>At the Weeks 1-26 visits, <del>when</del> the following procedures will be completed:</u>  | 1         |
| 12.5.1/Once per Week (Weeks 1-26) | The following procedures will be performed at one visit per week from Weeks 1 through 26: <ul style="list-style-type: none"> <li>• Brief physical examination (complete physical examination at Week 26) <ul style="list-style-type: none"> <li>○ <u>For visits where a MN service is being used or a lab draw-only site visit is conducted, physical examination will not be performed.</u></li> </ul> </li> </ul>   | 1         |



| Section No./Title   | Revision  | Rationale |
|---|---|-----------|
|   | <ul style="list-style-type: none"> <li>• Assessment of Adverse Events and Concomitant Medications (including review of subject diary for bleeding and FVIII use) <ul style="list-style-type: none"> <li>○ <u>For visits where a MN service is being used, the service will contact the subject via e-mail or phone call to collect information regarding adverse events, changes to concomitant medications, bleeding episodes, and FVIII use.</u></li> </ul> </li> <li>• Vital Signs <ul style="list-style-type: none"> <li>○ <u>For visits where a MN service is being used or a lab draw-only site visit is conducted, vital signs will not be performed.</u></li> </ul> </li> </ul> |           |
| 12.5.10/Weeks 6, <del>13</del> <u>12</u> , 16, 20, 24, and 26 | At Weeks 6, <del>13</del> <u>12</u> , 16, 20, 24, and 26, the following procedures will be performed: <ul style="list-style-type: none"> <li>• Exploratory biomarker assessments</li> </ul>   | 1         |
| 12.5.11/Weeks 12 and 26                                       | At Weeks 12 and 26, the following procedures will be performed: <ul style="list-style-type: none"> <li>• Urine Tests (refer to Table 9.7.8.2.1)</li> <li>• <u>VWF:Ag</u></li> </ul>   | 1         |
| <del>12.5.12/Week 13 and 26</del>                             | <del>At Weeks 13 and 26, the following procedures will be performed:</del> <ul style="list-style-type: none"> <li><del>• Direct Thrombin test</del></li> <li>• <u>VWF:Ag</u></li> </ul>   | 1, 3      |
| 12.6/Weeks 27-52  | During Weeks 27-36, subjects will return to the study site weekly ( $\pm$ 48 hours). During Weeks 37-52, subjects will return to the study site every 2 weeks (Week 38, 40, 42, 44, 46, 48, 50, and 52) ( $\pm$ 1 week). <u>For subjects who have enrolled in 270-301 following participation in 270-902, optional MN services or shortened lab draw-only site visits may be conducted at Week 27, Week 29, Week 30, Week 31, Week 33, Week 34, Week 35, Week 38, Week 42, Week 46, and Week 50.</u>  | 1         |
| 12.6.1/Every Visit  | At every visit (Weeks 27-36, 38, 40, 42, 44, 46, 48, 50, and 52), the following procedures will be performed: <ul style="list-style-type: none"> <li>• Physical examination</li> </ul>  | 1         |



| Section No./Title  | Revision  | Rationale |
|--|---|-----------|
|  | <ul style="list-style-type: none"> <li>○ Brief physical examination should be performed at all weeks except Week 26, when a complete physical examination should be performed</li> <li>○ <u>For visits where a MN service is being used or a lab draw-only site visit is conducted, physical examination will not be performed.</u></li> <li>● Assessment of Adverse Events and Concomitant Medications (including review of subject diary for bleeding and FVIII use) <ul style="list-style-type: none"> <li>○ <u>For visits where a MN service is being used, the service will contact the subject via e-mail or phone call to collect information regarding adverse events, changes to concomitant medications, bleeding episodes, and FVIII use.</u></li> </ul> </li> <li>● Vital Signs <ul style="list-style-type: none"> <li>○ <u>For visits where a MN service is being used or a lab draw-only site visit is conducted, vital signs will not be performed.</u></li> </ul> </li> </ul> |           |
| 12.6.2/Weeks 28, 30, 32, <del>34</del> , 36, 44, and 52      | <p>At Weeks 28, 30, 32, <del>34</del>, 36, 44, and 52, the following procedure will be performed:</p> <ul style="list-style-type: none"> <li>● PBMC collection</li> </ul>   | 1         |
| 12.6.7/Week <del>38</del> <u>36</u> and 52                   | <p>At Weeks <del>38</del> <u>36</u> and 52, the following procedures will be performed:</p> <ul style="list-style-type: none"> <li>● Urine Tests (refer to Table 9.7.8.2.1)</li> <li>● <del>Direct Thrombin test</del></li> <li>● VWF:Ag</li> </ul>   | 1, 3      |
| 12.7/Years 2-5   | <p>Subjects who do not respond to BMN 270 treatment (ie, treatment failure, manifesting as either failure to achieve FVIII activity <math>\geq 5</math> IU/dL by Week 52 or inability to maintain independence from prophylactic FVIII replacement therapy due to joint bleeding episodes, in the judgment of the Investigator) may, at the Investigator's discretion and after discussion with the Medical <u>Monitor</u> or Sponsor-designated <u>Data</u> Monitor, follow an abbreviated visit schedule after Week 52 of the study by attending only the Q12W and End of Year visits during Years 2-5.</p>   | 4         |
| 12.7.3/Years 2-5<br>Every 12 Weeks and<br>End of Year Visits | <p>At the every 12 week and End of Year visits, the following procedures will be performed:</p> <ul style="list-style-type: none"> <li>● <del>Direct Thrombin test</del></li> </ul>   | 3         |



| Section No./Title       | Revision   | Rationale |
|-------------------------|--|-----------|
| 12.8/ETV                | At the Early Termination visit, as many of the following assessments as possible should be done:<br><br>• <del>Direct Thrombin test</del>  | 3         |
| 14.1.1/Interim Analysis | An interim analysis is planned after approximately 20 <del>evaluable-treated</del> HIV-negative subjects have completed the Week 26 visit (or have discontinued study participation prior to Week 26). Data will be reviewed by the DMC, based on the SAP, and a formal recommendation will be made whether to continue the study as designed. | 4         |



**CLINICAL STUDY PROTOCOL**

**Study Title:** A Phase 3 Open-Label, Single-Arm Study To Evaluate The Efficacy and Safety of BMN 270, an Adeno-Associated Virus Vector-Mediated Gene Transfer of Human Factor VIII in Hemophilia A Patients with Residual FVIII Levels  $\leq 1$  IU/dL Receiving Prophylactic FVIII Infusions

**Protocol Number:** 270-301

**Active Investigational Product:** AAV5-hFVIII-SQ

**IND/European Union Drug Regulating Authorities Clinical Trials (EudraCT) Number:** 2017-003215-19  
IND #: 017659

**Indication:** Hemophilia A

**Sponsor:** BioMarin Pharmaceutical Inc.  
105 Digital Drive  
Novato, CA 94949

**Development Phase:** Phase 3

**Sponsor's Responsible Medical Monitor:** PI [redacted] MD, MSc, MBA  
PI [redacted]  
BioMarin Pharmaceutical Inc.  
105 Digital Drive  
Novato, CA 94949

**Duration of Subject Participation:** Approximately 264 weeks

**Dose:** 6E13 vg/kg

**Study Population:** Males aged 18 or older

**Date of Original Protocol:** 14 August 2017

**Date of Amendment 1 (United States Specific):** 2 October 2017

**Date of Amendment 1 (Global):** 25 January 2018

**Date of Amendment 2 (Global):** 28 June 2018

**Date of Amendment 3 (Global):** 24 August 2018

**Date of Amendment 4 (Global):** 9 November 2018

**Date of Amendment 5 (Global):** 10 May 2019 (unreleased)

**Date of Amendment 6 (Global):** 3 April 2020

Property of BioMarin  
**CONFIDENTIAL**

May not be divulged, published, or otherwise disclosed to others without prior written approval from BioMarin.

This study will be conducted according to the principles of Good Clinical Practice as described in the U.S. Code of Federal Regulations and the International Conference on Harmonisation Guidelines, including the archiving of essential documents



---

**CLINICAL STUDY PROTOCOL AMENDMENT SUMMARY****Amendment 6****Date: 3 April 2020**

---

**RATIONALE AND SUMMARY OF CHANGES**

Note that global Amendment 5 to the protocol (dated 10 May 2019) was written but never released to health authorities or implemented at any study site. The primary change in global Amendment 5 was a revision of the interim analysis language to allow for the possibility of a second interim analysis. After the first interim analysis was performed in May 2019, it was determined that the second interim analysis would not be needed and, as such, the change contemplated by the protocol amendment would no longer be needed as it would not lead to a change in either the conduct or analysis of the study and its data. The relevant changes from global Amendment 5, including a description of the possible second interim analysis, have been incorporated into Amendment 6.

A summary of major changes covered by Amendment 6 to the 270-301 protocol is provided below. These changes do not affect sample size, endpoint definition, or statistical methods related to the final efficacy analysis of the study:

1. Language concerning the interim analysis has been modified.

**Rationale:** The number and timing of the interim analyses have been revised to reflect the current revised plan to expedite the development of BioMarin's BMN 270 gene therapy program for the treatment of hemophilia A. Instead of one interim analysis as originally planned, two interim analyses were planned after the first approximately 16 and 20 HIV-negative have completed the Week 26 visit (or have discontinued study participation prior to Week 26), respectively. The first interim analysis was performed as planned in May 2019. Based on the interim results and the totality of the data, the secondary interim analysis was deemed unnecessary. Subject enrollment has completed; the final analysis is planned after all subjects have completed Week 52 visit (or have discontinued study participation prior to Week 52)..

2. PBMC collection has been removed from the Week 30 visit.

**Rationale:** The Week 30 visit has been designated a lab-only or mobile nursing visit, and as such PBMC samples will not be collected.

3. The prohibition on the use of non-corticosteroid systemic immunosuppressive agents following BMN 270 dosing has been removed.

**Rationale:** The intention of the language was to prohibit use of non-steroidal systemic immunosuppressive agents within 30 days before the BMN 270 infusion, in line with the study exclusion criteria. Following dosing with BMN 270, non-steroidal systemic immunosuppressive agents may be used, following a discussion between the Investigator and the Medical Monitor, if corticosteroid use for the treatment of elevated hepatic transaminases has been clinically deemed to be ineffective, not tolerated, and/or contraindicated by the Investigator.

4. Vector shedding and contraception use language has been updated to change the determination of a “clear” result from negative to below the limit of detection.

**Rationale:** The change in language better reflects regulatory guidance documents.

5. Clarifying language has been provided for circumstances where a positive vector shedding sample occurs after 3 consecutive tests below the limit of detection have already been obtained.

**Rationale:** The protocol did not previously specify whether testing should be restarted after a positive result occurs after 3 consecutive results below the limit of detection in a matrix have been obtained. While this situation would be expected to be rare, and usually subjects remain below the limit of detection after having achieved 3 results below the limit of detection in a row, in the instance where a positive test occurs then testing should restart and continue until an additional 3 consecutive results below the limit of detection have been obtained.

The purpose of the testing is to declare vector clearance, and in the instance where a positive test occurs even after 3 tests below the limit of detection, clearance cannot be confirmed without further testing.

6. The requirements around the use of mobile nursing (MN) services to conduct unscheduled visits for assessment of FVIII levels or liver tests (LTs) have been clarified.

**Rationale:** In instances where a subject’s LTs have been elevated, assessment and workup of those elevations may require additional laboratory work (FVIII and LT levels) to be collected at unscheduled visits. At sites where MN services have been approved, these unscheduled laboratory tests may be performed by a MN professional, rather than requiring a site visit.

7. At sites where the use of MN services has been approved, at visits not specifically designated for MN eligibility (ie, visits where the subject is intended to return to the site for assessment) MN services may now be used if the subject is unable to attend the site to complete the study visit during the acceptable window for that visit, upon prior approval by the Medical Monitor and discussion between the Medical Monitor and Investigator.

**Rationale:** If for logistical reasons a subject is unable to return to the site within the designated visit window for a site-required visit, the subject may undergo assessment by a MN professional for that visit with previous approval by the Medical Monitor. Adding this flexibility will allow for at least partial data collection at these visits rather than a completely missed visit, as a way to help continue to monitor subject safety and welfare.

8. In the event that neither an MN visit nor a lab-only visit is possible at a post-infusion visit timepoint, the site should telephone the subject to collect adverse event, concomitant medication, and diary (bleeding events and FVIII usage) information.

**Rationale:** Where circumstances are such that subjects can neither been seen at the site or have access to MN services, sites will be asked to telephone the subject to collect diary data, AE information, and any changes to concomitant medications, so as to enable some degree of continued monitoring of subjects in the event that visits are being missed.

9. Guidance for the monitoring and management of elevated hepatic transaminases has been modified.

**Rationale:** To reflect observations and data gathered from this study and other BMN 270 studies, the threshold for suggested increase in monitoring of hepatic transaminases has been changed from  $\geq 1.5x$  ULN or  $> ULN$  &  $> 2x$  baseline value to  $> ULN$  or  $\geq 1.5x$  baseline value. A similar change has been made to the definition of an event of special interest related to elevated transaminases. Guidance has also been added for investigators to provide counselling and support to study subjects regarding the side effects of corticosteroids. This change should also encourage earlier treatment with corticosteroids, which could help decrease the extent of increases in ALT and better preserve FVIII expression.

10. An optional liver biopsy substudy has been added to the protocol.

**Rationale:** BMN 270 is an AAV5-based gene therapy vector that expresses the SQ form of hFVIII under the control of a liver-selective promoter. It was designed to direct long term FVIII transgene expression within the liver as measured by an increase in circulating levels of hFVIII and produce less frequent episodes of bleeding and the need for exogenous FVIII infusions. Health of the liver after gene transduction has been monitored indirectly by periodic assessments of hepatic enzymes released into the blood stream. Inter-subject variability in post-therapy hFVIII levels has been observed. Neither the reasons for the variations in response to FVIII gene therapy nor the effects on hepatic tissue structure and

function are known. The purpose of this exploratory substudy is to provide a better understanding of the variation in hFVIII levels observed after gene therapy by direct examination of liver tissue for any pathologic alterations within the liver or alterations in hepatocyte structure and to characterize the transduced gene form and distribution.

11. The occurrence of events of Hy's law has been added as an event of special interest (EOSI) for purposes of expedited safety reporting, and additional safety monitoring in the event of a case potentially meeting Hy's law criteria has been added.

**Rationale:** Events potentially meeting the criteria for Hy's law involve combined assessment of elevations in aminotransferases and total bilirubin levels, while the current list of EOSI focuses on elevations in aminotransferases. To date, no events meeting the criteria for Hy's law have been reported in any BMN 270 study. While monitoring for events of Hy's law has been ongoing as part of routine pharmacovigilance in all BMN 270 studies, this change ensures that the occurrence of any events in the future will be reported in an expedited manner. In addition, expanded laboratory monitoring (to include albumin and PT/INR) has been added to the guidelines for evaluating potential Hy's law cases.

12. An optional monthly phone check-in has been added during Years 2-5 for subjects who are returning to the site only every 12 weeks due to poor FVIII response following BMN 270 infusion.

**Rationale:** To ensure timely safety monitoring and promote subject retention, subjects who are not attending the Q4W/Q6W visits during Years 2-5 may receive a scheduled monthly follow-up telephone call from the site to ask about adverse events, concomitant medications, and bleeding events/FVIII replacement usage.

13. The option to assess an adverse event as related/not related to corticosteroids or other systemic immunosuppressive agents has been added.

**Rationale:** AEs associated with corticosteroids or other systemic immunosuppressive agents (if used) are possible and should be noted as such on the eCRF (and for safety monitoring and risk:benefit assessment purposes).

14. Guidance for tapering corticosteroids has been updated.

**Rationale:** The guidance for tapering corticosteroids, including the ALT thresholds for tapering and the duration of the taper, has been changed to reflect data collected in this and other BMN 270 studies, as well as to be consistent with other BMN 270 study protocols.

15. Lamivudine has been removed as a prohibited medication.

**Rationale:** Lamivudine was added as a prohibited medication after an HIV-positive subject in a BMN 270 study developed severe ALT elevations while receiving anti-retroviral therapy

---

that included lamivudine as one of its components (and out of concern that lamivudine might be interacting with BMN 270 to exacerbate ALT elevations). However, after discussion with a liver health advisory board, lamivudine is not viewed as a likely medication that would interact with BMN 270 and, as such, should no longer be listed as a prohibited medication.

16. Guidance concerning how to determine whether a subject has been lost to follow-up has been added.
17. The vector genome schematic has been updated.
18. Risk-benefit language has been updated to reflect more current clinical results.
19. The required timepoints for vector shedding sample collection during Years 2-5 (if required) have been clarified.
20. The identity of the medical monitor has been updated.
21. The costs and compensation language has been updated to clarify which study-related costs will be covered by the Sponsor.
22. Minor changes have been made for purposes of consistency and clarity.

Refer to Section [25](#) for a summary of revisions to Amendment 4 (dated 9 November 2018).

## 2 SYNOPSIS

|   |   |  |
|---|---|--|
| <p><b>NAME OF COMPANY</b><br/>BioMarin Pharmaceutical Inc.<br/>105 Digital Drive<br/>Novato, CA 94949</p> <p><b>NAME OF FINISHED PRODUCT:</b><br/>BMN 270</p> <p><b>NAME OF ACTIVE INGREDIENT:</b><br/>AAV5-hFVIII-SQ</p>   | <p><b>SUMMARY TABLE</b><br/>Referring to Part of the<br/>Dossier:</p> <p>Volume:</p> <p>Page:</p> <p>Reference:</p> | <p><b>FOR NATIONAL<br/>AUTHORITY USE<br/>ONLY:</b></p> |
| <p><b>TITLE OF STUDY:</b><br/>A Phase 3 Open-Label, Single-Arm Study To Evaluate The Efficacy and Safety of BMN 270, an Adeno-Associated Virus Vector-Mediated Gene Transfer of Human Factor VIII in Hemophilia A Patients with Residual FVIII Levels <math>\leq</math> 1 IU/dL Receiving Prophylactic FVIII Infusions</p>  |   |  |
| <p><b>PROTOCOL NUMBER:</b><br/>270-301</p>  |   |  |
| <p><b>STUDY SITES:</b><br/>Approximately 60 sites worldwide.</p>  |   |  |
| <p><b>PHASE OF DEVELOPMENT:</b><br/>Phase 3</p>   |   |  |
| <p><b>STUDY RATIONALE:</b><br/>Hemophilia A (HA) is an X-linked recessive bleeding disorder that affects approximately 1 in 5,000 males. It is caused by deficiency in the activity of coagulation factor VIII (FVIII), an essential cofactor in the intrinsic coagulation pathway. This disorder can be either inherited, due to a genetic aberrancy, or an acquired immunologic process, leading to insufficient quantities of FVIII or a dysfunctional FVIII, but all are characterized by a defective coagulation process. The clinical phenotype of HA patients generally correlates tightly with the level of residual expression. Severe HA is classified as FVIII activity less than 1% of wild-type (&lt; 1 IU/dL), moderate disease comprises 1-5% of wild-type activity and the mild form is 5-40% activity. The clinical manifestations of severe HA are frequent spontaneous bleeding episodes, predominantly in joints and soft tissues, with a substantially increased risk of death from hemorrhage when the brain is involved. Subjects with moderate disease can exhibit manifestations similar to those seen in patients with severe HA, resulting in a comparable bleeding phenotype. Treatment of severe HA presently consists of intravenous injection of plasma-derived or recombinant human FVIII protein (rhFVIII) concentrates, both as prophylaxis 2-3 times per week, and at the time of a bleed, to prevent or control bleeding episodes, respectively. The half-life for FVIII (12 to 18 hours for most approved products) necessitates frequent infusions, and although a major advance in the treatment of HA, it remains common for severe HA patients to continue to have multiple bleeding events on prophylactic therapy (median ABR of 1-4 with prophylaxis treatment in a recently published retrospective observational study (Berntorp, 2017) and between 1-2 in 6 prospective FVIII interventional studies) and on-demand-only therapy (median ABR of 4.5-18 in a recently published retrospective study (Berntorp, 2017) and between 20-60 in 6 prospective FVIII interventional studies). The consequence of multiple bleeding events is the</p> |   |  |



| <b>NAME OF COMPANY</b><br>BioMarin Pharmaceutical Inc.<br>105 Digital Drive<br>Novato, CA 94949<br><br><b>NAME OF FINISHED PRODUCT:</b><br>BMN 270<br><br><b>NAME OF ACTIVE INGREDIENT:</b><br>AAV5-hFVIII-SQ   | <b>SUMMARY TABLE</b><br>Referring to Part of the<br>Dossier:<br><br>Volume:<br><br>Page:<br><br>Reference: | <b>FOR NATIONAL<br/>                     AUTHORITY USE<br/>                     ONLY:</b> |
|---|--|---|
| <p>development of debilitating multiple-joint arthropathy and substantially increased risk of death. Chemical modification (eg, direct conjugation of polyethylene glycol (PEG) polymers) and bioengineering of FVIII (eg, FVIII-Fc fusion proteins) improve half-life by approximately 50%, and thus, show promise in reduced dosing and maintaining activity levels above a 1% trough for a greater proportion of the dosing interval. However, patients with severe HA who are treated with extended half-life FVIII remain dependent on multiple infusions to maintain critical levels of FVIII activity. There is therefore a strong unmet need for a fully preventive treatment of HA to give patients a FVIII level compatible with a normal and hemorrhage-free life.</p> <p>Gene therapy offers the potential of disease-modifying therapy by continuous endogenous production of active FVIII following a single intravenous infusion of a vector encoding the appropriate gene sequence for long-term episomal expression. Hemophilia A is well-suited for a gene replacement approach because clinical manifestations are attributable to the lack of a single gene product (FVIII) that circulates in minute amounts (200 ng/ml) in the plasma. Tightly regulated control of gene expression is not essential, and even modest increases in the level of FVIII (any increase of the plasma level by 2 ng/ml induces an increase in activity of 1%) can ameliorate the severe form of hemophilia A. Thus, relatively small changes in endogenous FVIII activity can result in clinically relevant improvements in disease phenotype. Finally, the circulating FVIII response to gene transduction can be assessed using validated quantitative rather than qualitative endpoints that are easily assayed using established laboratory techniques.</p> <p>Several different gene transfer strategies for FVIII replacement have been evaluated, but adeno-associated viral (AAV) vectors show the greatest promise. They have an excellent and well-defined safety profile, and can direct long-term transgene expression with tropism and promoter specificity for specific tissues, such as the liver (for serotypes 2, 5 and 8 among others). Indeed, an ongoing gene therapy clinical trial for a related disorder, hemophilia B, has established that stable (median follow-up of 3.2 years) expression of human factor IX (hFIX) at levels that are sufficient for conversion of their bleeding phenotype from severe to moderate or mild is achievable following a single peripheral vein infusion of AAV8-hFIX vector. Several participants in this trial have been able to discontinue factor prophylaxis without suffering spontaneous hemorrhages, even when they undertook activities that previously resulted in bleeding. Thus, gene therapy treatment has resulted in a substantial improvement in their quality of life (Nathwani, 2014).</p> <p>BMN 270 is an AAV5-based gene therapy vector that expresses the SQ form of hFVIII under the control of a hybrid human liver-specific promoter (Figure 1).</p> |  |   |



|   |   |  |
|---|---|--|
| <p><b>NAME OF COMPANY</b><br/>BioMarin Pharmaceutical Inc.<br/>105 Digital Drive<br/>Novato, CA 94949</p> <p><b>NAME OF FINISHED PRODUCT:</b><br/>BMN 270</p> <p><b>NAME OF ACTIVE INGREDIENT:</b><br/>AAV5-hFVIII-SQ</p> | <p><b>SUMMARY TABLE</b><br/>Referring to Part of the Dossier:</p> <p>Volume:</p> <p>Page:</p> <p>Reference:</p> | <p><b>FOR NATIONAL AUTHORITY USE ONLY:</b></p> |
|---|---|--|

**Figure 1: hFVIII-SQ Vector Genome and Encoded Protein**

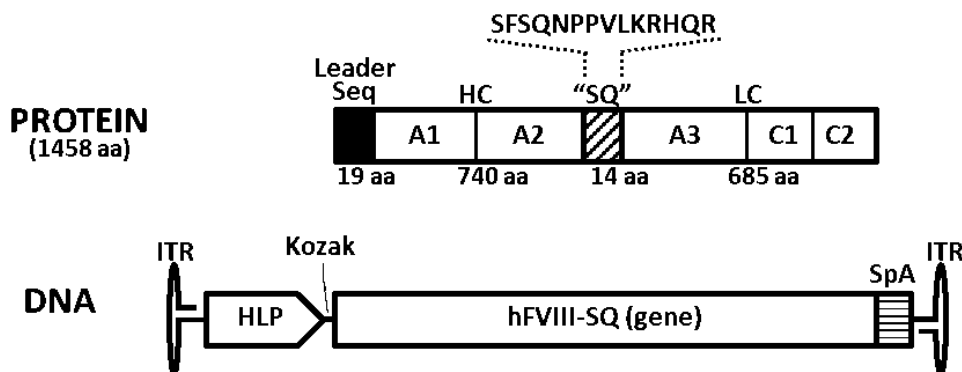

Legend –Note that schematic is not to scale; aa = amino acids; ITR = inverted terminal repeat; HLP = human liver promoter; Kozak = Kozak consensus sequence (GCCACC); SpA = Synthetic poly(A) signal

BMN 270 will be delivered by a single intravenous dose and is designed to achieve stable, potentially life-long expression of active hFVIII in the plasma, synthesized from vector-transduced liver tissue.

BMN 270 is being evaluated in clinical study 270-201, an ongoing first-in-human, phase 1/2 dose escalation study in subjects with severe HA designed to assess the safety and efficacy of BMN 270 at various dose levels (6E12 vg/kg, 2E13 vg/kg, 4E13 vg/kg, 6E13 vg/kg). Specifically, 270-201 explores the relationship of vector dose to the augmentation of residual FVIII activity and whether these levels are sufficient to alter the clinical phenotype. Preliminary results from 270-201 have demonstrated that following gene transfer, FVIII activity above 15% (15 IU/dL) and, in many cases, within the normal range for FVIII, is achievable with a dose of 4-6E13 vg/kg with an acceptable safety profile (Pasi, 2017).

The current study is a Phase 3, single-arm, open-label study designed to assess whether, in an expanded sample, BMN 270 can safely alter the clinical phenotype of hemophilia A patients with residual FVIII activity  $\leq$  1 IU/dL.



| <b>NAME OF COMPANY</b><br>BioMarin Pharmaceutical Inc.<br>105 Digital Drive<br>Novato, CA 94949<br><br><b>NAME OF FINISHED PRODUCT:</b><br>BMN 270<br><br><b>NAME OF ACTIVE INGREDIENT:</b><br>AAV5-hFVIII-SQ   | <b>SUMMARY TABLE</b><br>Referring to Part of the<br>Dossier:<br><br>Volume:<br><br>Page:<br><br>Reference: | <b>FOR NATIONAL<br/>           AUTHORITY USE<br/>           ONLY:</b> |
|---|--|---|
| <p><b>OBJECTIVES:</b></p> <p>The primary efficacy objective of the study is to:</p> <ul style="list-style-type: none"> <li>Assess the efficacy of BMN 270 defined as FVIII activity, as measured by chromogenic substrate assay, during Weeks 49-52 following intravenous infusion of BMN 270</li> </ul> <p>The secondary efficacy objectives of the study are to:</p> <ul style="list-style-type: none"> <li>Assess the impact of BMN 270 on usage of exogenous FVIII replacement therapy from Week 5 to Week 52</li> <li>Assess the impact of BMN 270 on the number of bleeding episodes requiring exogenous FVIII replacement therapy from Week 5 to Week 52</li> </ul> <p>The tertiary efficacy objective of the study is to:</p> <ul style="list-style-type: none"> <li>Assess the impact of BMN 270 on patient-reported outcomes (PROs) at Week 52 of the study compared to baseline</li> </ul> <p>The safety objectives of the study are to:</p> <ul style="list-style-type: none"> <li>Evaluate the safety of BMN 270 during the first 52 weeks following intravenous infusion</li> <li>Assess the long-term safety of BMN 270</li> </ul> <p>The exploratory objectives of the liver biopsy substudy are:</p> <ul style="list-style-type: none"> <li>To examine the histopathology of the liver following BMN 270 therapy, including assessing for possible safety findings (eg, fibrosis, fatty liver disease, lymphocytic invasion)</li> <li>To quantify FVIII DNA, RNA, and protein expression within hepatocytes</li> <li>To determine which forms of rAAV vector DNA are present at the time of biopsy.</li> <li>To determine the transduction pattern of BMN 270 in humans (ie, peri-portal hepatocytes, central vein hepatocytes)</li> </ul> |  |   |
| <p><b>STUDY DESIGN AND PLAN:</b></p> <p>This is a Phase 3, single-arm, open-label study in hemophilia A patients with residual FVIII levels <math>\leq 1</math> IU/dL treated continuously with prophylactic exogenous FVIII for a minimum of one year prior to enrollment. Subjects will be enrolled at approximately 60 sites worldwide. Subjects must have high-quality, well-documented historical data available concerning previous bleeding episodes and exogenous FVIII usage over the previous 12 months in order to be eligible to enroll in the study.</p>   |  |   |

|   |   |  |
|---|---|--|
| <p><b>NAME OF COMPANY</b><br/>BioMarin Pharmaceutical Inc.<br/>105 Digital Drive<br/>Novato, CA 94949</p> <p><b>NAME OF FINISHED PRODUCT:</b><br/>BMN 270</p> <p><b>NAME OF ACTIVE INGREDIENT:</b><br/>AAV5-hFVIII-SQ</p> | <p><b>SUMMARY TABLE</b><br/>Referring to Part of the Dossier:</p> <p>Volume:</p> <p>Page:</p> <p>Reference:</p> | <p><b>FOR NATIONAL AUTHORITY USE ONLY:</b></p> |
|---|---|--|

Approximately 130 adult subjects with severe HA will receive a 6E13 vg/kg dose of BMN 270 as a single intravenous infusion. Approximately 20 subjects will enroll in the study with at least 12 months of well-documented high-quality historical data concerning previous bleeding episodes and exogenous FVIII usage, while approximately 110 subjects will enroll in the study after having completed approximately 6 months' participation in the BioMarin-sponsored non-interventional study 270-902, in which bleeding and FVIII use data prior to gene therapy will be prospectively collected.

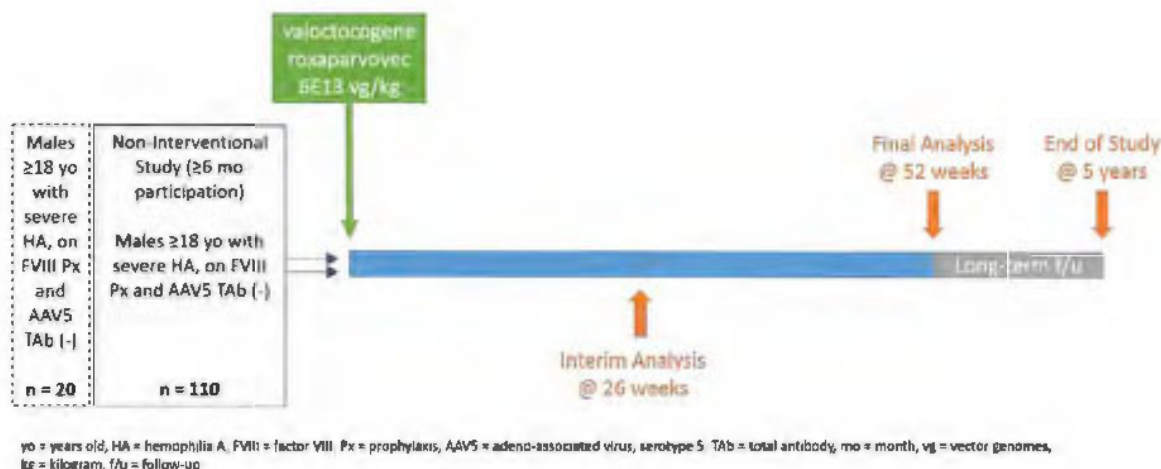

In order to minimize bias in the ongoing study and to assure safe and ethical conduct of the clinical trial, an independent Data Monitoring Committee (DMC), consisting of experts in clinical trials, statistics, and hemophilia, has been convened. The DMC will have sole access during the trial to amalgamated FVIII activity levels, FVIII usage, and bleeding data and review available safety and efficacy (eg, FVIII activity) data during the study on an ongoing basis; they may determine, based on emerging data and the risk/benefit profile, that further enrollment at 6E13 vg/kg should be discontinued in favor of a different dose of BMN 270, not to exceed 6E13 vg/kg. If the DMC recommends a dosing modification, then additional subjects may be enrolled, up to a total of approximately 130 subjects, at the new BMN 270 dose level (regardless of the number of subjects previously enrolled at 6E13 vg/kg).



| <b>NAME OF COMPANY</b><br>BioMarin Pharmaceutical Inc.<br>105 Digital Drive<br>Novato, CA 94949<br><br><b>NAME OF FINISHED PRODUCT:</b><br>BMN 270<br><br><b>NAME OF ACTIVE INGREDIENT:</b><br>AAV5-hFVIII-SQ   | <b>SUMMARY TABLE</b><br>Referring to Part of the<br>Dossier:<br><br>Volume:<br><br>Page:<br><br>Reference: | <b>FOR NATIONAL<br/>                     AUTHORITY USE<br/>                     ONLY:</b> |
|---|--|---|
| <p>Two interim analyses were planned, after the first approximately 16 and 20 treated HIV-negative subjects, respectively, completed the Week 26 visit (or have discontinued study participation prior to Week 26). The first interim analysis was performed as planned in May 2019. Based on the interim results and the totality of the data, the secondary interim analysis was deemed unnecessary. The DMC reviewed interim analysis results to assess the efficacy and safety profiles, whether the pre-specified criteria of statistical significance has been achieved, and the risk/benefit ratio of the interventions in the BMN 270 studies based on the totality of the data.</p> <p>The final analysis for the study will be performed after all subjects have been followed for 52 weeks post-BMN 270 infusion. After the final analysis, safety and efficacy will then continue to be assessed long-term in all subjects for a total of approximately 5 years.</p> <p>To avoid breakthrough bleeding, subjects will only discontinue exogenous prophylactic FVIII replacement therapy 4 weeks following infusion of BMN 270. Four weeks represents the time by which endogenous production of FVIII following gene transfer is expected to be efficacious, based on earlier results.</p> <p>In subjects who experience recurring bleeding episodes, the Investigator and Medical Monitor will discuss whether to resume prior FVIII prophylaxis.</p> <p>Subjects who do not respond to BMN 270 treatment (ie, treatment failure, manifesting as either failure to achieve FVIII activity <math>\geq 5</math> IU/dL by Week 52 or inability to maintain independence from prophylactic FVIII replacement therapy due to joint bleeding episodes, in the judgment of the Investigator) may, at the Investigator’s discretion and after discussion with the Medical Monitor or Sponsor-designated Data Monitor, follow an abbreviated visit schedule after Week 52 of the study by attending only the Q12W and End of Year visits during Years 2-5. Subjects who are not attending the Q4W/Q6W visits during Years 2-5 may receive a scheduled monthly follow-up telephone call from the site to ask about adverse events, concomitant medications, and bleeding events/FVIII replacement usage.</p> <p>There will be an ongoing review of individual subject safety by the Medical Monitor, and both safety and efficacy data by the DMC. Therapeutic oral corticosteroids or other systemic immunosuppressive agents may be initiated when a subject’s ALT values are elevated, and subsequent dosage adjustments made, after consultation between the Investigator and the Medical Monitor.</p> <p>Any safety signal may trigger a review of the data and possible additional immunogenicity studies or other diagnostics deemed necessary that include an assessment of cellular immune responses using collected peripheral blood mononuclear cells (PBMCs).</p> <p>An optional liver biopsy will be performed (in subjects who consent to do so) during Year 1 post-infusion, at or around Week 52, and/or during Years 2-5 following BMN 270 infusion. Subjects who consent to the liver biopsy will have additional assessments, including a liver</p> |  |   |

|   |  |   |
|---|--|---|
| <b>NAME OF COMPANY</b><br>BioMarin Pharmaceutical Inc.<br>105 Digital Drive<br>Novato, CA 94949<br><br><b>NAME OF FINISHED PRODUCT:</b><br>BMN 270<br><br><b>NAME OF ACTIVE INGREDIENT:</b><br>AAV5-hFVIII-SQ   | <b>SUMMARY TABLE</b><br>Referring to Part of the<br>Dossier:<br><br>Volume:<br><br>Page:<br><br>Reference: | <b>FOR NATIONAL<br/>         AUTHORITY USE<br/>         ONLY:</b> |
| ultrasound and FibroScan, and will receive prophylactic FVIII prior to the procedure, as indicated in the judgment of the Investigator, to minimize the risk of bleeding.   |  |   |
| <b>NUMBER OF SUBJECTS PLANNED:</b><br>Approximately 130 subjects may enroll into the study.   |  |   |
| <b>DIAGNOSIS AND ALL CRITERIA FOR INCLUSION AND EXCLUSION:</b><br>Patients are eligible to be included in the study only if all of the following criteria apply: <ol style="list-style-type: none"> <li>1. Males <math>\geq</math> 18 years of age with hemophilia A and residual FVIII levels <math>\leq</math> 1 IU/dL as evidenced by medical history, at the time of signing the informed consent.</li> <li>2. Must have been on prophylactic FVIII replacement therapy for at least 12 months prior to study entry. High-quality, well-documented historical data concerning bleeding episodes and FVIII usage over the previous 12 months must be available.</li> <li>3. Treated/exposed to FVIII concentrates or cryoprecipitate for a minimum of 150 exposure days (EDs).</li> <li>4. Willing and able to provide written, signed informed consent after the nature of the study has been explained and prior to any study-related procedures.</li> <li>5. No previous documented history of a detectable FVIII inhibitor, and results from a Bethesda assay or Bethesda assay with Nijmegen modification of less than 0.6 Bethesda Units (BU) (or less than 1.0 BU for laboratories with a historical lower sensitivity cutoff for inhibitor detection of 1.0 BU) on 2 consecutive occasions at least one week apart within the past 12 months (at least one of which should be tested at the central laboratory).</li> <li>6. Sexually active participants must agree to use an acceptable method of effective contraception, either double-barrier contraception (ie, condom + diaphragm; or condom or diaphragm + spermicidal gel or foam) or their female partner either using hormonal contraceptives or having an intrauterine device. Participants must agree to contraception use for at least 12 weeks post-infusion; after 12 weeks, subjects may stop contraception use only if they have had 3 consecutive semen samples with viral vector DNA below the limit of detection.</li> <li>7. Willing to abstain from alcohol consumption for at least the first 52 weeks following BMN 270 infusion.</li> </ol> Patients are excluded from the study if any of the following criteria apply: <ol style="list-style-type: none"> <li>1. Detectable pre-existing antibodies to the AAV5 capsid.</li> </ol> |  |   |

| <b>NAME OF COMPANY</b><br>BioMarin Pharmaceutical Inc.<br>105 Digital Drive<br>Novato, CA 94949<br><br><b>NAME OF FINISHED PRODUCT:</b><br>BMN 270<br><br><b>NAME OF ACTIVE INGREDIENT:</b><br>AAV5-hFVIII-SQ  | <b>SUMMARY TABLE</b><br>Referring to Part of the<br>Dossier:<br><br>Volume:<br><br>Page:<br><br>Reference: | <b>FOR NATIONAL<br/>           AUTHORITY USE<br/>           ONLY:</b> |
|--|--|---|
| <ol style="list-style-type: none"> <li>2. Any evidence of active infection or any immunosuppressive disorder, including HIV infection.</li> <li>3. Significant liver dysfunction with any of the following abnormal laboratory results:               <ul style="list-style-type: none"> <li>• ALT (alanine aminotransferase) &gt; 1.25x ULN;</li> <li>• AST (aspartate aminotransferase) &gt; 1.25x ULN;</li> <li>• GGT (gamma-glutamyltransferase) &gt; 1.25x ULN;</li> <li>• Total bilirubin &gt; 1.25x ULN;</li> <li>• Alkaline phosphatase &gt; 1.25x ULN; or</li> <li>• INR (international normalized ratio) ≥ 1.4.</li> </ul> <p>Subjects whose liver laboratory assessments fall outside of these ranges may undergo repeat testing of the entire liver test panel within the same Screening window and, if eligibility criteria are met on retest, may be enrolled after confirmation by the Medical Monitor.</p> </li> <li>4. Prior liver biopsy showing significant fibrosis of 3 or 4 as rated on a scale of 0-4 on the Batts-Ludwig (<a href="#">Batts, 1995</a>) or METAVIR (<a href="#">Bedossa, 1996</a>) scoring systems, or an equivalent grade of fibrosis if an alternative scale is used.</li> <li>5. Evidence of any bleeding disorder not related to hemophilia A.</li> <li>6. Platelet count of &lt; 100 x 10<sup>9</sup>/L.</li> <li>7. Creatinine ≥ 1.5 mg/dL.</li> <li>8. Liver cirrhosis of any etiology as assessed by liver ultrasound.</li> <li>9. Chronic or active hepatitis B as evidenced by positive serology testing (hepatitis B surface antigen [HBsAg], hepatitis B surface antibody [HBsAb], and hepatitis B core antibody [HBcAb]) and confirmatory HBV DNA testing. Refer to the Centers for Disease Control (CDC) table for the interpretation of serological test results in the Laboratory Manual.</li> <li>10. Active Hepatitis C as evidenced by detectable HCV RNA or currently on antiviral therapy.</li> <li>11. Active malignancy, except non-melanoma skin cancer.</li> <li>12. History of hepatic malignancy.</li> </ol> |  |   |



| <b>NAME OF COMPANY</b><br>BioMarin Pharmaceutical Inc.<br>105 Digital Drive<br>Novato, CA 94949<br><br><b>NAME OF FINISHED PRODUCT:</b><br>BMN 270<br><br><b>NAME OF ACTIVE INGREDIENT:</b><br>AAV5-hFVIII-SQ  | <b>SUMMARY TABLE</b><br>Referring to Part of the<br>Dossier:<br><br>Volume:<br><br>Page:<br><br>Reference: | <b>FOR NATIONAL<br/>                     AUTHORITY USE<br/>                     ONLY:</b> |
|--|--|---|
| <ol style="list-style-type: none"> <li>13. History of arterial or venous thromboembolic events (eg, deep vein thrombosis, non-hemorrhagic stroke, pulmonary embolism, myocardial infarction, arterial embolus), with the exception of catheter-associated thrombosis for which anti-thrombotic treatment is not currently ongoing.</li> <li>14. Known inherited or acquired thrombophilia, including conditions associated with increased thromboembolic risk, such as atrial fibrillation.</li> <li>15. Treatment with any investigational product within 30 days or 5 half-lives of the investigational product prior to the screening period. For subjects who have received a prior investigational product, all ongoing adverse events (AEs) experienced while receiving that investigational product must have resolved prior to screening for this study.</li> <li>16. Any condition that, in the opinion of the Investigator or Sponsor would prevent the patient from fully complying with the requirements of the study (including possible corticosteroid treatment outlined in the protocol) and/or would impact or interfere with evaluation and interpretation of subject safety or efficacy result.</li> <li>17. Prior treatment with any vector or gene transfer agent.</li> <li>18. Major surgery planned in the 52-week period following the infusion with BMN 270.</li> <li>19. Use of systemic immunosuppressive agents, not including corticosteroids, or live vaccines within 30 days before the BMN 270 infusion.</li> <li>20. Concurrent enrollment in another clinical study, unless it is an observational (non-interventional) clinical study that does not interfere with the requirements of the current protocol or have the potential to impact the evaluation of efficacy and safety of BMN 270 and with prior consultation with the Medical Monitor.</li> <li>21. Known allergy or hypersensitivity to BMN 270 investigational product formulation.</li> <li>22. Unwilling to receive blood or blood products for treatment of an adverse event and/or a bleeding episode.</li> </ol> |  |   |
| <p><u>Optional Liver Biopsy Inclusion and Exclusion Criteria</u><br/>                     Individuals eligible for the optional liver biopsy must meet the following inclusion criterion:</p> <ol style="list-style-type: none"> <li>1. Able to sign informed consent and comply with requirements for the optional liver biopsy</li> </ol>  |  |   |



| <b>NAME OF COMPANY</b><br>BioMarin Pharmaceutical Inc.<br>105 Digital Drive<br>Novato, CA 94949<br><br><b>NAME OF FINISHED PRODUCT:</b><br>BMN 270<br><br><b>NAME OF ACTIVE INGREDIENT:</b><br>AAV5-hFVIII-SQ  | <b>SUMMARY TABLE</b><br>Referring to Part of the<br>Dossier:<br><br>Volume:<br><br>Page:<br><br>Reference: | <b>FOR NATIONAL<br/>           AUTHORITY USE<br/>           ONLY:</b> |
|--|--|---|
| <p>2. Documentation of FVIII activity level <math>\geq 50</math> IU/dL (or higher, depending on local guidelines and/or Investigator discretion) within 24 hours prior to the liver biopsy being performed (FVIII activity levels should be assessed at the local laboratory). Subjects may be treated with additional exogenous FVIII replacement products in order to increase their FVIII activity to an appropriate level, under the supervision/instruction of the Investigator.</p> <p>Individuals who meet any of the following exclusion criteria will not be eligible for the optional liver biopsy:</p> <ol style="list-style-type: none"> <li>1. Any condition that, in the opinion of the Investigator or a hepatologist or radiologist, would make liver biopsy contraindicated. This includes (but is not limited to): abnormalities detected on liver ultrasound performed within 28 days of procedure or prior liver ultrasound result within 90 days that would preclude safe performance of the biopsy.</li> </ol>   |  |   |
| <p><b>INVESTIGATIONAL PRODUCT(S), DOSE, ROUTE AND REGIMEN:</b><br/>           Each subject will receive a single intravenous infusion of BMN 270 at 6E13 vg/kg. The volume of infusion will depend on the subject's weight.</p>  |  |   |
| <p><b>REFERENCE THERAPY(IES), DOSE, ROUTE AND REGIMEN:</b><br/>           No reference therapy will be evaluated in this study.</p>  |  |   |
| <p><b>DURATION OF TREATMENT:</b><br/>           BMN 270 is given as a single dose by intravenous infusion.</p>   |  |   |
| <p><b>CRITERIA FOR EVALUATION:</b></p> <p><u>Efficacy:</u></p> <p>Primary efficacy endpoint:</p> <ul style="list-style-type: none"> <li>• Change of the hFVIII activity, as measured by chromogenic substrate assay, during Weeks 49-52 post-BMN 270 infusion from baseline. Each subject's hFVIII activity during Weeks 49-52 is defined as the median of the values obtained during this 4-week window. Values for hFVIII activity will be excluded if obtained within 72 hours since the last infusion of exogenous FVIII protein concentrates.</li> </ul> <p>Secondary efficacy endpoints:</p> <ul style="list-style-type: none"> <li>• Change in the annualized utilization (IU/kg) of exogenous FVIII replacement therapy during Week 5 to Week 52 post-BMN 270 infusion from the baseline utilization of exogenous FVIII replacement therapy.</li> <li>• Change in the annualized number of bleeding episodes requiring exogenous FVIII replacement treatment (annualized bleeding rate, ABR) during Week 5 to Week 52 of the study post-BMN 270 infusion from the baseline ABR.</li> </ul> |  |   |



|  |   |  |
|--|---|--|
| <p><b>NAME OF COMPANY</b><br/>BioMarin Pharmaceutical Inc.<br/>105 Digital Drive<br/>Novato, CA 94949</p> <p><b>NAME OF FINISHED PRODUCT:</b><br/>BMN 270</p> <p><b>NAME OF ACTIVE INGREDIENT:</b><br/>AAV5-hFVIII-SQ</p>  | <p><b>SUMMARY TABLE</b><br/>Referring to Part of the<br/>Dossier:</p> <p>Volume:</p> <p>Page:</p> <p>Reference:</p> | <p><b>FOR NATIONAL<br/>AUTHORITY USE<br/>ONLY:</b></p> |
| <p>Tertiary efficacy endpoints:</p> <ul style="list-style-type: none"> <li>• Change from baseline in the total score of HAEMO-QoL-A at Week 52 of the study post-BMN 270 infusion.</li> <li>• Change from baseline in the EQ-5D-5L score at Week 52 of the study post-BMN 270 infusion.</li> <li>• Change from baseline in the Haemophilia Activities List (HAL) score at Week 52 of the study post-BMN 270 infusion.</li> <li>• Change from baseline in the Work Productivity and Activity Impairment plus Classroom Impairment Questions: Hemophilia Specific (WPAI+CIQ:HS) score at Week 52 of the study post-BMN 270 infusion.</li> <li>• Change from baseline in Patient Reported Outcomes, Burdens, and Experiences (PROBE) score at Week 52 of the study post-BMN 270 infusion.</li> </ul> <p><u>Safety:</u></p> <p>The following safety outcome measurements will be assessed:</p> <ul style="list-style-type: none"> <li>• Incidence of adverse events (AEs) and serious AEs (SAEs)</li> <li>• Change in clinical laboratory tests (serum chemistry and hematology)</li> <li>• Change in vital signs</li> <li>• Change in physical examination</li> <li>• Vector shedding (blood, urine, semen, stool, saliva)</li> <li>• Liver tests (LTs, including ALT, AST, GGT, direct and total bilirubin, lactate dehydrogenase [LDH], and alkaline phosphatase)</li> <li>• Immune response to FVIII transgene product and AAV5 capsid proteins</li> </ul> <p>Each subject will have comprehensive surveillance monitoring of LTs (once per week for Weeks 1-36, and then once every 2 weeks from Weeks 37-52) during Year 1. LTs will be monitored every four weeks during Year 2 and then every 6 weeks during Years 3-5 post-dose in the safety extension; the frequency and duration of LT testing may be changed based on discussion between the Medical Monitor and the Investigator, review of subject data, and/or by independent DMC feedback.</p> <p>There will be a detailed assessment of cellular and humoral responses to AAV5 capsid and FVIII protein.</p> |   |  |



| <b>NAME OF COMPANY</b><br>BioMarin Pharmaceutical Inc.<br>105 Digital Drive<br>Novato, CA 94949<br><br><b>NAME OF FINISHED PRODUCT:</b><br>BMN 270<br><br><b>NAME OF ACTIVE INGREDIENT:</b><br>AAV5-hFVIII-SQ  | <b>SUMMARY TABLE</b><br>Referring to Part of the<br>Dossier:<br><br>Volume:<br><br>Page:<br><br>Reference: | <b>FOR NATIONAL<br/>           AUTHORITY USE<br/>           ONLY:</b> |
|--|--|---|
| <p><u>Pharmacodynamics:</u></p> <p>The FVIII protein concentration and activity level as measured by a validated immunoassay and a validated FVIII activity assay, respectively, will be used for plasma profiles; FVIII protein and activity will be used to determine PD parameters.</p>   |  |   |
| <p><b>STATISTICAL METHODS:</b></p> <p><u>Sample Size</u></p> <p>Approximately one hundred and thirty (130) subjects may be dosed in the study. The sample size for this study is based on clinical and statistical considerations in order to provide sufficient data to assess both safety and efficacy of BMN 270.</p> <p>For the primary endpoint, a sample size of 130 will provide at least 95% power to demonstrate that the change in hFVIII activity during Weeks 49-52 from baseline is greater than 0, assuming an effect size of 0.6, using a one-sample t-test with a 2-sided significance level of 0.05.</p> <p>For the secondary endpoints, the analyses will be performed utilizing exogenous FVIII use and bleeding episode data from the 110 subjects whose baseline data will be prospectively collected for approximately 6 months in the non-interventional study 270-902, prior to their enrollment in 270-301. An analytic sample size of 110 will provide at least 95% power to demonstrate that the change in the annualized utilization (IU/kg) of exogenous FVIII replacement therapy during Week 5 to Week 52 post-BMN 270 infusion from baseline is less than 0, assuming an effect size of 0.6, using a one-sample t-test with a 2-sided significance level of 0.05.</p> <p>An analytic sample size of 110 will also have at least 95% power to demonstrate that the change in the annualized number of bleeding episodes requiring exogenous FVIII replacement treatment (ABR) during Week 5 to Week 52 of the study post-BMN 270 infusion from the baseline ABR is less than 3.5 (non-inferiority margin), assuming the pre- and post-BMN 270 infusion population mean ABRs are 3.5 and 1 respectively, using a one-sample t-test with a 2-sided significance level of 0.05. Under the same assumptions, a sample size of 110 will have approximately 90% power to demonstrate that the change is less than 0, i.e. superiority of BMN 270 against FVIII prophylaxis.</p> <p>Overall, the planned sample size will have greater than 80% power for testing the primary and secondary efficacy endpoints hierarchically with a 2-sided significance level of 0.05.</p> <p><u>Analysis Population</u></p> <p>The intention-to-treat (ITT) population is defined as all subjects who receive BMN 270 infusion, and the modified intention-to-treat (mITT) population is defined as subjects who receive BMN 270 infusion and are HIV-negative. The mITT population will be used for the primary efficacy</p> |  |   |

| <b>NAME OF COMPANY</b><br>BioMarin Pharmaceutical Inc.<br>105 Digital Drive<br>Novato, CA 94949<br><br><b>NAME OF FINISHED PRODUCT:</b><br>BMN 270<br><br><b>NAME OF ACTIVE INGREDIENT:</b><br>AAV5-hFVIII-SQ   | <b>SUMMARY TABLE</b><br>Referring to Part of the<br>Dossier:<br><br>Volume:<br><br>Page:<br><br>Reference: | <b>FOR NATIONAL<br/>           AUTHORITY USE<br/>           ONLY:</b> |
|---|--|---|
| <p>analysis, and the ITT population will be used for the supportive efficacy analysis. The ITT population will also be used for the safety analysis.</p> <p><u>Analysis</u></p> <p>For the primary efficacy endpoint at Week 52 (ie, the change in the hFVIII activity during Weeks 49-52 post-BMN 270 infusion from baseline, as measured by chromogenic substrate assay), a one-sample t-test will be used to test the null hypothesis that the change is 0 or less against the alternative hypothesis that the change is greater than 0. Descriptive summaries of the proportions of subjects whose FVIII activity during Weeks 49-52 is greater than or equal to select thresholds, such as 15, 25 and 30 IU/dL, and the confidence intervals of the proportions will also be provided.</p> <p>For the secondary endpoints, the analyses will be performed on 110 subjects in the mITT population whose baseline data will be prospectively collected for approximately 6 months in the non-interventional study 270-902 prior to their enrollment in 270-301.</p> <p>For the first secondary efficacy endpoint at Week 52 (ie, the change in the annualized utilization (IU/kg) of exogenous FVIII replacement therapy during Weeks 5-52 post-BMN 270 infusion from baseline), a one-sample t-test will be performed to test the null hypothesis that the change is 0 or greater against the alternative hypothesis that the change is less than 0.</p> <p>For the second secondary efficacy endpoint at Week 52 (ie, the change in the annualized number of bleeding episodes requiring exogenous FVIII replacement treatment during Weeks 5-52 post-BMN 270 infusion from baseline), a one-sample t-test will be performed to test for non-inferiority of BMN 270 against FVIII prophylaxis (ie, the baseline ABR calculated using subjects' data collected in 270-902) using a margin of 3.5, ie, to test the null hypothesis that the change is 3.5 or greater against the alternative hypothesis that the change is less than 3.5. If non-inferiority is demonstrated, the test for superiority of BMN 270 against FVIII prophylaxis will be performed.</p> <p>The primary efficacy endpoint and secondary efficacy endpoints will be tested hierarchically according to the order described above.</p> <p>Two interim analyses were planned, after approximately 16 and 20 treated HIV-negative subjects, respectively, completed the Week 26 visit (or have discontinued study participation prior to Week 26). The first interim analysis was performed as planned in May 2019. Based on the interim results and the totality of the data, the secondary interim analysis was deemed unnecessary. The DMC reviewed the interim analysis results to assess the efficacy and safety profiles, whether the pre-specified criteria of statistical significance has been achieved, and the risk/benefit ratio of the interventions in the BMN 270 studies based on the totality of the data. The primary efficacy endpoint for the interim analyses involves hFVIII activity, as measured by chromogenic substrate assay, achieved post-BMN 270 infusion, as detailed in the statistical analysis plan (SAP).</p> |  |   |



| <b>NAME OF COMPANY</b><br>BioMarin Pharmaceutical Inc.<br>105 Digital Drive<br>Novato, CA 94949<br><br><b>NAME OF FINISHED PRODUCT:</b><br>BMN 270<br><br><b>NAME OF ACTIVE INGREDIENT:</b><br>AAV5-hFVIII-SQ  | <b>SUMMARY TABLE</b><br>Referring to Part of the<br>Dossier:<br><br>Volume:<br><br>Page:<br><br>Reference: | <b>FOR NATIONAL<br/>                     AUTHORITY USE<br/>                     ONLY:</b> |
|--|--|---|
| <p>The fallback procedure will be used to adjust for multiplicity of the two interim analyses at Week 26 and the final analysis at Week 52 (regardless of the interim analyses results, the study is planned to continue upon the DMC’s recommendation, and the final analysis will be performed at Week 52). At the final analysis at Week 52, the secondary efficacy endpoints will be tested hierarchically; the level of significance will be determined by the fallback procedure.</p> <p>The secondary and tertiary endpoints will be summarized descriptively at the interim (Week 26) analyses.</p> <p>The details of the interim analyses, including the control of Type I error rate, will be specified in the SAP.</p> <p>Analysis of safety endpoints will be primarily descriptive. The incidence of AEs will be summarized by system organ class, preferred term, relationship to study drug, seriousness, and severity. Clinical laboratory test values, vital signs, vector shedding and immune response parameters will be summarized descriptively by visit.</p> |  |   |

### 3 TABLE OF CONTENTS

|  |    |
|--|----|
| CLINICAL STUDY PROTOCOL AMENDMENT SUMMARY.....                         | 2  |
| 2 SYNOPSIS.....  | 7  |
| 3 TABLE OF CONTENTS.....   | 21 |
| 4 LIST OF ABBREVIATIONS AND DEFINITIONS OF TERMS.....                  | 26 |
| 5 ETHICS.....  | 29 |
| 5.1 Institutional Review Board or Independent Ethics Committee .....   | 29 |
| 5.2 Ethical Conduct of Study .....                                     | 29 |
| 5.3 Subject Information and Informed Consent.....                      | 30 |
| 6 INVESTIGATORS AND STUDY ADMINISTRATIVE STRUCTURE .....               | 31 |
| 7 INTRODUCTION .....   | 32 |
| 7.1 Nonclinical Studies .....  | 33 |
| 7.2 Previous Clinical Studies .....                                    | 33 |
| 7.3 Study Rationale .....  | 33 |
| 7.3.1 Optional Liver Biopsy Rationale.....                             | 36 |
| 7.4 Summary of Overall Risks and Benefits.....                         | 37 |
| 7.4.1 Optional Liver Biopsy Risks and Benefits.....                    | 38 |
| 8 STUDY OBJECTIVES.....  | 39 |
| 9 INVESTIGATIONAL PLAN.....  | 40 |
| 9.1 Overall Study Design and Plan .....                                | 40 |
| 9.2 Discussion of Study Design, Including Choice of Control Group..... | 60 |
| 9.3 Selection of Study Population.....                                 | 60 |
| 9.3.1 Inclusion Criteria .....   | 60 |
| 9.3.2 Exclusion Criteria.....  | 61 |
| 9.3.3 Removal of Subjects from Treatment or Assessment .....           | 63 |
| 9.3.4 Subject Identification and Replacement of Subjects .....         | 65 |
| 9.3.5 Duration of Subject Participation.....                           | 66 |
| 9.4 Treatments.....  | 66 |
| 9.4.1 Treatments Administered .....                                    | 66 |
| 9.4.2 Identity of Investigational Product.....                         | 66 |



|        |   |    |
|--------|---|----|
| 9.4.3  | Storage.....  | 66 |
| 9.4.4  | Directions for Administration .....                                   | 66 |
| 9.4.5  | Method of Assigning Subjects to Treatment Groups .....                | 68 |
| 9.4.6  | Selection of Dose Used in the Study .....                             | 68 |
| 9.4.7  | Blinding.....   | 68 |
| 9.4.8  | Prior and Concomitant Medications.....                                | 69 |
| 9.4.9  | Treatment Compliance .....  | 73 |
| 9.5    | Investigational Product Accountability.....                           | 73 |
| 9.5.1  | Return and Disposition of Clinical Supplies .....                     | 73 |
| 9.6    | Dietary or Other Protocol Restrictions.....                           | 74 |
| 9.7    | Safety and Efficacy Variables.....                                    | 74 |
| 9.7.1  | Safety and Efficacy Measurements Assessed .....                       | 74 |
| 9.7.2  | Primary Efficacy Variables .....                                      | 74 |
| 9.7.3  | Secondary Efficacy Variables .....                                    | 75 |
| 9.7.4  | Tertiary Efficacy Variables .....                                     | 76 |
| 9.7.5  | Immunogenicity.....   | 77 |
| 9.7.6  | Pharmacodynamics.....   | 77 |
| 9.7.7  | Exploratory Assessments .....   | 77 |
| 9.7.8  | Safety Variables .....  | 79 |
| 10     | REPORTING ADVERSE EVENTS .....  | 87 |
| 10.1   | Safety Parameters and Definitions.....                                | 87 |
| 10.1.1 | Adverse Events.....   | 87 |
| 10.2   | Serious Adverse Events .....  | 88 |
| 10.2.1 | Events of Special Interest (EOSI) .....                               | 89 |
| 10.3   | Methods and Timing for Capturing and Assessing Safety Parameters..... | 89 |
| 10.3.1 | Adverse Event Reporting Period.....                                   | 89 |
| 10.3.2 | Eliciting Adverse Events .....  | 89 |
| 10.3.3 | Assessment of Seriousness, Severity, and Causality.....               | 89 |
| 10.4   | Procedures for Recording Adverse Events .....                         | 92 |
| 10.4.1 | Recording Adverse Events on a eCRF.....                               | 92 |
| 10.5   | Reporting Requirements .....  | 96 |



---

|         |  |     |
|---------|--|-----|
| 10.5.1  | Expedited Reporting Requirements.....  | 96  |
| 10.5.2  | Institutional Review Board or Independent Ethics Committee Reporting Requirements..... | 96  |
| 10.6    | Follow-up of Subjects after Adverse Events.....  | 96  |
| 10.7    | Post-Study Adverse Events.....   | 97  |
| 10.8    | Urgent Safety Measures.....  | 97  |
| 10.9    | BioMarin Pharmacovigilance Contact Information.....                                    | 98  |
| 11      | APPROPRIATENESS OF MEASUREMENTS .....  | 99  |
| 12      | STUDY PROCEDURES .....   | 100 |
| 12.1    | Prestudy.....  | 100 |
| 12.2    | Screening Visit.....   | 100 |
| 12.2.1  | “Smart Rescreening” Visit .....  | 101 |
| 12.3    | Baseline Visit.....  | 102 |
| 12.4    | Treatment Visit/BMN 270 Infusion Visit (Day 1).....                                    | 103 |
| 12.5    | BMN 270 Infusion Follow-Up Visits – Weeks 1-26 .....                                   | 104 |
| 12.5.1  | Once per week (Weeks 1 through 26).....  | 104 |
| 12.5.2  | Week 1 – Day 4.....  | 105 |
| 12.5.3  | Week 1 – Day 8.....  | 105 |
| 12.5.4  | Every 2 Weeks (Week 2, 4, 6, 8, 10, 12, 14, 16, 18, 20, 22, 24, and 26) .....          | 105 |
| 12.5.5  | Weeks 2, 4, 10, 16, 22, and 26 .....   | 105 |
| 12.5.6  | Weeks 2, 3, 4, 6, 8, 12, 16, 20, 24, and 26 .....                                      | 105 |
| 12.5.7  | Weeks 4, 12, and 26 .....  | 106 |
| 12.5.8  | Every 4 Weeks (Weeks 4, 8, 12, 16, 20, and 24) Plus Week 26 .....                      | 106 |
| 12.5.9  | Every 8 Weeks (Weeks 8, 16, and 24) .....  | 106 |
| 12.5.10 | Weeks 6, 12, 16, 20, 24, and 26 .....  | 106 |
| 12.5.11 | Weeks 12 and 26 .....  | 106 |
| 12.5.12 | Week 16.....   | 107 |
| 12.5.13 | Week 20, 24, and 26.....   | 107 |
| 12.6    | Post-Infusion Follow-Up – Weeks 27-52 .....  | 107 |
| 12.6.1  | Every Visit.....   | 107 |

|        |   |     |
|--------|---|-----|
| 12.6.2 | Weeks 28, 32, 36, 44, and 52 .....  | 108 |
| 12.6.3 | Every 4 Weeks (Weeks 28, 32, 36, 40, 44, 48, 52) .....                              | 108 |
| 12.6.4 | Weeks 32, 36, 44, and 52 .....  | 109 |
| 12.6.5 | Weeks 32, 36, 40, 44, 48, and 52 .....  | 109 |
| 12.6.6 | Week 32, 36, and 52 .....   | 109 |
| 12.6.7 | Week 36 and 52 .....  | 109 |
| 12.6.8 | Week 52 .....   | 109 |
| 12.7   | Post-Infusion Follow-Up – Years 2-5 .....   | 110 |
| 12.7.1 | Year 2 – Every 4 Weeks (not required for treatment failure) .....                   | 111 |
| 12.7.2 | Years 3-5 – Every 6 Weeks (not required for treatment failure) .....                | 111 |
| 12.7.3 | Years 2-5 – Every 12 Weeks and End of Year Visits (required for all subjects) ..... | 112 |
| 12.8   | Early Termination Visit .....   | 114 |
| 12.9   | Optional Liver Biopsy .....   | 115 |
| 12.10  | End of Study .....  | 116 |
| 13     | DATA QUALITY ASSURANCE .....  | 117 |
| 14     | STATISTICAL METHODS AND DETERMINATION OF SAMPLE SIZE .....                          | 118 |
| 14.1   | Statistical and Analytical Plans .....  | 118 |
| 14.1.1 | Interim Analyses .....  | 118 |
| 14.1.2 | Procedures for Accounting for Missing, Unused and Spurious Data .....               | 118 |
| 14.2   | Primary Efficacy Endpoint .....   | 119 |
| 14.3   | Secondary Efficacy Endpoints .....  | 119 |
| 14.4   | Liver Biopsy Substudy Analysis .....  | 120 |
| 14.5   | Immunogenicity .....  | 120 |
| 14.6   | Pharmacodynamic Analyses .....  | 120 |
| 14.7   | Safety Analysis .....   | 120 |
| 14.8   | Determination of Sample Size .....  | 121 |
| 14.9   | Analysis Populations .....  | 122 |
| 14.10  | Changes in the Conduct of the Study or Planned Analyses .....                       | 122 |
| 15     | DATA MONITORING COMMITTEE .....   | 123 |
| 16     | COSTS, COMPENSATION, AND SUBJECT INJURY .....                                       | 124 |



17 CASE REPORT FORMS AND SOURCE DOCUMENTS .....125

18 STUDY MONITORING AND AUDITING .....127

19 RETENTION OF RECORDS.....128

20 USE OF INFORMATION AND PUBLICATION.....129

21 REFERENCES .....130

22 INVESTIGATOR RESPONSIBILITIES .....133

    22.1 Conduct of Study and Protection of Human Patients .....133

23 SIGNATURE PAGE .....134

24 APPENDIX 1: SAMPSON’S ANAPHYLAXIS CRITERIA .....135

25 PROTOCOL AMENDMENT TEXT REVISIONS .....136

**LIST OF TABLES**

Table 9.1.1: Schedule of Events – Screening and Infusion .....43

Table 9.1.2: Schedule of Events – Post-Infusion Follow-Up (Week 1-16).....46

Table 9.1.3: Schedule of Events – Post-Infusion Follow-Up (Week 17-32).....49

Table 9.1.4: Schedule of Events – Post-Infusion Follow-Up (Week 33 – Week 52).....52

Table 9.1.5: Schedule of Events – Post-Infusion Follow-Up (Year 2 – Year 5).....55

Table 9.1.6: Schedule of Events – Therapeutic Corticosteroids for ALT Elevations.....58

Table 9.1.7: Schedule of Events – Optional Liver Biopsy .....59

Table 9.4.8.2.1: Adjustments to Corticosteroid Regimen.....72

Table 9.7.8.2.1: Clinical Laboratory Tests .....80

Table 9.7.8.3.1: Liver Tests .....82

Table 9.7.8.3.2: Evaluation of ALT Elevations .....83

Table 9.7.8.3.3: Viral and Autoimmune Hepatitis Testing.....84

Table 10.3.3.2.1: Adverse Event Grading (Severity) Scale.....90

Table 10.3.3.3.1: Causality Attribution Guidance .....91

**LIST OF FIGURES**

Figure 1: hFVIII-SQ Vector Genome and Encoded Protein.....9

Figure 7.3.1: hFVIII-SQ Vector Genome and Encoded Protein.....35



---

#### 4 LIST OF ABBREVIATIONS AND DEFINITIONS OF TERMS

|         |  |
|---------|--|
| AAV     | adeno-associated virus                                     |
| ABR     | annualized bleeding rate                                   |
| ADL     | activities of daily living                                 |
| ADR     | adverse drug reaction                                      |
| AE      | adverse event  |
| ALT     | alanine aminotransferase                                   |
| APTT    | activated partial thromboplastin time                      |
| ART     | anti-retroviral therapy                                    |
| AST     | aspartate aminotransferase                                 |
| BPV     | BioMarin Pharmacovigilance                                 |
| BU      | Bethesda Unit  |
| CFR     | Code of Federal Regulations                                |
| CRA     | clinical research associate                                |
| CRF     | case report form   |
| CSR     | clinical study report                                      |
| CTCAE   | Common Terminology Criteria for Adverse Events             |
| DMC     | Data Monitoring Committee                                  |
| eCRF    | electronic case report form                                |
| ED      | exposure days  |
| EOSI    | events of special interest                                 |
| ETV     | early termination visit                                    |
| EudraCT | European Union Drug Regulating Authorities Clinical Trials |
| FDA     | Food and Drug Administration                               |
| FIH     | first-in-human   |
| FVIII   | coagulation factor VIII                                    |
| GCP     | Good Clinical Practice                                     |
| GGT     | gamma-glutamyltransferase                                  |
| HA      | Hemophilia A   |
| HAL     | Haemophilia Activities List                                |
| HBcAb   | hepatitis B core antibody                                  |
| HBsAb   | hepatitis B surface antibody                               |
| HBsAg   | hepatitis B surface antigen                                |
| hFIX    | human coagulation factor IX                                |
| hFVIII  | human coagulation factor VIII                              |

---

|             |   |
|-------------|---|
| HIPAA       | Health Insurance Portability and Accountability Act   |
| HLP         | hybrid human liver-specific promoter  |
| IB          | investigator brochure   |
| ICF         | informed consent form   |
| ICH         | International Conference on Harmonisation of Technical Requirements for Registration of Pharmaceuticals for Human Use |
| ICH E6 [R2] | ICH Harmonised Tripartite Guideline: Guideline for Good Clinical Practice E6  |
| IEC         | independent ethics committee  |
| IND         | Investigational New Drug (application)  |
| INR         | international normalized ratio  |
| IP          | investigational product   |
| IRB         | institutional review board  |
| ITT         | Intention-to-treat  |
| IV          | intravenous   |
| LT          | liver test  |
| MedDRA      | Medical Dictionary for Regulatory Activities  |
| mITT        | Modified intention-to-treat   |
| MN          | mobile nursing  |
| PBMC        | peripheral blood mononuclear cells  |
| PCR         | polymerase chain reaction   |
| PD          | pharmacodynamics  |
| PEG         | polyethylene glycol   |
| PK          | Pharmacokinetics  |
| PRO         | patient-reported outcome  |
| rhFVIII     | recombinant human FVIII protein   |
| REB         | research ethics board   |
| SAE         | serious adverse event   |
| SAP         | statistical analysis plan   |
| SDV         | source data verification  |
| SQ          | 14-amino acid sequence: SFSQNPPVLKRHQR  |
| TGA         | thrombin generation assay   |
| ULN         | upper limit of normal   |
| vg          | vector genomes  |
| VWF:Ag      | von Willebrand factor Antigen   |
| WPAI+CIQ:HS | Work Productivity and Activity Impairment plus Classroom Impairment Questions: Hemophilia Specific                    |

**Definition of Terms:**

## Investigational Product (IP):

“A pharmaceutical form of an active ingredient or placebo being tested or used as a reference in a clinical trial, including a product with a marketing authorization when used or assembled (formulated or packaged) in a way different from the approved form, or when used for an unapproved indication, or when used to gain further information about an approved use” (from International Conference on Harmonisation of Technical Requirements for Registration of Pharmaceuticals for Human Use ICH Harmonised Tripartite Guideline: Guideline for Good Clinical Practice E6 [ICH E6 (R2)]).

The terms “IP” and “study drug” may be used interchangeably in the protocol.

---

## **5 ETHICS**

BioMarin Pharmaceutical Inc. (hereafter referred to as BioMarin or the Sponsor) conducts its studies according to the highest ethical and scientific standards. The following sections articulate standards to which Investigators will be held accountable, as well as matters of compliance to document adherence to such standards.

### **5.1 Institutional Review Board or Independent Ethics Committee**

Investigators are expected to interact with Ethics Committees (ECs) promptly, as required, during the course of the study. This includes, but is not limited to, providing appropriate documentation to support study initiation and maintaining appropriate flow of safety and other information during the course of the study and for study close-out activities. BioMarin (or designee) will assist Investigators with access to timely and accurate information and with assurance of prompt resolution of any queries.

Prior to initiating the study, the Investigator will obtain written confirmation that the institutional review board (IRB) or independent ethics committee (IEC) [for Canadian protocols, Research Ethics Board (REB)] is properly constituted and compliant with International Conference on Harmonisation of Technical Requirements for Registration of Pharmaceuticals for Human Use (ICH) and Good Clinical Practice (GCP) requirements, applicable laws and local regulations. A copy of the confirmation from the IRB/IEC/REB will be provided to BioMarin or its designee. The Investigator will provide the IRB/IEC/REB with all appropriate material, including the protocol, Investigator's Brochure (IB), the Informed Consent Form (ICF) including compensation procedures, and any other written information provided to the subjects, including all ICFs translated for patients who do not speak the local language at the clinical site. The study will not be initiated and Investigational Product (IP) supplies will not be shipped to the site until appropriate documents from the IRB/IEC/REB confirming unconditional approval of the protocol, the ICF and all subject recruitment materials are obtained in writing by the Investigator and copies are received at BioMarin or its designee. The approval document should refer to the study by protocol title and BioMarin protocol number (if possible), identify the documents reviewed, and include the date of the review and approval. BioMarin will ensure that the appropriate reports on the progress of the study are made to the IRB/IEC/REB and BioMarin by the Investigator in accordance with applicable guidance documents and governmental regulations.

### **5.2 Ethical Conduct of Study**

It is expected that Investigators understand and comply with the protocol. This includes, but is not limited to: establishing and meeting enrollment commitments, including providing

eligible subjects for study enrollment; adhering to adverse event reporting, diagnostic, or other procedures as specified in the protocol; and assuring appropriate compliance with study treatment administration and accountability.

This study will be conducted in accordance with the following:

- European Clinical Trial Directive 2001/20/EC and Good Clinical Practice Directive 2005/28/EC, for studies conducted within any European country
- US Code of Federal Regulations (CFR) sections that address clinical research studies, and/or other national and local regulations, as applicable
- ICH Harmonised Tripartite Guideline: Guideline for Good Clinical Practice E6 (ICH E6) or E6(R2) (ICH E6R2) if adopted

Specifically, this study is based on adequately performed laboratory and animal experimentation and human Phase 1 study testing. The study will be conducted under a protocol reviewed and approved by an IRB/IEC/REB and will be conducted by scientifically and medically qualified persons. The potential benefits of the study are in proportion to the potential risks. The rights and welfare of the subjects will be respected and the Investigators conducting the study do not find the hazards to outweigh the potential benefits. Each subject will provide written, informed consent before any study-related tests or evaluations are performed.

### **5.3 Subject Information and Informed Consent**

A properly written and executed informed consent form (ICF), in compliance with ICH E6 (Section 4.8), United States Code of Federal Regulations (CFR) 21 CFR §50, European Clinical Trial Directive 2001/20/EC and Good Clinical Practice Directive 2005/28/EC, and other applicable local regulations, will be obtained for each subject prior to entering the subject into the study. The Investigator will prepare the ICF and provide the documents to BioMarin for approval prior to submission to the IRB/IEC/REB. BioMarin and the IRB/IEC/REB must approve the documents before they are implemented. A copy of the approved ICF, and if applicable, a copy of the approved subject information sheet and all ICFs translated to a language other than the native language of the clinical site must also be received by BioMarin or designee prior to any study-specific procedures being performed.

The Investigator will provide copies of the signed ICF to each subject and will maintain the original in the record file of the subject.

---

## **6 INVESTIGATORS AND STUDY ADMINISTRATIVE STRUCTURE**

During administration of informed consent, expectations regarding participation in the study should be made clear to subjects. Patients who are not willing and/or are not able to comply with all aspects of the study should not be encouraged to participate.

Prior to beginning the study, the Investigator at each site must provide to BioMarin or designee a fully executed and signed Statement of Investigator (SOI) form. A US Food and Drug Administration (FDA) Form FDA 1572 serves as an acceptable SOI form. If Form FDA 1572 may not be used in a particular region, the Investigator must provide a fully executed SOI on the form provided by the Sponsor. All Investigators and Sub-Investigators must be listed on Form FDA 1572 or its equivalent SOI. Financial Disclosure Forms must also be completed for all Investigators and Sub-Investigators listed on the Form FDA 1572 or SOI who will be directly involved in the treatment or evaluation of subjects in this study.

The study will be administered by and monitored by employees or representatives of BioMarin. Clinical research associates (CRAs) or trained designees will monitor each site on a periodic basis and perform verification of source documentation for each subject as well as other required review processes. BioMarin's Regulatory Affairs Department (or designee) will be responsible for the timely reporting of serious adverse events (SAEs) to appropriate regulatory authorities as required.

In multicenter studies, a Coordinating Investigator will be identified who will be responsible for study overview. The Coordinating Investigator will read the clinical study report (CSR) and confirm that it accurately describes the conduct and results of the study, to the best of his or her knowledge. The Coordinating Investigator will be chosen on the basis of active participation in the study, ability to interpret data, and willingness to review and sign the report in a specified timeframe. The identity of the Coordinating Investigator and a list of all Investigators participating in the study will be provided in the CSR.

Clinical Laboratory assessments will be performed at a nominated central laboratory. Bioanalytical samples will be sent to the appropriate specialty laboratories for testing. Refer to laboratory manual for more details.

## 7 INTRODUCTION

Hemophilia A (HA) is an X-linked recessive bleeding disorder that affects approximately 1 in 5,000 males (Nathwani, 1992, *Baillieres Clin.Haematol.*). It is caused by mutations in the factor VIII (FVIII) gene that codes for FVIII protein, an essential cofactor in the coagulation pathway. Clinical manifestations of severe FVIII deficiency are frequent unprovoked bleeding episodes in joints and soft tissues causing permanent disability and occasionally death mostly after brain hemorrhage. Treatment in Western countries (Berntorp, 2012, *Haemophilia.*) consists of intravenous injection of plasma-derived or recombinant FVIII protein concentrates at the time of a bleed to control it or prophylactically to prevent bleeding episodes. The short half-life for FVIII (~8-12 hours) necessitates frequent infusions and makes this treatment prohibitively expensive for the majority of the world's hemophilia A patients. These individuals develop debilitating arthropathy and have a substantially increased risk of death from hemorrhage in life (Stonebraker, 2010, *Haemophilia.*). Chemical modification or bioengineering of FVIII may improve half-life to 18-19 hours (Kaufman, 2013, *Blood*). However, these extended half-life FVIII variants do not eliminate the need for lifelong FVIII protein administration (Hay, 2012, *Blood*).

Gene therapy offers the potential of disease-modifying therapy by continuous endogenous production of human FVIII (hFVIII) following a single administration of vector. Hemophilia A is well-suited for this approach because its clinical manifestations are attributable to the lack of a single gene product (FVIII) that circulates in low amounts (100-200 ng/ml) in the plasma. Tightly regulated control of gene expression is not essential, and a modest increase in the level of FVIII (a plasma level of 2 ng/ml protein leads to a 1% expression) can ameliorate the severe phenotype (Srivastava, 2013, *Haemophilia.*); thus, the therapeutic goal for gene therapy is a modest increase in hFVIII. Finally, the consequences of gene transfer can be assessed using simple quantitative rather than qualitative endpoints that can be easily assayed in most clinical laboratories.

BMN 270 contains the cDNA for the B-domain-deleted SQ FVIII with a liver-specific HLP transcription promoter. The expression cassette is inserted between AAV2 ITRs, and this genome is packaged in the AAV5 capsid. A comprehensive review of BMN 270 is contained in the IB supplied by BioMarin. Investigators are to review this document prior to initiating this study.

## 7.1 Nonclinical Studies

The nonclinical program supports a single IV infusion of BMN 270, the planned clinical route of administration, for the treatment of hemophilia A in male patients. This nonclinical program took into account the guidelines and reflection papers for gene therapy medicinal products under EMA Advanced Therapies as well as FDA guidance. The primary pharmacodynamics (PD), pharmacokinetics (PK), and toxicity of IV BMN 270 were characterized in a series of single dose studies in species that were vector permissive and responsive to the transgene including normal CD-1 mice, a B- and T-cell deficient mouse model of hemophilia A (B6;129S-*F8<sup>tm1Kaz</sup>/J* x B6.129S6-*Rag2<sup>tm1Fwa</sup>* N12; FVIII KO x Rag2), and normal cynomolgus and rhesus monkeys. Some PD studies evaluated additional PK, immunogenicity and toxicity endpoints.

Results of the nonclinical program to date are detailed in the IB supplied by BioMarin. Investigators are to review this document prior to initiating this study.

## 7.2 Previous Clinical Studies

Study BMN 270-201 is an ongoing Phase 1/2, dose-escalation study to assess the safety, tolerability, and efficacy of BMN 270 in patients with severe hemophilia A (FVIII  $\leq 1$  IU/dL). Subjects received a single BMN 270 infusion and are to be followed for safety and efficacy for up to 5 years. A total of 15 subjects have been enrolled at one of 4 dose levels (6E12, 2E13, 4E13, and 6E13 vg/kg).

A comprehensive review of safety, efficacy, and immunogenicity results from 270-201 as of the latest data cut is contained in the IB supplied by BioMarin. Investigators are to review this document prior to initiating this study.

## 7.3 Study Rationale

Hemophilia A (HA) is an X-linked recessive bleeding disorder that affects approximately 1 in 5,000 males. It is caused by deficiency in the activity of coagulation factor VIII (FVIII), an essential cofactor in the intrinsic coagulation pathway. This disorder can be either inherited, due to a genetic aberrancy or an acquired immunologic process, leading to insufficient quantities of FVIII or a dysfunctional FVIII, but all are characterized by a defective coagulation process. The clinical phenotype of HA patients generally correlates tightly with the level of residual expression. Severe HA is classified as FVIII activity less than 1% of wild type ( $< 1$  IU/dL), moderate disease comprises 1-5% of wild-type activity and the mild form is 5-40% activity. The clinical manifestations of severe HA are frequent spontaneous bleeding episodes, predominantly in joints and soft tissues, with a substantially increased risk of death from hemorrhage when the brain is involved. Subjects with moderate



disease can exhibit manifestations similar to those seen in patients with severe HA, resulting in a comparable bleeding phenotype.

Treatment of severe HA presently consists of intravenous injection of plasma derived or recombinant human FVIII protein (rhFVIII) concentrates both as prophylaxis 2-3 times per week, and at the time of a bleed, to prevent or control bleeding episodes, respectively. The half-life for FVIII (12 to 18 hours for most approved products) necessitates frequent infusions, and although a major advance in the treatment of HA, it remains common for severe HA patients to continue to have multiple bleeding events on prophylactic therapy (median ABR of 1-4 with prophylaxis treatment in a recently published retrospective observational study (Berntorp, 2017) and between 1-2 in 6 prospective FVIII interventional studies) and on-demand-only therapy (median ABR of 4.5-18 in a recently published retrospective study (Berntorp, 2017) and between 20-60 in 6 prospective FVIII interventional studies). The consequence of multiple bleeding events is the development of debilitating multiple-joint arthropathy and substantially increased risk of death. Chemical modification (eg, direct conjugation of polyethylene glycol (PEG) polymers) and bioengineering of FVIII (eg, FVIII-Fc fusion proteins) improve half-life by approximately 50%, and thus, show promise in reduced dosing and maintaining activity levels above 1% trough for a greater proportion of the dosing interval. However, these extended half-life FVIII variants remain dependent on multiple infusions to maintain critical levels of FVIII activity in severe HA patients. There is therefore a strong unmet need for a fully preventive treatment of HA to give patients a FVIII level compatible with a normal and hemorrhage-free life.

Gene therapy offers the potential of disease-modifying therapy by continuous endogenous production of active FVIII following a single intravenous infusion of a vector encoding the appropriate gene sequence for long-term episomal expression. Hemophilia A is well-suited for a gene replacement approach because clinical manifestations are attributable to the lack of a single gene product (FVIII) that circulates in minute amounts (200 ng/ml) in the plasma. Tightly regulated control of gene expression is not essential, and even modest increases in the level of FVIII (any increase of the plasma level by 2 ng/ml induces an increase in activity of 1%) can ameliorate the severe form of the disease. Thus, relatively small changes in endogenous FVIII activity can result in clinically relevant improvements in disease phenotype. Finally, the circulating FVIII response to gene transduction can be assessed using validated quantitative rather than qualitative endpoints that are easily assayed using established laboratory techniques.

Several different gene transfer strategies for FVIII replacement have been evaluated, but adeno-associated viral (AAV) vectors show the greatest promise. They have an excellent and

well-defined safety profile, and can direct long term transgene expression with tropism and promoter specificity for specific tissues such as the liver (for serotypes 2, 5 and 8 among others). Indeed, an on-going gene therapy clinical trial for a related disorder, hemophilia B, has established that stable (median follow-up of 3.2 years) expression of human factor IX (hFIX) at levels that are sufficient for conversion of their bleeding phenotype from severe to moderate or mild is achievable following a single peripheral vein infusion of AAV8-hFIX vector. Several participants in this trial have been able to discontinue factor prophylaxis without suffering spontaneous hemorrhages, even when they undertook activities that previously resulted in bleeding. Thus, gene therapy treatment has resulted in a substantial improvement in their quality of life (Nathwani, 2014).

BMN 270 is an AAV5-based gene therapy vector that expresses the SQ form of hFVIII under the control of a hybrid human liver-specific promoter (Figure 7.3.1).

**Figure 7.3.1: hFVIII-SQ Vector Genome and Encoded Protein**

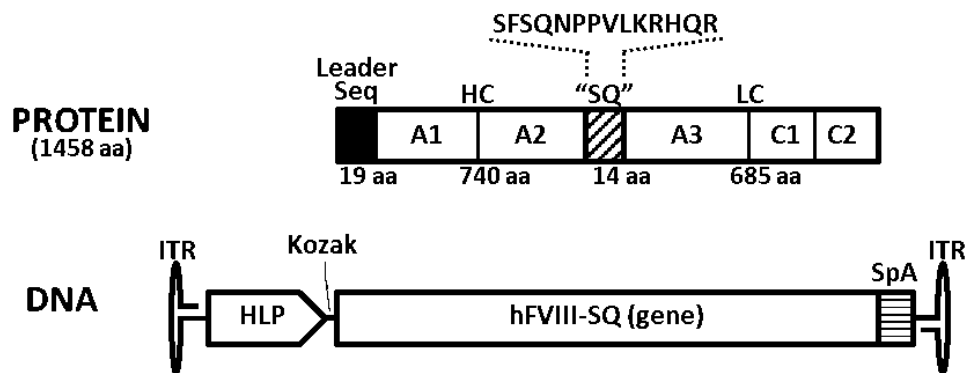

Legend –Note that schematic is not to scale; aa = amino acids; ITR = inverted terminal repeat; HLP = human liver promoter; Kozak = Kozak consensus sequence (GCCACC); SpA = Synthetic poly(A) signal

BMN 270 will be delivered by a single intravenous dose and is designed to achieve stable, potentially life-long expression of active hFVIII in the plasma, synthesized from vector-transduced liver tissue.

BMN 270 is being evaluated in clinical study 270-201, an ongoing first-in-human, phase 1/2 dose escalation study in subjects with severe HA designed to assess the safety and efficacy of BMN 270 at various dose levels (6E12 vg/kg, 2E13 vg/kg, 4E13 vg/kg, 6E13 vg/kg).

Specifically, 270-201 explores the relationship of vector dose to the augmentation of residual FVIII activity and whether these levels are sufficient to alter the clinical phenotype.

Preliminary results from 270-201 have demonstrated that following gene transfer, FVIII activity above 15% (15 IU/dL) and, in many cases, within the normal range for FVIII, is

achievable with a dose of 4-6E13 vg/kg with an acceptable safety profile ([Pasi, 2017](#)). For additional information on preliminary data in 270-201, refer to the current version of the Investigator's Brochure.

The current study is a Phase 3, single-arm, open-label study designed to assess whether, in an expanded sample, BMN 270 can safely alter the clinical phenotype of hemophilia A patients with residual FVIII activity  $\leq 1$  IU/dL.

### 7.3.1 Optional Liver Biopsy Rationale

The usual pattern of response in hFVIII activity observed so far after administration of BMN 270 demonstrates peak expression levels during the first 6-12 months post-treatment followed by a decline to a steady-state level of expression thereafter. One of the explanations may lie in the kinetics of vector genome processing, which involves a series of steps such as DNA degradation and repair, annealing, and circularization that can result in the formation of stable, double-stranded, circularized transgene DNA forms. It is these circularized DNA species that are thought to be associated with long-term, persistent expression of the gene product in target cells. Examination of transduced hepatocytes from subjects treated with BMN 270 in the 270-301 study will help to establish whether DNA circularization may occur and could account for the long-term hFVIII expression observed in humans.

Additionally, health of the liver after gene transduction has been monitored indirectly by periodic assessments of hepatic enzymes released into the blood stream. Transient, post-treatment elevations in ALT levels have been observed in the majority of subjects, as well as inter-subject variability in post-therapy FVIII activity levels. Neither the reasons for nor the significance of the ALT elevations or the variations in response to FVIII gene therapy are known. Moreover, the effects of BMN 270 on hepatic tissue structure and function are also currently unknown. Finally, a call to incorporate liver biopsy sub-studies into gene therapy trials for hemophilia has been issued by medical and scientific leaders in the field to help illuminate these and other questions ([National Hemophilia Foundation, 2019](#)).

The purpose of this exploratory sub-study is to provide a better understanding of the long-term gene expression related to genome circularization, health of the liver, and variation in FVIII activity levels observed after gene therapy with BMN 270. With use of prophylactic corticosteroids, it is believed that there will be stable hepatic function and FVIII activity expression, with tolerance of prophylactic corticosteroid therapy and no change to the risk of thromboembolism. This sub-study aims to evaluate the effect on the liver by performing liver biopsies during Year 1 post-infusion, at or around Week 52, and/or during Years 2-5.

#### 7.4 Summary of Overall Risks and Benefits

BMN 270 has an acceptable safety and tolerability profile that supports a positive benefit-risk assessment. Single infusions have been generally well tolerated by treated subjects across all investigated doses. All subjects have successfully completed their full-dose infusion of BMN 270, with no infusions requiring permanent termination prior to completion due to AEs. No deaths have been reported in any of the BMN 270 studies, and no participants discontinued from studies as a result of an AE. Frequency of adverse events decreased over time with no delayed adverse drug reactions.

Infusion reactions associated with BMN 270 administration included symptoms such as maculopapular rash, urticaria, nausea, diarrhea, watery eyes, rigors, chills, myalgia, fever, tachycardia and hypotension emerging within 24 hours of receiving BMN 270. All of these events subsided without clinical sequela within 48 hours following medical management. Infusion-related reactions were effectively mitigated by managing infusion rate and medications.

Transient, asymptomatic ALT elevation (grade 1 to 3 in severity) was observed in most subjects administered BMN 270 shortly after dosing, with no symptoms or sequelae suggestive of clinically significant hepatocyte injury or liver dysfunction. In almost all subjects, ALT elevations decreased quickly following corticosteroid treatment. There were differences in the use of corticosteroids across studies. Subjects in 270-201 received corticosteroids an average of 8 weeks earlier following BMN 270 infusion than the mITT population in 270-301, were more likely to avoid a significant decline in FVIII activity concurrently with an ALT elevation, and saw a more robust recovery of FVIII activity upon the first use of corticosteroids, than did the subjects in the mITT population in 270-301. Despite the clinical response to steroids, no associations between safety parameters (transient ALT rises), or efficacy as measured by FVIII activity levels were found to be temporally associated with anti-AAV5 antibody or cellular immune responses.

At the highest dose tested in 270-201 (6E13 vg/kg), the majority of subjects achieved FVIII levels above 50 IU/dL at 52 weeks post-infusion. Subjects in that cohort also reported markedly decreased bleeding compared with pre-study rates and the ability to discontinue prophylactic FVIII infusions. Subjects at all dose levels continue to be followed.

In 270-301, an interim analysis has shown increased FVIII activity in the majority of subjects to mild HA or normal levels at 26 weeks post-infusion, also with markedly decreased bleeding compared with pre-study rates and the ability to discontinue prophylactic FVIII infusions. All subjects who will be included in the final analysis have been dosed with 6E13 vg/kg and continue to be followed.

The current data available has shown an established positive benefit:risk profile for BMN 270 at the 6E13 vg/kg dosing level. Given the monitoring measures in place in the clinical protocol(s) to minimize the risk to subjects participating in the existing studies, the identified risks are justified by the anticipated benefits that may be afforded to subjects. Each subject in 270-301 will have a comprehensive surveillance plan that monitors LTs during the study, and elevations in LTs will be addressed according to the guidelines set forth in the protocol. Safety will be assessed by adverse event reporting and clinical laboratory assessments.

For additional information on the risks and benefits of treatment with BMN 270, refer to the current version of the Investigator's Brochure.

#### **7.4.1 Optional Liver Biopsy Risks and Benefits**

Liver biopsy is considered a safe procedure, with serious complications occurring less than once in every 10,000 procedures (Grant, 2004). Although the theoretical risks of significant complications are extremely small, the main complications would include bleeding and bile leakage. Another theoretical complication is infection at the needle insertion site; the sterile technique used makes this risk extremely small.

The most common problems include mild pain and a minor decrease in blood pressure. More serious complications, such as bleeding, infection, and injury to nearby organs, are very rare, but the subject will be monitored appropriately to ensure correct management should any of these occur. Any complications related to the liver biopsy should be reported as adverse events, as outlined in Section 10. The liver biopsy is a standard investigation, and will be explained more fully by the experienced clinician performing the biopsy.

Each subject who participates in this optional sub-study will have a comprehensive pre-/post-biopsy surveillance plan according to the standard procedures at the institution. Timing of the liver biopsies will occur at Weeks 26, 52, and/or during Years 2-5. Safety will be assessed by adverse event reporting and clinical laboratory assessments. Per the Investigator's discretion and/or according to local guidelines, the subject may be kept in overnight following the liver biopsy for additional safety monitoring; such an overnight stay would not be considered a hospitalization for serious adverse event (SAE) reporting purposes (refer to Section 10.4.1.7).

There is no direct benefit from participating in this study other than contributing to understanding the mechanism of action of BMN 270. Consenting into this specific sub-study is optional and will not have any effect on the subject's continued participation in 270-301.

---

## 8 STUDY OBJECTIVES

The primary efficacy objective of the study is to:

- Assess the efficacy of BMN 270 defined as FVIII activity, as measured by chromogenic substrate assay, during Weeks 49-52 following intravenous infusion of BMN 270

The secondary efficacy objectives of the study are to:

- Assess the impact of BMN 270 on usage of exogenous FVIII replacement therapy from Week 5 to Week 52
- Assess the impact of BMN 270 on the number of bleeding episodes requiring exogenous FVIII replacement therapy from Week 5 to Week 52

The tertiary efficacy objective of the study is to:

- Assess the impact of BMN 270 on patient-reported outcomes (PROs) at Week 52 of the study compared to baseline

The safety objectives of the study are to:

- Evaluate the safety of BMN 270 during the first 52 weeks following intravenous infusion
- Assess the long-term safety of BMN 270

The exploratory objectives of the liver biopsy substudy are:

- To examine the histopathology of the liver following BMN 270 therapy, including assessing for possible safety findings (eg, fibrosis, fatty liver disease, lymphocytic invasion)
- To quantify FVIII DNA, RNA, and protein expression within hepatocytes
- To determine which forms of rAAV vector DNA are present at the time of biopsy.
- To determine the transduction pattern of BMN 270 in humans (ie, peri-portal hepatocytes, central vein hepatocytes)



**9 INVESTIGATIONAL PLAN**

**9.1 Overall Study Design and Plan**

This is a Phase 3, single-arm, open-label study in hemophilia A patients with residual FVIII levels  $\leq 1$  IU/dL treated continuously with prophylactic exogenous FVIII for a minimum of one year prior to enrollment. Subjects will be enrolled at approximately 60 sites worldwide. Subjects must have high-quality, well-documented historical data available concerning previous bleeding episodes and exogenous FVIII usage over the previous 12 months in order to be eligible to enroll in the study.

Approximately 130 adult subjects with severe HA will receive a 6E13 vg/kg dose of BMN 270 as a single intravenous infusion. Approximately 20 subjects will enroll in the study with at least 12 months of well-documented high-quality historical data concerning previous bleeding episodes and exogenous FVIII usage, while approximately 110 subjects will enroll in the study after having completed approximately 6 months' participation in the BioMarin-sponsored non-interventional study 270-902, in which bleeding and FVIII use data prior to gene therapy will be prospectively collected.

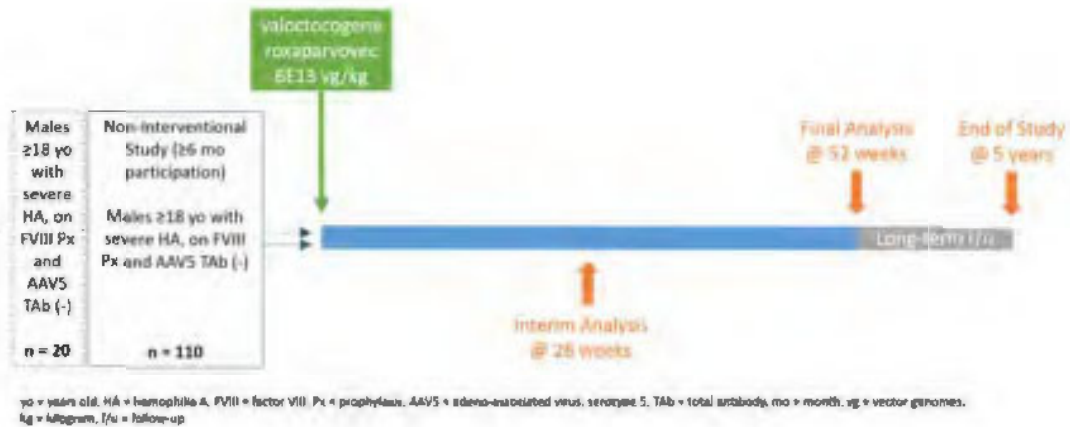

In order to minimize bias in the ongoing study and to assure safe and ethical conduct of the clinical trial, an independent Data Monitoring Committee (DMC), consisting of experts in clinical trials, statistics, and hemophilia, has been convened. The DMC will have sole access during the trial to amalgamated FVIII activity levels, FVIII usage, and bleeding data and will review available safety and efficacy (eg, FVIII activity) data during the study on an ongoing basis; they may determine, based on emerging data and the risk/benefit profile, that further enrollment at 6E13 vg/kg should be discontinued in favor of a different dose of BMN 270, not to exceed 6E13 vg/kg. If the DMC recommends a dosing modification, then additional

subjects may be enrolled, up to a total of approximately 130 subjects, at the new BMN 270 dose level (regardless of the number of subjects previously enrolled at 6E13 vg/kg).

Two interim analyses were planned, after the first approximately 16 and 20 treated HIV-negative subjects, respectively, completed the Week 26 visit (or have discontinued study participation prior to Week 26). The first interim analysis was performed as planned in May 2019. Based on the interim results and the totality of the data, the secondary interim analysis was deemed unnecessary. The DMC reviewed interim analysis results to assess the efficacy and safety profiles, whether the pre-specified criteria of statistical significance has been achieved, and the risk/benefit ratio of the interventions in the BMN 270 studies based on the totality of the data.

The final analysis for the study will be performed after all subjects have been followed for 52 weeks post-BMN 270 infusion. After the final analysis, safety and efficacy will then continue to be assessed long-term in all subjects for a total of approximately 5 years.

To avoid breakthrough bleeding, subjects will only discontinue exogenous prophylactic FVIII replacement therapy after 4 weeks following infusion of BMN 270. Four weeks represents the time by which endogenous production of FVIII following gene transfer is expected to be efficacious, based on earlier results.

As the relationship between activity assay results of the BMN 270 gene product and bleeding remains to be established, Investigators should strive to minimize bias by avoiding consideration of FVIII activity levels by themselves or subjects in the reporting of bleeding episodes and FVIII usage.

In subjects who experience recurrent bleeding episodes, the Investigator and Medical Monitor will discuss whether to resume prior FVIII prophylaxis.

Subjects who do not respond to BMN 270 treatment (ie, treatment failure, manifesting as either failure to achieve FVIII activity  $\geq 5$  IU/dL by Week 52 or inability to maintain independence from prophylactic FVIII replacement therapy due to joint bleeding episodes, in the judgment of the Investigator) may, at the Investigator's discretion and after discussion with the Medical Monitor or Sponsor-designated Data Monitor, follow an abbreviated visit schedule after Week 52 of the study by attending only the Q12W and End of Year visits during Years 2-5. Subjects who are not attending the Q4W/Q6W visits during Years 2-5 may receive a scheduled monthly follow-up telephone call from the site to ask about adverse events, concomitant medications, and bleeding events/FVIII replacement usage.

There will be an ongoing review of individual subject safety by the Medical Monitor, and both safety and efficacy data by the DMC. Therapeutic oral corticosteroids or other



---

immunosuppressive agents may be initiated when a subject's ALT values are elevated, and subsequent dosage adjustments made, after consultation between the Investigator and the Medical Monitor. Management of ALT elevations is discussed in more detail in Section 9.7.8.3.

Any safety signal may trigger a review of the data and possible additional immunogenicity studies or other diagnostics deemed necessary that include an assessment of cellular immune responses using collected peripheral blood mononuclear cells (PBMCs).

An optional liver biopsy will be performed (in subjects who consent to do so) during Year 1 post-infusion, at or around Week 52, and/or during Years 2-5 following BMN 270 infusion. Subjects who consent to the liver biopsy will have additional assessments, including a liver ultrasound and FibroScan, and will receive prophylactic FVIII prior to the procedure, as indicated in the judgment of the Investigator, to minimize the risk of bleeding.

Schedules of assessments for the Screening and Infusion period (Table 9.1.1), Post-Infusion follow-up periods (Table 9.1.2, Table 9.1.3, Table 9.1.4, Table 9.1.5), during the use of oral corticosteroids (Table 9.1.6), and for the optional liver biopsy (Table 9.1.7) are presented below.

**Table 9.1.1: Schedule of Events – Screening and Infusion**

| Assessment  | Prior to BMN 270 Infusion      |  |  | BMN 270 Infusion Visit (Day 1) <sup>k</sup> |
|---|--------------------------------|--|--|---|
|   | Screening* (Day -28 to Day -1) | Smart Rescreening <sup>i</sup> (Day -28 to Day -1) | Baseline (Day -7 to Day -1) <sup>h</sup> |   |
| Informed consent  | X                              |  |  |   |
| Demographics (age, sex, race, ethnicity)  | X                              |  |  |   |
| Medical History   | X                              |  |  |   |
| Physical Examination <sup>a</sup>   | X                              |  | X  | X   |
| Height and Weight   | X                              |  |  |   |
| Vital Signs   | X                              | X  | X  | X   |
| Assessment of Adverse Events and Concomitant Medications  | X                              | X  | X  | X   |
| Documentation of bleeding episodes and FVIII usage for previous 12 months (by either subject or clinical information) | X                              | X  | X  |   |
| Distribution of subject diaries and training in their use <sup>l</sup>  | X                              |  |  |   |
| Electrocardiogram   | X                              |  |  |   |
| Liver Ultrasound  | X                              |  |  |   |
| hFVIII Assays <sup>b</sup>  | X                              | X <sup>i</sup>                                     | X  |   |
| AAV5 TAb Assays <sup>c</sup>  | X                              | X  | X  | X   |
| AAV5 TI Assay   |                                |  | X  |   |
| Screen for Hepatitis B, Hepatitis C, HIV <sup>d</sup>   | X                              |  |  |   |
| Blood chemistry, hematology, and coagulation tests <sup>e</sup>   | X                              | X  | X  |   |
| Fasting lipid panel (blood triglycerides, total cholesterol, HDL cholesterol, and LDL cholesterol)                    |                                |  |  | X   |
| Urine Tests <sup>e</sup>  | X                              | X  | X  |   |
| Liver Tests <sup>e</sup>  | X                              | X  | X  |   |
| PBMC collection (for baseline determination of AAV5 and FVIII specific cellular immunity)                             |                                |  | X  |   |

| Assessment   | Prior to BMN 270 Infusion      |  |  | BMN 270 Infusion Visit (Day 1) <sup>k</sup> |
|--|--------------------------------|--|--|---|
|  | Screening* (Day -28 to Day -1) | Smart Rescreening <sup>i</sup> (Day -28 to Day -1) | Baseline (Day -7 to Day -1) <sup>h</sup> |   |
| Von Willebrand Factor Antigen (VWF:Ag)                       |                                |  | X  |   |
| TGA Assay <sup>g</sup>                                       |                                |  | X  |   |
| PCR of vector DNA in blood, saliva, urine, semen, and stools |                                |  | X  | X   |
| Biomarker testing <sup>f</sup>                               | X                              |  |  |   |
| Exploratory biomarker assessments <sup>g</sup>               |                                |  | X  |   |
| Haemo-QOL-A assessment                                       |                                |  | X  |   |
| EQ-5D-5L   |                                |  | X  |   |
| HAL  |                                |  | X  |   |
| WPAI+CIQ:HS  |                                |  | X  |   |
| PROBE  |                                |  | X  |   |
| BMN 270 Infusion   |                                |  |  | X   |
| Hypersensitivity blood assessments <sup>m</sup>              |                                |  |  | X <sup>m</sup>                              |

\* Screening assessments should be performed within 28 days of BMN 270 infusion (and must be performed within 42 days prior to BMN 270 infusion).

<sup>a</sup> Complete physical examination should be done at Screening. Brief physical examination may be done at Baseline and at the BMN 270 Infusion Visit.

<sup>b</sup> Includes baseline FVIII activity (chromogenic substrate FVIII assay and one-stage clotting FVIII assay), coagulation exploratory assay, hFVIII inhibitor level (Bethesda assay with Nijmegen modification), hFVIII total antibody titer, and hFVIII protein assay. Baseline activity should be assessed at trough (at least >72 hours after last dose of replacement FVIII therapy, or 5x the known half-life of the FVIII concentrates administered).

<sup>c</sup> Sample collection on the day of the infusion visit must be performed before the BMN 270 infusion is given. Screening, Smart Re-screening, and Infusion Day samples will be tested in an AAV5 TAB pre-screening assay specifically developed for enrolment purposes. Baseline and all post-dose samples will be tested in a different AAV5 TAB post-dose immunogenicity monitoring assay

<sup>d</sup> Patients with documented negative results within the last 30 days do not need to be retested. Hepatitis B screening should include hepatitis B surface antigen (HBsAg), hepatitis B surface antibody (HBsAb), and hepatitis B core antibody (HBcAb).

<sup>e</sup> Refer to [Table 9.7.8.2.1](#) for laboratory assessments to be included, and to [Table 9.7.8.3.1](#) for liver tests. ABO blood typing assessment should be performed at Baseline, or at another regularly scheduled visit prior to the end of the subject's participation in the study.

<sup>f</sup> Includes HLA genotyping and FVIII genotyping.

- 
- <sup>g</sup> Blood samples will be collected to evaluate biochemical, molecular, cellular, and genetic/genomic aspects relevant to hemophilia A, coagulation, and/or AAV gene transfer, and to develop assays used for these evaluations. Subjects may choose to opt out of the exploratory genetic/genomic research being done to study or try to discover genes that are not yet known to be associated with hemophilia A. While exploratory samples will be collected at the time points indicated above, testing of these samples (including those for TGA assay and any other exploratory assessments) will be performed only as deemed necessary by the Sponsor.
- <sup>h</sup> Should the screening visit occur within 30 days of the drug infusion, physical examination, blood chemistry, LTs, hematology, urine tests, and coagulation tests do not need to be repeated at Baseline.
- <sup>i</sup> Smart rescreening should only be performed if a patient has been determined to be eligible for the study and is unable to complete the Baseline assessments and Infusion prior to the closing of the original Screening window. Subjects who undergo smart rescreening must complete the rescreening assessments and receive the infusion within 90 days of signing the original consent. Subjects who do not complete dosing within 90 days will be required to re-consent and undergo all screening procedures. Subjects may not undergo smart rescreening more than once.
- <sup>j</sup> Only the hFVIII inhibitor level (Bethesda assay with Nijmegen modification) assay must be done at smart rescreening.
- <sup>k</sup> With the exception of the collection of samples for PCR vector DNA analysis, assessments on the day of infusion must be performed prior to the infusion. Subjects will fast for at least 8 hours prior to pre-infusion laboratory sampling on the day of the infusion visit. On the day of the BMN 270 Infusion, vital signs will be monitored prior to the infusion, during the infusion every 15 minutes ( $\pm$  5 minutes), and following the infusion hourly ( $\pm$  5 minutes) for at least 8 hours during the subject's stay in the clinic. Shedding samples for PCR of vector DNA analysis (blood, saliva, urine, semen, stool) should be collected between 2 and 24 hours after the infusion has been completed.
- <sup>l</sup> Diaries should be distributed to subjects who have consented to participate in the study and who have been determined to meet all study eligibility criteria.
- <sup>m</sup> In case of hypersensitivity or adverse drug reaction, safety assessment, including physical examination and vital signs, will be done and additional blood samples will be collected within 1 hour of the hypersensitivity reaction (eg, tryptase, C3, C3a, C4, C5, C5a, and cytokine bead array, as well as possible additional exploratory testing) and samples for IgE and cytokine bead array (and possible additional exploratory testing) between 8-24 hours after the reaction, if possible. In addition, a blood sample should be taken 1 week after the hypersensitivity reaction for assessment of the cytokine bead array. In-patient observation can be extended and additional blood samples can be collected if deemed necessary at the discretion of the Investigator and Medical Monitor.



**Table 9.1.2: Schedule of Events – Post-Infusion Follow-Up (Week 1-16)**

| Assessment  | Follow-Up After BMN 270 Infusion – Weeks* |    |    |    |    |                |    |                |    |                |    |                 |    |                 |    |                 |     |
|---|---|----|----|----|----|----------------|----|----------------|----|----------------|----|-----------------|----|-----------------|----|-----------------|-----|
|   | Week 1                                    |    | 2  | 3  | 4  | 5 <sup>g</sup> | 6  | 7 <sup>g</sup> | 8  | 9 <sup>g</sup> | 10 | 11 <sup>g</sup> | 12 | 13 <sup>g</sup> | 14 | 15 <sup>g</sup> | 16  |
|   | D4  | D8 |    |    |    |                |    |                |    |                |    |                 |    |                 |    |                 |     |
| Study Day*  | 4   | 8  | 15 | 22 | 29 | 36             | 43 | 50             | 57 | 64             | 71 | 78              | 85 | 92              | 99 | 106             | 113 |
| Physical examination <sup>a</sup>   |   | X  | X  | X  | X  | X <sup>g</sup> | X  | X <sup>g</sup> | X  | X <sup>g</sup> | X  | X <sup>g</sup>  | X  | X <sup>g</sup>  | X  | X <sup>g</sup>  | X   |
| Weight <sup>a</sup>   |   |    |    |    | X  |                |    |                | X  |                |    |                 | X  |                 |    |                 | X   |
| Assessment of Adverse Events and Concomitant Medications (including review of subject diary for bleeding and FVIII use) | X   | X  | X  | X  | X  | X              | X  | X              | X  | X              | X  | X               | X  | X               | X  | X               | X   |
| Vital Signs   |   | X  | X  | X  | X  | X <sup>g</sup> | X  | X <sup>g</sup> | X  | X <sup>g</sup> | X  | X <sup>g</sup>  | X  | X <sup>g</sup>  | X  | X <sup>g</sup>  | X   |
| Blood chemistry, hematology, and coagulation tests <sup>b</sup>   |   |    | X  |    | X  |                |    |                |    |                | X  |                 |    |                 |    |                 | X   |
| Urine Tests <sup>b</sup>  |   |    |    |    |    |                |    |                |    |                |    |                 | X  |                 |    |                 |     |
| Liver Tests <sup>b</sup>  | X   | X  | X  | X  | X  | X              | X  | X              | X  | X              | X  | X               | X  | X               | X  | X               | X   |
| FVIII assays <sup>c</sup>   |   | X  | X  | X  | X  | X              | X  | X              | X  | X              | X  | X               | X  | X               | X  | X               | X   |
| FVIII antibody titer  |   |    |    |    | X  |                |    |                | X  |                |    |                 | X  |                 |    |                 | X   |
| PCR of vector DNA in blood, saliva, urine, semen, and stools <sup>d</sup>   | X   | X  | X  | X  | X  |                | X  |                | X  |                |    |                 | X  |                 |    |                 | X   |
| Exploratory biomarker assessments <sup>e</sup>  |   |    |    |    |    |                | X  |                |    |                |    |                 | X  |                 |    |                 | X   |
| Haemo-QOL-A assessment  |   |    |    |    | X  |                |    |                |    |                |    |                 | X  |                 |    |                 |     |
| EQ-5D-5L  |   |    |    |    | X  |                |    |                |    |                |    |                 | X  |                 |    |                 |     |
| HAL   |   |    |    |    | X  |                |    |                |    |                |    |                 | X  |                 |    |                 |     |



| Assessment  | Follow-Up After BMN 270 Infusion – Weeks* |    |    |    |    |                |    |                |    |                |    |                 |    |                 |    |                 |                |
|---|---|----|----|----|----|----------------|----|----------------|----|----------------|----|-----------------|----|-----------------|----|-----------------|----------------|
|   | Week 1                                    |    | 2  | 3  | 4  | 5 <sup>a</sup> | 6  | 7 <sup>a</sup> | 8  | 9 <sup>a</sup> | 10 | 11 <sup>a</sup> | 12 | 13 <sup>a</sup> | 14 | 15 <sup>a</sup> | 16             |
|   | D4  | D8 |    |    |    |                |    |                |    |                |    |                 |    |                 |    |                 |                |
| Study Day*  | 4   | 8  | 15 | 22 | 29 | 36             | 43 | 50             | 57 | 64             | 71 | 78              | 85 | 92              | 99 | 106             | 113            |
| WPAI+CIQ:HS   |   |    |    |    | X  |                |    |                |    |                |    |                 | X  |                 |    |                 |                |
| PROBE   |   |    |    |    | X  |                |    |                |    |                |    |                 | X  |                 |    |                 |                |
| AAV5 TAb Assay  |   |    |    |    |    |                |    |                | X  |                |    |                 |    |                 |    |                 | X              |
| AAV5 TI Assay   |   |    |    |    |    |                |    |                | X  |                |    |                 |    |                 |    |                 | X              |
| Testing for reactivation of hepatitis B and hepatitis C                 |   |    |    |    |    |                |    |                |    |                |    |                 |    |                 |    |                 | X <sup>f</sup> |
| PBMC collection (for determination of AAV5 and FVIII specific immunity) |   |    | X  |    | X  |                | X  |                | X  |                | X  |                 | X  |                 | X  |                 | X              |
| VWF:Ag  |   |    |    |    |    |                |    |                |    |                |    |                 | X  |                 |    |                 |                |

\* Visit windows are ± 48 hours (and include the Day 4 visit).

<sup>a</sup> Brief physical examination should be done at all weekly visits.

<sup>b</sup> Refer to [Table 9.7.8.2.1](#) for laboratory assessments to be included, and to [Table 9.7.8.3.1](#) for liver tests (LTs). LTs may be monitored more or less frequently (and in particular when ALT values are > ULN or ≥ 1.5x baseline value) based on discussion between the Medical Monitor and the Investigator and review of subject data, but LTs will be monitored at least twice weekly during periods when a subject’s ALT is ≥ 3x ULN. Subjects with ALT > ULN or ≥ 1.5x baseline value during the study and either an alternative etiology considered or for further evaluation of the lab abnormality may undergo additional evaluations (eg, imaging studies including MRI or ultrasound, additional blood tests, and/or liver biopsy) at the discretion of the Investigator. Additional testing of FVIII and LTs during any study week may be performed if: (1) the ALT has increased to above ULN; (2) Increases in ALT values from prior assessment are accompanied by declines in FVIII activity level; or after a discussion between the Medical Monitor and the Investigator based on a review of subject data. If FVIII levels and/or ALT values are stable over the course of several weeks, assessment of FVIII activity and ALT levels may be adjusted based on discussion between the Medical Monitor and the Investigator.

<sup>c</sup> Includes FVIII activity level (chromogenic substrate FVIII assay and one-stage clotting FVIII assay), Bethesda assay (with Nijmegen modification) for hFVIII inhibitor level, coagulation exploratory assay, and hFVIII protein assay. If a subject has used FVIII within 72 hours of a measurement day, all efforts should be made to obtain FVIII activity measurements when a 72-hour interval without FVIII use is achieved; the 72-hour wash-out period is only intended for subjects who have achieved FVIII ≥ 5 IU/dL at 16 weeks after BMN 270 infusion and who have not resumed FVIII replacement therapy. If FVIII levels are elevated or stable over the course of several weeks, assessment of FVIII activity may be adjusted based on discussion between the Medical Monitor and the Investigator. A D-dimer may be considered under circumstances in which FVIII activity levels are above the normal physiological range and/or if there is a concern for a venous thromboembolism.

- 
- <sup>d</sup> Collection for each matrix to occur until at least 3 consecutive results below the limit of detection are obtained. Collection and testing of semen samples must continue at least through Week 12, even if 3 consecutive results below the limit of detection in that compartment have already been recorded.
- <sup>e</sup> Blood samples will be collected to evaluate biochemical, molecular, cellular, and genetic/genomic aspects relevant to hemophilia A, coagulation, and/or AAV gene transfer, and to develop assays used for these evaluations. Subjects may choose to opt out of the exploratory genetic/genomic research being done to study or try to discover genes that are not yet known to be associated with hemophilia A. While exploratory samples will be collected at the time points indicated above, testing of these samples (including those for TGA assay and any other exploratory assessments) will be performed only as deemed necessary by the Sponsor.
- <sup>f</sup> Testing for reactivation of hepatitis B and hepatitis C at Week 16, for subjects with a past medical history of hepatitis B or hepatitis C prior to study entry, should be performed only in subjects who have not received therapeutic oral corticosteroids prior to Week 16; subjects who have received therapeutic oral corticosteroids will have hepatitis B and hepatitis C testing at the time points indicated in [Table 9.1.6](#).
- <sup>g</sup> For subjects who have entered 270-301 following participation in 270-902, the scheduled visits at Week 5, Week 7, Week 9, Week 11, Week 13, and Week 15 may be performed by a mobile nursing (MN) professional at the subject's home or another suitable location (if the subject has given written informed consent to participate in MN visits), or at the site as a shortened lab draw-only visit. The MN service or site will collect blood samples at these visits. For site lab draw-only visits, sites will contact the subject via phone call or e-mail to collect information regarding adverse events, changes to concomitant medications, bleeding episodes, and FVIII use. For MN visits, the service will collect this information. The physical examination and vital signs assessments listed in the Schedule of Events will not be performed at these MN or lab draw-only visits for subjects who have entered 270-301 following participation in 270-902. In the event that neither a lab-only visit or MN visit can be conducted within the visit window, the site should telephone the subject to collect adverse event, concomitant medication, and diary data (bleeding events and FVIII usage).



**Table 9.1.3: Schedule of Events – Post-Infusion Follow-Up (Week 17-32)**

| Assessment  | Follow-Up After BMN 270 Infusion – Weeks* |     |                 |     |                 |     |                 |     |                 |     |                 |     |                 |                 |                 |     |
|---|---|-----|-----------------|-----|-----------------|-----|-----------------|-----|-----------------|-----|-----------------|-----|-----------------|-----------------|-----------------|-----|
|   | 17 <sup>f</sup>                           | 18  | 19 <sup>f</sup> | 20  | 21 <sup>f</sup> | 22  | 23 <sup>f</sup> | 24  | 25 <sup>f</sup> | 26  | 27 <sup>f</sup> | 28  | 29 <sup>f</sup> | 30 <sup>f</sup> | 31 <sup>f</sup> | 32  |
| Study Day*  | 120                                       | 127 | 134             | 141 | 148             | 155 | 162             | 169 | 176             | 183 | 190             | 197 | 204             | 211             | 218             | 225 |
| Physical examination <sup>a</sup>   | X <sup>f</sup>                            | X   | X <sup>f</sup>  | X   | X <sup>f</sup>  | X   | X <sup>f</sup>  | X   | X <sup>f</sup>  | X   | X <sup>f</sup>  | X   | X <sup>f</sup>  | X <sup>f</sup>  | X <sup>f</sup>  | X   |
| Weight <sup>a</sup>   |   |     |                 | X   |                 |     |                 | X   |                 |     |                 | X   |                 |                 |                 | X   |
| Assessment of Adverse Events and Concomitant Medications (including review of subject diary for bleeding and FVIII use) | X   | X   | X               | X   | X               | X   | X               | X   | X               | X   | X               | X   | X               | X               | X               | X   |
| Vital Signs   | X <sup>f</sup>                            | X   | X <sup>f</sup>  | X   | X <sup>f</sup>  | X   | X <sup>f</sup>  | X   | X <sup>f</sup>  | X   | X <sup>f</sup>  | X   | X <sup>f</sup>  | X <sup>f</sup>  | X <sup>f</sup>  | X   |
| Blood chemistry, hematology, and coagulation tests <sup>b</sup>   |   |     |                 |     |                 | X   |                 |     |                 | X   |                 |     |                 |                 |                 | X   |
| Urine Tests <sup>b</sup>  |   |     |                 |     |                 |     |                 |     |                 | X   |                 |     |                 |                 |                 |     |
| Liver Tests <sup>b</sup>  | X   | X   | X               | X   | X               | X   | X               | X   | X               | X   | X               | X   | X               | X               | X               | X   |
| FVIII assays <sup>c</sup>   | X   | X   | X               | X   | X               | X   | X               | X   | X               | X   | X               | X   | X               | X               | X               | X   |
| FVIII antibody titer  |   |     |                 | X   |                 |     |                 | X   |                 | X   |                 |     |                 |                 |                 | X   |
| PCR of vector DNA in blood, saliva, urine, semen, and stools <sup>d</sup>   |   |     |                 | X   |                 |     |                 | X   |                 | X   |                 |     |                 |                 |                 | X   |
| Exploratory biomarker assessments <sup>e</sup>  |   |     |                 | X   |                 |     |                 | X   |                 | X   |                 |     |                 |                 |                 | X   |





| Assessment   | Follow-Up After BMN 270 Infusion – Weeks* |     |                 |     |                 |     |                 |     |                 |     |                 |     |                 |                 |                 |     |
|--|---|-----|-----------------|-----|-----------------|-----|-----------------|-----|-----------------|-----|-----------------|-----|-----------------|-----------------|-----------------|-----|
|  | 17 <sup>f</sup>                           | 18  | 19 <sup>f</sup> | 20  | 21 <sup>f</sup> | 22  | 23 <sup>f</sup> | 24  | 25 <sup>f</sup> | 26  | 27 <sup>f</sup> | 28  | 29 <sup>f</sup> | 30 <sup>f</sup> | 31 <sup>f</sup> | 32  |
| Study Day*   | 120                                       | 127 | 134             | 141 | 148             | 155 | 162             | 169 | 176             | 183 | 190             | 197 | 204             | 211             | 218             | 225 |
| Haemo-QOL-A assessment   |   |     |                 |     |                 |     |                 |     |                 | X   |                 |     |                 |                 |                 |     |
| EQ-5D-5L   |   |     |                 |     |                 |     |                 |     |                 | X   |                 |     |                 |                 |                 |     |
| HAL  |   |     |                 |     |                 |     |                 |     |                 | X   |                 |     |                 |                 |                 |     |
| WPAI+CIQ:HS  |   |     |                 |     |                 |     |                 |     |                 | X   |                 |     |                 |                 |                 |     |
| PROBE  |   |     |                 |     |                 |     |                 |     |                 | X   |                 |     |                 |                 |                 |     |
| AAV5 TAb Assay   |   |     |                 |     |                 |     |                 | X   |                 |     |                 |     |                 |                 |                 | X   |
| AAV5 TI Assay  |   |     |                 |     |                 |     |                 | X   |                 |     |                 |     |                 |                 |                 | X   |
| PBMC collection (for determination of AAV5 and FVIII specific cellular immunity) |   | X   |                 | X   |                 | X   |                 | X   |                 | X   |                 | X   |                 |                 |                 | X   |
| VWF:Ag   |   |     |                 |     |                 |     |                 |     |                 | X   |                 |     |                 |                 |                 |     |
| TGA Assay <sup>c</sup>   |   |     |                 | X   |                 |     |                 | X   |                 | X   |                 |     |                 |                 |                 | X   |
| Optional liver biopsy <sup>g</sup>   | Perform during Year 1                     |     |                 |     |                 |     |                 |     |                 |     |                 |     |                 |                 |                 |     |

\* Visit windows are ± 48 hours.

<sup>a</sup> Brief physical examination should be done at all weekly visits except Week 26, where a complete physical examination should be performed. Weight should be recorded at Week 20 and every 4 weeks.

<sup>b</sup> Refer to [Table 9.7.8.2.1](#) for laboratory assessments to be included, and to [Table 9.7.8.3.1](#) for liver tests (LTs). LTs may be monitored more or less frequently (and in particular when ALT values are > ULN or ≥ 1.5x baseline value) based on discussion between the Medical Monitor and the Investigator and review of subject data, but LTs will be monitored at least twice weekly during periods when a subject’s ALT is ≥ 3x ULN. Subjects with ALT > ULN or ≥ 1.5x baseline value during the study and either an alternative etiology considered or for further evaluation of the lab abnormality may undergo additional evaluations (eg, imaging studies including MRI or ultrasound, additional blood tests, and/or liver biopsy) at the discretion of the Investigator. Additional testing of FVIII and LTs during any study week may be performed if: (1) the ALT has increased to above ULN; (2) Increases in ALT values from prior assessment are accompanied by declines in FVIII activity level; or after a discussion between the Medical Monitor and the Investigator based on a review of subject data. If FVIII levels and/or ALT values are stable over the course of several weeks, assessment of FVIII activity and ALT levels may be adjusted based on discussion between the Medical Monitor and the Investigator.

- <sup>c</sup> Includes FVIII activity level (chromogenic substrate FVIII assay and one-stage clotting FVIII assay), Bethesda assay (with Nijmegen modification) for hFVIII inhibitor level, coagulation exploratory assay, and hFVIII protein. If a subject has used FVIII within 72 hours of a measurement day, all efforts should be made to obtain FVIII activity measurements when a 72-hour interval without FVIII use is achieved; the 72-hour wash-out period is only intended for subjects who have achieved FVIII  $\geq 5$  IU/dL at 16 weeks after BMN 270 infusion and who have not resumed FVIII replacement therapy. If FVIII levels are elevated or stable over the course of several weeks, assessment of FVIII activity may be adjusted based on discussion between the Medical Monitor and the Investigator. A D-dimer may be considered under circumstances in which FVIII activity levels are above the normal physiological range and/or if there is a concern for a venous thromboembolism.
- <sup>d</sup> Collection for each matrix to occur until at least 3 consecutive results below the limit of detection are obtained.
- <sup>e</sup> Blood samples will be collected to evaluate biochemical, molecular, cellular, and genetic/genomic aspects relevant to hemophilia A, coagulation, and/or AAV gene transfer, and to develop assays used for these evaluations. Subjects may choose to opt out of the exploratory genetic/genomic research being done to study or try to discover genes that are not yet known to be associated with hemophilia A. While exploratory samples will be collected at the time points indicated above, testing of these samples (including those for TGA assay and any other exploratory assessments) will be performed only as deemed necessary by the Sponsor.
- <sup>f</sup> For subjects who have entered 270-301 following participation in 270-902, the scheduled visits at Week 17, Week 19, Week 21, Week 23, Week 25, Week 27, Week 29, Week 30, and Week 31 may be performed by a mobile nursing (MN) professional at the subject's home or another suitable location (if the subject has given written informed consent to participate in MN visits), or at the site as a shortened lab draw-only visit. The MN service or site will collect blood samples at these visits. For site lab draw-only visits, sites will contact the subject via phone call or e-mail to collect information regarding adverse events, changes to concomitant medications, bleeding episodes, and FVIII use. For MN visits, the service will collect this information. The physical examination and vital signs assessments listed in the Schedule of Events will not be performed at these MN or lab draw-only visits for subjects who have entered 270-301 following participation in 270-902. In the event that neither a lab-only visit or MN visit can be conducted within the visit window, the site should telephone the subject to collect adverse event, concomitant medication, and diary data (bleeding events and FVIII usage).
- <sup>g</sup> Subjects who elect to proceed will have a liver biopsy performed during Year 1 post-infusion. Additional liver biopsies at times deemed to be clinically relevant (eg, decreasing FVIII at a time of increased ALT) may be pursued. Subjects will be asked to consent to the procedure for each liver biopsy performed during the study. Subjects should fast for at least 8 hours prior to liver ultrasound and optional liver biopsies.

**Table 9.1.4: Schedule of Events – Post-Infusion Follow-Up (Week 33 – Week 52)**

| Assessment  | Year 1 – Weeks* |                 |                 |     |                 |     |                 |     |                 |     |                 |     |
|---|-----------------|-----------------|-----------------|-----|-----------------|-----|-----------------|-----|-----------------|-----|-----------------|-----|
|   | 33 <sup>f</sup> | 34 <sup>e</sup> | 35 <sup>f</sup> | 36  | 38 <sup>f</sup> | 40  | 42 <sup>f</sup> | 44  | 46 <sup>f</sup> | 48  | 50 <sup>f</sup> | 52  |
| Study Day*  | 232             | 239             | 246             | 253 | 267             | 281 | 295             | 309 | 323             | 337 | 351             | 365 |
| Physical examination <sup>a</sup>   | X <sup>f</sup>  | X <sup>f</sup>  | X <sup>f</sup>  | X   | X <sup>f</sup>  | X   | X <sup>f</sup>  | X   | X <sup>f</sup>  | X   | X <sup>f</sup>  | X   |
| Weight <sup>a</sup>   |                 |                 |                 | X   |                 | X   |                 | X   |                 | X   |                 | X   |
| Assessment of Adverse Events and Concomitant Medications (including review of subject diary for bleeding and FVIII use) | X               | X               | X               | X   | X               | X   | X               | X   | X               | X   | X               | X   |
| Vital Signs   | X <sup>f</sup>  | X <sup>f</sup>  | X <sup>f</sup>  | X   | X <sup>f</sup>  | X   | X <sup>f</sup>  | X   | X <sup>f</sup>  | X   | X <sup>f</sup>  | X   |
| Blood chemistry, hematology, and coagulation tests <sup>b</sup>   |                 |                 |                 | X   |                 |     |                 | X   |                 |     |                 | X   |
| Urine Tests <sup>b</sup>  |                 |                 |                 | X   |                 |     |                 |     |                 |     |                 | X   |
| Liver Tests <sup>b</sup>  | X               | X               | X               | X   | X               | X   | X               | X   | X               | X   | X               | X   |
| FVIII assays <sup>c</sup>   | X               | X               | X               | X   | X               | X   | X               | X   | X               | X   | X               | X   |
| AAV5 TAb Assay  |                 |                 |                 | X   |                 |     |                 |     |                 |     |                 | X   |
| AAV5 TI Assay   |                 |                 |                 | X   |                 |     |                 |     |                 |     |                 | X   |
| FVIII antibody titer  |                 |                 |                 | X   |                 |     |                 | X   |                 |     |                 | X   |
| Exploratory biomarker assessments <sup>d</sup>  |                 |                 |                 | X   |                 | X   |                 | X   |                 | X   |                 | X   |
| PBMC Collection (for determination of FVIII and Capsid specific cellular immunity)                                      |                 |                 |                 | X   |                 |     |                 | X   |                 |     |                 | X   |
| VWF:Ag  |                 |                 |                 | X   |                 |     |                 |     |                 |     |                 | X   |
| TGA Assay <sup>d</sup>  |                 |                 |                 | X   |                 | X   |                 | X   |                 | X   |                 | X   |
| PCR of vector DNA in blood, saliva, urine, semen, and stools <sup>e</sup>   |                 |                 |                 | X   |                 | X   |                 | X   |                 | X   |                 | X   |
| Haemo-QOL-A assessment  |                 |                 |                 |     |                 |     |                 |     |                 |     |                 | X   |
| EQ-5D-5L  |                 |                 |                 |     |                 |     |                 |     |                 |     |                 | X   |
| HAL   |                 |                 |                 |     |                 |     |                 |     |                 |     |                 | X   |
| WPAI+CIQ:HS   |                 |                 |                 |     |                 |     |                 |     |                 |     |                 | X   |



| Assessment                         | Year 1 – Weeks*       |                 |                 |    |                 |    |                 |    |                 |    |                 |    |
|------------------------------------|-----------------------|-----------------|-----------------|----|-----------------|----|-----------------|----|-----------------|----|-----------------|----|
|                                    | 33 <sup>f</sup>       | 34 <sup>e</sup> | 35 <sup>f</sup> | 36 | 38 <sup>f</sup> | 40 | 42 <sup>f</sup> | 44 | 46 <sup>f</sup> | 48 | 50 <sup>f</sup> | 52 |
| PROBE                              |                       |                 |                 |    |                 |    |                 |    |                 |    |                 | X  |
| Optional liver biopsy <sup>g</sup> | Perform during Year 1 |                 |                 |    |                 |    |                 |    |                 |    |                 | X  |

\* Visit windows are ± 48 hours through Week 36, then ±1 week until Week 52

<sup>a</sup> Complete physical examination should be performed at Week 52; brief physical exam may be performed at other study visits. Weight should be recorded at Week 36 and every 4 weeks through Week 52.

<sup>b</sup> Refer to [Table 9.7.8.2.1](#) for laboratory assessments to be included, and to [Table 9.7.8.3.1](#) for liver tests. LTs may be monitored more or less frequently (and in particular when ALT values are > ULN or ≥ 1.5x baseline value) based on discussion between the Medical Monitor and the Investigator and review of subject data, but LTs will be monitored at least twice weekly during periods when a subject’s ALT is ≥ 3x ULN. Subjects with ALT > ULN or ≥ 1.5x baseline value during the study and either an alternative etiology considered or for further evaluation of the lab abnormality may undergo additional evaluations (eg, imaging studies including MRI or ultrasound, additional blood tests, and/or liver biopsy) at the discretion of the Investigator. Additional testing of FVIII and LTs during any study week may be performed if: (1) the ALT has increased to above ULN or increased by > 10 U/L from prior assessment; (2) Increases in ALT values from prior assessment are accompanied by declines in FVIII activity level; or after a discussion between the Medical Monitor and the Investigator based on a review of subject data. If FVIII levels and/or ALT values are stable over the course of several weeks, assessment of FVIII activity and ALT levels may be adjusted based on discussion between the Medical Monitor and the Investigator.

<sup>c</sup> Includes FVIII activity level (chromogenic substrate FVIII assay and one-stage clotting FVIII assay), Bethesda assay (with Nijmegen modification) for hFVIII inhibitor level, coagulation exploratory assay, and hFVIII protein assay. If a subject has used FVIII within 72 hours of a measurement day, all efforts should be made to obtain FVIII activity measurements when a 72-hour interval without FVIII use is achieved; the 72-hour wash-out period is only intended for subjects who have achieved FVIII ≥ 5 IU/dL at 16 weeks after BMN 270 infusion and who have not resumed FVIII replacement therapy. If FVIII levels are elevated or stable over the course of several weeks, assessment of FVIII activity may be adjusted based on discussion between the Medical Monitor and the Investigator. A D-dimer may be considered under circumstances in which FVIII activity levels are above the normal physiological range and/or if there is a concern for a venous thromboembolism.

<sup>d</sup> Blood samples will be collected to evaluate biochemical, molecular, cellular, and genetic/genomic aspects relevant to hemophilia A, coagulation, and/or AAV gene transfer, and to develop assays used for these evaluations. Subjects may choose to opt out of the exploratory genetic/genomic research being done to study or try to discover genes that are not yet known to be associated with hemophilia A. While exploratory samples will be collected at the time points indicated above, testing of these samples (including those for TGA assay and any other exploratory assessments) will be performed only as deemed necessary by the Sponsor.

<sup>e</sup> Collection for each matrix to occur until at least 3 consecutive results below the limit of detection are obtained.

<sup>f</sup> For subjects who have entered 270-301 following participation in 270-902, the scheduled visits at Week 33, Week 34, Week 35, Week 38, Week 42, Week 46, and Week 50 may be performed by a mobile nursing (MN) professional at the subject’s home or another suitable location (if the subject has given written informed consent to participate in MN visits), or at the site as a shortened lab draw-only visit. The MN service or site will collect blood samples at these visits. For site lab draw-only visits, sites will contact the subject via phone call or e-mail to collect information regarding adverse events, changes to concomitant medications, bleeding episodes, and FVIII use. For MN visits, the service will collect this information. The physical examination and vital signs assessments listed in the Schedule of Events will not be performed at these MN or lab draw-only visits for subjects who have entered 270-301

---

following participation in 270-902. In the event that neither a lab-only visit or MN visit can be conducted within the visit window, the site should telephone the subject to collect adverse event, concomitant medication, and diary data (bleeding events and FVIII usage).

<sup>g</sup> Subjects who elect to proceed will have a liver biopsy performed during Year 1 post-infusion, at or around Week 52. Additional liver biopsies at times deemed to be clinically relevant (eg decreasing FVIII at a time of increased ALT) may be pursued. Subjects will be asked to consent to the procedure for each liver biopsy performed during the study. Subjects should fast for at least 8 hours prior to liver ultrasound and optional liver biopsies.



**Table 9.1.5: Schedule of Events – Post-Infusion Follow-Up (Year 2 – Year 5)**

| Assessment  | Years 2-5*       | Year 2*          | Years 3-5*       | End of Year Visit |                |                |                | ETV              |
|---|------------------|------------------|------------------|-------------------|----------------|----------------|----------------|------------------|
|   | Q12W             | Q4W <sup>g</sup> | Q6W <sup>g</sup> | Year 2<br>W104    | Year 3<br>W156 | Year 4<br>W208 | Year 5<br>W260 |                  |
| Study Week*   |                  |                  |                  |                   |                |                |                |                  |
| Physical examination <sup>a</sup>   | X <sup>a</sup>   |                  |                  | X <sup>a</sup>    |                |                |                | X                |
| Weight <sup>a</sup>   | X <sup>a</sup>   |                  |                  | X <sup>a</sup>    |                |                |                | X                |
| Assessment of Adverse Events and Concomitant Medications (including review of subject diary for bleeding and FVIII use) | X                | X                | X                | X                 |                |                |                | X                |
| Vital Signs   | X                |                  |                  | X                 |                |                |                | X                |
| Blood chemistry, hematology, and coagulation tests <sup>b</sup>   | X <sup>b</sup>   |                  |                  | X <sup>b</sup>    |                |                |                | X                |
| Urine Tests <sup>b</sup>  | X <sup>b</sup>   |                  |                  | X <sup>b</sup>    |                |                |                | X                |
| Liver Tests <sup>b</sup>  | X                | X                | X                | X                 |                |                |                | X                |
| FVIII assays <sup>c</sup>   | X                | X                | X                | X                 |                |                |                | X                |
| AAV5 TAb Assay  | X                |                  |                  | X                 |                |                |                | X                |
| AAV5 TI Assay   | X                |                  |                  | X                 |                |                |                | X                |
| FVIII antibody titer  | X                |                  |                  | X                 |                |                |                | X                |
| Exploratory biomarker assessments <sup>e</sup>  | X                |                  |                  | X                 |                |                |                | X                |
| PBMC Collection (for determination of FVIII and Capsid specific cellular immunity)                                      | X                |                  |                  | X                 |                |                |                | X                |
| VWF:Ag  | X                |                  |                  | X                 |                |                |                | X                |
| TGA Assay <sup>c</sup>  | X                |                  |                  | X                 |                |                |                | X                |
| PCR of vector DNA in semen <sup>d</sup>   | (X) <sup>d</sup> | (X) <sup>d</sup> | (X) <sup>d</sup> | (X) <sup>d</sup>  |                |                |                | (X) <sup>d</sup> |
| PCR of vector DNA in blood, saliva, urine, and stools <sup>d</sup>  | (X) <sup>d</sup> |                  |                  | (X) <sup>d</sup>  |                |                |                | (X) <sup>d</sup> |
| Haemo-QOL-A assessment  | X <sup>f</sup>   |                  |                  | X <sup>f</sup>    |                |                |                | X                |
| EQ-5D-5L  | X <sup>f</sup>   |                  |                  | X <sup>f</sup>    |                |                |                | X                |
| HAL   | X <sup>f</sup>   |                  |                  | X <sup>f</sup>    |                |                |                | X                |



| Assessment                         | Years 2-5*     | Year 2*          | Years 3-5*       | End of Year Visit |                |                |                | ETV |
|------------------------------------|----------------|------------------|------------------|-------------------|----------------|----------------|----------------|-----|
|                                    | Q12W           | Q4W <sup>g</sup> | Q6W <sup>g</sup> | Year 2<br>W104    | Year 3<br>W156 | Year 4<br>W208 | Year 5<br>W260 |     |
| Study Week*                        |                |                  |                  |                   |                |                |                |     |
| WPAI+CIQ:HS                        | X <sup>f</sup> |                  |                  |                   | X <sup>f</sup> |                |                | X   |
| PROBE                              | X <sup>f</sup> |                  |                  |                   | X <sup>f</sup> |                |                | X   |
| Optional liver biopsy <sup>h</sup> |                |                  |                  |                   | X              |                |                |     |

\* Visit windows are ± 2 weeks for visits in Years 2-5. At applicable sites, the Q4W (during Year 2) and Q6W (during Years 3-5) assessments may be conducted by a trained mobile nursing (MN) professional at the subject’s home or another suitable location, if the subject has given written informed consent to participate in mobile nursing visits. Q12W and End of Year visits during Years 2-5 cannot be done by a MN professional and must be done at the study site.

<sup>a</sup> Complete physical examination should be performed at the End of Year visits; brief physical exam may be performed at other study visits. Weight should be recorded at the second Q12W visit each year and at every End of Year visit during Years 2-5.

<sup>b</sup> Refer to [Table 9.7.8.2.1](#) for laboratory assessments to be included, and to [Table 9.7.8.3.1](#) for liver tests. LTs may be monitored more or less frequently (and in particular when ALT values are > ULN or ≥ 1.5x baseline value) based on discussion between the Medical Monitor and the Investigator and review of subject data, but LTs will be monitored at least twice weekly during periods when a subject’s ALT is ≥ 3x ULN. Subjects with ALT > ULN or ≥ 1.5x baseline value during the study and either an alternative etiology considered or for further evaluation of the lab abnormality may undergo additional evaluations (eg, imaging studies including MRI or ultrasound, additional blood tests, and/or liver biopsy) at the discretion of the Investigator. Additional testing of FVIII and LTs during any study week may be performed if: (1) the ALT has increased to above ULN or increased by > 10 U/L from prior assessment; (2) Increases in ALT values from prior assessment are accompanied by declines in FVIII activity level; or after a discussion between the Medical Monitor and the Investigator based on a review of subject data. If FVIII levels and/or ALT values are stable over the course of several weeks, assessment of FVIII activity and ALT levels may be adjusted based on discussion between the Medical Monitor and the Investigator. During Years 2-5 of the Post-Infusion Follow-Up period, urine tests and blood, chemistry, and coagulation tests should be performed at the second Q12W visit each year and at every End of Year visit.

<sup>c</sup> Includes FVIII activity level (chromogenic substrate FVIII assay and one-stage clotting FVIII assay), Bethesda assay (with Nijmegen modification) for hFVIII inhibitor level, coagulation exploratory assay, and hFVIII protein assay. If a subject has used FVIII within 72 hours of a measurement day, all efforts should be made to obtain FVIII activity measurements when a 72-hour interval without FVIII use is achieved; the 72-hour wash-out period is only intended for subjects who have achieved FVIII ≥ 5 IU/dL at 16 weeks after BMN 270 infusion and who have not resumed FVIII replacement therapy. If FVIII levels are elevated or stable over the course of several weeks, assessment of FVIII activity may be adjusted based on discussion between the Medical Monitor and the Investigator. A D-dimer may be considered under circumstances in which FVIII activity levels are above the normal physiological range and/or if there is a concern for a venous thromboembolism. If a subject tests positive in the Bethesda assay (with Nijmegen modification) during Years 3-5, a fresh sample should be collected within 4 weeks of the initial visit that had a positive result.

<sup>d</sup> Sample testing during Long-Term Follow-Up is not required if at least 3 consecutive samples were below the limit of detection during the Post-Infusion Follow-Up period. Subjects who have not had 3 consecutive semen samples below the limit of detection by Week 52 should continue to have PCR testing of semen every 4 weeks (during Year 2) or every 6 weeks (during Years 3-5) until 3 consecutive samples below the limit of detection are documented (or upon consultation between the Investigator and Medical Monitor).



- 
- <sup>e</sup> Blood samples will be collected to evaluate biochemical, molecular, cellular, and genetic/genomic aspects relevant to hemophilia A, coagulation, and/or AAV gene transfer, and to develop assays used for these evaluations. Subjects may choose to opt out of the exploratory genetic/genomic research being done to study or try to discover genes that are not yet known to be associated with hemophilia A. While exploratory samples will be collected at the time points indicated above, testing of these samples (including those for TGA assay and any other exploratory assessments) will be performed only as deemed necessary by the Sponsor.
- <sup>f</sup> PRO assessments during Years 2-5 of Long-Term Follow-up should be performed at the second Q12W visit each year and at every End of Year visit.
- <sup>g</sup> Subjects who meet the definition of treatment failure to BMN 270 therapy after Week 52 may omit the Q4W and Q6W visits during Years 2-5, and must attend only the Q12W and End of Year visits. Subjects who are not attending the Q4W/Q6W visits during Years 2-5 may receive a scheduled monthly follow-up telephone call from the site to ask about adverse events, concomitant medications, and bleeding events/FVIII replacement usage. Such subjects following the abbreviated schedule who have not yet cleared vector shedding in one or more matrices must still provide samples in the uncleared matrix Q4W (during Year 2) or Q6W (during Years 3-5) until vector shedding has been cleared, either by reporting to the site to provide samples or by providing those samples to a MN professional.
- <sup>h</sup> An optional liver biopsy may be performed at any time between Years 2-5 of the study. The optional biopsy may be triggered by a FVIII activity decline by > 50% from steady-state, over 2 consecutive measurements, or by a sustained ALT rise > ULN. If neither triggered is observed, the optional biopsy may be performed at the end of Year 5. Subjects should fast for at least 8 hours prior to liver ultrasound and optional liver biopsies.



**Table 9.1.6: Schedule of Events – Therapeutic Corticosteroids for ALT Elevations**

|   | Steroid Treatment Period <sup>b</sup> |        |        |        |        |        |        |                     | Post-Steroid Period <sup>c</sup> |        |        |        |         |
|---|---------------------------------------|--------|--------|--------|--------|--------|--------|---------------------|----------------------------------|--------|--------|--------|---------|
|   | Week 1                                | Week 2 | Week 3 | Week 4 | Week 5 | Week 6 | Week 7 | Week 8 <sup>b</sup> | Week 1                           | Week 2 | Week 3 | Week 4 | Week 13 |
| Therapeutic corticosteroids (dose in mg/day) <sup>a</sup> | 60 mg                                 | 60 mg  | 40 mg  | 40 mg  | 40 mg  | 30 mg  | 20 mg  | 10 mg               |                                  |        |        |        |         |
| FVIII activity testing                                    |                                       |        |        |        |        |        |        |                     | X                                | X      | X      | X      |         |
| Liver tests   |                                       |        |        |        |        |        |        |                     | X                                | X      | X      | X      |         |
| Hepatitis B testing <sup>d</sup>                          |                                       |        |        |        |        | X      |        |                     | X                                |        |        |        | X       |
| HCV Viral Load <sup>d</sup>                               |                                       |        |        |        |        | X      |        |                     | X                                |        |        |        | X       |

<sup>a</sup> Therapeutic oral corticosteroids may be initiated according to the parameters set out in Section 9.4.8.2.

<sup>b</sup> Following initiation or completion of steroid regimen, if a recurrence of ALT values > ULN or  $\geq 1.5x$  baseline value is reported, steroid management decisions will be based on discussions between the Investigator and Medical Monitor. Modification of the steroid regimen may take into consideration possible confounders for the ALT elevation, relationship between increases in ALT and FVIII activity, ALT/FVIII levels post steroid initiation, and adverse events related to steroid dosing. Guidance for tapering oral corticosteroid dosing can be found in Section 9.4.8.2.

<sup>c</sup> After discontinuation of oral corticosteroids, weekly labs for ALT and FVIII levels will be measured once a week for 4 weeks to ensure stability in values. If these assessments are already being done as part of normal study follow-up, they do not need to be duplicated.

<sup>d</sup> Should only be performed in subjects with a history of hepatitis B or hepatitis C prior to study entry.



**Table 9.1.7: Schedule of Events – Optional Liver Biopsy**

|   | <b>Within 28 Days Before Biopsy Day</b> | <b>Within 7 Days Before Biopsy Day</b> | <b>Biopsy Day (BD)</b> |
|---|---|--|------------------------|
| Informed Consent for Liver Biopsy Procedure                 | X                                       |  |                        |
| Liver Ultrasound <sup>a</sup>                               | X                                       |  |                        |
| Physical examination  | X                                       |  | X                      |
| Hematology, Coagulation, Chemistry Assessments <sup>b</sup> | X                                       |  | X                      |
| Liver Tests <sup>b</sup>                                    | X                                       |  | X                      |
| FibroScan   | X                                       |  |                        |
| FVIII Activity Level Assessment (central and local)         |   | X                                      | X*                     |
| Exploratory CK18 and Grp78 assessment                       |   | X                                      | X*                     |
| Pre-Biopsy Consultation <sup>c</sup>                        |   | X                                      |                        |
| Liver Biopsy <sup>d</sup>                                   |   |  | X                      |
| PBMC Collection (whole blood draw)                          |   |  | X <sup>e</sup>         |

If Day -28 assessments are already performed as part of a scheduled on-site study visit, they do not need to be duplicated here.

\* If the Day -7 and biopsy day visits occur on the same day, these tests do not need to be duplicated.

<sup>a</sup> Liver ultrasound must be performed within 28 days prior to the scheduled biopsy. Subjects should fast for at least 8 hours prior to liver ultrasound.

<sup>b</sup> Refer to [Table 9.7.8.2.1](#) for laboratory assessments to be included, and to [Table 9.7.8.3.1](#) for liver tests.

<sup>c</sup> Subjects will undergo a pre-biopsy consultation with the Investigator (treating hematologist) and hepatologist and/or radiologist.

<sup>d</sup> Subjects should fast for at least 8 hours prior to optional liver biopsy. Biopsy will be a percutaneous or transjugular biopsy under ultrasound guidance, performed according to the standard procedure of the institution. If only a small amount of tissue (< 2 cm) is obtained at the time of the biopsy, the subject may be asked to consent for a second pass. In this case, the original < 2 cm sample should still be retained and handled according to the instructions for handling biopsy specimens in the Laboratory Manual. Following completion of the biopsy, the subject should remain in the hospital under observation for at least 4-6 hours. Overnight post-procedure observation may be done at the investigator’s discretion.

<sup>e</sup> Blood draw for PBMC collection should be performed on the biopsy day or ± 1 week from the biopsy day.

## 9.2 Discussion of Study Design, Including Choice of Control Group

Study 270-301 is designed to be a Phase 3, single-arm, open-label study in hemophilia A patients with residual FVIII levels  $\leq 1$  IU/dL previously treated with prophylactic exogenous FVIII. Hemophilia A patients who provide written informed consent, meet the entry criteria definition of residual FVIII activity, have well-documented historical data for the previous 12 months concerning exogenous FVIII usage and bleeding episodes, and do not have antibodies to AAV5 will be eligible to enroll in the study.

Approximately 130 subjects will be enrolled at the 6E13 vg/kg BMN 270 dose. Subjects will be followed for 52 weeks post-BMN 270 infusion during which safety and efficacy assessments will be taken. After the final analysis at 52 weeks post-infusion, safety and efficacy will then continue to be assessed long-term for approximately a total of 5 years. During enrollment, the DMC will review available safety and efficacy data on an ongoing basis and may decide to recommend dosing subjects at a different dose level (not to exceed 6E13 vg/kg) based on emerging data from 270-301 and their overall benefit:risk assessment.

Study 270-301 is a self-controlled study. Parameters for each subject will be compared to a pre-treatment assessment of safety (liver function) and efficacy (number of bleeds, use of FVIII replacement therapy).

## 9.3 Selection of Study Population

Approximately 130 adult hemophilia A patients with residual FVIII levels  $\leq 1$  IU/dL may enroll into the study.

Additional criteria for participation in the study are provided in Section 9.3.1 and Section 9.3.2.

### 9.3.1 Inclusion Criteria

Individuals eligible to participate in this study must meet all of the following inclusion criteria:

1. Males  $\geq 18$  years of age with hemophilia A and residual FVIII levels  $\leq 1$  IU/dL as evidenced by medical history, at the time of signing the informed consent.
2. Must have been on prophylactic FVIII replacement therapy for at least 12 months prior to study entry. High-quality, well-documented historical data concerning bleeding episodes and FVIII usage over the previous 12 months must be available.
3. Treated/exposed to FVIII concentrates or cryoprecipitate for a minimum of 150 exposure days (EDs).

4. Willing and able to provide written, signed informed consent after the nature of the study has been explained and prior to any study-related procedures.
5. No previous documented history of a detectable FVIII inhibitor, and results from a Bethesda assay or Bethesda assay with Nijmegen modification of less than 0.6 Bethesda Units (BU) (or less than 1.0 BU for laboratories with a historical lower sensitivity cutoff for inhibitor detection of 1.0 BU) on 2 consecutive occasions at least one week apart within the past 12 months (at least one of which should be tested at the central laboratory).
6. Sexually active participants must agree to use an acceptable method of effective contraception, either double-barrier contraception (ie, condom + diaphragm; or condom or diaphragm + spermicidal gel or foam) or their female partner either using hormonal contraceptives or having an intrauterine device. Participants must agree to contraception use for at least 12 weeks post-infusion; after 12 weeks, subjects may stop contraception use only if they have had 3 consecutive semen samples with viral vector DNA below the limit of detection.
7. Willing to abstain from alcohol consumption for at least the first 52 weeks following BMN 270 infusion.

### 9.3.2 Exclusion Criteria

Individuals who meet any of the following exclusion criteria will not be eligible to participate in the study:

1. Detectable pre-existing antibodies to the AAV5 capsid.
2. Any evidence of active infection or any immunosuppressive disorder, including HIV infection.
3. Significant liver dysfunction with any of the following abnormal laboratory results:
  - ALT (alanine aminotransferase) > 1.25x ULN;
  - AST (aspartate aminotransferase) > 1.25x ULN;
  - GGT (gamma-glutamyltransferase) > 1.25x ULN;
  - Total bilirubin > 1.25x ULN;
  - Alkaline phosphatase > 1.25x ULN; or
  - INR (international normalized ratio)  $\geq$  1.4.

Subjects whose liver laboratory assessments fall outside of these ranges may undergo repeat testing of the entire liver test panel within the same Screening window and, if eligibility criteria are met on retest, may be enrolled after confirmation by the Medical Monitor.

4. Prior liver biopsy showing significant fibrosis of 3 or 4 as rated on a scale of 0-4 on the Batts-Ludwig (Batts, 1995) or METAVIR (Bedossa, 1996) scoring systems, or an equivalent grade of fibrosis if an alternative scale is used.
5. Evidence of any bleeding disorder not related to hemophilia A.
6. Platelet count of  $< 100 \times 10^9/L$ .
7. Creatinine  $\geq 1.5$  mg/dL.
8. Liver cirrhosis of any etiology as assessed by liver ultrasound.
9. Chronic or active hepatitis B as evidenced by positive serology testing (HBsAg, HBsAb, and HBcAb) and confirmatory HBV DNA testing. Refer to the Centers for Disease Control (CDC) table for the interpretation of serological test results in the Laboratory Manual.
10. Active Hepatitis C as evidenced by detectable HCV RNA or currently on antiviral therapy.
11. Active malignancy, except non-melanoma skin cancer.
12. History of hepatic malignancy.
13. History of arterial or venous thromboembolic events (eg, deep vein thrombosis, non-hemorrhagic stroke, pulmonary embolism, myocardial infarction, arterial embolus), with the exception of catheter-associated thrombosis for which anti-thrombotic treatment is not currently ongoing.
14. Known inherited or acquired thrombophilia, including conditions associated with increased thromboembolic risk, such as atrial fibrillation.
15. Treatment with any investigational product within 30 days or 5 half-lives of the investigational product prior to the screening period. For subjects who have received a prior investigational product, all ongoing adverse events (AEs) experienced while receiving that investigational product must have resolved prior to screening for this study.
16. Any condition that, in the opinion of the Investigator or Sponsor would prevent the patient from fully complying with the requirements of the study (including possible corticosteroid treatment outlined in the protocol) and/or would impact or interfere with evaluation and interpretation of subject safety or efficacy result.
17. Prior treatment with any vector or gene transfer agent.
18. Major surgery planned in the 52-week period following the infusion with BMN 270.
19. Use of systemic immunosuppressive agents, not including corticosteroids, or live vaccines within 30 days before the BMN 270 infusion.

20. Concurrent enrollment in another clinical study, unless it is an observational (non-interventional) clinical study that does not interfere with the requirements of the current protocol or have the potential to impact the evaluation of efficacy and safety of BMN 270 and with prior consultation with the Medical Monitor.
21. Known allergy or hypersensitivity to BMN 270 investigational product formulation.
22. Unwilling to receive blood or blood products for treatment of an adverse event and/or a bleeding episode.

### 9.3.2.1 Optional Liver Biopsy Inclusion and Exclusion Criteria

Individuals eligible for the optional liver biopsy must meet the following inclusion criterion:

1. Able to sign informed consent and comply with requirements for the optional liver biopsy
2. Documentation of FVIII activity  $\geq 50$  IU/dL (or higher, depending on local guidelines and/or Investigator discretion) within 24 hours prior to the liver biopsy being performed (FVIII activity levels should be assessed at the local laboratory). Subjects may be treated with additional exogenous FVIII replacement products in order to increase their FVIII levels activity to an appropriate level, under the supervision/instruction of the Investigator.

Individuals who meet any of the following exclusion criteria will not be eligible for the optional liver biopsy:

1. Any condition that, in the opinion of the Investigator or a hepatologist/radiologist would make liver biopsy contraindicated. This includes (but is not limited to) abnormalities detected on liver ultrasound performed within 28 days of procedure, or prior liver ultrasound result within 90 days that would preclude safe performance of the biopsy.

### 9.3.3 Removal of Subjects from Treatment or Assessment

Subjects may withdraw their consent to participate in the study at any time without prejudice. The Investigator must withdraw from the study any subject who requests to be withdrawn. Such subjects will always be asked about the reason(s) for withdrawal. The Investigator will discuss with the subject appropriate procedures for withdrawal from the study. The Investigator should ask the subject's consent to perform the procedures listed under the early termination visit. Should a subject withdraw from the study, all efforts will be made to complete and report the observations as thoroughly as possible up to the date of the withdrawal.

A subject's participation in the study may be discontinued at any time at the discretion of BioMarin or of the Investigator and in accordance with his/her clinical judgment. When

possible, the tests and evaluations listed for the termination visit should be carried out and every effort will be made to gather follow-up safety data if possible.

BioMarin must be notified of all subject withdrawals as soon as possible. BioMarin also reserves the right to discontinue the study at any time for either clinical or administrative reasons and to discontinue participation by an individual Investigator or site for poor enrollment or noncompliance.

Reasons for which the Investigator or BioMarin may withdraw a subject from the study include, but are not limited to, the following:

- Subject requires medication or medical procedure prohibited by the protocol
- Subject does not adhere to study requirements specified in the protocol
- Subject was erroneously enrolled into the study or does not meet entry criteria and not yet been dosed with BMN 270; subjects who do not meet entry criteria but who erroneously receive BMN 270 should remain in the study for safety monitoring
- Subject is lost to follow-up

If a subject fails to return for scheduled visits, a documented effort must be made to determine the reason. If the subject cannot be reached by telephone, a certified letter should be sent to the subject requesting contact with the Investigator. This information should be recorded in the study records.

Subjects may be considered lost to follow-up if the subject has missed 3 consecutive visits in the study and has failed to communicate a reason for this to the site. In addition, the site has documented at least 4 attempted contacts by key research personnel to reach the subject without success in the following manner:

- 2 attempts by telephone or email (if possible); then
- If telephone/email contacts are unsuccessful, 2 attempts must be made by certified letter or by appropriate local process.

Where communication has been made by phone, this should be documented in the subject source notes.

The Investigator or designee must explain to each subject, before enrollment into the study, that for evaluation of study results, the subject's protected health information obtained during the study may be shared with the study Sponsor, regulatory agencies, and IRB/IEC/REB. It is the Investigator's (or designee's) responsibility to obtain written permission to use protected health information per country-specific regulations, such as the Health Insurance Portability and Accountability Act (HIPAA) in the US, from each subject. If permission to use protected

health information is withdrawn, it is the Investigator's responsibility to obtain a written request, to ensure that no further data will be collected from the subject and the subject will be removed from the study.

### 9.3.3.1 Study Safety Evaluation Criteria

If any of the following events occur in a subject in the study who has received BMN 270 infusion, an urgent evaluation by the DMC will be required and further enrollment into the trial will be temporarily put on hold if recommended by the DMC per Section 9.1.

1. Liver dysfunction (criteria do not apply to ALT elevations with an extra-hepatic etiology):
  - ALT > 5x ULN, for more than 2 weeks
  - ALT > 3x ULN **and** (total bilirubin > 2x ULN **or** INR >1.5)
  - ALT > 3x ULN with signs and symptoms of liver dysfunction
2. The occurrence of Grade 4 or Grade 5 adverse events assessed as related to study drug (events of liver dysfunction are defined above).
3. The occurrence of an AE of hepatic failure.
4. The detection of high-titer neutralizing antibodies (>5 BU) to hFVIII following BMN 270 infusion in two subjects.
5. The occurrence of any cancer (except non-melanoma skin cancer) at any point after BMN 270 infusion.
6. The occurrence of a thromboembolic event with FVIII activity > 150 IU/dL in one subject.

If any of the following events occurs in a subject in the study who has received BMN 270 infusion, an urgent evaluation by the DMC will be required. Further enrollment into the trial will continue while DMC evaluation is ongoing, unless deemed otherwise by the DMC:

1. The detection of high-titer neutralizing antibodies (>5 BU) to hFVIII following BMN 270 infusion in one subject.
2. Occurrence of a thromboembolic event in one subject.

### 9.3.4 Subject Identification and Replacement of Subjects

Each subject will be assigned a unique subject identifier. This unique identifier will be on all eCRF pages. In legal jurisdictions where use of initials is not permitted, a substitute identifier will be used.

Subjects who withdraw from the study after receiving BMN 270 will not be replaced.



### **9.3.5 Duration of Subject Participation**

The duration of participation for each subject will be approximately 264 weeks. This includes 4 weeks of screening, 1 day of BMN 270 infusion, 52 weeks of Post-Infusion Follow-Up, and 208 weeks of Long-Term Follow-Up.

## **9.4 Treatments**

### **9.4.1 Treatments Administered**

BioMarin and/or its designee will provide the study site with a supply of IP sufficient for the completion of the study. BioMarin is responsible for shipping study drug to clinical sites.

### **9.4.2 Identity of Investigational Product**

#### **9.4.2.1 Product Characteristics and Labeling**

BMN 270 is a sterile, clear, colorless-to-pale yellow solution for IV infusion and is supplied in a 10 mL Crystal Zenith® (CZ) vial. Each vial contains 8.5 mL (extractable volume 8 mL) of AAV5-hFVIII-SQ at a concentration of 2E13 vector genomes per mL in a pH 7.4 phosphate buffer.

The study drug is labelled according to the particulars approved by the relevant regulatory agencies.

#### **9.4.3 Storage**

At the study site, all IP must be stored under the conditions specified in the Pharmacy Manual in a secure area accessible only to the designated pharmacists and clinical site personnel. All IP must be stored and inventoried and the inventories must be carefully and accurately documented according to applicable state, federal and local regulations, ICH GCP, and study procedures.

#### **9.4.4 Directions for Administration**

On the day of infusion, the subject will come to the infusion site, where a physical examination will be performed by the Investigator or designee. If the subject is found to have an active acute illness at the time of planned infusion, then the infusion should be deferred until the illness has resolved; screening procedures may require repetition if outside the specified window. An IV catheter or butterfly needle will be inserted into a suitable peripheral vein (eg, the median cubital vein) and flushed with saline. FVIII replacement therapy will not be given since venipuncture is a minimally invasive procedure in these individuals under ordinary conditions.

BMN 270 will be prepared and infused as a pure solution over a dose-dependent time. Prepared drug will be kept at room temperature prior to administration. An electric syringe pump will be used to infuse through an in-line, low protein binding 0.22 micron filter. BMN 270 will be infused through the catheter using an appropriate infusion pump at an initial rate of 1 mL/min. The infusion rate should be increased every 30 minutes by 1 mL/min up to a maximum of 4 mL/min, provided that the subject's clinical condition permits such an increase. Of note, the IP has been shown to be stable at room temperature for 7.5 hours following completion of product thaw. Vital signs (pulse, blood pressure, respiration rate and temperature) should be monitored at 15 minute ( $\pm 5$  minutes) intervals throughout the time period of the infusion.

As with any infused biological product, there is a potential risk of acute, systemic hypersensitivity reactions (including anaphylaxis) with BMN 270. Dosing will be administered at a qualified infusion site, with appropriate resuscitation equipment and medication available and easily accessible.

Clinical staff administering BMN 270 should be trained appropriately in recognizing and managing the signs and symptoms associated with potential hypersensitivity, anaphylactic, and anaphylactoid reactions. Additionally, the Investigator should be familiar with Sampson's criteria for defining anaphylaxis ([Sampson, 2006](#); Appendix 1).

Should symptoms of potential hypersensitivity occur, the infusion may be slowed or halted at the Investigator's discretion, with consideration of the subject's clinical condition. If the infusion is halted, it should only be restarted if the Investigator considers it safe and appropriate to do so. Antihistamines, anti-pyretic, and/or corticosteroid administration is permitted prior to restarting an interrupted infusion by an infusion-related reaction. At the restart, the infusion rate may be adjusted (ie, to a slower rate [minimum of 1 mL/min], with the rate increased every 30 minutes by 1 mL/min up to a maximum rate of 4 mL/min, if the subject's clinical condition permits such an increase) with careful monitoring of the subject.

In case of hypersensitivity or adverse drug reaction, safety assessment, including physical examination and vital signs, will be done and additional blood samples will be collected within 1 hour of the hypersensitivity reaction (eg, tryptase, C3, C3a, C4, C5, C5a, and cytokine bead array, as well as possible additional exploratory testing) and samples for IgE and cytokine bead array (and possible additional exploratory testing) between 8-24 hours after the reaction, if possible. In addition, a blood sample should be taken 1 week after the hypersensitivity reaction for assessment of the cytokine bead array. In-patient observation can be extended and additional blood samples can be collected if deemed necessary at the discretion of the Investigator and Medical Monitor.

Following completion of the infusion, vital signs will be monitored hourly ( $\pm$  5 minutes). If the vital signs are stable the catheter will be removed 8 hours after the infusion. Hemostasis at the puncture site will be established by applying pressure according to standard protocol for infusing FVIII concentrates. Subjects will remain in the clinic for at least 8 hours to observe for any immediate toxicity of the procedure; in-patient observation can be extended beyond 8 hours if needed per Investigator discretion, or the subject may transfer to a separate facility based on the evaluation and judgment of the Principal Investigator after consultation with the Medical Monitor.

Prior to discharging subjects from the clinic, the Investigator or designee should instruct subjects how to recognize signs and symptoms of potential (delayed) hypersensitivity reactions and anaphylaxis, and to contact a medical practitioner or seek emergency care in case of such an event.

#### **9.4.5 Method of Assigning Subjects to Treatment Groups**

Subjects who meet all eligibility criteria (refer to Section 9.3.1 and Section 9.3.2) may be enrolled into the study. Approval by the Medical Monitor will be required prior to enrollment of each study subject. Upon their enrollment into the study, subjects will be assigned a unique subject number.

Approximately 130 subjects will be enrolled at 6E13 vg/kg.

#### **9.4.6 Selection of Dose Used in the Study**

Data from an ongoing first in human study (Clinical Study 270-201) indicates that following single escalated doses of BMN 270 (6E12, 2E13, 4E13, 6E13 vg/kg), dose-related increases in FVIII activity were observed, with concurrent improvements in bleeding episodes and exogenous FVIII utilization, particularly at the 4E13 and 6E13 vg/kg dose levels. At all dose levels, BMN 270 is considered to be well-tolerated with mild increases in ALT as the most common adverse event. Please refer to the IB for detailed efficacy and safety data.

In order to further evaluate the dose-response relationship of BMN 270, subjects will be enrolled at a dose of 6E13 vg/kg. This dose is expected to be safe and effective based on clinical experience to date in 270-201. The DMC will review emerging safety and efficacy data and may recommend that a different dose (not to exceed 6E13 vg/kg) be administered. In such a case, up to 130 additional subjects may be enrolled at the new dose.

#### **9.4.7 Blinding**

This is an open-label study.

In order to minimize bias and to preserve the scientific and business integrity of the single-arm and open-label study, a data access plan (DAP) has been implemented. This document provides guidelines for accessing post-treatment study data and applies to study team members, including personnel from within BioMarin, from external vendors and service providers, from the DMC, and from study sites. Role-based access control to study data, both individual patient-level data values as well as aggregated summaries of longitudinal data in an individual patient or across multiple patients, has been implemented to minimize potential bias and achieve appropriately controlled decision-making, while preserving operational efficiency. It is enforced by the DAP that individuals who are designated to have knowledge of the key efficacy variables (FVIII activity, FVIII usage, and bleeding counts) will not make or influence decisions that would alter the study design or conduct, or the collection or analysis of the key efficacy variables so as to bias the studies' key efficacy results.

#### **9.4.8 Prior and Concomitant Medications**

All prescription and over-the-counter medications (including dietary and herbal supplements) taken by a subject for 30 days before Screening will be recorded on the designated eCRF. The Investigator may prescribe additional medications, deemed necessary to provide adequate prophylactic or supportive care, during the study, as long as the prescribed medication is not prohibited by the protocol. In the event of an emergency, any needed medications may be prescribed without prior approval, but the Medical Monitor must be notified of the use of any contraindicated medications immediately thereafter. Any concomitant medications added or discontinued during the study should be recorded on the eCRF. Medications should, whenever possible, not be recorded in the electronic database with a frequency of PRN.

The following medications are prohibited starting 30 days before Screening and through the end of the study, and the Sponsor must be notified if a subject receives any of these during the study:

- Any investigational therapy
- Emicizumab
- Fitusiran
- Concizumab
- Efavirenz

The following medications should be avoided, starting 30 days prior to and for at least 52 weeks after BMN 270 infusion and minimized throughout the remaining duration of the study.

- Alcohol
- Herbal and natural remedies and dietary supplements
- Medications which may be hepatotoxic, including isotretinoin and dextroamphetamine/amphetamine
- Medications which may reduce or increase the plasma concentration of corticosteroids

Subjects should be counseled to avoid starting potentially hepatotoxic therapies and to inform the Investigator of any new medications prescribed by other physicians. Investigators should carefully consider both the mechanism of action and potential hepatotoxicity of any new medication prior to initiation. If a potentially concerning new medication is started, Investigators should closely monitor both FVIII activity and ALT levels (eg, weekly to every 2 weeks for the first month) in order to determine if any detrimental effects on the efficacy or safety of BMN 270 have occurred. If co-medications are required during the course of the study, where possible, please check the National Center for Biotechnology Information LiverTox website for potential hepatotoxicity issues prior to prescribing ([NCBI, 2020](#)).

Vaccines should also be avoided during this period, but in particular during the first 26 weeks unless clinically indicated.

The following medications should be avoided during oral corticosteroid therapy:

- Vaccines
- NSAIDs

#### **9.4.8.1 Concomitant Hemophilia Treatments**

Subjects on prophylactic FVIII therapy will discontinue their regular treatment regimen starting 4 weeks after the day of infusion and switch to an “on-demand” schedule. FVIII replacement therapy can always be taken as needed by the subject for treatment of an acute bleeding episode; the subject must carefully record his treatment and bleeding episodes in his diary. Prophylactic FVIII use can be used on a case-by-case basis and in consultation with the Medical Monitor to prevent bleeding in extenuating circumstances (eg, peri-operative).

In addition, information on FVIII usage and bleeding episodes by medical history must be well-documented and available and will be collected from subjects for the 12-month period immediately preceding study enrollment. Further information on the details that should be

provided as part of the subject's well-documented medical and FVIII usage history are provided in the On Site File Binder.

In order to enable rigorous comparisons of pre-study versus on-study FVIII usage and bleeding episodes, the Medical Monitor will review each screened patient's prior bleed and hemophilia medication logs to determine if they are of "high-quality". Elements that will be assessed to judge the quality of such historical data may include, but are not limited to, the following:

- Date, type (eg, joint, muscle, other), location of bleeds
- Date, name, dose (calculated in IU/kg), and reason for use (eg, usual prophylaxis, one-time prophylaxis, treatment for bleed, surgery) of hemophilia medications.

#### **9.4.8.2 Therapeutic Glucocorticoid Treatment and/or Immunosuppressive Agent Treatment of Elevated Hepatic Transaminases**

Refer to corticosteroid prescription guidelines for recommended monitoring for, and management of, potential side effects of corticosteroids, including guidance on medications that should be avoided during corticosteroid treatment.

Therapeutic oral corticosteroids (prednisone or converted equivalent) should be initiated when either of the following occurs post-BMN 270 infusion in any subject and after consultation with the Medical Monitor (or their designee):

- ALT > ULN or  $\geq 1.5x$  baseline value in 2 consecutive assessments within 72 hours and alternative etiologies have been ruled out, or ALT  $\geq 3x$  ULN in 2 consecutive assessments within 48 hours (refer to [Table 9.7.8.3.2](#))
  - Whenever possible, a confirmatory lab draw for ALT should be performed, along with FVIII activity, prior to initiating oral corticosteroids.
  - Corticosteroids may be delayed if elevations in ALT are clearly not related to BMN 270 (eg, elevated ALT with concurrent increase in CPK due to intensive exercise)
  - Alternative immunosuppressive agents may also be considered for use on a case-by-case basis and following consultation with the Medical Monitor (eg, if prolonged corticosteroid use is contraindicated).

The prescribed regimen for therapeutic oral corticosteroids is detailed in [Table 9.1.6](#). Changes to the corticosteroid regimen should be made as follows ([Table 9.4.8.2.1](#)):

**Table 9.4.8.2.1: Adjustments to Corticosteroid Regimen**

|  |  |
|--|--|
| <b>Corticosteroids should be tapered on an individual subject basis with the following guiding principles:</b> | Corticosteroids may be tapered if: <ul style="list-style-type: none"> <li>• ALT <math>\leq</math> 1.5x baseline value; and</li> <li>• FVIII activity levels &gt; 90% of the pre-decline FVIII activity levels; and</li> <li>• There is no concern for adrenal insufficiency post-withdrawal</li> </ul> |
| <b>Increasing Corticosteroid Dose</b>  | If ALT level is increasing or FVIII level is decreasing while on oral corticosteroids, any increases in oral corticosteroid dosing should be made only upon consultation with the Medical Monitor  |

For any scenarios that are not accounted for in the above table, a discussion should take place between the Investigator and Medical Monitor regarding corticosteroid dose adjustments.

After discontinuation of oral corticosteroids, labs for ALT and FVIII levels will be measured once a week for 4 weeks to ensure stability in values.

Following initiation or completion of therapeutic oral corticosteroids, if ALT elevation (eg, > ULN or  $\geq$ 1.5x baseline value) is reported, corticosteroid management decisions will be based on discussions between the Investigator and Medical Monitor. Modification of the corticosteroid regimen may take into consideration possible confounders for the ALT elevation and impact on FVIII expression.

Management and monitoring of reactions to corticosteroids should be determined by the Investigator's clinical judgment in consultation with the Sponsor's Medical Monitor. This includes the contraindicated use of NSAIDs during corticosteroid treatment and specific monitoring not already covered by the schedule of events. The use of COX-2 inhibitors, while not contraindicated during corticosteroid treatment, should be limited, if possible. Practical management to prevent complications related to oral corticosteroid therapy may be undertaken at the discretion of the Investigator (eg, evaluation of glucose intolerance, hyperlipidemia etc.). Alternative, non-steroidal systemic immunosuppressive agents may be used, following a discussion between the Investigator and the Medical Monitor, should corticosteroid use be deemed by an Investigator to be clinically ineffective, not tolerated, and/or contraindicated. Hepatitis B status and HCV viral load will be rechecked 6 weeks after the start of oral corticosteroid/immunosuppressive agent treatment and then 1 week and 13 weeks after the completion of oral corticosteroid/immunosuppressive agent treatment in subjects with a history of hepatitis B or hepatitis C. All adverse events (including any adverse events suspected to be caused by or related to corticosteroid/immunosuppressive agent use) should be reported as outlined in Section 10 of the protocol.



Subjects on corticosteroids should receive appropriate counselling and support regarding side effects from the Investigator or the treating institution (eg, listings of side effects and when to notify carers, wallet card for emergencies if on steroids, etc.). Additional management, including the co-prescription of additional medications to prevent complications related to corticosteroid therapy, may be undertaken at the discretion of the investigator, including, but not limited to, prophylaxis against the occurrence of gastric ulcers, osteoporosis, and infections. The above guidance should also be followed in the event that an alternative immunosuppressive agent is used, as applicable.

#### **9.4.8.3 Monitoring of HIV-Positive Subjects**

HIV-positive subjects who have previously enrolled in 270-301 should continue anti-retroviral therapy (ART) as prescribed and follow routine monitoring of CD4 count and viral load ([US Dept Health Human Services, 2014](#)). No alterations in the monitoring are indicated for enrolled immunocompetent HIV-positive subjects who receive corticosteroids as part of their enrollment in 270-301.

#### **9.4.9 Treatment Compliance**

Study drug will be administered to subjects at the study site and/or the dosing facility by a qualified health care professional. The quantity dispensed, returned, used, lost, etc. must be recorded on a dispensing log. Sites will be instructed to return or destroy all used and unused study drug containers.

### **9.5 Investigational Product Accountability**

The Investigator or designee is responsible for maintaining accurate records (including dates and quantities) of IP(s) received and IP lost or accidentally or deliberately destroyed.

The Investigator or designee must retain all unused or expired study supplies until the study monitor (on-site CRA) has confirmed the accountability data, if allowed by local SOPs.

#### **9.5.1 Return and Disposition of Clinical Supplies**

Unused study drug must be kept in a secure location for accountability and reconciliation by the study monitor. The Investigator or designee must provide an explanation for any destroyed or missing study drug or study materials (or must be referenced in their institution SOPs).

Unused study drug may be destroyed on site, per the site's standard operating procedures, but only after BioMarin has granted approval for drug destruction. The monitor must account for all study drug in a formal reconciliation process prior to study drug destruction. All study drug destroyed on site must be documented. Documentation must be provided to BioMarin or



designee and retained in the Investigator study files. If a site is unable to destroy study drug appropriately, the site can return unused study drug to BioMarin upon request. The return of study drug or study drug materials must be accounted for on a study drug return form provided by BioMarin.

All study drug and related materials should be stored, inventoried, reconciled, and destroyed or returned according to applicable state and federal regulations and study procedures. For additional information, please refer to the Pharmacy Manual.

## **9.6 Dietary or Other Protocol Restrictions**

There are no dietary or other protocol restrictions for this study. Alcohol should be avoided for the first 52 weeks of the study, and particularly within 48 hours prior to lab work. Alcohol use should be minimized throughout the remaining duration of the study.

Subjects should be advised to abstain from any blood or sperm donation after BMN 270 infusion, until there is no further evidence of vector shedding from PCR analysis of samples. Subjects should also abstain from organ donation.

## **9.7 Safety and Efficacy Variables**

### **9.7.1 Safety and Efficacy Measurements Assessed**

The Schedule of Events ([Table 9.1.1](#) through [Table 9.1.5](#)) describes the timing of required evaluations.

### **9.7.2 Primary Efficacy Variables**

#### **9.7.2.1 FVIII Activity**

The primary efficacy variable is change of the hFVIII activity, as measured by chromogenic substrate assay, during Weeks 49-52 post-BMN 270 infusion from baseline. Each subject's hFVIII activity during Weeks 49-52 is defined as the median of the values obtained during this 4-week window. Values for FVIII activity will be excluded if obtained within 72 hours since the last infusion of exogenous FVIII protein concentrates.

If a subject has used FVIII within 72 hours of a measurement day, all efforts should be made to obtain FVIII activity measurements when a 72-hour interval without FVIII use is achieved; The 72-hour wash-out period is only intended for subjects who have achieved  $FVIII \geq 5$  IU/dL at 16 weeks after BMN 270 infusion and who have not resumed FVIII replacement therapy.

In the event of an FVIII activity level decline during the study:

- If FVIII activity has declined at least 20% from the peak but less than 35% and has declined for at least 2 consecutive assessments, FVIII activity and LTs should be repeated every 7 days until FVIII activity is stable or increasing
- If FVIII activity has declined >35% from the peak and has declined for at least 2 consecutive assessments, FVIII activity and LTs should be repeated every 72 hours until FVIII activity is stable or increasing

Note that fluctuations in FVIII activity are common, and if no clear trend indicating a decline in FVIII activity is observed, then this additional testing may be deferred (upon consultation between the Investigator and the Medical Monitor) until either a more clear trend of decline has been demonstrated or until the FVIII activity levels stabilize or increase.

Subjects who do not respond to BMN 270 treatment (ie treatment failure, manifesting as either failure to achieve FVIII activity  $\geq 5$  IU/dL by Week 52 or inability to maintain independence from prophylactic FVIII replacement therapy due to joint bleeding episodes, in the judgment of the Investigator) may, at the Investigator's discretion and after discussion with the Medical Monitor or Sponsor-designated Data Monitor, follow an abbreviated visit schedule after Week 52 of the study by attending only the Q12W and End of Year visits during Years 2-5. Subjects who are not attending the Q4W/Q6W visits during Years 2-5 may receive a scheduled monthly follow-up telephone call from the site to ask about adverse events, concomitant medications, and bleeding events/FVIII replacement usage.

Details on collecting FVIII activity samples are included in the Laboratory Manual.

### **9.7.3 Secondary Efficacy Variables**

#### **9.7.3.1 Factor VIII Replacement Therapy/Bleeding Episodes**

Secondary efficacy variables are:

- Change of the annualized utilization (IU/kg) of exogenous FVIII replacement therapy during Week 5 to Week 52 post BMN 270 infusion from the baseline utilization of exogenous FVIII replacement therapy.
- Change in the annualized number of bleeding episodes requiring exogenous FVIII replacement treatment during Week 5 to Week 52 of the study post BMN 270 infusion from the baseline ABR.

Subjects must have high quality documented historical data available concerning previous bleeding episodes and exogenous FVIII usage over the previous 12 months in order to be eligible to enroll in the study. During the study, subjects will be asked at each study visit to report the use of factor replacement therapy and the number of bleeding episodes since the

previous visit. This information will be captured on the subject's diary or other subject records.

Subjects are strongly encouraged to immediately consult Investigator for guidance regarding exogenous FVIII administration for suspected bleeds or bleeding episodes within the first 30 days post BMN 270 infusion.

In subjects who experience recurrent bleeding episodes, the Investigator and Medical Monitor will discuss whether to resume prior FVIII prophylaxis.

#### **9.7.4 Tertiary Efficacy Variables**

##### **9.7.4.1 Patient-Reported Outcomes (PRO)**

The Haemo-QoL-A questionnaire is a validated hemophilia-specific health-related quality of life questionnaire for adults (Rentz, 2008). It consists of 41 questions covering six domains (Physical Functioning, Role Functioning, Worry, Consequences of Bleeding, Emotional Impact and Treatment Concerns). Items are answered on a 6-point Likert-type scale, ranging from 0 (None of the time) to 5 (All of the time). Higher scores mean better health-related quality of life or less impairment for a particular subscale (Haemo-QoL Study Group, 2017). Details regarding the Haemo-QoL-A assessment will be included in the On Site File Binder.

The EQ-5D-5L instrument is a self-reported questionnaire designed to measure general health status (The EuroQol Group, 1990) (Brooks, 1996). The EQ-5D-5L is composed of 2-parts: a descriptive system that assesses 5 levels of perceived problems (mobility, self-care, usual activities, pain/discomfort, and anxiety/depression) in 5 dimensions and the EQ visual analogue scale (EQ VAS) assessment for overall health. A sample copy of the EQ-5D-5L and additional information are provided in the On Site File Binder.

The Haemophilia Activities List (HAL) measures the impact of hemophilia on self-perceived functional abilities in adults (Van Genderen, 2006). The instrument consists of multiple domains including lying/sitting/kneeling/standing, leg and arm function, use of transportation, self-care, household tasks, and leisure activities where subjects are asked to rate their level of difficulty with activities of daily living on a 6-point Likert-type scale from 1 (Impossible) to 6 (Never). For some items, subjects are given the choice to answer 'Not applicable'. A sample copy of the HAL and additional information are provided in the On Site File Binder.

The Work Productivity and Activity Impairment plus Classroom Impairment Questions: Hemophilia Specific (WPAI+CIQ:HS) instrument is designed to measure the effect of disease symptom severity on work productivity and classroom productivity (if applicable)

(Recht, 2014). The WPAI+CIQ:HS questionnaire yields scores related to work/classroom absenteeism, reduced on-the-job effectiveness, overall work/classroom impairment, and activity impairment. WPAI+CIQ:HS outcomes are expressed as impairment percentages, with higher numbers indicating greater impairment and less productivity (Reilly, 2002). A sample copy of the WPAI+CIQ:HS and additional information are provided in the On Site File Binder.

The Patient Reported Outcomes, Burdens, and Experiences (PROBE) questionnaire is designed to investigate and directly probe patient perspectives on outcomes they deem relevant to their life and care. PROBE aims to develop a new global tool to enhance the direct patient-voice in health care decision-making (Chai-Adisaksopha, 2017). PROBE data collected in 270-301 will be shared with the Patient Outcomes Research Group (PORG) in order to facilitate validation of the tool; subjects may opt out of having their data used for this purpose. A sample copy of the PROBE questionnaire and additional information are provided in the On Site File Binder.

#### **9.7.5 Immunogenicity**

Immunogenicity assays will be performed on plasma and PBMCs. The assays will include detection of anti-AAV5 capsid and anti-FVIII total antibodies, as well as determination of neutralizing antibodies against FVIII (FVIII inhibitors) and against the AAV5 capsid (Transduction Inhibitors, TI). FVIII Inhibitors will be assessed using the Bethesda assay with Nijmegen modification. Any abnormality of the liver parameters will lead to a retrospective immunogenicity assessment to evaluate FVIII- and capsid-specific cellular immunogenicity. FVIII- and capsid-specific cellular immunity will be assessed by stimulated cytokine secretion using an ELISpot assay performed on collected PBMCs.

#### **9.7.6 Pharmacodynamics**

The FVIII protein concentration and activity level as measured by a validated immunoassay and by a validated FVIII activity assay, respectively, will be used for plasma profiles; FVIII protein and activity will be used to determine PD parameters.

#### **9.7.7 Exploratory Assessments**

Blood samples will be collected from subjects at the time points indicated in [Table 9.1.1](#), [Table 9.1.2](#), [Table 9.1.3](#), [Table 9.1.4](#), and [Table 9.1.5](#) to evaluate biochemical, molecular, cellular, and genetic/genomic aspects relevant to hemophilia A, coagulation, and/or AAV gene transfer, and to develop assays used for these evaluations. Subjects may choose to opt out of the exploratory genetic/genomic research being done to study or try to discover genes that are not yet known to be associated with hemophilia A.

All biomarker samples collected in this study may be used for exploratory biomarker research, including evaluation of additional biomarkers not specifically listed in the protocol. In addition, samples collected for other purposes in this study may be used for exploratory research once testing for the primary purpose has been completed.

#### 9.7.7.1 Optional Liver Biopsy

Subjects electing to undergo an optional liver biopsy are required to consent to the procedure and collection of tissue in the study ICF. The analysis of the optional liver biopsy is considered exploratory. Subject who elect to proceed will have a liver biopsy performed during Year 1 post-infusion, at or around Week 52, and/or during Years 2-5. Additional liver biopsies at times deemed to be clinically relevant (eg, decreasing FVIII at a time of increased ALT) may be pursued. Subjects will be asked to consent to the procedure for each liver biopsy performed during the study.

Subjects who consent to the procedure will have a liver biopsy via either transjugular or percutaneous (ultrasound-guided) route, according to the standard procedures of the institution. Two tissue cores will be harvested in the context of the optional liver biopsy. Subjects will be required to observe an 8-hour fasting period before the procedure.

Within 24 hours prior to the biopsy being performed, subjects must have a documented FVIII activity level of  $\geq 50$  IU/dL (or higher, depending on local guidelines and/or investigator discretion). FVIII activity levels for this purpose should be assessed at the local laboratory within 7 days before the biopsy and again on the day the biopsy, prior to the procedure. As needed, subjects may be treated with additional exogenous FVIII replacement products in order to increase their FVIII activity levels to an appropriate level, under the supervision/instruction of the investigator, to ensure the safety of the subject during the procedure. This exogenous FVIII usage (if performed) should be recorded in the eCRF FVIII infusion pages under the category "Surgery/Procedure".

Details on required procedures for the optional liver biopsy are outlined in [Table 9.1.7](#). Subjects consenting to participate to the optional liver biopsy will undergo pre-biopsy assessments at least 28 days before the procedure, as follows:

- Physical examination
- Hematology, coagulation, chemistry assessments
- Liver tests
- Liver ultrasound (subject should fast at least 8 hours prior to ultrasound)
- FibroScan

Subjects consenting to participate to the optional liver biopsy will undergo pre-biopsy assessments at least 7 days before the procedure, as follows:

- Local FVIII activity level assessment
- Pre-biopsy consultation (with hepatologist and/or radiologist)

On the day of the biopsy, brief physical examination and liver and blood tests should be performed before the procedure (including hematology, coagulation, and chemistry). FVIII activity assessment should also be performed to ensure the subject has sufficient FVIII activity to protect against procedure-related bleeding (as discussed above). LT assessment and a whole blood draw for PBMC collection should be performed on the biopsy day or  $\pm 1$  week from the biopsy day.

The optional liver biopsy should be performed in the morning if feasible, and the biopsy procedure and follow-up care should be done according to the local standard of care. Additional details for handling the biopsy specimens are provided in the Laboratory Manual.

Following completion of the biopsy, the subject should remain under observation in the clinic for at least 4-6 hours. Overnight post-procedure observation may be done at the investigator's discretion and/or according to local guidelines.

Clinically significant findings reported from the histopathological analysis of the biopsy sample are subject to AE reporting (Section 10). Such findings should be further assessed and followed as clinically appropriate to manage the subject's medical care. A hepatologist and/or other specialist clinicians should be consulted if required. In the event that fibrotic changes are observed on the biopsy sample, additional liver ultrasound, FibroScan and/or Enhanced Liver Fibrosis (ELF) testing (as regionally available and/or approved by HA) may be considered at the discretion of the investigator and/or hepatologist.

### **9.7.8 Safety Variables**

Safety in this study will be determined from evaluation of AEs, clinical laboratory assessments with a particular attention to the liver function, vital signs assessments, physical examinations, and immunogenicity.

#### **9.7.8.1 Adverse Events**

The determination, evaluation and reporting of AEs will be performed as outlined in Section 10.

### 9.7.8.2 Clinical Laboratory Assessments

The scheduled clinical laboratory tests are listed in [Table 9.7.8.2.1](#). Refer to the On Site File Binder for instructions on obtaining and shipping samples.

Any abnormal test results determined to be clinically significant by the Investigator should be repeated (at the Investigator's discretion) until: (1) the cause of the abnormality is determined; (2) the value returns to baseline or to within normal limits; or (3) the Investigator determines that the abnormal value is no longer clinically significant.

All abnormal clinical laboratory results should be initialed and dated by an Investigator, along with a comment regarding whether or not the result is clinically significant. Each clinically significant laboratory result should be recorded as an adverse event.

The diagnosis, if known, associated with abnormalities in clinical laboratory tests that are considered clinically significant by the Investigator will be recorded on the AE eCRF.

**Table 9.7.8.2.1: Clinical Laboratory Tests**

| Blood Chemistry   | Hematology                | Urine Tests      | Coagulation Screen including: |
|-------------------|---------------------------|------------------|-------------------------------|
| Albumin           | Hemoglobin                | Appearance       | APTT                          |
| BUN               | Hematocrit                | Color            | PT/INR                        |
| Calcium           | WBC count                 | pH               | TT                            |
| Chloride          | RBC count                 | Specific gravity |                               |
| Total cholesterol | Platelet count            | Ketones          |                               |
| CPK               | Differential cell count   | Protein          |                               |
| Creatinine        | RBC indices (MCV and MCH) | Glucose          |                               |
| CRP               | ABO blood typing*         | Bilirubin        |                               |
| Glucose           |                           | Nitrite          |                               |
| Phosphorus        |                           | Urobilinogen     |                               |
| Potassium         |                           | Hemoglobin       |                               |
| Total protein     |                           |                  |                               |
| Sodium            |                           |                  |                               |
| Uric Acid         |                           |                  |                               |

BUN, blood urea nitrogen; CPK, creatinine phosphokinase; CRP, C-reactive protein; PT, prothrombin time; APTT, activated partial thromboplastin time; RBC, red blood cell; WBC, white blood cell; TT, thrombin time; INR, international normalized ratio; MCV, mean corpuscular volume; MCH, mean corpuscular hemoglobin.

\*ABO blood typing assessment should be performed at Baseline, or at another regularly scheduled visit prior to the end of the subject's participation in the study.



In addition to scheduled clinical laboratory assessments, a fasting blood lipid panel (including triglycerides, total cholesterol, HDL cholesterol, and LDL cholesterol) will be assessed at the BMN 270 infusion visit. Subjects will fast for at least 8 hours prior to pre-infusion laboratory sampling on the day of the infusion visit.

In case of hypersensitivity or adverse drug reaction, safety assessment, including physical examination and vital signs, will be done and additional blood samples will be collected within 1 hour of the hypersensitivity reaction (eg, tryptase, C3, C3a, C4, C5, C5a, and cytokine bead array, as well as possible additional exploratory testing) and samples for IgE and cytokine bead array (and possible additional exploratory testing) between 8-24 hours after the reaction. In addition, a blood sample should be taken 1 week after the hypersensitivity reaction for assessment of the cytokine bead array.

At applicable sites, certain study assessments designed in the Schedule of Events may be performed by a mobile nursing (MN) professional at the patient's home or another suitable location, such as their school or office, to improve access and convenience for patients participating in the study. The Sponsor may select a healthcare company that will be responsible for providing MN services for participating sites (the MN vendor). The MN vendor is responsible for ensuring that all MN professionals are licensed, qualified, and in good standing, as per applicable regulations, and that appropriate background checks have been performed. If the investigator at a participating site determines that MN services are appropriate for a patient and the patient gives written informed consent to participate in MN visits, the MN network will communicate with the patient and the patient's site.

For all subjects, MN visits will be allowed for the Q4W (during Year 2) and Q6W (during Years 3-5) visits; the Q12W visits and End of Year visits during Years 2-5 will not be performed by an MN professional but will be done at the study site. For subjects who have enrolled in 270-301 following participation in 270-902, MN visits may also be available during Year 1 at Weeks 5, 7, 9, 11, 13, 15, 17, 19, 21, 23, 25, 27, 29, 30, 31, 33, 34, 35, 38, 42, 46, and 50 (as indicated in the Schedule of Events). At visits not specifically designated for MN eligibility (ie, visits where the subject is intended to return to the site for assessment), MN services may be used if the subject is unable to attend the site to complete the study visit during the acceptable window for that visit, upon prior approval by the Medical Monitor and discussion between the Medical Monitor and Investigator.

In the event that neither a lab-only visit or MN visit can be conducted for a post-infusion visit, the site should telephone the subject to collect adverse event, concomitant medication, and diary data (bleeding events and FVIII usage), in the interest of monitoring subject safety and welfare.



### 9.7.8.3 Liver and Hepatitis Testing

Subjects will be screened for evidence of previous or active hepatitis B or hepatitis C infection at Screening; hepatitis B screening should include HBsAg, HBsAb, and HBcAb. Subjects with documented results showing an absence of active hepatitis B or hepatitis C infection (as measured by positive DNA for hepatitis B or positive RNA testing for hepatitis C) 30 days prior to providing signed informed consent do not need to repeat those tests during the screening period.

Evidence of ongoing hepatitis B or hepatitis C infection is exclusionary. Subjects with a history of hepatitis B or hepatitis C infection prior to study entry will be tested for hepatitis B and hepatitis C reactivation at Week 16. Subjects with a history of hepatitis B or hepatitis C will be asked for information about the treatments received as part of their medical history assessment at Screening.

Subjects with a previous history of hepatitis B or hepatitis C who receive therapeutic oral corticosteroids prior to Week 16 do not need to complete the Week 16 reactivation assessment; instead, they will be tested for hepatitis B and hepatitis C reactivation at the time points listed in [Table 9.1.6](#).

A liver ultrasound and liver tests (LTs) during Screening will identify any significant hepatic dysfunction.

LTs will be monitored on a regular basis; at each time point, the following LTs should be assessed:

**Table 9.7.8.3.1: Liver Tests**

| Liver Tests (LTs)    |                  |                 |     |
|----------------------|------------------|-----------------|-----|
| Alkaline Phosphatase | AST (SGOT)       | Total Bilirubin | LDH |
| ALT (SGPT)           | Direct Bilirubin | GGT             |     |

ALT, alanine aminotransferase; AST, aspartate aminotransferase; GGT, gamma-glutamyltransferase; LDH, lactate dehydrogenase; SGOT, serum glutamic-oxaloacetic transaminase; SGPT, serum glutamic-pyruvic transaminase

Elevated ALT levels (above the upper limit of normal range) should be evaluated according to the following plan (note that these evaluations may indicate additional testing of LTs and FVIII levels at unscheduled visits; these unscheduled laboratory tests may be completed by a mobile nursing professional at sites where the use of MN services has been approved):

**Table 9.7.8.3.2: Evaluation of ALT Elevations**

| ALT Level                                    | Work-Up  |
|--|--|
| <p>≥1.5x Baseline<br/>- &lt; 2x Baseline</p> | <ul style="list-style-type: none"> <li>• Continue to monitor LTs and FVIII per protocol (repeat within 7 days if next protocol scheduled visit is &gt;7 days from the time of the reported ALT elevation)</li> <li>• Consider evaluation to rule out alternative etiology (eg, concomitant medications, viral or autoimmune hepatitis, alcohol use, recreational drug use, special diets, strenuous exercise, prior and/or concurrent illnesses, exposure to environmental and/or industrial chemicals, etc.) (refer to <a href="#">Table 9.7.8.3.3</a>)</li> <li>• If ALT is &gt; ULN or &gt; 1.5x baseline in 2 consecutive assessments within 24-72 hours and alternative etiologies have been ruled out, start oral corticosteroids upon consultation with the Medical Monitor (refer to <a href="#">Section 9.4.8.2</a>)</li> <li>• Consider liver biopsy at the discretion of the Investigator or Medical Monitor</li> </ul>   |
| <p>≥2x Baseline or &gt; ULN - &lt;3x ULN</p> | <ul style="list-style-type: none"> <li>• Repeat LTs and FVIII within 72 hours</li> <li>• Continue to monitor LTs weekly until ALT is stable or improving</li> <li>• Evaluate and rule out alternative etiologies (as above)</li> <li>• Consult with Medical Monitor</li> <li>• If ALT is ≥ 2x baseline or &gt; ULN - &lt; 3x ULN in 2 consecutive assessments within 72 hours and alternative etiologies have been ruled out, start oral corticosteroids (refer to <a href="#">Section 9.4.8.2</a>)</li> <li>• Obtain other possibly relevant laboratory evaluations (albumin, PT/INR, CRP, etc.)</li> <li>• Obtain complete blood count with differential to assess for eosinophilia</li> <li>• Obtain PBMC to evaluate potential immune response (prior to starting oral corticosteroids)</li> <li>• If no improvement in 14 days, consider gastroenterology and/or hepatology consult, abdominal workup, imaging (including MRI or ultrasound), and/or liver biopsy as appropriate</li> </ul>   |
| <p>≥3x ULN</p>                               | <ul style="list-style-type: none"> <li>• Consult with Medical Monitor</li> <li>• Evaluate and rule out alternative etiologies (as above)</li> <li>• Repeat LTs and FVIII within 48 hours, and continue with monitoring of LTs at least twice weekly for as long as the subject's ALT remains ≥ 3x ULN</li> <li>• In the event that ALT or AST is ≥3x ULN and total bilirubin is ≥2x ULN, albumin and PT/INR should also be obtained.</li> <li>• If ≥ 3x ULN in 2 consecutive assessments within 48 hours, start oral corticosteroids (refer to <a href="#">Section 9.4.8.2</a>)</li> <li>• Obtain other possibly relevant laboratory evaluations (albumin, PT/INR, CRP, etc.)</li> <li>• Obtain complete blood count with differential to assess for eosinophilia</li> <li>• Obtain PBMC to evaluate potential immune response (prior to starting oral corticosteroids)</li> <li>• If no improvement in 14 days, consider gastroenterology and/or hepatology consult, abdominal workup, imaging (including MRI or ultrasound), and/or liver biopsy as appropriate</li> </ul> |

When ruling out alternative viral or autoimmune hepatitis as part of the elevated ALT workup, the following tests should be performed:

**Table 9.7.8.3.3: Viral and Autoimmune Hepatitis Testing**

| <b>Viral Hepatitis Workup Testing</b> | <b>Autoimmune Hepatitis Workup Testing</b> |
|---------------------------------------|--|
| Hepatitis A                           | Smooth muscle antibody                     |
| Hepatitis B                           | Mitochondrial antibody                     |
| Hepatitis C                           | Liver/kidney microsomal antibodies         |
| Hepatitis E                           | Antinuclear antibody (ANA) HEP-2           |
| Cytomegalovirus (CMV)                 |  |
| Epstein-Barr virus (EBV)              |  |
| Herpes simplex virus (HSV) 1 & 2      |  |

#### **9.7.8.4 HIV Testing**

HIV testing will be performed at Screening. Subjects with documented negative results within the last 30 days prior to screening do not need to be retested.

#### **9.7.8.5 Vital Signs, Physical Examinations and Other Observations Related to Safety**

Vital signs will include seated systolic and diastolic blood pressure, heart rate, respiration rate, and temperature. Any clinically significant change in vital signs will be recorded as an AE.

Systolic blood pressure, diastolic blood pressure, heart rate, respiration rate, and temperature will be assessed at Screening, Baseline, and at the beginning of each visit during the Post-Infusion Follow-Up and Long-Term Follow-Up periods. On the day of the BMN 270 Infusion, vital signs will be monitored prior to infusion, during the infusion every 15 minutes ( $\pm 5$  minutes), following the infusion hourly ( $\pm 5$  minutes) for at least 8 hours during the subject's stay in the clinic. Any abnormal vital sign assessments should be repeated, and both values should be recorded in the eCRF.

A complete physical examination is necessary during Screening/Baseline, at Week 26 and 52 and every 52 weeks thereafter; at other visits, brief physical examinations may be performed at the discretion of the Investigator based on the subject's clinical condition. Particular attention should be given to signs of bleeding, as well as assessing possible hemarthroses. During Year 1, at visits where the MN services are used or shortened lab draw-only visits are conducted at the sites, the physical examination and vital signs assessments indicated in the Schedule of Events will not be performed.

A complete physical examination will include general appearance (head, eyes, ears, nose, and throat), cardiovascular, dermatologic, lymphatic, respiratory, gastrointestinal, genitourinary, musculoskeletal, and neurologic systems.

A brief physical examination will include general appearance, cardiovascular, dermatologic, respiratory, gastrointestinal, musculoskeletal, and neurologic assessments.

Height will be recorded at Screening only. Weight will be recorded at Screening and then every 4 weeks thereafter through Week 52, and at the second Q12W visit each year and at every End of Year visit during Years 2-5.

#### **9.7.8.6 Vector Shedding**

During the Post-Infusion Follow-Up period, subjects will undergo testing of various bodily samples to look for evidence of vector shedding for possible viral transmission. Bodily fluids will be tested by polymerase chain reaction (PCR). Fluids tested will include:

- Blood
- Saliva
- Semen
- Urine
- Stool

Vector shedding will also be extensively studied in the present clinical trial, at the time points indicated in [Table 9.1.1](#), [Table 9.1.2](#), [Table 9.1.3](#), [Table 9.1.4](#), and [Table 9.1.5](#). Testing will continue until at least 3 consecutive results below the limit of detection are obtained. If a positive result is obtained in a matrix after 3 consecutive results below the limit of detection have already been recorded, testing in that matrix should restart and continue until an additional 3 consecutive results below the limit of detection have been obtained in order to confirm clearance.

Testing of semen will continue at least through Week 12, even if 3 consecutive results below the limit of detection have been recorded in that compartment prior to that time point.

Subjects who have not had 3 consecutive semen samples below the limit of detection by Week 52 should continue to have PCR testing in semen every 4 weeks (during Year 2) and every 6 weeks (during Years 3-5) until 3 consecutive samples below the limit of detection are documented (or upon consultation between the Investigator and Medical Monitor).

Subjects who meet the definition of treatment failure and wish to follow an abbreviated schedule (refer to [Section 12.7](#)) but who have not cleared vector shedding from semen must

---

still provide samples for assessment every 4 weeks (during Year 2) or every 6 weeks (during Years 3-5) until vector shedding has cleared. Such subjects may provide samples on the designated study visit dates either at the sites or through use of a MN professional.

Samples may be fractionated prior to shedding analysis in order to better characterize the presence, structure, and location of vector DNA and/or vector capsid within each matrix. If needed, the fractionation may be performed with samples collected specifically for shedding analysis (saliva, blood, semen, urine, stool). Alternatively, the vector DNA characterization during shedding analysis may utilize already fractionated exploratory samples obtained from the above biofluids, such as exploratory plasma samples, exploratory PBMC samples, and red blood cells recovered during PBMC/plasma isolations.

Fractionation of semen to collect purified sperm separately from non-sperm cells may be performed in parallel at any visit where semen samples are collected. The shedding analysis of a fractionated semen sample will only be performed if vector DNA was detected in the whole semen sample for the same visit. Fractionation of semen during shedding analysis may be stopped if purified sperm tested positive for vector DNA on at least three visits, or if purified sperm tested negative for vector DNA on at least three consecutive visits.

Contraception use may need to be extended beyond 12 weeks in individual subjects based on observed vector shedding in semen. After 12 weeks, subjects may stop contraception use only if they have had 3 consecutive semen samples with viral vector DNA below the limit of detection (upon consultation between the Investigator and Medical Monitor).

Details for sample collection and storage are provided in the Laboratory Manual.

---

## 10 REPORTING ADVERSE EVENTS

### 10.1 Safety Parameters and Definitions

Safety assessments will consist of monitoring and recording protocol-defined AEs and SAEs; measurement of protocol-specified hematology, clinical chemistry, and urinalysis variables; measurement of protocol-specified vital signs; and other protocol-defined events of special interest that are deemed critical to the safety evaluation of the study drug.

#### 10.1.1 Adverse Events

For this protocol, an adverse event (AE) is any untoward medical occurrence in a subject, temporally associated with the use of study intervention, whether or not considered related to the study intervention.

An AE can therefore be any unfavorable and unintended sign (including an abnormal laboratory finding), symptom, or disease (new or exacerbated) temporally associated with the use of study intervention.

Events meeting the AE definition include:

- Exacerbation of a chronic or intermittent pre-existing condition including either an increase in frequency and/or intensity of the condition.
- New conditions detected or diagnosed after study intervention administration even though it may have been present before the start of the study.
- Signs, symptoms, or the clinical sequelae of a suspected drug-drug interaction.

Events not meeting the AE definition include:

- Any clinically significant abnormal laboratory findings or other abnormal safety assessments which are associated with the underlying disease, unless judged by the investigator to be more severe than expected for the subject's condition.
- The disease/disorder being studied or expected progression, signs, or symptoms of the disease/disorder being studied, unless more severe than expected for the subject's condition.
- Medical or surgical procedure (eg, endoscopy, appendectomy): the condition that leads to the procedure is the AE.
- Situations in which an untoward medical occurrence did not occur (social and/or convenience admission to a hospital).
- Anticipated day-to-day fluctuations of pre-existing disease(s) or condition(s) present or detected at the start of the study that do not worsen.

### 10.1.1.1 Bleeding and Suspected Bleeding Events

All bleeding events and suspected bleeding events, regardless of the need for exogenous FVIII therapy as treatment, should be captured in subject diaries and recorded on the designated bleeding eCRF. Bleeding events and suspected bleeding events should not be reported as adverse events, with the following exception:

- All bleeding events and suspected bleeding events which meet one or more of the criteria for being serious (refer to Section 10.2) should be reported as serious adverse events (whether or not they are bleeding events that are normal sequelae of hemophilia, and whether or not they required exogenous FVIII as treatment).

### 10.2 Serious Adverse Events

A serious adverse event (SAE) is any untoward medical occurrence that, at any dose:

- Results in death
- Is life-threatening

*Note: Life-threatening refers to an event in which the subject was at risk of death at the time of the event. It does not refer to an event, which hypothetically might have caused death, if it were more severe.*

- Requires inpatient hospitalization or prolongation of existing hospitalization

Note: In general, hospitalization signifies that the subject has been detained (usually involving at least an overnight stay) at the hospital or emergency ward for observation and/or treatment that would not have been appropriate in the physician's office or outpatient setting. If the investigational product preparation, infusion, and post-infusion observation period require transfer to an inpatient setting for completion, in the absence of an AE, this will not be considered an SAE.

Complications that occur during hospitalization are AEs. If a complication prolongs hospitalization, the event is serious.

Hospitalization for elective treatment of a pre-existing condition that did not worsen from baseline is not considered an AE.

- Results in persistent or significant disability or incapacity
- Is a congenital anomaly or birth defect in the child or fetus of a subject exposed to IP prior to conception or during pregnancy
- Is an important medical event or reaction – that, based on medical judgment, may jeopardize the subject or require medical/surgical intervention to prevent one of the other outcomes listed above (eg, anaphylaxis)



### 10.2.1 Events of Special Interest (EOSI)

The following EOSI need to be reported to the Sponsor within 24 hours of site awareness, irrespective of seriousness, severity or causality:

- Elevation of ALT > ULN or  $\geq 1.5x$  baseline value, regardless of whether that elevation triggers an initiation or modification of oral corticosteroid treatment
- Events potentially meeting the criteria for Hy's law (ALT or AST elevation  $\geq 3x$  ULN plus total bilirubin  $\geq 2x$  ULN)
- Thromboembolic event
- Systemic hypersensitivity, anaphylactic, or anaphylactoid reactions (refer to Appendix 1)
- Development of anti-FVIII inhibitory antibodies (inhibitors)

## 10.3 Methods and Timing for Capturing and Assessing Safety Parameters

### 10.3.1 Adverse Event Reporting Period

The study AE reporting period is as follows:

- After informed consent but prior to initiation of study drug, only SAEs associated with any protocol-imposed interventions will be collected. AEs occurring during this time period should be recorded on the Medical History eCRF.
- After informed consent is obtained and following infusion of study drug, the reporting period for all non-serious AEs and SAEs begins and continues for approximately 5 years or until study discontinuation/termination, whichever is longer.

The criteria for determining, and the reporting of SAEs is provided in Section [10.2](#).

### 10.3.2 Eliciting Adverse Events

Care will be taken not to introduce bias when detecting AEs and/or SAEs. Open-ended and non-leading verbal questioning of the subject is the preferred method to inquire about AE occurrences. The Investigator will record all relevant AE/SAE/EOSI information in the subject's medical record and AE Case Report Form (eCRF).

### 10.3.3 Assessment of Seriousness, Severity, and Causality

The Investigator responsible for the care of the subject or medically qualified designee will assess AEs for severity, relationship to study drug, and seriousness (refer to Section [10.2](#) for SAE definitions). These assessments must be made by a study clinician with the training and authority to make a diagnosis (eg, MD/DO, physician's assistant, nurse practitioner, or DDS).



### 10.3.3.1 Seriousness

The Investigator will assess if an AE should be classified as “serious” based on the seriousness criteria enumerated in Section 10.2. Seriousness serves as a guide for defining regulatory reporting obligations.

### 10.3.3.2 Severity

Severity (as in mild, moderate, or severe headache) is not equivalent to seriousness, which is based on subject/event outcome or action criteria usually associated with events that pose a threat to a subject’s life or functioning. The Investigator will determine the severity of each AE, SAE and EOSI using the NCI CTCAE v4.03. Adverse events that do not have a corresponding CTCAE term will be assessed according to the general guidelines for grading used in the CTCAE v4.03 as stated in Table 10.3.3.2.1.

**Table 10.3.3.2.1: Adverse Event Grading (Severity) Scale**

| Grade | Description  |   |
|-------|--|---|
| 1     | Mild: asymptomatic or mild symptoms; clinical or diagnostic observations only; intervention not indicated  |   |
| 2     | Moderate: minimal, local or noninvasive intervention indicated; limiting age-appropriate instrumental activities of daily living (ADL) <sup>a</sup>                                |   |
| 3     | Severe or medically significant but not immediately life-threatening; hospitalization or prolongation of hospitalization indicated; disabling; limiting self-care ADL <sup>b</sup> |   |
| 4     | Life threatening consequences; urgent intervention indicated   | Grade 4 and 5 AEs should always be reported as SAEs |
| 5     | Death related to AE  |   |

<sup>a</sup> Instrumental ADL refer to the following examples: preparing meals, shopping for groceries or clothes, using the telephone, managing money.

<sup>b</sup> Self-care ADL refer to the following examples: bathing, dressing and undressing, feeding oneself, using the toilet, taking medications, not bedridden.

### 10.3.3.3 Causality

The Investigator will determine the relationship of an AE to the study drug and/or corticosteroids and/or other immunosuppressant agents and will record it on the source documents and AE eCRF. To ensure consistency of causality assessments, Investigators should apply the guidance in Table 10.3.3.3.1.

**Table 10.3.3.3.1: Causality Attribution Guidance**

| Relationship | Description   |
|--------------|---|
| Not Related  | <ul style="list-style-type: none"> <li>• Exposure to the IP and/or corticosteroids and/or other immunosuppressant agents has not occurred</li> </ul> <p style="text-align: center;"><b>OR</b></p> <ul style="list-style-type: none"> <li>• The administration of the IP and/or corticosteroids and/or other immunosuppressant agents and the occurrence of the AE are not reasonably related in time</li> </ul> <p style="text-align: center;"><b>OR</b></p> <ul style="list-style-type: none"> <li>• The AE is considered likely to be related to an etiology other than the use of the IP and/or corticosteroids and/or other immunosuppressant agents; that is, there are no facts, evidence, or arguments to suggest a causal relationship to the IP and/or corticosteroids and/or other immunosuppressant agents.</li> </ul>   |
| Related      | <ul style="list-style-type: none"> <li>• The administration of the IP and/or corticosteroids and/or other immunosuppressant agents and the occurrence of the AE are reasonably related in time</li> </ul> <p style="text-align: center;"><b><u>AND</u></b></p> <ul style="list-style-type: none"> <li>• The AE could not possibly be explained by factors or causes other than exposure to the IP and/or corticosteroids and/or other immunosuppressant agents</li> </ul> <p style="text-align: center;"><b><u>OR</u></b></p> <ul style="list-style-type: none"> <li>• The administration of IP and/or corticosteroids and/or other immunosuppressant agents and the occurrence of the AE are reasonably related in time</li> </ul> <p style="text-align: center;"><b><u>AND</u></b></p> <ul style="list-style-type: none"> <li>• The AE is more likely explained by exposure to the IP and/or corticosteroids and/or other immunosuppressant agents than by other factors or causes</li> </ul> |

Factors suggestive of a causal relationship could include (but are not limited to):

- Plausible temporal relationship
- Absence of alternative explanations
- Rarity of event in a given patient or disease state

- Absence of event prior to study drug and/or corticosteroid and/or other immunosuppressant agent exposure
- Consistency with study product pharmacology
- Known relationship to underlying mechanism of study drug and/or corticosteroid and/or other immunosuppressant agent action
- Similarity to adverse reactions seen with related drug products
- Abatement of AE with discontinuation of study drug and/or corticosteroids and/or other immunosuppressant agents, and/or recurrence of AE with reintroduction of study drug and/or corticosteroids and/or other immunosuppressant agents

The Investigator's assessment of causality for individual AE reports is part of the study documentation process. Regardless of the Investigator's assessment of causality for individual AE reports, the Sponsor will promptly evaluate all reported SAEs against cumulative product experience to identify and expeditiously communicate possible new safety findings to Investigators and applicable regulatory authorities.

#### **10.4 Procedures for Recording Adverse Events**

##### **10.4.1 Recording Adverse Events on a eCRF**

Investigators should use precise medical terminology when recording AEs or SAEs on the AE eCRF. Avoid colloquialisms and abbreviations.

Record only one diagnosis, sign, or symptom per event field on the AE eCRF (eg, nausea and vomiting should not be recorded in the same entry, but as 2 separate entries).

In order to classify AEs and diseases, preferred terms will be assigned by the Sponsor to the original terms entered on the AE eCRF, using MedDRA (Medical Dictionary for Regulatory Activities) terminology.

##### **10.4.1.1 Diagnosis versus Signs and Symptoms**

The Investigator will attempt to establish a diagnosis of the event based on signs, symptoms, and/or other clinical information. Whenever possible, the diagnosis (not the individual signs/symptoms) will be documented as the AE/SAE. Using accepted medical terminology, enter the diagnosis (if known). If not known, enter sign(s) and/or symptom(s). If a diagnosis subsequently becomes available, then this diagnosis should be entered on the AE (or SAE, as appropriate) eCRF, replacing the original entries where appropriate.

#### 10.4.1.2 Adverse Events Occurring Secondary to Other Events

In general, AEs occurring secondary to other events (eg, cascade events) should be identified by their primary cause. For example, if severe diarrhea is known to have resulted in dehydration, it is sufficient to record only diarrhea as an AE or SAE on the AE eCRF. However, medically important events that may be linked and/or separated in time should be recorded as independent events on the AE eCRF. For example, if severe hemorrhage leads to renal failure, both events should be recorded separately on the AE eCRF.

#### 10.4.1.3 Persistent or Recurrent Adverse Events

A persistent AE (duration of adverse event > 7 days) is one that extends continuously, without resolution, between subject evaluation time points. Events that change in severity necessitate the recording of an additional AE. AEs that do not have a change in severity should be recorded only once on the eCRF.

A recurrent AE is one that occurs and resolves between subject evaluation time points, but then subsequently recurs. All recurrences of the AE should be recorded on the AE eCRF. For example, if a subject has an adverse event of ALT increased that subsequently resolves, but the subject's ALT increases again, that should be reported as two adverse events – the initial ALT increase, and the second ALT increase.

#### 10.4.1.4 Abnormal Laboratory Values

Laboratory test results will be recorded on the laboratory results pages of the eCRF, or appear on electronically produced laboratory reports submitted directly from the central laboratory, if applicable.

Any laboratory result abnormality fulfilling the criteria for a SAE or EOSI should be reported as such, and recorded in the AE eCRF.

Any laboratory result abnormality of CTCAE Grade 4 or 5 should be recorded as an SAE in the AE eCRF.

A clinical laboratory abnormality is considered clinically significant and should be documented as an AE if not refuted by a repeat test to confirm the abnormality and **any** one or more of the following conditions is met:

- Accompanied by clinical symptoms
- Requiring a change in concomitant therapy (eg, addition of, interruption of, discontinuation of, or any other change in a concomitant medication, therapy or treatment).

- The abnormality suggests a disease and/or organ toxicity
- The abnormality is of a degree that requires active management (eg, change of dose, discontinuation of study drug, more frequent follow-up assessments, further diagnostic investigation, etc.)

**This applies to** any protocol and non-protocol specified safety and efficacy laboratory result from tests performed after the first dose of study medication that falls outside the laboratory reference range and meets the clinical significance criteria.

**This does not apply to** any abnormal laboratory result that falls outside the laboratory reference range but that does not meet the clinical significance criteria (these will be analyzed and reported as laboratory abnormalities), those that are considered AEs of the type explicitly exempted by the protocol, or those which are a result of an AE that has already been reported.

For purposes of this study, laboratory tests showing a decreased level of FVIII activity should not be reported as adverse events unless there is an impact to clinical outcomes (eg, increased rate of bleeding, worsening of joint disease).

#### **10.4.1.5 Pre-existing Conditions**

A pre-existing condition is one that is present prior to administration of BMN 270. Such conditions should be recorded as medical history on the appropriate eCRF.

A pre-existing condition should be recorded as an AE or SAE during the study **only** if the frequency, intensity, or character of the condition worsens during the study period. It is important to convey the concept that a pre-existing condition has changed by including applicable language in the verbatim description of the event (eg, *more frequent* headaches).

#### **10.4.1.6 General Physical Examination Findings**

At screening, any clinically significant abnormality should be recorded as a pre-existing condition (refer to Section 10.4.1.5). During the study, any new clinically significant findings and/or abnormalities discovered on physical examination that meet the definition of an AE (or an SAE) must be recorded and documented as an AE or SAE on the AE eCRF.

#### **10.4.1.7 Hospitalization, Prolonged Hospitalization, or Surgery**

Any AE that results in hospitalization or prolonged hospitalization should be documented and reported as an SAE unless specifically instructed otherwise in this protocol (refer to Section 10.2).

There are some hospitalization scenarios that do not require reporting as an SAE when there is no occurrence of an AE. These scenarios include planned hospitalizations or prolonged hospitalizations to:

- Perform a protocol-mandated efficacy measurement
- Undergo a diagnostic or elective surgical procedure for a pre-existing medical condition that has not worsened
- Insert an in-dwelling IV catheter (such as a Port-a-Cath or other brand, if applicable) for administration of study drug or FVIII replacement therapy
- Receive scheduled therapy (study drug or otherwise) for the study indication

#### **10.4.1.8 Deaths**

All deaths that occur during the AE reporting period (refer to Section 10.3.1), regardless of attribution, will be recorded on the AE eCRF and expeditiously reported to the Sponsor as an SAE.

When recording a death, the event or condition that caused or contributed to the fatal outcome should be recorded as the single medical concept on the eCRF. If the cause of death is unknown and cannot be ascertained at the time of reporting, record “Unexplained Death” or “Death of Unknown Cause” on the AE eCRF.

#### **10.4.1.9 Pregnancy**

Although not an AE per se, pregnancy in the partner of a subject taking trial medication should be reported expeditiously to the Sponsor to facilitate outcome monitoring by the Sponsor. Pregnancy in partner should be reported during the period up to 5 years after viral infusion.

Pregnancy in a partner should be reported within 24 hours of the site becoming aware of the pregnancy by entering the information on the Pregnancy eCRF and submitting to BPV within 24 hours of the site becoming aware of the event. The Investigator must make every effort to follow the subject’s partner (with that partner’s consent) through resolution of the pregnancy (delivery or termination) and to report the resolution on the Pregnancy Follow-up eCRF. In the event of pregnancy in the partner of a study subject, the Investigator should make every reasonable attempt to obtain the woman’s consent for release of protected health information.

Abortion, whether therapeutic or spontaneous, should always be classified as an SAE (as the Sponsor considers these to be medically significant), recorded on the AE eCRF, and expeditiously reported to the Sponsor as an SAE.

## **10.5 Reporting Requirements**

### **10.5.1 Expedited Reporting Requirements**

All SAEs and EOSI that occur during the course of the AE Reporting Period (refer to Section 10.3.1), whether or not considered related to study drug, must be reported by entering the information in the AE eCRF and submitting to BPV within 24 hours of the site becoming aware of the event. Investigators should not wait to collect information that fully documents the event before notifying BPV of an SAE. BioMarin may be required to report certain SAEs to regulatory authorities within 7 calendar days of being notified about the event; therefore, it is important that Investigators submit any information requested by BioMarin as soon as it becomes available. IND safety reports will be submitted within 7 calendar days for fatal or life-threatening unexpected suspected adverse reactions (SUSARs) and within 15 calendar days for other non-life-threatening SUSARs

The Sponsor is responsible for identifying, preparing and reporting all SUSARs to the relevant competent authorities, ethics committees and Investigators in accordance with the requirements identified in the Clinical Trials Regulations.

If the EDC is unavailable, all SAEs should be reported to BPV by completing the SAE Report Form and faxing or emailing the completed form to BPV within 24 hours of the site becoming aware of the event. Once the EDC is available, the information should be entered in the AE eCRF.

### **10.5.2 Institutional Review Board or Independent Ethics Committee Reporting Requirements**

Reporting of SAEs to the Independent Ethics Committee (IEC) or Institutional Review Board (IRB) will be done in compliance with the standard operating procedures and policies of the IEC/IRB and with applicable regulatory requirements. Adequate documentation must be obtained by BioMarin showing that the IEC/IRB was properly and promptly notified as required.

## **10.6 Follow-up of Subjects after Adverse Events**

After the initial AE/SAE/EOSI report, the Investigator is required to proactively follow each subject at subsequent visits/contacts. All AEs/SAEs/EOSI will be followed until resolution, stabilization, the event is otherwise explained, or the subject is lost to follow-up. Resolution of AEs/SAEs/EOSI (with dates) should be documented on the AE eCRF and submitted to BioMarin Pharmacovigilance and in the subject's medical record to facilitate source data verification.



For some SAEs and EOSI, the Sponsor may follow up by telephone, fax, electronic mail, and/or a monitoring visit to obtain additional case details (eg, hospital discharge summary, consultant report, or autopsy report) deemed necessary to appropriately evaluate the SAE or EOSI report.

### **10.7 Post-Study Adverse Events**

At the last scheduled visit, the Investigator should instruct each subject to report, to the Investigator and/or to BPV directly, any subsequent SAEs that the subject's personal physician(s) believes might be related to prior study drug.

The Investigator should notify the study Sponsor of any death or SAE occurring at any time after a subject has discontinued or terminated study participation, if the Investigator believes that the death or SAE may have been related to prior study drug. The Sponsor should also be notified if the Investigator should become aware of the development of cancer or of a congenital anomaly in a subsequently conceived offspring of a subject that participated in this study.

### **10.8 Urgent Safety Measures**

The regulations governing clinical trials state that the Sponsor and Investigator are required to take appropriate urgent safety measures to protect subjects against any immediate hazards that may affect the safety of subjects, and that the appropriate regulatory bodies should be notified according to their respective regulations. According to the European Union (EU) Clinical Trial Directive 2001/20/EC, "...in the light of the circumstances, notably the occurrence of any new event relating to the conduct of the trial or the development of the investigational medicinal product where that new event is likely to affect the safety of the patients, the Sponsor and the Investigator shall take appropriate urgent safety measures to protect the patients against any immediate hazard. The Sponsor shall forthwith inform the competent authorities of those new events and the measures taken and shall ensure that the IRB/IEC/REB is notified at the same time."

The reporting period for these events which may require the implementation of urgent safety measures is the period from the time of signing of the ICF through the completion of the last study visit or at the Early Termination Visit (ETV). Investigators are required to report any events which may require the implementation of urgent safety measures to BioMarin within 24 hours.

Examples of situations that may require urgent safety measures include discovery of the following:



- Lack of study scientific value, or detrimental study conduct or management
- Discovery that the quality or safety of the IP does not meet established safety requirements

### 10.9 BioMarin Pharmacovigilance Contact Information

Contact information for BioMarin Pharmacovigilance is as follows:

BioMarin Pharmaceutical Inc.

Address 105 Digital Drive  
Novato, CA 94949  
Phone: +1 (415) 506-6179  
Fax: +1 (415) 532-3144  
E-mail: [drugsafety@bmrn.com](mailto:drugsafety@bmrn.com)

The Investigator is encouraged to discuss with the Medical Monitor any AEs for which the issue of seriousness is unclear or questioned. Contact information for the Medical Monitor is as follows:

Name: **PI** [redacted] MD, MSc, MBA  
Address: 105 Digital Drive  
Novato, CA 94949 USA  
Phone: **PI** [redacted]  
E-mail: **PI** [redacted]

## **11 APPROPRIATENESS OF MEASUREMENTS**

The measures of efficacy to be used in this study are standard, ie, widely used and generally recognized as reliable, accurate, and relevant (able to discriminate between effective and ineffective agents). The measures of safety used in this study are routine clinical and laboratory procedures.

The chromogenic substrate FVIII assay and the one-stage clotting FVIII assay are both validated and utilize CE marked reagents. The exploratory FVIII activity assay will be used for exploratory purposes only.

## 12 STUDY PROCEDURES

### 12.1 Prestudy

An ICF must be signed and dated by the patient, the Investigator or designee and witness (if required) before any study-related procedures are performed.

### 12.2 Screening Visit

Screening assessments should be performed within 28 days of BMN 270 infusion (and must be performed within 42 days prior to BMN 270 infusion), while baseline assessments will take place within 7 days prior to BMN 270 infusion (Day 1). Should the screening visit occur within 30 days of the drug infusion, physical examination, vital signs, blood chemistry, LTs, hematology, urine tests, and coagulation tests do not need to be repeated at Baseline.

The following procedures will be performed during the Screening Period:

- Demographics (age, sex, race, ethnicity)
- Full medical history, including hemophilia A history, Hepatitis B, Hepatitis C, and HIV. Subjects with a history of hepatitis B or hepatitis C will be asked for information about the treatments received. Any prior pharmacokinetics information obtained while the subject was receiving prophylactic or on-demand FVIII therapy prior to the study should also be collected.
- Complete Physical Examination
- Height and weight
- Vital Signs (systolic and diastolic blood pressure, heart rate, respiration rate, and temperature)
- Assessment of Adverse Events and Concomitant Medications
- Documentation of bleeding episodes and FVIII usage (by either subject or clinical information) for the previous 12 months
  - Further information on details to be included in documentation of previous bleeding episodes and FVIII usage, refer to the On Site File Binder.
- Distribution of subject diaries and training in diary completion
- Electrocardiogram
- Liver Ultrasound
- Samples for hFVIII Assays
  - Baseline FVIII activity – chromogenic substrate FVIII assay
  - Baseline FVIII activity level – one-stage clotting FVIII assay

- hFVIII coagulation activity exploratory assay (collected but not tested prior to enrollment)
- hFVIII inhibitors (Bethesda assay with Nijmegen modification)
- hFVIII total antibody assay (collected but not tested prior to enrollment)
- hFVIII protein assay (collected but not tested prior to enrollment)
- Blood sample for AAV5 total antibody (TAb) assay
- Screen for Hepatitis B, Hepatitis C, and HIV if required (subjects with documented negative results 30 days prior to informed consent being obtained do not need to be retested)
  - Hepatitis B screening should include HBsAg, HBsAb, and HBcAb.
- Blood chemistry, hematology, and coagulation tests (refer to [Table 9.7.8.2.1](#))
- Urine Tests (refer to [Table 9.7.8.2.1](#))
- Liver Tests (refer to [Table 9.7.8.3.1](#))
- Blood samples for Biomarker testing (including HLA genotyping and FVIII genotyping status)

### 12.2.1 “Smart Rescreening” Visit

Subjects who undergo smart rescreening must complete the rescreening assessments and receive the infusion within 90 days of signing the original consent. Subjects who do not complete dosing within 90 days will be required to re-consent and undergo all screening procedures. Subjects may not undergo smart rescreening more than once.

If a patient has to be screened again because the original assessments have fallen out of the 28 + 14 day period allowed for Screening (refer to Section [12.2](#)), then only the following assessments need to be performed (rather than the full list indicated in Section [12.2](#)) for the patient to be successfully re-screened for the study:

- Vital signs
- Assessment of Adverse Events and Concomitant Medications
- Documentation of bleeding episodes and FVIII usage (by either subject or clinical information)
- hFVIII Assays (only the hFVIII inhibitor level (Bethesda assay with Nijmegen modification))
- AAV5 Total Antibody assay
- Blood chemistry, hematology, and coagulation tests (refer to [Table 9.7.8.2.1](#))

- Urine Tests (refer to [Table 9.7.8.2.1](#))
- Liver Tests (refer to [Table 9.7.8.3.1](#))

### 12.3 Baseline Visit

Baseline values will be recorded from 1 to 7 days prior to the treatment visit. The following procedures will be performed during the Baseline Period:

- Brief physical examination
- Vital signs
- Assessment of Adverse Events and Concomitant Medications
- Documentation of bleeding episodes and FVIII usage (by either subject or clinical information)
- Blood sample for AAV5 TI assay
- Blood sample for AAV5 TAb assay
- Blood chemistry, hematology, and coagulation tests (refer to [Table 9.7.8.2.1](#))
  - ABO blood typing assessment should be performed at Baseline, or at another regularly scheduled visit prior to the end of the subject's participation in the study.
- Urine Tests (refer to [Table 9.7.8.2.1](#))
- Liver Tests (refer to [Table 9.7.8.3.1](#))
- Samples for hFVIII Assays
  - Baseline FVIII activity – chromogenic substrate FVIII assay
  - Baseline FVIII activity level – one-stage clotting FVIII assay
  - hFVIII coagulation activity exploratory assay
  - hFVIII inhibitors (Bethesda assay with Nijmegen modification)
  - hFVIII total antibody assay
  - hFVIII protein assay
- PBMC collection for CTL baseline
- Von Willebrand Factor Antigen (VWF:Ag)
- TGA Assay
- PCR of vector DNA in blood, saliva, urine, semen, and stools
- Exploratory biomarker assessments

- Haemo-QoL-A assessment
- EQ-5D-5L
- Hemophilia Activities List (HAL)
- Work Productivity and Activity Impairment plus Classroom Impairment Questions: Hemophilia Specific (WPAI+CIQ:HS) questionnaire
- Patient Reported Outcomes, Burdens, and Experiences (PROBE) questionnaire

#### **12.4 Treatment Visit/BMN 270 Infusion Visit (Day 1)**

There will be one treatment visit for each subject. Subjects will remain in the clinic for at least 8 hours for the BMN 270 Infusion Visit. The following procedures will be performed during the BMN 270 Infusion Visit:

- Brief physical examination
- Assessment of Adverse Events and Concomitant Medications
- AAV5 TAb Assay (sample collected pre-infusion for analysis)
- Fasting lipid panel (blood triglycerides, total cholesterol, HDL cholesterol, and LDL cholesterol) (sample collected pre-infusion)
  - Subjects will fast for at least 8 hours prior to pre-infusion laboratory sampling on the day of the infusion visit.
- BMN 270 Infusion
- Vital Signs
  - Vital signs will be recorded prior to BMN 270 infusion and then every 15 minutes ( $\pm$  5 minutes) during BMN 270 infusion. Following infusion, vital signs will be monitored every 1 hour ( $\pm$  5 minutes) for at least 8 hours during the subject's stay in the clinic.
- PCR of vector DNA in blood, saliva, urine, semen, and stools
  - Collection of samples for PCR testing should occur between 2 and 24 hours after the BMN 270 infusion has been completed

In case of hypersensitivity or adverse drug reaction, safety assessment, including physical examination and vital signs, will be done and additional blood samples will be collected within 1 hour of the hypersensitivity reaction (eg, tryptase, C3, C3a, C4, C5, C5a, and cytokine bead array, as well as possible additional exploratory testing) and samples for IgE and cytokine bead array (and possible additional exploratory testing) between 8-24 hours after the reaction, if possible. In addition, a blood sample should be taken 1 week after the hypersensitivity reaction for assessment of the cytokine bead array. In-patient observation

can be extended and additional blood samples can be collected if deemed necessary at the discretion of the Investigator and Medical Monitor.

### **12.5 BMN 270 Infusion Follow-Up Visits – Weeks 1-26**

After BMN 270 has been infused, subjects will return to the study site every week ( $\pm$  48 hours) during Weeks 1-26. For subjects who have enrolled in 270-301 following participation in 270-902, optional MN services or shortened lab draw-only site visits may be conducted for the visits at Week 5, Week 7, Week 9, Week 11, Week 13, Week 15, Week 17, Week 19, Week 21, Week 23, and Week 25. At visits not specifically designated for MN eligibility (ie, visits where the subject is intended to return to the site for assessment), MN services may be used if the subject is unable to attend the site to complete the study visit during the acceptable window for that visit, upon prior approval by the Medical Monitor and discussion between the Medical Monitor and Investigator. In the event that neither a lab-only visit or MN visit can be conducted, the site should telephone the subject to collect adverse event, concomitant medication, and diary data (bleeding events and FVIII usage).

During Year 1, subjects may consent to an optional liver biopsy. If such a procedure is planned, refer to Section [12.9](#) for assessments related to performing the liver biopsy.

At the Weeks 1-26 visits, the following procedures will be completed:

#### **12.5.1 Once per week (Weeks 1 through 26)**

The following procedures will be performed at one visit per week from Weeks 1 through 26:

- Brief physical examination (complete physical examination at Week 26)
  - For visits where a MN service is being used or a lab draw-only site visit is conducted, physical examination will not be performed.
- Assessment of Adverse Events and Concomitant Medications (including review of subject diary for bleeding and FVIII use)
  - For visits where a MN service is being used, the service will contact the subject via e-mail or phone call to collect information regarding adverse events, changes to concomitant medications, bleeding episodes, and FVIII use.
- Vital Signs
  - For visits where a MN service is being used or a lab draw-only site visit is conducted, vital signs will not be performed.
- Liver Tests (refer to [Table 9.7.8.3.1](#))

- LTs may be monitored more or less frequently (and in particular when ALT values are  $> \text{ULN}$  or  $\geq 1.5x$  baseline value) based on discussion between the Medical Monitor and the Investigator and review of subject data, but LTs will be monitored at least twice weekly during periods when a subject's ALT is  $\geq 3x$  ULN.
- Samples for FVIII Assays
  - FVIII activity level (chromogenic substrate FVIII assay)
  - FVIII activity level (one-stage clotting FVIII assay)
  - FVIII coagulation activity exploratory assay
  - Bethesda assay (with Nijmegen modification) for hFVIII inhibitor level
  - FVIII protein assay

#### 12.5.2 Week 1 – Day 4

On Day 4 of Week 1, the following procedures will be performed:

- Assessment of Adverse Events and Concomitant Medications (including review of subject diary for bleeding and FVIII use)
- PCR of vector DNA in blood, saliva, urine, semen, and stools
- Liver Tests (refer to [Table 9.7.8.3.1](#))

#### 12.5.3 Week 1 – Day 8

On Day 8, the following procedures will be performed, in addition to the weekly assessments required in Section [12.5.1](#):

- PCR of vector DNA in blood, saliva, urine, semen, and stools

#### 12.5.4 Every 2 Weeks (Week 2, 4, 6, 8, 10, 12, 14, 16, 18, 20, 22, 24, and 26)

At Weeks 2, 4, 6, 8, 10, 12, 14, 16, 18, 20, 22, 24, and 26 the following procedure will be performed:

- PBMC collection

#### 12.5.5 Weeks 2, 4, 10, 16, 22, and 26

At Weeks 2, 4, 10, 16, 22, and 26 the following procedure will be performed:

- Blood chemistry, hematology, and coagulation tests (refer to [Table 9.7.8.2.1](#))

#### 12.5.6 Weeks 2, 3, 4, 6, 8, 12, 16, 20, 24, and 26

At Weeks 2, 3, 4, 6, 8, 12, 16, 20, 24, and 26, the following procedure will be performed:



- PCR of vector DNA in blood, saliva, urine, semen, and stools
  - Collection to occur until at least 3 consecutive results below the limit of detection are obtained. Semen samples should continue to be collected and tested through Week 12, even if 3 consecutive results below the limit of detection in that compartment have been recorded prior to that time point.

#### **12.5.7 Weeks 4, 12, and 26**

At Weeks 4, 12, and 26, the following procedure will be performed:

- Haemo-QoL-A assessment
- EQ-5D-5L
- HAL
- WPAI+CIQ:HS
- PROBE

#### **12.5.8 Every 4 Weeks (Weeks 4, 8, 12, 16, 20, and 24) Plus Week 26**

At Weeks 4, 8, 12, 16, 20, 24, and 26, the following procedures will be performed:

- Weight (not performed at Week 26)
- FVIII antibody titer

#### **12.5.9 Every 8 Weeks (Weeks 8, 16, and 24)**

At Weeks 8, 16, and 24, the following procedures will be performed:

- AAV5 TAb assay
- AAV5 TI assay

#### **12.5.10 Weeks 6, 12, 16, 20, 24, and 26**

At Weeks 6, 12, 16, 20, 24, and 26, the following procedures will be performed:

- Exploratory biomarker assessments

#### **12.5.11 Weeks 12 and 26**

At Weeks 12 and 26, the following procedures will be performed:

- Urine Tests (refer to [Table 9.7.8.2.1](#))
- VWF:Ag

**12.5.12 Week 16**

At Week 16, the following procedure will be performed:

- Test for Hepatitis B and Hepatitis C reactivation (only in subjects with evidence of prior exposure to hepatitis B and/or hepatitis C)
  - Subjects who receive therapeutic oral corticosteroids prior to Week 16 do not need to complete the Week 16 reactivation assessment; instead, they will be tested for hepatitis B and hepatitis C reactivation at the time points listed in [Table 9.1.6](#).

**12.5.13 Week 20, 24, and 26**

At Week 20, 24, and 26, the following procedure will be performed:

- TGA Assay

**12.6 Post-Infusion Follow-Up – Weeks 27-52**

During Weeks 27-36, subjects will return to the study site weekly ( $\pm$  48 hours). During Weeks 37-52, subjects will return to the study site every 2 weeks (Week 38, 40, 42, 44, 46, 48, 50, and 52) ( $\pm$  1 week). For subjects who have enrolled in 270-301 following participation in 270-902, optional MN services or shortened lab draw-only site visits may be conducted at Week 27, Week 29, Week 30, Week 31, Week 33, Week 34, Week 35, Week 38, Week 42, Week 46, and Week 50. At visits not specifically designated for MN eligibility (ie, visits where the subject is intended to return to the site for assessment), MN services may be used if the subject is unable to attend the site to complete the study visit during the acceptable window for that visit, upon prior approval by the Medical Monitor and discussion between the Medical Monitor and Investigator. In the event that neither a lab-only visit or MN visit can be conducted, the site should telephone the subject to collect adverse event, concomitant medication, and diary data (bleeding events and FVIII usage).

During Year 1, subjects may consent to an optional liver biopsy. If such a procedure is planned, refer to Section [12.9](#) for assessments related to performing the liver biopsy.

At these visits, the following procedures will be completed:

**12.6.1 Every Visit**

At every visit (Weeks 27-36, 38, 40, 42, 44, 46, 48, 50, and 52), the following procedures will be performed:

- Physical examination
  - Brief physical examination should be performed at all weeks except Week 26, when a complete physical examination should be performed
  - For visits where a MN service is being used or a lab draw-only site visit is conducted, physical examination will not be performed.
- Assessment of Adverse Events and Concomitant Medications (including review of subject diary for bleeding and FVIII use)
  - For visits where a MN service is being used, the service will contact the subject via e-mail or phone call to collect information regarding adverse events, changes to concomitant medications, bleeding episodes, and FVIII use.
- Vital Signs
  - For visits where a MN service is being used or a lab draw-only site visit is conducted, vital signs will not be performed.
- Liver Tests (refer to [Table 9.7.8.3.1](#))
  - LTs may be monitored more or less frequently (and in particular when ALT values are  $> \text{ULN}$  or  $\geq 1.5x$  baseline value) based on discussion between the Medical Monitor and the Investigator and review of subject data, but LTs will be monitored at least twice weekly during periods when a subject's ALT is  $\geq 3x \text{ ULN}$ .
- FVIII Assays
  - FVIII activity level (chromogenic substrate FVIII assay)
  - FVIII activity level (one-stage clotting FVIII assay)
  - FVIII coagulation activity exploratory assay
  - Bethesda assay (with Nijmegen modification) for FVIII inhibitor level
  - FVIII protein assay

#### **12.6.2 Weeks 28, 32, 36, 44, and 52**

At Weeks 28, 32, 36, 44, and 52, the following procedure will be performed:

- PBMC collection

#### **12.6.3 Every 4 Weeks (Weeks 28, 32, 36, 40, 44, 48, 52)**

At Weeks 28, 32, 36, 40, 44, 48, and 52, the following procedure will be performed:

- Weight

**12.6.4 Weeks 32, 36, 44, and 52**

At Weeks 32, 36, 44, and 52, the following procedures will be performed:

- Blood chemistry, hematology, and coagulation tests (refer to [Table 9.7.8.2.1](#))
- FVIII antibody titer

**12.6.5 Weeks 32, 36, 40, 44, 48, and 52**

At Weeks 32, 36, 40, 44, 48, and 52, the following procedures will be performed:

- Exploratory biomarker assessments
- TGA Assay
- PCR of vector DNA in blood, saliva, urine, semen, and stools
  - Sample testing to occur until at least 3 consecutive sample results below the limit of detection have been obtained. Subjects who have not had 3 consecutive semen samples below the limit of detection by Week 52 should continue to have PCR testing of semen every 4 weeks until 3 consecutive samples below the limit of detection are documented (or upon consultation between the Investigator and Medical Monitor).

**12.6.6 Week 32, 36, and 52**

At Week 32, 36, and 52, the following procedure will be performed:

- AAV5 TAb Assay
- AAV5 TI Assay

**12.6.7 Week 36 and 52**

At Weeks 36 and 52, the following procedures will be performed:

- Urine Tests (refer to [Table 9.7.8.2.1](#))
- VWF:Ag

**12.6.8 Week 52**

At Week 52, the following procedures will be performed:

- Haemo-QoL-A assessment
- EQ-5D-5L
- HAL
- WPAI+CIQ:HS
- PROBE

At Week 52, the following optional procedure may be performed:

- Optional liver biopsy (refer to Section 12.9 for assessments related to liver biopsy)

### **12.7 Post-Infusion Follow-Up – Years 2-5**

During Years 2-5, at applicable sites, certain study assessments may be performed by a mobile nursing (MN) professional at the patient's home or another suitable location, such as their school or office, to improve access and convenience for patients participating in the study. The Sponsor may select a healthcare company that will be responsible for providing MN services for participating sites (the MN vendor). The MN vendor is responsible for ensuring that all MN professionals are licensed, qualified, and in good standing, as per applicable regulations, and that appropriate background checks have been performed. If the investigator at a participating site determines that MN services are appropriate for a patient and the patient gives written informed consent to participate in MN visits, the MN network will communicate with the patient and the patient's site. MN visits will be allowed for the Q4W (during Year 2) and Q6W (during Years 3-5) visits; the Q12W visits and End of Year visits during Years 2-5 will not be performed by an MN professional but will be done at the study site. At visits not specifically designated for MN eligibility (ie, visits where the subject is intended to return to the site for assessment), MN services may be used if the subject is unable to attend the site to complete the study visit during the acceptable window for that visit, upon prior approval by the Medical Monitor and discussion between the Medical Monitor and Investigator.

Subjects who do not respond to BMN 270 treatment (ie, treatment failure, manifesting as either failure to achieve FVIII activity  $\geq 5$  IU/dL by Week 52 or inability to maintain independence from prophylactic FVIII replacement therapy due to joint bleeding episodes, in the judgment of the Investigator) may, at the Investigator's discretion and after discussion with the Medical Monitor or Sponsor-designated Data Monitor, follow an abbreviated visit schedule after Week 52 of the study by attending only the Q12W and End of Year visits during Years 2-5. Subjects who are not attending the Q4W/Q6W visits during Years 2-5 may receive a scheduled monthly follow-up telephone call from the site to ask about adverse events, concomitant medications, and bleeding events/FVIII replacement usage.

Subjects who meet the definition of treatment failure and wish to follow an abbreviated schedule but who have not cleared vector shedding from all fluids must still provide samples for assessment every 4 weeks (during Year 2) or every 6 weeks (during Years 3-5) until vector shedding has cleared. Such subjects may provide samples on the designated study visit dates either at the sites or through use of a MN professional.

During Years 2-5 of Post-Infusion Follow-up, the following procedures will be completed:

### 12.7.1 Year 2 – Every 4 Weeks (not required for treatment failure)

During Year 2, every 4 weeks ( $\pm 2$  weeks), the following procedures will be performed:

- Assessment of Adverse Events and Concomitant Medications (including review of subject diary for bleeding and FVIII use)
- Liver Tests (refer to [Table 9.7.8.3.1](#))
  - LTs may be monitored more or less frequently (and in particular when ALT values are  $> \text{ULN}$  or  $\geq 1.5x$  baseline value) based on discussion between the Medical Monitor and the Investigator and review of subject data, but LTs will be monitored at least twice weekly during periods when a subject's ALT is  $\geq 3x$  ULN.
- FVIII Assays
  - FVIII activity level (chromogenic substrate FVIII assay)
  - FVIII activity level (one-stage clotting FVIII assay)
  - FVIII coagulation activity exploratory assay
  - Bethesda assay (with Nijmegen modification) for FVIII inhibitor level
  - FVIII protein assay
- PCR of vector DNA in semen (if required)
  - Subjects who have not had 3 consecutive semen samples below the limit of detection by Week 52 should continue to have PCR testing of semen every 4 weeks during Year 2 until 3 consecutive samples below the limit of detection are documented (or upon consultation between the Investigator and Medical Monitor).
  - Subjects who meet the definition of treatment failure and wish to follow an abbreviated schedule but who have not cleared vector shedding in semen must still provide semen samples for assessment every 4 weeks during Year 2 until vector shedding has cleared. Such subjects may provide samples on the designated study visit dates either at the sites or through use of a MN professional.

### 12.7.2 Years 3-5 – Every 6 Weeks (not required for treatment failure)

During Years 3-5, every 6 weeks ( $\pm 2$  weeks), the following procedures will be performed:

- Assessment of Adverse Events and Concomitant Medications (including review of subject diary for bleeding and FVIII use)

- Liver Tests (refer to [Table 9.7.8.3.1](#))
  - LTs may be monitored more or less frequently (and in particular when ALT values are  $> \text{ULN}$  or  $\geq 1.5x$  baseline value) based on discussion between the Medical Monitor and the Investigator and review of subject data, but LTs will be monitored at least twice weekly during periods when a subject's ALT is  $\geq 3x$  ULN.
- FVIII Assays
  - FVIII activity level (chromogenic substrate FVIII assay)
  - FVIII activity level (one-stage clotting FVIII assay)
  - FVIII coagulation activity exploratory assay
  - Bethesda assay (with Nijmegen modification) for FVIII inhibitor level
    - If a subject tests positive in the Bethesda assay (with Nijmegen modification) during Years 3-5, a fresh sample should be collected within 4 weeks of the initial visit that had a positive result.
  - FVIII protein assay
- PCR of vector DNA in semen (if required)
  - Subjects who have not had 3 consecutive semen samples below the limit of detection by the end of Year 2 should continue to have PCR testing of semen every 6 weeks during Years 3-5 until 3 consecutive samples below the limit of detection are documented (or upon consultation between the Investigator and Medical Monitor).
  - Subjects who meet the definition of treatment failure and wish to follow an abbreviated schedule but who have not cleared vector shedding in semen by the end of Year 2 must still provide semen samples for assessment every 6 weeks during Years 3-5 until vector shedding has cleared. Such subjects may provide samples on the designated study visit dates either at the sites or through use of a MN professional.

### **12.7.3 Years 2-5 – Every 12 Weeks and End of Year Visits (required for all subjects)**

During Years 2-5, subjects will be asked to return to the study site for visits at the following study weeks ( $\pm 2$  weeks):

- Year 2 – Week 64, Week 76, Week 88, Week 104
- Year 3 – Week 116, Week 128, Week 140, Week 156
- Year 4 – Week 168, Week 180, Week 192, Week 208
- Year 5 – Week 220, Week 232, Week 244, Week 260

For each of these years, the last study visit listed (Week 104, Week 156, Week 208, and Week 260) will serve as an End of Year visit. The every 12 week and End of Year visits may not be performed remotely by MN services.

At the every 12 week and End of Year visits, the following procedures will be performed:

- Physical examination
  - Complete physical examination will be performed at the End of Year visits; brief physical examination may be performed at other visits.
- Weight (at Week 76, Week 128, Week 180, Week 232, and End of Year visits only)
- Assessment of Adverse Events and Concomitant Medications (including review of subject diary for bleeding and FVIII use)
- Liver Tests (refer to [Table 9.7.8.3.1](#))
  - LTs may be monitored more or less frequently (and in particular when ALT values are  $> \text{ULN}$  or  $\geq 1.5x$  baseline value) based on discussion between the Medical Monitor and the Investigator and review of subject data, but LTs will be monitored at least twice weekly during periods when a subject's ALT is  $\geq 3x \text{ ULN}$ .
- FVIII Assays
  - FVIII activity level (chromogenic substrate FVIII assay)
  - FVIII activity level (one-stage clotting FVIII assay)
  - FVIII coagulation activity exploratory assay
  - Bethesda assay (with Nijmegen modification) for FVIII inhibitor level
    - If a subject tests positive in the Bethesda assay (with Nijmegen modification) during Years 3-5, a fresh sample should be collected within 4 weeks of the initial visit that had a positive result.
  - FVIII protein assay
- Blood chemistry, hematology, and coagulation tests (refer to [Table 9.7.8.2.1](#)) (at Week 76, Week 128, Week 180, Week 232, and End of Year visits only)
- Urine Tests (refer to [Table 9.7.8.2.1](#)) (at Week 76, Week 128, Week 180, Week 232, and End of Year visits only)
- Vital Signs
- AAV5 TAb Assay
- AAV5 TI Assay
- FVIII antibody titer



- Haemo-QoL-A assessment (at Week 76, Week 128, Week 180, Week 232, and End of Year visits only)
- EQ-5D-5L (at Week 76, Week 128, Week 180, Week 232, and End of Year visits only)
- HAL (at Week 76, Week 128, Week 180, Week 232, and End of Year visits only)
- WPAI+CIQ:HS (at Week 76, Week 128, Week 180, Week 232, and End of Year visits only)
- PROBE (at Week 76, Week 128, Week 180, Week 232, and End of Year visits only)
- Exploratory biomarker assessments
- PBMC collection
- VWF:Ag
- TGA Assay
- PCR of vector DNA in blood, saliva, urine, semen, and stools (if required)
  - Sample testing during Years 2-5 is not required in a matrix if at least 3 consecutive samples are below the limit of detection in that matrix during the Post-Infusion Follow-Up period in Weeks 1-52.
- Optional liver biopsy (Years 2-5) (refer to Section 12.9 for assessments related to liver biopsy)

## 12.8 Early Termination Visit

The Early Termination visit will occur on the date the subject withdraws from the study, even if the date does not correspond to a protocol-specific visit.

If a subject leaves the study prior to the Week 260 visit, the subject will be asked to return to the study site and complete an Early Termination visit. At the Early Termination visit, as many of the following assessments as possible should be done:

- Physical examination
- Weight
- Assessment of Adverse Events and Concomitant Medications (including review of subject diary for bleeding and FVIII use)
- Vital Signs
- Blood chemistry, hematology, and coagulation tests (refer to [Table 9.7.8.2.1](#))
- Urine Tests (refer to [Table 9.7.8.2.1](#))
- Liver Tests (refer to [Table 9.7.8.3.1](#))

- FVIII Assays
  - FVIII activity level (chromogenic substrate FVIII assay)
  - FVIII activity level (one-stage clotting FVIII assay)
  - FVIII coagulation activity exploratory assay
  - Bethesda assay (with Nijmegen modification) for FVIII inhibitor level
  - FVIII protein assay
- AAV5 TAb Assay
- AAV5 TI Assay
- FVIII antibody titer
- Exploratory biomarker assessments
- PBMC collection
- VWF:Ag
- TGA Assay
- PCR of vector DNA in blood, saliva, urine, semen, and stools
  - Sample testing at the ETV is not required if at least 3 consecutive samples were clear during the Post-Infusion Follow-Up period.
- Haemo-QoL-A assessment
- EQ-5D-5L
- HAL
- WPAI+CIQ:HS
- PROBE

## 12.9 Optional Liver Biopsy

Details on required procedures for the optional liver biopsy are outlined in [Table 9.1.7](#). Subjects may be asked to provide a liver biopsy during Year 1, at or around Week 52, and during the Years 2-5 period post-BMN 270 infusion.

Subjects consenting to participate to the optional liver biopsy will undergo pre-biopsy assessments at least 28 days before the procedure, as follows:

- Liver ultrasound (subject should fast at least 8 hours prior to ultrasound)
- Physical examination
- Hematology, coagulation, chemistry assessments

- Liver tests
- FibroScan

Subjects consenting to participate to the optional liver biopsy will undergo pre-biopsy assessments at least 7 days before the procedure, as follows:

- FVIII activity level assessment (central and local)
- Exploratory CK18 and Grp78 assessment
- Pre-biopsy consultation (with hepatologist and/or radiologist)

On the day of the biopsy, brief physical examination and liver and blood tests should be performed before the procedure (including hematology, coagulation, and chemistry). FVIII activity assessment should also be performed to ensure the subject has sufficient FVIII activity to protect against procedure-related bleeding (as discussed above). LT assessment and a whole blood draw for PBMC collection should be performed on the biopsy day or  $\pm$  1 week from the biopsy day.

The optional liver biopsy should be performed in the morning if feasible, and the biopsy procedure and follow-up care should be done according to the local standard of care. Additional details for handling the biopsy specimens are provided in the Laboratory Manual.

Following completion of the biopsy, the subject should remain under observation in the clinic for at least 4-6 hours. Overnight post-procedure observation may be done at the investigator's discretion and/or according to local guidelines.

### **12.10 End of Study**

The study will end after the last subject yet to complete the last Long-Term Follow-Up visit (Week 260) does so, has transferred to another BMN 270 study, is withdrawn from the study, or discontinues from the study. BioMarin reserves the right to discontinue the study any time for clinical or administrative reasons and to discontinue participation of an individual Investigator or site for clinical or administrative reasons, including, but not limited to, poor enrollment or noncompliance with procedures of the protocol or GCP. In addition, the study may be terminated if, in the opinion of BioMarin, the safety of the study subjects may be compromised.

### **13 DATA QUALITY ASSURANCE**

BioMarin personnel or designees will visit the study site prior to initiation of the study to review with the site personnel information about the IP, protocol and other regulatory document requirements, source document requirements, eCRFs, monitoring requirements, and procedures for reporting AEs, including SAEs.

At visits during and after the study, a CRA will monitor the site for compliance with regulatory documentation, with a focus on accurate and complete recording of data on eCRFs from source documents, adherence to protocol, randomization (if applicable), SAE reporting and drug accountability records.

Data quality control and analysis will be performed by BioMarin or a designee, based on a predefined analysis plan.

## 14 STATISTICAL METHODS AND DETERMINATION OF SAMPLE SIZE

### 14.1 Statistical and Analytical Plans

The statistical analysis plan (SAP) will provide additional details on the planned statistical analysis. Unless otherwise stated, all analyses will be performed using SAS.

#### 14.1.1 Interim Analyses

Two interim analyses were planned, after approximately 16 and 20 treated HIV-negative subjects, respectively, completed the Week 26 visit (or have discontinued study participation prior to Week 26). The first interim analysis was performed as planned in May 2019. Based on the interim results and the totality of the data, the secondary interim analysis was deemed unnecessary. The DMC reviewed the interim analysis results to assess the efficacy and safety profiles, whether the pre-specified criteria of statistical significance has been achieved, and the risk/benefit ratio of the interventions in the BMN 270 studies based on the totality of the data.

The primary efficacy endpoint for the interim analyses involves hFVIII activity, as measured by chromogenic substrate assay, achieved post-BMN 270 infusion.

The fallback procedure ([Wiens, 2005](#)) will be used to adjust for multiplicity of the two interim analyses at Week 26 and the final analysis at Week 52 (regardless of the interim analyses results, the study is planned to continue upon the DMC's recommendation, and the final analysis will be performed at Week 52). At the final analysis at Week 52, the secondary efficacy endpoints will be tested hierarchically; the level of significance will be determined by the fallback procedure.

The secondary and tertiary endpoints will be summarized descriptively at the interim (Week 26) analyses.

The details of the interim analyses, including the control of Type I error rate, will be specified in the SAP.

#### 14.1.2 Procedures for Accounting for Missing, Unused and Spurious Data

Because the completeness of the data affects the integrity and accuracy of the final study analysis, every effort should be made to ensure complete, accurate, and timely data collection and, therefore, avoid missing data.

Missing data imputation and sensitivity analyses to assess the impact of missing data on the primary and secondary efficacy endpoints analyses are described in the following sections. Additional details regarding the handling of missing data will be provided in the SAP.

## 14.2 Primary Efficacy Endpoint

For the primary efficacy endpoint at Week 52 (ie, the change in the hFVIII activity during Weeks 49-52 post-BMN 270 infusion from baseline, as measured by chromogenic substrate assay), a one-sample t-test will be used to test the null hypothesis that the change is 0 or less against the alternative hypothesis that the change is greater than 0. Descriptive summaries of the proportions of subjects whose FVIII activity during Weeks 49-52 is greater than or equal to select thresholds, such as 15, 25 and 30 IU/dL, and the confidence intervals of the proportions will also be provided.

For a subject with a missing value of the primary endpoint, the median value in the subject's last 4-week window containing a valid observation will be used. Additional analyses will be conducted to examine the sensitivity of the results to the handling of missing data, including analysis using observed cases, and a mixed model for repeated measures (MMRM) approach. Further detail will be provided in the SAP.

The analyses for the primary endpoint will be performed using the analysis populations as defined in Section 14.9.

## 14.3 Secondary Efficacy Endpoints

The primary analyses for the secondary endpoints will be performed on the 110 subjects in the mITT population who will be followed up for approximately 6 months in the non-interventional study 270-902 prior to their enrollment in 270-301. The baseline values will be derived from the prospectively collected data in 270-902.

For the first secondary efficacy endpoint at Week 52 (ie, the change in the annualized utilization (IU/kg) of exogenous FVIII replacement therapy during Weeks 5-52 post-BMN 270 infusion from baseline), a one-sample t-test will be performed to test the null hypothesis that the change is 0 or greater against the alternative hypothesis that the change is less than 0. The missing value of the change will be imputed as 0.

For the second secondary efficacy endpoint at Week 52 (ie, the change in ABR, annualized bleeding rate, during Weeks 5-52 post-BMN 270 infusion from baseline), a one-sample t-test will be performed to test for non-inferiority of BMN 270 against FVIII prophylaxis (ie, the baseline ABR calculated using subjects' data collected as part of 270-902) using a non-inferiority margin of 3.5, ie, to test the null hypothesis that the change is 3.5 or greater against the alternative hypothesis that the change is less than 3.5. If non-inferiority is demonstrated, the test for superiority of BMN 270 against FVIII prophylaxis will be performed. The missing value of the change will be imputed using the median value of the changes of all observed cases.

A sensitivity analysis is planned to analyze ABR using a generalized linear mixed model assuming negative binomial as the underlying distribution. The model will include period (pre- to post-BMN 270 infusion) as the only factor. The actual number of bleeding episodes will be used as the dependent variable with the time period adjustment (annualization) being implemented as the offset.

To assess the impact of missing data, analyses using observed case are planned as sensitivity analyses for the secondary endpoints. Multiple imputation methods may also be performed.

The primary and secondary efficacy hypotheses will be tested hierarchically according to the order described above. Multiple comparison procedures will be described in greater detail in the SAP.

#### **14.4 Liver Biopsy Substudy Analysis**

A separate report presenting and discussing analyses of the exploratory objectives for the optional liver biopsy substudy will be prepared.

#### **14.5 Immunogenicity**

Analysis of total and neutralizing antibody response and other immunological parameters will be primarily descriptive and involve both inter-subject and intra-subject comparisons.

#### **14.6 Pharmacodynamic Analyses**

Plasma FVIII protein concentrations and FVIII activities determined over the course of the study will primarily be evaluated and summarized with descriptive statistical measures (eg, mean, standard deviation, CV%, min, median, max).

#### **14.7 Safety Analysis**

The Medical Dictionary for Regulatory Activities terminology (MedDRA) will be used by the Sponsor to assign system organ class and preferred term classification to events and diseases, based on the original terms entered on the eCRF.

All AEs will be coded using the current version of MedDRA. The incidence of AEs will be summarized by system organ class, preferred term, relationship to study drug, and severity. A by-subject listing will be provided for those subjects who experience a serious AE (SAE), including death, or experience an AE associated with early withdrawal from the study or study drug.

Clinical laboratory data will be summarized by the type of laboratory test. For each clinical laboratory test, descriptive statistics will be provided on Baseline as well as all subsequent

visits. Descriptive statistics for physical examination results and vital signs will also be provided.

Detailed statistical methods will be provided in the SAP.

#### **14.8 Determination of Sample Size**

Approximately one hundred and thirty (130) subjects may be dosed in the study. The sample size for this study is based on clinical and statistical considerations in order to provide sufficient data to assess both safety and efficacy of BMN 270.

For the primary endpoint, a sample size of 130 will provide at least 95% power to demonstrate that the change in hFVIII activity during Weeks 49-52 from baseline is greater than 0, assuming an effect size of 0.6, using a one-sample t-test with a 2-sided significance level of 0.05. The effect size of 0.6 is assumed based on Study 270-201 data. In Study 270-201 cohort 6E13, the mean (SD) of FVIII activity (IU/dL) at Week 52 (based on median values in a 4-week window around Week 52) were estimated as 103.8 (62.4), with a 95% confidence interval for the mean of (46.1, 161.5). Using the lower limit of the confidence interval and assuming a baseline value of 1 (the largest value allowed per the study's inclusion/exclusion criteria), the effect size of change from baseline is approximately 0.7. For the sample size calculation, an effect size of 0.6 is assumed.

For the secondary endpoints, the analysis will be performed utilizing exogenous FVIII use and bleeding episode data from the 110 subjects whose baseline data will be prospectively collected for approximately 6 months in the non-interventional study 270-902, prior to their enrollment in Study 270-301. An analytic sample size of 110 will provide at least 95% power to demonstrate that the change in the annualized utilization (IU/kg) of exogenous FVIII replacement therapy during Week 5 to Week 52 post-BMN 270 infusion from the baseline is less than 0, assuming an effect size of 0.6 conservatively, using one-sample t-test with a 2-sided significance level of 0.05.

For the analytic sample size calculation of the second secondary endpoint, ABR, it is assumed that the pre- and post-BMN 270 infusion population mean ABRs are 3.5 and 1 respectively, and the distribution of ABRs is negative binomial distribution with a dispersion parameter of 2.2. Given the underlying negative binomial distributions, the standard deviations of the pre- and post-BMN 270 infusion ABRs are calculated as 7.8 and 1.8 respectively. The mean (SD) of the change from the pre- to post-BMN 270 infusion ABRs are calculated as -2.5 (8) assuming the correlation between pre- and post-BMN 270 infusion ABRs is zero. Under this assumption, an analytic sample size of 110 will also have at least 95% power to demonstrate that the change in the annualized number of bleeding



episodes requiring exogenous FVIII replacement treatment (ABR) during Week 5 to Week 52 of the study post-BMN 270 infusion from the baseline ABR is less than 3.5 (non-inferiority margin), using a one-sample t-test with a 2-sided significance level of 0.05. Under the same assumptions, a sample size of 110 will have approximately 90% power to demonstrate that the change is less than 0, ie, superiority of BMN 270 against FVIII prophylaxis.

Overall, the planned sample size will have greater than 80% power for testing the primary and secondary efficacy endpoints hierarchically at the final analysis with a 2-sided significance level of 0.05.

#### **14.9 Analysis Populations**

The intention-to-treat (ITT) population is defined as all subjects who receive BMN 270 infusion, and the modified intention-to-treat (mITT) population is defined as subjects who receive BMN 270 infusion and are HIV-negative. The mITT population will be used for the primary efficacy analysis and ITT will be used for the supportive efficacy analysis. The ITT population will also be used for the safety analysis.

#### **14.10 Changes in the Conduct of the Study or Planned Analyses**

Only BioMarin may modify the protocol. Any change in study conduct considered necessary by the Investigator will be made only after consultation with BioMarin, who will then issue a formal protocol amendment to implement the change. The only exception is when an Investigator considers that a subject's safety is compromised without immediate action. In these circumstances, immediate approval of the chairman of the IRB/IEC/REB must be sought, and the Investigator should inform BioMarin and the full IRB/IEC/REB within 2 working days after the emergency occurs.

With the exception of minor administrative or typographical changes, the IRB/IEC/REB must review and approve all protocol amendments. Protocol amendments that have an impact on subject risk or the study objectives, or require revision of the ICF, must receive approval from the IRB/IEC/REB prior to their implementation.

When a protocol amendment substantially alters the study design or the potential risks or burden to subjects, the ICF will be amended and approved by BioMarin and the IRB/IEC/REB, and all active subjects must again provide informed consent.

**15 DATA MONITORING COMMITTEE**

An independent DMC will be convened for this study. The duties of the DMC will include:

- Conducting an ongoing review of individual subject safety and efficacy data during the study.
- Recommending whether to enroll subjects at a different dose level (not to exceed 6E13 vg/kg) based on emerging data from 270-301 and the overall risk/benefit analysis of BMN 270.
- Reviewing ongoing safety and efficacy data for comparability of drug manufacturing lots within 270-301 and between 270-201 and 270-301.
- Making other recommendations on the conduct and reporting of the trial based on their evaluation of clinical data.

Details on the composition of the committee, frequency of meetings, and other committee functions and parameters are included in the DMC Charter and in the Statistical Analysis Plan (SAP).

**16 COSTS, COMPENSATION, AND SUBJECT INJURY**

BioMarin will pay the full costs of the study-related tests, procedures, and treatments set forth in this protocol. In addition, after IRB/IEC/REB approval, BioMarin may reimburse the reasonable cost of travel for study-related visits in accordance with BioMarin's travel and reimbursement policy.

The Investigator should contact BioMarin immediately upon notification that a study subject has been injured by the study drug or by procedures performed as part of the study.

Any subject who experiences a study-related injury should be instructed by the Investigator to seek immediate medical treatment at a pre-specified medical institution if possible, or at the closest medical treatment facility if necessary. The subject should be given the name of a person to contact to seek further information about, and assistance with, treatment for study-related injuries. BioMarin or the institution may pay for reasonable and necessary medical services to treat the injuries caused by the study drug or study procedures. In some jurisdictions, BioMarin is obligated by law to pay for study-related injuries. If this is the case, BioMarin will comply with the law. BioMarin will not pay for any hospitalizations, tests, or treatments for medical problems of any sort related solely to the study subject's primary disease or any concurrent disease and that are unrelated to this study.

---

## 17 CASE REPORT FORMS AND SOURCE DOCUMENTS

Electronic case report forms will be provided for each subject. The Investigator must review and electronically sign the completed eCRF casebook to verify its accuracy.

eCRFs must be completed using a web-based application developed and validated. Study site personnel will be trained on the application and will enter the clinical data from source documentation. Unless explicitly allowed in the eCRF instructions, blank data fields are not acceptable.

In the event of an entry error, or if new information becomes available, the value will be corrected by deselecting the erroneous response and then selecting or entering the factual response. In compliance with ICH GCP Guidelines and 21 CFR Part 11, the system will require the personnel making the correction to enter a reason for changing the value.

The documented audit trail will include the reason for the change, the original value, the new value, the time of the correction and the identity of the operator.

BioMarin's policy is that study data on the eCRFs must be verifiable to the source data, which necessitates access to all original recordings, laboratory reports, and subject records. In addition, all source data should be attributable (signed and dated). The Investigator must therefore agree to allow direct access to all source data. Subjects must also allow access to their medical records, and subjects will be informed of this and will confirm their agreement when giving informed consent. If direct source document verification of study data by the site monitor is prohibited by institutional policy or local law, then the Investigator must make available facilities and/or personnel to allow GCP-compliant source verification to occur. Examples of such methods include certified copies of records which have study data visible but sensitive information redacted, or other GCP-compliant means agreed between the Investigator and the Sponsor.

A site monitor designated by BioMarin will compare the eCRFs with the original source documents at the study site and evaluate them for completeness and accuracy before designating them as "Source Data Verified" (SDV). If an error is discovered at any time or a clarification is needed, the site monitor, or designee, will create an electronic query on the associated field. Site personnel will then answer the query by either correcting the data or responding to the query. The site monitor will then review the response and determine either to close the query or re-query the site if the response does not fully address the question. This process is repeated until all open queries have been answered and closed.

Before a subject's eCRF casebook can be locked, data fields must be source data verified and all queries closed. Refer to the Study Monitoring Plan for details on which fields must be

source data verified. The Investigator will then electronically sign the casebook, specifying that the information on the eCRFs is accurate and complete. The Data Manager, or designee, will then set the status of the forms, visits, and the entire casebook to Locked. Upon completion of the CSR, an electronic copy of each site's casebooks will be copied to a compact disk (CD) and sent to each site for retention with other study documents.

**18 STUDY MONITORING AND AUDITING**

Qualified individuals designated by BioMarin will monitor all aspects of the study according to GCP and standard operating procedures for compliance with applicable government regulations. The Investigator agrees to allow these monitors direct access to the clinical supplies, dispensing, and storage areas and to the clinical files, including original medical records, of the study subjects, and, if requested, agrees to assist the monitors.

The Investigator and staff are responsible for being present or available for consultation during routinely scheduled site visits conducted by BioMarin or its designees.

Members of BioMarin's GCP Compliance Department or designees may conduct an audit of a clinical site at any time before, during, or after completion of the study. The Investigator will be informed if an audit is to take place and advised as to the scope of the audit.

Representatives of the FDA or other Regulatory Agencies may also conduct an audit of the study. If informed of such an inspection, the Investigator should notify BioMarin immediately. The Investigator will ensure that the auditors have access to the clinical supplies, study site facilities, original source documentation, and all study files.

## **19 RETENTION OF RECORDS**

The Investigator must retain all study records required by BioMarin and by the applicable regulations in a secure and safe facility. The Investigator must consult a BioMarin representative before disposal of any study records, and must notify BioMarin of any change in the location, disposition or custody of the study files. The Investigator /institution must take measures to prevent accidental or premature destruction of essential documents, that is, documents that individually and collectively permit evaluation of the conduct of a study and the quality of the data produced, including paper copies of study records (eg, subject charts) as well as any original source documents that are electronic as required by applicable regulatory requirements.

All study records must be retained for at least 2 years after the last approval of a marketing application in the US or an ICH region and until (1) there are no pending or contemplated marketing applications in the U.S. or an ICH region or (2) at least 2 years have elapsed since the formal discontinuation of clinical development of the IP. The Investigator /institution should retain subject identifiers for at least 15 years after the completion or discontinuation of the study. Subject files and other source data must be kept for the maximum period of time permitted by the hospital, institution or private practice, but not less than 15 years. These documents should be retained for a longer period, however, if required by the applicable regulatory requirements or by a BioMarin agreement. BioMarin must be notified and will assist with retention should Investigator /institution be unable to continue maintenance of subject files for the full 15 years. It is the responsibility of BioMarin to inform the Investigator /institution as to when these documents no longer need to be retained.

**20 USE OF INFORMATION AND PUBLICATION**

BioMarin recognizes the importance of communicating medical study data and therefore encourages the publication of these data in reputable, peer-reviewed scientific journals and at seminars or conferences. The details of the processes of producing and reviewing reports, manuscripts, and presentations based on the data from this study will be described in the Clinical Trial Agreement between BioMarin and the Investigator/Institution. Consideration for authorship of all publications will be based on compliance with the Uniform Requirements for Manuscripts Submitted to Biomedical Journals (“Uniform Requirements”) of the International Committee of Medical Journal Editors (ICMJE) ([http://www.icmje.org/ethical\\_1author.html](http://www.icmje.org/ethical_1author.html)) and good publication practices (GPP).



---

## 21 REFERENCES

- Batts KP & Ludwig J. Chronic hepatitis: an update on terminology and reporting. *Am J Surg Pathol* 19:1409-1417. 1995.
- Bedossa P, Pynard T, French METAVIR Cooperative Study Group. An algorithm for grading activity in chronic hepatitis C. *Hepatology* 24;289-293. 1996.
- Berntorp E, Dolan G, Hay C, Linari S et al. European retrospective study of real-life haemophilia treatment. *Haemophilia*. 2017;23(1):105-114.
- Berntorp E, Peake I, Budde U, Laffan M et. al. von Willebrand's disease: a report from a meeting in the Aland islands. *Haemophilia* 18 Suppl 6, 1-13. 2012.
- Brooks R. EuroQol: the current state of play. *Health Policy*. 1996;37:53-72.
- Chai-Adisaksopha C, Skinner M, Curtis R, et al. Psychometric Properties of the Patient Reported Outcomes, Burdens and Experiences (PROBE) Questionnaire. *Blood*. 2017;130:5645.
- EuroQol Group. EuroQol – a new facility for the measurement of health-related quality of life. *Health Policy*. 1990;16:199-208.
- George LA, Sullivan S, Teitel J, Cuker A et al. Preliminary results of a phase 1/2 trial of SPK-9001, a hyperactive FIX variant delivered by a novel capsid, demonstrate consistent factor IX activity levels at the lowest dose cohort. *Haemophilia* 22[Suppl. 4], 151-152. 2016.
- Grant A, Neuberger J, Day C, Saxseena S. British Society of Gastroenterology Guidelines on the use of Liver Biopsy in Clinical Practice. 2004. Available at: <https://www.bsg.org.uk/resource/bsg-guidelines-on-the-use-of-liver-biopsy-in-clinical-practice.html> (last visited 20 January 2020).
- Hay CR, DiMichele DM. The principal results of the International Immune Tolerance Study: a randomized dose comparison  
12. *Blood* 119[6], 1335-1344. 2012.
- Haemo-QoL Study Group. Scoring Manual. Available at: <http://haemoqol.de/scoring/manual>. Last accessed 28 July 2017.
- Kaufman RJ, Powell JS. Molecular approaches for improved clotting factors for hemophilia 1. *Blood* 122[22], 3568-3574. 2013.

Manno CS, Pierce GF, Arruda VR, Glader B et. al. Successful transduction of liver in hemophilia by AAV-Factor IX and limitations imposed by the host immune response. *Nat Med* 12[3], 342-347. 2006.

Miesbach W, Tangelder M, Klamroth R, Schutgens R et al. Updated results from a dose escalating study in adult patients with haemophilia B with AMT-060 (AAV5-hFIX) gene therapy. *Haemophilia* 22[Suppl. 4], 151-152. 2016.

Mingozzi F and High KA. Immune responses to AAV vectors: overcoming barriers to successful gene therapy. *Blood* 122[1], 23-36. 2013.

National Center for Biotechnology Information (NCBI). LiverTox: Clinical and Research Information on Drug-Induced Liver Injury. Available at: <https://livertox.nih.gov> (last accessed 14 January 2020).

Nathwani AC, Reiss UM, Tuddenham EG, Rosales C et. al. Long-term safety and efficacy of factor IX gene therapy in hemophilia B. *N Engl J Med* 371[21], 1994-2004. 2014.

Nathwani AC, Rosales, C, McIntosh J, Rastegarlarlari G et. al. Long-term safety and efficacy following systemic administration of a self-complementary AAV vector encoding human FIX pseudotyped with serotype 5 and 8 capsid proteins. *Mol Ther* 19[5], 876-885. 2011.

Nathwani AC, Tuddenham EG. Epidemiology of coagulation disorders. *Baillieres Clin Haematol* 5[2], 383-439. 1992.

Pasi KJ, Rangarajan S, Kim B et al. Achievement of Normal Circulating Factor VIII Activity Following BMN 270 AAV5-FVIII Gene Transfer: Interim, Long-Term Efficacy and Safety Results from a Phase 1/2 Study in Patients with Severe Hemophilia A. *Blood* 130[Suppl. 1], 603. 2017.

Rangarajan S, Kim B, Lester W et al. Achievement of normal factor VIII activity following gene transfer with valoctocogene roxaparvovec (BMN 270): Long-term efficacy and safety results in patients with severe hemophilia A. *Haemophilia* 24[Suppl. 5], 65. 2018

Reilly M. WPAI Scoring. 2002. Available at: [http://www.reillyassociates.net/WPAI\\_Scoring.html](http://www.reillyassociates.net/WPAI_Scoring.html). Last accessed 28 July 2017.

Recht M, Neufeld EJ, Sharma VR, Solem CT et al. Impact of Acute Bleeding on Daily Activities of Patients with Congenital Hemophilia with Inhibitors and Their Caregivers and Families: Observations from the Dosing Observational Study in Hemophilia (DOSE). *Value in Health*. 2014;17:744-748.

Rentz A, Flood E, Altisent C, Bullinger M et al. Cross-cultural development and psychometric evaluation of a patient-reported health-related quality of life questionnaire for adults with haemophilia. *Haemophilia* 2008;14(5):1023-34.

Sampson HA, Muñoz-Furlong A, Campbell RL, et al. Second symposium on the definition and management of anaphylaxis: summary report—second National Institute of Allergy and Infectious Disease/Food Allergy and Anaphylaxis Network symposium. *J Allergy Clin Immunol* 2006;117:391-397.

Srivastava A, Brewer AK, Mauser-Bunschoten EP, Key NS et. al. Guidelines for the management of hemophilia 128. *Haemophilia* 19[1], e1-47. 2013.

Stonebraker JS, Brooker M, Amand RE, Farrugia A et. al. A study of reported factor VIII use around the world. *Haemophilia* 16[1], 33-46. 2010.

United States Department of Health and Human Services. Guidelines for the Use of Antiretroviral Agents in HIV-1-Infected Adults and Adolescents. 2014. Available at <https://aidsinfo.nih.gov/guidelines/html/1/adult-and-adolescent-arv-guidelines/458/plasma-hiv-1-rna--viral-load--and-cd4-count-monitoring>. Last accessed 28 July 2017.

Van Genderen FR, Westers P, Heijnen L, De Kleijn P et al. Measuring patients' perceptions on their functional abilities: validation of the Haemophilia Activities List. *Haemophilia*. 2006;12:36-46.

Wiens BL, Dmitrienko A. The fallback procedure for evaluating a single family of hypotheses. *J Biopharm Stat*. 2005; 15:929–942.

---

## **22 INVESTIGATOR RESPONSIBILITIES**

### **22.1 Conduct of Study and Protection of Human Patients**

In accordance with FDA Form 1572 and/or principles of ICH E6 GCP, the Investigator will ensure that:

- He or she will conduct the study in accordance with the relevant, current protocol and will only make changes in a protocol after notifying the sponsor, except when necessary to protect the safety, rights, or welfare of subjects.
- He or she will personally conduct or supervise the study.
- He or she will inform any potential subjects, or any persons used as controls, that the drugs are being used for investigational purposes, and he or she will ensure that the requirements relating to obtaining informed consent in 21 CFR Part 50 and/or ICH E6 sections 2.9 and 4.8 are met. As well, he or she will ensure that IRB/IEC review and approval in 21 CFR Part 56 and/or ICH E6 section 2.6 are met.
- He or she will report to the sponsor adverse experiences that occur in the course of the investigation in accordance with 21 CFR 312.64 and/or ICH E6 Section 4.11.
- He or she has read and understands the information in the Investigator's Brochure, including potential risks and side effects of the drug.
- His or her staff and all persons who assist in the conduct of the study are informed about their obligations in meeting the above commitments
- Adequate and accurate records in accordance with 21 CFR 312.62 and/or ICH E6 section 4.9 are kept, and those records are available for inspection in accordance with 21 CFR 312.68 and/or ICH E6 section 4.9.7.
- The IRB/EC/REB complies with the requirements of 21 CFR Part 56, ICH E6 Section 3.0, and other applicable regulations, and conducts initial and ongoing reviews and approvals of the study. He or she will also ensure that any change in research activity and all problems involving risks to human subjects or others are reported to the IRB/EC/REB. Additionally, he or she will not make any changes in the research without IRB/EC/REB approval, except where necessary to eliminate apparent immediate hazards to human subjects.
- He or she agrees to comply with all other requirements regarding the obligations of clinical Investigators and all other pertinent requirements in 21 CFR Part 312 and/or ICH E6.

**23 SIGNATURE PAGE**

**Protocol Title:** A Phase 3 Open-Label, Single Arm Study To Evaluate The Efficacy and Safety of BMN 270, an Adeno-Associated Virus Vector-Mediated Gene Transfer of Human Factor VIII in Hemophilia A Patients with Residual FVIII Levels  $\leq$  1 IU/dL Receiving Prophylactic FVIII Infusions

**Protocol Number:** 270-301 Amendment 6

I have read the forgoing protocol and agree to conduct this study as outlined. I agree to conduct the study in compliance with all applicable regulations and guidelines, including ICH E6, as stated in the protocol, and other information supplied to me.

Investigator Signature

Date

Printed name: \_\_\_\_\_

**Accepted for the Sponsor:**

**PI**

Medical Monitor Signature

Date

Printed name: **PI** \_\_\_\_\_, Clinical Sciences

## 24 APPENDIX 1: SAMPSON'S ANAPHYLAXIS CRITERIA

According to the National Institute of Allergy and Infectious Disease/Food Allergy and Anaphylaxis Network (NIAID/FAAN) Second Symposium on the definition and management of anaphylaxis, anaphylaxis is highly likely when any one of the following 3 criteria are fulfilled:

1. Acute onset of an illness (minutes to several hours) with involvement of the skin, mucosal tissue, or both (eg, generalized hives, pruritus or flushing, swollen lips-tongue-uvula)
 

*AND AT LEAST ONE OF THE FOLLOWING*

  - a. Respiratory compromise (eg, dyspnea, wheeze-bronchospasm, stridor, reduced peak expiratory flow [PEF], hypoxemia)
  - b. Reduced blood pressure (BP) or associated symptoms of end-organ dysfunction (eg, hypotonia [collapse], syncope, incontinence)
2. Two or more of the following that occur rapidly after exposure to a likely allergen for that patient (minutes to several hours):
  - a. Involvement of the skin-mucosal tissue (eg, generalized hives, itch-flush, swollen lips-tongue-uvula)
  - b. Respiratory compromise (eg, dyspnea, wheeze-bronchospasm, stridor, reduced PEF, hypoxemia)
  - c. Reduced BP or associated symptoms (eg, hypotonia [collapse], syncope, incontinence)
  - d. Persistent gastrointestinal symptoms (eg, crampy abdominal pain, vomiting)
3. Reduced BP after exposure to known allergen for that patient (minutes to several hours):
  - a. Infants and children: low systolic blood pressure (age specific) or greater than 30% decrease in systolic BP
  - b. Adults: systolic BP of less than 90 mmHg or greater than 30% decrease from that person's baseline.

Source: [Sampson, 2006](#).

## 25 PROTOCOL AMENDMENT TEXT REVISIONS

The following table summarizes the revisions made to the protocol and relates the changes to the appropriate rationale (see pages 2-6).

Added text is indicated by underlined font and deleted text is indicated by ~~strikethrough~~ font.

| Section No./Title                  | Revision   | Rationale    |
|------------------------------------|--|--------------|
| 2/Synopsis (Study Rationale)       | Figure 1 and its accompanying notes have been updated  | 17           |
| 2/Synopsis (Objectives)            | <p><u>The exploratory objectives of the liver biopsy substudy are:</u></p> <ul style="list-style-type: none"> <li><u>To examine the histopathology of the liver following BMN 270 therapy, including assessing for possible safety findings (eg, fibrosis, fatty liver disease, lymphocytic invasion)</u></li> <li><u>To quantify FVIII DNA, RNA, and protein expression within hepatocytes</u></li> <li><u>To determine which forms of rAAV vector DNA are present at the time of biopsy.</u></li> <li><u>To determine the transduction pattern of BMN 270 in humans (ie, peri-portal hepatocytes, central vein hepatocytes)</u></li> </ul>   | 10           |
| 2/Synopsis (Study Design and Plan) | <p><del>An</del> <u>Two interim analysis is</u> analyses were planned, after the first approximately 16 and 20 treated HIV-negative subjects <del>have,</del> respectively, completed the Week 26 visit. <del>Data will be reviewed by the DMC, (or have discontinued study participation prior to</del> <u>Week 26). The first interim analysis was performed as planned in May 2019. Based on the statistical interim results and the totality of the data, the secondary interim analysis plan, and a formal recommendation will be made</u> as deemed unnecessary. The DMC reviewed interim analysis results to assess the efficacy and safety profiles, whether <del>to continue the study as designed, the pre-</del> <u>specified criteria of statistical significance has been achieved, and the risk/benefit ratio of the interventions in the BMN 270 studies based on the totality of the data.</u></p> <p>...</p> <p>Subjects who do not respond to BMN 270 treatment (ie, treatment failure, manifesting as either failure to achieve FVIII activity <math>\geq</math> 5 IU/dL by Week 52 or inability to maintain independence from prophylactic FVIII replacement therapy due to joint bleeding episodes, in the judgment of the Investigator) may, at the Investigator's discretion and after discussion with the Medical Monitor or Sponsor-designated Data Monitor, follow an abbreviated visit schedule after Week 52 of the study by attending only the Q12W and End of Year visits during Years 2-5. <u>Subjects who are not attending the Q4W/Q6W visits during Years 2-5 may receive a scheduled monthly follow-up telephone call from the site to ask about adverse events, concomitant medications, and bleeding events/FVIII replacement usage.</u></p> <p>There will be an ongoing review of individual subject safety by the Medical Monitor, and both safety and efficacy data by the DMC. Therapeutic oral corticosteroids <u>or other systemic immunosuppressive agents</u> may be initiated when a subject's ALT values are elevated, and subsequent dosage adjustments made, after consultation between the Investigator and the Medical Monitor.</p> | 1, 3, 10, 12 |





| Section No./Title                           | Revision   | Rationale    |
|---|--|--------------|
|   | <p><u>An optional liver biopsy will be performed (in subjects who consent to do so) during Year 1 post-infusion, at or around Week 52, and/or during Years 2-5 following BMN 270 infusion. Subjects who consent to the liver biopsy will have additional assessments, including a liver ultrasound and FibroScan, and will receive prophylactic FVIII prior to the procedure, as indicated in the judgment of the Investigator, to minimize the risk of bleeding.</u></p>  |              |
| <p>2/Synopsis (Inclusion and Exclusion)</p> | <p>Patients are eligible to be included in the study only if all of the following criteria apply:</p> <p>6. Sexually active participants must agree to use an acceptable method of effective contraception, either double-barrier contraception (ie, condom + diaphragm; or condom or diaphragm + spermicidal gel or foam) or their female partner either using hormonal contraceptives or having an intrauterine device. Participants must agree to contraception use for at least 12 weeks post-infusion; after 12 weeks, subjects may stop contraception use only if they have had 3 consecutive semen samples with <del>no detectable</del> viral vector DNA <u>below the limit of detection.</u></p> <p><u>Optional Liver Biopsy Inclusion and Exclusion Criteria</u></p> <p><u>Individuals eligible for the optional liver biopsy must meet the following inclusion criterion:</u></p> <ol style="list-style-type: none"> <li><u>Able to sign informed consent and comply with requirements for the optional liver biopsy</u></li> <li><u>Documentation of FVIII activity level <math>\geq</math> 50 IU/dL (or higher, depending on local guidelines and/or Investigator discretion) within 24 hours prior to the liver biopsy being performed (FVIII activity levels should be assessed at the local laboratory). Subjects may be treated with additional exogenous FVIII replacement products in order to increase their FVIII activity to an appropriate level, under the supervision/instruction of the Investigator.</u></li> </ol> <p><u>Individuals who meet any of the following exclusion criteria will not be eligible for the optional liver biopsy:</u></p> <ol style="list-style-type: none"> <li><u>Any condition that, in the opinion of the Investigator or a hepatologist or radiologist, would make liver biopsy contraindicated. This includes (but is not limited to): abnormalities detected on liver ultrasound performed within 28 days of procedure or prior liver ultrasound result within 90 days that would preclude safe performance of the biopsy.</u></li> </ol> | <p>4, 10</p> |
| <p>2/Synopsis (Criteria for Evaluation)</p> | <p>The following safety outcome measurements will be assessed:</p> <ul style="list-style-type: none"> <li>• Vector shedding (blood, urine, semen, <del>feces</del>stool, saliva)</li> <li>• Liver tests (LTs, including ALT, AST, GGT, <u>direct and total bilirubin, lactate dehydrogenase [LDH], and alkaline phosphatase</u>)</li> </ul>  | <p>22</p>    |
| <p>2/Synopsis (Statistical Methods)</p>     | <p><u>An <del>Two</del> interim analysis <del>is</del> analyses were planned, after approximately 16 and 20 treated HIV-negative subjects have, respectively, completed the Week 26 visit (or have discontinued study participation prior to Week 26). Data will be reviewed by the DMC. The first interim analysis was performed as planned in May 2019. Based on the SAP, and a formal recommendation will be made interim results and the totality of the data, the secondary interim analysis was deemed unnecessary. The DMC reviewed the interim analysis</u></p>  | <p>1</p>     |





| Section No./Title                                    | Revision  | Rationale |
|--|---|-----------|
|  | <p><del>results to assess the efficacy and safety profiles, whether to continue the study as designed the pre-specified criteria of statistical significance has been achieved, and the risk/benefit ratio of the interventions in the BMN 270 studies based on the totality of the data.</del></p> <p><del>Adjustment</del> <u>The fallback procedure will be used to adjust for multiplicity for the interim analysis at Week 26 and the final analysis at Week 52 will be described in the SAP (regardless of the interim analysis results, the study is planned to continue upon the DMC’s recommendation, and the final analysis will be performed at Week 52). At the final analysis at Week 52, the secondary efficacy endpoints will be tested hierarchically; the level of significance will be determined by the fallback procedure.</u></p> <p>The secondary <del>and tertiary</del> <u>efficacy endpoints at the interim analysisanalyses (Week 26) will be summarized descriptively.</u></p> <p><del>The tertiary endpoints will be analyzed at the interim (Week 26) and final (Week 52) analyses, irrespective of the aforementioned hierarchical testing.</del></p> <p>Details of the interim <del>analysisanalyses</del>, including the control of Type I error rate, will be specified in the SAP.</p>  |           |
| Figure 7.3.1/Vector Genome                           | Figure 7.3.1 and its corresponding notes have been updated.   | 17        |
| <u>Section 7.3.1/Optional Liver Biopsy Rationale</u> | <p><u>The usual pattern of response in hFVIII activity observed so far after administration of BMN 270 demonstrates peak expression levels during the first 6-12 months post-treatment followed by a decline to a steady-state level of expression thereafter. One of the explanations may lie in the kinetics of vector genome processing, which involves a series of steps such as DNA degradation and repair, annealing, and circularization that can result in the formation of stable, double-stranded, circularized transgene DNA forms. It is these circularized DNA species that are thought to be associated with long-term, persistent expression of the gene product in target cells. Examination of transduced hepatocytes from subjects treated with BMN 270 in the 270-301 study will help to establish whether DNA circularization may occur and could account for the long-term hFVIII expression observed in humans.</u></p> <p><u>Additionally, health of the liver after gene transduction has been monitored indirectly by periodic assessments of hepatic enzymes released into the blood stream. Transient, post-treatment elevations in ALT levels have been observed in the majority of subjects, as well as inter-subject variability in post-therapy FVIII activity levels. Neither the reasons for nor the significance of the ALT elevations or the variations in response to FVIII gene therapy are known. Moreover, the effects of BMN 270 on hepatic tissue structure and function are also currently unknown. Finally, a call to incorporate liver biopsy sub-studies into gene therapy trials for hemophilia has been issued by medical and scientific leaders in the field to help illuminate these and other questions (National Hemophilia Foundation, 2019).</u></p> <p><u>The purpose of this exploratory sub-study is to provide a better understanding of the long-term gene expression related to genome circularization, health of the liver, and variation in FVIII activity levels observed after gene therapy with BMN 270. With use of prophylactic corticosteroids, it is believed that there will be stable hepatic function and FVIII activity expression, with tolerance of</u></p> | 10        |



| Section No./Title  | Revision   | Rationale |
|--|--|-----------|
|  | <p><u>prophylactic corticosteroid therapy and no change to the risk of thromboembolism. This sub-study aims to evaluate the effect on the liver by performing liver biopsies during Year 1 post-infusion, at or around Week 52, and/or during Years 2-5.</u></p>   |           |
| <p>Section 7.4/Summary of Overall Risks and Benefits</p> | <p>The majority of subjects in the ongoing 270-201 clinical study who have received 4E13 or 6E13 vg/kg doses of BMN 270 have had Grade 1 asymptomatic elevations in ALT. For most subjects, the elevations have reached only slightly above the ULN. Based on the effectiveness of transient oral corticosteroid used to suppress a presumed cytotoxic T cell response in prior studies with hepatic transduction with AAV vectors (Mingozzi, 2013), subjects were treated with 7-32 weeks of oral corticosteroids preventatively or in response to the elevations in ALT to ensure preservation of the transduced hepatocytes. Using this approach, no sustained loss of FVIII activity has been observed in subjects with ALT elevations, consistent with maintaining a high level of hepatocyte function. Moreover, the rise in ALT levels were not accompanied by significant or lasting aberrations in other liver tests such as AST, bilirubin or albumin, indicating that extent of toxicity is limited. There has been one HIV positive subject in the ongoing 270-302 clinical study who experienced Grade 3 asymptomatic elevations in ALT and AST, which has been attributed to an interaction between one or more of his antiretroviral therapy medications and/or unsuspected underlying hepatic disease with BMN 270. In addition, there has been one subject with Gilbert's syndrome in the ongoing 270-301 clinical study who has experienced Grade 3 asymptomatic elevations in ALT and AST. These cases have led to the exclusion of subsequent HIV positive subjects and requirement of liver tests at Screening that are &lt;1.25 times the upper limit of the normal range in the ongoing 270-301 and 270-302 clinical studies. Of note, two HIV positive subjects in 270-301 and one presumed Gilbert's syndrome subject in 270-201 have received BMN 270 without experiencing any elevations in ALT to date. Overall, the literature and clinical experience with BMN 270 thus far suggest that transient elevations in liver enzymes are expected following AAV-based gene therapy for the treatment for hemophilia A or B without any long term concerns of hepatic injury); (); (George, 2016); (Miesbach, 2016); (Pasi, 2017).</p> <p><u>BMN 270 has an acceptable safety and tolerability profile that supports a positive benefit-risk assessment. Single infusions have been generally well tolerated by treated subjects across all investigated doses. All subjects have successfully completed their full-dose infusion of BMN 270, with no infusions requiring permanent termination prior to completion due to AEs. No deaths have been reported in any of the BMN 270 studies, and no participants discontinued from studies as a result of an AE. Frequency of adverse events decreased over time with no delayed adverse drug reactions.</u></p> <p><u>Infusion reactions associated with BMN 270 administration included symptoms such as maculopapular rash, urticaria, nausea, diarrhea, watery eyes, rigors, chills, myalgia, fever, tachycardia and hypotension emerging within 24 hours of receiving BMN 270. All of these events subsided without clinical sequela within 48 hours following medical management. Infusion-related reactions were effectively mitigated by managing infusion rate and medications.</u></p> | <p>18</p> |



| Section No./Title  | Revision  | Rationale |
|--|---|-----------|
|  | <p><u>Transient, asymptomatic ALT elevation (grade 1 to 3 in severity) was observed in most subjects administered BMN 270 shortly after dosing, with no symptoms or sequelae suggestive of clinically significant hepatocyte injury or liver dysfunction. In almost all subjects, ALT elevations decreased quickly following corticosteroid treatment. There were differences in the use of corticosteroids across studies. Subjects in 270-201 received corticosteroids an average of 8 weeks earlier following BMN 270 infusion than the mITT population in 270-301, were more likely to avoid a significant decline in FVIII activity concurrently with an ALT elevation, and saw a more robust recovery of FVIII activity upon the first use of corticosteroids, than did the subjects in the mITT population in 270-301. Despite the clinical response to steroids, no associations between safety parameters (transient ALT rises), or efficacy as measured by FVIII activity levels were found to be temporally associated with anti-AAV5 antibody or cellular immune responses.</u></p> <p><u>As with any infused biological product, there is a potential risk of acute, systemic hypersensitivity reactions (including anaphylaxis) with BMN 270. No hypersensitivity reactions were observed during dosing of BMN 270 in the 270-201 clinical study, although one SAE of pyrexia was reported approximately 16 hours after the infusion in a subject in the 4E13 vg/kg cohort. The subject was treated with acetaminophen, and the fever resolved within 48 hours (see Investigator’s Brochure for full details). Infusion-related reactions, including allergic reaction, maculopapular rash, and presyncope, have been reported from ongoing, actively dosing clinical studies of BMN 270, including this study. All of the infusion-related reactions were effectively managed clinically and resolved without any clinical sequelae. Refer to the Investigator’s Brochure for additional details.</u></p> <p><u>In 270-301, an interim analysis has shown increased FVIII activity in the majority of subjects to mild HA or normal levels at 26 weeks post-infusion, also with markedly decreased bleeding compared with pre-study rates and the ability to discontinue prophylactic FVIII infusions. All subjects who will be included in the final analysis have been dosed with 6E13 vg/kg and continue to be followed.</u></p> <p><u>The current data available for BMN 270 does not yet permit adequate assessment of the has shown an established positive benefit:risk profile of this investigational drug for BMN 270 at the 6E13 vg/kg dosing level. Given the monitoring measures in place in the clinical protocol(s) to minimize the risk to subjects participating in the existing studies, the identified risks are justified by the anticipated benefits that may be afforded to subjects. Each subject in 270-301 will have a comprehensive surveillance plan that monitors LTs during the study, and elevations in LTs will be addressed according to the guidelines set forth in the protocol. Safety will be assessed by adverse event reporting and clinical laboratory assessments.</u></p> <p><u>For additional information on <del>findings in 270-201</del> the risks and benefits of treatment with BMN 270, refer to the current version of the Investigator’s Brochure.</u></p> |           |
| <p><u>Section 7.4.1/Optional Liver Biopsy Risks and Benefits</u></p> | <p><u>Liver biopsy is considered a safe procedure, with serious complications occurring less than once in every 10,000 procedures (Grant, 2004). Although the theoretical risks of significant complications are extremely small, the main complications would include</u></p>  | <p>10</p> |



| Section No./Title                         | Revision  | Rationale    |
|---|---|--------------|
|   | <p><u>bleeding and bile leakage. Another theoretical complication is infection at the needle insertion site; the sterile technique used makes this risk extremely small.</u></p> <p><u>The most common problems include mild pain and a minor decrease in blood pressure. More serious complications, such as bleeding, infection, and injury to nearby organs, are very rare, but the subject will be monitored appropriately to ensure correct management should any of these occur. Any complications related to the liver biopsy should be reported as adverse events, as outlined in Section 10. The liver biopsy is a standard investigation, and will be explained more fully by the experienced clinician performing the biopsy.</u></p> <p><u>Each subject who participates in this optional sub-study will have a comprehensive pre-/post-biopsy surveillance plan according to the standard procedures at the institution. Timing of the liver biopsies will occur at Weeks 26, 52, and/or during Years 2-5. Safety will be assessed by adverse event reporting and clinical laboratory assessments. Per the Investigator's discretion and/or according to local guidelines, the subject may be kept in overnight following the liver biopsy for additional safety monitoring; such an overnight stay would not be considered a hospitalization for serious adverse event (SAE) reporting purposes (refer to Section 10.4.1.7).</u></p> <p><u>There is no direct benefit from participating in this study other than contributing to understanding the mechanism of action of BMN 270. Consenting into this specific sub-study is optional and will not have any effect on the subject's continued participation in 270-301.</u></p> |              |
| Section 8/Study Objectives                | <p><u>The exploratory objectives of the liver biopsy substudy are:</u></p> <ul style="list-style-type: none"> <li>• <u>To examine the histopathology of the liver following BMN 270 therapy, including assessing for possible safety findings (eg, fibrosis, fatty liver disease, lymphocytic invasion)</u></li> <li>• <u>To quantify FVIII DNA, RNA, and protein expression within hepatocytes</u></li> <li>• <u>To determine which forms of rAAV vector DNA are present at the time of biopsy.</u></li> <li>• <u>To determine the transduction pattern of BMN 270 in humans (ie, peri-portal hepatocytes, central vein hepatocytes)</u></li> </ul>  | 10           |
| Section 9.1/Overall Study Design and Plan | <p><del>An interim analysis is planned after 20 treated HIV-negative subjects have completed the Week 26 visit. Two interim analyses were planned, after the first approximately 16 and 20 treated HIV-negative subjects, respectively, completed the Week 26 visit (or have discontinued study participation prior to Week 26). The first interim analysis was performed as planned in May 2019. Based on the interim results and the totality of the data, the secondary interim analysis was deemed unnecessary. The DMC reviewed interim analysis results to assess the efficacy and safety profiles, whether the pre-specified criteria of statistical significance has been achieved, and the risk/benefit ratio of the interventions in the BMN 270 studies based on the totality of the data.</del></p> <p>...</p>  | 1, 3, 10, 12 |



| Section No./Title                             | Revision  | Rationale                 |
|---|---|---------------------------|
|   | <p>There will be an ongoing review of individual subject safety by the Medical Monitor, and both safety and efficacy data by the DMC. Therapeutic oral corticosteroids <u>or other systemic immunosuppressive agents</u> may be initiated when a subject's ALT values are elevated, and subsequent dosage adjustments made, after consultation between the Investigator and the Medical Monitor.</p> <p>Subjects who do not respond to BMN 270 treatment (ie, treatment failure, manifesting as either failure to achieve FVIII activity <math>\geq 5</math> IU/dL by Week 52 or inability to maintain independence from prophylactic FVIII replacement therapy due to joint bleeding episodes, in the judgment of the Investigator) may, at the Investigator's discretion and after discussion with the Medical Monitor or Sponsor-designated Data Monitor, follow an abbreviated visit schedule after Week 52 of the study by attending only the Q12W and End of Year visits during Years 2-5. <u>Subjects who are not attending the Q4W/Q6W visits during Years 2-5 may receive a scheduled monthly follow-up telephone call from the site to ask about adverse events, concomitant medications, and bleeding events/FVIII replacement usage.</u></p> <p>...</p> <p><u>An optional liver biopsy will be performed (in subjects who consent to do so) during Year 1 post-infusion, at or around Week 52, and/or during Years 2-5 following BMN 270 infusion. Subjects who consent to the liver biopsy will have additional assessments, including a liver ultrasound and FibroScan, and will receive prophylactic FVIII prior to the procedure, as indicated in the judgment of the Investigator, to minimize the risk of bleeding.</u></p> |                           |
| Table 9.1.1-9.1.5/<br>Schedules of Events     | The Schedules of Events have been updated consistent with changes made elsewhere in the protocol.   | 2, 4, 7, 8, 9, 10, 19, 22 |
| Table 9.1.1/Screening<br>and Infusion (notes) | <p><sup>c</sup> Refer to Table 9.7.8.2.1 for laboratory assessments to be included, and to Table 9.7.8.3.1 for liver tests. ABO blood typing assessment should be performed <del>as part of the hematology assessment</del> (at Baseline, or at another regularly scheduled visit prior to the end of the subject's participation in the study).</p>  | 22                        |
| Table 9.1.2/Week 1-16<br>(notes)              | <p><sup>b</sup> Refer to Table 9.7.8.2.1 for laboratory assessments to be included, and to Table 9.7.8.3.1 for liver tests (LTs). LTs may be monitored more or less frequently (and in particular when ALT values are <math>\geq 1.5x</math> ULN or <del><math>&gt; ULN</math> &amp; <math>&gt; 2x</math></del> <math>\geq 1.5x</math> baseline value) based on discussion between the Medical Monitor and the Investigator and review of subject data, but LTs will be monitored at least twice weekly during periods when a subject's ALT is <math>\geq 3x</math> ULN. Subjects with ALT <del><math>&gt; 1.5x</math> ULN or <math>&gt; ULN</math> &amp; <math>&gt; 2x</math></del> <math>\geq 1.5x</math> baseline value during the study and either an alternative etiology considered or for further evaluation of the lab abnormality may undergo additional evaluations (eg, imaging studies including MRI or ultrasound, additional blood tests, and/or liver biopsy) at the discretion of the Investigator.</p> <p><sup>d</sup> Collection for each matrix to occur until at least 3 consecutive <del>negative</del> <u>negative results below the limit of detection</u> are obtained. Collection and testing of semen samples must continue at least through Week 12, even if 3 consecutive <del>negative</del> <u>negative results below the limit of detection</u> in that compartment have already been recorded.</p>  | 4, 8, 9                   |



| Section No./Title                     | Revision  | Rationale          |
|---------------------------------------|---|--------------------|
|                                       | <p><sup>g</sup> For subjects who have entered 270-301 following participation in 270-902, the scheduled visits at Week 5, Week 7, Week 9, Week 11, Week 13, and Week 15 may be performed by a mobile nursing (MN) professional at the subject’s home or another suitable location (if the subject has given written informed consent to participate in MN visits), or at the site as a shortened lab draw-only visit. The MN service or site will collect blood samples at these visits. For site lab draw-only visits, sites will contact the subject via phone call or e-mail to collect information regarding adverse events, changes to concomitant medications, bleeding episodes, and FVIII use. For MN visits, the service will collect this information. The physical examination and vital signs assessments listed in the Schedule of Events will not be performed at these MN or lab draw-only visits for subjects who have entered 270-301 following participation in 270-902. <u>In the event that neither a lab-only visit or MN visit can be conducted within the visit window, the site should telephone the subject to collect adverse event, concomitant medication, and diary data (bleeding events and FVIII usage).</u></p>  |                    |
| <p>Table 9.1.3/Week 17-32 (Notes)</p> | <p><sup>b</sup> Refer to Table 9.7.8.2.1 for laboratory assessments to be included, and to Table 9.7.8.3.1 for liver tests (LTs). LTs may be monitored more or less frequently (and in particular when ALT values are <math>\geq 1.5x</math> ULN or <math>&gt; ULN \&amp; &gt; 2x \geq 1.5x</math> baseline value) based on discussion between the Medical Monitor and the Investigator and review of subject data, but LTs will be monitored at least twice weekly during periods when a subject’s ALT is <math>\geq 3x</math> ULN. Subjects with ALT <math>\geq 1.5x</math> ULN or <math>&gt; ULN \&amp; &gt; 2x \geq 1.5x</math> baseline value during the study and either an alternative etiology considered or for further evaluation of the lab abnormality may undergo additional evaluations (eg, imaging studies including MRI or ultrasound, additional blood tests, and/or liver biopsy) at the discretion of the Investigator.</p> <p><sup>d</sup> Collection for each matrix to occur until at least 3 consecutive <del>negative</del> results below the limit of detection are obtained.</p> <p><sup>f</sup> For subjects who have entered 270-301 following participation in 270-902, the scheduled visits at Week 17, Week 19, Week 21, Week 23, Week 25, Week 27, Week 29, Week 30, and Week 31 may be performed by a mobile nursing (MN) professional at the subject’s home or another suitable location (if the subject has given written informed consent to participate in MN visits), or at the site as a shortened lab draw-only visit. The MN service or site will collect blood samples at these visits. For site lab draw-only visits, sites will contact the subject via phone call or e-mail to collect information regarding adverse events, changes to concomitant medications, bleeding episodes, and FVIII use. For MN visits, the service will collect this information. The physical examination and vital signs assessments listed in the Schedule of Events will not be performed at these MN or lab draw-only visits for subjects who have entered 270-301 following participation in 270-902. <u>In the event that neither a lab-only visit or MN visit can be conducted within the visit window, the site should telephone the subject to collect adverse event, concomitant medication, and diary data (bleeding events and FVIII usage).</u></p> <p><sup>g</sup> <u>Subjects who elect to proceed will have a liver biopsy performed during Year 1 post-infusion. Additional liver biopsies at times deemed to be clinically relevant (eg, decreasing FVIII at a time of increased ALT) may be pursued. Subjects will be asked to</u></p> | <p>4, 8, 9, 10</p> |



| Section No./Title                     | Revision   | Rationale              |
|---------------------------------------|--|------------------------|
|                                       | <p><u>consent to the procedure for each liver biopsy performed during the study. Subjects should fast for at least 8 hours prior to liver ultrasound and optional liver biopsies.</u></p>  |                        |
| <p>Table 9.1.4/Week 33-52 (Notes)</p> | <p><sup>b</sup> Refer to Table 9.7.8.2.1 for laboratory assessments to be included, and to Table 9.7.8.3.1 for liver tests. LTs may be monitored more or less frequently (and in particular when ALT values are <math>\geq 1.5x</math> ULN or <math>&gt;ULN \&amp; &gt; 2x \geq 1.5x</math> baseline value) based on discussion between the Medical Monitor and the Investigator and review of subject data, but LTs will be monitored at least twice weekly during periods when a subject's ALT is <math>\geq 3x</math> ULN. Subjects with ALT <math>\geq 1.5x</math> ULN or <math>&gt;ULN \&amp; &gt; 2x \geq 1.5x</math> baseline value during the study and either an alternative etiology considered or for further evaluation of the lab abnormality may undergo additional evaluations (eg, imaging studies including MRI or ultrasound, additional blood tests, and/or liver biopsy) at the discretion of the Investigator.</p> <p><sup>c</sup> <u>Collection for each matrix to occur until at least 3 consecutive results below the limit of detection are obtained.</u></p> <p><sup>f</sup> For subjects who have entered 270-301 following participation in 270-902, the scheduled visits at Week 33, Week 34, Week 35, Week 38, Week 42, Week 46, and Week 50 may be performed by a mobile nursing (MN) professional at the subject's home or another suitable location (if the subject has given written informed consent to participate in MN visits), or at the site as a shortened lab draw-only visit. The MN service or site will collect blood samples at these visits. For site lab draw-only visits, sites will contact the subject via phone call or e-mail to collect information regarding adverse events, changes to concomitant medications, bleeding episodes, and FVIII use. For MN visits, the service will collect this information. The physical examination and vital signs assessments listed in the Schedule of Events will not be performed at these MN or lab draw-only visits for subjects who have entered 270-301 following participation in 270-902. <u>In the event that neither a lab-only visit or MN visit can be conducted within the visit window, the site should telephone the subject to collect adverse event, concomitant medication, and diary data (bleeding events and FVIII usage).</u></p> <p><sup>g</sup> <u>Subjects who elect to proceed will have a liver biopsy performed during Year 1 post-infusion, at or around Week 52. Additional liver biopsies at times deemed to be clinically relevant (eg, decreasing FVIII at a time of increased ALT) may be pursued. Subjects will be asked to consent to the procedure for each liver biopsy performed during the study. Subjects should fast for at least 8 hours prior to liver ultrasound and optional liver biopsies.</u></p> | <p>8, 9, 10, 22</p>    |
| <p>Table 9.1.5/Year 2-5 (Notes)</p>   | <p><sup>b</sup> Refer to Table 9.7.8.2.1 for laboratory assessments to be included, and to Table 9.7.8.3.1 for liver tests. LTs may be monitored more or less frequently (and in particular when ALT values are <math>\geq 1.5x</math> ULN or <math>&gt;ULN \&amp; &gt; 2x \geq 1.5x</math> baseline value) based on discussion between the Medical Monitor and the Investigator and review of subject data, but LTs will be monitored at least twice weekly during periods when a subject's ALT is <math>\geq 3x</math> ULN. Subjects with ALT <math>\geq 1.5x</math> ULN or <math>&gt;ULN \&amp; &gt; 2x \geq 1.5x</math> baseline value during the study and either an alternative etiology considered or for further evaluation of the lab abnormality may undergo additional evaluations (eg, imaging studies including MRI or ultrasound, additional blood tests, and/or liver biopsy) at the discretion of the Investigator.</p>  | <p>4, 8, 9, 10, 19</p> |





| Section No./Title   | Revision  | Rationale |
|---|---|-----------|
|   | <p><sup>d</sup> Sample testing during Long-Term Follow-Up is not required if at least 3 consecutive samples were <del>negative</del> <u>below the limit of detection</u> during the Post-Infusion Follow-Up period. Subjects who have not had 3 consecutive <del>negative</del> <u>semen samples below the limit of detection</u> by Week 52 should continue to have PCR testing of semen every 4 weeks (during Year 2) or every 6 weeks (during Years 3-5) until 3 consecutive <del>negative</del> <u>samples below the limit of detection</u> are documented (or upon consultation between the Investigator and Medical Monitor).</p> <p><sup>g</sup> Subjects who meet the definition of treatment failure to BMN 270 therapy after Week 52 may omit the Q4W and Q6W visits during Years 2-5, and must attend only the Q12W and End of Year visits. <u>Subjects who are not attending the Q4W/Q6W visits during Years 2-5 may receive a scheduled monthly follow-up telephone call from the site to ask about adverse events, concomitant medications, and bleeding events/FVIII replacement usage.</u> Such subjects following the abbreviated schedule who have not yet cleared vector shedding in <del>all fluids</del> <u>one or more matrices</u> must still provide samples <u>in the uncleared matrix</u> Q4W (during Year 2) or Q6W (during Years 3-5) until vector shedding has been cleared, either by reporting to the site to provide samples or by providing those samples to a MN professional.</p> <p><sup>h</sup> <u>An optional liver biopsy may be performed at any time between Years 2-5 of the study. The optional biopsy may be triggered by a FVIII activity decline by &gt; 50% from steady-state, over 2 consecutive measurements, or by a sustained ALT rise &gt; ULN. If neither triggered is observed, the optional biopsy may be performed at the end of Year 5. Subjects should fast for at least 8 hours prior to liver ultrasound and optional liver biopsies.</u></p> |           |
| Table 9.1.6/Schedule of Events (Steroids) (Notes)             | <p><sup>b</sup> Following initiation or completion of steroid regimen, if a recurrence of ALT values <math>\geq 1.5 \times \geq</math> ULN or <math>&gt; ULN \&amp; &gt; 2 \times \geq</math> <u>1.5x</u> baseline value is reported, steroid management decisions will based on discussions between the Investigator and Medical Monitor. Modification of the steroid regimen may take into consideration possible confounders for the ALT elevation, relationship between increases in ALT and FVIII activity, ALT/FVIII levels post steroid initiation, and adverse events related to steroid dosing. Guidance for tapering oral corticosteroid dosing can be found in Section 9.4.8.2.</p>  | 9         |
| <u>Table 9.1.7/Schedule of Events (Optional Liver Biopsy)</u> | <u>Table 9.1.7 has been added to the protocol as part of this amendment.</u>  | 10        |
| Section 9.3.1/ Inclusion Criteria                             | <p>Individuals eligible to participate in this study must meet all of the following inclusion criteria:</p> <p>6. Sexually active participants must agree to use an acceptable method of effective contraception, either double-barrier contraception (ie, condom + diaphragm; or condom or diaphragm + spermicidal gel or foam) or their female partner either using hormonal contraceptives or having an intrauterine device. Participants must agree to contraception use for at least 12 weeks post-infusion; after 12 weeks, subjects may stop contraception use only if they have had 3 consecutive semen samples with <del>no detectable</del> <u>viral vector DNA below the limit of detection.</u></p>   | 4, 10     |





| Section No./Title   | Revision  | Rationale        |
|---|---|------------------|
| <p><u>Section 9.3.2.1/ Optional Liver Biopsy Inclusion and Exclusion Criteria</u></p> | <p>Individuals eligible for the optional liver biopsy must meet the following inclusion criterion:</p> <ol style="list-style-type: none"> <li>1. <u>Able to sign informed consent and comply with requirements for the optional liver biopsy</u></li> <li>2. <u>Documentation of FVIII activity <math>\geq</math> 50 IU/dL (or higher, depending on local guidelines and/or Investigator discretion) within 24 hours prior to the liver biopsy being performed (FVIII activity levels should be assessed at the local laboratory). Subjects may be treated with additional exogenous FVIII replacement products in order to increase their FVIII levels activity to an appropriate level, under the supervision/instruction of the Investigator.</u></li> </ol> <p>Individuals who meet any of the following exclusion criteria will not be eligible for the optional liver biopsy:</p> <ol style="list-style-type: none"> <li>1. <u>Any condition that, in the opinion of the Investigator or a hepatologist/radiologist would make liver biopsy contraindicated. This includes (but is not limited to) abnormalities detected on liver ultrasound performed within 28 days of procedure, or prior liver ultrasound result within 90 days that would preclude safe performance of the biopsy.</u></li> </ol> |                  |
| <p>Section 9.3.3/Removal of Subjects from Treatment or Assessment</p>                 | <p><u>Subjects may be considered lost to follow-up if the subject has missed 3 consecutive visits in the study and has failed to communicate a reason for this to the site. In addition, the site has documented at least 4 attempted contacts by key research personnel to reach the subject without success in the following manner:</u></p> <ul style="list-style-type: none"> <li>• <u>2 attempts by telephone or email (if possible); then</u></li> <li>• <u>If telephone/email contacts are unsuccessful, 2 attempts must be made by certified letter or by appropriate local process.</u></li> </ul> <p><u>Where communication has been made by phone, this should be documented in the subject source notes.</u></p>  | <p>16</p>        |
| <p>Section 9.4.7/Blinding</p>   | <p><u>In order to minimize bias and to preserve the scientific and business integrity of the single-arm and open-label study, a data access plan (DAP) has been implemented. This document provides guidelines for accessing post-treatment study data and applies to study team members, including personnel from within BioMarin, from external vendors and service providers, from the DMC, and from study sites. Role-based access control to study data, both individual patient-level data values as well as aggregated summaries of longitudinal data in an individual patient or across multiple patients, has been implemented to minimize potential bias and achieve appropriately controlled decision-making, while preserving operational efficiency. It is enforced by the DAP that individuals who are designated to have knowledge of the key efficacy variables (FVIII activity, FVIII usage, and bleeding counts) will not make or influence decisions that would alter the study design or conduct, or the collection or analysis of the key efficacy variables so as to bias the studies' key efficacy results.</u></p>  | <p>1</p>         |
| <p>Section 9.4.8/Prior and Concomitant Medications</p>                                | <p>The following medications are prohibited starting 30 days before Screening and through the end of the study, and the Sponsor must be notified if a subject receives any of these during the study:</p> <ul style="list-style-type: none"> <li>• <del>Systemic immunosuppressive agents, except for corticosteroids</del></li> </ul>  | <p>3, 15, 22</p> |



| Section No./Title  | Revision  | Rationale           |
|--|---|---------------------|
|  | <p>• <del>Lamivudine</del></p> <p>The following medications should be avoided, starting 30 days prior to and for at least 52 weeks after BMN 270 infusion and minimized throughout the remaining duration of the study.</p> <ul style="list-style-type: none"> <li>• Medications which may be hepatotoxic, <u>including isotretinoin and dextroamphetamine/amphetamine</u></li> <li>• <u>Medications which may reduce or increase the plasma concentration of corticosteroids</u></li> </ul> <p><u>Subjects should be counseled to avoid starting potentially hepatotoxic therapies and to inform the Investigator of any new medications prescribed by other physicians. Investigators should carefully consider both the mechanism of action and potential hepatotoxicity of any new medication prior to initiation. If a potentially concerning new medication is started, Investigators should closely monitor both FVIII activity and ALT levels (eg, weekly to every 2 weeks for the first month) in order to determine if any detrimental effects on the efficacy or safety of BMN 270 have occurred. If co-medications are required during the course of the study, where possible, please check the National Center for Biotechnology Information LiverTox website for potential hepatotoxicity issues prior to prescribing (NCBI, 2020).</u></p>  |                     |
| <p>Section 9.4.8.2/<br/>Therapeutic<br/>Glucocorticoid<br/>Treatment and/or<br/><u>Immunosuppressive<br/>Agent Treatment of<br/>Elevated Hepatic<br/>Transaminases</u></p> | <p><u>Refer to corticosteroid prescription guidelines for recommended monitoring for, and management of, potential side effects of corticosteroids, including guidance on medications that should be avoided during corticosteroid treatment.</u></p> <p>Therapeutic oral corticosteroids (prednisone or converted equivalent) should be initiated when either of the following occurs post-BMN 270 infusion in any subject and after consultation with the Medical Monitor (or their designee):</p> <ul style="list-style-type: none"> <li>• <u>ALT &gt; ULN or <math>\geq 1.5x</math> ULN or ALT &gt; ULN &amp; <math>\geq 2x</math> baseline value in 2 consecutive assessments within 72 hours and alternative etiologies have been ruled out, or ALT <math>\geq 3x</math> ULN in 2 consecutive assessments within 48 hours (refer to Table 9.7.8.3.2)</u> <ul style="list-style-type: none"> <li>○ Whenever possible, a confirmatory lab draw for ALT should be performed, along with FVIII activity, prior to initiating oral corticosteroids.</li> <li>○ Corticosteroids may be delayed if elevations in ALT are clearly not related to BMN 270 (eg, elevated ALT with concurrent increase in CPK due to intensive exercise)</li> <li>○ <u>Alternative immunosuppressive agents may also be considered for use on a case-by-case basis and following consultation with the Medical Monitor (eg, if prolonged corticosteroid use is contraindicated).</u></li> </ul> </li> </ul> <p>...</p> <p>Following initiation or completion of therapeutic oral corticosteroids, if ALT elevation <u><math>\geq 1.5x</math> (eg, &gt; ULN or ALT <math>\geq</math> ULN &amp; <math>\geq 2x</math> <math>\geq 1.5x</math> baseline value) is reported, corticosteroid management decisions will be based on discussions between the Investigator and</u></p> | <p>3, 9, 14, 22</p> |



| Section No./Title  | Revision   | Rationale |
|--|--|-----------|
|  | <p>Medical Monitor. Modification of the corticosteroid regimen may take into consideration possible confounders for the ALT elevation and impact on FVIII expression.</p> <p>Management and monitoring of reactions to corticosteroids should be determined by the Investigator’s clinical judgment in consultation with the Sponsor’s Medical Monitor. This includes the contraindicated use of NSAIDs during corticosteroid treatment and specific monitoring not already covered by the schedule of events. The use of COX-2 inhibitors, while not contraindicated during corticosteroid treatment, should be limited, if possible. Practical management to prevent complications related to oral corticosteroid therapy may be undertaken at the discretion of the Investigator (eg, evaluation of glucose intolerance, hyperlipidemia etc.). <u>Alternative, non-steroidal systemic immunosuppressive agents may be used, following a discussion between the Investigator and the Medical Monitor, should corticosteroid use be deemed by an Investigator to be clinically ineffective, not tolerated, and/or contraindicated.</u> Hepatitis B status and HCV viral load will be rechecked 6 weeks after the start of oral corticosteroid/<u>immunosuppressive agent</u> treatment and then 1 week and 13 weeks after the completion of oral corticosteroid/<u>immunosuppressive agent</u> treatment in subjects with a history of hepatitis B or hepatitis C. All adverse events (including any adverse events suspected to be caused by or related to corticosteroid/<u>immunosuppressive agent</u> use) should be reported as outlined in Section 10 of the protocol.</p> <p><u>Subjects on corticosteroids should receive appropriate counselling and support regarding side effects from the Investigator or the treating institution (eg, listings of side effects and when to notify carers, wallet card for emergencies if on steroids, etc.). Additional management, including the co-prescription of additional medications to prevent complications related to corticosteroid therapy, may be undertaken at the discretion of the investigator, including, but not limited to, prophylaxis against the occurrence of gastric ulcers, osteoporosis, and infections. The above guidance should also be followed in the event that an alternative immunosuppressive agent is used, as applicable.</u></p> |           |
| Table 9.4.8.2.1/<br>Adjustments to<br>Corticosteroid Regimen | Table 9.4.8.2.1 has been updated consistent with changes elsewhere in this section.  | 14        |
| Section 9.6/Dietary or<br>Other Protocol<br>Restrictions     | <p>There are no dietary or other protocol restrictions for this study. Alcohol should be avoided for the first 52 weeks of the study, and particularly within 48 hours prior to lab work. <u>Alcohol use should be minimized throughout the remaining duration of the study.</u></p> <p>Subjects should be advised to abstain from any blood or sperm donation after BMN 270 infusion, until there is no further evidence of vector shedding from PCR analysis of samples. <u>Subjects should also abstain from organ donation.</u></p>  | 22        |
| Section 9.7.2.1/FVIII<br>Activity                            | Subjects who do not respond to BMN 270 treatment (ie treatment failure, manifesting as either failure to achieve FVIII activity $\geq$ 5 IU/dL by Week 52 or inability to maintain independence from prophylactic FVIII replacement therapy due to joint bleeding episodes, in the judgment of the Investigator) may, at the Investigator’s discretion and after discussion with the Medical Monitor or  | 12        |



| Section No./Title                                    | Revision  | Rationale |
|--|---|-----------|
|  | <p>Sponsor-designated Data Monitor, follow an abbreviated visit schedule after Week 52 of the study by attending only the Q12W and End of Year visits during Years 2-5. <u>Subjects who are not attending the Q4W/Q6W visits during Years 2-5 may receive a scheduled monthly follow-up telephone call from the site to ask about adverse events, concomitant medications, and bleeding events/FVIII replacement usage.</u></p>   |           |
| <p>Section 9.7.4.1/PROs</p>                          | <p>The Patient Reported Outcomes, Burdens, and Experiences (PROBE) questionnaire is designed to investigate and directly probe patient perspectives on outcomes they deem relevant to their life and care. PROBE aims to develop a new global tool to enhance the direct patient-voice in health care decision-making (Chai-Adisaksopha, 2017). <u>PROBE data collected in 270-301 will be shared with the Patient Outcomes Research Group (PORG) in order to facilitate validation of the tool; subjects may opt out of having their data used for this purpose.</u> A sample copy of the PROBE questionnaire and additional information are provided in the On Site File Binder.</p>  | <p>22</p> |
| <p><u>Section 9.7.7.1/ Optional Liver Biopsy</u></p> | <p><u>Subjects electing to undergo an optional liver biopsy are required to consent to the procedure and collection of tissue in the study ICF. The analysis of the optional liver biopsy is considered exploratory. Subject who elect to proceed will have a liver biopsy performed during Year 1 post-infusion, at or around Week 52, and/or during Years 2-5. Additional liver biopsies at times deemed to be clinically relevant (eg, decreasing FVIII at a time of increased ALT) may be pursued. Subjects will be asked to consent to the procedure for each liver biopsy performed during the study.</u></p> <p><u>Subjects who consent to the procedure will have a liver biopsy via either transjugular or percutaneous (ultrasound-guided) route, according to the standard procedures of the institution. Two tissue cores will be harvested in the context of the optional liver biopsy. Subjects will be required to observe an 8-hour fasting period before the procedure.</u></p> <p><u>Within 24 hours prior to the biopsy being performed, subjects must have a documented FVIII activity level of <math>\geq 50</math> IU/dL (or higher, depending on local guidelines and/or investigator discretion). FVIII activity levels for this purpose should be assessed at the local laboratory within 7 days before the biopsy and again on the day the biopsy, prior to the procedure. As needed, subjects may be treated with additional exogenous FVIII replacement products in order to increase their FVIII activity levels to an appropriate level, under the supervision/instruction of the investigator, to ensure the safety of the subject during the procedure. This exogenous FVIII usage (if performed) should be recorded in the eCRF FVIII infusion pages under the category "Surgery/Procedure".</u></p> <p><u>Details on required procedures for the optional liver biopsy are outlined in Table 9.1.7. Subjects consenting to participate to the optional liver biopsy will undergo pre-biopsy assessments at least 28 days before the procedure, as follows:</u></p> <ul style="list-style-type: none"> <li>• <u>Physical examination</u></li> <li>• <u>Hematology, coagulation, chemistry assessments</u></li> </ul> | <p>10</p> |



| Section No./Title                                | Revision  | Rationale |
|--|---|-----------|
|  | <ul style="list-style-type: none"> <li>• <u>Liver tests</u></li> <li>• <u>Liver ultrasound (subject should fast at least 8 hours prior to ultrasound)</u></li> <li>• <u>FibroScan</u></li> </ul> <p><u>Subjects consenting to participate to the optional liver biopsy will undergo pre-biopsy assessments at least 7 days before the procedure, as follows:</u></p> <ul style="list-style-type: none"> <li>• <u>Local FVIII activity level assessment</u></li> <li>• <u>Pre-biopsy consultation (with hepatologist and/or radiologist)</u></li> </ul> <p><u>On the day of the biopsy, brief physical examination and liver and blood tests should be performed before the procedure (including hematology, coagulation, and chemistry). FVIII activity assessment should also be performed to ensure the subject has sufficient FVIII activity to protect against procedure-related bleeding (as discussed above). LT assessment and a whole blood draw for PBMC collection should be performed on the biopsy day or ± 1 week from the biopsy day.</u></p> <p><u>The optional liver biopsy should be performed in the morning if feasible, and the biopsy procedure and follow-up care should be done according to the local standard of care. Additional details for handling the biopsy specimens are provided in the Laboratory Manual.</u></p> <p><u>Following completion of the biopsy, the subject should remain under observation in the clinic for at least 4-6 hours. Overnight post-procedure observation may be done at the investigator’s discretion and/or according to local guidelines.</u></p> <p><u>Clinically significant findings reported from the histopathological analysis of the biopsy sample are subject to AE reporting (Section 10). Such findings should be further assessed and followed as clinically appropriate to manage the subject’s medical care. A hepatologist and/or other specialist clinicians should be consulted if required. In the event that fibrotic changes are observed on the biopsy sample, additional liver ultrasound, FibroScan and/or Enhanced Liver Fibrosis (ELF) testing (as regionally available and/or approved by HA) may be considered at the discretion of the investigator and/or hepatologist.</u></p> |           |
| Section 9.7.8.2/ Clinical Laboratory Assessments | <p><del>During Years 2-5,</del> At applicable sites, certain study assessments designed in the Schedule of Events may be performed by a mobile nursing (MN) professional at the patient's home or another suitable location, such as their school or office, to improve access and convenience for patients participating in the study. The Sponsor may select a healthcare company that will be responsible for providing MN services for participating sites (the MN vendor). The MN vendor is responsible for ensuring that all MN professionals are licensed, qualified, and in good standing, as per applicable regulations, and that appropriate background checks have been performed. If the investigator at a participating site determines that MN services are appropriate for a patient and the patient gives written informed consent to participate in MN visits, the MN network will communicate with the patient and the patient’s site.</p>  | 7, 8      |



| Section No./Title                                  | Revision  | Rationale |
|--|---|-----------|
|  | <p><u>For all subjects, MN visits will be allowed for the Q4W (during Year 2) and Q6W (during Years 3-5) visits; the Q12W visits and End of Year visits during Years 2-5 will not be performed by an MN professional but will be done at the study site. For subjects who have enrolled in 270-301 following participation in 270-902, MN visits may also be available during Year 1 at Weeks 5, 7, 9, 11, 13, 15, 17, 19, 21, 23, 25, 27, 29, 30, 31, 33, 34, 35, 38, 42, 46, and 50 (as indicated in the Schedule of Events). At visits not specifically designated for MN eligibility (ie, visits where the subject is intended to return to the site for assessment), MN services may be used if the subject is unable to attend the site to complete the study visit during the acceptable window for that visit, upon prior approval by the Medical Monitor and discussion between the Medical Monitor and Investigator.</u></p> <p><u>In the event that neither a lab-only visit or MN visit can be conducted for a post-infusion visit, the site should telephone the subject to collect adverse event, concomitant medication, and diary data (bleeding events and FVIII usage), in the interest of monitoring subject safety and welfare.</u></p> |           |
| Table 9.7.8.2.1/ Clinical Laboratory Tests (Notes) | *ABO blood typing assessment should be performed <del>as part of the hematology assessment</del> (at Baseline, or at another regularly scheduled visit prior to the end of the subject’s participation in the study).   | 22        |
| Section 9.7.8.3/Liver and Hepatitis Testing        | <p>Subjects will be screened for evidence of previous or active hepatitis B or hepatitis C infection at Screening; hepatitis B screening should include HBsAg, HBsAb, and HBcAb. Subjects with documented results showing an absence of active hepatitis B or hepatitis C infection (as measured by positive <del>surface antigen</del> <u>DNA</u> for hepatitis B or positive RNA testing for hepatitis C) 30 days prior to providing signed informed consent do not need to repeat those tests during the screening period.</p> <p>...</p> <p>Elevated ALT levels (above the upper limit of normal range) should be evaluated according to the following plan: <u>(note that these evaluations may indicate additional testing of LTs and FVIII levels at unscheduled visits; these unscheduled laboratory tests may be completed by a mobile nursing professional at sites where the use of MN services has been approved):</u></p>  | 6, 22     |
| Table 9.7.8.3.2/ Evaluation of ALT Elevations      | Table 9.7.8.3.2 has been updated consistent with changes elsewhere in the protocol.   | 9, 22     |
| Section 9.7.8.6/Vector Shedding                    | Vector shedding will also be extensively studied in the present clinical trial, at the time points indicated in Table 9.1.1, Table 9.1.2, Table 9.1.3, Table 9.1.4, and Table 9.1.5. Testing will continue until at least 3 consecutive <del>negative</del> <u>results below the limit of detection</u> are obtained. <u>If a positive result is obtained in a matrix after 3 consecutive results below the limit of detection have already been recorded, testing in that matrix should restart and continue until an additional 3 consecutive results below the limit of detection have been obtained in order to confirm clearance.</u>  | 4, 5, 22  |



| Section No./Title              | Revision   | Rationale |
|--------------------------------|--|-----------|
|                                | <p>Testing of semen will continue at least through Week 12, even if 3 consecutive <del>negative</del> results <u>below the limit of detection</u> have been recorded in that compartment prior to that time point. Subjects who have not had 3 consecutive <del>negative</del> semen samples <u>below the limit of detection</u> by Week 52 should continue to have PCR testing in semen every 4 weeks (during Year 2) and every 6 weeks (during Years 3-5) until 3 consecutive <del>negative</del> samples <u>below the limit of detection</u> are documented (or upon consultation between the Investigator and Medical Monitor).</p> <p>Subjects who meet the definition of treatment failure and wish to follow an abbreviated schedule (refer to Section 12.7) but who have not cleared vector shedding from <del>all fluids</del> <u>semen</u> must still provide samples for assessment every 4 weeks (during Year 2) or every 6 weeks (during Years 3-5) until vector shedding has cleared. Such subjects may provide samples on the designated study visit dates either at the sites or through use of a MN professional.</p> <p>Samples may be fractionated prior to shedding analysis in order to better characterize the presence, structure, and location of vector DNA and/or vector capsid within each matrix. If needed, the fractionation may be performed with samples collected specifically for shedding analysis (saliva, blood, semen, urine, <del>feces</del> stool). Alternatively, the vector DNA characterization during shedding analysis may utilize already fractionated exploratory samples obtained from the above biofluids, such as exploratory plasma samples, exploratory PBMC samples, and red blood cells recovered during PBMC/plasma isolations.</p> <p>...</p> <p>Contraception use may need to be extended beyond <del>26</del> <u>12</u> weeks in individual subjects based on observed vector shedding in semen. After <del>26</del> <u>12</u> weeks, subjects may stop contraception use only if they have had 3 consecutive <del>negative</del> semen samples <u>with viral vector DNA below the limit of detection</u> (upon consultation between the Investigator and Medical Monitor).</p> |           |
| Section 10.2.1/EOSI            | <p>The following EOSI need to be reported to the Sponsor within 24 hours of site awareness, irrespective of seriousness, severity or causality:</p> <ul style="list-style-type: none"> <li>• Elevation of ALT <math>\geq 1.5 \times</math> ULN or <del>ALT &gt; ULN &amp; &gt;2x</del> <math>\geq 1.5 \times</math> baseline value, regardless of whether that elevation triggers an initiation or modification of oral corticosteroid treatment</li> <li>• <u>Events potentially meeting the criteria for Hy's law (ALT or AST elevation <math>\geq 3 \times</math> ULN plus total bilirubin <math>\geq 2 \times</math> ULN)</u></li> </ul>   | 9, 11     |
| Section 10.3.3.3/<br>Causality | <p>The Investigator will determine the relationship of an AE to the study drug <u>and/or corticosteroids and/or other immunosuppressant agents and</u> will record it on the source documents and AE eCRF. To ensure consistency of causality assessments, Investigators should apply the guidance in Table 10.3.3.3.1.</p> <p>Factors suggestive of a causal relationship could include (but are not limited to):</p>   | 13        |



| Section No./Title                                      | Revision   | Rationale |
|--|--|-----------|
|  | <ul style="list-style-type: none"> <li>• Absence of event prior to study drug <u>and/or corticosteroid and/or other immunosuppressant agent</u> exposure</li> <li>• Known relationship to underlying mechanism of study drug <del>action</del> <u>and/or corticosteroid and/or other immunosuppressant agent action</u></li> <li>• Abatement of AE with discontinuation of study drug <u>and/or corticosteroids and/or other immunosuppressant agents</u>, and/or recurrence of AE with reintroduction of study drug <u>and/or corticosteroids and/or other immunosuppressant agents</u></li> </ul>  |           |
| Table 10.3.3.3.1/<br>Causality Attribution<br>Guidance | Table 10.3.3.3.1 has been updated consistent with changes made elsewhere in this section.  | 13        |
| Section 10.9/Contact<br>Information                    | <p>Contact information for the Medical Monitor is as follows:</p> <p>Name: <del>Benjamin Kim</del> <u>Adebayo Lawal, MD, MPhil-MSc, MBA</u></p> <p>Address: 105 Digital Drive<br/>Novato, CA 94949 USA</p> <p>Phone: +1 (415) 996-<del>2923</del> <u>2845</u></p> <p>E-mail: <del>benjamin.kim</del> <u>adebayo.lawal@bmrn.com</u></p>   | 20        |
| Section 12.3/Baseline<br>Visit                         | <p>The following procedures will be performed during the Baseline Period:</p> <ul style="list-style-type: none"> <li>• Blood chemistry, hematology, and coagulation tests (refer to Table 9.7.8.2.1) <ul style="list-style-type: none"> <li>○ ABO blood typing assessment should be performed <del>as part of the hematology assessment</del> (at Baseline, or at another regularly scheduled visit prior to the end of the subject's participation in the study).</li> </ul> </li> </ul>  | 22        |
| Section 12.4/Day 1 visit                               | <p>The following procedures will be performed during the BMN 270 Infusion Visit:</p> <ul style="list-style-type: none"> <li>• <del>Exploratory biomarker assessments</del></li> </ul>  | 22        |
| Section 12.5/Weeks 1-26                                | <p>After BMN 270 has been infused, subjects will return to the study site every week (± 48 hours) during Weeks 1-26. For subjects who have enrolled in 270-301 following participation in 270-902, optional MN services or shortened lab draw-only site visits may be conducted for the visits at Week 5, Week 7, Week 9, Week 11, Week 13, Week 15, Week 17, Week 19, Week 21, Week 23, and Week 25. <u>At visits not specifically designated for MN eligibility (ie, visits where the subject is intended to return to the site for assessment), MN services may be used if the subject is unable to attend the site to complete the study visit during the acceptable window for that visit, upon prior approval by the Medical Monitor and discussion between the Medical Monitor and Investigator. In the event that neither a lab-only visit or MN visit can be conducted, the site should telephone the subject to collect adverse event, concomitant medication, and diary data (bleeding events and FVIII usage).</u></p> | 7, 8, 10  |



| Section No./Title  | Revision   | Rationale |
|--|--|-----------|
|  | <u>During Year 1, subjects may consent to an optional liver biopsy. If such a procedure is planned, refer to Section 12.9 for assessments related to performing the liver biopsy.</u>  |           |
| Section 12.5.1/Once per Week, Weeks 1-26                   | <p>The following procedures will be performed at one visit per week from Weeks 1 through 26:</p> <ul style="list-style-type: none"> <li>• Liver Tests (refer to Table 9.7.8.3.1) <ul style="list-style-type: none"> <li>○ LTs may be monitored more or less frequently (and in particular when ALT values are <math>\geq 1.5 \times</math> ULN or <math>&gt; \text{ULN} \&amp; \gt 2 \times \geq 1.5 \times</math> baseline value) based on discussion between the Medical Monitor and the Investigator and review of subject data, but LTs will be monitored at least twice weekly during periods when a subject's ALT is <math>\geq 3 \times</math> ULN.</li> </ul> </li> </ul>  | 9         |
| Section 12.5.2/Day 4                                       | <p>On Day 4 of Week 1, the following procedures will be performed:</p> <ul style="list-style-type: none"> <li>• <u>Assessment of Adverse Events and Concomitant Medications (including review of subject diary for bleeding and FVIII use)</u></li> </ul>  | 22        |
| Section 12.5.6/Weeks 2, 3, 4, 6, 8, 12, 16, 20, 24, and 26 | <p>At Weeks 2, 3, 4, 6, 8, 12, 16, 20, 24, and 26, the following procedure will be performed:</p> <ul style="list-style-type: none"> <li>• PCR of vector DNA in blood, saliva, urine, semen, and stools <ul style="list-style-type: none"> <li>○ Collection to occur until at least 3 consecutive <del>negative</del> results <u>below the limit of detection</u> are obtained. Semen samples should continue to be collected and tested through Week 12, even if 3 consecutive <del>negative</del> results <u>below the limit of detection</u> in that compartment have been recorded prior to that time point.</li> </ul> </li> </ul>  | 4         |
| Section 12.6/Weeks 27-52                                   | <p>During Weeks 27-36, subjects will return to the study site weekly (<math>\pm 48</math> hours). During Weeks 37-52, subjects will return to the study site every 2 weeks (Week 38, 40, 42, 44, 46, 48, 50, and 52) (<math>\pm 1</math> week). For subjects who have enrolled in 270-301 following participation in 270-902, optional MN services or shortened lab draw-only site visits may be conducted at Week 27, Week 29, Week 30, Week 31, Week 33, Week 34, Week 35, Week 38, Week 42, Week 46, and Week 50. <u>At visits not specifically designated for MN eligibility (ie, visits where the subject is intended to return to the site for assessment), MN services may be used if the subject is unable to attend the site to complete the study visit during the acceptable window for that visit, upon prior approval by the Medical Monitor and discussion between the Medical Monitor and Investigator. In the event that neither a lab-only visit or MN visit can be conducted, the site should telephone the subject to collect adverse event, concomitant medication, and diary data (bleeding events and FVIII usage).</u></p> <p><u>During Year 1, subjects may consent to an optional liver biopsy. If such a procedure is planned, refer to Section 12.9 for assessments related to performing the liver biopsy.</u></p> | 7, 8, 10  |
| Section 12.6.1/Every Visit (Weeks 27-52)                   | At every visit (Weeks 27-36, 38, 40, 42, 44, 46, 48, 50, and 52), the following procedures will be performed:  | 9         |



| Section No./Title                               | Revision   | Rationale |
|---|--|-----------|
|   | <ul style="list-style-type: none"> <li>• Liver Tests (refer to Table 9.7.8.3.1)                             <ul style="list-style-type: none"> <li>○ LTs may be monitored more or less frequently (and in particular when ALT values are <math>\geq 1.5 \times</math> ULN or <math>&gt; ULN</math> <del>&amp; <math>\geq 2 \times</math> <math>\geq 1.5 \times</math></del> baseline value) based on discussion between the Medical Monitor and the Investigator and review of subject data, but LTs will be monitored at least twice weekly during periods when a subject's ALT is <math>\geq 3 \times</math> ULN.</li> </ul> </li> </ul>   |           |
| Section 12.6.2/Weeks 28, 30, 32, 36, 44, and 52 | At Weeks 28, <del>30</del> , 32, 36, 44, and 52, the following procedure will be performed: <ul style="list-style-type: none"> <li>• PBMC collection</li> </ul>  | 2         |
| Section 12.6.5/Weeks 32, 36, 40, 44, 48, and 52 | At Weeks 32, 36, 40, 44, 48, and 52, the following procedures will be performed: <ul style="list-style-type: none"> <li>• PCR of vector DNA in blood, saliva, urine, semen, and stools                             <ul style="list-style-type: none"> <li>○ Sample testing to occur until at least 3 consecutive <del>negative sample results</del> <u>below the limit of detection</u> have been obtained. Subjects who have not had 3 consecutive <del>negative semen samples</del> <u>below the limit of detection</u> by Week 52 should continue to have PCR testing of semen every 4 weeks until 3 consecutive <del>negative samples</del> <u>below the limit of detection</u> are documented (or upon consultation between the Investigator and Medical Monitor).</li> </ul> </li> </ul>   | 4         |
| Section 12.6.8/Week 52                          | At Week 52, the following optional procedure may be performed: <ul style="list-style-type: none"> <li>• <u>Optional liver biopsy (refer to Section 12.9 for assessments related to liver biopsy)</u></li> </ul>  | 10        |
| Section 12.7/Years 2-5                          | During Years 2-5, at applicable sites, certain study assessments may be performed by a mobile nursing (MN) professional at the patient's home or another suitable location, such as their school or office, to improve access and convenience for patients participating in the study. The Sponsor may select a healthcare company that will be responsible for providing MN services for participating sites (the MN vendor). The MN vendor is responsible for ensuring that all MN professionals are licensed, qualified, and in good standing, as per applicable regulations, and that appropriate background checks have been performed. If the investigator at a participating site determines that MN services are appropriate for a patient and the patient gives written informed consent to participate in MN visits, the MN network will communicate with the patient and the patient's site. MN visits will be allowed for the Q4W (during Year 2) and Q6W (during Years 3-5) visits; the Q12W visits and End of Year visits during Years 2 5 will not be performed by an MN professional but will be done at the study site. <u>At visits not specifically designated for MN eligibility (ie, visits where the subject is intended to return to the site for assessment), MN services may be used if the subject is unable to attend the site to complete the study visit during the acceptable window for that visit, upon prior approval by the Medical Monitor and discussion between the Medical Monitor and Investigator.</u> | 7, 12     |



| Section No./Title                               | Revision  | Rationale    |
|---|---|--------------|
|   | <p>Subjects who do not respond to BMN 270 treatment (ie, treatment failure, manifesting as either failure to achieve FVIII activity <math>\geq 5</math> IU/dL by Week 52 or inability to maintain independence from prophylactic FVIII replacement therapy due to joint bleeding episodes, in the judgment of the Investigator) may, at the Investigator’s discretion and after discussion with the Medical Monitor or Sponsor-designated Data Monitor, follow an abbreviated visit schedule after Week 52 of the study by attending only the Q12W and End of Year visits during Years 2-5. <u>Subjects who are not attending the Q4W/Q6W visits during Years 2-5 may receive a scheduled monthly follow-up telephone call from the site to ask about adverse events, concomitant medications, and bleeding events/FVIII replacement usage.</u></p>   |              |
| <p>Section 12.7.1/Year 2 – Every 4 Weeks</p>    | <p>During Year 2, every 4 weeks (<math>\pm 2</math> weeks), the following procedures will be performed:</p> <ul style="list-style-type: none"> <li>• Liver Tests (refer to Table 9.7.8.3.1)                             <ul style="list-style-type: none"> <li>○ LTs may be monitored more or less frequently (and in particular when ALT values are <del><math>\geq 1.5x</math></del> <math>\geq 1.5x</math> ULN or <del><math>&gt; 2x</math></del> <math>&gt; 1.5x</math> baseline value) based on discussion between the Medical Monitor and the Investigator and review of subject data, but LTs will be monitored at least twice weekly during periods when a subject’s ALT is <math>\geq 3x</math> ULN.</li> </ul> </li> <li>• PCR of vector DNA in <del>blood, saliva, urine, semen, and stools</del> (if required)                             <ul style="list-style-type: none"> <li>○ <del>Sample testing during Year 2 is not required if at least 3 consecutive samples are negative during the Post-Infusion Follow-Up period in Weeks 1–52.</del> Subjects who have not had 3 consecutive <del>negative</del> semen samples below the limit of detection by Week 52 should continue to have PCR testing of semen every 4 weeks during <del>Years</del> Year 2 until 3 consecutive <del>negative</del> samples below the limit of detection are documented (or upon consultation between the Investigator and Medical Monitor).</li> <li>○ Subjects who meet the definition of treatment failure and wish to follow an abbreviated schedule but who have not cleared vector shedding <del>from all fluids in semen</del> must still provide <u>semen</u> samples for assessment every 4 weeks during Year 2 until vector shedding has cleared. Such subjects may provide samples on the designated study visit dates either at the sites or through use of a MN professional.</li> </ul> </li> </ul> | <p>9, 19</p> |
| <p>Section 12.7.2/Years 3-5 – Every 6 Weeks</p> | <p>During Years 3-5, every 6 weeks (<math>\pm 2</math> weeks), the following procedures will be performed:</p> <ul style="list-style-type: none"> <li>• Liver Tests (refer to Table 9.7.8.3.1)                             <ul style="list-style-type: none"> <li>○ LTs may be monitored more or less frequently (and in particular when ALT values are <del><math>\geq 1.5x</math></del> <math>\geq 1.5x</math> ULN or <del><math>&gt; 2x</math></del> <math>&gt; 1.5x</math> baseline value) based on discussion between the Medical Monitor and the Investigator and review of subject data, but LTs will be monitored at least twice weekly during periods when a subject’s ALT is <math>\geq 3x</math> ULN.</li> </ul> </li> <li>• PCR of vector DNA in <del>blood, saliva, urine, semen, and stools</del> (if required)</li> </ul>  | <p>9, 19</p> |



| Section No./Title   | Revision   | Rationale        |
|---|--|------------------|
|   | <ul style="list-style-type: none"> <li>○ <del>Sample testing during Years 3-5 is not required if at least 3 consecutive samples are clear by the end of Year 2. Subjects who have not had 3 consecutive <u>negative</u> semen samples <u>below the limit of detection</u> by the end of Year 2 should continue to have PCR testing of semen every 6 weeks during Years 3-5 until 3 consecutive <u>negative</u> samples <u>below the limit of detection</u> are documented (or upon consultation between the Investigator and Medical Monitor).</del></li> <li>○ Subjects who meet the definition of treatment failure and wish to follow an abbreviated schedule but who have not cleared vector shedding <del>from all fluids</del> in semen by the end of Year 2 must still provide <u>semen</u> samples for assessment every 6 weeks during Years 3-5 until vector shedding has cleared. Such subjects may provide samples on the designated study visit dates either at the sites or through use of a MN professional.</li> </ul>  |                  |
| <p>Section 12.7.3/Years 2-5 – Every 12 Weeks and End of Year Visits</p> | <p>At the every 12 week and End of Year visits, the following procedures will be performed:</p> <ul style="list-style-type: none"> <li>• Liver Tests (refer to Table 9.7.8.3.1)                             <ul style="list-style-type: none"> <li>○ LTs may be monitored more or less frequently (and in particular when ALT values are <math>\geq 1.5 \times</math> ULN or <math>&gt; ULN</math> &amp; <math>&gt; 2 \times \geq 1.5 \times</math> baseline value) based on discussion between the Medical Monitor and the Investigator and review of subject data, but LTs will be monitored at least twice weekly during periods when a subject’s ALT is <math>\geq 3 \times</math> ULN.</li> </ul> </li> <li>• PCR of vector DNA in blood, saliva, urine, semen, and stools (if required)                             <ul style="list-style-type: none"> <li>○ <del>Sample testing during Years 2-5 is not required in a matrix if at least 3 consecutive samples are <u>negative</u> below the limit of detection in that matrix during the Post-Infusion Follow-Up period in Weeks 1-52. <u>Subjects who have not had 3 consecutive negative semen samples by Week 52 should continue to have PCR testing of semen every 4 weeks (during Year 2) or every 6 weeks (during</u></del></li> </ul> </li> <li>• <u>Optional liver biopsy (Years 3- 2-5) (refer to Section 12.9 until 3 consecutive negative samples are documented (or upon consultation between the Investigator and Medical Monitor), for assessments related to liver biopsy)</u></li> </ul> | <p>9, 10, 19</p> |
| <p>Section 12.9/Optional Liver Biopsy</p>                               | <p><u>Details on required procedures for the optional liver biopsy are outlined in Table 9.1.7. Subjects may be asked to provide a liver biopsy during Year 1, at or around Week 52, and during the Years 2-5 period post-BMN 270 infusion.</u></p> <p><u>Subjects consenting to participate to the optional liver biopsy will undergo pre-biopsy assessments at least 28 days before the procedure, as follows:</u></p> <ul style="list-style-type: none"> <li>• <u>Liver ultrasound (subject should fast at least 8 hours prior to ultrasound)</u></li> <li>• <u>Physical examination</u></li> <li>• <u>Hematology, coagulation, chemistry assessments</u></li> </ul>  | <p>10</p>        |



| Section No./Title             | Revision  | Rationale |
|-------------------------------|---|-----------|
|                               | <ul style="list-style-type: none"> <li>• <u>Liver tests</u></li> <li>• <u>FibroScan</u></li> </ul> <p><u>Subjects consenting to participate to the optional liver biopsy will undergo pre-biopsy assessments at least 7 days before the procedure, as follows:</u></p> <ul style="list-style-type: none"> <li>• <u>FVIII activity level assessment (central and local)</u></li> <li>• <u>Exploratory CK18 and Grp78 assessment</u></li> <li>• <u>Pre-biopsy consultation (with hepatologist and/or radiologist)</u></li> </ul> <p><u>On the day of the biopsy, brief physical examination and liver and blood tests should be performed before the procedure (including hematology, coagulation, and chemistry). FVIII activity assessment should also be performed to ensure the subject has sufficient FVIII activity to protect against procedure-related bleeding (as discussed above). LT assessment and a whole blood draw for PBMC collection should be performed on the biopsy day or ± 1 week from the biopsy day.</u></p> <p><u>The optional liver biopsy should be performed in the morning if feasible, and the biopsy procedure and follow-up care should be done according to the local standard of care. Additional details for handling the biopsy specimens are provided in the Laboratory Manual.</u></p> <p><u>Following completion of the biopsy, the subject should remain under observation in the clinic for at least 4-6 hours. Overnight post-procedure observation may be done at the investigator's discretion and/or according to local guidelines.</u></p> |           |
| Section 14.1/Interim Analyses | <p><del>An</del><u>Two interim analysis is</u>analyses were planned, after approximately <u>16 and 20</u> treated HIV-negative subjects <del>have, respectively,</del> completed the Week 26 visit (or have discontinued study participation prior to Week 26). <del>Data will be reviewed by the DMC. The first interim analysis was performed as planned in May 2019. Based on the SAP, and a formal recommendation will be made</del><u>interim results and the totality of the data, the secondary interim analysis was deemed unnecessary. The DMC reviewed the interim analysis results to assess the efficacy and safety profiles, whether to continue the study as designed, the pre-specified criteria of statistical significance has been achieved, and the risk/benefit ratio of the interventions in the BMN 270 studies based on the totality of the data.</u></p> <p>The primary efficacy endpoint for the interim <del>analysis</del><u>analyses</u> involves hFVIII activity, as measured by chromogenic substrate assay, achieved post-BMN 270 infusion.</p> <p>The fallback procedure (Wiens, 2005) will be used to adjust for multiplicity <del>of the two interim analysis</del><u>analyses</u> at Week 26 and the final analysis at Week 52 (regardless of the interim <del>analysis</del><u>analyses</u> results, the study is planned to continue upon the DMC's</p>  | 1         |



| Section No./Title                                  | Revision   | Rationale |
|--|--|-----------|
|  | <p>recommendation, and the final analysis will be performed at Week 52). At the final analysis at Week 52, the secondary efficacy endpoints will be tested hierarchically; the level of significance will be determined by the fallback procedure.</p> <p>The secondary and tertiary endpoints will be summarized descriptively at the interim (Week 26) <del>analysis</del> <u>analyses</u>.</p> <p>The details of the interim <del>analysis</del> <u>analyses</u>, including the control of Type I error rate, will be specified in the SAP.</p>   |           |
| Section 14.3/ Secondary Efficacy Endpoints         | <p>A sensitivity analysis is planned to analyze ABR using a generalized linear mixed model assuming negative binomial as the underlying distribution. The model will include period (pre- to post-BMN 270 infusion) as the only factor. The actual number of bleeding episodes will be used as the <del>independent</del> <u>dependent</u> variable with the time period adjustment (<del>annualization</del> <u>annualization</u>) being implemented as the offset.</p>   | 22        |
| Section 14.4/Liver Biopsy Substudy Analysis        | <p><u>A separate report presenting and discussing analyses of the exploratory objectives for the optional liver biopsy substudy will be prepared.</u></p>  | 10        |
| Section 16/Costs, Compensation, and Subject Injury | <p><del>There will be no charge to study subjects to be in this study. BioMarin will pay the full costs of the study-related tests, procedures, and treatments set forth in this protocol that are part of this study.</del> In addition, after IRB/IEC/REB approval, BioMarin may reimburse the reasonable cost of travel for study-related visits in accordance with BioMarin’s travel and reimbursement policy. <del>BioMarin will not pay for any hospitalizations, tests, or treatments for medical problems of any sort related solely to the study subject’s disease. Costs associated with such hospitalizations, tests, and treatments should be billed and collected in the way that such costs are usually billed and collected outside the study.</del></p> <p>The Investigator should contact BioMarin immediately upon notification that a study subject has been injured by the study drug or by procedures performed as part of the study. Any subject who experiences a study-related injury should be instructed by the Investigator to seek immediate medical treatment at a pre-specified medical institution if possible, or at the closest medical treatment facility if necessary. The subject should be given the name of a person to contact to seek further information about, and assistance with, treatment for study-related injuries. <del>The treating physician should bill the subject’s health insurance company or other third party payer for the cost of this medical treatment. If the cost of the medical treatment is not covered by health insurance or another third party that usually pays these costs, then either BioMarin or the institution may pay for reasonable and necessary medical services to treat the injuries caused by the study drug or study procedures. In some jurisdictions, BioMarin is obligated by law to pay for study-related injuries without prior recourse to third party payer billing and/or regardless of fault.</del> If this is the case, BioMarin will comply with the law. <u>BioMarin will not pay for any hospitalizations, tests, or treatments for medical problems of any sort related solely to the study subject’s primary disease or any concurrent disease and that are unrelated to this study.</u></p> | 21        |



| Section No./Title     | Revision  | Rationale |
|-----------------------|---|-----------|
| Section 21/References | <p data-bbox="474 354 1713 443"><u>Grant A, Neuberger J, Day C, Saxseena S. British Society of Gastroenterology Guidelines on the use of Liver Biopsy in Clinical Practice. 2004. Available at: <a href="https://www.bsg.org.uk/resource/bsg-guidelines-on-the-use-of-liver-biopsy-in-clinical-practice.html">https://www.bsg.org.uk/resource/bsg-guidelines-on-the-use-of-liver-biopsy-in-clinical-practice.html</a> (last visited 20 January 2020).</u></p> <p data-bbox="474 467 1682 524"><u>National Center for Biotechnology Information (NCBI). LiverTox: Clinical and Research Information on Drug-Induced Liver Injury. Available at: <a href="https://livertox.nih.gov">https://livertox.nih.gov</a> (last accessed 14 January 2020).</u></p> | 22        |



## CLINICAL STUDY PROTOCOL (UNITED STATES-SPECIFIC)

**Study Title:** A Phase 3 Open-Label, Single-Arm Study To Evaluate The Efficacy and Safety of BMN 270, an Adeno-Associated Virus Vector–Mediated Gene Transfer of Human Factor VIII in Hemophilia A Patients with Residual **FVIII Levels  $\leq$  1 IU/dL Receiving Prophylactic FVIII Infusions**

**Protocol Number:** 270-301

**Active Investigational Product:** AAV5-hFVIII-SQ

**IND/European Union Drug Regulating Authorities Clinical Trials (EudraCT) Number:** **2017-003215-19**  
**IND #: 017659**

**Indication:** Hemophilia A

**Sponsor:** BioMarin Pharmaceutical Inc.  
**105 Digital Drive**  
**Novato, CA 94949**

**Development Phase:** Phase 3

**Sponsor's Responsible Medical Monitor:** PI [REDACTED], MD, PhD  
PI [REDACTED]  
BioMarin Pharmaceutical Inc.  
**105 Digital Drive Novato, CA 94949**

**Duration of Subject Participation:** **Approximately 264 weeks**

**Dose:** **6E13 vg/kg**

**Study Population:** **Males aged 18 or older**

**Date of Original Protocol:** **14 August 2017**

**Date of Amendment 1 (United States Specific):** **2 October 2017**

**Date of Amendment 1 (Global)** **25 January 2018**

**Date of Amendment 2 (Global)** **28 June 2018**

**Date of Amendment 3 (Global)** **24 August 2018**

**Date of Amendment 4 (Global)** **9 November 2018**

**Date of Amendment 5 (Global)** **10 May 2019 (unreleased)**

**Date of Amendment 6 (Global)** **3 April 2020**

**Date of Amendment 7 (Global)** **14 July 2021**

**Date of Amendment 7 (US)** **15 July 2021**

Property of BioMarin  
**CONFIDENTIAL**

May not be divulged, published, or otherwise disclosed to others without prior written approval from BioMarin.

**This study will be conducted according to the principles of Good Clinical Practice as described in the U.S. Code of Federal Regulations and the International Conference on Harmonisation Guidelines, including the archiving of essential documents**



**CLINICAL STUDY PROTOCOL AMENDMENT SUMMARY****Amendment 7 (United States-Specific)****Date: 15 July 2021**

---

**RATIONALE AND SUMMARY OF CHANGES**

A summary of major changes covered by Amendment 7 to the 270-301 protocol is provided below.

1. **Changes have been made to enhance screening for potential malignancies (including hepatic cancers) after dosing with BMN 270.**

**Rationale:** The changes made include:

- Including a targeted liver ultrasound at the End of Year visits for Year 2 through Year 5 to screen for HCC (additional interim liver ultrasounds may be performed at the discretion of the Investigator);
- Recommending genomic analyses for any malignancy (except non-melanoma skin cancer) diagnosed during the course of the study.

**Year-end liver ultrasounds are being implemented to assess the theoretical risk of HCC.**

While no cases of HCC have been reported in the Sponsor's AAV gene therapy non-clinical or clinical trials (more than 150 patients dosed, with some dosed more than 5 years ago), these assessments will further inform this theoretical risk.

2. **Malignancy (except non-melanoma skin cancer) has been added as an Event of Special Interest (EOSI).**

**Rationale:** The occurrence of malignancy (as above) was added as an EOSI for purposes of expedited safety reporting and additional safety monitoring.

3. Language around the statistical analysis of secondary endpoints and objective has been amended.

**Rationale:** The efficacy evaluation period for analysis of the secondary endpoints (annualized bleeding rate and exogenous FVIII usage) has been changed to examine the period from Week 5 to the last visit at the time of any data cutoff (as opposed to the original language, which was from Week 5-Week 52). This change reflects the plan to extend the timeframe of the study and allow for the possibility of producing one or more interim CSRs that may have data cutoffs after Week 52 but before the end of the study (Week 260).

4. Language has been added concerning the use of the SARS-CoV-2 vaccines.

**Rationale:** Due to the current worldwide SARS-CoV-2 pandemic and evolving availability and types of vaccines, language has been added to assist with timing and planning for **vaccine administration. The Sponsor's recommendations reflect the risk** assessment conducted on the currently available vaccines and guidance from multiple health agencies, and include information regarding different types of SARS-CoV-2 vaccines.

5. The reactive corticosteroid regimen for ALT elevation has been updated.

**Rationale:** The guidance for the reactive corticosteroid regimen, including management of ALT elevations and corticosteroid taper, reflects the data gathered from previous BMN 270 studies. This change attempts to promote the safe and effective use of reactive corticosteroids.

6. **Thrombin generation assay (TGA) assessment has been removed.**

**Rationale:** Assessment of TGA to date in the BMN 270 development program has provided **sufficient data; additional assessments are not expected to be needed. Removing this** assessment helps to alleviate patient and site burden. If TGA assessments from 270-301 **are needed in the future, backup aliquots from other platelet-poor plasma samples** may be utilized.

7. The definition of treatment failure has been changed.

**Rationale:** The previous definition **required either a failure to achieve FVIII activity  $\geq 5$  IU/dL by Week 52 or an inability to maintain independence from prophylactic FVIII replacement therapy due to joint bleeding episodes; the revised definition requires both of** these conditions to be present before a subject may be considered a treatment failure. The revision reflects the data seen as of the **52-week data cut for 270-301, where some subjects were still able to remain off of prophylactic FVIII replacement therapy (due to an absence of treated bleeding events) despite lower FVIII levels 1 or more years after BMN 270 infusion.**

8. **Frequency of several laboratory assessments during Years 2-5** has been decreased. These changes include:

- **Reducing FVIII Antigen BDD Assay to Q12W for Years 2-5**

**Rationale:** **Robust characterization is already available from Year 1 data, and more frequent sampling is not needed to understand long-term protein to activity ratios**

- **Reducing AAV5 TAb to End of Year Visits only for Years 3-5**

**Rationale:** Antibody response is high and does not change much over time. Yearly testing should be sufficient to understand longer term responses, as little change is expected.

- Reducing FVIII TAb to End of Year Visits only for Years 3-5  
**Rationale:** FVIII Bethesda Inhibitor is the main safety assessment. After 3 years, if **there is a need in specific instances for data more frequent than once a year, backup plasma from another assay may be used for testing.**
- **Reducing AAV5 TI assay to End of Year 5 Visit only (or at the Early Termination Visit, as applicable)**

**Rationale:** The most significant information from this assessment is obtained from baseline and samples collected shortly after dosing. As the TI remains high after dosing, **there is no need to continue to track frequently beyond a year after infusion.**

9. Additional changes to the statistical analysis language have been made, including a new protocol appendix that outlines changes made specifically for analyses to be submitted in **the United States.**

**Rationale:** The changes were made in **alignment with the FDA's request to revise this protocol and the statistical analysis plan (SAP) to specify annualized bleeding rate (ABR) as the primary endpoint, with the primary efficacy assessment based on results through two years post-BMN 270 infusion follow-up for all subjects.**

10. Additional details on obtaining multiple biopsies as part of the liver biopsy substudy have been added.
11. The identity of the medical monitor has been updated.
12. Minor changes have been made for purposes of consistency and clarity.

Refer to Section [26](#) for a summary of revisions to Amendment 6 (dated 3 April 2020).

## 2 SYNOPSIS

|  |   |  |
|--|---|--|
| <p><b>NAME OF COMPANY</b><br/>BioMarin Pharmaceutical Inc.<br/><b>105 Digital Drive</b><br/><b>Novato, CA 94949</b></p> <p><b>NAME OF FINISHED PRODUCT:</b><br/>BMN 270</p> <p><b>NAME OF ACTIVE INGREDIENT:</b><br/>AAV5-hFVIII-SQ</p>  | <p><b>SUMMARY TABLE</b><br/>Referring to Part of the Dossier:</p> <p>Volume:</p> <p>Page:</p> <p>Reference:</p> | <p><b>FOR NATIONAL AUTHORITY USE ONLY:</b></p> |
| <p><b>TITLE OF STUDY:</b><br/>A Phase 3 Open-Label, Single-Arm Study To Evaluate The Efficacy and Safety of BMN 270, an Adeno-Associated Virus Vector-Mediated Gene Transfer of Human Factor VIII in Hemophilia A <b>Patients with Residual FVIII Levels <math>\leq</math> 1 IU/dL Receiving Prophylactic FVIII Infusions</b></p>  |   |  |
| <p><b>PROTOCOL NUMBER:</b><br/>270-301</p>   |   |  |
| <p><b>STUDY SITES:</b><br/><b>Approximately 60 sites worldwide.</b></p>  |   |  |
| <p><b>PHASE OF DEVELOPMENT:</b><br/>Phase 3</p>  |   |  |
| <p><b>STUDY RATIONALE:</b><br/><b>Hemophilia A (HA) is an X-linked recessive bleeding disorder that affects approximately 1 in 5,000 males. It is caused by deficiency in the activity of coagulation factor VIII (FVIII), an essential cofactor in the intrinsic coagulation pathway. This disorder can be either inherited, due to a genetic aberrancy, or an acquired immunologic process, leading to insufficient quantities of FVIII or a dysfunctional FVIII, but all are characterized by a defective coagulation process. The clinical phenotype of HA patients generally correlates tightly with the level of residual expression. Severe HA is classified as FVIII activity less than 1% of wild-type (&lt; 1 IU/dL), moderate disease comprises 1-5% of wild-type activity and the mild form is 5-40% activity. The clinical manifestations of severe HA are frequent spontaneous bleeding episodes, predominantly in joints and soft tissues, with a substantially increased risk of death from hemorrhage when the brain is involved. Subjects with moderate disease can exhibit manifestations similar to those seen in patients with severe HA, resulting in a comparable bleeding phenotype. Treatment of severe HA presently consists of intravenous injection of plasma-derived or recombinant human FVIII protein (rhFVIII) concentrates, both as prophylaxis 2-3 times per week, and at the time of a bleed, to prevent or control bleeding episodes, respectively. The half-life for FVIII (12 to 18 hours for most approved products) necessitates frequent infusions, and although a major advance in the treatment of HA, it remains common for severe HA patients to continue to have multiple bleeding events on prophylactic therapy (median annualized bleeding rate [ABR] of 1-4 with prophylaxis treatment in a recently published retrospective observational study and between 1-2 in 6 prospective FVIII interventional studies) and on-demand-only therapy (median ABR of 4.5-18 in a recently published retrospective study and between 20-60 in 6 prospective FVIII interventional studies). The consequence of multiple bleeding events is the development of</b></p> |   |  |

| NAME OF COMPANY<br>BioMarin Pharmaceutical Inc.<br><b>105 Digital Drive</b><br><b>Novato, CA 94949</b>  | SUMMARY TABLE<br>Referring to Part of the<br>Dossier:<br><br>Volume:<br><br>Page:<br><br>Reference: | FOR NATIONAL<br>AUTHORITY USE<br>ONLY: |
|---|---|--|
| <p><b>NAME OF FINISHED PRODUCT:</b><br/>BMN 270</p> <p><b>NAME OF ACTIVE INGREDIENT:</b><br/>AAV5-hFVIII-SQ</p> <p>debilitating multiple-joint arthropathy and substantially increased risk of death. Chemical <b>modification (eg, direct conjugation of polyethylene glycol (PEG) polymers) and bioengineering of FVIII (eg, FVIII-Fc fusion proteins) improve half-life by approximately 50%, and thus, show promise in reduced dosing and maintaining activity levels above a 1% trough for a greater proportion of the dosing interval.</b> However, patients with severe HA who are treated with extended half-life FVIII remain dependent on multiple infusions to maintain critical levels of FVIII activity. There is therefore a strong unmet need for a fully preventive treatment of HA to give patients a FVIII level compatible with a normal and hemorrhage-free life.</p> <p>Gene therapy offers the potential of disease-modifying therapy by continuous endogenous production of active FVIII following a single intravenous infusion of a vector encoding the <b>appropriate gene sequence for long-term episomal expression.</b> Hemophilia A is well-suited for a <b>gene replacement approach because clinical manifestations are attributable to the lack of a single gene product (FVIII) that circulates in minute amounts (200 ng/ml) in the plasma. Tightly regulated control of gene expression is not essential, and even modest increases in the level of FVIII (any increase of the plasma level by 2 ng/ml induces an increase in activity of 1%) can ameliorate the severe form of hemophilia A.</b> Thus, relatively small changes in endogenous FVIII activity can result in clinically relevant improvements in disease phenotype. Finally, the circulating FVIII response to gene <b>transduction can be assessed using validated quantitative rather than qualitative endpoints that are easily assayed using established laboratory techniques.</b></p> <p>Several different gene transfer strategies for FVIII replacement have been evaluated, but adeno-associated viral (AAV) vectors show the greatest promise. <b>They have an excellent and well-defined safety profile, and can direct long-term transgene expression with tropism and promoter specificity for specific tissues, such as the liver (for serotypes 2, 5 and 8 among others).</b> Indeed, an ongoing gene therapy clinical trial for a related disorder, hemophilia B, has established <b>that stable (median follow-up of 3.2 years) expression of human factor IX (hFIX) at levels that are sufficient for conversion of their bleeding phenotype from severe to moderate or mild is achievable following a single peripheral vein infusion of AAV8-hFIX vector. Several participants in this trial have been able to discontinue factor prophylaxis without suffering spontaneous hemorrhages, even when they undertook activities that previously resulted in bleeding. Thus, gene therapy treatment has resulted in a substantial improvement in their quality of life.</b></p> <p>BMN 270 is an AAV5-based gene therapy vector that expresses the SQ form of hFVIII under the control of a hybrid human liver-specific promoter (Figure 1).</p> |   |  |

|   |  |   |
|---|--|---|
| <b>NAME OF COMPANY</b><br>BioMarin Pharmaceutical Inc.<br>105 Digital Drive<br>Novato, CA 94949<br><br><b>NAME OF FINISHED PRODUCT:</b><br>BMN 270<br><br><b>NAME OF ACTIVE INGREDIENT:</b><br>AAV5-hFVIII-SQ | <b>SUMMARY TABLE</b><br>Referring to Part of the<br>Dossier:<br><br>Volume:<br><br>Page:<br><br>Reference: | <b>FOR NATIONAL<br/>         AUTHORITY USE<br/>         ONLY:</b> |
|---|--|---|

**Figure 1: hFVIII-SQ Vector Genome and Encoded Protein**

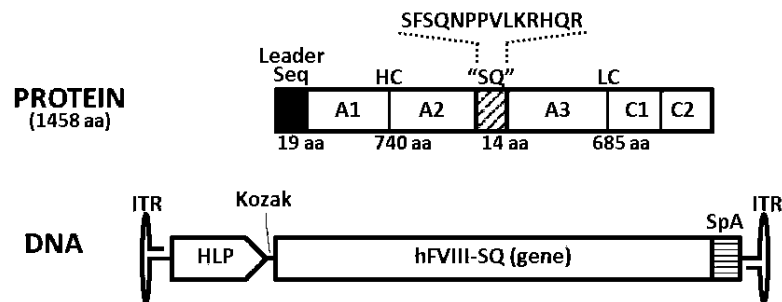

Legend –Note that schematic is not to scale; aa = amino acids; ITR = inverted terminal repeat; HLP = human liver promoter; Kozak = Kozak consensus sequence (GCCACC); SpA = Synthetic poly(A) signal

BMN 270 will be delivered by a single intravenous dose and is designed to achieve stable, potentially life-long expression of active hFVIII in the plasma, synthesized from vector-transduced liver tissue.

BMN 270 is being evaluated in clinical study 270-201, **an ongoing first-in-human, phase 1/2 dose escalation study** in subjects with severe HA designed to assess the safety and efficacy of BMN 270 **at various dose levels (6E12 vg/kg, 2E13 vg/kg, 4E13 vg/kg, 6E13 vg/kg). Specifically, 270-201** explores the relationship of vector dose to the augmentation of residual FVIII activity and whether these levels are sufficient to alter the clinical phenotype. Four-year results from 270-201 **and one-year results from 270-301 have demonstrated that following gene transfer, mean and median FVIII activity levels above 15% (15 IU/dL)**, as measured by a chromogenic substrate assay, are **achievable and sustained following a single infusion of 6E13 vg/kg of BMN 270, with an acceptable safety profile.** Preliminary results from optional liver biopsies confirm dose-dependent pan-lobular and otherwise healthy liver transduction at **2.7-4.1 years.**

The current study is a Phase 3, single-arm, open-label study designed to assess whether, in an expanded sample, BMN 270 can safely alter the clinical phenotype of hemophilia A patients with residual FVIII activity  $\leq 1$  IU/dL.

**OBJECTIVES:**

The primary efficacy objective of the study is to:

- Assess the efficacy of BMN 270 defined as FVIII activity, as measured by chromogenic substrate assay, during Weeks 49-52 following intravenous infusion of BMN 270



|  |   |  |
|--|---|--|
| <p><b>NAME OF COMPANY</b><br/>BioMarin Pharmaceutical Inc.<br/><b>105 Digital Drive</b><br/><b>Novato, CA 94949</b></p> <p><b>NAME OF FINISHED PRODUCT:</b><br/>BMN 270</p> <p><b>NAME OF ACTIVE INGREDIENT:</b><br/>AAV5-hFVIII-SQ</p>  | <p><b>SUMMARY TABLE</b><br/>Referring to Part of the<br/>Dossier:</p> <p>Volume:</p> <p>Page:</p> <p>Reference:</p> | <p><b>FOR NATIONAL<br/>AUTHORITY USE<br/>ONLY:</b></p> |
| <p>The secondary efficacy objectives of the study are to:</p> <ul style="list-style-type: none"> <li>Assess the impact of BMN 270 on usage of exogenous FVIII replacement therapy in the <b>efficacy evaluation period (from Week 5 to last visit by the data cutoff for the 1-year analysis, hereafter referred to as “Week 5 to Last Visit”)</b></li> <li><b>Assess the impact of BMN 270 on the number of bleeding episodes requiring exogenous FVIII replacement therapy in the efficacy evaluation period (“Week 5 to Last Visit”)</b></li> </ul> <p>The tertiary efficacy objective of the study is to:</p> <ul style="list-style-type: none"> <li>Assess the impact of BMN 270 on <b>patient-reported outcomes (PROs) at Week 52</b> of the study compared to baseline</li> </ul> <p>The safety objectives of the study are to:</p> <ul style="list-style-type: none"> <li><b>Evaluate the safety of BMN 270 during the first 52 weeks following intravenous infusion</b></li> <li>Assess the long-term safety of BMN 270</li> </ul> <p>The exploratory objectives of the liver biopsy substudy are:</p> <ul style="list-style-type: none"> <li>To examine the histopathology of the liver following BMN 270 therapy, including <b>assessing for possible safety findings (eg, fibrosis, fatty liver disease, lymphocytic invasion)</b></li> <li><b>To quantify FVIII DNA, RNA, and protein expression within hepatocytes</b></li> <li>To determine which forms of rAAV vector DNA are present at the time of biopsy.</li> <li><b>To determine the transduction pattern of BMN 270 in humans (ie, peri-portal hepatocytes, central vein hepatocytes)</b></li> </ul> <p>The aforementioned study efficacy objectives were achieved through the pre-specified analysis at <b>Week 52 (“1 year analysis”) for the study, which was performed in January 2021 after all subjects had been followed for 52 weeks post-BMN 270 infusion (data cutoff date: 16 November 2020).</b> Results from this analysis are intended to support regulatory submissions to EMA and other health authorities outside of FDA.</p> <p><b>The FDA has requested BioMarin to submit 2-year safety and efficacy data on all subjects in 270-301 to enable their benefit risk assessment of BMN 270. To fulfill this regulatory requirement, Appendix 2 has been created to specify region-specific study objectives for the United States and the associated endpoints and analyses to achieve them. This analysis (“2-year analysis”) will be performed after all subjects have completed the Week 104 visit or have withdrawn from the study.</b></p> |   |  |

|   |   |  |
|---|---|--|
| <p><b>NAME OF COMPANY</b><br/>BioMarin Pharmaceutical Inc.<br/><b>105 Digital Drive</b><br/><b>Novato, CA 94949</b></p> <p><b>NAME OF FINISHED PRODUCT:</b><br/>BMN 270</p> <p><b>NAME OF ACTIVE INGREDIENT:</b><br/>AAV5-hFVIII-SQ</p> | <p><b>SUMMARY TABLE</b><br/>Referring to Part of the Dossier:</p> <p>Volume:</p> <p>Page:</p> <p>Reference:</p> | <p><b>FOR NATIONAL AUTHORITY USE ONLY:</b></p> |
|---|---|--|

**STUDY DESIGN AND PLAN:**

This is a Phase 3, single-arm, open-label study in hemophilia A patients with residual FVIII levels  $\leq 1$  IU/dL treated continuously with prophylactic exogenous FVIII for a minimum of one year prior to enrollment. **Subjects will be enrolled at approximately 60 sites worldwide. Subjects must have high-quality, well-documented historical data available concerning previous bleeding episodes and exogenous FVIII usage over the previous 12 months in order to be eligible to enroll in the study.**

**Approximately 130 adult subjects with severe HA will receive a 6E13 vg/kg dose of BMN 270 as a single intravenous infusion. Approximately 20 subjects will enroll in the study with at least 12 months of well-documented high-quality historical data concerning previous bleeding episodes and exogenous FVIII usage, while approximately 110 subjects will enroll in the study after having completed approximately 6 months' participation in the BioMarin-sponsored non-interventional study 270-902, in which bleeding and FVIII use data prior to gene therapy will be prospectively collected.**

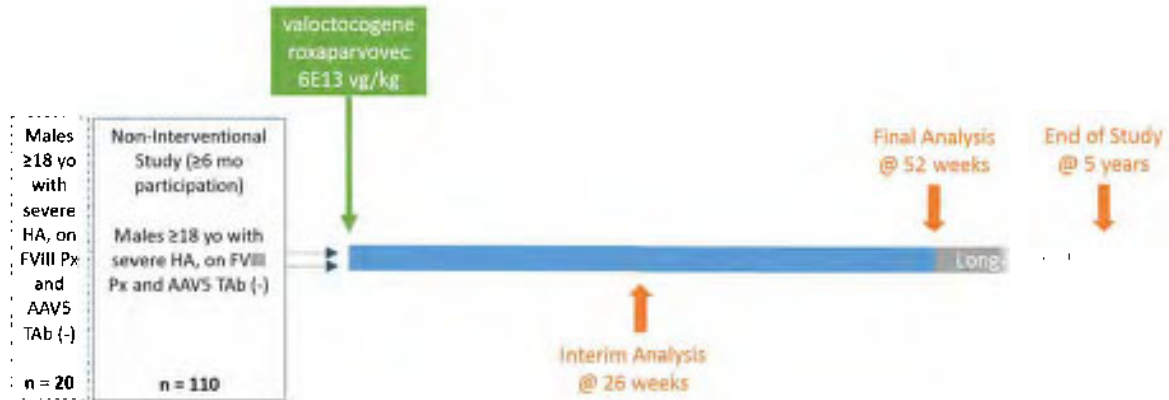

yo = years old, HA = hemophilia A, FVIII = factor VIII, Px = prophylaxis, AAV5 = adeno-associated virus, serotype 5, TAB = total antibody, mo = month, vg = vector genomes, kg = kilogram, f/u = follow-up



| NAME OF COMPANY<br>BioMarin Pharmaceutical Inc.<br><b>105 Digital Drive</b><br><b>Novato, CA 94949</b><br><br>NAME OF FINISHED PRODUCT:<br>BMN 270<br><br>NAME OF ACTIVE INGREDIENT:<br>AAV5-hFVIII-SQ   | SUMMARY TABLE<br>Referring to Part of the<br>Dossier:<br><br>Volume:<br><br>Page:<br><br>Reference: | FOR NATIONAL<br>AUTHORITY USE<br>ONLY: |
|--|---|--|
| <p>In order to minimize bias in the ongoing study and to assure safe and ethical conduct of the clinical trial, an independent Data Monitoring Committee (DMC), consisting of experts in clinical trials, statistics, and hemophilia, has been convened. The DMC will have sole access during the trial to amalgamated FVIII activity levels, FVIII usage, and bleeding data and review available safety and efficacy (eg, FVIII activity) data during the study on an ongoing basis; they may determine, based on emerging data and the risk/benefit profile, that further enrollment at 6E13 vg/kg should be discontinued in favor of a different dose of BMN 270, not to exceed 6E13 vg/kg. If the DMC recommends a dosing modification, then additional subjects may be enrolled, up to a total of approximately 130 subjects, at the new BMN 270 dose level (regardless of the number of subjects previously enrolled at 6E13 vg/kg).</p> <p>Two interim analyses were planned, after the first approximately 16 and 20 treated HIV-negative subjects, respectively, completed the Week 26 visit (or have discontinued study participation prior to Week 26). The first interim analysis was performed as planned in May 2019. Based on the interim results and the totality of the data, the secondary interim analysis was deemed unnecessary. The DMC reviewed interim analysis results to assess the efficacy and safety profiles, whether the pre-specified criteria of statistical significance has been achieved, and the risk/benefit ratio of the interventions in the BMN 270 studies based on the totality of the data.</p> <p>The 1-year analysis for the study was performed after all subjects had been followed for 52 weeks post-BMN 270 infusion. A separate 2-year analysis will also be performed per request from the FDA after all subjects have been followed for 104 weeks post-BMN 270 infusion. After the 1-year and the 2-year analyses, safety and efficacy will then continue to be assessed long-term in all subjects for a total of approximately 5 years.</p> <p>To avoid breakthrough bleeding, subjects will only discontinue exogenous prophylactic FVIII replacement therapy 4 weeks following infusion of BMN 270. Four weeks represents the time by which endogenous production of FVIII following gene transfer is expected to be efficacious, based on earlier results.</p> <p>In subjects who experience recurring bleeding episodes, the Investigator and Medical Monitor will discuss whether to resume prior FVIII prophylaxis.</p> <p>Subjects who do not respond to BMN 270 treatment (ie, treatment failure, manifesting as failure to achieve FVIII activity <math>\geq 5</math> IU/dL by Week 52 and inability to maintain independence from prophylactic FVIII replacement therapy due to joint bleeding episodes, in the judgment of the Investigator) may, at the Investigator's discretion and after discussion with the Medical Monitor or Sponsor-designated Data Monitor, follow an abbreviated visit schedule after Week 52 of the study by attending only the Q12W and End of Year visits during Years 2-5. Subjects who are not attending the Q4W/Q6W visits during Years 2-5 may receive a scheduled monthly follow-up telephone call from the site to ask about adverse events, concomitant medications, and bleeding events/FVIII replacement usage.</p> |   |  |

|   |   |  |
|---|---|--|
| <p><b>NAME OF COMPANY</b><br/>BioMarin Pharmaceutical Inc.<br/><b>105 Digital Drive</b><br/><b>Novato, CA 94949</b></p> <p><b>NAME OF FINISHED PRODUCT:</b><br/>BMN 270</p> <p><b>NAME OF ACTIVE INGREDIENT:</b><br/>AAV5-hFVIII-SQ</p>   | <p><b>SUMMARY TABLE</b><br/>Referring to Part of the<br/>Dossier:</p> <p>Volume:</p> <p>Page:</p> <p>Reference:</p> | <p><b>FOR NATIONAL<br/>AUTHORITY USE<br/>ONLY:</b></p> |
| <p>There will be an ongoing review of individual subject safety by the Medical Monitor, and both safety and efficacy data by the DMC. Therapeutic oral corticosteroids or other systemic immunosuppressive agents may be initiated when a subject's ALT values are elevated, and <b>subsequent dosage adjustments made, after consultation between the Investigator and the Medical Monitor.</b></p> <p>Any safety signal may trigger a review of the data and possible additional immunogenicity studies or other diagnostics deemed necessary that include an assessment of cellular immune responses using collected peripheral blood mononuclear cells (<b>PBMCs</b>).</p> <p><b>An optional liver biopsy will be performed as part of the liver biopsy substudy (in subjects who consent to do so) during Year 1 post-infusion, at or around Week 52, and/or during Years 2-5 following BMN 270 infusion. Subjects who consent to the liver biopsy will have additional assessments including a liver ultrasound and FibroScan, and will receive prophylactic FVIII prior to the procedure if indicated in the judgment of the Investigator, to minimize the risk of bleeding. Additional liver biopsies may be performed as part of the substudy during Years 2-5 as clinically indicated.</b></p>  |   |  |
| <p><b>NUMBER OF SUBJECTS PLANNED:</b><br/><b>Approximately 130 subjects may enroll into the study.</b></p>  |   |  |
| <p><b>DIAGNOSIS AND ALL CRITERIA FOR INCLUSION AND EXCLUSION:</b><br/>Patients are eligible to be included in the study only if all of the following criteria apply:</p> <ol style="list-style-type: none"> <li><b>1. Males <math>\geq</math> 18 years of age with hemophilia A and residual FVIII levels <math>\leq</math> 1 IU/dL as evidenced by medical history, at the time of signing the informed consent.</b></li> <li><b>2. Must have been on prophylactic FVIII replacement therapy for at least 12 months prior to study entry. High-quality, well-documented historical data concerning bleeding episodes and FVIII usage over the previous 12 months must be available.</b></li> <li><b>3. Treated/exposed to FVIII concentrates or cryoprecipitate for a minimum of 150 exposure days (EDs).</b></li> <li><b>4. Willing and able to provide written, signed informed consent after the nature of the study has been explained and prior to any study-related procedures.</b></li> <li><b>5. No previous documented history of a detectable FVIII inhibitor, and results from a Bethesda assay or Bethesda assay with Nijmegen modification of less than 0.6 Bethesda Units (BU) (or less than 1.0 BU for laboratories with a historical lower sensitivity cutoff for inhibitor detection of 1.0 BU) on 2 consecutive occasions at least one week apart within the past 12 months (at least one of which should be tested at the central laboratory).</b></li> </ol> |   |  |

| <b>NAME OF COMPANY</b><br>BioMarin Pharmaceutical Inc.<br><b>105 Digital Drive</b><br><b>Novato, CA 94949</b><br><br><b>NAME OF FINISHED PRODUCT:</b><br>BMN 270<br><br><b>NAME OF ACTIVE INGREDIENT:</b><br>AAV5-hFVIII-SQ   | <b>SUMMARY TABLE</b><br>Referring to Part of the<br>Dossier:<br><br>Volume:<br><br>Page:<br><br>Reference: | <b>FOR NATIONAL<br/>           AUTHORITY USE<br/>           ONLY:</b> |
|---|--|---|
| <p><b>6.</b> Sexually active participants must agree to use an acceptable method of effective contraception, either double-<b>barrier contraception (ie, condom + diaphragm; or condom or diaphragm + spermicidal gel or foam) or their female partner either using hormonal</b> contraceptives or having an intrauterine device. Participants must agree to <b>contraception use for at least 12 weeks post-infusion; after 12 weeks, subjects may stop contraception</b> use only if they have had 3 consecutive semen samples with viral vector DNA below the limit of detection.</p> <p><b>7.</b> Willing to abstain from alcohol consumption for at least the first <b>52 weeks following</b> BMN 270 infusion.</p> <p>Patients are excluded from the study if any of the following criteria apply:</p> <ol style="list-style-type: none"> <li><b>1.</b> Detectable pre-existing antibodies to the AAV5 capsid.</li> <li><b>2.</b> Any evidence of active infection or any immunosuppressive disorder, including HIV infection.</li> <li><b>3.</b> Significant liver dysfunction with any of the following abnormal laboratory results:           <ul style="list-style-type: none"> <li>• <b>ALT (alanine aminotransferase) &gt; 1.25x ULN;</b></li> <li>• <b>AST (aspartate aminotransferase) &gt; 1.25x ULN;</b></li> <li>• <b>GGT (gamma-glutamyltransferase) &gt; 1.25x ULN;</b></li> <li>• <b>Total bilirubin &gt; 1.25x ULN;</b></li> <li>• <b>Alkaline phosphatase &gt; 1.25x ULN; or</b></li> <li>• <b>INR (international normalized ratio) ≥ 1.4.</b></li> </ul> </li> </ol> <p>Subjects whose liver laboratory assessments fall outside of these ranges may undergo repeat testing of the entire liver test panel within the same Screening window and, if eligibility criteria are met on retest, may be enrolled after confirmation by the Medical Monitor.</p> <ol style="list-style-type: none"> <li><b>4. Prior liver biopsy showing significant fibrosis of 3 or 4 as rated on a scale of 0-4 on the Batts-Ludwig or METAVIR scoring systems, or an equivalent grade of fibrosis if an alternative scale is used.</b></li> <li><b>5.</b> Evidence of any bleeding disorder not related to hemophilia A.</li> <li><b>6. Platelet count of &lt; 100 x 10<sup>9</sup>/L.</b></li> <li><b>7. Creatinine ≥ 1.5 mg/dL.</b></li> </ol> |  |   |

| <p><b>NAME OF COMPANY</b><br/>BioMarin Pharmaceutical Inc.<br/><b>105 Digital Drive</b><br/><b>Novato, CA 94949</b></p> <p><b>NAME OF FINISHED PRODUCT:</b><br/>BMN 270</p> <p><b>NAME OF ACTIVE INGREDIENT:</b><br/>AAV5-hFVIII-SQ</p>  | <p><b>SUMMARY TABLE</b><br/>Referring to Part of the<br/>Dossier:</p> <p>Volume:</p> <p>Page:</p> <p>Reference:</p> | <p><b>FOR NATIONAL<br/>AUTHORITY USE<br/>ONLY:</b></p> |
|--|---|--|
| <p><b>8.</b> Liver cirrhosis of any etiology as assessed by liver ultrasound.</p> <p><b>9.</b> Chronic or active hepatitis <b>B as evidenced by positive serology testing (hepatitis B surface antigen [HBsAg], hepatitis B surface antibody [HBsAb], and hepatitis B core antibody [HBcAb]) and confirmatory HBV DNA testing. Refer to the Centers for Disease Control (CDC) table for the</b> interpretation of serological test results in the Laboratory Manual.</p> <p><b>10.</b> Active Hepatitis C as evidenced by detectable HCV RNA or currently on antiviral therapy.</p> <p><b>11.</b> Active malignancy, except non-melanoma skin cancer.</p> <p><b>12.</b> History of hepatic malignancy.</p> <p><b>13.</b> History of <b>arterial or venous thromboembolic events (eg, deep vein thrombosis, non-hemorrhagic stroke, pulmonary embolism, myocardial infarction, arterial embolus),</b> with the exception of catheter-associated thrombosis for which anti-thrombotic treatment is not currently ongoing.</p> <p><b>14. Known inherited or acquired thrombophilia, including conditions associated with increased thromboembolic risk, such as atrial fibrillation.</b></p> <p><b>15.</b> Treatment with any investigational product within 30 days or 5 half-lives of the investigational product prior to the screening period. For subjects who have received a <b>prior investigational product, all ongoing adverse events (AEs) experienced while</b> receiving that investigational product must have resolved prior to screening for this study.</p> <p><b>16.</b> Any condition that, in the opinion of the Investigator or Sponsor would prevent the patient <b>from fully complying with the requirements of the study (including possible corticosteroid treatment outlined in the protocol) and/or would impact or interfere with evaluation and</b> interpretation of subject safety or efficacy result.</p> <p><b>17.</b> Prior treatment with any vector or gene transfer agent.</p> <p><b>18.</b> Major surgery planned in the <b>52-week period following the infusion with BMN 270.</b></p> <p><b>19. Use of systemic immunosuppressive agents, not including corticosteroids,</b> or live vaccines within 30 days before the BMN 270 infusion.</p> <p><b>20. Concurrent enrollment in another clinical study, unless it is an observational (non-interventional) clinical study that does not interfere with the requirements of the current</b> protocol or have the potential to impact the evaluation of efficacy and safety of BMN 270 and with prior consultation with the Medical Monitor.</p> <p><b>21. Known allergy or hypersensitivity to BMN 270 investigational product formulation.</b></p> |   |  |

|  |   |  |
|--|---|--|
| <p><b>NAME OF COMPANY</b><br/>BioMarin Pharmaceutical Inc.<br/><b>105 Digital Drive</b><br/><b>Novato, CA 94949</b></p> <p><b>NAME OF FINISHED PRODUCT:</b><br/>BMN 270</p> <p><b>NAME OF ACTIVE INGREDIENT:</b><br/>AAV5-hFVIII-SQ</p>  | <p><b>SUMMARY TABLE</b><br/>Referring to Part of the<br/>Dossier:</p> <p>Volume:</p> <p>Page:</p> <p>Reference:</p> | <p><b>FOR NATIONAL<br/>AUTHORITY USE<br/>ONLY:</b></p> |
| <p>22. <b>Unwilling to receive blood or blood products for treatment of an adverse event and/or a bleeding episode.</b></p> <p><u>Optional Liver Biopsy Substudy Inclusion and Exclusion Criteria</u></p> <p>Individuals eligible for the optional liver biopsy must meet the following inclusion criterion:</p> <ol style="list-style-type: none"> <li>1. Able to sign informed consent <b>and comply with requirements for the optional liver biopsy</b></li> <li>2. <b>Documentation of FVIII activity level <math>\geq</math> 50 IU/dL (or higher, depending on local guidelines and/or Investigator discretion) within 24 hours prior to the liver biopsy being performed (FVIII activity levels should be assessed at the local laboratory). Subjects may be treated with additional exogenous FVIII replacement products in order to increase their FVIII activity to an appropriate level, under the supervision/instruction of the Investigator.</b></li> </ol> <p>Individuals who meet any of the following exclusion criteria will not be eligible for the optional liver biopsy:</p> <ol style="list-style-type: none"> <li>1. Any condition that, in the opinion of the Investigator or a hepatologist or radiologist, <b>would make</b> liver biopsy contraindicated. This includes <b>(but is not limited to):</b> abnormalities detected on liver ultrasound performed <b>within 28 days of procedure or prior liver ultrasound result within 90 days that would preclude safe performance of the biopsy.</b></li> </ol> |   |  |
| <p><b>INVESTIGATIONAL PRODUCT(S), DOSE, ROUTE AND REGIMEN:</b><br/><b>Each subject will receive a single intravenous infusion of BMN 270 at 6E13 vg/kg. The volume of infusion will depend on the subject's weight.</b></p>  |   |  |
| <p><b>REFERENCE THERAPY(IES), DOSE, ROUTE AND REGIMEN:</b><br/>No reference therapy will be evaluated in this study.</p>   |   |  |
| <p><b>DURATION OF TREATMENT:</b><br/>BMN 270 is given as a single dose by intravenous infusion.</p>  |   |  |
| <p><b>CRITERIA FOR EVALUATION:</b><br/><u>Efficacy:</u><br/>Primary efficacy endpoint:</p> <ul style="list-style-type: none"> <li>• Change of the hFVIII activity, as measured by chromogenic substrate assay, during <b>Weeks 49-52</b> post-BMN 270 infusion from baseline. Each subject's hFVIII activity during <b>Weeks 49-52 is defined as the median of the values obtained during this 4 week window.</b> Values for hFVIII activity will be excluded if obtained within 72 hours since the last infusion of exogenous FVIII protein concentrates.</li> </ul>  |   |  |

Secondary efficacy endpoints:

- **Change in the annualized utilization (IU/kg) of exogenous FVIII replacement therapy in the efficacy evaluation period (“Week 5 to Last Visit”) from the baseline utilization of exogenous FVIII replacement therapy.**
- **Change in the annualized number of bleeding episodes requiring exogenous FVIII replacement treatment (ABR) therapy in the efficacy evaluation period (“Week 5 to Last Visit”) from the baseline ABR.**

Tertiary efficacy endpoints:

- Change from baseline in the total score of Haemo-QoL-**A** at **Week 52** of the study post-BMN 270 infusion.
- Change from baseline in the EQ-5D-5L score at **Week 52** of the study post-BMN 270 infusion.
- **Change from baseline in the Haemophilia Activities List (HAL) score at Week 52** of the study post-BMN 270 infusion.
- **Change from baseline in the Work Productivity and Activity Impairment plus Classroom Impairment Questions: Hemophilia Specific (WPAI+CIQ:HS) score at Week 52** of the study post-BMN 270 infusion.
- **Change from baseline in Patient Reported Outcomes, Burdens, and Experiences (PROBE) score at Week 52** of the study post-BMN 270 infusion.

Safety:

The following safety outcome measurements will be assessed:

- **Incidence of adverse events (AEs) and serious AEs (SAEs)**
- **Change in clinical laboratory tests (serum chemistry and hematology)**
- Change in vital signs
- Change in physical examination
- **Vector shedding (blood, urine, semen, stool, saliva)**
- **Liver tests (LTs, including ALT, AST, GGT, direct and total bilirubin, lactate dehydrogenase [LDH], and alkaline phosphatase)**
- Immune response to FVIII transgene product and AAV5 capsid proteins

Each subject will have comprehensive surveillance monitoring of LTs (**once per week for Weeks 1-36, and then once every 2 weeks from Weeks 37-52) during Year 1.** LTs will be **monitored every four weeks during Year 2 and then every 6 weeks during Years 3-5 post-dose in the safety extension; the frequency and duration of LT testing may be changed** based on discussion **between the Medical Monitor and the Investigator, review of subject data, and/or by independent DMC feedback.**

There will be a detailed assessment of cellular and humoral responses to AAV5 capsid and FVIII protein.

Pharmacodynamics:

The FVIII protein concentration and activity level as measured by a validated immunoassay and a validated FVIII activity assay, respectively, will be used **for plasma profiles; FVIII protein and activity will be used to determine PD parameters.**



|   |   |  |
|---|---|--|
| <p><b>NAME OF COMPANY</b><br/>BioMarin Pharmaceutical Inc.<br/><b>105 Digital Drive</b><br/><b>Novato, CA 94949</b></p> <p><b>NAME OF FINISHED PRODUCT:</b><br/>BMN 270</p> <p><b>NAME OF ACTIVE INGREDIENT:</b><br/>AAV5-hFVIII-SQ</p>   | <p><b>SUMMARY TABLE</b><br/>Referring to Part of the<br/>Dossier:</p> <p>Volume:</p> <p>Page:</p> <p>Reference:</p> | <p><b>FOR NATIONAL<br/>AUTHORITY USE<br/>ONLY:</b></p> |
| <p><b>STATISTICAL METHODS:</b></p> <p><u>Sample Size</u></p> <p><b>Approximately one hundred and thirty (130) subjects may be dosed in the study. The sample size for this study is based on clinical and statistical considerations in order to provide sufficient data to assess both safety and efficacy of BMN 270.</b></p> <p><b>For the primary endpoint, a sample size of 130 will provide at least 95% power to demonstrate that the change in hFVIII activity during Weeks 49-52 from baseline is greater than 0, assuming an effect size of 0.6, using a one-sample t-test with a 2-sided significance level of 0.05.</b></p> <p>For the secondary endpoints, the analyses will be performed utilizing exogenous FVIII use and <b>bleeding episode data from the 110 subjects whose baseline data will be prospectively collected for approximately 6 months in the non-interventional study 270-902, prior to their enrollment in 270-301. An analytic sample size of 110 will provide at least 95% power to demonstrate that the change in the annualized utilization (IU/kg) of exogenous FVIII replacement therapy in the efficacy evaluation period (“Week 5 to Last Visit”) from baseline is less than 0, assuming an effect size of 0.6, using a one-sample t-test with a 2-sided significance level of 0.05.</b></p> <p><b>An analytic sample size of 110 will also have at least 95% power to demonstrate that the change in the annualized number of bleeding episodes requiring exogenous FVIII replacement treatment (ABR) in the efficacy evaluation period (“Week 5 to Last Visit”) from the baseline ABR is less than 3.5 (non-inferiority margin), assuming the pre- and post-BMN 270 infusion population mean ABRs are 3.5 and 1 respectively, using a one-sample t-test with a 2-sided significance level of 0.05. Under the same assumptions, a sample size of 110 will have approximately 90% power to demonstrate that the change is less than 0, ie, superiority of BMN 270 against FVIII prophylaxis.</b></p> <p><b>Overall, the planned sample size will have greater than 80% power for testing the primary and secondary efficacy endpoints hierarchically with a 2-sided significance level of 0.05.</b></p> <p><u>Analysis Population</u></p> <p>The intention-to-treat (ITT) population is defined as all subjects who receive BMN<sup>270</sup> infusion, and the modified intention-to-treat (mITT) population is defined as subjects who receive BMN<sup>270</sup> infusion and are HIV-negative. The mITT population will be used for the primary efficacy analysis, and the ITT population will be used for the supportive efficacy analysis. The ITT population will also be used for the safety analysis.</p> <p><u>Analysis</u></p> <p><b>For the primary efficacy endpoint at Week 52 (ie, the change in the hFVIII activity during Weeks 49-52 post-BMN<sup>270</sup> infusion from baseline, as measured by chromogenic substrate assay), a one-sample t-test will be used to test the null hypothesis that the change is 0 or less against the</b></p> |   |  |

| NAME OF COMPANY<br>BioMarin Pharmaceutical Inc.<br>105 Digital Drive<br>Novato, CA 94949<br><br>NAME OF FINISHED PRODUCT:<br>BMN 270<br><br>NAME OF ACTIVE INGREDIENT:<br>AAV5-hFVIII-SQ   | SUMMARY TABLE<br>Referring to Part of the<br>Dossier:<br><br>Volume:<br><br>Page:<br><br>Reference: | FOR NATIONAL<br>AUTHORITY USE<br>ONLY: |
|--|---|--|
| <p>alternative hypothesis that the change is greater than 0. Descriptive summaries of the proportions of subjects whose FVIII activity during Weeks 49-52 is greater than or equal to select thresholds, such as 15, 25 and 30 IU/dL, and the confidence intervals of the proportions will also be provided.</p> <p><b>For the secondary endpoints, the analyses will be performed on 110 subjects in the mITT population whose baseline data will be prospectively collected for approximately 6 months in the non-interventional study 270-902 prior to their enrollment in 270-301.</b></p> <p>For the first-ranked secondary efficacy endpoint (ie, the change in the annualized utilization (IU/kg) of exogenous FVIII replacement therapy in the efficacy evaluation period (“Week 5 to Last Visit”), a one-sample t-test will be performed to test the null hypothesis that the change is 0 or greater against the alternative hypothesis that the change is less than 0.</p> <p>For the second-ranked secondary efficacy endpoint (ie, the change in the annualized number of bleeding episodes requiring exogenous FVIII replacement treatment in the efficacy evaluation period (“Week 5 to Last Visit”), a one-sample t-test will be performed to test for non-inferiority of BMN 270 against FVIII prophylaxis (ie, the baseline ABR calculated using subjects’ data collected in 270-902) using a margin of 3.5, ie, to test the null hypothesis that the change is 3.5 or greater against the alternative hypothesis that the change is less than 3.5. If non-inferiority is demonstrated, the test for superiority of BMN 270 against FVIII prophylaxis will be performed.</p> <p>The primary efficacy endpoint and secondary efficacy endpoints will be tested hierarchically according to the order described above.</p> <p><b>Two interim analyses were planned, after approximately 16 and 20 treated HIV-negative subjects, respectively, completed the Week 26 visit (or have discontinued study participation prior to Week 26). The first interim analysis was performed as planned in May 2019. Based on the interim results and the totality of the data, the secondary interim analysis was deemed unnecessary. The DMC reviewed the interim analysis results to assess the efficacy and safety profiles, whether the pre-specified criteria of statistical significance has been achieved, and the risk/benefit ratio of the interventions in the BMN 270 studies based on the totality of the data. The primary efficacy endpoint for the interim analyses involves hFVIII activity, as measured by chromogenic substrate assay, achieved post-BMN 270 infusion, as detailed in the statistical analysis plan (SAP).</b></p> <p><b>The fallback procedure will be used to adjust for multiplicity of the two interim analyses at Week 26, the 1-year analysis at Week 52, and the 2-year analysis at Week 104 (regardless of the analyses results, the study is planned to continue for a total of approximately 5 years upon the DMC’s recommendation). At the 1-year analysis at Week 52 and the 2-year analysis at Week 104 the secondary efficacy endpoints will be tested hierarchically; the level of significance will be determined by the fallback procedure.</b></p> |   |  |



|   |   |  |
|---|---|--|
| <p><b>NAME OF COMPANY</b><br/>BioMarin Pharmaceutical Inc.<br/><b>105 Digital Drive</b><br/><b>Novato, CA 94949</b></p> <p><b>NAME OF FINISHED PRODUCT:</b><br/>BMN 270</p> <p><b>NAME OF ACTIVE INGREDIENT:</b><br/>AAV5-hFVIII-SQ</p>   | <p><b>SUMMARY TABLE</b><br/>Referring to Part of the<br/>Dossier:</p> <p>Volume:</p> <p>Page:</p> <p>Reference:</p> | <p><b>FOR NATIONAL<br/>AUTHORITY USE<br/>ONLY:</b></p> |
| <p><b>The secondary and tertiary endpoints will be summarized descriptively at the interim (Week 26) analyses.</b></p> <p>The details of the interim analyses, including the control of Type I error rate, will be specified in the SAP.</p> <p>Analysis of safety endpoints will be primarily descriptive. The incidence of AEs will be summarized by system organ class, preferred term, relationship to study drug, seriousness, and severity. Clinical laboratory test values, vital signs, vector shedding and immune response parameters will be summarized descriptively by visit.</p> |   |  |

### 3 TABLE OF CONTENTS

|  |    |
|--|----|
| <b>CLINICAL STUDY PROTOCOL AMENDMENT SUMMARY</b> .....                         | 2  |
| 2 SYNOPSIS.....  | 5  |
| 3 TABLE OF CONTENTS.....   | 19 |
| 4 LIST OF ABBREVIATIONS AND DEFINITIONS OF TERMS.....                          | 25 |
| 5 ETHICS.....  | 28 |
| <b>5.1 Institutional Review Board or Independent Ethics Committee</b> .....    | 28 |
| 5.2 Ethical Conduct of Study .....   | 28 |
| 5.3 Subject Information and Informed Consent.....                              | 29 |
| <b>6 INVESTIGATORS AND STUDY ADMINISTRATIVE STRUCTURE</b> .....                | 30 |
| 7 <b>INTRODUCTION</b> .....  | 31 |
| <b>7.1 Nonclinical Studies</b> .....   | 31 |
| 7.2 Ongoing Clinical Studies .....   | 32 |
| 7.3 Study Rationale.....   | 32 |
| <b>7.3.1 Optional Liver Biopsy Substudy Rationale</b> .....                    | 35 |
| <b>7.4 Summary of Overall Risks and Benefits</b> .....                         | 36 |
| <b>7.4.1 Optional Liver Biopsy Substudy Risks and Benefits</b> .....           | 37 |
| <b>8 STUDY OBJECTIVES</b> .....  | 39 |
| <b>9 INVESTIGATIONAL PLAN</b> .....  | 41 |
| <b>9.1 Overall Study Design and Plan</b> .....                                 | 41 |
| <b>9.2 Discussion of Study Design, Including Choice of Control Group</b> ..... | 61 |
| <b>9.3 Selection of Study Population</b> .....                                 | 61 |
| <b>9.3.1 Inclusion Criteria</b> .....  | 61 |
| <b>9.3.2 Exclusion Criteria</b> .....  | 62 |
| <b>9.3.3 Removal of Subjects from Treatment or Assessment</b> .....            | 64 |
| <b>9.3.4 Subject Identification and Replacement of Subjects</b> .....          | 66 |
| <b>9.3.5 Duration of Subject Participation</b> .....                           | 67 |
| <b>9.4 Treatments</b> .....  | 67 |
| <b>9.4.1 Treatments Administered</b> .....                                     | 67 |
| <b>9.4.2 Identity of Investigational Product</b> .....                         | 67 |

|        |   |    |
|--------|---|----|
| 9.4.3  | Storage.....  | 67 |
| 9.4.4  | Directions for Administration .....                                   | 67 |
| 9.4.5  | Method of Assigning Subjects to Treatment Groups .....                | 69 |
| 9.4.6  | <b>Selection of Dose Used in the Study</b> .....                      | 69 |
| 9.4.7  | Blinding.....   | 69 |
| 9.4.8  | Prior and Concomitant Medications.....                                | 70 |
| 9.4.9  | Treatment Compliance .....  | 76 |
| 9.5    | Investigational Product Accountability.....                           | 76 |
| 9.5.1  | Return and Disposition of Clinical Supplies .....                     | 76 |
| 9.6    | Dietary or Other Protocol Restrictions.....                           | 77 |
| 9.7    | Safety and Efficacy Variables.....                                    | 77 |
| 9.7.1  | Safety and Efficacy Measurements Assessed .....                       | 77 |
| 9.7.2  | Primary Efficacy Variables .....                                      | 77 |
| 9.7.3  | Secondary Efficacy Variables .....                                    | 78 |
| 9.7.4  | Tertiary Efficacy Variables .....                                     | 79 |
| 9.7.5  | Immunogenicity.....   | 80 |
| 9.7.6  | Pharmacodynamics.....   | 80 |
| 9.7.7  | Exploratory Assessments .....   | 80 |
| 9.7.8  | Safety Variables .....  | 82 |
| 10     | REPORTING ADVERSE EVENTS .....  | 89 |
| 10.1   | Safety Parameters and Definitions.....                                | 89 |
| 10.1.1 | Adverse Events.....   | 89 |
| 10.2   | Serious Adverse Events .....  | 90 |
| 10.2.1 | <b>Events of Special Interest (EOSI)</b> .....                        | 91 |
| 10.3   | Methods and Timing for Capturing and Assessing Safety Parameters..... | 91 |
| 10.3.1 | Adverse Event Reporting Period.....                                   | 91 |
| 10.3.2 | Eliciting Adverse Events .....  | 91 |
| 10.3.3 | Assessment of Seriousness, Severity, and Causality.....               | 91 |
| 10.4   | Procedures for Recording Adverse Events .....                         | 94 |
| 10.4.1 | Recording Adverse Events on an eCRF .....                             | 94 |
| 10.5   | <b>Reporting Requirements</b> .....                                   | 97 |

|         |   |     |
|---------|---|-----|
| 10.5.1  | <b>Expedited Reporting Requirements</b> .....   | 97  |
| 10.5.2  | Institutional Review Board or Independent Ethics Committee<br><b>Reporting Requirements</b> ..... | 98  |
| 10.6    | Follow-up of Subjects after Adverse Events.....   | 98  |
| 10.7    | Post-Study Adverse Events.....  | 99  |
| 10.8    | <b>Urgent Safety Measures</b> .....   | 99  |
| 10.9    | BioMarin Pharmacovigilance Contact Information.....   | 100 |
| 11      | APPROPRIATENESS OF MEASUREMENTS.....  | 101 |
| 12      | <b>STUDY PROCEDURES</b> .....   | 102 |
| 12.1    | Prestudy.....   | 102 |
| 12.2    | Screening Visit.....  | 102 |
| 12.2.1  | <b>“Smart Rescreening” Visit</b> .....  | 103 |
| 12.3    | Baseline Visit.....   | 104 |
| 12.4    | <b>Treatment Visit/BMN 270 Infusion Visit (Day 1)</b> .....                                       | 105 |
| 12.5    | <b>BMN 270 Infusion Follow-Up Visits – Weeks 1-26</b> .....                                       | 106 |
| 12.5.1  | <b>Once per week (Weeks 1 through 26)</b> .....   | 106 |
| 12.5.2  | <b>Week 1 – Day 4</b> .....   | 107 |
| 12.5.3  | <b>Week 1 – Day 8</b> .....   | 107 |
| 12.5.4  | <b>Every 2 Weeks (Week 2, 4, 6, 8, 10, 12, 14, 16, 18, 20, 22, 24, and 26)</b> .....              | 107 |
| 12.5.5  | <b>Weeks 2, 4, 10, 16, 22, and 26</b> .....   | 107 |
| 12.5.6  | <b>Weeks 2, 3, 4, 6, 8, 12, 16, 20, 24, and 26</b> .....  | 108 |
| 12.5.7  | <b>Weeks 4, 12, and 26</b> .....  | 108 |
| 12.5.8  | <b>Every 4 Weeks (Weeks 4, 8, 12, 16, 20, and 24) Plus Week 26</b> .....                          | 108 |
| 12.5.9  | <b>Every 8 Weeks (Weeks 8, 16, and 24)</b> .....  | 108 |
| 12.5.10 | <b>Weeks 6, 12, 16, 20, 24, and 26</b> .....  | 108 |
| 12.5.11 | <b>Weeks 12 and 26</b> .....  | 108 |
| 12.5.12 | <b>Week 16</b> .....  | 109 |
| 12.5.13 | <b>Week 20, 24, and 26</b> .....  | 109 |
| 12.6    | <b>Post-Infusion Follow-Up – Weeks 27-52</b> .....  | 109 |
| 12.6.1  | <b>Every Visit</b> .....  | 109 |
| 12.6.2  | <b>Weeks 28, 32, 36, 44, and 52</b> .....   | 110 |

|        |   |     |
|--------|---|-----|
| 12.6.3 | Every 4 Weeks (Weeks 28, 32, 36, 40, 44, 48, 52)                              | 110 |
| 12.6.4 | Weeks 32, 36, 44, and 52  | 110 |
| 12.6.5 | Weeks 32, 36, 40, 44, 48, and 52  | 111 |
| 12.6.6 | Week 32, 36, and 52   | 111 |
| 12.6.7 | Week 36 and 52  | 111 |
| 12.6.8 | Week 52   | 111 |
| 12.7   | Post-Infusion Follow-Up – Years 2-5   | 112 |
| 12.7.1 | Year 2 – Every 4 Weeks (not required for treatment failure)                   | 113 |
| 12.7.2 | Years 3-5 – Every 6 Weeks (not required for treatment failure)                | 113 |
| 12.7.3 | Years 2-5 – Every 12 Weeks and End of Year Visits (required for all subjects) | 114 |
| 12.8   | Early Termination Visit   | 116 |
| 12.9   | Optional Liver Biopsy   | 117 |
| 12.10  | End of Study  | 118 |
| 13     | DATA QUALITY ASSURANCE  | 119 |
| 14     | STATISTICAL METHODS AND DETERMINATION OF SAMPLE SIZE                          | 120 |
| 14.1   | Statistical and Analytical Plans  | 120 |
| 14.1.1 | Interim Analyses  | 120 |
| 14.1.2 | Procedures for Accounting for Missing, Unused and Spurious Data               | 120 |
| 14.2   | Primary Efficacy Endpoint   | 121 |
| 14.3   | Secondary Efficacy Endpoints  | 121 |
| 14.4   | Liver Biopsy Substudy Analysis  | 122 |
| 14.5   | Immunogenicity  | 122 |
| 14.6   | Pharmacodynamic Analyses  | 122 |
| 14.7   | Safety Analysis   | 122 |
| 14.8   | Determination of Sample Size  | 123 |
| 14.9   | Analysis Populations  | 124 |
| 14.10  | Changes in the Conduct of the Study or Planned Analyses                       | 124 |
| 15     | DATA MONITORING COMMITTEE   | 125 |
| 16     | COSTS, COMPENSATION, AND SUBJECT INJURY                                       | 126 |
| 17     | CASE REPORT FORMS AND SOURCE DOCUMENTS  | 127 |

|           |  |            |
|-----------|--|------------|
| <b>18</b> | <b>STUDY MONITORING AND AUDITING</b> .....   | <b>129</b> |
| <b>19</b> | <b>RETENTION OF RECORDS</b> .....  | <b>130</b> |
| <b>20</b> | <b>USE OF INFORMATION AND PUBLICATION</b> .....  | <b>131</b> |
| <b>21</b> | <b>REFERENCES</b> .....  | <b>132</b> |
| <b>22</b> | <b>INVESTIGATOR RESPONSIBILITIES</b> .....   | <b>135</b> |
|           | <b>22.1</b> Conduct of Study and Protection of Human Patients .....  | <b>135</b> |
| <b>23</b> | <b>SIGNATURE PAGE</b> .....  | <b>136</b> |
| <b>24</b> | <b>APPENDIX 1: SAMPSON'S ANAPHYLAXIS CRITERIA</b> .....  | <b>137</b> |
| <b>25</b> | <b>APPENDIX 2: REGION-SPECIFIC STUDY OBJECTIVES, ENDPOINTS,<br/>AND ANALYSES ("2-YEAR ANALYSIS") FOR THE UNITED STATES</b> ..... | <b>138</b> |
|           | <b>25.1</b> Region-Specific Study Objectives .....   | <b>138</b> |
|           | <b>25.2</b> Region-Specific Study Endpoints .....  | <b>139</b> |
|           | <b>25.3</b> Statistical Methods for the Analysis of Region-Specific Endpoints.....   | <b>140</b> |
|           | <b>25.3.1</b> Statistical Analysis Plan .....  | <b>140</b> |
|           | <b>25.3.2</b> Timing of Analysis .....   | <b>140</b> |
|           | <b>25.3.3</b> Data to be Included in the Analysis.....   | <b>140</b> |
|           | <b>25.3.4</b> Analysis Populations .....   | <b>140</b> |
|           | <b>25.3.5</b> Interim Analyses and Control of Type I Error Rate .....  | <b>141</b> |
|           | <b>25.3.6</b> Analysis Methods .....   | <b>143</b> |
| <b>26</b> | <b>PROTOCOL AMENDMENT TEXT REVISIONS</b> .....   | <b>146</b> |

## LIST OF TABLES

|                  |   |           |
|------------------|---|-----------|
| Table 9.1.1:     | <b>Schedule of Events</b> – Screening and Infusion .....                        | <b>44</b> |
| Table 9.1.2:     | <b>Schedule of Events</b> – Post-Infusion Follow-Up (Week 1-16).....            | <b>47</b> |
| Table 9.1.3:     | <b>Schedule of Events</b> – Post-Infusion Follow-Up (Week 17-32).....           | <b>50</b> |
| Table 9.1.4:     | <b>Schedule of Events</b> – Post-Infusion Follow-Up (Week 33 – Week 52).....    | <b>53</b> |
| Table 9.1.5:     | <b>Schedule of Events</b> – Post-Infusion Follow-Up (Year 2 – Year 5).....      | <b>56</b> |
| Table 9.1.6:     | <b>Schedule of Events</b> – Therapeutic Corticosteroids for ALT Elevations..... | <b>59</b> |
| Table 9.1.7:     | <b>Schedule of Events</b> – Optional Liver Biopsy .....                         | <b>60</b> |
| Table 9.4.8.2.1: | <b>Management of ALT Elevations with Reactive Corticosteroids</b> .....         | <b>74</b> |
| Table 9.4.8.2.2: | <b>Viral and Autoimmune Hepatitis Testing</b> .....                             | <b>75</b> |

---

|   |    |
|---|----|
| Table 9.7.8.2.1: Clinical Laboratory Tests .....              | 83 |
| Table 9.7.8.4.1: Liver Tests .....                            | 85 |
| Table 10.3.3.2.1: Adverse Event Grading (Severity) Scale..... | 92 |
| Table 10.3.3.3.1: Causality Attribution Guidance .....        | 93 |

**LIST OF FIGURES**

|  |    |
|--|----|
| Figure 1: hFVIII-SQ Vector Genome and Encoded Protein.....     | 7  |
| Figure 7.3.1: hFVIII-SQ Vector Genome and Encoded Protein..... | 34 |
| Figure 9.1.1: Study 270-301 Design.....                        | 41 |



#### 4 LIST OF ABBREVIATIONS AND DEFINITIONS OF TERMS

|             |   |
|-------------|---|
| AAV         | adeno-associated virus  |
| ABR         | annualized bleeding rate  |
| ADL         | activities of daily living  |
| ADR         | adverse drug reaction   |
| AE          | adverse event   |
| ALT         | alanine aminotransferase  |
| APTT        | activated partial thromboplastin time                             |
| ART         | anti-retroviral therapy   |
| AST         | aspartate aminotransferase  |
| BPV         | BioMarin Pharmacovigilance  |
| <b>BU</b>   | <b>Bethesda Unit</b>  |
| CFR         | Code of Federal Regulations                                       |
| CRA         | clinical research associate                                       |
| CRF         | case report form  |
| CSR         | clinical study report   |
| CTCAE       | Common Terminology Criteria for Adverse Events                    |
| DMC         | Data Monitoring Committee   |
| eCRF        | electronic case report form                                       |
| ED          | exposure days   |
| EOSI        | events of special interest  |
| ETV         | early termination visit   |
| EudraCT     | <b>European Union Drug Regulating Authorities Clinical Trials</b> |
| FDA         | Food and Drug Administration                                      |
| FIH         | first-in-human  |
| FVIII       | coagulation factor VIII   |
| GCP         | Good Clinical Practice  |
| GGT         | gamma-glutamyltransferase   |
| HA          | Hemophilia A  |
| HAL         | Haemophilia Activities List                                       |
| HBcAb       | hepatitis B core antibody   |
| HBsAb       | hepatitis B surface antibody                                      |
| HBsAg       | hepatitis B surface antigen                                       |
| <b>hFIX</b> | <b>human coagulation factor IX</b>                                |
| hFVIII      | human coagulation factor VIII                                     |
| HIPAA       | Health Insurance Portability and Accountability Act               |



|                    |  |
|--------------------|--|
| HLP                | hybrid human liver-specific promoter   |
| IB                 | investigator brochure  |
| ICF                | informed consent form  |
| ICH                | <b>International Conference on Harmonisation of Technical Requirements for Registration of Pharmaceuticals for Human Use</b> |
| <b>ICH E6 [R2]</b> | <b>ICH Harmonised Tripartite Guideline: Guideline for Good Clinical Practice E6</b>  |
| IEC                | independent ethics committee   |
| IND                | <b>Investigational New Drug (application)</b>  |
| INR                | international normalized ratio   |
| IP                 | investigational product  |
| IRB                | institutional review board   |
| ITT                | Intention-to-treat   |
| IV                 | intravenous  |
| LT                 | liver test   |
| MedDRA             | Medical Dictionary for Regulatory Activities   |
| mITT               | Modified intention-to-treat  |
| MN                 | mobile nursing   |
| PBMC               | peripheral blood mononuclear cells   |
| PCR                | polymerase chain reaction  |
| PD                 | pharmacodynamics   |
| PEG                | polyethylene glycol  |
| <b>PK</b>          | <b>Pharmacokinetics</b>  |
| PRO                | patient-reported outcome   |
| rhFVIII            | recombinant human FVIII protein  |
| REB                | research ethics board  |
| SAE                | serious adverse event  |
| SAP                | statistical analysis plan  |
| SDV                | source data verification   |
| SQ                 | <b>14-amino acid sequence: SFSQNPPVLKRHQR</b>  |
| TGA                | thrombin generation assay  |
| ULN                | upper limit of normal  |
| vg                 | vector genomes   |
| VWF:Ag             | von Willebrand factor Antigen  |
| <b>WPAI+CIQ:HS</b> | <b>Work Productivity and Activity Impairment plus Classroom</b> Impairment Questions: Hemophilia Specific                    |

**Definition of Terms:****Investigational Product (IP):**

**“A pharmaceutical form of an active ingredient or placebo being tested or used as a reference in a clinical trial, including a product with a marketing authorization when used or assembled (formulated or packaged) in a way different from the approved form, or when used for an unapproved indication, or when used to gain further information about an approved use” (from International Conference on Harmonisation of Technical Requirements for Registration of Pharmaceuticals for Human Use ICH Harmonised Tripartite Guideline: Guideline for Good Clinical Practice E6 [ICH E6 (R2)]).**

**The terms “IP” and “study drug” may be used interchangeably in the protocol.**

## 5 ETHICS

BioMarin Pharmaceutical Inc. (hereafter referred to as BioMarin or the Sponsor) conducts its studies according to the highest ethical and scientific standards. The following sections articulate standards to which Investigators will be held accountable, as well as matters of compliance to document adherence to such standards.

### 5.1 Institutional Review Board or Independent Ethics Committee

**Investigators are expected to interact with Ethics Committees (ECs) promptly, as required, during the course of the study. This includes, but is not limited to, providing appropriate documentation to support study initiation and maintaining appropriate flow of safety and other information during the course of the study and for study close-out activities. BioMarin (or designee) will assist Investigators with access to timely and accurate information and with assurance of prompt resolution of any queries.**

Prior to initiating the study, the Investigator will obtain written confirmation that the **institutional review board (IRB) or independent ethics committee (IEC) [for Canadian protocols, Research Ethics Board (REB)] is properly constituted and compliant with International Conference on Harmonisation of Technical Requirements for Registration of Pharmaceuticals for Human Use (ICH) and Good Clinical Practice (GCP) requirements, applicable laws and local regulations. A copy of the confirmation from the IRB/IEC/REB will be provided to BioMarin or its designee. The Investigator will provide the IRB/IEC/REB with all appropriate material, including the protocol, Investigator's Brochure (IB), the Informed Consent Form (ICF) including compensation procedures, and any other written information provided to the subjects, including all ICFs translated for patients who do not speak the local language at the clinical site. The study will not be initiated and Investigational Product (IP) supplies will not be shipped to the site until appropriate documents from the IRB/IEC/REB confirming unconditional approval of the protocol, the ICF and all subject recruitment materials are obtained in writing by the Investigator and copies are received at BioMarin or its designee. The approval document should refer to the study by protocol title and BioMarin protocol number (if possible), identify the documents reviewed, and include the date of the review and approval. BioMarin will ensure that the appropriate reports on the progress of the study are made to the IRB/IEC/REB and BioMarin by the Investigator in accordance with applicable guidance documents and governmental regulations.**

### 5.2 Ethical Conduct of Study

It is expected that Investigators understand and comply with the protocol. This includes, but is not limited to: establishing and meeting enrollment commitments, including providing

eligible subjects for study **enrollment; adhering to adverse event reporting, diagnostic, or other procedures as specified in the protocol; and assuring appropriate compliance with study treatment administration and accountability.**

This study will be conducted in accordance with the following:

- **European Clinical Trial Directive 2001/20/EC and Good Clinical Practice Directive 2005/28/EC, for studies conducted within any European country**
- **US Code of Federal Regulations (CFR) sections that address clinical research studies, and/or other national and local regulations, as applicable**
- **ICH Harmonised Tripartite Guideline: Guideline for Good Clinical Practice E6 (ICH E6) or E6(R2) (ICH E6R2) if adopted**

**Specifically, this study is based on adequately performed laboratory and animal experimentation and human Phase 1 study testing. The study will be conducted under a protocol reviewed and approved by an IRB/IEC/REB and will be conducted by scientifically and medically qualified persons. The potential benefits of the study are in proportion to the potential risks. The rights and welfare of the subjects will be respected and the Investigators conducting the study do not find the hazards to outweigh the potential benefits. Each subject will provide written, informed consent before any study-related tests or evaluations are performed.**

### **5.3 Subject Information and Informed Consent**

**A properly written and executed informed consent form (ICF), in compliance with ICH E6 (Section 4.8), United States Code of Federal Regulations (CFR) 21 CFR §50, European Clinical Trial Directive 2001/20/EC and Good Clinical Practice Directive 2005/28/EC, and other applicable local regulations, will be obtained for each subject prior to entering the subject into the study. The Investigator will prepare the ICF and provide the documents to BioMarin for approval prior to submission to the IRB/IEC/REB. BioMarin and the IRB/IEC/REB must approve the documents before they are implemented. A copy of the approved ICF, and if applicable, a copy of the approved subject information sheet and all ICFs translated to a language other than the native language of the clinical site must also be received by BioMarin or designee prior to any study-specific procedures being performed.**

The Investigator will provide copies of the signed ICF to each subject and will maintain the original in the record file of the subject.

## 6 INVESTIGATORS AND STUDY ADMINISTRATIVE STRUCTURE

During administration of informed consent, expectations regarding participation in the study should be made clear to subjects. Patients who are **not willing and/or are not able to comply** with all aspects of the study should not be encouraged to participate.

Prior to beginning the study, the Investigator at each site must provide to BioMarin or designee a fully executed and signed Statement of **Investigator (SOI) form**. **A US Food and Drug Administration (FDA) Form FDA 1572 serves as an acceptable SOI form. If Form FDA 1572 may not be used in a particular region, the Investigator must provide a fully executed SOI on the form provided by the Sponsor. All Investigators and Sub-Investigators must be listed on Form FDA 1572 or its equivalent SOI. Financial Disclosure Forms must also be completed for all Investigators and Sub-Investigators listed on the Form FDA 1572 or SOI who will be directly involved in the treatment or evaluation of subjects in this study.**

The study will be administered by and monitored by employees or representatives of **BioMarin. Clinical research associates (CRAs) or trained designees will monitor each site on a periodic basis and perform verification of source documentation for each subject as well as other required review processes. BioMarin's Regulatory Affairs Department (or designee) will be responsible for the timely reporting of serious adverse events (SAEs) to appropriate regulatory authorities as required.**

In multicenter studies, a Coordinating Investigator will be identified who will be responsible **for study overview. The Coordinating Investigator will read the clinical study report (CSR)** and confirm that it accurately describes the conduct and results of the study, to the best of his **or her knowledge. The Coordinating Investigator will be chosen on the basis of active** participation in the study, ability to interpret data, and willingness to review and sign the report in a specified timeframe. The identity of the Coordinating Investigator and a list of all Investigators participating in the study will be provided in the CSR.

Clinical Laboratory assessments will be performed at a nominated central laboratory. Bioanalytical samples will be sent to the appropriate specialty laboratories for testing. Refer to laboratory manual for more details.

## 7 INTRODUCTION

**Hemophilia A (HA) is an X-linked recessive bleeding disorder that affects approximately 1 in 5,000 males (Iorio 2019). It is caused by mutations in the factor VIII (FVIII) gene that codes for FVIII protein, an essential cofactor in the coagulation pathway. Clinical manifestations of severe FVIII deficiency are frequent unprovoked bleeding episodes in joints and soft tissues causing permanent disability and occasionally death mostly after brain hemorrhage. Treatment in Western countries (Berntorp 2012) consists of intravenous injection of plasma-derived or recombinant FVIII protein concentrates at the time of a bleed to control it or prophylactically to prevent bleeding episodes. The short half-life for FVIII (~8-12 hours) necessitates frequent infusions and makes this treatment prohibitively expensive for the majority of the world's hemophilia A patients. These individuals develop debilitating arthropathy and have a substantially increased risk of death from hemorrhage in life (Stonebraker 2010). Chemical modification or bioengineering of FVIII may improve half-life to 18-19 hours (Kaufman 2013). However, these extended half-life FVIII variants do not eliminate the need for lifelong FVIII protein administration (Hay 2012).**

Gene therapy offers the potential of disease-modifying therapy by continuous endogenous **production of human FVIII (hFVIII) following a single administration** of vector. Hemophilia A is well-suited for this approach because its clinical manifestations are attributable to the **lack of a single gene product (FVIII) that circulates in low amounts (100-200 ng/ml) in the plasma**. Tightly regulated control of gene expression is not essential, and a modest increase **in the level of FVIII (a plasma level of 2 ng/ml protein leads to a 1% expression) can ameliorate the severe phenotype (Srivastava 2020); thus, the therapeutic goal for gene therapy is a modest increase in hFVIII. Finally, the consequences of gene transfer can be assessed using simple quantitative rather than qualitative endpoints that can be easily assayed** in most clinical laboratories.

BMN 270 contains the cDNA for the B-domain-deleted SQ FVIII with a liver-specific HLP transcription promoter. The expression cassette is inserted between AAV2 ITRs, and this **genome is packaged in the AAV5 capsid. A comprehensive review of BMN 270** is contained in the IB supplied by BioMarin. Investigators are to review this document prior to initiating this study.

### 7.1 Nonclinical Studies

The nonclinical program supports a single IV infusion of BMN 270, the planned clinical route of administration, for the treatment of hemophilia A in male patients. This nonclinical **program took into account** the guidelines and reflection papers for gene therapy medicinal products under EMA Advanced Therapies as well as FDA guidance. The primary

pharmacodynamics (PD), pharmacokinetics (PK), and toxicity of IV BMN 270 were characterized in a series of single dose studies in species that were vector permissive and responsive to the transgene including normal CD-1 mice, a B- and T-cell deficient mouse model of hemophilia A (B6;129S-*F8<sup>tm1Kaz</sup>/J* x B6.129S6-*Rag2<sup>tm1Fwa</sup>* N12; FVIII KO x Rag2), and normal cynomolgus and rhesus monkeys. Some PD studies evaluated additional PK, immunogenicity and toxicity endpoints.

Results of the nonclinical program to date are detailed in the IB supplied by BioMarin. Investigators are to review this document prior to initiating this study.

## 7.2 Ongoing Clinical Studies

Ongoing clinical studies for BMN 270 include:

- 270-201, a phase 1/2, dose-escalation study in patients with severe HA
- 270-203, a phase 2 study in patients with severe HA who have anti-AAV5 antibody titers
- 270-205, a phase 1/2 study in patients with severe HA who have active or prior FVIII inhibitors
- 270-302, a phase 3 study in patients with severe HA who receive BMN 270 at the 4E13 vg/kg dose level
- 270-303, a phase 3 study in patients with severe HA who received BMN 270 at the 6E13 vg/kg dose level along with prophylactic corticosteroids

A comprehensive review of safety, efficacy, and immunogenicity results as of the latest data cut is contained in the IB supplied by BioMarin. Investigators are to review this document prior to initiating this study.

## 7.3 Study Rationale

**Hemophilia A (HA) is an X-linked recessive bleeding disorder that affects approximately 1 in 5,000 males. It is caused by deficiency in the activity of coagulation factor VIII (FVIII), an essential cofactor in the intrinsic coagulation pathway. This disorder can be either inherited, due to a genetic aberrancy or an acquired immunologic process, leading to insufficient quantities of FVIII or a dysfunctional FVIII, but all are characterized by a defective coagulation process. The clinical phenotype of HA patients generally correlates tightly with the level of residual expression. Severe HA is classified as FVIII activity less than 1% of wild type (< 1 IU/dL), moderate disease comprises 1-5% of wild-type activity and the mild form is 5-40% activity. The clinical manifestations of severe HA are frequent spontaneous bleeding episodes, predominantly in joints and soft tissues, with a substantially increased risk of death from hemorrhage when the brain is involved. Subjects with moderate**



disease can exhibit manifestations similar to those seen in patients with severe HA, resulting in a comparable bleeding phenotype.

Treatment of severe HA presently consists of intravenous injection of plasma derived or recombinant human FVIII protein (rhFVIII) concentrates both as prophylaxis 2-3 times per week, and at the time of a bleed, to prevent or control bleeding episodes, respectively. The half-life for FVIII (12 to 18 hours for most approved products) necessitates frequent infusions, and although a major advance in the treatment of HA, it remains common for severe HA patients to continue to have multiple bleeding events on prophylactic therapy (median ABR of 1.4 with prophylaxis treatment in a recently published retrospective observational study (Berntorp 2017) and between 1-2 in 6 prospective FVIII interventional studies) and on-demand-only therapy (median ABR of 4.5-18 in a recently published retrospective study (Berntorp 2017) and between 20-60 in 6 prospective FVIII interventional studies). The consequence of multiple bleeding events is the development of debilitating multiple-joint arthropathy and substantially increased risk of death. Chemical modification (eg, direct conjugation of polyethylene glycol (PEG) polymers) and bioengineering of FVIII (eg, FVIII-Fc fusion proteins) improve half-life by approximately 50%, and thus, show promise in reduced dosing and maintaining activity levels above 1% trough for a greater proportion of the dosing interval. However, these extended half-life FVIII variants remain dependent on multiple infusions to maintain critical levels of FVIII activity in severe HA patients. There is therefore a strong unmet need for a fully preventive treatment of HA to give patients a FVIII level compatible with a normal and hemorrhage-free life.

Gene therapy offers the potential of disease-modifying therapy by continuous endogenous production of active FVIII following a single intravenous infusion of a vector encoding the appropriate gene sequence for long-term episomal expression. Hemophilia A is well-suited for a gene replacement approach because clinical manifestations are attributable to the lack of a single gene product (FVIII) that circulates in minute amounts (200 ng/ml) in the plasma. Tightly regulated control of gene expression is not essential, and even modest increases in the level of FVIII (any increase of the plasma level by 2 ng/ml induces an increase in activity of 1%) can ameliorate the severe form of the disease. Thus, relatively small changes in endogenous FVIII activity can result in clinically relevant improvements in disease phenotype. Finally, the circulating FVIII response to gene transduction can be assessed using validated quantitative rather than qualitative endpoints that are easily assayed using established laboratory techniques.

Several different gene transfer strategies for FVIII replacement have been evaluated, but adeno-associated viral (AAV) vectors show the greatest promise. They have an excellent and well-defined safety profile, and can direct long term transgene expression with tropism and

Proprietary and Confidential



promoter specificity for specific tissues such as the liver (for serotypes 2, 5 and 8 among others). Indeed, an on-going gene therapy clinical trial for a related disorder, hemophilia B, has established that stable (median follow-up of 3.2 years) expression of human factor IX (hFIX) at levels that are sufficient for conversion of their bleeding phenotype from severe to moderate or mild is achievable following a single peripheral vein infusion of AAV8-hFIX vector. Several participants in this trial have been able to discontinue factor prophylaxis without suffering spontaneous hemorrhages, even when they undertook activities that previously resulted in bleeding. Thus, gene therapy treatment has resulted in a substantial improvement in their quality of life (Nathwani 2014).

BMN 270 is an AAV5-based gene therapy vector that expresses the SQ form of hFVIII under the control of a hybrid human liver-specific promoter (Figure 7.3.1).

Figure 7.3.1: hFVIII-SQ Vector Genome and Encoded Protein

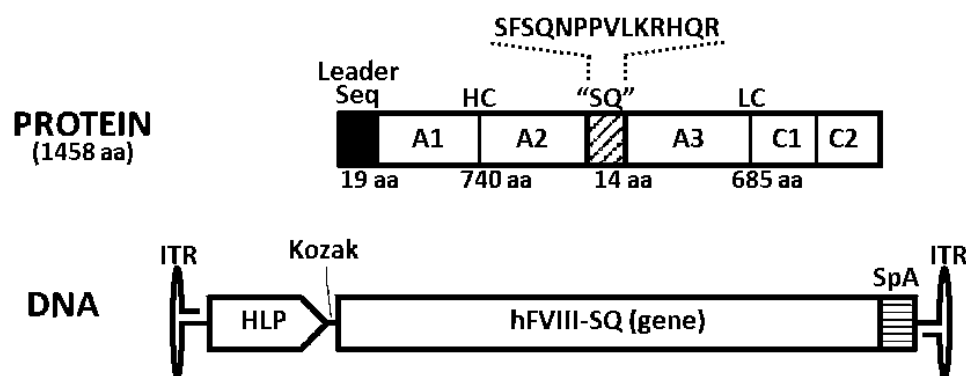

Legend – Note that schematic is not to scale; aa = amino acids; ITR = inverted terminal repeat; HLP = human liver promoter; Kozak = Kozak consensus sequence (GCCACC); SpA = Synthetic poly(A) signal

BMN 270 will be delivered by a single intravenous dose and is designed to achieve stable, potentially life-long expression of active hFVIII in the plasma, synthesized from vector-transduced liver tissue.

BMN 270 is being evaluated in clinical study 270-201, an ongoing first-in-human, phase 1/2 dose escalation study in subjects with severe HA designed to assess the safety and efficacy of BMN 270 at various dose levels (6E12 vg/kg, 2E13 vg/kg, 4E13 vg/kg, 6E13 vg/kg). Specifically, 270-201 explores the relationship of vector dose to the augmentation of residual FVIII activity and whether these levels are sufficient to alter the clinical phenotype. Four-year results from 270-201 have demonstrated that following gene transfer, mean and median FVIII activity levels above 15% (15 IU/dL), as measured by a chromogenic substrate assay, are achievable and sustained following a single infusion of 6E13 vg/kg of BMN 270, with an

**acceptable safety profile. Preliminary results from optional liver biopsies (in subjects receiving lower doses of BMN 270 in 270-201) confirm dose-dependent pan-lobular and otherwise healthy liver transduction at 2.7-4.1 years. For additional information on preliminary data in 270-201, refer to the current version of the Investigator's Brochure.**

The current study is a Phase 3, single-arm, open-label study designed to assess whether, in an expanded sample, BMN 270 can safely alter the clinical phenotype of hemophilia A patients **with residual FVIII activity  $\leq$  1 IU/dL.**

### 7.3.1 Optional Liver Biopsy Substudy Rationale

The usual pattern of response in hFVIII activity observed so far after administration of BMN 270 **demonstrates peak expression levels during the first 6-12 months post-treatment** followed by a decline to a steady-state level of expression thereafter. One of the explanations **may lie in the kinetics of vector genome processing, which involves a series of steps such as** DNA degradation and repair, annealing, and circularization that can result in the formation of stable, double-stranded, circularized transgene DNA forms. It is these circularized DNA species that are thought to be associated with long-term, persistent expression of the gene product in target cells. Examination of transduced hepatocytes from subjects treated with BMN 270 in the 270-301 study **will help to establish whether DNA circularization may occur** and could account for the long-term hFVIII expression observed in humans.

Additionally, health of the liver after gene transduction has been monitored indirectly by periodic assessments of hepatic enzymes released into the blood stream. Transient, post-treatment elevations in ALT levels have been observed in the majority of subjects, as well as inter-subject variability in post-therapy FVIII activity levels. Neither the reasons for nor the significance of the ALT elevations or the variations in response to FVIII gene therapy are **known. Moreover, the effects of BMN 270 on hepatic tissue structure and function are also currently unknown. Finally, a call to incorporate liver biopsy substudies into gene therapy trials for hemophilia has been issued by medical and scientific leaders in the field to help illuminate these and other questions (National Hemophilia Foundation 2019).**

The purpose of this exploratory substudy is to provide a better understanding of the long-term gene expression related to genome circularization, health of the liver, and variation in FVIII activity levels observed after gene therapy with BMN 270. With use of prophylactic corticosteroids, it is believed that there will be stable hepatic function and FVIII activity **expression, with tolerance of prophylactic corticosteroid therapy and no change to the risk of thromboembolism.** This substudy aims to evaluate the effect on the liver by performing liver biopsies **during Year 1 post-infusion, at or around Week 52, and/or during Years 2-5.**

#### 7.4 Summary of Overall Risks and Benefits

BMN 270 has an acceptable safety and tolerability profile that supports a positive benefit-risk assessment. **Single infusions have been generally well tolerated by treated subjects across all investigated doses. All subjects have successfully completed their full-dose infusion of BMN 270, with no infusions requiring permanent termination prior to completion due to AEs. No deaths have been reported in any of the BMN 270 studies, and no participants discontinued from studies as a result of an AE. Frequency of adverse events decreased over time with no delayed adverse drug reactions.**

Infusion reactions associated with BMN 270 administration included symptoms such as maculopapular rash, urticaria, nausea, diarrhea, watery eyes, rigors, chills, myalgia, fever, tachycardia and hypotension emerging **within 24 hours of receiving BMN 270. All of these events subsided without clinical sequelae within 48 hours following medical management** Infusion-related reactions were effectively mitigated by managing infusion rate and medications.

Transient, asymptomatic **ALT elevation (grade 1 to 3 in severity) was observed in most subjects administered BMN 270 shortly after dosing, with no symptoms or sequelae** suggestive of clinically significant hepatocyte injury or liver dysfunction. Across the **6E13 vg/kg cohort of 270-201 and 270-301, subjects enrolled in 270-201 developed ALT elevation about 5.5 weeks later than subjects in 270-301, generally once the first course of corticosteroids was being tapered, and experienced lower peak elevations in ALT (75.7 U/L) than subjects in 270-301 (112.5 U/L). The difference in the ALT profile seen between the 6E13 vg/kg subjects in 270-201 and the subjects in 270-301 could be attributed to the difference in the protocol-specified corticosteroid regimens in place in those studies, including the early use of corticosteroids (ie, by Week 3 post-BMN 270 infusion). While the majority of ALT elevations responded rapidly to corticosteroids, given current interest in the field of AAV gene therapy for the use of non-steroidal approaches to managing or preventing ALT elevations, alternate non-steroidal systemic immunosuppressive agents have also been used to manage hepatic reactions where corticosteroids have proven to be ineffective or where high doses/and or prolonged exposure to corticosteroids have led to unwanted side effects. Overall, the literature and clinical experience with BMN 270 suggests that transient elevations in liver enzymes are expected following AAV-based gene therapy for the treatment for hemophilia A or B without any long-term concerns of hepatic injury** ([Manno 2006](#); [Nathwani 2011](#); [George 2016](#); [Micsbach 2016](#); [Pasi 2020](#)).

At the highest dose tested in 270-201 (6E13 vg/kg), **the majority of subjects achieved FVIII levels above 50 IU/dL at 52 weeks post**-infusion. Subjects in that cohort also reported

**markedly decreased bleeding compared with pre-**study rates and the ability to discontinue prophylactic FVIII infusions. Subjects at all dose levels continue to be followed.

In 270-301, **an interim analysis has shown increased FVIII activity** in the majority of subjects **to mild HA or normal levels at 26 weeks post-infusion, also with markedly decreased** bleeding compared with pre-study rates and the ability to discontinue prophylactic FVIII infusions. **All subjects who were included in the 1-year analysis have been dosed with 6E13 vg/kg and continue to be followed.**

**The current data available has shown an established positive benefit:risk profile for BMN 270 at the 6E13 vg/kg dosing level. Given the monitoring measures in place in the clinical protocol(s) to minimize the risk to subjects participating in the existing studies, the identified risks are justified by the anticipated benefits that may be afforded to subjects.** Each subject in 270-301 **will have a comprehensive surveillance plan that monitors** LTs during the study, and elevations in LTs will be addressed according to the guidelines set forth in the protocol. Safety will be assessed by adverse event reporting and clinical laboratory assessments.

For additional information on the **risks and benefits of treatment with BMN 270, refer to the** current version of the Investigator's Brochure.

#### **7.4.1 Optional Liver Biopsy Substudy Risks and Benefits**

Liver biopsy is considered a safe procedure, with serious complications occurring less than once in **every 10,000 procedures (Grant 2004)**. **Although the theoretical risks of significant complications are extremely small, the main complications would include bleeding and bile leakage. Another theoretical complication is infection at the needle insertion site; the sterile technique used makes this risk extremely small.**

The most common problems include mild pain and a minor decrease in blood pressure. More serious complications, such as bleeding, infection, and injury to nearby organs, are very rare, but the subject will be monitored appropriately to ensure correct management should any of these occur. Any complications related to the liver biopsy should be reported as adverse events, as outlined in Section 10. The liver biopsy is a standard investigation, and will be explained more fully by the experienced clinician performing the biopsy.

Each subject who participates in this optional substudy will have a comprehensive pre-/post-biopsy surveillance plan according to the standard procedures at the institution. **Timing of the liver biopsies will occur at Weeks 26, 52, and/or during Years 2-5.** Safety will be assessed by adverse event reporting and clinical laboratory assessments. Per the **Investigator's discretion and/or according to local guidelines, the subject may be kept in**

**overnight following the liver biopsy for additional safety monitoring; such an overnight stay would not be considered a hospitalization for serious adverse event (SAE) reporting purposes (refer to Section 10.4.1.7).**

There is no direct benefit from participating in this study other than contributing to understanding the mechanism of action of BMN 270. Consenting into this specific substudy is optional and will not have any effect on the subject's continued participation in 270-301.

## 8 STUDY OBJECTIVES

The primary efficacy objective of the study is to:

- Assess the efficacy of BMN 270 defined as FVIII activity, as measured by **chromogenic substrate assay, during Weeks 49-52** following intravenous infusion of BMN 270

The secondary efficacy objectives of the study are to:

- Assess the impact of BMN 270 on usage of exogenous FVIII replacement therapy in **the efficacy evaluation period (from Week 5 to last visit by the data cutoff for the 1-year analysis, hereafter referred to as “Week 5 to Last Visit”)**
- Assess the impact of BMN 270 on the number of **bleeding episodes requiring exogenous FVIII replacement therapy in the efficacy evaluation period (“Week 5 to Last Visit”)**

The tertiary efficacy objective of the study is to:

- Assess the impact of BMN 270 on patient-**reported outcomes (PROs) at Week 52** of the study compared to baseline

The safety objectives of the study are to:

- Evaluate the safety of BMN 270 during the first **52 weeks following intravenous infusion**
- Assess the long-term safety of BMN 270

The exploratory objectives of the liver biopsy substudy are:

- To examine the histopathology of the liver following BMN 270 therapy, including **assessing for possible safety findings (eg, fibrosis, fatty liver disease, lymphocytic invasion)**
- To **quantify FVIII DNA, RNA, and protein expression within hepatocytes**
- To determine which forms of rAAV vector DNA are present at the time of biopsy.
- To **determine the transduction pattern of BMN 270 in humans (ie, peri-portal hepatocytes, central vein hepatocytes)**

The aforementioned study efficacy objectives were achieved through the pre-specified **analysis at Week 52 (“1-year analysis”) for the study, which was performed in January 2021 after all subjects had been followed for 52 weeks post-BMN 270 infusion (data cutoff date: 16 November 2020). Results from this analysis are intended** to support regulatory submissions to EMA and other health authorities outside of FDA.

**The FDA has requested BioMarin to submit 2-year safety and efficacy data on all subjects in 270-301 to enable their benefit-risk assessment of BMN 270. To fulfill this regulatory requirement, Appendix 2 has been created to specify region-specific study objectives for the United States and the associated endpoints and analyses to achieve them. This analysis (“2 year analysis”) will be performed after all subjects have completed the Week 104 visit or have withdrawn from the study.**



## 9 INVESTIGATIONAL PLAN

### 9.1 Overall Study Design and Plan

This is a Phase 3, single-arm, open-label study in hemophilia A patients with residual FVIII levels  $\leq 1$  IU/dL treated continuously with prophylactic exogenous FVIII for a minimum of one year prior to enrollment. **Subjects will be enrolled at approximately 60 sites worldwide.** Subjects must have high-quality, well-documented historical data available concerning previous **bleeding episodes and exogenous FVIII usage over the previous 12 months** in order to be eligible to enroll in the study.

**Approximately 130 adult subjects with severe HA will receive a 6E13 vg/kg dose of BMN 270 as a single intravenous infusion.** Approximately 20 subjects will enroll in the study **with at least 12 months of well-documented high-quality historical data concerning previous bleeding episodes and exogenous FVIII usage, while approximately 110 subjects will enroll in the study after having completed approximately 6 months' participation in the BioMarin-sponsored non-interventional study 270-902, in which bleeding and FVIII use data prior to gene therapy will be prospectively collected (Figure 9.1.1).**

Figure 9.1.1: Study 270-301 Design

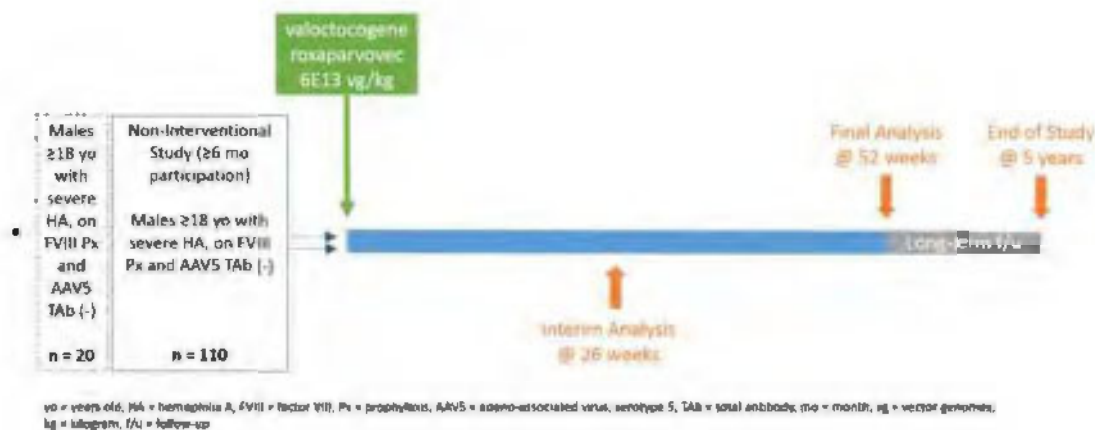

In order to minimize bias in the ongoing study and to assure safe and ethical conduct of the clinical trial, an **independent Data Monitoring Committee (DMC), consisting of experts in clinical trials, statistics, and hemophilia, has been convened.** The DMC will have sole access during the trial to amalgamated FVIII activity levels, FVIII usage, and bleeding data and will **review available safety and efficacy (eg, FVIII activity) data during the study on an ongoing basis; they may determine, based on emerging data and the risk/benefit profile, that further enrollment at 6E13 vg/kg should be discontinued in favor of a different dose of BMN 270, not to exceed 6E13 vg/kg.** If the DMC recommends a dosing modification, then additional



subjects may be enrolled, up to a total of approximately 130 subjects, at the new BMN 270 dose level (regardless of the number of subjects previously enrolled at 6E13 vg/kg).

Two interim analyses were planned, after the first approximately 16 and 20 treated HIV-negative subjects, respectively, completed the Week 26 visit (or have discontinued study participation prior to Week 26). The first interim analysis was performed as planned in May 2019. Based on the interim results and the totality of the data, the secondary interim analysis was deemed unnecessary. The DMC reviewed interim analysis results to assess the efficacy and safety profiles, whether the pre-specified criteria of statistical significance has been achieved, and the risk/benefit ratio of the interventions in the BMN 270 studies based on the totality of the data.

The 1-year analysis for the study was performed after all subjects had been followed for 52 weeks post-BMN 270 infusion. A separate 2-year analysis will also be performed per request from the FDA after all subjects have been followed for 104 weeks post-BMN 270 infusion. After the 1-year and the 2-year analyses, safety and efficacy will then continue to be assessed long-term in all subjects for a total of approximately 5 years.

To avoid breakthrough bleeding, subjects will only discontinue exogenous prophylactic FVIII replacement therapy after 4 weeks following infusion of BMN 270. Four weeks represents the time by which endogenous production of FVIII following gene transfer is expected to be efficacious, based on earlier results.

As the relationship between activity assay results of the BMN 270 gene product and bleeding remains to be established, Investigators should strive to minimize bias by avoiding consideration of FVIII activity levels by themselves or subjects in the reporting of bleeding episodes and FVIII usage.

In subjects who experience recurrent bleeding episodes, the Investigator and Medical Monitor will discuss whether to resume prior FVIII prophylaxis.

Subjects who do not respond to BMN 270 treatment (ie, treatment failure, manifesting as failure to achieve FVIII activity  $\geq 5$  IU/dL by Week 52 and inability to maintain independence from prophylactic FVIII replacement therapy due to joint bleeding episodes, in the judgment of the Investigator) may, at the Investigator's discretion and after discussion with the Medical Monitor or Sponsor-designated Data Monitor, follow an abbreviated visit schedule after Week 52 of the study by attending only the Q12W and End of Year visits during Years 2-5. Subjects who are not attending the Q4W/Q6W visits during Years 2-5 may receive a scheduled monthly follow-up telephone call from the site to ask about adverse events, concomitant medications, and bleeding events/FVIII replacement usage.

There will be an ongoing review of individual subject safety by the Medical Monitor, and both safety and efficacy data by the DMC. Therapeutic oral corticosteroids or other immunosuppressive agents may be initiated when a subject's ALT values are elevated, and **subsequent dosage adjustments made, after consultation between the Investigator and the Medical Monitor**. Management of ALT elevations is discussed in more detail in Section [9.4.8.2](#).

Any safety signal may trigger a review of the data and possible additional immunogenicity studies or other diagnostics deemed necessary that include an assessment of cellular immune responses using collected peripheral blood mononuclear cells (PBMCs).

**An optional liver biopsy will be performed as part of the liver biopsy substudy (in subjects who consent to do so) during Year 1 post-infusion, at or around Week 52, and/or during Years 2-5 following BMN 270 infusion.** Subjects who consent to the liver biopsy will have additional assessments, including a liver ultrasound and FibroScan, and will receive prophylactic FVIII prior to the procedure, as indicated in the judgment of the Investigator, to **minimize the risk of bleeding. Additional liver biopsies may be performed as part of the substudy during Years 2-5 as clinically indicated.**

Schedules of assessments for the **Screening and Infusion period** ([Table 9.1.1](#)), **Post-Infusion follow-up periods** ([Table 9.1.2](#), [Table 9.1.3](#), [Table 9.1.4](#), [Table 9.1.5](#)), **during the use of oral corticosteroids** ([Table 9.1.6](#)), and for the **optional liver biopsy** ([Table 9.1.7](#)) are presented below.

**Table 9.1.1: Schedule of Events – Screening and Infusion**

| Assessment   | Prior to BMN 270 Infusion      |  |  | BMN 270 Infusion Visit (Day 1) <sup>k</sup> |
|--|--------------------------------|--|--|---|
|  | Screening* (Day -28 to Day -1) | Smart Rescreening <sup>i</sup> (Day -28 to Day -1) | Baseline (Day -7 to Day -1) <sup>h</sup> |   |
| Informed consent   | X                              |  |  |   |
| <b>Demographics (age, sex, race, ethnicity)</b>  | X                              |  |  |   |
| Medical History  | X                              |  |  |   |
| Physical Examination <sup>a</sup>  | X                              |  | X  | X   |
| Height and Weight  | X                              |  |  |   |
| Vital Signs  | X                              | X  | X  | X   |
| Assessment of Adverse Events and Concomitant Medications   | X                              | X  | X  | X   |
| <b>Documentation of bleeding episodes and FVIII usage for previous 12 months (by either subject or clinical information)</b> | X                              | X  | X  |   |
| Distribution of subject diaries and training in their use <sup>l</sup>   | X                              |  |  |   |
| Electrocardiogram  | X                              |  |  |   |
| <b>Liver Ultrasound</b>  | X                              |  |  |   |
| hFVIII Assays <sup>b</sup>   | X                              | X <sup>j</sup>                                     | X  |   |
| AAV5 TAb Assays <sup>c</sup>   | X                              | X  | X  | X   |
| AAV5 TI Assay  |                                |  | X  |   |
| Screen for Hepatitis B, Hepatitis C, HIV <sup>d</sup>  | X                              |  |  |   |
| Blood chemistry, hematology, and coagulation tests <sup>e</sup>  | X                              | X  | X  |   |
| <b>Fasting lipid panel (blood triglycerides, total cholesterol, HDL cholesterol, and LDL cholesterol)</b>                    |                                |  |  | X   |
| <b>Urine Tests<sup>e</sup></b>   | X                              | X  | X  |   |
| Liver Tests <sup>e</sup>   | X                              | X  | X  |   |
| <b>PBMC collection (for baseline determination of AAV5 and FVIII specific cellular immunity)</b>                             |                                |  | X  |   |

| Assessment   | Prior to BMN 270 Infusion                  |  |  | BMN 270 Infusion Visit (Day 1) <sup>k</sup> |
|--|--|--|--|---|
|  | Screening <sup>a</sup> (Day -28 to Day -1) | Smart Rescreening <sup>i</sup> (Day -28 to Day -1) | Baseline (Day -7 to Day -1) <sup>h</sup> |   |
| Von Willebrand Factor Antigen (VWF:Ag)                       |  |  | X  |   |
| TGA Assay <sup>g</sup>                                       |  |  | X  |   |
| PCR of vector DNA in blood, saliva, urine, semen, and stools |  |  | X  | X   |
| Biomarker testing <sup>f</sup>                               | X  |  |  |   |
| Exploratory biomarker assessments <sup>e</sup>               |  |  | X  |   |
| Haemo-QOL-A assessment                                       |  |  | X  |   |
| EQ-5D-5L   |  |  | X  |   |
| HAL  |  |  | X  |   |
| WPAI+CIQ:HS  |  |  | X  |   |
| PROBE  |  |  | X  |   |
| BMN 270 Infusion   |  |  |  | X   |
| Hypersensitivity blood assessments <sup>m</sup>              |  |  |  | X <sup>m</sup>                              |

\* Screening assessments should be performed within 28 days of BMN 270 infusion (and must be performed within 42 days prior to BMN 270 infusion).

<sup>a</sup> Complete physical examination should be done at Screening. Brief physical examination may be done at Baseline and at the BMN 270 Infusion Visit.

<sup>b</sup> Includes baseline FVIII activity (chromogenic substrate FVIII assay and one-stage clotting FVIII assay), coagulation exploratory assay, hFVIII inhibitor level (Bethesda assay with Nijmegen modification), hFVIII total antibody titer, and hFVIII protein assay. Baseline activity should be assessed at trough (at least >72 hours after last dose of replacement FVIII therapy, or 5x the known half-life of the FVIII concentrates administered).

<sup>c</sup> Sample collection on the day of the infusion visit must be performed before the BMN 270 infusion is given. Screening, Smart Re-screening, and Infusion Day samples will be tested in an AAV5 TAb pre-screening assay specifically developed for enrolment purposes. Baseline and all post-dose samples will be tested in a different AAV5 TAb post-dose immunogenicity monitoring assay

<sup>d</sup> Patients with documented negative results within the last 30 days do not need to be retested. Hepatitis B screening should include hepatitis B surface antigen (HBsAg), hepatitis B surface antibody (HBsAb), and hepatitis B core antibody (HBcAb).

<sup>e</sup> Refer to [Table 9.7.8.2.1](#) for laboratory assessments to be included, and to [Table 9.7.8.4.1](#) for liver tests. ABO blood typing assessment should be performed at Baseline, or at another regularly scheduled visit prior to the end of the subject's participation in the study.

<sup>f</sup> Includes HLA genotyping and FVIII genotyping.

- <sup>g</sup> Blood samples will be collected to evaluate biochemical, molecular, cellular, and genetic/genomic aspects relevant to hemophilia A, coagulation, and/or AAV gene transfer, and to develop assays used for these evaluations. Subjects may choose to opt out of the exploratory genetic/genomic research being done to study or try to discover genes that are not yet known to be associated with hemophilia A. While exploratory samples will be collected at the time points indicated above, testing of these samples (including those for TGA assay and any other exploratory assessments) will be performed only as deemed necessary by the Sponsor.
- <sup>h</sup> Should the screening visit occur within 30 days of the drug infusion, physical examination, blood chemistry, LTs, hematology, urine tests, and coagulation tests do not need to be repeated at Baseline.
- <sup>i</sup> Smart rescreening should only be performed if a patient has been determined to be eligible for the study and is unable to complete the Baseline assessments and Infusion prior to the closing of the original Screening window. Subjects who undergo smart rescreening must complete the rescreening assessments and receive the infusion within 90 days of signing the original consent. Subjects who do not complete dosing within 90 days will be required to re-consent and undergo all screening procedures. Subjects may not undergo smart rescreening more than once.
- <sup>j</sup> Only the hFVIII inhibitor level (Bethesda assay with Nijmegen modification) assay must be done at smart rescreening.
- <sup>k</sup> With the exception of the collection of samples for PCR vector DNA analysis, assessments on the day of infusion must be performed prior to the infusion. Subjects will fast for at least 8 hours prior to pre-infusion laboratory sampling on the day of the infusion visit. On the day of the BMN 270 Infusion, vital signs will be monitored prior to the infusion, during the infusion every 15 minutes ( $\pm$  5 minutes), and following the infusion hourly ( $\pm$  5 minutes) for at least 8 hours during the subject's stay in the clinic. Shedding samples for PCR of vector DNA analysis (blood, saliva, urine, semen, stool) should be collected between 2 and 24 hours after the infusion has been completed.
- <sup>l</sup> Diaries should be distributed to subjects who have consented to participate in the study and who have been determined to meet all study eligibility criteria.
- <sup>m</sup> In case of hypersensitivity or adverse drug reaction, safety assessment, including physical examination and vital signs, will be done and additional blood samples will be collected within 1 hour of the hypersensitivity reaction (eg, tryptase, C3, C3a, C4, C5, C5a, and cytokine bead array, as well as possible additional exploratory testing) and samples for IgE and cytokine bead array (and possible additional exploratory testing) between 8-24 hours after the reaction, if possible. In addition, a blood sample should be taken 1 week after the hypersensitivity reaction for assessment of the cytokine bead array. In-patient observation can be extended and additional blood samples can be collected if deemed necessary at the discretion of the Investigator and Medical Monitor.

**Table 9.1.2: Schedule of Events – Post-Infusion Follow-Up (Week 1-16)**

| Assessment  | Follow-Up After BMN 270 Infusion – Weeks* |    |    |    |    |                |    |                |    |                |    |                 |    |                 |    |                 |     |
|---|---|----|----|----|----|----------------|----|----------------|----|----------------|----|-----------------|----|-----------------|----|-----------------|-----|
|   | Week 1                                    |    | 2  | 3  | 4  | 5 <sup>g</sup> | 6  | 7 <sup>g</sup> | 8  | 9 <sup>g</sup> | 10 | 11 <sup>g</sup> | 12 | 13 <sup>g</sup> | 14 | 15 <sup>g</sup> | 16  |
|   | D4  | D8 |    |    |    |                |    |                |    |                |    |                 |    |                 |    |                 |     |
| Study Day*  | 4   | 8  | 15 | 22 | 29 | 36             | 43 | 50             | 57 | 64             | 71 | 78              | 85 | 92              | 99 | 106             | 113 |
| Physical examination <sup>a</sup>   |   | X  | X  | X  | X  | X <sup>g</sup> | X  | X <sup>g</sup> | X  | X <sup>g</sup> | X  | X <sup>g</sup>  | X  | X <sup>g</sup>  | X  | X <sup>g</sup>  | X   |
| Weight <sup>a</sup>   |   |    |    |    | X  |                |    |                | X  |                |    |                 | X  |                 |    |                 | X   |
| Assessment of Adverse Events and Concomitant Medications (including review of subject diary for bleeding and FVIII use) | X   | X  | X  | X  | X  | X              | X  | X              | X  | X              | X  | X               | X  | X               | X  | X               | X   |
| Vital Signs   |   | X  | X  | X  | X  | X <sup>g</sup> | X  | X <sup>g</sup> | X  | X <sup>g</sup> | X  | X <sup>g</sup>  | X  | X <sup>g</sup>  | X  | X <sup>g</sup>  | X   |
| Blood chemistry, hematology, and coagulation tests <sup>b</sup>   |   |    | X  |    | X  |                |    |                |    |                | X  |                 |    |                 |    |                 | X   |
| Urine Tests <sup>b</sup>  |   |    |    |    |    |                |    |                |    |                |    |                 | X  |                 |    |                 |     |
| Liver Tests <sup>b</sup>  | X   | X  | X  | X  | X  | X              | X  | X              | X  | X              | X  | X               | X  | X               | X  | X               | X   |
| FVIII assays <sup>c</sup>   |   | X  | X  | X  | X  | X              | X  | X              | X  | X              | X  | X               | X  | X               | X  | X               | X   |
| FVIII antibody titer  |   |    |    |    | X  |                |    |                | X  |                |    |                 | X  |                 |    |                 | X   |
| PCR of vector DNA in blood, saliva, urine, semen, and stools <sup>d</sup>   | X   | X  | X  | X  | X  |                | X  |                | X  |                |    |                 | X  |                 |    |                 | X   |
| Exploratory biomarker assessments <sup>c</sup>  |   |    |    |    |    |                | X  |                |    |                |    |                 | X  |                 |    |                 | X   |
| Haemo-QOL-A assessment  |   |    |    |    | X  |                |    |                |    |                |    |                 | X  |                 |    |                 |     |
| EQ-5D-5L  |   |    |    |    | X  |                |    |                |    |                |    |                 | X  |                 |    |                 |     |
| HAL   |   |    |    |    | X  |                |    |                |    |                |    |                 | X  |                 |    |                 |     |
| WPAI+CIQ:HS   |   |    |    |    | X  |                |    |                |    |                |    |                 | X  |                 |    |                 |     |

| Assessment  | Follow-Up After BMN 270 Infusion – Weeks* |    |    |    |    |                |    |                |    |                |    |                 |    |                 |    |                 |                |
|---|---|----|----|----|----|----------------|----|----------------|----|----------------|----|-----------------|----|-----------------|----|-----------------|----------------|
|   | Week 1                                    |    | 2  | 3  | 4  | 5 <sup>g</sup> | 6  | 7 <sup>g</sup> | 8  | 9 <sup>g</sup> | 10 | 11 <sup>g</sup> | 12 | 13 <sup>g</sup> | 14 | 15 <sup>g</sup> | 16             |
|   | D4  | D8 |    |    |    |                |    |                |    |                |    |                 |    |                 |    |                 |                |
| Study Day*  | 4   | 8  | 15 | 22 | 29 | 36             | 43 | 50             | 57 | 64             | 71 | 78              | 85 | 92              | 99 | 106             | 113            |
| PROBE   |   |    |    |    | X  |                |    |                |    |                |    |                 | X  |                 |    |                 |                |
| AAV5 Tab Assay  |   |    |    |    |    |                |    |                | X  |                |    |                 |    |                 |    |                 | X              |
| AAV5 TI Assay   |   |    |    |    |    |                |    |                | X  |                |    |                 |    |                 |    |                 | X              |
| Testing for reactivation of hepatitis B and hepatitis C                 |   |    |    |    |    |                |    |                |    |                |    |                 |    |                 |    |                 | X <sup>f</sup> |
| PBMC collection (for determination of AAV5 and FVIII specific immunity) |   |    | X  |    | X  |                | X  |                | X  |                | X  |                 | X  |                 | X  |                 | X              |
| VWF:Ag  |   |    |    |    |    |                |    |                |    |                |    |                 | X  |                 |    |                 |                |

\* Visit windows are  $\pm$  48 hours (and include the Day 4 visit).

<sup>a</sup> Brief physical examination should be done at all weekly visits.

<sup>b</sup> Refer to [Table 9.7.8.2.1](#) for laboratory assessments to be included, and to [Table 9.7.8.4.1](#) for liver tests (LTs). LTs may be monitored more or less frequently (and in particular when ALT values are  $>$  ULN or  $\geq 1.5x$  baseline value) based on discussion between the Medical Monitor and the Investigator and review of subject data, but LTs will be monitored at least twice weekly during periods when a subject's ALT is  $\geq 3x$  ULN. Subjects with ALT  $>$  ULN or  $\geq 1.5x$  baseline value during the study and either an alternative etiology considered or for further evaluation of the lab abnormality may undergo additional evaluations (eg, imaging studies including MRI or ultrasound, additional blood tests, and/or liver biopsy) at the discretion of the Investigator. Additional testing of FVIII and LTs during any study week may be performed if: (1) the ALT has increased to above ULN; (2) Increases in ALT values from prior assessment are accompanied by declines in FVIII activity level; or after a discussion between the Medical Monitor and the Investigator based on a review of subject data. If FVIII levels and/or ALT values are stable over the course of several weeks, assessment of FVIII activity and ALT levels may be adjusted based on discussion between the Medical Monitor and the Investigator.

<sup>c</sup> Includes FVIII activity level (chromogenic substrate FVIII assay and one-stage clotting FVIII assay), Bethesda assay (with Nijmegen modification) for hFVIII inhibitor level, coagulation exploratory assay, and hFVIII protein assay. If a subject has used FVIII within 72 hours of a measurement day, all efforts should be made to obtain FVIII activity measurements when a 72-hour interval without FVIII use is achieved; the 72-hour wash-out period is only intended for subjects who have achieved FVIII  $\geq 5$  IU/dL at 16 weeks after BMN 270 infusion and who have not resumed FVIII replacement therapy. If FVIII levels are elevated or stable over the course of several weeks, assessment of FVIII activity may be adjusted based on discussion between the Medical Monitor and the Investigator. A D-dimer may be considered under circumstances in which FVIII activity levels are above the normal physiological range and/or if there is a concern for a venous thromboembolism.

<sup>d</sup> Collection for each matrix to occur until at least 3 consecutive results below the limit of detection are obtained. Collection and testing of semen samples must continue at least through Week 12, even if 3 consecutive results below the limit of detection in that compartment have already been recorded.

<sup>e</sup> Blood samples will be collected to evaluate biochemical, molecular, cellular, and **genetic/genomic aspects relevant to hemophilia A, coagulation, and/or AAV gene transfer, and to develop assays used for these evaluations. Subjects may choose to opt out of the exploratory genetic/genomic research being done to study or try to discover genes that are not yet known to be associated with hemophilia A.** While exploratory samples will be collected at the time points indicated above, testing of these **samples (including those for TGA assay and any other exploratory assessments) will be performed** only as deemed necessary by the Sponsor.

<sup>f</sup> **Testing for reactivation of hepatitis B and hepatitis C at Week 16, for subjects with a past medical history of hepatitis B or hepatitis C prior to study entry, should be performed only in subjects who have not received therapeutic oral corticosteroids prior to Week 16; subjects who have received therapeutic oral corticosteroids will have hepatitis B and hepatitis C testing at the time points indicated in [Table 9.1.6](#).**

<sup>g</sup> For subjects who have entered 270-301 following participation in 270-902, the scheduled visits at **Week 5, Week 7, Week 9, Week 11, Week 13, and Week 15 may be performed by a mobile nursing (MN) professional at the subject's home or another suitable location (if the subject has given written informed consent to participate in MN visits), or at the site as a shortened lab draw-only visit.** The MN service or site will collect blood samples at these visits. For site lab draw-only visits, sites will contact the subject via phone call or e-mail to collect information regarding adverse events, changes to concomitant medications, bleeding episodes, and FVIII use. For MN visits, the service will collect this information. The physical examination and vital signs assessments listed in the Schedule of Events will not be performed at these MN or lab draw-only visits for subjects who have entered **270-301 following participation in 270-902. In the event that neither** a lab-only visit or MN visit can be conducted within the visit window, the site should telephone the subject to collect adverse event, **concomitant medication, and diary data (bleeding events and FVIII usage).**



**Table 9.1.3: Schedule of Events – Post-Infusion Follow-Up (Week 17-32)**

| Assessment  | Follow-Up After BMN 270 Infusion – Weeks* |     |                 |     |                 |     |                 |     |                 |     |                 |     |                 |                 |                 |     |
|---|---|-----|-----------------|-----|-----------------|-----|-----------------|-----|-----------------|-----|-----------------|-----|-----------------|-----------------|-----------------|-----|
|   | 17 <sup>f</sup>                           | 18  | 19 <sup>f</sup> | 20  | 21 <sup>f</sup> | 22  | 23 <sup>f</sup> | 24  | 25 <sup>f</sup> | 26  | 27 <sup>f</sup> | 28  | 29 <sup>f</sup> | 30 <sup>f</sup> | 31 <sup>f</sup> | 32  |
| Study Day*  | 120                                       | 127 | 134             | 141 | 148             | 155 | 162             | 169 | 176             | 183 | 190             | 197 | 204             | 211             | 218             | 225 |
| Physical examination <sup>a</sup>   | X <sup>f</sup>                            | X   | X <sup>f</sup>  | X   | X <sup>f</sup>  | X   | X <sup>f</sup>  | X   | X <sup>f</sup>  | X   | X <sup>f</sup>  | X   | X <sup>f</sup>  | X <sup>f</sup>  | X <sup>f</sup>  | X   |
| Weight <sup>a</sup>   |   |     |                 | X   |                 |     |                 | X   |                 |     |                 | X   |                 |                 |                 | X   |
| Assessment of Adverse Events and Concomitant Medications (including review of subject diary for bleeding and FVIII use) | X   | X   | X               | X   | X               | X   | X               | X   | X               | X   | X               | X   | X               | X               | X               | X   |
| Vital Signs   | X <sup>f</sup>                            | X   | X <sup>f</sup>  | X   | X <sup>f</sup>  | X   | X <sup>f</sup>  | X   | X <sup>f</sup>  | X   | X <sup>f</sup>  | X   | X <sup>f</sup>  | X <sup>f</sup>  | X <sup>f</sup>  | X   |
| Blood chemistry, hematology, and coagulation tests <sup>b</sup>   |   |     |                 |     |                 | X   |                 |     |                 | X   |                 |     |                 |                 |                 | X   |
| Urine Tests <sup>b</sup>  |   |     |                 |     |                 |     |                 |     |                 | X   |                 |     |                 |                 |                 |     |
| Liver Tests <sup>b</sup>  | X   | X   | X               | X   | X               | X   | X               | X   | X               | X   | X               | X   | X               | X               | X               | X   |
| FVIII assays <sup>c</sup>   | X   | X   | X               | X   | X               | X   | X               | X   | X               | X   | X               | X   | X               | X               | X               | X   |
| FVIII antibody titer  |   |     |                 | X   |                 |     |                 | X   |                 | X   |                 |     |                 |                 |                 | X   |
| PCR of vector DNA in blood, saliva, urine, semen, and stools <sup>d</sup>   |   |     |                 | X   |                 |     |                 | X   |                 | X   |                 |     |                 |                 |                 | X   |
| Exploratory biomarker assessments <sup>e</sup>  |   |     |                 | X   |                 |     |                 | X   |                 | X   |                 |     |                 |                 |                 | X   |
| Haemo-QOL-A assessment  |   |     |                 |     |                 |     |                 |     |                 | X   |                 |     |                 |                 |                 |     |
| EQ-5D-5L  |   |     |                 |     |                 |     |                 |     |                 | X   |                 |     |                 |                 |                 |     |

| Assessment   | Follow-Up After BMN 270 Infusion – Weeks* |     |                 |     |                 |     |                 |     |                 |     |                 |     |                 |                 |                 |     |
|--|---|-----|-----------------|-----|-----------------|-----|-----------------|-----|-----------------|-----|-----------------|-----|-----------------|-----------------|-----------------|-----|
|  | 17 <sup>f</sup>                           | 18  | 19 <sup>f</sup> | 20  | 21 <sup>f</sup> | 22  | 23 <sup>f</sup> | 24  | 25 <sup>f</sup> | 26  | 27 <sup>f</sup> | 28  | 29 <sup>f</sup> | 30 <sup>f</sup> | 31 <sup>f</sup> | 32  |
| Study Day*   | 120                                       | 127 | 134             | 141 | 148             | 155 | 162             | 169 | 176             | 183 | 190             | 197 | 204             | 211             | 218             | 225 |
| HAL  |   |     |                 |     |                 |     |                 |     |                 | X   |                 |     |                 |                 |                 |     |
| WPAI+CIQ:HS  |   |     |                 |     |                 |     |                 |     |                 | X   |                 |     |                 |                 |                 |     |
| PROBE  |   |     |                 |     |                 |     |                 |     |                 | X   |                 |     |                 |                 |                 |     |
| AAV5 TAb Assay   |   |     |                 |     |                 |     |                 | X   |                 |     |                 |     |                 |                 |                 | X   |
| AAV5 TI Assay  |   |     |                 |     |                 |     |                 | X   |                 |     |                 |     |                 |                 |                 | X   |
| PBMC collection (for determination of AAV5 and FVIII specific cellular immunity) |   | X   |                 | X   |                 | X   |                 | X   |                 | X   |                 | X   |                 |                 |                 | X   |
| VWF:Ag   |   |     |                 |     |                 |     |                 |     |                 | X   |                 |     |                 |                 |                 |     |
| TGA Assay <sup>c</sup>   |   |     |                 | X   |                 |     |                 | X   |                 | X   |                 |     |                 |                 |                 | X   |
| Optional liver biopsy <sup>g</sup>   | Perform during Year 1                     |     |                 |     |                 |     |                 |     |                 |     |                 |     |                 |                 |                 |     |

\* Visit windows are ± 48 hours.

<sup>a</sup> Brief physical examination should be done at all weekly visits except Week 26, where a complete physical examination should be performed. Weight should be recorded at Week 20 and every 4 weeks.

<sup>b</sup> Refer to [Table 9.7.8.2.1](#) for laboratory assessments to be included, and to [Table 9.7.8.4.1](#) for liver tests (LTs). LTs may be monitored more or less frequently (and in particular when ALT values are > ULN or ≥ 1.5x baseline value) based on discussion between the Medical Monitor and the Investigator and review of subject data, but LTs will be monitored at least twice weekly during periods when a subject's ALT is ≥ 3x ULN. Subjects with ALT > ULN or ≥ 1.5x baseline value during the study and either an alternative etiology considered or for further evaluation of the lab abnormality may undergo additional evaluations (eg, imaging studies including MRI or ultrasound, additional blood tests, and/or liver biopsy) at the discretion of the Investigator. Additional testing of FVIII and LTs during any study week may be performed if: (1) the ALT has increased to above ULN; (2) Increases in ALT values from prior assessment are accompanied by declines in FVIII activity level; or after a discussion between the Medical Monitor and the Investigator based on a review of subject data. If FVIII levels and/or ALT values are stable over the course of several weeks, assessment of FVIII activity and ALT levels may be adjusted based on discussion between the Medical Monitor and the Investigator.

<sup>c</sup> Includes FVIII activity level (chromogenic substrate FVIII assay and one-stage clotting FVIII assay), Bethesda assay (with Nijmegen modification) for hFVIII inhibitor level, coagulation exploratory assay, and hFVIII protein. If a subject has used FVIII within 72 hours of a measurement day, all efforts should be made to obtain FVIII activity measurements when a 72-hour interval without FVIII use is achieved; the 72-hour wash-out period is only intended for subjects who have achieved FVIII ≥ 5 IU/dL at 16 weeks after BMN 270 infusion and who have not resumed FVIII replacement therapy. If FVIII levels are elevated or stable over the course of several weeks, assessment of FVIII activity may be adjusted based on discussion between

the Medical Monitor and the Investigator. A D-dimer may be considered under circumstances in which FVIII activity levels are above the normal physiological range and/or if there is a concern for a venous thromboembolism.

<sup>d</sup> Collection for each matrix to occur until at least 3 consecutive results below the limit of detection are obtained.

<sup>e</sup> **Blood samples will be collected to evaluate biochemical, molecular, cellular, and genetic/genomic aspects relevant to hemophilia A, coagulation, and/or AAV gene transfer, and to develop assays used for these evaluations. Subjects may choose to opt out of the exploratory genetic/genomic research being done to study or try to discover genes that are not yet known to be associated with hemophilia A. While exploratory samples will be collected at the time points indicated above, testing of these samples (including those for TGA assay and any other exploratory assessments) will be performed only as deemed necessary by the Sponsor.**

<sup>f</sup> For subjects who have entered 270-301 following participation in 270-902, the scheduled visits at Week 17, Week 19, Week 21, Week 23, Week 25, Week 27, Week 29, Week 30, and **Week 31 may be performed by a mobile nursing (MN) professional at the subject's home or another suitable location (if the subject has given written informed consent to participate in MN visits), or at the site as a shortened lab draw-only visit.** The MN service or site will collect blood samples at these visits. For site lab draw-only visits, sites will contact the subject via phone call or e-mail to collect information regarding adverse events, changes to concomitant medications, bleeding episodes, and FVIII use. For MN visits, the service will collect this information. The physical examination and vital signs assessments listed in the Schedule of Events will not be performed at these MN or lab draw-only visits for subjects who have entered 270-301 following participation in 270-902. **In the event that neither a lab-only visit or MN visit can be conducted within the visit window, the site should telephone the subject to collect adverse event, concomitant medication, and diary data (bleeding events and FVIII usage).**

<sup>g</sup> Subjects who elect to proceed will have a liver biopsy performed during Year 1 post-infusion. **Additional liver biopsies at times deemed to be clinically relevant (eg, decreasing FVIII at a time of increased ALT) may be pursued. Subjects will be asked to consent to the procedure for each liver biopsy performed during the study. Subjects should fast for at least 8 hours prior to liver ultrasound and optional liver biopsies.**

**Table 9.1.4: Schedule of Events – Post-Infusion Follow-Up (Week 33 – Week 52)**

| Assessment   | Year 1 – Weeks* |                 |                 |     |                 |     |                 |     |                 |     |                 |     |
|--|-----------------|-----------------|-----------------|-----|-----------------|-----|-----------------|-----|-----------------|-----|-----------------|-----|
|  | 33 <sup>f</sup> | 34 <sup>e</sup> | 35 <sup>f</sup> | 36  | 38 <sup>f</sup> | 40  | 42 <sup>f</sup> | 44  | 46 <sup>f</sup> | 48  | 50 <sup>f</sup> | 52  |
| Study Day*   | 232             | 239             | 246             | 253 | 267             | 281 | 295             | 309 | 323             | 337 | 351             | 365 |
| Physical examination <sup>a</sup>  | X <sup>f</sup>  | X <sup>f</sup>  | X <sup>f</sup>  | X   | X <sup>f</sup>  | X   | X <sup>f</sup>  | X   | X <sup>f</sup>  | X   | X <sup>f</sup>  | X   |
| Weight <sup>a</sup>  |                 |                 |                 | X   |                 | X   |                 | X   |                 | X   |                 | X   |
| Assessment of Adverse Events and Concomitant Medications<br>(including review of subject diary for bleeding and FVIII use) | X               | X               | X               | X   | X               | X   | X               | X   | X               | X   | X               | X   |
| Vital Signs  | X <sup>f</sup>  | X <sup>f</sup>  | X <sup>f</sup>  | X   | X <sup>f</sup>  | X   | X <sup>f</sup>  | X   | X <sup>f</sup>  | X   | X <sup>f</sup>  | X   |
| Blood chemistry, hematology, and coagulation tests <sup>b</sup>  |                 |                 |                 | X   |                 |     |                 | X   |                 |     |                 | X   |
| Urine Tests <sup>b</sup>   |                 |                 |                 | X   |                 |     |                 |     |                 |     |                 | X   |
| Liver Tests <sup>b</sup>   | X               | X               | X               | X   | X               | X   | X               | X   | X               | X   | X               | X   |
| FVIII assays <sup>c</sup>  | X               | X               | X               | X   | X               | X   | X               | X   | X               | X   | X               | X   |
| AAV5 TAb Assay   |                 |                 |                 | X   |                 |     |                 |     |                 |     |                 | X   |
| AAV5 TI Assay  |                 |                 |                 | X   |                 |     |                 |     |                 |     |                 | X   |
| FVIII antibody titer   |                 |                 |                 | X   |                 |     |                 | X   |                 |     |                 | X   |
| Exploratory biomarker assessments <sup>d</sup>   |                 |                 |                 | X   |                 | X   |                 | X   |                 | X   |                 | X   |
| PBMC Collection (for determination of FVIII and Capsid specific<br>cellular immunity)                                      |                 |                 |                 | X   |                 |     |                 | X   |                 |     |                 | X   |
| VWF:Ag   |                 |                 |                 | X   |                 |     |                 |     |                 |     |                 | X   |
| TGA Assay <sup>d</sup>   |                 |                 |                 | X   |                 | X   |                 | X   |                 | X   |                 | X   |
| PCR of vector DNA in blood, saliva, urine, semen, and stools <sup>e</sup>  |                 |                 |                 | X   |                 | X   |                 | X   |                 | X   |                 | X   |
| Haemo-QOL-A assessment   |                 |                 |                 |     |                 |     |                 |     |                 |     |                 | X   |
| EQ-5D-5L   |                 |                 |                 |     |                 |     |                 |     |                 |     |                 | X   |
| HAL  |                 |                 |                 |     |                 |     |                 |     |                 |     |                 | X   |
| WPAI+CIQ:HS  |                 |                 |                 |     |                 |     |                 |     |                 |     |                 | X   |
| PROBE  |                 |                 |                 |     |                 |     |                 |     |                 |     |                 | X   |

| Assessment                         | Year 1 – Weeks*       |                 |                 |    |                 |    |                 |    |                 |    |                 |    |
|------------------------------------|-----------------------|-----------------|-----------------|----|-----------------|----|-----------------|----|-----------------|----|-----------------|----|
|                                    | 33 <sup>f</sup>       | 34 <sup>e</sup> | 35 <sup>f</sup> | 36 | 38 <sup>f</sup> | 40 | 42 <sup>f</sup> | 44 | 46 <sup>f</sup> | 48 | 50 <sup>f</sup> | 52 |
| Optional liver biopsy <sup>g</sup> | Perform during Year 1 |                 |                 |    |                 |    |                 |    |                 |    |                 | X  |

\* Visit windows are  $\pm$  48 hours through Week 36, then  $\pm$ 1 week until Week 52

<sup>a</sup> Complete physical examination should be performed at Week 52; brief physical exam may be performed at other study visits. Weight should be recorded at Week 36 and every 4 weeks through Week 52.

<sup>b</sup> Refer to [Table 9.7.8.2.1](#) for laboratory assessments to be included, and to [Table 9.7.8.4.1](#) for liver tests. LTs may be monitored more or less frequently (and in particular when ALT values are  $>$  ULN or  $\geq 1.5x$  baseline value) based on discussion between the Medical Monitor and the Investigator and review of subject data, but LTs will be monitored at least twice weekly during periods when a subject's ALT is  $\geq 3x$  ULN. Subjects with ALT  $>$  ULN or  $\geq 1.5x$  baseline value during the study and either an alternative etiology considered or for further evaluation of the lab abnormality may undergo additional evaluations (eg, imaging studies including MRI or ultrasound, additional blood tests, and/or liver biopsy) at the discretion of the Investigator. Additional testing of FVIII and LTs during any study week may be performed if: (1) the ALT has increased to above ULN or increased by  $> 10$  U/L from prior assessment; (2) Increases in ALT values from prior assessment are accompanied by declines in FVIII activity level; or after a discussion between the Medical Monitor and the Investigator based on a review of subject data. If FVIII levels and/or ALT values are stable over the course of several weeks, assessment of FVIII activity and ALT levels may be adjusted based on discussion between the Medical Monitor and the Investigator.

<sup>c</sup> Includes FVIII activity level (chromogenic substrate FVIII assay and one-stage clotting FVIII assay), Bethesda assay (with Nijmegen modification) for hFVIII inhibitor level, coagulation exploratory assay, and hFVIII protein assay. If a subject has used FVIII within 72 hours of a measurement day, all efforts should be made to obtain FVIII activity measurements when a 72-hour interval without FVIII use is achieved; the 72-hour wash-out period is only intended for subjects who have achieved FVIII  $\geq 5$  IU/dL at 16 weeks after BMN 270 infusion and who have not resumed FVIII replacement therapy. If FVIII levels are elevated or stable over the course of several weeks, assessment of FVIII activity may be adjusted based on discussion between the Medical Monitor and the Investigator. A D-dimer may be considered under circumstances in which FVIII activity levels are above the normal physiological range and/or if there is a concern for a venous thromboembolism.

<sup>d</sup> Blood samples will be collected to evaluate biochemical, molecular, cellular, and genetic/genomic aspects relevant to hemophilia A, coagulation, and/or AAV gene transfer, and to develop assays used for these evaluations. Subjects may choose to opt out of the exploratory genetic/genomic research being done to study or try to discover genes that are not yet known to be associated with hemophilia A. While exploratory samples will be collected at the time points indicated above, testing of these samples (including those for TGA assay and any other exploratory assessments) will be performed only as deemed necessary by the Sponsor.

<sup>e</sup> Collection for each matrix to occur until at least 3 consecutive results below the limit of detection are obtained.

<sup>f</sup> For subjects who have entered 270-301 following participation in 270-902, the scheduled visits at Week 33, Week 34, Week 35, Week 38, Week 42, Week 46, and Week 50 may be performed by a mobile nursing (MN) professional at the subject's home or another suitable location (if the subject has given written informed consent to participate in MN visits), or at the site as a shortened lab draw-only visit. The MN service or site will collect blood samples at these visits. For site lab draw-only visits, sites will contact the subject via phone call or e-mail to collect information regarding adverse events, changes to concomitant medications, bleeding episodes, and FVIII use. For MN visits, the service will collect this information. The physical examination and vital signs assessments listed in the Schedule of Events will not be performed at these MN or lab draw-only visits for subjects who have entered 270-301 following participation in 270-902. In the event that neither a lab-only visit or MN visit can be conducted within the visit window, the site should telephone the subject to collect adverse event, concomitant medication, and diary data (bleeding events and FVIII usage).

---

<sup>g</sup> Subjects who elect to proceed will have a liver biopsy performed **during Year 1 post-infusion, at or around Week 52**. Additional liver biopsies at times deemed to be clinically relevant (eg decreasing FVIII at a time of increased ALT) may be pursued. Subjects will be asked to consent to the procedure for each liver biopsy performed during the study. Subjects should fast for at least **8** hours prior to liver ultrasound and optional liver biopsies.

Table 9.1.5: Schedule of Events – Post-Infusion Follow-Up (Year 2 – Year 5)

| Assessment   | Years 2-5*                   | Year 2*          | Years 3-5*       | End of Year Visit |                  |                |                | ETV              |
|--|------------------------------|------------------|------------------|-------------------|------------------|----------------|----------------|------------------|
|  | Q12W                         | Q4W <sup>i</sup> | Q6W <sup>j</sup> | Year 2<br>W104    | Year 3<br>W156   | Year 4<br>W208 | Year 5<br>W260 |                  |
| Physical examination <sup>a</sup>  | X <sup>a</sup>               |                  |                  |                   | X <sup>a</sup>   |                |                | X                |
| Weight <sup>a</sup>  | X <sup>a</sup>               |                  |                  |                   | X <sup>a</sup>   |                |                | X                |
| Assessment of Adverse Events and Concomitant Medications<br>(including review of subject diary for bleeding and FVIII use) | X                            | X                | X                |                   | X                |                |                | X                |
| Vital Signs  | X                            |                  |                  |                   | X                |                |                | X                |
| Blood chemistry, hematology, and coagulation tests <sup>b</sup>  | X <sup>b</sup>               |                  |                  |                   | X                |                |                | X                |
| Urine Tests <sup>b</sup>   | X <sup>b</sup>               |                  |                  |                   | X                |                |                | X                |
| Liver Tests <sup>b</sup>   | X                            | X                | X                |                   | X                |                |                | X                |
| FVIII assays <sup>c</sup>  | X                            | X                | X                |                   | X                |                |                | X                |
| FVIII protein assay  | X                            |                  |                  |                   | X                |                |                | X                |
| AAV5 TAb Assay <sup>d</sup>  | X (Year 2 only) <sup>d</sup> |                  |                  |                   | X                |                |                | X                |
| FVIII antibody titer <sup>d</sup>  | X (Year 2 only) <sup>d</sup> |                  |                  |                   | X                |                |                | X                |
| AAV5 TI Assay <sup>c</sup>   |                              |                  |                  |                   | X <sup>c</sup>   |                |                | X <sup>c</sup>   |
| PBMC Collection (for determination of FVIII and Capsid specific<br>cellular immunity)                                      | X                            |                  |                  |                   | X                |                |                | X                |
| VWF:Ag   | X                            |                  |                  |                   | X                |                |                | X                |
| PCR of vector DNA in semen <sup>f</sup>  | (X) <sup>f</sup>             | (X) <sup>f</sup> | (X) <sup>f</sup> |                   | (X) <sup>f</sup> |                |                | (X) <sup>f</sup> |
| PCR of vector DNA in blood, saliva, urine, and stools <sup>f</sup>   | (X) <sup>f</sup>             |                  |                  |                   | (X) <sup>f</sup> |                |                | (X) <sup>f</sup> |
| Exploratory biomarker assessments <sup>g</sup>   | X                            |                  |                  |                   | X                |                |                | X                |
| Haemo-QOL-A assessment   | X <sup>h</sup>               |                  |                  |                   | X <sup>h</sup>   |                |                | X                |
| EQ-5D-5L   | X <sup>h</sup>               |                  |                  |                   | X <sup>h</sup>   |                |                | X                |
| HAL  | X <sup>h</sup>               |                  |                  |                   | X <sup>h</sup>   |                |                | X                |
| WPAI+CIQ:HS  | X <sup>h</sup>               |                  |                  |                   | X <sup>h</sup>   |                |                | X                |

| Assessment                         | Years 2-5*     | Year 2* | Years 3-5*       | End of Year Visit |                |                |                | ETV |                |
|------------------------------------|----------------|---------|------------------|-------------------|----------------|----------------|----------------|-----|----------------|
|                                    | Study Week*    | Q12W    | Q4W <sup>i</sup> | Q6W <sup>j</sup>  | Year 2<br>W104 | Year 3<br>W156 | Year 4<br>W208 |     | Year 5<br>W260 |
| PROBE                              | X <sup>h</sup> |         |                  |                   |                | X <sup>h</sup> |                |     | X              |
| Liver ultrasound <sup>i</sup>      |                |         |                  |                   |                | X              |                |     | X              |
| Optional liver biopsy <sup>k</sup> |                |         |                  |                   |                | X              |                |     |                |

ETV: Early Termination Visit

\* Visit windows are  $\pm 2$  weeks for visits in Years 2-5. At applicable sites, the Q4W (during Year 2) and Q6W (during Years 3-5) assessments may be conducted by a trained mobile nursing (MN) professional at the subject's home or another suitable location, if the subject has given written informed consent to participate in mobile nursing visits. Q12W and End of Year visits during Years 2-5 cannot be done by a MN professional and must be done at the study site.

<sup>a</sup> Complete physical examination should be performed at the End of Year visits (genitourinary examination may be deferred); brief physical exam may be performed at other study visits. Weight should be recorded at the second Q12W visit each year and at every End of Year visit during Years 2-5.

<sup>b</sup> Refer to [Table 9.7.8.2.1](#) for laboratory assessments to be included, and to [Table 9.7.8.4.1](#) for liver tests. LT assessment may be checked more frequently when ALT values are  $> \text{ULN}$  or  $\geq 1.5x$  baseline value or based upon discussion between the Medical Monitor and the Investigator. Subjects with ALT  $> \text{ULN}$  or  $\geq 1.5x$  baseline value during the study and either an alternative etiology considered or for further evaluation of the lab abnormality may undergo additional evaluations (eg, imaging studies including MRI or ultrasound, additional blood tests, and/or liver biopsy) at the discretion of the Investigator. Additional testing of FVIII and LTs during any study week may be performed if: (1) the ALT has increased to above ULN or increased by  $> 10$  U/L from prior assessment; or (2) after a discussion between the Medical Monitor and the Investigator based on a review of subject data. If ALT values are stable over the course of several weeks, assessment of FVIII activity and ALT levels may be adjusted based on discussion between the Medical Monitor and the Investigator. During Years 2-5 of the Post-Infusion Follow-Up period, urine tests and blood, chemistry, and coagulation tests should be performed at the second Q12W visit each year and at every End of Year visit.

<sup>c</sup> Includes FVIII activity level (chromogenic substrate FVIII assay and one-stage clotting FVIII assay), Bethesda assay (with Nijmegen modification) for hFVIII inhibitor level, and coagulation exploratory assay. If a subject has used FVIII within 72 hours of a measurement day, all efforts should be made to obtain FVIII activity measurements when a 72-hour interval without FVIII use is achieved; the 72-hour wash-out period is only intended for subjects who have achieved FVIII  $\geq 5$  IU/dL at 16 weeks after BMN 270 infusion and who have not resumed FVIII replacement therapy. If FVIII levels are elevated or stable over the course of several weeks, assessment of FVIII activity may be adjusted based on discussion between the Medical Monitor and the Investigator. A D-dimer may be considered under circumstances in which FVIII activity levels are above the normal physiological range and/or if there is a concern for a venous thromboembolism. If a subject tests positive in the Bethesda assay (with Nijmegen modification) during Years 3-5, a fresh sample should be collected within 4 weeks of the initial visit that had a positive result.

<sup>d</sup> AAV5 TAb assay and FVIII antibody titer collection should be performed quarterly through the end of Year 2, and then at End of Year Visits during Years 3-5.

<sup>e</sup> AAV5 TI Assay should be performed only at the end of the study (either the Year 5 End of Year Visit, or at the ETV for subjects who withdraw prior to the end of Year 5).

<sup>f</sup> Sample testing during Long-Term Follow-Up is not required if at least 3 consecutive samples were below the limit of detection during the Post-Infusion Follow-Up period. Subjects who have not had 3 consecutive semen samples below the limit of detection by Week 52 should continue to have PCR testing of semen every 4 weeks (during Year 2) or every 6 weeks (during Years 3-5) until 3 consecutive samples below the limit of detection are documented (or upon consultation between the Investigator and Medical Monitor).



- <sup>g</sup> Blood samples will be collected to evaluate biochemical, molecular, cellular, and genetic/genomic aspects relevant to hemophilia A, coagulation, and/or AAV gene transfer, and to develop assays used for these evaluations. Subjects may choose to opt out of the exploratory genetic/genomic research being done to study or try to discover genes that are not yet known to be associated with hemophilia A. While exploratory samples will be collected at the time points indicated above, testing of these samples (including those for exploratory assessments) will be performed only as deemed necessary by the Sponsor.
- <sup>h</sup> PRO assessments during Years 2-5 of Long-Term Follow-up should be performed at the second Q12W visit each year and at every End of Year visit.
- <sup>i</sup> Additional liver ultrasounds may be performed at interim timepoints (ie, between the End of Year visits) at the discretion of the Investigator.
- <sup>j</sup> Subjects who meet the definition of treatment failure to BMN 270 therapy after Week 52 may omit the Q4W and Q6W visits during Years 2-5, and must attend only the Q12W and End of Year visits. Subjects who are not attending the Q4W/Q6W visits during Years 2-5 may receive a scheduled monthly follow-up telephone call from the site to ask about adverse events, concomitant medications, and bleeding events/FVIII replacement usage. Such subjects following the abbreviated schedule who have not yet cleared vector shedding in one or more matrices must still provide samples in the uncleared matrix Q4W (during Year 2) or Q6W (during Years 3-5) until vector shedding has been cleared, either by reporting to the site to provide samples or by providing those samples to a MN professional.
- <sup>k</sup> An optional liver biopsy may be performed at any time between Years 2-5 of the study. The optional biopsy may be triggered by a FVIII activity decline by > 50% from steady-state, over 2 consecutive measurements, or by a sustained ALT rise > ULN. If neither triggered is observed, the optional biopsy may be performed at the end of Year 5. Subjects should fast for at least 8 hours prior to liver ultrasound and optional liver biopsies. More than one liver biopsy may be performed during this period, as clinically indicated.

Table 9.1.6: Schedule of Events – Therapeutic Corticosteroids for ALT Elevations

|   | Steroid Treatment Period <sup>b</sup> |        |        |        |        |        |        |                     | Post-Steroid Period <sup>c</sup> |        |        |        |         |
|---|---------------------------------------|--------|--------|--------|--------|--------|--------|---------------------|----------------------------------|--------|--------|--------|---------|
|   | Week 1                                | Week 2 | Week 3 | Week 4 | Week 5 | Week 6 | Week 7 | Week 8 <sup>b</sup> | Week 1                           | Week 2 | Week 3 | Week 4 | Week 13 |
| Therapeutic corticosteroids (dose in mg/day) <sup>a</sup> | 60 mg                                 | 60 mg  | 40 mg  | 40 mg  | 40 mg  | 30 mg  | 20 mg  | 10 mg               |                                  |        |        |        |         |
| FVIII activity testing                                    |                                       |        |        |        |        |        |        |                     | X                                | X      | X      | X      |         |
| Liver tests   |                                       |        |        |        |        |        |        |                     | X                                | X      | X      | X      |         |
| Hepatitis B testing <sup>d</sup>                          |                                       |        |        |        |        | X      |        |                     | X                                |        |        |        | X       |
| HCV Viral Load <sup>d</sup>                               |                                       |        |        |        |        | X      |        |                     | X                                |        |        |        | X       |

<sup>a</sup> Therapeutic oral corticosteroids may be initiated according to the parameters set out in Section 9.4.8.2.

<sup>b</sup> Following initiation or completion of steroid regimen, if a recurrence of ALT values  $> \text{ULN}$  or  $\geq 1.5\times$  baseline value is reported, steroid management decisions will be based on discussions between the Investigator and Medical Monitor. Modification of the steroid regimen may take into consideration timing of ALT elevation (after Week 52), as well as possible confounders for the ALT elevation, and adverse events related to steroid dosing. Guidance for tapering oral corticosteroid dosing can be found in Section 9.4.8.2.

<sup>c</sup> After discontinuation of oral corticosteroids, weekly labs for ALT and FVIII levels will be measured once a week for 4 weeks to ensure stability in values. If these assessments are already being done as part of normal study follow-up, they do not need to be duplicated.

<sup>d</sup> Should only be performed in subjects with a history of hepatitis B or hepatitis C prior to study entry.

**Table 9.1.7: Schedule of Events – Optional Liver Biopsy**

|   | Within 28 Days Before<br>Biopsy Day | Within 7 Days Before<br>Biopsy Day | Biopsy Day (BD) |
|---|-------------------------------------|------------------------------------|-----------------|
| Informed Consent for Liver Biopsy Procedure                 | X                                   |                                    |                 |
| Liver Ultrasound <sup>a</sup>                               | X                                   |                                    |                 |
| Physical examination  | X                                   |                                    | X               |
| Hematology, Coagulation, Chemistry Assessments <sup>b</sup> | X                                   |                                    | X               |
| Liver Tests <sup>b</sup>                                    | X                                   |                                    | X               |
| FibroScan   | X                                   |                                    |                 |
| FVIII Activity Level Assessment (central and local)         |                                     | X                                  | X <sup>e</sup>  |
| Exploratory CK18 and Grp78 assessment                       |                                     | X                                  | X <sup>e</sup>  |
| Pre-Biopsy Consultation <sup>c</sup>                        |                                     | X                                  |                 |
| Liver Biopsy <sup>d</sup>                                   |                                     |                                    | X               |
| PBMC Collection (whole blood draw)                          |                                     |                                    | X <sup>e</sup>  |

If Day -28 assessments are already performed as part of a scheduled on-site study visit, they do not need to be duplicated here.

\* If the Day -7 and biopsy day visits occur on the same day, these tests do not need to be duplicated.

<sup>a</sup> Liver ultrasound must be performed within 28 days prior to the scheduled biopsy. Subjects should fast for at least 8 hours prior to liver ultrasound.

<sup>b</sup> Refer to [Table 9.7.8.2.1](#) for laboratory assessments to be included, and to [Table 9.7.8.4.1](#) for liver tests.

<sup>c</sup> Subjects will undergo a pre-biopsy consultation with the Investigator (treating hematologist) and hepatologist and/or radiologist.

<sup>d</sup> Subjects should fast for at least 8 hours prior to optional liver biopsy. Biopsy will be a percutaneous or transjugular biopsy under ultrasound guidance, performed according to the standard procedure of the institution. If only a small amount of tissue (< 2 cm) is obtained at the time of the biopsy, the subject may be asked to consent for a second pass. In this case, the original < 2 cm sample should still be retained and handled according to the instructions for handling biopsy specimens in the Laboratory Manual. Following completion of the biopsy, the subject should remain in the hospital under observation for at least 4-6 hours. Overnight post-procedure observation may be done at the investigator's discretion.

<sup>e</sup> Blood draw for PBMC collection should be performed on the biopsy day or ± 1 week from the biopsy day.

## 9.2 Discussion of Study Design, Including Choice of Control Group

Study 270-301 is designed to be a Phase 3, single-arm, open-label study in hemophilia A patients with residual FVIII levels  $\leq 1$  IU/dL previously treated with prophylactic exogenous FVIII. Hemophilia A patients who provide written informed consent, meet the entry criteria definition of residual FVIII activity, have well-documented historical data for the previous 12 months concerning exogenous FVIII usage and bleeding episodes, and do not have antibodies to AAV5 will be eligible to enroll in the study.

Approximately 130 subjects will be enrolled at the 6E13 vg/kg BMN 270 dose. Subjects will initially be followed for 52 weeks post-BMN 270 infusion, during which safety and efficacy assessments will be taken. The 1-year analysis for the study will be performed after all subject have been followed for 52 weeks post-BMN 270 infusion. A separate 2-year analysis will also be performed per request from the FDA after all subjects have been followed for 104 weeks post-BMN 270 infusion. After the 1-year and 2-year analyses, safety and efficacy will then continue to be assessed long-term in all subjects for a total of approximately 5 years. During enrollment, the DMC will review available safety and efficacy data on an ongoing basis and may decide to recommend dosing subjects at a different dose level (not to exceed 6E13 vg/kg) based on emerging data from 270-301 and their overall benefit:risk assessment.

Study 270-301 is a self-controlled study. Parameters for each subject will be compared to a pre-treatment assessment of safety (liver function) and efficacy (number of bleeds, use of FVIII replacement therapy).

## 9.3 Selection of Study Population

Approximately 130 adult hemophilia A patients with residual FVIII levels  $\leq 1$  IU/dL may enroll into the study.

Additional criteria for participation in the study are provided in Section 9.3.1 and Section 9.3.2.

### 9.3.1 Inclusion Criteria

Individuals eligible to participate in this study must meet all of the following inclusion criteria:

1. Males  $\geq 18$  years of age with hemophilia A and residual FVIII levels  $\leq 1$  IU/dL as evidenced by medical history, at the time of signing the informed consent.
2. Must have been on prophylactic FVIII replacement therapy for at least 12 months prior to study entry. High-quality, well-documented historical data concerning bleeding episodes and FVIII usage over the previous 12 months must be available.

3. **Treated/exposed to FVIII concentrates or cryoprecipitate for a minimum of 150 exposure days (EDs).**
4. Willing and able to provide written, signed informed consent after the nature of the study has been explained and prior to any study-related procedures.
5. No previous documented history of a detectable FVIII inhibitor, and results from a Bethesda assay or Bethesda assay with Nijmegen modification of less than **0.6 Bethesda Units (BU) (or less than 1.0 BU for laboratories with a historical lower sensitivity cutoff for inhibitor detection of 1.0 BU) on 2 consecutive occasions at least one week apart within the past 12 months (at least one of which should be tested at the central laboratory).**
6. Sexually active participants must agree to use an acceptable method of effective contraception, either **double-barrier contraception (ie, condom + diaphragm; or condom or diaphragm + spermicidal gel or foam) or their female partner either using hormonal contraceptives or having an intrauterine device.** Participants must agree to **contraception use for at least 12 weeks post-infusion; after 12 weeks, subjects may stop contraception use only if they have had 3 consecutive semen samples with viral vector DNA below the limit of detection.**
7. Willing to abstain from alcohol consumption for at least the first **52 weeks following BMN 270 infusion.**

### 9.3.2 Exclusion Criteria

Individuals who meet any of the following exclusion criteria will not be eligible to participate in the study:

1. Detectable pre-existing antibodies to the AAV5 capsid.
2. Any evidence of active infection or any immunosuppressive disorder, including HIV infection.
3. Significant liver dysfunction with any of the following abnormal laboratory results:
  - **ALT (alanine aminotransferase) > 1.25x ULN;**
  - **AST (aspartate aminotransferase) > 1.25x ULN;**
  - **GGT (gamma-glutamyltransferase) > 1.25x ULN;**
  - **Total bilirubin > 1.25x ULN;**
  - **Alkaline phosphatase > 1.25x ULN; or**
  - **INR (international normalized ratio)  $\geq$  1.4.**

Subjects whose liver laboratory assessments fall outside of these ranges may undergo repeat testing of the entire liver test panel within the same Screening window and, if eligibility criteria are met on retest, may be enrolled after confirmation by the Medical Monitor.

4. **Prior liver biopsy showing significant fibrosis of 3 or 4 as rated on a scale of 0-4 on the Batts-Ludwig (Batts 1995) or METAVIR (Bedossa 1996) scoring systems, or an equivalent grade of fibrosis if an alternative scale is used.**
5. Evidence of any bleeding disorder not related to hemophilia A.
6. **Platelet count of  $< 100 \times 10^9/L$ .**
7. **Creatinine  $\geq 1.5$  mg/dL.**
8. Liver cirrhosis of any etiology as assessed by liver ultrasound.
9. **Chronic or active hepatitis B as evidenced by positive serology testing (HBsAg, HBsAb, and HBcAb) and confirmatory HBV DNA testing. Refer to the Centers for Disease Control (CDC) table for the interpretation of serological test results in the Laboratory Manual.**
10. Active Hepatitis C as evidenced by detectable HCV RNA or currently on antiviral therapy.
11. Active malignancy, except non-melanoma skin cancer.
12. History of hepatic malignancy.
13. **History of arterial or venous thromboembolic events (eg, deep vein thrombosis, non-hemorrhagic stroke, pulmonary embolism, myocardial infarction, arterial embolus), with the exception of catheter-associated thrombosis for which anti-thrombotic treatment is not currently ongoing.**
14. **Known inherited or acquired thrombophilia, including conditions associated with increased thromboembolic risk, such as atrial fibrillation.**
15. Treatment with any investigational product within 30 days or 5 half-lives of the investigational product prior to the screening period. For subjects who have received **a prior investigational product, all ongoing adverse events (AEs) experienced while receiving that investigational product must have resolved prior to screening for this study.**
16. Any condition that, in the opinion of the Investigator or Sponsor would prevent the **patient from fully complying with the requirements of the study (including possible corticosteroid treatment outlined in the protocol) and/or would impact or interfere with evaluation and interpretation of subject safety or efficacy result.**
17. Prior treatment with any vector or gene transfer agent.
18. Major surgery planned in the **52-week period following the infusion with BMN 270.**
19. **Use of systemic immunosuppressive agents, not including corticosteroids, or live vaccines within 30 days before the BMN 270 infusion.**

20. Concurrent enrollment in another clinical study, unless it is an observational **(non-interventional) clinical study that does not interfere with the requirements of** the current protocol or have the potential to impact the evaluation of efficacy and safety of BMN 270 and with prior consultation with the Medical Monitor.
21. **Known allergy** or hypersensitivity to BMN 270 investigational product formulation.
22. **Unwilling to receive blood or blood products for treatment of an adverse event and/or a bleeding episode.**

### 9.3.2.1 Optional Liver Biopsy Inclusion and Exclusion Criteria

Individuals eligible for the optional liver biopsy must meet the following inclusion criterion:

1. **Able to sign informed consent and comply with requirements for the optional liver biopsy**
2. **Documentation of FVIII activity  $\geq$  50 IU/dL (or higher, depending on local guidelines and/or Investigator discretion) within 24 hours prior to the liver biopsy being performed (FVIII activity levels should be assessed at the local laboratory). Subjects may be treated with additional exogenous FVIII replacement products in order to increase their FVIII levels activity to an appropriate level, under the supervision/instruction of the Investigator.**

Individuals who meet any of the following exclusion criteria will not be eligible for the optional liver biopsy:

1. Any condition that, in the opinion of **the Investigator or a hepatologist/radiologist would make liver biopsy contraindicated. This includes (but is not limited to)** abnormalities detected on liver ultrasound performed **within 28 days of procedure, or prior liver ultrasound result within 90 days** that would preclude safe performance of the biopsy.

### 9.3.3 Removal of Subjects from Treatment or Assessment

Subjects may withdraw their consent to participate in the study at any time without prejudice.

The Investigator must withdraw from the study any subject **who requests to be withdrawn.**

**Such subjects will always be asked about the reason(s) for withdrawal. The Investigator will discuss with the subject appropriate procedures for withdrawal from the study.**

The **Investigator should ask the subject's consent to** perform the procedures listed under the early termination visit. Should a subject withdraw from the study, all efforts will be made to complete and report the observations as thoroughly as possible up to the date of the withdrawal.

A subject's participation in the study may be discontinued at any time at the discretion of **BioMarin or of the Investigator and in accordance with his/her clinical judgment. When**



possible, the tests and evaluations listed for the termination visit should be carried out and every effort will be made to gather follow-up safety data if possible.

BioMarin must be notified of all subject withdrawals as soon as possible. BioMarin also reserves the right to discontinue the study at any time for either clinical or administrative reasons and to discontinue participation by an individual Investigator or site for poor enrollment or noncompliance.

Reasons for which the Investigator or BioMarin may withdraw a subject from the study include, but are not limited to, the following:

- **Subject requires medication or medical procedure prohibited by the protocol**
- **Subject does not adhere to study requirements specified in the protocol**
- Subject was erroneously enrolled into the study or does not meet entry criteria and not yet been dosed with **BMN 270; subjects who do not meet entry criteria but who erroneously receive BMN 270** should remain in the study for safety monitoring
- Subject is lost to follow-up

If a subject fails to return for scheduled visits, a documented effort must be made to determine the reason. If the subject cannot be reached by telephone, a certified letter should **be sent to the subject requesting contact with the Investigator. This information should be recorded in the study records.**

Subjects may be considered lost to follow-up if the subject has missed 3 consecutive visits in the study and has failed to communicate a reason for this to the site. In addition, the site has **documented at least 4 attempted contacts by key research personnel to reach the subject** without success in the following manner:

- **2 attempts by telephone or email (if possible); then**
- **If telephone/email contacts are unsuccessful, 2 attempts must be made by certified letter or by appropriate local process.**

Where communication has been made by phone, this should be documented in the subject source notes.

The Investigator or designee must explain to each subject, before enrollment into the study, that for evaluation of study results, the subject's protected health information obtained during the study may be shared **with the study Sponsor, regulatory agencies, and IRB/IEC/REB. It is the Investigator's (or designee's) responsibility to obtain written permission to use protected health information per country-specific regulations, such as the Health Insurance Portability and Accountability Act (HIPAA) in the US, from each subject. If permission to use protected**



health information is withdrawn, it is the Investigator's responsibility to obtain a written request, to ensure that no further data will be collected from the subject and the subject will be removed from the study.

#### 9.3.3.1 Study Safety Evaluation Criteria

If any of the following events occur in a subject in the study who has received BMN 270 infusion, an urgent evaluation by the DMC will be required and further enrollment into the trial will be temporarily put on hold if recommended by the DMC per Section 9.1.

1. **Liver dysfunction (criteria do not apply to ALT elevations with an extra-hepatic etiology):**
  - ALT > 5x ULN, for more than 2 weeks
  - ALT > 3x ULN and (total bilirubin > 2x ULN or INR >1.5)
  - ALT > 3x ULN with signs and symptoms of liver dysfunction
2. **The occurrence of Grade 4 or Grade 5 adverse events assessed as related to study drug (events of liver dysfunction are defined above).**
3. The occurrence of an AE of hepatic failure.
4. The detection of high-titer neutralizing antibodies (>5 BU) to hFVIII following BMN 270 infusion in two subjects.
5. **The occurrence of any cancer (except non-melanoma skin cancer) at any point after BMN 270 infusion.**
6. **The occurrence of a thromboembolic event with FVIII activity > 150 IU/dL in one subject.**

If any of the following events occurs in a subject in the study who has received BMN 270 infusion, an urgent evaluation by the DMC will be required. Further enrollment into the trial will continue while DMC evaluation is ongoing, unless deemed otherwise by the DMC:

1. The detection of high-titer neutralizing antibodies (>5 BU) to hFVIII following BMN 270 infusion in one subject.
2. Occurrence of a thromboembolic event in one subject.

#### 9.3.4 Subject Identification and Replacement of Subjects

**Each subject will be assigned a unique subject identifier. This unique identifier will be on all eCRF pages.** In legal jurisdictions where use of initials is not permitted, a substitute identifier will be used.

Subjects who withdraw from the study after receiving BMN 270 will not be replaced.

### 9.3.5 Duration of Subject Participation

The duration of participation for each subject will be approximately 264 weeks. This includes 4 weeks of screening, 1 day of BMN 270 infusion, 52 weeks of Post-Infusion Follow-Up, and 208 weeks of Long-Term Follow-Up.

## 9.4 Treatments

### 9.4.1 Treatments Administered

BioMarin and/or its designee will provide the study site with a supply of IP sufficient for the completion of the study. BioMarin is responsible for shipping study drug to clinical sites.

### 9.4.2 Identity of Investigational Product

#### 9.4.2.1 Product Characteristics and Labeling

BMN 270 is a sterile, clear, colorless-to-pale yellow solution for IV infusion and is supplied in a 10 mL Crystal Zenith® (CZ) vial. Each vial contains 8.5 mL (extractable volume 8 mL) of AAV5-hFVIII-SQ at a concentration of 2E13 vector genomes per mL in a pH 7.4 phosphate buffer.

The study drug is labelled according to the particulars approved by the relevant regulatory agencies.

#### 9.4.3 Storage

At the study site, all IP must be stored under the conditions specified in the Pharmacy Manual in a secure area accessible only to the designated pharmacists and clinical site personnel. All IP must be stored and inventoried and the inventories must be carefully and accurately documented according to applicable state, federal and local regulations, ICH GCP, and study procedures.

#### 9.4.4 Directions for Administration

On the day of infusion, the subject will come to the infusion site, where a physical examination will be performed by the Investigator or designee. If the subject is found to have an active acute illness at the time of planned infusion, then the infusion should be deferred **until the illness has resolved; screening procedures may require repetition if outside the specified window.** An IV catheter or butterfly needle will be inserted into a suitable **peripheral vein (eg, the median cubital vein) and flushed with saline.** FVIII replacement therapy will not be given since venipuncture is a minimally invasive procedure in these individuals under ordinary conditions.

BMN 270 will be prepared and infused as a pure solution over a dose-dependent time. **Prepared drug will be kept at room temperature prior to administration. An electric syringe pump will be used to infuse through an in-line, low protein binding 0.22 micron filter. BMN 270 will be infused through the catheter using an appropriate infusion pump at an initial rate of 1 mL/min. The infusion rate should be increased every 30 minutes by 1 mL/min up to a maximum of 4 mL/min, provided that the subject's clinical condition permits such an increase. Of note, the IP has been shown to be stable at room temperature for 7.5 hours following completion of product thaw. Vital signs (pulse, blood pressure, respiration rate and temperature) should be monitored at 15 minute ( $\pm 5$  minutes) intervals throughout the time period of the infusion.**

**As with any infused biological product, there is a potential risk of acute, systemic hypersensitivity reactions (including anaphylaxis) with BMN 270. Dosing will be administered at a qualified infusion site, with appropriate resuscitation equipment and medication available and easily accessible.**

Clinical staff administering BMN 270 should be trained appropriately in recognizing and managing the signs and symptoms associated with potential hypersensitivity, anaphylactic, and anaphylactoid reactions. Additionally, the Investigator should be familiar with **Sampson's criteria for defining anaphylaxis (Sampson 2006; Appendix 1).**

Should symptoms of potential hypersensitivity occur, the infusion may be slowed or halted at the Investigator's discretion, with consideration of the subject's clinical condition. If the infusion is halted, it should only be restarted if the Investigator considers it safe and appropriate to do so. Antihistamines, anti-pyretic, and/or corticosteroid administration is permitted prior to restarting an interrupted infusion by an infusion-related reaction. **At the restart, the infusion rate may be adjusted (ie, to a slower rate [minimum of 1 mL/min], with the rate increased every 30 minutes by 1 mL/min up to a maximum rate of 4 mL/min, if the subject's clinical condition permits such an increase) with careful monitoring of the subject.**

In case of hypersensitivity or adverse drug reaction, safety assessment, including physical examination and vital signs, will be done and additional blood samples will be collected **within 1 hour of the hypersensitivity reaction (eg, tryptase, C3, C3a, C4, C5, C5a, and cytokine bead array, as well as possible additional exploratory testing) and samples for IgE and cytokine bead array (and possible additional exploratory testing) between 8-24 hours after the reaction, if possible. In addition, a blood sample should be taken 1 week after the hypersensitivity reaction for assessment of the cytokine bead array. In-patient observation can be extended and additional blood samples can be collected if deemed necessary at the discretion of the Investigator and Medical Monitor.**

Following completion of the infusion, vital signs will be **monitored hourly ( $\pm$  5 minutes)**. If the vital **signs are stable the catheter will be removed 8 hours after the infusion**.

Hemostasis at the puncture site will be established by applying pressure according to standard protocol for infusing FVIII concentrates. Subjects will remain in the clinic for at **least 8** hours to observe for any immediate toxicity of the **procedure; in-patient observation can be extended beyond 8 hours if needed per Investigator discretion, or the subject may** transfer to a separate facility based on the evaluation and judgment of the Principal Investigator after consultation with the Medical Monitor.

Prior to discharging subjects from the clinic, the Investigator or designee should instruct **subjects how to recognize signs and symptoms of potential (delayed) hypersensitivity reactions and anaphylaxis, and to contact a medical practitioner or seek emergency care in** case of such an event.

#### 9.4.5 Method of Assigning Subjects to Treatment Groups

**Subjects who meet all eligibility criteria (refer to Section 9.3.1 and Section 9.3.2) may be enrolled into the study. Approval by the Medical Monitor will be required** prior to enrollment of each study subject. Upon their enrollment into the study, **subjects will be assigned a unique subject number.**

**Approximately 130 subjects will be enrolled at 6E13 vg/kg.**

#### 9.4.6 Selection of Dose Used in the Study

Data from an ongoing first in **human study (Clinical Study 270-201) indicates that following single escalated doses of BMN 270 (6E12, 2E13, 4E13, 6E13 vg/kg), dose-related increases** in FVIII activity were observed, with concurrent improvements in bleeding episodes and exogenous FVIII **utilization, particularly at the 4E13 and 6E13 vg/kg dose levels. At all dose** levels, BMN 270 is considered to be well-tolerated with mild increases in ALT as the most common adverse event. Please refer to the IB for detailed efficacy and safety data.

In order to further evaluate the dose-response relationship of BMN 270, subjects will be **enrolled at a dose of 6E13 vg/kg. This dose is expected to be safe and effective based on** clinical experience to date in 270-201. **The DMC will review emerging safety and efficacy data and may recommend that a different dose (not to exceed 6E13 vg/kg) be administered. In such a case, up to 130 additional subjects may be enrolled at the new dose.**

#### 9.4.7 Blinding

This is an open-label study.

In order to minimize bias and to preserve the scientific and business integrity of the single-arm and open-label study, a data access plan (DAP) has been implemented.

This document provides guidelines for accessing post-treatment study data and applies to study team members, including personnel from within BioMarin, from external vendors and service providers, from the DMC, and from study sites. Role-based access control to study data, both individual patient-level data values as well as aggregated summaries of longitudinal data in an individual patient or across multiple patients, has been implemented to minimize potential bias and achieve appropriately controlled decision-making, while preserving operational efficiency. It is enforced by the DAP that individuals who are designated to have knowledge of the key efficacy variables (FVIII activity, FVIII usage, and bleeding counts) will not make or influence decisions that would alter the study design or conduct, or the collection or analysis of the key efficacy variables so as to bias the studies' key efficacy results.

#### 9.4.8 Prior and Concomitant Medications

All prescription and over-the-counter medications (including dietary and herbal supplements) taken by a subject for 30 days before Screening will be recorded on the designated eCRF.

The Investigator may prescribe additional medications, deemed necessary to provide adequate prophylactic or supportive care, during the study, as long as the prescribed medication is not prohibited by the protocol. In the event of an emergency, any needed medications may be prescribed without prior approval, but the Medical Monitor must be notified of the use of any contraindicated medications immediately thereafter. Any concomitant medications added or discontinued during the study should be recorded on the eCRF. Medications should, whenever possible, not be recorded in the electronic database with a frequency of PRN.

The following medications are prohibited starting 30 days before Screening and through the end of the study, and the Sponsor must be notified if a subject receives any of these during the study:

- Any investigational therapy other than BMN 270
- Emicizumab
- Fitusiran
- Concizumab
- Efavirenz

The following medications should be avoided, starting 30 days prior to and for at least **52 weeks after BMN 270 infusion and minimized** throughout the remaining duration of the study.

- Alcohol
- Herbal and natural remedies and dietary supplements
- Medications which may be hepatotoxic, including isotretinoin and **dextroamphetamine/amphetamine**
- Medications which may reduce or increase the plasma concentration of corticosteroids

Subjects should be counseled to avoid starting potentially hepatotoxic therapies and to inform the Investigator of any new medications prescribed by other physicians. Investigators should carefully consider both the mechanism of action and potential hepatotoxicity of any new medication prior to initiation. If a potentially concerning new medication is started, **Investigators should closely monitor both FVIII activity and ALT levels (eg, weekly to every 2 weeks for the first month) in order to determine if any detrimental effects on the efficacy or safety of BMN 270 have occurred. If co-medications are required during the course of the study, where possible, please check the National Center for Biotechnology Information LiverTox website for potential hepatotoxicity issues prior to prescribing (NCBI 2020).**

**Vaccines should also be avoided during this period, but in particular during the first 26 weeks unless clinically indicated.**

Administration of SARS-CoV-2 vaccine after BMN 270 infusion may occur after consultation between Investigator and Medical Monitor. Investigators should use clinical **judgment, taking into consideration local factors, individual risk factors, and the benefit/risk** related to timing of vaccine administration.

The following medications should be avoided during oral corticosteroid therapy:

- Vaccines
- NSAIDs

#### 9.4.8.1 Concomitant Hemophilia Treatments

Subjects on prophylactic FVIII therapy will discontinue their regular treatment regimen **starting 4 weeks after the day of infusion and switch to an “episodic” schedule. FVIII replacement therapy can always be taken as needed by the subject for treatment of an acute bleeding episode; the subject must carefully record his treatment** and bleeding episodes in his



diary. Prophylactic FVIII use can be used on a case-by-case basis and in consultation with **the Medical Monitor to prevent bleeding in extenuating circumstances (eg, peri-operative).**

In addition, information on FVIII usage and bleeding episodes by medical history must be **well-documented and available and will be collected from subjects for the 12-month period** immediately preceding study enrollment. Further information on the details that should be provided as part of the subject's well-documented medical and FVIII usage history are provided in the On Site File Binder.

In order to enable rigorous comparisons of pre-study versus on-study FVIII usage and bleeding episodes, the Medical Monitor will review each screened patient's prior bleed and hemophilia medication logs to determine if they are of "high-quality". **Elements that will be assessed to judge the quality of such historical data may include, but are not limited to, the following:**

- **Date, type (eg, joint, muscle, other), location of bleeds**
- **Date, name, dose (calculated in IU/kg), and reason for use (eg, usual prophylaxis, one-time prophylaxis, treatment for bleed, surgery) of hemophilia medications.**

#### **9.4.8.2 Reactive Glucocorticoid Treatment and/or Immunosuppressive Agent Treatment of Elevated Hepatic Transaminases**

Refer to corticosteroid prescription guidelines for recommended monitoring for, and management of, potential side effects of corticosteroids, including guidance on medications that should be avoided during corticosteroid treatment.

**Reactive oral corticosteroids (prednisone or converted equivalent) should be initiated when either of the following occurs post-BMN 270 infusion in any subject and after consultation with the Medical Monitor (or their designee):**

- **ALT > ULN or  $\geq 1.5x$  baseline value in 2 consecutive assessments within 72 hours and alternative etiologies have been ruled out, or ALT  $\geq 3x$  ULN in 2 consecutive assessments within 48 hours (refer to [Table 9.4.8.2.1](#))**
  - Whenever possible, a confirmatory lab draw for ALT should be performed, along with FVIII activity, prior to initiating reactive oral corticosteroids.
  - Corticosteroids may be delayed if elevations in ALT are clearly not related **to BMN 270 (eg, elevated ALT with concurrent increase in CPK due to intensive exercise), although this should be discussed with the Medical Monitor (in particular for elevations occurring more than 52 weeks after BMN 270 dosing).**

- Alternative immunosuppressive agents may also be considered for use on a case-by-case basis and following consultation with the Medical Monitor (**eg, if prolonged corticosteroid use is contraindicated**).

**Unless otherwise indicated, reactive corticosteroid treatment should be initiated at a dose of 60 mg/day. If the ALT level remains stable or declines after 2 weeks, consider gradual taper of corticosteroids: 40 mg/day for 3 weeks, 30 mg/day for 1 week, 20 mg/day for 1 week and 10 mg/day for 1 week.** Should a scenario arise in which differences from the minimum recommended dose and/or duration of reactive corticosteroids may be clinically indicated, a discussion should take place between the Investigator and Medical Monitor regarding corticosteroid dose adjustments. Management of ALT elevations with reactive corticosteroids, including tapering of doses and managing worsening and/or recurrent ALT elevations, should be guided by the following ([Table 9.4.8.2.1](#)):



Table 9.4.8.2.1: Management of ALT Elevations with Reactive Corticosteroids

|  |   |
|--|---|
| <p>ALT <math>\geq</math> 1.5x<br/>Baseline or &gt; ULN</p> | <ul style="list-style-type: none"> <li>• Repeat LTs and FVIII <b>within 24-72 hours</b></li> <li>• Continue to monitor LTs until ALT is stable or not increasing</li> <li>• <b>Investigate for alternative etiologies (eg, concomitant medications, viral or autoimmune hepatitis, alcohol use, recreational drug use, special diets, strenuous exercise, prior and/or concurrent illnesses, exposure to environmental and/or industrial chemicals, etc.)</b></li> <li>• If no alternative etiology is found, initiate reactive corticosteroids with the <b>following tapering schedule: 60 mg x 2 weeks; 40 mg x 3 weeks; 30 mg x 1 week; 20 mg x 1 week; 10 mg x 1 week upon consultation with the Medical Monitor</b></li> <li>• <b>Consider evaluation with additional liver tests (including but not limited to ALT, AST, bilirubin, and alkaline phosphatase)</b></li> <li>• Consider obtaining other possibly relevant laboratory evaluations (<b>albumin, PT/INR, CRP, etc.</b>)</li> <li>• Consider obtaining complete blood count with differential to assess for eosinophilia</li> <li>• Consider obtaining PBMC, C3, C3a, Bb, and sC5b-9 <b>to evaluate potential immune response (prior to starting reactive oral corticosteroids)</b></li> <li>• Continue to taper as long as subject's ALT is not increasing. Decisions regarding regimen modification may be made based upon Investigator judgement and discussion with the Medical Monitor</li> <li>• <b>For any ALT elevations that begin after 52 weeks on study, please</b> consult the Medical Monitor prior to initiating corticosteroids unless there is an imminent safety concern</li> </ul> |
| <p>Worsening ALT</p>                                       | <p><b>If after 2 weeks ALT levels have worsened with corticosteroid dose of 60 mg/day, the following is recommended:</b></p> <ul style="list-style-type: none"> <li>• Investigate for alternative etiologies including labs noted above, if not <b>previously checked</b></li> <li>• <b>Increase corticosteroid dose up to a maximum of 1.2 mg/kg for no more than 2 weeks</b></li> <li>• For subjects who are refractory to the maximum dose of corticosteroids, or intolerant to use of corticosteroids, consider use of alternative <b>immunosuppressants (tacrolimus or mycophenolate)</b></li> <li>• <b>Consider gastroenterology and/or hepatology consult, abdominal workup, imaging (including MRI or ultrasound), and/or liver biopsy as appropriate</b></li> </ul> <p>Any concerns should be discussed between the Investigator and the Medical Monitor</p>   |
| <p>Recurrent ALT elevations</p>                            | <p><b>If the subject has recurrent ALT elevations (<math>\geq</math> 1.5x Baseline or &gt; ULN) and there are no safety concerns, the decision regarding management may be made at the discretion of the Investigator after discussion with the Medical Monitor</b></p>   |

**For any scenarios that are not accounted for in the above table, a discussion should take place between the Investigator and Medical Monitor regarding corticosteroid dose adjustments.**

When ruling out alternative viral or autoimmune hepatitis as part of the elevated ALT workup, the following tests should be performed (Table 9.4.8.2.2):

**Table 9.4.8.2.2: Viral and Autoimmune Hepatitis Testing**

| <b>Viral Hepatitis Workup Testing</b>       | <b>Autoimmune Hepatitis Workup Testing</b> |
|---|--|
| Hepatitis A                                 | Smooth muscle antibody                     |
| Hepatitis B                                 | Mitochondrial antibody                     |
| Hepatitis C                                 | <b>Liver/kidney microsomal antibodies</b>  |
| Hepatitis E                                 | <b>Antinuclear antibody (ANA) HEP-2</b>    |
| <b>Cytomegalovirus (CMV)</b>                |  |
| <b>Epstein-Barr virus (EBV)</b>             |  |
| <b>Herpes simplex virus (HSV) 1 &amp; 2</b> |  |

After discontinuation of reactive oral corticosteroids, labs for ALT and FVIII levels will be **measured once a week for 4 weeks to ensure stability in values.**

Following completion of reactive oral **corticosteroids, if ALT elevation (eg, > ULN or  $\geq 1.5x$  baseline value) is reported, corticosteroid management decisions will be based on discussions between the Investigator and Medical Monitor. Modification of the corticosteroid regimen may take into consideration possible confounders for the ALT elevation and impact on FVIII expression.**

Management and monitoring of reactions to corticosteroids should be determined by the Investigator's clinical judgment in consultation with the Sponsor's Medical Monitor. This includes the contraindicated use of NSAIDs during corticosteroid treatment and specific **monitoring not already covered by the schedule of events. The use of COX-2 inhibitors, while not contraindicated during corticosteroid treatment, should be limited, if possible.** Practical management to prevent complications related to oral corticosteroid therapy may be **undertaken at the discretion of the Investigator (eg, evaluation of glucose intolerance, hyperlipidemia etc.). Alternative, non-steroidal systemic immunosuppressive agents may be used, following a discussion between the Investigator and the Medical Monitor, should corticosteroid use be deemed by an Investigator to be clinically ineffective, not tolerated, and/or contraindicated. Hepatitis B status and HCV viral load will be rechecked 6 weeks after the start of oral corticosteroid/immunosuppressive agent treatment and then 1 week and 13 weeks after the completion of oral corticosteroid/immunosuppressive agent treatment in subjects with a history of hepatitis B or hepatitis C. All adverse events (including any adverse events suspected to be caused by or related to corticosteroid/immunosuppressive agent use) should be reported as outlined in Section 10 of the protocol.**

Subjects on corticosteroids should receive appropriate counselling and support regarding side effects from the Investigator or the treating institution (eg, listings of side effects and when to notify carers, wallet card for emergencies if on steroids, etc.). Additional management, including the co-prescription of additional medications to prevent complications related to corticosteroid therapy, may be undertaken at the discretion of the investigator, including, but not limited to, prophylaxis against the occurrence of gastric ulcers, osteoporosis, and infections. The above guidance should also be followed in the event that an alternative immunosuppressive agent is used, as applicable.

#### 9.4.8.3 Monitoring of HIV-Positive Subjects

HIV-positive subjects who have previously enrolled in 270-301 should continue anti-retroviral therapy (ART) as prescribed and follow routine monitoring of CD4 count and viral load (US Dept Health Human Services 2019). No alterations in the monitoring are indicated for enrolled immunocompetent HIV-positive subjects who receive corticosteroids as part of their enrollment in 270-301.

#### 9.4.9 Treatment Compliance

Study drug will be administered to subjects at the study site and/or the dosing facility by a qualified health care professional. The quantity dispensed, returned, used, lost, etc. must be recorded on a dispensing log. Sites will be instructed to return or destroy all used and unused study drug containers.

#### 9.5 Investigational Product Accountability

The Investigator or designee is responsible for maintaining accurate records (including dates and quantities) of IP(s) received and IP lost or accidentally or deliberately destroyed.

The Investigator or designee must retain all unused or expired study supplies until the study monitor (on-site CRA) has confirmed the accountability data, if allowed by local SOPs.

##### 9.5.1 Return and Disposition of Clinical Supplies

Unused study drug must be kept in a secure location for accountability and reconciliation by the study monitor. The Investigator or designee must provide an explanation for any destroyed or missing study drug or study materials (or must be referenced in their institution SOPs).

Unused study drug may be destroyed on site, per the site's standard operating procedures, but only after BioMarin has granted approval for drug destruction. The monitor must account for all study drug in a formal reconciliation process prior to study drug destruction. All study drug destroyed on site must be documented. Documentation must be provided to BioMarin or

designee and retained in the Investigator study files. If a site is unable to destroy study drug **appropriately, the site can return unused study drug to BioMarin upon request. The return of study drug or study drug materials must be accounted for on a study drug return form provided by BioMarin.**

All study drug and related materials should be stored, inventoried, reconciled, and destroyed or returned according to applicable state and federal regulations and study procedures. For additional information, please refer to the Pharmacy Manual.

## 9.6 Dietary or Other Protocol Restrictions

There are no dietary or other protocol restrictions for this study. Alcohol should be avoided for the first 52 **weeks of the study, and particularly within 48 hours prior to lab work.** Alcohol use should be minimized throughout the remaining duration of the study.

Subjects should be advised to abstain from any blood or sperm donation after BMN 270 infusion, until there is no further evidence of vector shedding from PCR analysis of samples. Subjects should also abstain from organ donation.

## 9.7 Safety and Efficacy Variables

### 9.7.1 Safety and Efficacy Measurements Assessed

**The Schedule of Events (Table 9.1.1 through Table 9.1.5) describes the timing of required evaluations.**

### 9.7.2 Primary Efficacy Variables

#### 9.7.2.1 FVIII Activity

The primary efficacy variable is change of the hFVIII activity, as measured by chromogenic **substrate assay, during Weeks 49-52** post-BMN 270 infusion from baseline. Each subject's **hFVIII activity during Weeks 49-52** is defined as the median of the values obtained during **this 4-week window. Values for FVIII activity will be excluded if obtained within 72** hours since the last infusion of exogenous FVIII protein concentrates.

If a subject has used FVIII within 72 hours of a measurement day, all efforts should be made to obtain FVIII activity measurements when a 72-hour interval without FVIII use is **achieved; The 72-hour wash-out period is only intended for subjects who have achieved FVIII  $\geq 5$  IU/dL at 16 weeks after BMN 270 infusion and who have not resumed FVIII replacement therapy.**

**Note that fluctuations in FVIII activity after gene therapy are common, and more frequent monitoring of FVIII activity levels is not needed in the absence of a concurrent or recent ALT elevation or upon consultation between the Investigator and the Medical Monitor.**

**Subjects who do not respond to BMN 270 treatment (ie treatment failure, manifesting as failure to achieve FVIII activity  $\geq$  5 IU/dL by Week 52 and inability to maintain independence from prophylactic FVIII replacement therapy due to joint bleeding episodes, in the judgment of the Investigator) may, at the Investigator's discretion and after discussion with the Medical Monitor or Sponsor-designated Data Monitor, follow an abbreviated visit schedule after Week 52 of the study by attending only the Q12W and End of Year visits during Years 2-5. Subjects who are not attending the Q4W/Q6W visits during Years 2-5 may receive a scheduled monthly follow-up telephone call from the site to ask about adverse events, concomitant medications, and bleeding events/FVIII replacement usage.**

Details on collecting FVIII activity samples are included in the Laboratory Manual.

### 9.7.3 Secondary Efficacy Variables

#### 9.7.3.1 Factor VIII Replacement Therapy/Bleeding Episodes

Secondary efficacy variables are:

- **Change of the annualized utilization (IU/kg) of exogenous FVIII replacement therapy in the efficacy evaluation period ("Week 5 to Last Visit") from the baseline utilization of exogenous FVIII replacement therapy.**
- **Change in the annualized number of bleeding episodes requiring exogenous FVIII replacement treatment in the efficacy evaluation period ("Week 5 to Last Visit") from the baseline ABR.**

**Subjects must have high quality documented historical data available concerning previous bleeding episodes and exogenous FVIII usage over the previous 12 months in order to be eligible to enroll in the study. During the study, subjects will be asked at each study visit to report the use of factor replacement therapy and the number of bleeding episodes since the previous visit. This information will be captured on the subject's diary or other subject records. Subjects will be encouraged to discuss any bleeding episodes with the Investigator and attempt to objectively assess any reported bleeds through use of ultrasound or non-invasive imaging.**

Subjects are strongly encouraged to immediately consult Investigator for guidance regarding exogenous FVIII administration for suspected bleeds or bleeding episodes within the first 30 days post BMN 270 infusion.

In subjects who experience recurrent bleeding episodes, the Investigator and Medical Monitor will discuss whether to resume prior FVIII prophylaxis.

#### 9.7.4 Tertiary Efficacy Variables

##### 9.7.4.1 Patient-Reported Outcome (PRO) Measures

The Haemo-QoL-A questionnaire is a validated hemophilia-specific health-related quality of life questionnaire for adults (Rentz 2008). It consists of 41 questions covering six domains (Physical Functioning, Role Functioning, Worry, Consequences of Bleeding, Emotional Impact and Treatment Concerns). Items are answered on a 6-point Likert-type scale, ranging from 0 (None of the time) to 5 (All of the time). Higher scores mean better health-related quality of life or less impairment for a particular subscale (Haemo-QoL Study Group 2017). Details regarding the Haemo-QoL-A assessment will be included in the On Site File Binder.

The EQ-5D-5L instrument is a self-reported questionnaire designed to measure general health status (The EuroQol Group 1990; Brooks 1996). The EQ-5D-5L is composed of 2-parts: a descriptive system that assesses 5 levels of perceived problems (mobility, self-care, usual activities, pain/discomfort, and anxiety/depression) in 5 dimensions and the EQ visual analogue scale (EQ VAS) assessment for overall health. A sample copy of the EQ-5D-5L and additional information are provided in the On Site File Binder.

The Haemophilia Activities List (HAL) measures the impact of hemophilia on self-perceived functional abilities in adults (Van Genderen 2006). The instrument consists of multiple domains including lying/sitting/kneeling/standing, leg and arm function, use of transportation, self-care, household tasks, and leisure activities where subjects are asked to rate their level of difficulty with activities of daily living on a 6-point Likert-type scale from 1 (Impossible) to 6 (Never). For some items, subjects are given the choice to answer 'Not applicable'. A sample copy of the HAL and additional information are provided in the On Site File Binder.

The Work Productivity and Activity Impairment plus Classroom Impairment Questions: Hemophilia Specific (WPAI+CIQ:HS) instrument is designed to measure the effect of disease symptom severity on work productivity and classroom productivity (if applicable) (Recht 2014). The WPAI+CIQ:HS questionnaire yields scores related to work/classroom absenteeism, reduced on-the-job effectiveness, overall work/classroom impairment, and activity impairment. WPAI+CIQ:HS outcomes are expressed as impairment percentages, with higher numbers indicating greater impairment and less productivity (Reilly 2002). A sample copy of the WPAI+CIQ:HS and additional information are provided in the On Site File Binder.



The Patient Reported Outcomes, Burdens, and Experiences (PROBE) questionnaire is designed to investigate and directly probe patient perspectives on outcomes they deem relevant to their life and care. PROBE aims to develop a new global tool to enhance the direct patient-voice in health care decision-making (Chai-Adisaksopha 2017). PROBE data collected in 270-301 will be shared with the Patient Outcomes Research Group (PORG) in order to facilitate validation of the tool; subjects may opt out of having their data used for this purpose. A sample copy of the PROBE questionnaire and additional information are provided in the On Site File Binder.

### 9.7.5 Immunogenicity

Immunogenicity assays will be performed on plasma and PBMCs. The assays will include detection of anti-AAV5 capsid and anti-FVIII total antibodies, as well as determination of neutralizing antibodies against FVIII (FVIII inhibitors) and against the AAV5 capsid (Transduction Inhibitors, TI). FVIII Inhibitors will be assessed using the Bethesda assay with Nijmegen modification. Any abnormality of the liver parameters will lead to a retrospective immunogenicity assessment to evaluate FVIII- and capsid-specific cellular immunogenicity. FVIII- and capsid-specific cellular immunity will be assessed by stimulated cytokine secretion using an ELISpot assay performed on collected PBMCs.

### 9.7.6 Pharmacodynamics

The FVIII protein concentration and activity level as measured by a validated immunoassay and by a validated FVIII activity assay, respectively, will be used for plasma profiles; FVIII protein and activity will be used to determine PD parameters.

### 9.7.7 Exploratory Assessments

Blood samples will be collected from subjects at the time points indicated in Table 9.1.1, Table 9.1.2, Table 9.1.3, Table 9.1.4, and Table 9.1.5 to evaluate biochemical, molecular, cellular, and genetic/genomic aspects relevant to hemophilia A, coagulation, and/or AAV gene transfer, and to develop assays used for these evaluations. Subjects may choose to opt out of the exploratory genetic/genomic research being done to study or try to discover genes that are not yet known to be associated with hemophilia A.

All biomarker samples collected in this study may be used for exploratory biomarker research, including evaluation of additional biomarkers not specifically listed in the protocol. In addition, samples collected for other purposes in this study may be used for exploratory research once testing for the primary purpose has been completed.

### 9.7.7.1 Optional Liver Biopsy

Subjects electing to undergo an optional liver biopsy are required to consent to the procedure and collection of tissue in the study ICF. The analysis of the optional liver biopsy is considered exploratory. Subject who elect to proceed will have a liver biopsy performed during Year 1 post-infusion, at or around Week 52, and/or during Years 2-5. Additional liver biopsies at times deemed to be clinically relevant (eg, decreasing FVIII at a time of increased ALT) may be pursued at any time during Years 2-5. Subjects will be asked to consent to the procedure for each liver biopsy performed during the study.

Subjects who consent to the procedure will have a liver biopsy via either transjugular or percutaneous (ultrasound-guided) route, according to the standard procedures of the institution. Two tissue cores will be harvested in the context of the optional liver biopsy. Subjects will be required to observe an 8-hour fasting period before the procedure.

Within 24 hours prior to the biopsy being performed, subjects must have a documented FVIII activity level of  $\geq 50$  IU/dL (or higher, depending on local guidelines and/or investigator discretion). FVIII activity levels for this purpose should be assessed at the local laboratory within 7 days before the biopsy and again on the day the biopsy, prior to the procedure. As needed, subjects may be treated with additional exogenous FVIII replacement products in order to increase their FVIII activity levels to an appropriate level, under the supervision/instruction of the investigator, to ensure the safety of the subject during the procedure. This exogenous FVIII usage (if performed) should be recorded in the eCRF FVIII infusion pages under the category "Surgery/Procedure".

Details on required procedures for the optional liver biopsy are outlined in [Table 9.1.7](#). Subjects consenting to participate to the optional liver biopsy will undergo pre-biopsy assessments within 28 days before the procedure, as follows:

- Physical examination
- Hematology, coagulation, chemistry assessments
- Liver tests
- Liver ultrasound (subject should fast at least 8 hours prior to ultrasound)
- FibroScan

Subjects consenting to participate to the optional liver biopsy will undergo pre-biopsy assessments within 7 days before the procedure, as follows:

- Local FVIII activity level assessment
- Pre-biopsy consultation (with hepatologist and/or radiologist)



On the day of the biopsy, brief physical examination and liver and blood tests should be **performed before the procedure (including hematology, coagulation, and chemistry)**. FVIII activity assessment should also be performed to ensure the subject has sufficient FVIII activity to protect against procedure-**related bleeding (as discussed above)**. **LT assessment** and a whole blood draw for PBMC collection should be performed on the biopsy day or **± 1 week from the biopsy day**.

The optional liver biopsy should be performed in the morning if feasible, and the biopsy procedure and follow-up care should be done according to the local standard of care. Additional details for handling the biopsy specimens are provided in the Laboratory Manual.

Following completion of the biopsy, the subject should remain under observation in the clinic **for at least 4-6 hours**. **Overnight post-procedure** observation may be done at the investigator's **discretion and/or according to local guidelines**.

Clinically significant findings reported from the histopathological analysis of the biopsy sample **are subject to AE reporting (Section 10)**. **Such findings should be further assessed** and followed as clinically appropriate to manage the subject's medical care. A hepatologist **and/or other specialist clinicians should be consulted if required**. **In the event that fibrotic changes are observed on the biopsy sample, additional liver ultrasound, FibroScan and/or Enhanced Liver Fibrosis (ELF) testing (as regionally available and/or approved by HA) may be considered at the discretion of the investigator and/or hepatologist**.

### 9.7.8 Safety Variables

Safety in this study will be determined from evaluation of AEs, clinical laboratory assessments with a particular attention to the liver function, vital signs assessments, physical examinations, and immunogenicity.

#### 9.7.8.1 Adverse Events

The determination, evaluation and reporting of AEs will be performed as outlined in Section [10](#).

#### 9.7.8.2 Clinical Laboratory Assessments

The scheduled clinical laboratory tests are listed in [Table 9.7.8.2.1](#). Refer to the On Site File Binder for instructions on obtaining and shipping samples.

Any abnormal test results determined to be clinically significant by the Investigator should be repeated **(at the Investigator's discretion) until: (1) the cause of the abnormality is determined; (2) the value returns to baseline or to within normal limits; or (3) the Investigator determines that the abnormal value is no longer clinically significant**.

All abnormal clinical laboratory results should be initialed and dated by an Investigator, along with a comment regarding whether or not the result is clinically significant. Each clinically significant laboratory result should be recorded as an adverse event.

The **diagnosis, if known, associated with abnormalities in clinical laboratory tests that are considered clinically significant by the Investigator** will be recorded on the AE eCRF.

**Table 9.7.8.2.1: Clinical Laboratory Tests**

| Blood Chemistry   | Hematology                       | Urine Tests         | Coagulation Screen including: |
|-------------------|----------------------------------|---------------------|-------------------------------|
| Albumin           | Hemoglobin                       | Appearance          | APTT                          |
| <b>BUN</b>        | Hematocrit                       | Color               | <b>PT/INR</b>                 |
| Calcium           | WBC count                        | pH                  | TT                            |
| Chloride          | RBC count                        | Specific gravity    |                               |
| Total cholesterol | Platelet count                   | <b>Ketones</b>      |                               |
| <b>CPK</b>        | Differential cell count          | Protein             |                               |
| Creatinine        | <b>RBC indices (MCV and MCH)</b> | Glucose             |                               |
| CRP               |                                  | Bilirubin           |                               |
| Glucose           |                                  | Nitrite             | <b>Other Tests</b>            |
| Phosphorus        |                                  | <b>Urobilinogen</b> | ABO blood typing*             |
| Potassium         |                                  | Hemoglobin          |                               |
| Total protein     |                                  |                     |                               |
| Sodium            |                                  |                     |                               |
| <b>Uric Acid</b>  |                                  |                     |                               |

**BUN, blood urea nitrogen; CPK, creatinine phosphokinase; CRP, C-reactive protein; PT, prothrombin time; APTT, activated partial thromboplastin time; RBC, red blood cell; WBC, white blood cell; TT, thrombin time; INR, international normalized ratio; MCV, mean corpuscular volume; MCH, mean corpuscular hemoglobin.**

\*ABO blood typing assessment should be performed at Baseline, or at another regularly scheduled visit prior to the end of the subject's participation in the study.

In addition to scheduled clinical laboratory assessments, a fasting blood lipid panel **(including triglycerides, total cholesterol, HDL cholesterol, and LDL cholesterol) will be assessed at the BMN 270 infusion visit. Subjects will fast for at least 8 hours** prior to pre-infusion laboratory sampling on the day of the infusion visit.

In case of hypersensitivity or adverse drug reaction, safety assessment, including physical examination and vital signs, will be done and additional blood samples will be collected **within 1 hour of the hypersensitivity reaction (eg, tryptase, C3, C3a, C4, C5, C5a, and cytokine bead array, as well as possible additional exploratory testing) and samples for IgE**

and cytokine bead array (and possible additional exploratory testing) between 8-24 hours after the reaction. In addition, a blood sample should be taken 1 week after the hypersensitivity reaction for assessment of the cytokine bead array.

At applicable sites, certain study assessments designed in the Schedule of Events may be performed by a mobile nursing (MN) professional at the patient's home or another suitable location, such as their school or office, to improve access and convenience for patients participating in the study. The Sponsor may select a healthcare company that will be responsible for providing MN services for participating sites (the MN vendor). The MN vendor is responsible for ensuring that all MN professionals are licensed, qualified, and in good standing, as per applicable regulations, and that appropriate background checks have been performed. If the investigator at a participating site determines that MN services are appropriate for a patient and the patient gives written informed consent to participate in MN visits, the MN network will communicate with the patient and the patient's site.

For all subjects, MN visits will be allowed for the Q4W (during Year 2) and Q6W (during Years 3-5) visits; the Q12W visits and End of Year visits during Years 2-5 will not be performed by an MN professional but will be done at the study site. For subjects who have enrolled in 270-301 following participation in 270-902, MN visits may also be available during Year 1 at Weeks 5, 7, 9, 11, 13, 15, 17, 19, 21, 23, 25, 27, 29, 30, 31, 33, 34, 35, 38, 42, 46, and 50 (as indicated in the Schedule of Events). At visits not specifically designated for MN eligibility (ie, visits where the subject is intended to return to the site for assessment), MN services may be used if the subject is unable to attend the site to complete the study visit during the acceptable window for that visit, upon prior approval by the Medical Monitor and discussion between the Medical Monitor and Investigator.

In the event that neither a lab-only visit or MN visit can be conducted for a post-infusion visit, the site should telephone the subject to collect adverse event, concomitant medication, and diary data (bleeding events and FVIII usage), in the interest of monitoring subject safety and welfare.

### 9.7.8.3 Malignancies

Liver ultrasounds will be performed annually at each End of Year visit starting at Year 2 (Week 104) through the end of the study to screen for HCC. Additional liver ultrasounds may be performed between the End of Year visits at the discretion of the Investigator.

Any development of a malignancy (except non-melanoma skin cancers) during the course of the study will be considered an EOSI (refer to Section 10.2.1) and is subject to expedited reporting. In addition, it is recommended that genomic analyses be performed on any

**malignancy (except non-melanoma skin cancers) diagnosed during the course of the study.**

The study site will coordinate sending samples from the malignancy for genomic analyses, if available.

#### 9.7.8.4 Liver and Hepatitis Testing

Subjects will be screened for evidence of previous or active hepatitis B or hepatitis C **infection at Screening; hepatitis B screening should include HBsAg, HBsAb, and HBcAb.**

Subjects with documented results showing an absence of active hepatitis B or hepatitis C **infection (as measured by positive DNA for hepatitis B or positive RNA testing for hepatitis C) 30 days prior to providing signed informed consent do not need to repeat those tests during the screening period.**

Evidence of ongoing hepatitis B or hepatitis C infection is exclusionary. Subjects with a history of hepatitis B or hepatitis C infection prior to study entry will be tested for hepatitis B **and hepatitis C reactivation at Week 16. Subjects with a history of hepatitis B or hepatitis C will be asked for information about the treatments received as part of their medical history** assessment at Screening.

Subjects with a previous history of hepatitis B or hepatitis C who receive therapeutic oral corticosteroids **prior to Week 16 do not need to complete the Week 16 reactivation assessment; instead, they will be tested for hepatitis B and hepatitis C reactivation at the time points listed in Table 9.1.6.**

**A liver ultrasound and liver tests (LTs) during Screening will identify any significant hepatic dysfunction.**

**LTs will be monitored on a regular basis; at each time point, the following LTs should be assessed:**

Table 9.7.8.4.1: Liver Tests

| Liver Tests (LTs)    |                  |                 |     |
|----------------------|------------------|-----------------|-----|
| Alkaline Phosphatase | AST (SGOT)       | Total Bilirubin | LDH |
| ALT (SGPT)           | Direct Bilirubin | GGT             |     |

ALT, alanine aminotransferase; AST, aspartate aminotransferase; GGT, gamma glutamyltransferase; LDH, lactate dehydrogenase; SGOT, serum glutamic oxaloacetic transaminase; SGPT, serum glutamic-pyruvic transaminase

**Elevated ALT levels (above the upper limit of normal range) should be evaluate<sup>d</sup> according to the plan outlined in Table 9.4.8.2.1 (note that these evaluations may indicate additional testing of LTs and FVIII levels at unscheduled visits; these unscheduled laboratory tests may**

be completed by a mobile nursing professional at sites where the use of MN services has **been approved**).

#### 9.7.8.5 HIV Testing

HIV testing will be performed at Screening. Subjects with documented negative results within the last 30 days prior to screening do not need to be retested.

#### 9.7.8.6 Vital Signs, Physical Examinations and Other Observations Related to Safety

Vital signs will include seated systolic and diastolic blood pressure, heart rate, respiration rate, and temperature. Any clinically significant change in vital signs will be recorded as an AE.

Systolic blood pressure, diastolic blood pressure, heart rate, respiration rate, and temperature will be assessed at Screening, Baseline, and at the beginning of each visit during the **Post-Infusion Follow-Up and Long-Term Follow-Up periods. On the day of the BMN 270 Infusion, vital signs will be monitored prior to infusion, during the infusion every 15 minutes ( $\pm 5$  minutes), following the infusion hourly ( $\pm 5$  minutes) for at least 8 hours** during the subject's stay in the clinic. Any abnormal vital sign assessments should be repeated, and both values should be recorded in the eCRF.

**A complete physical examination is necessary during Screening/Baseline, at Week 26 and 52 and every 52 weeks thereafter; at other visits, brief physical examinations may be performed at the discretion of the Investigator based on the subject's clinical condition. Particular attention should be given to signs of bleeding, as well as assessing possible hemarthroses. During Year 1, at visits where the MN services are used or shortened lab draw-only visits are conducted at the sites, the physical examination and vital signs assessments indicated in the Schedule of Events will not be performed.**

A complete physical examination will **include general appearance (head, eyes, ears, nose, and throat), cardiovascular, dermatologic, lymphatic, respiratory, gastrointestinal, genitourinary, musculoskeletal, and neurologic systems.** The genitourinary examination may be deferred for **visits after Year 1 unless the subject has genitourinary-related complaints.**

A brief physical examination will include general appearance, cardiovascular, dermatologic, **respiratory, gastrointestinal, musculoskeletal, and neurologic assessments.**

Height will be recorded at Screening only. Weight will be recorded at Screening and then **every 4 weeks thereafter through Week 52, and at the second Q12W visit each year and at every End of Year visit during Years 2-5.**

### 9.7.8.7 Vector Shedding

During the Post-Infusion Follow-Up period, subjects will undergo testing of various bodily samples to look for evidence of vector shedding for possible viral transmission. Bodily fluids will be tested by polymerase chain reaction (PCR). Fluids tested will include:

- Blood
- Saliva
- Semen
- **Urine**
- Stool

Vector shedding will also be extensively studied in the present clinical trial, at the time points indicated in [Table 9.1.1](#), [Table 9.1.2](#), [Table 9.1.3](#), [Table 9.1.4](#), and [Table 9.1.5](#). Testing will continue until at least 3 consecutive results below the limit of detection are obtained. If a positive result is obtained in a matrix after 3 consecutive results below the limit of detection have already been recorded, testing in that matrix should restart and continue until an additional 3 consecutive results below the limit of detection have been obtained in order to confirm clearance.

**Testing of semen will continue at least through Week 12, even if 3 consecutive results** below the limit of detection have been recorded in that compartment prior to that time point.

Subjects who have not had 3 consecutive semen samples below the limit of detection by **Week 52 should continue to have PCR testing in semen every 4 weeks (during Year 2) and every 6 weeks (during Years 3-5) until 3 consecutive samples below the limit of detection are documented (or upon consultation between the Investigator and Medical Monitor).**

Subjects who meet the definition of treatment failure and wish to follow an abbreviated schedule (refer to [Section 12.7](#)) but who **have not cleared vector shedding from semen must still provide samples for assessment every 4 weeks (during Year 2) or every 6 weeks (during Years 3-5) until vector shedding has cleared. Such subjects may provide samples on the designated study visit dates either at the sites or through use of a MN professional.**

Samples may be fractionated prior to shedding analysis in order to better characterize the **presence, structure, and location of vector DNA and/or vector capsid within each matrix.** If needed, the fractionation may be performed with samples collected specifically for **shedding analysis (saliva, blood, semen, urine, stool).** Alternatively, the vector DNA characterization during shedding analysis may utilize already fractionated exploratory

samples obtained from the above biofluids, such as exploratory plasma samples, exploratory PBMC samples, and red blood **cells recovered during PBMC/plasma isolations.**

Fractionation of semen to collect purified sperm separately from non-sperm cells may be performed in parallel at any visit where semen samples are collected. The shedding analysis of a fractionated semen sample will only be performed if vector DNA was detected in the whole semen sample for the same visit. Fractionation of semen during shedding analysis may be stopped if purified sperm tested positive for vector DNA on at least three visits, or if purified sperm tested negative for vector DNA on at least three consecutive visits.

**Contraception use may need to be extended beyond 12 weeks in individual subjects based on observed vector shedding in semen. After 12 weeks, subjects may stop contraception use only if they have had 3 consecutive semen samples with viral vector DNA below the limit of detection (upon consultation between the Investigator and Medical Monitor).**

Details for sample collection and storage are provided in the Laboratory Manual.



## 10 REPORTING ADVERSE EVENTS

### 10.1 Safety Parameters and Definitions

Safety assessments will consist of monitoring and recording protocol-**defined AEs and SAEs**; measurement of protocol-**specified hematology, clinical chemistry, and urinalysis variables**; measurement of protocol-**specified vital signs; and other protocol-defined** events of special interest that are deemed critical to the safety evaluation of the study drug.

#### 10.1.1 Adverse Events

**For this protocol, an adverse event (AE) is any untoward medical occurrence in a subject, temporally associated with the use of study intervention, whether or not considered related to the study intervention.**

**An AE can therefore be any unfavorable and unintended sign (including an abnormal laboratory finding), symptom, or disease (new or exacerbated) temporally associated with the use of study intervention.**

Events meeting the AE definition include:

- Exacerbation of a chronic or intermittent pre-existing condition including either an **increase in frequency and/or intensity of the condition.**
- New conditions detected or diagnosed after study intervention administration even though it may have been present before the start of the study.
- **Signs, symptoms, or the clinical sequelae of a suspected drug-drug interaction.**

Events not meeting the AE definition include:

- Any clinically significant abnormal laboratory findings or other abnormal safety assessments which are associated with the underlying disease, unless judged by the investigator to be more severe than expected for the subject's condition.
- **The disease/disorder being studied or expected progression, signs, or symptoms of the disease/disorder being studied, unless more severe than expected for the subject's condition.**
- **Medical or surgical procedure (eg, endoscopy, appendectomy): the condition that leads to the procedure is the AE.**
- **Situations in which an untoward medical occurrence did not occur (social and/or convenience admission to a hospital).**
- Anticipated day-to-day fluctuations of pre-**existing disease(s) or condition(s)** present or detected at the start of the study that do not worsen.



### 10.1.1.1 Bleeding and Suspected Bleeding Events

All bleeding events and suspected bleeding events, regardless of the need for exogenous FVIII therapy as treatment, should be captured in subject diaries and recorded on the designated bleeding eCRF. Bleeding events and suspected bleeding events should not be reported as adverse events, with the following exception:

- All bleeding events and suspected bleeding events which meet one or more of the criteria **for being serious (refer to Section 10.2) should be reported as serious adverse events (whether or not they are bleeding events that are normal sequelae of hemophilia, and whether or not they required exogenous FVIII as treatment).**

### 10.2 Serious Adverse Events

**A serious adverse event (SAE) is any untoward medical occurrence that, at any dose:**

- Results in death
- Is life-threatening

*Note: Life-threatening refers to an event in which the subject was at risk of death at the time of the event. It does not refer to an event, which hypothetically might have caused death, if it were more severe.*

- **Requires inpatient hospitalization or prolongation of existing hospitalization**

**Note: In general, hospitalization signifies that the subject has been detained (usually involving at least an overnight stay) at the hospital or emergency ward for observation and/or treatment that would not have been appropriate in the physician's office or outpatient setting. If the investigational product preparation, infusion, and post-infusion observation period require transfer to an inpatient setting for completion, in the absence of an AE, this will not be considered an SAE.**

Complications that occur during hospitalization are AEs. If a complication prolongs hospitalization, the event is serious.

Hospitalization for elective treatment of a pre-existing condition that did not worsen from baseline is not considered an AE.

- Results in persistent or significant disability or incapacity
- Is a congenital anomaly or birth defect in the child or fetus of a subject exposed to IP prior to conception or during pregnancy
- Is an important medical event or reaction – that, based on medical judgment, may jeopardize the subject **or require medical/surgical intervention to prevent one of the other outcomes listed above (eg, anaphylaxis)**

### 10.2.1 Events of Special Interest (EOSI)

The following EOSI need to be reported to the Sponsor within 24 hours of site awareness, irrespective of seriousness, severity or causality:

- **Elevation of ALT > ULN or  $\geq 1.5x$  baseline value**, regardless of whether that elevation triggers an initiation or modification of oral corticosteroid treatment
- **Events potentially meeting the criteria for Hy's law (ALT or AST elevation  $\geq 3x$  ULN plus total bilirubin  $\geq 2x$  ULN)**
- Thromboembolic event
- **Systemic hypersensitivity, anaphylactic, or anaphylactoid reactions (refer to Appendix 1)**
- Development of **anti-FVIII inhibitory antibodies (inhibitors)**
- Any new diagnosis of **malignancy (except non-melanoma skin cancer)**

### 10.3 Methods and Timing for Capturing and Assessing Safety Parameters

#### 10.3.1 Adverse Event Reporting Period

The study AE reporting period is as follows:

- After informed consent but prior to initiation of study drug, only SAEs associated with any protocol-imposed interventions will be collected. AEs occurring during this time period should be recorded on the Medical History eCRF.
- After informed consent is obtained and following infusion of study drug, the reporting period for all non-serious AEs and SAEs begins and continues for approximately **5 years or until study discontinuation/termination, whichever is longer.**

The criteria for determining, and the reporting of SAEs is provided in Section 10.2.

#### 10.3.2 Eliciting Adverse Events

Care will be taken not to introduce bias when detecting AEs and/or SAEs. Open-ended and non-leading verbal questioning of the subject is the preferred method to inquire about AE occurrences. The Investigator will record all relevant AE/SAE/EOSI information in the subject's medical record and AE Case Report Form (eCRF).

#### 10.3.3 Assessment of Seriousness, Severity, and Causality

The Investigator responsible for the care of the subject or medically qualified designee will assess AEs for severity, relationship to study drug, and seriousness (refer to Section 10.2 for SAE definitions). These assessments must be made by a study clinician with the training and

authority to make a diagnosis (eg, MD/DO, physician’s assistant, nurse practitioner, or DDS).

### 10.3.3.1 Seriousness

The Investigator will assess if an AE should be classified as “serious” based on the seriousness criteria enumerated in Section 10.2. Seriousness serves as a guide for defining regulatory reporting obligations.

### 10.3.3.2 Severity

Severity (as in mild, moderate, or severe headache) is not equivalent to seriousness, which is based on subject/event outcome or action criteria usually associated with events that pose a threat to a subject’s life or functioning. The Investigator will determine the severity of each AE, SAE and EOSI using the NCI CTCAE v4.03. Adverse events that do not have a corresponding CTCAE term will be assessed according to the general guidelines for grading used in the CTCAE v4.03 as stated in Table 10.3.3.2.1.

Table 10.3.3.2.1: Adverse Event Grading (Severity) Scale

| Grade | Description  |
|-------|--|
| 1     | Mild: <b>asymptomatic or mild symptoms; clinical or diagnostic observations only; intervention not indicated</b>   |
| 2     | Moderate: <b>minimal, local or noninvasive intervention indicated; limiting age-appropriate instrumental activities of daily living (ADL)<sup>a</sup></b>                                |
| 3     | Severe or medically significant but not immediately life-threatening: hospitalization or <b>prolongation of hospitalization indicated; disabling; limiting self-care ADL<sup>b</sup></b> |
| 4     | <b>Life threatening consequences; urgent intervention indicated</b>  |
| 5     | Death related to AE  |

<sup>a</sup> Instrumental ADL refer to the following examples: preparing meals, shopping for groceries or clothes, using the telephone, managing money.

<sup>b</sup> Self-care ADL refer to the following examples: bathing, dressing and undressing, feeding oneself, using the toilet, **taking** medications, not bedridden.

### 10.3.3.3 Causality

The Investigator will determine the relationship of an AE to the study drug and/or corticosteroids and/or other immunosuppressant agents and will record it on the source documents and AE eCRF. To ensure consistency of causality assessments, Investigators should apply the guidance in Table 10.3.3.3.1.

Table 10.3.3.3.1: Causality Attribution Guidance

| Relationship | Description  |
|--------------|--|
| Not Related  | <ul style="list-style-type: none"> <li>• <b>Exposure to the IP and/or corticosteroids and/or other immunosuppressant agents has not occurred</b></li> <br/> <li style="text-align: center;"><b>OR</b></li> <br/> <li>• <b>The administration of the IP and/or corticosteroids and/or other immunosuppressant agents and the occurrence of the AE are not reasonably related in time</b></li> <br/> <li style="text-align: center;"><b>OR</b></li> <br/> <li>• <b>The AE is considered likely to be related to an etiology other than the use of the IP and/or corticosteroids and/or other immunosuppressant agents; that is, there are no facts, evidence, or arguments to suggest a causal relationship to the IP and/or corticosteroids and/or other immunosuppressant agents.</b></li> </ul>   |
| Related      | <ul style="list-style-type: none"> <li>• The administration of the <b>IP and/or corticosteroids and/or other immunosuppressant agents</b> and the occurrence of the AE are reasonably related in time</li> <br/> <li style="text-align: center;"><b><u>AND</u></b></li> <br/> <li>• The AE could not possibly be explained by factors or causes other than <b>exposure to the IP and/or corticosteroids and/or other immunosuppressant agents</b></li> <br/> <li style="text-align: center;"><b><u>OR</u></b></li> <br/> <li>• <b>The administration of IP and/or corticosteroids and/or other immunosuppressant agents and the occurrence of the AE are reasonably related in time</b></li> <br/> <li style="text-align: center;"><b><u>AND</u></b></li> <br/> <li>• <b>The AE is more likely explained by exposure to the IP and/or corticosteroids and/or other immunosuppressant agents than by other factors or causes</b></li> </ul> |

**Factors suggestive of a causal relationship could include (but are not limited to):**

- Plausible temporal relationship
- Absence of alternative explanations
- Rarity of event in a given patient or disease state
- **Absence of event prior to study drug and/or corticosteroid and/or other immunosuppressant agent exposure**

- Consistency with study product pharmacology
- **Known relationship to underlying mechanism of study drug and/or corticosteroid and/or other immunosuppressant agent action**
- Similarity to adverse reactions seen with related drug products
- **Abatement of AE with discontinuation of study drug and/or corticosteroids and/or other immunosuppressant agents, and/or recurrence of AE with reintroduction of study drug and/or corticosteroids and/or other immunosuppressant agents**

The Investigator's assessment of causality for individual AE reports is part of the study documentation process. Regardless of the Investigator's assessment of causality for individual AE reports, the Sponsor will promptly evaluate all reported SAEs against cumulative product experience to identify and expeditiously communicate possible new safety findings to Investigators and applicable regulatory authorities.

#### 10.4 Procedures for Recording Adverse Events

##### 10.4.1 Recording Adverse Events on an eCRF

Investigators should use precise medical terminology when recording AEs or SAEs on the AE eCRF. **Avoid colloquialisms and abbreviations.**

Record only one diagnosis, sign, or symptom **per event field on the AE eCRF (eg, nausea and vomiting should not be recorded in the same entry, but as 2 separate entries).**

In order to classify AEs and diseases, preferred terms will be assigned by the Sponsor to the original terms entered on the AE eCRF, **using MedDRA (Medical Dictionary for Regulatory Activities) terminology.**

##### 10.4.1.1 Diagnosis versus Signs and Symptoms

The Investigator will attempt to establish a diagnosis of the event based on signs, symptoms, **and/or other clinical information. Whenever possible, the diagnosis (not the individual signs/symptoms) will be documented as the AE/SAE. Using accepted medical terminology, enter the diagnosis (if known). If not known, enter sign(s) and/or symptom(s). If a diagnosis subsequently becomes available, then this diagnosis should be entered on the AE (or SAE, as appropriate) eCRF, replacing the original entries where appropriate.**

##### 10.4.1.2 Adverse Events Occurring Secondary to Other Events

**In general, AEs occurring secondary to other events (eg, cascade events) should be identified by their primary cause. For example, if severe diarrhea is known to have resulted in dehydration, it is sufficient to record only diarrhea as an AE or SAE on the AE eCRF.**

**However, medically important events that may be linked and/or separated in time should be**

recorded as independent events on the AE eCRF. For example, if severe hemorrhage leads to renal failure, both events should be recorded separately on the AE eCRF.

#### 10.4.1.3 Persistent or Recurrent Adverse Events

**A persistent AE (duration of adverse event > 7 days) is one that extends continuously, without resolution, between subject evaluation time points. Events that change in severity necessitate the recording of an additional AE. AEs that do not have a change in severity should be recorded only once on the eCRF.**

A recurrent AE is one that occurs and resolves between subject evaluation time points, but **then subsequently recurs. All recurrences of the AE should be recorded on the AE eCRF. For example, if a subject has an adverse event of ALT increased that subsequently resolves, but the subject's ALT increases again, that should be reported as two adverse events – the initial ALT increase, and the second ALT increase.**

#### 10.4.1.4 Abnormal Laboratory Values

Laboratory test results will be recorded on the laboratory results pages of the eCRF, or appear on electronically produced laboratory reports submitted directly from the central laboratory, if applicable.

Any laboratory result abnormality fulfilling the criteria for a SAE or EOSI should be reported as such, and recorded in the AE eCRF.

**Any laboratory result abnormality of CTCAE Grade 4 or 5 should be recorded as an SAE in the AE eCRF.**

A clinical laboratory abnormality is considered clinically significant and should be documented as an AE if not refuted by a repeat test to confirm the abnormality and **any** one or more of the following conditions is met:

- Accompanied by clinical symptoms
- **Requiring a change in concomitant therapy (eg, addition of, interruption of, discontinuation of, or any other change in a concomitant medication, therapy or treatment).**
- **The abnormality suggests a disease and/or organ toxicity**
- **The abnormality is of a degree that requires active management (eg, change of dose, discontinuation of study drug, more frequent follow-up assessments, further diagnostic investigation, etc.)**

**This applies to** any protocol and non-protocol specified safety and efficacy laboratory result from tests performed after the first dose of study medication that falls outside the laboratory reference range and meets the clinical significance criteria.

**This does not apply to** any abnormal laboratory result that falls outside the laboratory reference range but that does not meet the clinical significance criteria (these will be analyzed and reported as laboratory abnormalities), those that are considered AEs of the type explicitly exempted by the protocol, or those which are a result of an AE that has already been reported.

For purposes of this study, laboratory tests showing a decreased level of FVIII activity should not be reported as adverse events unless there is an impact to clinical outcomes (eg, increased rate of bleeding, **worsening of joint disease**).

#### 10.4.1.5 Pre-existing Conditions

A pre-existing condition is one that is present prior to administration of BMN 270. Such conditions should be recorded as medical history on the appropriate eCRF.

A pre-existing condition should be recorded as an AE or SAE during the study **only** if the **frequency, intensity, or character of the condition worsens during the study period**. It is important to convey the concept that a pre-existing condition has changed by including applicable language in the **verbatim description of the event** (eg, *more frequent headaches*).

#### 10.4.1.6 General Physical Examination Findings

At screening, any clinically significant abnormality should be recorded as a pre-existing condition (refer to Section 10.4.1.5). During the study, **any new clinically significant findings and/or abnormalities discovered on physical examination that meet the definition of an AE (or an SAE) must be recorded and** documented as an AE or SAE on the AE eCRF.

#### 10.4.1.7 Hospitalization, Prolonged Hospitalization, or Surgery

Any AE that results in hospitalization or prolonged hospitalization should be documented and reported as an SAE unless specifically instructed otherwise in **this protocol** (refer to Section 10.2).

**There are some hospitalization scenarios that do not require reporting as an SAE when there is no occurrence of an AE.** These scenarios include planned hospitalizations or prolonged hospitalizations to:

- Perform a protocol-mandated efficacy measurement



- **Undergo a diagnostic or elective surgical procedure for a pre-existing medical condition that has not worsened**
- **Insert an in-dwelling IV catheter (such as a Port-a-Cath or other brand, if applicable) for administration of study drug or FVIII replacement therapy**
- **Receive scheduled therapy (study drug or otherwise) for the study indication**

#### 10.4.1.8 Deaths

All deaths that occur during the **AE reporting period (refer to Section 10.3.1)**, regardless of attribution, will be recorded on the AE eCRF and expeditiously reported to the Sponsor as an SAE.

When recording a death, the event or condition that caused or contributed to the fatal outcome should be recorded as the single medical concept on the eCRF. If the cause of death **is unknown and cannot be ascertained at the time of reporting, record “Unexplained Death” or “Death of Unknown Cause” on the AE eCRF.**

#### 10.4.1.9 Pregnancy

**Although not an AE per se, pregnancy in the partner of a subject taking trial medication** should be reported expeditiously to the Sponsor to facilitate outcome monitoring by the Sponsor. Pregnancy in partner should be reported during the period up to 5 years after viral infusion.

**Pregnancy in a partner should be reported within 24 hours of the site becoming aware of the pregnancy by entering the information on the Pregnancy eCRF and submitting to BPV within 24 hours of the site becoming aware of the event. The Investigator must make every effort to follow the subject’s partner (with that partner’s consent) through resolution of the pregnancy (delivery or termination) and to report the resolution on the Pregnancy Follow-up eCRF.**

**In the event of pregnancy in the partner of a study subject, the Investigator should make every reasonable attempt to obtain the woman’s consent for release of protected health information.**

**Abortion, whether therapeutic or spontaneous, should always be classified as an SAE (as the Sponsor considers these to be medically significant), recorded on the AE eCRF, and expeditiously reported to the Sponsor as an SAE.**

### 10.5 Reporting Requirements

#### 10.5.1 Expedited Reporting Requirements

**All SAEs and EOSI that occur during the course of the AE Reporting Period (refer to Section 10.3.1), whether or not considered related to study drug, must** be reported by entering



**the information in the AE eCRF and submitting to BPV within 24 hours** of the site becoming aware of the event. Investigators should not wait to collect information that fully documents the event before notifying BPV of an SAE. **BioMarin may be required to report certain SAEs to regulatory authorities within 7 calendar days of being notified about the event; therefore, it is important that Investigators submit any information requested by BioMarin as soon as it becomes available.** IND safety reports will be submitted within 7 calendar days for fatal or life-threatening **unexpected suspected adverse reactions (SUSARs)** and within **15** calendar days for other non-life-threatening **SUSARs**

The Sponsor is responsible for identifying, preparing **and reporting all SUSARs to the** relevant competent authorities, ethics committees and Investigators in accordance with the **requirements identified in the Clinical Trials Regulations.**

If the EDC is unavailable, all SAEs should be reported to BPV by completing the SAE **Report Form and faxing or emailing the completed form to BPV within 24 hours** of the site becoming aware of the event. Once the EDC is available, the information should be entered in the AE eCRF.

#### **10.5.2 Institutional Review Board or Independent Ethics Committee Reporting Requirements**

**Reporting of SAEs to the Independent Ethics Committee (IEC) or Institutional Review Board (IRB) will be done in compliance with the standard operating procedures and policies of the IEC/IRB and with applicable regulatory requirements. Adequate documentation must be obtained by BioMarin showing that the IEC/IRB was properly and promptly notified as required.**

#### **10.6 Follow-up of Subjects after Adverse Events**

**After the initial AE/SAE/EOSI report, the Investigator is required to** proactively follow each subject at subsequent visits/contacts. **All AEs/SAEs/EOSI will be followed until resolution, stabilization, the event is otherwise explained, or the subject is lost to follow-up. Resolution of AEs/SAEs/EOSI (with dates) should be documented** on the AE eCRF and submitted to BioMarin Pharmacovigilance and in the subject's medical record to facilitate source data verification.

For some SAEs and EOSI, the Sponsor may follow up by telephone, fax, electronic mail, **and/or a monitoring visit to obtain additional case details (eg, hospital discharge summary, consultant report, or autopsy report) deemed necessary to appropriately evaluate the SAE or EOSI report.**

## 10.7 Post-Study Adverse Events

At the last scheduled visit, the Investigator should instruct each subject to report, to the **Investigator and/or to BPV directly, any subsequent SAEs that the subject's personal physician(s) believes might be related to prior study drug.**

The Investigator should notify the study Sponsor of any death or SAE occurring at any time after a subject has discontinued or terminated study participation, if the Investigator believes that the death or SAE may have been related to prior study drug. The Sponsor should also be notified if the Investigator should become aware of the development of cancer or of a **congenital anomaly in a subsequently conceived offspring of a subject that participated in this study.**

## 10.8 Urgent Safety Measures

**The regulations governing clinical trials state that the Sponsor and Investigator are required to take appropriate urgent safety measures to protect subjects against any immediate hazards that may affect the safety of subjects, and that the appropriate regulatory bodies should be notified according to their respective regulations. According to the European Union (EU) Clinical Trial Directive 2001/20/EC, "...in the light of the circumstances, notably the occurrence of any new event relating to the conduct of the trial or the development of the investigational medicinal product where that new event is likely to affect the safety of the patients, the Sponsor and the Investigator shall take appropriate urgent safety measures to protect the patients against any immediate hazard. The Sponsor shall forthwith inform the competent authorities of those new events and the measures taken and shall ensure that the IRB/IEC/REB is notified at the same time."**

**The reporting period for these events which may require the implementation of urgent safety measures is the period from the time of signing of the ICF through the completion of the last study visit or at the Early Termination Visit (ETV). Investigators are required to report any events which may require the implementation of urgent safety measures to BioMarin within 24 hours of becoming aware of the event.**

Examples of situations that may require urgent safety measures include discovery of the following:

- **Lack of study scientific value, or detrimental study conduct or management**
- **Discovery that the quality or safety of the IP does not meet established safety requirements<sup>S</sup>**

**10.9 BioMarin Pharmacovigilance Contact Information**

Contact information for BioMarin Pharmacovigilance is as follows:

BioMarin Pharmaceutical Inc.

Address:  PI

Phone: 

Fax: 

E-mail: 

The Investigator is encouraged to discuss with the Medical Monitor any AEs for which the **issue of seriousness is unclear or questioned. Contact information for the Medical Monitor is as follows:**

Name: , MD, PhD

Address:  PI

Phone: 

E-mail: 

## 11 APPROPRIATENESS OF MEASUREMENTS

The measures of efficacy to be used in this study are standard, ie, widely used and generally recognized as reliable, accurate, **and relevant (able to discriminate between effective and ineffective agents)**. **The measures of safety used in this study are routine clinical and laboratory procedures.**

The chromogenic substrate FVIII assay and the one-stage clotting FVIII assay are both **validated and utilize CE marked reagents**. **The exploratory FVIII activity assay will be used for exploratory purposes only.**

## 12 STUDY PROCEDURES

### 12.1 Prestudy

An ICF must be signed and dated by the patient, the Investigator or designee and witness (if required) before any study-related procedures are performed.

### 12.2 Screening Visit

Screening assessments should be performed within 28 days of BMN 270 infusion (and must be performed within 42 days prior to BMN 270 infusion), while baseline assessments will take place within 7 days prior to BMN 270 infusion (Day 1). Should the screening visit occur within 30 days of the drug infusion, physical examination, vital signs, blood chemistry, LTs, hematology, urine tests, and coagulation tests do not need to be repeated at Baseline.

The following procedures will be performed during the Screening Period:

- **Demographics (age, sex, race, ethnicity)**
- Full medical history, including hemophilia A history, Hepatitis B, Hepatitis C, and HIV. Subjects with a history of hepatitis B or hepatitis C will be asked for information about the treatments received. Any prior pharmacokinetics information obtained while the subject was receiving prophylactic or on-demand FVIII therapy prior to the study should also be collected.
- Complete Physical Examination
- Height and weight
- **Vital Signs (systolic and diastolic blood pressure, heart rate, respiration rate, and temperature)**
- Assessment of Adverse Events and Concomitant Medications
- **Documentation of bleeding episodes and FVIII usage (by either subject or clinical information) for the previous 12 months**
  - Further information on details to be included in documentation of previous bleeding episodes and FVIII usage, refer to the On Site File Binder.
- Distribution of subject diaries and training in diary completion
- Electrocardiogram
- **Liver Ultrasound**
- Samples for hFVIII Assays
  - Baseline FVIII activity – chromogenic substrate FVIII assay
  - Baseline FVIII activity level – one-stage clotting FVIII assay

- hFVIII coagulation activity exploratory assay (collected but not tested prior to enrollment)
- hFVIII inhibitors (Bethesda assay with Nijmegen modification)
- hFVIII total antibody assay (collected but not tested prior to enrollment)
- hFVIII protein assay (collected but not tested prior to enrollment)
- **Blood sample for AAV5 total antibody (TA<sub>b</sub>) assay**
- **Screen for Hepatitis B, Hepatitis C, and HIV if required (subjects with documented negative results 30 days prior to informed consent being obtained do not need to be retested)**
  - Hepatitis B screening should include HBsAg, HBsAb, and HBcAb.
- **Blood chemistry, hematology, and coagulation tests (refer to Table 9.7.8.2.1)**
- **Urine Tests (refer to Table 9.7.8.2.1)**
- **Liver Tests (refer to Table 9.7.8.4.1)**
- **Blood samples for Biomarker testing (including HLA genotyping and FVIII genotyping status)**

#### 12.2.1 “Smart Rescreening” Visit

Subjects who undergo smart rescreening must complete the rescreening assessments and **receive the infusion within 90 days** of signing the original consent. Subjects who do not **complete dosing within 90 days will be required to re-consent** and undergo all screening procedures. Subjects may not undergo smart rescreening more than once.

If a patient has to be screened again because the original assessments have fallen out of the **28 + 14 day period allowed for Screening (refer to Section 12.2)**, then **only the following assessments need to be performed (rather than the full list indicated in Section 12.2)** for the patient to be successfully re-screened for the study:

- Vital signs
- Assessment of Adverse Events and Concomitant Medications
- **Documentation of bleeding episodes and FVIII usage (by either subject or clinical information)**
- **hFVIII Assays (only the hFVIII inhibitor level (Bethesda assay with Nijmegen modification))**
- AAV5 Total Antibody assay
- **Blood chemistry, hematology, and coagulation tests (refer to Table 9.7.8.2.1)**

- Urine Tests (refer to [Table 9.7.8.2.1](#))
- Liver Tests (refer to [Table 9.7.8.4.1](#))

### 12.3 Baseline Visit

**Baseline values will be recorded from 1 to 7 days prior to the treatment visit. The following procedures will be performed during the Baseline Period:**

- Brief physical examination
- Vital signs
- Assessment of Adverse Events and Concomitant Medications
- **Documentation of bleeding episodes and FVIII usage (by either subject or clinical information)**
- Blood sample for AAV5 TI assay
- Blood sample for AAV5 TAb assay
- Blood chemistry, hematology, and coagulation tests (refer to [Table 9.7.8.2.1](#))
  - ABO blood typing assessment should be performed at Baseline, or at another regularly scheduled visit prior to the end of the subject's participation in the study.
- Urine Tests (refer to [Table 9.7.8.2.1](#))
- Liver Tests (refer to [Table 9.7.8.4.1](#))
- Samples for hFVIII Assays
  - Baseline FVIII activity – chromogenic substrate FVIII assay
  - Baseline FVIII activity level – one-stage clotting FVIII assay
  - hFVIII coagulation activity exploratory assay
  - **hFVIII inhibitors (Bethesda assay with Nijmegen modification)**
  - hFVIII total antibody assay
  - hFVIII protein assay
- PBMC collection for CTL baseline
- **Von Willebrand Factor Antigen (VWF:Ag)**
- TGA Assay
- PCR of vector DNA in blood, saliva, urine, semen, and stools
- **Exploratory biomarker assessments**
- Haemo-QoL-A assessment



- EQ-5D-5L
- **Hemophilia Activities List (HAL)**
- **Work Productivity and Activity Impairment plus Classroom Impairment Questions: Hemophilia Specific (WPAI+CIQ:HS) questionnaire**
- **Patient Reported Outcomes, Burdens, and Experiences (PROBE) questionnaire**

#### 12.4 Treatment Visit/BMN 270 Infusion Visit (Day 1)

There will be one treatment visit for each subject. Subjects will remain in the clinic for at **least 8** hours for the BMN 270 Infusion Visit. The following procedures will be performed during the BMN 270 Infusion Visit:

- Brief physical examination
- Assessment of Adverse Events and Concomitant Medications
- **AAV5 TAb Assay (sample collected pre-infusion for analysis)**
- **Fasting lipid panel (blood triglycerides, total cholesterol, HDL cholesterol, and LDL cholesterol) (sample collected pre-infusion)**
  - **Subjects will fast for at least 8 hours prior to pre-infusion laboratory sampling on the day of the infusion visit.**
- BMN 270 Infusion
- Vital Signs
  - Vital signs will be recorded prior to BMN 270 infusion and then every **15 minutes (± 5 minutes) during BMN 270 infusion**. Following infusion, **vital signs will be monitored every 1 hour (± 5 minutes) for at least 8 hours** during the subject's stay in the clinic.
- PCR of vector DNA in blood, saliva, urine, semen, and stools
  - Collection of samples for PCR testing should occur between 2 and **24** hours after the BMN 270 infusion has been completed

In case of hypersensitivity or adverse drug reaction, safety assessment, including physical examination and vital signs, will be done and additional blood samples will be collected **within 1 hour of the hypersensitivity reaction (eg, tryptase, C3, C3a, C4, C5, C5a, and cytokine bead array, as well as possible additional exploratory testing) and samples for IgE and cytokine bead array (and possible additional exploratory testing) between 8-24 hours** after the reaction, if possible. In addition, a blood sample **should be taken 1 week after the hypersensitivity reaction for assessment of the cytokine bead array**. In-patient observation can be extended and additional blood samples can be collected if deemed necessary at the discretion of the Investigator and Medical Monitor.



## 12.5 BMN 270 Infusion Follow-Up Visits – Weeks 1-26

After BMN 270 has been infused, subjects will return to the study site every week ( $\pm$  48 hours) during Weeks 1-26. For subjects who have enrolled in 270-301 following participation in 270-902, optional MN services or shortened lab draw-only site visits may be conducted for the visits at Week 5, Week 7, Week 9, Week 11, Week 13, Week 15, Week 17, Week 19, Week 21, Week 23, and Week 25. At visits not specifically designated for MN eligibility (ie, visits where the subject is intended to return to the site for assessment), MN services may be used if the subject is unable to attend the site to complete the study visit during the acceptable window for that visit, upon prior approval by the Medical Monitor and discussion between the Medical Monitor and Investigator. In the event that neither a lab-only visit or MN visit can be conducted, the site should telephone the subject to collect adverse event, concomitant medication, and diary data (bleeding events and FVIII usage).

During Year 1, subjects may consent to an optional liver biopsy. If such a procedure is planned, refer to Section 12.9 for assessments related to performing the liver biopsy.

At the Weeks 1-26 visits, the following procedures will be completed:

### 12.5.1 Once per week (Weeks 1 through 26)

The following procedures will be performed at one visit per week from Weeks 1 through 26:

- **Brief physical examination (complete physical examination at Week 26)**
  - For visits where a MN service is being used or a lab draw-only site visit is conducted, physical examination will not be performed.
- **Assessment of Adverse Events and Concomitant Medications (including review of subject diary for bleeding and FVIII use)**
  - For visits where a MN service is being used, the service will contact the subject via e-mail or phone call to collect information regarding adverse events, changes to concomitant medications, bleeding episodes, and FVIII use.
- **Vital Signs**
  - For visits where a MN service is being used or a lab draw-only site visit is conducted, vital signs will not be performed.

- **Liver Tests (refer to [Table 9.7.8.4.1](#))**
  - **LTs may be monitored more or less frequently (and in particular when ALT values are > ULN or  $\geq 1.5x$  baseline value) based on discussion between the Medical Monitor and the Investigator and review of subject data, but LTs will be monitored at least twice weekly during periods when a subject's ALT is  $\geq 3x$  ULN.**
- **Samples for FVIII Assays**
  - **FVIII activity level (chromogenic substrate FVIII assay)**
  - **FVIII activity level (one-stage clotting FVIII assay)**
  - **FVIII coagulation activity exploratory assay**
  - **Bethesda assay (with Nijmegen modification) for hFVIII inhibitor level**
  - **FVIII protein assay**

#### 12.5.2 Week 1 – Day 4

**On Day 4 of Week 1, the following procedures will be performed:**

- **Assessment of Adverse Events and Concomitant Medications (including review of subject diary for bleeding and FVIII use)**
- **PCR of vector DNA in blood, saliva, urine, semen, and stools**
- **Liver Tests (refer to [Table 9.7.8.4.1](#))**

#### 12.5.3 Week 1 – Day 8

**On Day 8, the following procedures will be performed, in addition to the weekly assessments required in [Section 12.5.1](#):**

- **PCR of vector DNA in blood, saliva, urine, semen, and stools**

#### 12.5.4 Every 2 Weeks (Week 2, 4, 6, 8, 10, 12, 14, 16, 18, 20, 22, 24, and 26)

**At Weeks 2, 4, 6, 8, 10, 12, 14, 16, 18, 20, 22, 24, and 26 the following procedure will be performed:**

- **PBMC collection**

#### 12.5.5 Weeks 2, 4, 10, 16, 22, and 26

**At Weeks 2, 4, 10, 16, 22, and 26 the following procedure will be performed:**

- **Blood chemistry, hematology, and coagulation tests (refer to [Table 9.7.8.2.1](#))**

**12.5.6 Weeks 2, 3, 4, 6, 8, 12, 16, 20, 24, and 26**

**At Weeks 2, 3, 4, 6, 8, 12, 16, 20, 24, and 26, the following procedure will be performed:**

- PCR of vector DNA in blood, saliva, urine, semen, and stools
  - Collection to occur until at least 3 consecutive results below the limit of detection are obtained. Semen samples should continue to be collected **and tested through Week 12, even if 3 consecutive results** below the limit of detection in that compartment have been recorded prior to that time point.

**12.5.7 Weeks 4, 12, and 26**

**At Weeks 4, 12, and 26, the following procedure will be performed:**

- Haemo-QoL-A assessment
- EQ-5D-5L
- HAL
- WPAI+CIQ:HS
- PROBE

**12.5.8 Every 4 Weeks (Weeks 4, 8, 12, 16, 20, and 24) Plus Week 26**

**At Weeks 4, 8, 12, 16, 20, 24, and 26, the following procedures will be performed:**

- **Weight (not performed at Week 26)**
- FVIII antibody titer

**12.5.9 Every 8 Weeks (Weeks 8, 16, and 24)**

**At Weeks 8, 16, and 24, the following procedures will be performed:**

- AAV5 TAb assay
- AAV5 TI assay

**12.5.10 Weeks 6, 12, 16, 20, 24, and 26**

**At Weeks 6, 12, 16, 20, 24, and 26, the following procedures will be performed:**

- **Exploratory biomarker assessments**

**12.5.11 Weeks 12 and 26**

**At Weeks 12 and 26, the following procedures will be performed:**

- **Urine Tests (refer to [Table 9.7.8.2.1](#))**
- VWF:Ag

### 12.5.12 Week 16

At Week 16, the following procedure will be performed:

- **Test for Hepatitis B and Hepatitis C reactivation (only in subjects with evidence of prior exposure to hepatitis B and/or hepatitis C)**
  - **Subjects who receive therapeutic oral corticosteroids prior to Week 16 do not need to complete the Week 16 reactivation assessment; instead, they will be tested for hepatitis B and hepatitis C reactivation at the time points listed in [Table 9.1.6](#).**

### 12.5.13 Week 20, 24, and 26

At Week 20, 24, and 26, the following procedure will be performed:

- TGA Assay

### 12.6 Post-Infusion Follow-Up – Weeks 27-52

During Weeks 27-36, subjects will return to the study site weekly ( $\pm$  48 hours). During Weeks 37-52, subjects will return to the study site every 2 weeks (Week 38, 40, 42, 44, 46, 48, 50, and 52) ( $\pm$  1 week). For subjects who have enrolled in 270-301 following participation in 270-902, optional MN services or shortened lab draw-only site visits may be conducted at Week 27, Week 29, Week 30, Week 31, Week 33, Week 34, Week 35, Week 38, Week 42, Week 46, and Week 50. At visits not specifically designated for MN eligibility (ie, visits where the subject is intended to return to the site for assessment), MN services may be used if the subject is unable to attend the site to complete the study visit during the acceptable window for that visit, upon prior approval by the Medical Monitor and discussion between the Medical Monitor and Investigator. In the event that neither a lab-only visit or MN visit can be conducted, the site should telephone the subject to collect adverse event, concomitant medication, and diary data (bleeding events and FVIII usage).

During Year 1, subjects may consent to an optional liver biopsy. If such a procedure is planned, refer to Section [12.9](#) for assessments related to performing the liver biopsy.

At these visits, the following procedures will be completed:

#### 12.6.1 Every Visit

At every visit (Weeks 27-36, 38, 40, 42, 44, 46, 48, 50, and 52), the following procedures will be performed:

- Physical examination
  - **Brief physical examination should be performed at all weeks except Week 26, when a complete physical examination should be performed**

- For visits where a MN service is being used or a lab draw-only site visit is conducted, physical examination will not be performed.
- **Assessment of Adverse Events and Concomitant Medications (including review of subject diary for bleeding and FVIII use)**
  - For visits where a MN service is being used, the service will contact the subject via e-mail or phone call to collect information regarding adverse events, changes to concomitant medications, bleeding episodes, and FVIII use.
- Vital Signs
  - For visits where a MN service is being used or a lab draw-only site visit is conducted, vital signs will not be performed.
- **Liver Tests (refer to [Table 9.7.8.4.1](#))**
  - **LTs may be monitored more or less frequently (and in particular when ALT values are > ULN or  $\geq 1.5x$  baseline value) based on discussion between the Medical Monitor and the Investigator and review of subject data, but LTs will be monitored at least twice weekly during periods when a subject's ALT is  $\geq 3x$  ULN.**
- FVIII Assays
  - **FVIII activity level (chromogenic substrate FVIII assay)**
  - **FVIII activity level (one-stage clotting FVIII assay)**
    - FVIII coagulation activity exploratory assay
    - **Bethesda assay (with Nijmegen modification) for FVIII inhibitor level**
    - FVIII protein assay

#### 12.6.2 Weeks 28, 32, 36, 44, and 52

At Weeks 28, 32, 36, 44, and 52, the following procedure will be performed:

- PBMC collection

#### 12.6.3 Every 4 Weeks (Weeks 28, 32, 36, 40, 44, 48, 52)

At Weeks 28, 32, 36, 40, 44, 48, and 52, the following procedure will be performed:

- Weight

#### 12.6.4 Weeks 32, 36, 44, and 52

At Weeks 32, 36, 44, and 52, the following procedures will be performed:

- **Blood chemistry, hematology, and coagulation tests (refer to [Table 9.7.8.2.1](#))**

- FVIII antibody titer

#### 12.6.5 Weeks 32, 36, 40, 44, 48, and 52

**At Weeks 32, 36, 40, 44, 48, and 52, the following procedures will be performed:**

- **Exploratory biomarker assessments**
- TGA Assay
- PCR of vector DNA in blood, saliva, urine, semen, and stools
  - Sample testing to occur until at least 3 consecutive sample results below the limit of detection have been obtained. Subjects who have not had 3 consecutive semen samples below the limit of detection **by Week 52** should **continue to have PCR testing of semen every 4 weeks until 3 consecutive samples below the limit of detection are documented (or upon consultation between the Investigator and Medical Monitor).**

#### 12.6.6 Week 32, 36, and 52

**At Week 32, 36, and 52, the following procedure will be performed:**

- AAV5 TAb Assay
- AAV5 TI Assay

#### 12.6.7 Week 36 and 52

**At Weeks 36 and 52, the following procedures will be performed:**

- **Urine Tests (refer to [Table 9.7.8.2.1](#))**
- VWF:Ag

#### 12.6.8 Week 52

**At Week 52, the following procedures will be performed:**

- Haemo-QoL-A assessment
- EQ-5D-5L
- HAL
- WPAI+CIQ:HS
- PROBE

**At Week 52, the following optional procedure may be performed:**

- **Optional liver biopsy (refer to [Section 12.9](#) for assessments related to liver biopsy)**

## 12.7 Post-Infusion Follow-Up – Years 2-5

During Years 2-5, at applicable sites, certain study assessments may be performed by a **mobile nursing (MN) professional at the patient's home or another suitable location, such as** their school or office, to improve access and convenience for patients participating in the study. The Sponsor may select a healthcare company that will be responsible for providing **MN services for participating sites (the MN vendor). The MN vendor is responsible for ensuring that all MN professionals are licensed, qualified, and in good standing, as per** applicable regulations, and that appropriate **background checks have been performed. If the** investigator at a participating site determines that MN services are appropriate for a patient **and the patient gives written informed consent to participate in MN visits, the MN network** will communicate with the patient and the patient's site. MN visits will be allowed for the **Q4W (during Year 2) and Q6W (during Years 3-5) visits; the Q12W visits and End of Year** visits during Years 2-5 will not be performed by an MN professional but will be done at the study site. **At visits not specifically designated for MN eligibility (ie, visits where the subject is intended to return to the site for assessment), MN services may be used if the subject is** unable to attend the site to complete the study visit during the acceptable window for that visit, upon prior approval by the Medical Monitor and discussion between the Medical Monitor and Investigator.

**Subjects who do not respond to BMN 270 treatment (ie, treatment failure, manifesting as** failure to achieve FVIII activity  $\geq 5$  IU/dL **by Week 52 and inability to maintain independence** from prophylactic FVIII replacement therapy due to joint bleeding episodes, in the judgment **of the Investigator) may, at the Investigator's discretion and after discussion with the Medical** Monitor or Sponsor-designated Data Monitor, follow an abbreviated visit schedule after **Week 52 of the study by attending only the Q12W and End of Year visits during Years 2-5. Subjects who are not attending the Q4W/Q6W visits during Years 2-5 may receive a** scheduled monthly follow-up telephone call from the site to ask about adverse events, **concomitant medications, and bleeding events/FVIII replacement usage.**

Subjects who meet the definition of treatment failure and wish to follow an abbreviated schedule but who have not cleared vector shedding from all fluids must still provide samples **for assessment every 4 weeks (during Year 2) or every 6 weeks (during Years 3-5) until** vector shedding has cleared. Such subjects may provide samples on the designated study visit dates either at the sites or through use of a MN professional.

During Years 2-5 of Post-Infusion Follow-up, the following procedures will be completed:



### 12.7.1 Year 2 – Every 4 Weeks (not required for treatment failure)

During Year 2, every 4 weeks ( $\pm 2$  weeks), the following procedures will be performed:

- **Assessment of Adverse Events and Concomitant Medications (including review of subject diary for bleeding and FVIII use)**
- **Liver Tests (refer to [Table 9.7.8.4.1](#))**
  - **LT assessment may be checked more or less frequently when ALT values are  $> \text{ULN}$  or  $\geq 1.5x$  baseline value or based upon discussion between the Medical Monitor and the Investigator and review of subject data.**
- **FVIII Assays**
  - **FVIII activity level (chromogenic substrate FVIII assay)**
  - **FVIII activity level (one-stage clotting FVIII assay)**
  - **FVIII coagulation activity exploratory assay**
  - **Bethesda assay (with Nijmegen modification) for FVIII inhibitor level**
- **PCR of vector DNA in semen (if required)**
  - **Subjects who have not had 3 consecutive semen samples below the limit of detection by Week 52 should continue to have PCR testing of semen every 4 weeks during Year 2 until 3 consecutive samples below the limit of detection are documented (or upon consultation between the Investigator and Medical Monitor).**
  - **Subjects who meet the definition of treatment failure and wish to follow an abbreviated schedule but who have not cleared vector shedding in semen must still provide semen samples for assessment every 4 weeks during Year 2 until vector shedding has cleared. Such subjects may provide samples on the designated study visit dates either at the sites or through use of a MN professional.**

### 12.7.2 Years 3-5 – Every 6 Weeks (not required for treatment failure)

During Years 3-5, every 6 weeks ( $\pm 2$  weeks), the following procedures will be performed:

- **Assessment of Adverse Events and Concomitant Medications (including review of subject diary for bleeding and FVIII use)**
- **Liver Tests (refer to [Table 9.7.8.4.1](#))**
  - **LT assessment may be checked more frequently when ALT values are  $> \text{ULN}$  or  $\geq 1.5x$  baseline value or based upon discussion between the Medical Monitor and the Investigator and review of subject data.**
- **FVIII Assays**



- FVIII activity level (chromogenic substrate FVIII assay)
- FVIII activity level (one-stage clotting FVIII assay)
- FVIII coagulation activity exploratory assay
- **Bethesda assay (with Nijmegen modification) for FVIII inhibitor level**
  - **If a subject tests positive in the Bethesda assay (with Nijmegen modification) during Years 3-5, a fresh sample should be collected within 4 weeks of the initial visit that had a positive result.**
- **PCR of vector DNA in semen (if required)**
  - Subjects who have not had 3 consecutive semen samples below the limit of detection by the end of Year 2 should continue to have PCR testing of semen **every 6 weeks during Years 3-5** until 3 consecutive samples below the limit of detection **are documented (or upon consultation between the Investigator and Medical Monitor)**.
  - Subjects who meet the definition of treatment failure and wish to follow an abbreviated schedule but who have not cleared vector shedding in semen by the end of Year 2 must still provide semen samples for **assessment every 6 weeks during Years 3-5** until vector shedding has cleared. Such subjects may provide samples on the designated study visit dates either at the sites or through use of a MN professional.

### 12.7.3 Years 2-5 – Every 12 Weeks and End of Year Visits (required for all subjects)

During Years 2-5, **subjects will be asked to return to the study site for visits at the following study weeks ( $\pm 2$  weeks):**

- Year 2 – **Week 64, Week 76, Week 88, Week 104**
- Year 3 – **Week 116, Week 128, Week 140, Week 156**
- Year 4 – **Week 168, Week 180, Week 192, Week 208**
- Year 5 – **Week 220, Week 232, Week 244, Week 260**

**For each of these years, the last study visit listed (Week 104, Week 156, Week 208, and Week 260) will serve as an End of Year visit. The every 12 week and End of Year visits may not be performed remotely by MN services.**

**At the every 12 week and End of Year visits, the following procedures will be performed:**

- Physical examination
  - Complete physical examination will be performed at the End of Year **visits (genitourinary examination may be deferred); brief physical examination may be performed at other visits.**

- **Weight (at Week 76, Week 128, Week 180, Week 232, and End of Year visits only)**
- **Assessment of Adverse Events and Concomitant Medications (including review of subject diary for bleeding and FVIII use)**
- **Liver Tests (refer to Table 9.7.8.4.1)**
  - **LT assessment may be checked more or less frequently when ALT values are  $> \text{ULN}$  or  $\geq 1.5x$  baseline value or based upon discussion between the Medical Monitor and the Investigator and review of subject data.**
- **FVIII Assays**
  - **FVIII activity level (chromogenic substrate FVIII assay)**
  - **FVIII activity level (one-stage clotting FVIII assay)**
  - **FVIII coagulation activity exploratory assay**
  - **Bethesda assay (with Nijmegen modification) for FVIII inhibitor level**
    - **If a subject tests positive in the Bethesda assay (with Nijmegen modification) during Years 3-5, a fresh sample should be collected within 4 weeks of the initial visit that had a positive result.**
- **FVIII protein assay**
- **Blood chemistry, hematology, and coagulation tests (refer to Table 9.7.8.2.1) (at Week 76, Week 128, Week 180, Week 232, and End of Year visits only)**
- **Urine Tests (refer to Table 9.7.8.2.1) (at Week 76, Week 128, Week 180, Week 232, and End of Year visits only)**
- **Vital Signs**
- **AAV5 TAb Assay (at Week 64, Week 76, Week 88, Week 104, then at End of Year visit for Years 3-5)**
- **AAV5 TI Assay (at End of Year 5 visit only)**
- **FVIII antibody titer (at Week 64, Week 76, Week 88, Week 104, then at End of Year visit for Years 3-5)**
- **Haemo-QoL-A assessment (at Week 76, Week 128, Week 180, Week 232, and End of Year visits only)**
- **EQ-5D-5L (at Week 76, Week 128, Week 180, Week 232, and End of Year visits only)**
- **HAL (at Week 76, Week 128, Week 180, Week 232, and End of Year visits only)**
- **WPAI+CIQ:HS (at Week 76, Week 128, Week 180, Week 232, and End of Year visits only)**
- **PROBE (at Week 76, Week 128, Week 180, Week 232, and End of Year visits only)**

- **Exploratory biomarker assessments**
- PBMC collection
- VWF:Ag
- **PCR of vector DNA in blood, saliva, urine, semen, and stools (if required)**
  - Sample testing during Years 2-5 is not required in a matrix if at least 3 consecutive samples are below the limit of detection in that matrix during the Post-Infusion Follow-Up period in Weeks 1-52.
- **Liver ultrasound (at End of Year visits only)**
  - Additional liver ultrasounds may be performed at interim time points (ie, between the End of Year visits) at the discretion of the Investigator.
- **Optional liver biopsy (Years 2-5) (refer to Section 12.9 for assessments related to liver biopsy)**

## 12.8 Early Termination Visit

The Early Termination visit will occur on the date the subject withdraws from the study, even if the date does not correspond to a protocol-specific visit.

If a subject **leaves the study prior to the Week 260 visit, the subject will be asked to return to the study site and complete an Early Termination visit.** At the Early Termination visit, as many of the following assessments as possible should be done:

- Physical examination
- Weight
- **Assessment of Adverse Events and Concomitant Medications (including review of subject diary for bleeding and FVIII use)**
- Vital Signs
- **Blood chemistry, hematology, and coagulation tests (refer to Table 9.7.8.2.1)**
- **Urine Tests (refer to Table 9.7.8.2.1)**
- **Liver Tests (refer to Table 9.7.8.4.1)**
- FVIII Assays
  - **FVIII activity level (chromogenic substrate FVIII assay)**
  - **FVIII activity level (one-stage clotting FVIII assay)**
  - FVIII coagulation activity exploratory assay
  - **Bethesda assay (with Nijmegen modification) for FVIII inhibitor level**
  - FVIII protein assay

- AAV5 TAb Assay
- AAV5 TI Assay
- FVIII antibody titer
- **Exploratory biomarker assessments**
- PBMC collection
- VWF:Ag
- Liver ultrasound
- PCR of vector DNA in blood, saliva, urine, semen, and stools
  - **Sample testing at the ETV is not required if at least 3** consecutive samples were clear during the Post-Infusion Follow-Up period.
- Haemo-QoL-A assessment
- EQ-5D-5L
- HAL
- **WPAI+CIQ:HS**
- PROBE

## 12.9 Optional Liver Biopsy

**Details on required procedures for the optional liver biopsy are outlined in [Table 9.1.7](#). Subjects may be asked to provide a liver biopsy during Year 1, at or around Week 52, and during the Years 2-5 period post-BMN 270 infusion.**

Subjects consenting to participate to the optional liver biopsy will undergo pre-biopsy **assessments within 28 days before the procedure, as follows:**

- Liver **ultrasound (subject should fast at least 8 hours prior to ultrasound)**
- Physical examination
- Hematology, coagulation, chemistry assessments
- Liver tests
- FibroScan

Subjects consenting to participate to the optional liver biopsy will undergo pre-biopsy assessments **within 7 days** before the procedure, as follows:

- **FVIII activity level assessment (central and local)**
- **Exploratory CK18 and Grp78 assessment**

- **Pre-biopsy consultation (with hepatologist and/or radiologist)**

On the day of the biopsy, brief physical examination and liver and blood tests should be **performed before the procedure (including hematology, coagulation, and chemistry)**. FVIII activity assessment should also be performed to ensure the subject has sufficient FVIII activity to protect against procedure-**related bleeding (as discussed above)**. **LT assessment** and a whole blood draw for PBMC collection should be performed on the biopsy day or **± 1 week from the biopsy day**.

The optional liver biopsy should be performed in the morning if feasible, and the biopsy procedure and follow-up care should be done according to the local standard of care. Additional details for handling the biopsy specimens are provided in the Laboratory Manual.

Following completion of the biopsy, the subject should remain under observation in the clinic **for at least 4-6 hours**. **Overnight post-procedure** observation may be done at the investigator's **discretion and/or according to local guidelines**.

#### **12.10 End of Study**

The study will end after the last subject yet to complete the last Long-Term Follow-**Up visit (Week 260) does so, has transferred to another BMN 270 study**, is withdrawn from the study, or discontinues from the study. BioMarin reserves the right to discontinue the study any time for clinical or administrative reasons and to discontinue participation of an individual Investigator or site for clinical or administrative reasons, including, but not limited to, poor enrollment or noncompliance with procedures of the protocol or GCP. In addition, the study may be terminated if, in the opinion of BioMarin, the safety of the study subjects may be compromised.

### 13 DATA QUALITY ASSURANCE

BioMarin personnel or designees will visit the study site prior to initiation of the study to review with the site personnel information about the IP, protocol and other regulatory **document requirements, source document requirements, eCRFs, monitoring requirements,** and procedures for reporting AEs, including SAEs.

At visits during and after the study, a CRA will monitor the site for compliance with regulatory documentation, with a focus on accurate and complete recording of data on eCRFs from source documents, **adherence to protocol, randomization (if applicable), SAE reporting** and drug accountability records.

**Data quality control and analysis will be performed by BioMarin or a designee, based on a predefined analysis plan.**

## 14 STATISTICAL METHODS AND DETERMINATION OF SAMPLE SIZE

Additional statistical information for the **2-year analysis for the United States is provided in Appendix 2 (Section 25) of this protocol.**

### 14.1 Statistical and Analytical Plans

**The statistical analysis plan (SAP) will provide additional details on the planned statistical analysis. Unless otherwise stated, all analyses will be performed using SAS.**

#### 14.1.1 Interim Analyses

Two interim analyses were **planned, after approximately 16 and 20 treated HIV-negative subjects, respectively, completed the Week 26 visit (or have discontinued study participation prior to Week 26). The first interim analysis was performed as planned in May 2019. Based on the interim results and the totality of the data, the secondary interim analysis was deemed unnecessary. The DMC reviewed the interim analysis results to assess the efficacy and safety profiles, whether the pre-specified criteria of statistical significance has been achieved, and the risk/benefit ratio of the interventions in the BMN 270 studies based on the totality of the data.**

The primary efficacy endpoint for the interim analyses involves hFVIII activity, as measured by chromogenic substrate assay, achieved post-BMN 270 infusion.

**The fallback procedure (Wiens 2005) will be used to adjust for multiplicity of the two interim analyses at Week 26, the 1-year analysis at Week 52, and the 2-year analysis at Week 104 (regardless of the analyses results, the study is planned to continue upon the DMC's recommendation). At the 1-year analysis at Week 52 and the 2-year analysis at Week 104, the secondary efficacy endpoints will be tested hierarchically; the level of significance will be determined by the fallback procedure.**

The secondary and tertiary endpoints will be summarized descriptively at the interim **(Week 26) analyses.**

The details of the interim analyses, including the control of Type I error rate, will be specified in the SAP.

#### 14.1.2 Procedures for Accounting for Missing, Unused and Spurious Data

Because the completeness of the data affects the integrity and accuracy of the final study analysis, every effort should be made to ensure complete, accurate, and timely data collection and, therefore, avoid missing data.



Missing data imputation and sensitivity analyses to assess the impact of missing data on the primary and secondary efficacy endpoints analyses are described in the following sections. Additional details regarding the handling of missing data will be provided in the SAP.

#### 14.2 Primary Efficacy Endpoint

**For the primary efficacy endpoint at Week 52 (ie, the change in the hFVIII activity during Weeks 49-52 post-BMN 270 infusion from baseline, as measured by chromogenic substrate assay), a one-sample t-test will be used to test the null hypothesis that the change is 0 or less against the alternative hypothesis that the change is greater than 0. Descriptive summaries of the proportions of subjects whose FVIII activity during Weeks 49-52 is greater than or equal to select thresholds, such as 15, 25 and 30 IU/dL, and the confidence intervals of the proportions will also be provided.**

For a subject with a missing value of the primary endpoint, the median value in the subject's **last 4-week window containing a valid observation will** be used. Additional analyses will be conducted to examine the sensitivity of the results to the handling of missing data, including **analysis using observed cases, and a mixed model for repeated measures (MMRM) approach.** Further detail will be provided in the SAP.

The analyses for the primary endpoint will be performed using the analysis populations as defined in Section [14.9](#).

#### 14.3 Secondary Efficacy Endpoints

**The primary analyses for the secondary endpoints will be performed on the 110 subjects in the mITT population who will be followed up for approximately 6 months in the non-interventional study 270-902 prior to their enrollment in 270-301. The baseline values will be derived from the prospectively collected data in 270-902.**

For the first-ranked secondary efficacy endpoint (ie, the change in the annualized utilization (IU/kg) of exogenous FVIII replacement therapy in the efficacy evaluation period ("Week 5 to Last Visit") from baseline), a one-sample t-test will be performed to test the null hypothesis that the change is 0 or greater against the alternative hypothesis that the change is less than 0. The missing value of the change will be imputed as 0.

For the second-ranked secondary efficacy endpoint at Week 52 (ie, the change in ABR in the efficacy evaluation period ("Week 5 to Last Visit") from baseline), a one-sample t-test will be performed to test for non-inferiority of BMN 270 against FVIII prophylaxis (ie, the baseline ABR calculated using subjects' data collected as part of 270-902) using a non-inferiority margin of 3.5, ie, to test the null hypothesis that the change is 3.5 or greater against the alternative hypothesis that the change is less than 3.5. If non-inferiority is



demonstrated, the test for superiority of BMN 270 against FVIII prophylaxis will be performed. The missing value of the change will be imputed using the median value of the changes of all observed cases.

A sensitivity analysis is planned to analyze ABR using a generalized linear mixed model assuming negative binomial as the underlying distribution. The model will include period **(pre- to post-BMN 270 infusion) as the only factor. The actual number of bleeding episodes will be used as the dependent variable with the time period adjustment (annualization) being implemented as the offset.**

To assess the impact of missing data, analyses using observed case are planned as sensitivity analyses for the secondary endpoints. Multiple imputation methods may also be performed.

The primary and secondary efficacy hypotheses will be tested hierarchically according to the order described above. Multiple comparison procedures will be described in greater detail in the SAP.

#### 14.4 Liver Biopsy Substudy Analysis

A separate report presenting and discussing analyses of the exploratory objectives for the optional liver biopsy substudy will be prepared.

#### 14.5 Immunogenicity

Analysis of total and neutralizing antibody response and other immunological parameters will be primarily descriptive and involve both inter-subject and intra-subject comparisons.

#### 14.6 Pharmacodynamic Analyses

Plasma FVIII protein concentrations and FVIII activities determined over the course of the study will primarily be evaluated and summarized with descriptive statistical measures **(eg, mean, standard deviation, CV%, min, median, max).**

#### 14.7 Safety Analysis

**The Medical Dictionary for Regulatory Activities terminology (MedDRA) will be used by the Sponsor to assign system organ class and preferred term classification to events and diseases, based on the original terms entered on the eCRF.**

All AEs will be coded using the current version of MedDRA. The incidence of AEs will be summarized by system organ class, preferred term, relationship to study drug, and severity.

**A by-subject listing will be provided for those subjects who experience a serious AE (SAE), including death, or experience an AE associated with early withdrawal from the study or study drug.**

Clinical laboratory data will be summarized by the type of laboratory test. For each clinical **laboratory test, descriptive statistics will be provided on Baseline as well as all subsequent visits.** Descriptive statistics for physical examination results and vital signs will also be provided.

Detailed statistical methods will be provided in the SAP.

#### 14.8 Determination of Sample Size

**Approximately one hundred and thirty (130) subjects may be dosed in the study. The sample size for this study is based on clinical and statistical considerations in order to provide sufficient data to assess both safety and efficacy of BMN 270.**

**For the primary endpoint, a sample size of 130 will provide at least 95% power to demonstrate that the change in hFVIII activity during Weeks 49-52 from baseline is greater than 0, assuming an effect size of 0.6, using a one-sample t-test with a 2-sided significance level of 0.05. The effect size of 0.6 is assumed based on Study 270-201 data. In Study 270-201 cohort 6E13, the mean (SD) of FVIII activity (IU/dL) at Week 52 (based on median values in a 4-week window around Week 52) were estimated as 103.8 (62.4), with a 95% confidence interval for the mean of (46.1, 161.5). Using the lower limit of the confidence interval and assuming a baseline value of 1 (the largest value allowed per the study's inclusion/exclusion criteria), the effect size of change from baseline is approximately 0.7. For the sample size calculation, an effect size of 0.6 is assumed.**

For the secondary endpoints, the analysis will be performed utilizing exogenous FVIII use and bleeding episode data from the 110 subjects whose baseline data will be prospectively collected for approximately 6 months in the non-interventional study 270-902, prior to their enrollment in Study 270-301. **An analytic sample size of 110 will provide at least 95% power to demonstrate that the change in the annualized utilization (IU/kg) of exogenous FVIII replacement therapy in the efficacy evaluation period ("Week 5 to Last Visit") from the baseline is less than 0, assuming an effect size of 0.6 conservatively, using one-sample t-test with a 2-sided significance level of 0.05.**

For the analytic sample size calculation of the second-ranked secondary endpoint, ABR, it is assumed that the pre- and post-BMN 270 infusion population mean ABRs are 3.5 and 1 respectively, and the distribution of ABRs is negative binomial distribution with a dispersion parameter of 2.2. Given the underlying negative binomial distributions, the standard deviations of the pre- and post-BMN 270 infusion ABRs are calculated as 7.8 and 1.8 respectively. **The mean (SD) of the change from the pre- to post-BMN 270 infusion ABRs are calculated as -2.5 (8) assuming the correlation between pre- and post-BMN 270**

infusion ABRs is zero. Under this assumption, an analytic sample size of 110 will also have at least 95% power to demonstrate that the change in the annualized number of bleeding episodes requiring exogenous FVIII replacement treatment (ABR) in the efficacy evaluation period (“Week 5 to Last Visit”) from the baseline ABR is less than 3.5 (non-inferiority margin), using a one-sample t-test with a 2-sided significance level of 0.05. Under the same assumptions, a sample size of 110 will have approximately 90% power to demonstrate that the change is less than 0, ie, superiority of BMN 270 against FVIII prophylaxis.

Overall, the planned sample size will have greater than 80% power for testing the primary and secondary efficacy endpoints hierarchically at the 1-year analysis with a 2-sided significance level of 0.05.

#### 14.9 Analysis Populations

The intention-to-treat (ITT) population is defined as all subjects who receive BMN 270 infusion, and the modified intention-to-treat (mITT) population is defined as subjects who receive BMN 270 infusion and are HIV-negative. The mITT population will be used for the primary efficacy analysis and ITT will be used for the supportive efficacy analysis. The ITT population will also be used for the safety analysis.

#### 14.10 Changes in the Conduct of the Study or Planned Analyses

Only BioMarin may modify the protocol. Any change in study conduct considered necessary by the Investigator will be made only after consultation with BioMarin, who will then issue a formal protocol amendment to implement the change. The only exception is when an Investigator considers that a subject’s safety is compromised without immediate action. In these circumstances, immediate approval of the chairman of the IRB/IEC/REB must be sought, and the Investigator should inform BioMarin and the full IRB/IEC/REB within 2 working days after the emergency occurs.

With the exception of minor administrative or typographical changes, the IRB/IEC/REB must review and approve all protocol amendments. Protocol amendments that have an impact on subject risk or the study objectives, or require revision of the ICF, must receive approval from the IRB/IEC/REB prior to their implementation.

When a protocol amendment substantially alters the study design or the potential risks or burden to subjects, the ICF will be amended and approved by BioMarin and the IRB/IEC/REB, and all active subjects must again provide informed consent.

If discrepancies exist in statistical methods between the SAP and the study protocol, the SAP will prevail.

## 15 DATA MONITORING COMMITTEE

An independent DMC will be convened for this study. The duties of the DMC will include:

- Conducting an ongoing review of individual subject safety and efficacy data during the study.
- **Recommending whether to enroll subjects at a different dose level (not to exceed 6E13 vg/kg) based on emerging data from 270-301 and the overall risk/benefit analysis of BMN 270.**
- Reviewing ongoing safety and efficacy data for comparability of drug manufacturing lots within 270-301 and between 270-201 and 270-301.
- **Making other** recommendations on the conduct and reporting of the trial based on their evaluation of clinical data.

**Details on the composition of the committee, frequency of meetings, and other committee functions and parameters are included in the DMC Charter and in the Statistical Analysis Plan (SAP).**

## 16 COSTS, COMPENSATION, AND SUBJECT INJURY

BioMarin will pay the full costs of the study-related tests, procedures, and treatments set forth in this protocol. In addition, after IRB/IEC/REB approval, BioMarin may reimburse the reasonable cost of travel for study-related visits in accordance with BioMarin's travel and reimbursement policy.

The Investigator should contact BioMarin immediately upon notification that a study subject has been injured by the study drug or by procedures performed as part of the study. Any subject who experiences a study-related injury should be instructed by the Investigator to seek immediate medical treatment at a pre-specified medical institution if possible, or at the closest medical treatment facility if necessary. The subject should be given the name of a person to contact to seek further information about, and assistance with, treatment for study-related injuries. BioMarin or the institution may pay for reasonable and necessary medical services to treat the injuries caused by the study drug or study procedures. In some jurisdictions, BioMarin is obligated by law to pay for study-related injuries. If this is the case, BioMarin will comply with the law. BioMarin will not pay for any hospitalizations, tests, or treatments for medical problems of any sort related solely to the study subject's primary disease or any concurrent disease and that are unrelated to this study.

## 17 CASE REPORT FORMS AND SOURCE DOCUMENTS

Electronic case report forms will be provided for each subject. The Investigator must review **and electronically sign the completed eCRF casebook to verify its accuracy.**

eCRFs must be completed using a web-based application developed and validated. Study site personnel will be trained on the application and will enter the clinical data from source **documentation. Unless explicitly allowed in the eCRF instructions, blank data fields are not** acceptable.

In the event of an entry error, or if new information becomes available, the value will be corrected by deselecting the erroneous response and then selecting or entering the factual **response. In compliance with ICH GCP Guidelines and 21 CFR Part 11, the system will require the personnel making the correction to enter a reason for changing the value.**

The documented audit trail will include the reason for the change, the original value, the new value, the time of the correction and the identity of the operator.

BioMarin's policy is that study data on the eCRFs must be verifiable to the source data, which necessitates access to all original recordings, laboratory reports, and subject records. **In addition, all source data should be attributable (signed and dated). The Investigator must** therefore agree to allow direct access to all source data. Subjects must also allow access to their medical records, and subjects will be informed of this and will confirm their agreement when giving informed consent. If direct source document verification of study data by the site monitor is prohibited by institutional policy or **local law, then the Investigator must make available facilities and/or personnel to allow GCP-compliant source verification to occur.** Examples of such methods include certified copies of records which have study data visible but sensitive information redacted, or other GCP-compliant means agreed between the Investigator and the Sponsor.

A site monitor designated by BioMarin will compare the eCRFs with the original source documents at the study site and evaluate them for completeness and accuracy before **designating them as "Source Data Verified" (SDV). If an error is discovered at any time or a clarification is needed, the site monitor, or designee, will create an electronic query on the associated field. Site personnel will then answer the query by either** correcting the data or **responding to the query. The site monitor will then review the response and determine either to close the query or re-query the site if the response does not fully address the question. This process is repeated until all open queries** have been answered and closed.

**Before a subject's eCRF casebook can be locked, data fields must be source data verified and all queries closed. Refer to the Study Monitoring Plan for details on which fields must be**

source data verified. The Investigator **will then electronically sign the casebook, specifying** that the information on the eCRFs is accurate and complete. The Data Manager, or designee, **will then set the status of the forms, visits, and the entire casebook to Locked.** Upon completion of the CSR, **an electronic copy of each site's casebooks will be copied to a compact disk (CD) and sent to each site for retention with other study documents.**

## 18 STUDY MONITORING AND AUDITING

Qualified individuals designated by BioMarin will monitor all aspects of the study according to GCP and standard operating procedures for compliance with applicable government regulations. The Investigator agrees to allow these monitors direct access to the clinical supplies, dispensing, and storage areas and to the clinical files, including original medical **records, of the study subjects, and, if requested, agrees to assist the monitors.**

The Investigator and staff are responsible for being present or available for consultation during routinely scheduled site visits conducted by BioMarin or its designees. When in person site monitoring or source data verification cannot be conducted, remote site **monitoring and/or source data verification will be conducted where allowed by country and local health authorities and ECs/IRBs.**

Members of BioMarin's GCP Compliance Department or designees may conduct an audit of a clinical site at any time before, during, or after completion of the study. The Investigator **will be informed if an audit is to take place and advised as to the scope of the audit.**

Representatives of the FDA or other Regulatory Agencies may also conduct an audit of the study. If informed of such an inspection, the Investigator should notify BioMarin immediately. The Investigator will ensure that the auditors have access to the clinical supplies, study site facilities, original source documentation, and all study files.



## 19 RETENTION OF RECORDS

**The Investigator must retain all study records required by BioMarin and by the applicable regulations in a secure and safe facility. The Investigator must consult a BioMarin representative before disposal of any study records, and must notify BioMarin of any change in the location, disposition or custody of the study files. The Investigator /institution must take measures to prevent accidental or premature destruction of essential documents, that is, documents that individually and collectively permit evaluation of the conduct of a study and the quality of the data produced, including paper copies of study records (eg, subject charts) as well as any original source documents that are electronic as required by applicable regulatory requirements.**

**All study records must be retained for at least 2 years after the last approval of a marketing application in the US or an ICH region and until (1) there are no pending or contemplated marketing applications in the U.S. or an ICH region or (2) at least 2 years have elapsed since the formal discontinuation of clinical development of the IP. The Investigator /institution should retain subject identifiers for at least 15 years after the completion or discontinuation of the study. Subject files and other source data must be kept for the maximum period of time permitted by the hospital, institution or private practice, but not less than 15 years.**

**These documents should be retained for a longer period, however, if required by the applicable regulatory requirements or by a BioMarin agreement. BioMarin must be notified and will assist with retention should Investigator /institution be unable to continue maintenance of subject files for the full 15 years. It is the responsibility of BioMarin to inform the Investigator /institution as to when these documents no longer need to be retained.**

## 20 USE OF INFORMATION AND PUBLICATION

BioMarin recognizes the importance of communicating medical study data and therefore encourages the publication of these data in reputable, peer-reviewed scientific journals and at seminars or conferences. The details of the processes of producing and reviewing reports, manuscripts, and presentations based on the data from this study will be described in the **Clinical Trial Agreement between BioMarin and the Investigator/Institution. Consideration for authorship of all publications will be based on compliance with the Uniform Requirements for Manuscripts Submitted to Biomedical Journals (“Uniform Requirements”) of the International Committee of Medical Journal Editors (ICMJE) ([http://www.icmje.org/ethical\\_1author.html](http://www.icmje.org/ethical_1author.html)) and good publication practices (GPP).**

## 21 REFERENCES

**Batts KP & Ludwig J. Chronic hepatitis: an update on terminology and reporting. Am J Surg Pathol 19:1409-1417. 1995.**

Bedossa P, Pynard T, French METAVIR Cooperative Study Group. An algorithm for **grading activity in chronic hepatitis C. Hepatology 24;289-293. 1996.**

Berntorp E, Dolan G, Hay C, Linari S et al. European retrospective study of real-life **haemophilia treatment. Haemophilia. 2017;23(1):105-114.**

**Berntorp E, Peake I, Budde U, Laffan M et. al. von Willebrand's disease: a report from a meeting in the Aland islands. Haemophilia 18 Suppl 6, 1-13. 2012.**

**Brooks R. EuroQol: the current state of play. Health Policy. 1996;37:53-72.**

**Chai-Adisaksopha C, Skinner M, Curtis R, et al. Psychometric Properties of the Patient Reported Outcomes, Burdens and Experiences (PROBE) Questionnaire. Blood. 2017;130:5645.**

EuroQol Group. EuroQol – a new facility for the measurement of health-**related quality of life. Health Policy. 1990;16:199-208.**

**George LA, Sullivan S, Teitel J, Cuker A et al. Preliminary results of a phase 1/2 trial of SPK-9001, a hyperactive FIX variant delivered by a novel capsid, demonstrate consistent factor IX activity levels at the lowest dose cohort. Haemophilia. 2016;22(S4):151-152.**

Grant A, Neuberger J, Day C, Saxseena S. British Society of Gastroenterology Guidelines on **the use of Liver Biopsy in Clinical Practice. 2004. Available at: <https://www.bsg.org.uk/resource/bsg-guidelines-on-the-use-of-liver-biopsy-in-clinical-practice.html> (last visited 20 January 2020).**

Hay CR, DiMichele DM. The principal results of the International Immune Tolerance Study: a randomized dose comparison  
**12. Blood 119[6], 1335-1344. 2012.**

Haemo-QoL Study Group. **Scoring Manual. Available at: <http://haemoqol.de/scoring/manual>. Last accessed 17 May 2021.**

**Iorio A, Stonebraker JS, Chambost H, et al, for the Data and Demographics Committee of the World Federation of Hemophilia. Establishing the Prevalence and Prevalence at Birth of Hemophilia in Males: A Meta-analytic Approach Using National Registries. Ann Intern Med. 2019;171(8):540-546.**

**Kaufman RJ, Powell JS. Molecular approaches for improved clotting factors for hemophilia 1. Blood 122[22], 3568-3574. 2013.**

Manno CS, Pierce GF, Arruda VR, Glader B et. al. Successful transduction of liver in hemophilia by AAV-Factor IX and limitations imposed by the host immune response. *Nat Med* 12[3], 342-347. 2006.

**Mieshach W, Tangelder M, Klamroth R, Schutgens R et al. Updated results from a dose escalating study in adult patients with haemophilia B with AMT-060 (AAV5-hFIX) gene therapy. Haemophilia 22[Suppl. 4], 151-152. 2016.**

**Mingozzi F and High KA. Immune responses to AAV vectors: overcoming barriers to successful gene therapy. Blood 122[1], 23-36. 2013.**

**National Center for Biotechnology Information (NCBI). LiverTox: Clinical and Research Information on Drug-Induced Liver Injury. Available at: <https://livertox.nih.gov> (last accessed 14 January 2020).**

**Nathwani AC, Reiss UM, Tuddenham EG, Rosales C et. al. Long-term safety and efficacy of factor IX gene therapy in hemophilia B. N Engl J Med 371[21], 1994-2004. 2014.**

Nathwani AC, Rosales, C, McIntosh J, Rastegarlarlari G et. al. Long-term safety and efficacy following systemic administration of a self-complementary AAV vector encoding human FIX pseudotyped with serotype 5 and 8 capsid proteins. *Mol Ther* 19[5], 876-885. 2011.

**Pasi KJ, Rangarajan S, Mitchell N, Lester W et al. Multiyear Follow-up of AAV5-hFVIII-SQ Gene Therapy for Hemophilia A. N Engl J Med. 2020;382(1):29-40.**

**Rangarajan S, Kim B, Lester W et al. Achievement of normal factor VIII activity following gene transfer with valoctocogene roxaparvovec (BMN 270): Long-term efficacy and safety results in patients with severe hemophilia A. Haemophilia 24[Suppl. 5], 65. 2018**

Reilly M. WPAI Scoring. 2002. Available at: [http://www.reillyassociates.net/WPAI\\_Scoring.html](http://www.reillyassociates.net/WPAI_Scoring.html). Last accessed 17 May 2021.

Recht M, Neufeld EJ, Sharma VR, Solem CT et al. Impact of Acute Bleeding on Daily Activities of Patients with Congenital Hemophilia with Inhibitors and Their Caregivers and Families: Observations from the Dosing Observational Study in Hemophilia (DOSE). *Value in Health*. 2014;17:744-748.

Rentz A, Flood E, Altisent C, Bullinger M et al. Cross-cultural development and psychometric evaluation of a patient-reported health-related quality of life questionnaire for adults with haemophilia. *Haemophilia* 2008;14(5):1023-34.

Sampson HA, Muñoz-Furlong A, Campbell RL, et al. Second symposium on the definition and management of anaphylaxis: summary report—second National Institute of Allergy and Infectious Disease/Food Allergy and Anaphylaxis Network symposium. *J Allergy Clin Immunol* 2006;117:391-397.

Srivastava A, Santagostino E, Dougall A, Kitchen S et. al. WFH guidelines for the management of hemophilia, 3rd edition. *Haemophilia*. 2020;26(Suppl 6):1-158.

Stonebraker JS, Brooker M, Amand RE, Farrugia A et. al. A study of reported factor VIII use around the world. *Haemophilia* 16[1], 33-46. 2010.

United States Department of Health and Human Services. Panel on Antiretroviral Guidelines for Adults and Adolescents. *Guidelines for the Use of Antiretroviral Agents in Adults and Adolescents with HIV*. 2019. Available at: <http://www.aidsinfo.nih.gov/ContentFiles/AdultandAdolescentGL.pdf> (last accessed 17 May 2021).

Van Genderen FR, Westers P, Heijnen L, De Kleijn P et al. **Measuring patients' perceptions on their functional abilities: validation of the Haemophilia Activities List.** *Haemophilia*. 2006;12:36-46.

Wiens BL, Dmitrienko A. **The fallback procedure for evaluating a single family of hypotheses.** *J Biopharm Stat.* 2005; 15:929–942.

## 22 INVESTIGATOR RESPONSIBILITIES

### 22.1 Conduct of Study and Protection of Human Patients

In accordance with FDA Form 1572 and/or principles of ICH E6 GCP, the Investigator will ensure that:

- He or she will conduct the study in accordance with the relevant, current protocol and **will only make changes in a protocol after notifying the sponsor, except when necessary to protect the safety, rights, or welfare of subjects.**
- He or she will personally conduct or supervise the study.
- He or she will inform any potential subjects, or any persons used as controls, that the drugs are being used for investigational purposes, and he or she will ensure that the **requirements relating to obtaining informed consent in 21 CFR Part 50 and/or ICH E6 sections 2.9 and 4.8 are met. As well, he or she will ensure that IRB/IEC review and approval in 21 CFR Part 56 and/or ICH E6 section 2.6 are met.**
- He or she will report to the sponsor adverse experiences that occur in the course of the **investigation in accordance with 21 CFR 312.64 and/or ICH E6 Section 4.11.**
- He or she has read and understands the information in the Investigator's Brochure, **including potential risks and side effects of the drug.**
- His or her staff and all persons who assist in the conduct of the study are informed about their obligations in meeting the above commitments
- **Adequate and accurate records in accordance with 21 CFR 312.62 and/or ICH E6 section 4.9 are kept, and those records are available for inspection in accordance with 21 CFR 312.68 and/or ICH E6 section 4.9.7.**
- **The IRB/EC/REB complies with the requirements of 21 CFR Part 56, ICH E6 Section 3.0, and other applicable regulations, and conducts initial and ongoing reviews and approvals of the study. He or she will also ensure that any change in research activity and all problems involving risks to human subjects or others are reported to the IRB/EC/REB. Additionally, he or she will not make any changes in the research without IRB/EC/REB approval, except where necessary to eliminate apparent immediate hazards to human subjects.**
- **He or she agrees to comply with all other requirements regarding the obligations of clinical Investigators and all other pertinent requirements in 21 CFR Part 312 and/or ICH E6.**

**23 SIGNATURE PAGE**

**Protocol Title:** A Phase 3 Open-Label, Single Arm Study To Evaluate The Efficacy and Safety of BMN 270, an Adeno-Associated Virus Vector–Mediated Gene Transfer of Human **Factor VIII in Hemophilia A Patients with Residual FVIII Levels ≤ 1 IU/dL** Receiving Prophylactic FVIII Infusions

**Protocol Number:** 270-301 Amendment 7 (United States-Specific)

I have read the forgoing protocol and agree to conduct this study as outlined. I agree to conduct the study in compliance with all applicable regulations and guidelines, including **ICH E6, as stated in the protocol, and other information supplied to me.**

\_\_\_\_\_  
Investigator Signature Date

Printed name: \_\_\_\_\_

**Accepted for the Sponsor:**

DocuSigned by:  
PI  
Signer Name: PI  
Signing Reason: I approve this document  
Signing Time: 20-Jul-2021 | 7:53 AM PDT  
834DEBF504AB4E8A83363FE5BE4B8D5F

\_\_\_\_\_  
Medical Monitor Signature Date

Printed name: PI MD, PhD, PI, Clinical Sciences



## 24 APPENDIX 1: SAMPSON'S ANAPHYLAXIS CRITERIA

According to the National Institute of Allergy and Infectious Disease/Food Allergy and Anaphylaxis Network (NIAID/FAAN) Second Symposium on the definition and management of anaphylaxis, anaphylaxis is highly likely when **any one** of the following 3 criteria are fulfilled:

1. **Acute onset of an illness (minutes to several hours) with involvement of the skin, mucosal tissue, or both (eg, generalized hives, pruritus or flushing, swollen lips-tongue-uvula)**  
*AND AT LEAST ONE OF THE FOLLOWING*
  - a. **Respiratory compromise (eg, dyspnea, wheeze-bronchospasm, stridor, reduced peak expiratory flow [PEF], hypoxemia)**
  - b. **Reduced blood pressure (BP) or associated symptoms of end-organ dysfunction (eg, hypotonia [collapse], syncope, incontinence)**
2. **Two or more of the following that occur rapidly after exposure to a likely allergen for that patient (minutes to several hours):**
  - a. **Involvement of the skin-mucosal tissue (eg, generalized hives, itch-flush, swollen lips-tongue-uvula)**
  - b. **Respiratory compromise (eg, dyspnea, wheeze-bronchospasm, stridor, reduced PEF, hypoxemia)**
  - c. **Reduced BP or associated symptoms (eg, hypotonia [collapse], syncope, incontinence)**
  - d. **Persistent gastrointestinal symptoms (eg, crampy abdominal pain, vomiting)**
3. **Reduced BP after exposure to known allergen for that patient (minutes to several hours):**
  - a. **Infants and children: low systolic blood pressure (age specific) or greater than 30% decrease in systolic BP**
  - b. **Adults: systolic BP of less than 90 mmHg or greater than 30% decrease from that person's baseline.**

Source: [Sampson 2006](#).



## 25 APPENDIX 2: REGION-SPECIFIC STUDY OBJECTIVES, ENDPOINTS, AND ANALYSES (“2-YEAR ANALYSIS”) FOR THE UNITED STATES

**For the regulatory submission of the BLA for BMN 270, the US FDA has requested BioMarin to submit 2-year safety and efficacy data on all subjects in 270-301, with ABR being the primary efficacy endpoint. This section specifies region-specific study objectives and the associated endpoints and analyses to achieve them in order to fulfill this regulatory requirement. The analysis (“2-year analysis”) will be performed after all subjects have completed the Week 104 visit or have withdrawn from the study.**

This 2-year analysis does not affect the study sample size, study conduct, and data collection.

### 25.1 Region-Specific Study Objectives

- Primary efficacy objective
  - **To assess the impact of BMN 270 (compared to FVIII prophylaxis) on the number of bleeding episodes requiring exogenous FVIII replacement therapy in the efficacy evaluation period (from Week 5 to last visit by the data cut-off for the 2-year analysis following intravenous infusion of BMN 270, hereafter in Appendix 2 referred to as “Week 5 to Last Visit”)**
- Secondary efficacy objectives
  - **To assess the efficacy of BMN 270 (compared to no treatment) defined as FVIII activity, as measured by chromogenic substrate assay, at Week 104 following intravenous infusion of BMN 270**
  - **To assess the impact of BMN 270 (compared to FVIII prophylaxis) on usage of exogenous FVIII replacement therapy in the efficacy evaluation period (“Week 5 to Last Visit”)**
- Tertiary efficacy objective
  - **To assess the impact of BMN 270 (compared to FVIII prophylaxis) on patient-reported outcomes (PROs) at Week 104 following intravenous infusion of BMN 270**
- Safety objectives
  - **To evaluate the safety of BMN 270 during the first 52 weeks following intravenous infusion of BMN 270**
  - To assess the long-term safety of BMN 270

- Exploratory objectives of the liver biopsy substudy
  - To examine the histopathology of the liver following BMN 270 therapy, **including assessing for possible safety findings (eg, fibrosis, fatty liver disease, lymphocytic invasion)**
  - **To quantify FVIII DNA, RNA, and protein expression within hepatocytes**
  - To determine which forms of rAAV vector DNA are present at the time of biopsy
  - To determine the distribution of BMN270-transduced hepatocytes in **human liver (ie, peri-portal hepatocytes, central vein hepatocytes)**

## 25.2 Region-Specific Study Endpoints

- Primary efficacy endpoint
  - **Change from baseline (prior to BMN 270 infusion while receiving FVIII prophylaxis) in the annualized number of bleeding episodes requiring exogenous FVIII replacement treatment (annualized bleeding rate, ABR) in the efficacy evaluation period (“Week 5 to Last Visit”)**
- Secondary efficacy endpoints
  - **Change from baseline (assuming no treatment for severe hemophilia A) in FVIII activity, as measured by chromogenic substrate assay, at Week 104 post-BMN 270 infusion**
  - **Change from baseline (prior to BMN 270 infusion while receiving FVIII prophylaxis) in the annualized utilization (IU/kg/year) of exogenous FVIII replacement therapy in the efficacy evaluation period (“Week 5 to Last Visit”)**
- Tertiary efficacy endpoints
  - Change from baseline in the total score of Haemo-QoL- **A at Week 104** of the study post-BMN 270 infusion
  - Change from baseline in the EQ-5D- **5L score at Week 104** of the study post-BMN 270 infusion
  - **Change from baseline in the HAL score at Week 104** of the study post-BMN 270 infusion
  - **Change from baseline in the WPAI+CIQ:HS score at Week 104** of the study post-BMN 270 infusion
  - Change from baseline in **PROBE score at Week 104** of the study post-BMN 270 infusion

- Safety endpoints
  - Incidence of AEs and SAEs
  - **Change in clinical laboratory tests (serum chemistry and hematology)**
  - Change in vital signs
  - Change in physical examination
  - **Vector shedding (blood, urine, semen, stool, saliva)**
  - **Liver tests (LTs, including ALT, AST, GGT, direct and total bilirubin, LDH, and alkaline phosphatase)**
  - Immune response to FVIII transgene product and AAV5 capsid proteins

### 25.3 Statistical Methods for the Analysis of Region-Specific Endpoints

#### 25.3.1 Statistical Analysis Plan

**The study protocol outlines the planned primary analysis for the key efficacy and safety endpoints of the 2-year analysis. A statistical analysis plan (SAP) will be created to provide additional details on these analyses, as well as the planned supportive, sensitivity, and subgroup analyses and analyses for the other endpoints.**

If discrepancies exist in statistical methods between the SAP and the study protocol, the SAP will prevail.

#### 25.3.2 Timing of Analysis

**The 2-year analysis will be performed after all subjects have completed the Week 104 visit or have withdrawn from the study. The data cutoff date for this analysis (“analysis data cutoff date”) will be approximately 15 November 2021, two years after the last enrolled subject was dosed with BMN 270.**

#### 25.3.3 Data to be Included in the Analysis

All safety and efficacy data through each subject’s last visit up to the analysis data cutoff date will be included in the analysis.

#### 25.3.4 Analysis Populations

Subjects will be analyzed in the following analysis populations:

- **Intent-to-Treat (ITT) Population: all** subjects who received BMN 270 infusion in 270-301.
- **Modified Intent-to-Treat (mITT) Population: subjects who received BMN 270** infusion in 270-301 **and were HIV-negative** at study screening.

- **Study 270-902 Rollover Subjects:** subjects who completed approximately 6 months' participation in the BioMarin-sponsored non-interventional study 270-902 before enrolling in 270-301, were HIV-negative at study screening, and received BMN 270 infusion in 270-301.
- **Directly Enrolled Subjects:** subjects who were enrolled in 270-301 without prior participation in 270-902 and received BMN 270 infusion in 270-301.
- **Directly Enrolled, HIV-Negative Subjects:** subjects who were directly enrolled in 270-301 and were HIV-negative at study screening.

The 270-902 rollover subjects will be used for the primary analysis of the primary efficacy endpoint (ABR) and the second-ranked secondary efficacy endpoint (annualized FVIII utilization), the mITT population will be used for the primary analysis of the first-ranked secondary efficacy endpoint (FVIII activity), and the ITT population will be used for the primary analysis of safety.

### 25.3.5 Interim Analyses and Control of Type I Error Rate

Prior to this 2-year analysis, two protocol-specified interim analyses and a 1-year analysis were planned, of which one interim analysis and the 1-year analysis were performed.

Two interim analyses were planned after approximately 16 and 20 treated HIV-negative subjects have completed the Week 26 visit (or have discontinued study prior to Week 26), respectively. The concept of the interim analyses was to facilitate initiation of regulatory review of the ongoing study in the event that robust improvements (essentially normalization) in FVIII activity in a sufficient proportion of the subjects are observed. The primary efficacy endpoint was subject's FVIII response status, where a subject was considered as a responder if the median FVIII activity per chromogenic assay during Weeks 23-26 post-BMN 270 infusion is  $\geq 40$  IU/dL. The alpha levels of 0.0002 and 0.001 were allocated to the first and second interim analysis, respectively. The second interim analysis would only occur if the result from the first interim analysis was not positive (ie, if the pre-specified statistical significance was not achieved). A 1-year analysis was planned after all subjects have been followed for 52 weeks post-BMN 270 infusion (or have discontinued study prior to Week 52). The efficacy endpoints included change from baseline (prior to BMN 270 infusion while receiving FVIII prophylaxis) in ABR for treated bleeds, change from baseline (assuming no treatment for severe hemophilia A) in FVIII activity per chromogenic assay at Weeks 49-52, and change from baseline (prior to BMN 270 infusion while receiving FVIII prophylaxis) in annualized FVIII utilization. These endpoints were tested sequentially using a hierarchical testing procedure at the alpha level determined by the fallback procedure (Wiens 2005) to control the family-wise type I error rate at 0.05. Results

from this analysis were intended to support regulatory submissions to EMA and other health authorities outside of FDA.

**The first interim analysis was performed in May 2019 (data cut-off date: 30 April 2019) after 16 directly enrolled, HIV-negative subjects have completed the Week 26 visit. Based on the analysis results ( $p=0.001$ ) and the totality of the data, the secondary interim analysis was deemed unnecessary (the test would be statistically significant at the pre-specified significance level of 0.001) and therefore never implemented. The 1-year analysis was performed in January 2021 (data cut-off date: 16 November 2020) after all subjects had been followed for 52 weeks post-BMN 270 infusion. Results from all pre-specified tests were statistically significant ( $p < 0.0001$ ) at the alpha level of 0.0498 that was determined by the fallback procedure.**

- If the first interim p-value  $\leq 0.0002$ , the first interim result is declared significant and the 1-year analysis is carried out at the 0.05 level.
- If the first interim p-value  $> 0.0002$ , the first interim result is not declared significant and the second interim analysis is carried out at 0.001 level. If the second interim p-value  $\leq 0.001$ , the second interim result is declared significant and the 1-year analysis is carried out at the 0.0498 level.
- If the second interim p-value  $> 0.001$ , the interim results are not declared significant and the 1-year analysis is carried out at the 0.0488 level.

**As specified in the 1-year analysis SAP (version 3.0, dated 17 December 2020), in the event that a 2-year final analysis is necessary, the testing procedure used in the 1-year analysis will be extended to the 2-year final analysis. That is, when all pre-specified tests are statistically significant at the 1-year analysis, the corresponding efficacy endpoints at 2 years will be tested in the same sequence under the same significance level.**

**Based on the fallback procedure and positive results from the 1-year analysis, the 2-year final analysis will be performed at the significance level of 0.0498 and the efficacy endpoints will be tested in the following hierarchical testing sequence:**

1. For non-inferiority of BMN 270 versus FVIII prophylaxis in ABR with a NI margin of 3.5  
Null hypothesis: post-baseline ABR – **baseline ABR  $\geq 3.5$**
2. For superiority of BMN 270 versus no treatment for severe hemophilia A in FVIII activity  
Null hypothesis: FVIII activity at Week 104 – **baseline FVIII activity  $\leq 0$**
3. For superiority of BMN 270 versus FVIII prophylaxis in FVIII utilization  
Null hypothesis: post-baseline FVIII utilization – **baseline FVIII utilization  $\geq 0$**

4. For superiority of BMN 270 versus FVIII prophylaxis in ABR

Null hypothesis: post-baseline ABR – **baseline ABR  $\geq 0$**

After the 2-year final analysis, safety and efficacy will then continue to be assessed long-term in all subjects for a total of approximately 5 years.

### 25.3.6 Analysis Methods

#### Primary Efficacy Endpoint

The primary efficacy endpoint is change from baseline in ABR for treated bleeds.

The primary analysis of the primary efficacy endpoint will be based on the 270-902 Rollover Subjects. The baseline ABR under FVIII prophylaxis will be based on the data collected in 270-902. **The ABR post-BMN 270 infusion will be based the data collected in the efficacy evaluation period, defined as Week 5 to each subject's last visit up to the analysis data cutoff date.**

Change from baseline in ABR will first be tested for non-inferiority with a NI margin of 3.5 using the confidence interval approach. Assuming a t distribution, the **2-sided 95% confidence interval (CI) will be constructed for the mean change (post-baseline - baseline) in ABR.** If the upper bound of the CI is less than 3.5, the non-inferiority of BMN 270 versus FVIII prophylaxis in ABR with this margin will be declared.

If non-inferiority is demonstrated, non-inferiority with smaller margins and superiority will be assessed using the same CI. The 2-sided p-value for superiority will be obtained through a one-sample t-test to test the null hypothesis that the change is 0 or greater.

A Wilcoxon signed-**rank test and a negative binomial regress model will be used as** sensitivity analyses for testing superiority in ABR.

#### First-Ranked Secondary Efficacy Endpoint

The first-**ranked secondary efficacy endpoint is change from baseline in FVIII activity, as measured by chromogenic substrate assay, at Week 104 post-BMN 270 infusion.**

The primary analysis of the first-**ranked secondary efficacy endpoint will be based on the mITT population. The baseline FVIII activity value will be imputed as 1 IU/dL since there was no washout of severe hemophilia A subjects' usual FVIII prophylaxis (in order to avoid increasing the risk of bleeding) prior to BMN 270 infusion. FVIII activity values post-BMN 270 infusion will be excluded from analysis if obtained within 72 hours (or 3 calendar days if time is not available) following an exogenous FVIII infusion. To reduce variation caused by random fluctuation, FVIII activity will be analyzed as the median of observed values in the**



visit windows as defined in Section 20.1 of the 2-year analysis SAP. Missing data will be imputed as follows:

- Dropout missing
  - For subjects who discontinue from the study early, missing FVIII activity values post-**discontinuation will be imputed to be 0 IU/dL through the data cutoff date** for the analysis.
- Intermittent missing
  - **For subjects who continue on study, missing FVIII activity values (eg, due to a missed study visit) will be imputed to be the smaller of the last prior non-missing value and the next non-missing value.** In rare cases where the next value is unavailable for a subject who did not drop out, the missing value will be imputed through linear extrapolation using the last two prior non-missing values.

A one-sample t-test will be used to test the null hypothesis that the change in FVIII activity **from baseline to Week 104 (Week 104 - baseline) is 0 or less (ie, superiority when the null hypothesis is rejected). Summary of FVIII activity over time, including at Week 104, will be provided for descriptive purposes.**

A complete case **analysis (without missing data imputation), a mixed model for repeated measures (MMRM) approach, a last observation carried forward (LOCF) approach, and imputing missing data to be 0 IU/dL will be used as sensitivity analyses for testing superiority.**

Additional details about the sensitivity analyses as well as the missing data imputation will be provided in the 2-year analysis SAP.

#### Second-Ranked Secondary Efficacy Endpoint

The second-**ranked secondary efficacy endpoint is change from baseline in annualized utilization (IU/kg) of exogenous FVIII replacement therapy.**

The primary analysis of the second-**ranked secondary efficacy endpoint will be based on the 270-902 Rollover Subjects. The baseline FVIII utilization under FVIII prophylaxis will be based on the data collected in 270-902. The FVIII utilization post-BMN 270 infusion will be based the data collected in the efficacy evaluation period defined as Week 5 to each subject's last visit up to the analysis data cutoff date.**

A one-sample t-test will be used to test the null hypothesis that the change from baseline in **annualized FVIII utilization (post-baseline - baseline) is 0 or greater (ie, superiority when the null hypothesis is rejected). Change from baseline in annualized FVIII infusion rate (AFR**

**number of exogenous FVIII infusions/year) will be analyzed similarly for descriptive purposes.**

#### Safety Endpoints

Analysis of safety endpoints will be descriptive.

The incidence of AEs will be summarized by system organ class, preferred term, relationship to study drug, seriousness, and severity. A by-subject listing will be provided for subjects who experience a SAE, including death, or experience an AE associated with early withdrawal from the study. Clinical laboratory test values, vital signs, vector shedding and immune response parameters will be summarized descriptively by visit.

**Additional details on the primary analysis of the key efficacy and safety endpoints, as well as the planned supportive, sensitivity, and subgroup analyses and analyses for the other endpoints will be provided in the 2-year analysis SAP.**



## 26 PROTOCOL AMENDMENT TEXT REVISIONS

The following table summarizes the revisions made to the protocol and relates the changes to the appropriate rationale (see pages 2-4). Added text is indicated by underlined font and deleted text is indicated by ~~striketrough~~ font.

| Section No./Title                  | Revision  | Rationale       |
|------------------------------------|---|-----------------|
| 2/Synopsis (Study Rationale)       | <p>BMN 270 is being evaluated in clinical study 270-201, an ongoing first-in-human, phase 1/2 dose escalation study in subjects with severe HA designed to assess the safety and efficacy of BMN 270 at various dose levels (6E12 vg/kg, 2E13 vg/kg, 4E13 vg/kg, 6E13 vg/kg). Specifically, 270-201 explores the relationship of vector dose to the augmentation of residual FVIII activity and whether these levels are sufficient to alter the clinical phenotype. Preliminary Four-year results from 270-<del>201-201</del> and one-year results from 270-301 have demonstrated that following gene transfer, <u>mean and median FVIII activity levels above 15% (15 IU/dL) and, in many cases, within the normal range for FVIII, is, as measured by a chromogenic substrate assay, are achievable with a dose and sustained following a single infusion of 4-6E13 vg/kg of BMN 270, with an acceptable safety profile (Pasi, 2017).</u> Preliminary results from optional liver biopsies confirm dose-dependent pan-lobular and otherwise healthy liver transduction at 2.7-4.1 years.</p>   | 12              |
| 2/Synopsis (Objectives)            | <p>The secondary efficacy objectives of the study are to:</p> <ul style="list-style-type: none"> <li>Assess the impact of BMN 270 on usage of exogenous FVIII replacement therapy <del>from Week 5 to Week 52</del> <u>in the efficacy evaluation period (from Week 5 to last visit by the data cutoff for the 1-year analysis, hereafter referred to as “Week 5 to Last Visit”)</u></li> <li>Assess the impact of BMN 270 on the number of bleeding episodes requiring exogenous FVIII replacement therapy <del>from in the efficacy evaluation period (“Week 5 to Week 52 Last Visit”)</del></li> </ul> <p><u>The aforementioned study efficacy objectives were achieved through the pre-specified analysis at Week 52 (“1-year analysis”) for the study, which was performed in January 2021 after all subjects had been followed for 52 weeks post-BMN 270 infusion (data cutoff date: 16 November 2020). Results from this analysis are intended to support regulatory submissions to EMA and other health authorities outside of FDA.</u></p> <p><u>The FDA has requested BioMarin to submit 2-year safety and efficacy data on all subjects in 270-301 to enable their benefit-risk assessment of BMN 270. To fulfill this regulatory requirement, Appendix 2 has been created to specify region-specific study objectives for the United States and the associated endpoints and analyses to achieve them. This analysis (“2-year analysis”) will be performed after all subjects have completed the Week 104 visit or have withdrawn from the study.</u></p> | 3, 9            |
| 2/Synopsis (Study Design and Plan) | <p>The <u>final 1-year</u> analysis for the study <del>will be</del> <u>was</u> performed after all subjects <del>have had</del> <u>had</u> been followed for 52 weeks post-BMN 270 infusion. <u>A separate 2-year analysis will also be performed per request from the FDA after all subjects have been followed for 104 weeks post-BMN 270 infusion.</u> After the <del>final analysis</del> <u>1-year</u> and the 2-year analyses, safety and efficacy will then continue to be assessed long-term in all subjects for a total of approximately 5 years.</p>   | 3, 7, 9, 10, 12 |

| Section No./Title                    | Revision  | Rationale |
|--------------------------------------|---|-----------|
|                                      | <p>...</p> <p><b>Subjects who do not respond to BMN 270 treatment (ie, treatment failure, manifesting as either failure to achieve FVIII activity <math>\geq</math> 5 IU/dL by Week 52 or and inability to maintain independence from prophylactic FVIII replacement therapy due to joint bleeding episodes, in the judgment of the Investigator) may, at the Investigator's discretion and after discussion with the Medical Monitor or Sponsor-designated Data Monitor, follow an abbreviated visit schedule after Week 52 of the study by attending only the Q12W and End of Year visits during Years 2-5.</b></p> <p>...</p> <p>An optional liver biopsy will be performed as part of the liver biopsy substudy (in subjects who consent to do so) during Year 1 post-infusion, at or around Week 52, and/or during Years 2-5 following BMN 270 infusion. Subjects who consent to the liver biopsy will have additional assessments, including a liver ultrasound and FibroScan, and will receive prophylactic FVIII prior to the procedure, as if indicated in the judgment of the Investigator, to minimize the risk of bleeding. <u>Additional liver biopsies may be performed as part of the substudy during Years 2-5 as clinically indicated.</u></p>   |           |
| 2/Synopsis (Criteria for Evaluation) | <p>Secondary efficacy endpoints:</p> <ul style="list-style-type: none"> <li>• <b>Change in the annualized utilization (IU/kg) of exogenous FVIII replacement therapy during in the efficacy evaluation period (“Week 5 to <del>Week 52 post-BMN 270 infusion</del>Last Visit”)</b> from the baseline utilization of exogenous FVIII replacement therapy.</li> <li>• <b>Change in the annualized number of bleeding episodes requiring exogenous FVIII replacement treatment (annualized bleeding rate, ABR) during therapy in the efficacy evaluation period (“Week 5 to <del>Week 52 of the study post-BMN 270 infusion</del>Last Visit”)</b> from the baseline ABR.</li> </ul>  | 3         |
| 2/Synopsis (Statistical Methods)     | <p><u>Sample Size</u></p> <p>For the secondary endpoints, the analyses will be performed utilizing exogenous FVIII use and bleeding episode data from the 110 subjects whose baseline data will be prospectively collected for approximately 6 months in the non-interventional study 270-902, prior to their enrollment in 270-301. An analytic sample size of 110 will provide at least 95% power to demonstrate that the change in the annualized utilization (IU/kg) of exogenous FVIII replacement therapy during in the efficacy evaluation period (“Week 5 to <del>Week 52 post-BMN 270 infusion</del>Last Visit”) from baseline is less than 0, assuming an effect size of 0.6, using a one-sample t-test with a 2-sided significance level of 0.05.</p> <p>An analytic sample size of 110 will also have at least 95% power to demonstrate that the change in the annualized number of bleeding episodes requiring exogenous FVIII replacement treatment (ABR) during in the efficacy evaluation period (“Week 5 to <del>Week 52 of the study post-BMN 270 infusion</del>Last Visit”) from the baseline ABR is less than 3.5 (non-inferiority margin), assuming the pre- and post-BMN 270 infusion population mean ABRs are 3.5 and 1 respectively, using a one-sample t-test with a 2-sided significance level of 0.05. <b>Under the same assumptions, a sample</b></p> | 3, 9, 12  |

| Section No./Title            | Revision  | Rationale |
|------------------------------|---|-----------|
|                              | <p>size of 110 will have approximately 90% power to demonstrate that the change is less than 0, ie, superiority of BMN 270 against FVIII prophylaxis.</p> <p><u>Analysis</u></p> <p>For the first-<u>ranked</u> secondary efficacy endpoint <del>at Week 52 (ie, the change in the annualized utilization (IU/kg) of exogenous FVIII replacement therapy during Weeks in the efficacy evaluation period (“Week 5-52 post BMN 270 infusion from baseline), to Last Visit”)</del>, a one-sample t-test will be performed to test the null hypothesis that the change is 0 or greater against the alternative hypothesis that the change is less than 0.</p> <p>For the second-<u>ranked</u> secondary efficacy endpoint <del>at Week 52 (ie, the change in the annualized number of bleeding episodes requiring exogenous FVIII replacement treatment during Weeks 5-52 post BMN 270 infusion from baseline), in the efficacy evaluation period (“Week 5 to Last Visit”)</del>, a one-sample t-test will be performed to test for non-inferiority of BMN 270 against FVIII prophylaxis (ie, the baseline ABR calculated using subjects’ data collected in 270-902) using a margin of 3.5, ie, to test the null hypothesis that the change is 3.5 or greater against the alternative hypothesis that the change is less than 3.5. If non-inferiority is demonstrated, the test for superiority of BMN 270 against FVIII prophylaxis will be performed.</p> <p>...</p> <p>The fallback procedure will be used to adjust for multiplicity of the two interim analyses at Week 26, <del>and the final the 1-year analysis at Week 52, and the 2-year analysis at Week 104 (regardless of the interim analyses results, the study is planned to continue for a total of approximately 5 years upon the DMC’s recommendation, and the final analysis will be performed at Week 52).</del> At the <del>final</del> 1-year analysis at Week 52 and the 2-year analysis at Week 104, the secondary efficacy endpoints will be tested hierarchically; the level of significance will be determined by the fallback procedure.</p> |           |
| 7/Introduction               | Hemophilia A (HA) is an X-linked recessive bleeding disorder that affects approximately 1 in 5,000 males (Nathwani, 1992, <i>Baillieres Clin.Haematol.</i> ); Iorio 2019).  | 12        |
| 7.2/Ongoing Clinical Studies | <p><del>Study</del> Ongoing clinical studies for BMN 270 include:</p> <ul style="list-style-type: none"> <li>• <del>270-201 is an ongoing, a phase 1/2, dose-escalation study to assess the safety, tolerability, and efficacy of BMN 270 in patients with severe hemophilia A (HA</del></li> <li>• <del>270-203, a phase 2 study in patients with severe HA who have anti-AAV5 antibody titers</del></li> <li>• <del>270-205, a phase 1/2 study in patients with severe HA who have active or prior FVIII &lt;1 IU/dL). Subjects in</del>inhibitors</li> <li>• <del>270-302, a phase 3 study in patients with severe HA who receive BMN 270 at the 4E13 vg/kg dose level</del></li> <li>• <del>270-303, a phase 3 study in patients with severe HA who received a single BMN 270 infusion and are to be followed for safety and efficacy for up to 5 years. A total of 15 subjects have been enrolled at one of 4 dose levels (6E12, 2E13, 4E13, and at the 6E13 vg/kg). dose level along with prophylactic corticosteroids</del></li> </ul>   | 12        |

| Section No./Title                         | Revision  | Rationale |
|---|---|-----------|
| 7.3/Study Rationale                       | <p><del>Preliminary</del> Four-year results from 270-201 have demonstrated that following gene transfer, mean and median FVIII activity levels above 15% (15 IU/dL) and, in many cases, within the normal range for FVIII, is, as measured by a chromogenic substrate assay, are achievable with a dose and sustained following a single infusion of 4-6E13 vg/kg of BMN 270, with an acceptable safety profile (Pasi, 2017). <u>Preliminary results from optional liver biopsies (in subjects receiving lower doses of BMN 270 in 270-201) confirm dose-dependent pan-lobular and otherwise healthy liver transduction at 2.7-4.1 years.</u> For additional information on preliminary data in 270-201, refer to the current version of the Investigator's Brochure.</p>   | 12        |
| 7.4/Summary of Overall Risks and Benefits | <p><del>Transient, asymptomatic ALT elevation (grade 1 to 3 in severity) was observed in most subjects administered BMN 270 shortly after dosing, with no symptoms or sequelae suggestive of clinically significant hepatocyte injury or liver dysfunction. In almost all subjects, ALT elevations decreased quickly following corticosteroid treatment. There were differences in the use of corticosteroids across studies. Subjects in 270-201 received corticosteroids an average of 8 weeks earlier following BMN 270 infusion than the mITT population in 270-301, were more likely to avoid a significant decline in FVIII activity concurrently with an ALT elevation, and saw a more robust recovery of FVIII activity upon the first use of corticosteroids, than did the subjects in the mITT population in 270-301. Despite the clinical response to steroids, no associations between safety parameters (transient ALT rises), or efficacy as measured by FVIII activity levels were found to be temporally associated with anti-AAV5 antibody or cellular immune responses. Across the 6E13 vg/kg cohort of 270-201 and 270-301, subjects enrolled in 270-201 developed ALT elevation about 5.5 weeks later than subjects in 270-301, generally once the first course of corticosteroids was being tapered, and experienced lower peak elevations in ALT (75.7 U/L) than subjects in 270-301 (112.5 U/L). The difference in the ALT profile seen between the 6E13 vg/kg subjects in 270-201 and the subjects in 270-301 could be attributed to the difference in the protocol-specified corticosteroid regimens in place in those studies, including the early use of corticosteroids (ie, by Week 3 post-BMN 270 infusion). While the majority of ALT elevations responded rapidly to corticosteroids, given current interest in the field of AAV gene therapy for the use of non-steroidal approaches to managing or preventing ALT elevations, alternate non-steroidal systemic immunosuppressive agents have also been used to manage hepatic reactions where corticosteroids have proven to be ineffective or where high doses/and or prolonged exposure to corticosteroids have led to unwanted side effects. Overall, the literature and clinical experience with BMN 270 suggests that transient elevations in liver enzymes are expected following AAV-based gene therapy for the treatment for hemophilia A or B without any long-term concerns of hepatic injury (Manno 2006; Nathwani 2011; George 2016; Miesbach 2016; Pasi 2020).</del></p> <p>...</p> <p>In 270-301, an interim analysis has shown increased FVIII activity in the majority of subjects to mild HA or normal levels at 26 weeks post-infusion, also with markedly decreased bleeding compared with pre-study rates and the ability to discontinue prophylactic FVIII infusions. All subjects who <del>will be</del> were included in the <del>final</del> 1-year analysis have been dosed with 6E13 vg/kg and continue to be followed.</p> | 12        |

| Section No./Title                 | Revision  | Rationale       |
|-----------------------------------|---|-----------------|
| 8/Study Objectives                | <p>The secondary efficacy objectives of the study are to:</p> <ul style="list-style-type: none"> <li>Assess the impact of BMN 270 on usage of exogenous FVIII replacement therapy <del>from Week 5 to Week 52</del> <u>in the efficacy evaluation period (from Week 5 to last visit by the data cutoff for the 1-year analysis, hereafter referred to as “Week 5 to Last Visit”)</u></li> <li>Assess the impact of BMN 270 on the number of bleeding episodes requiring exogenous FVIII replacement therapy <del>from-in the efficacy evaluation period (“Week 5 to Week 52 Last Visit”)</del></li> </ul> <p><u>The aforementioned study efficacy objectives were achieved through the pre-specified analysis at Week 52 (“1-year analysis”) for the study, which was performed in January 2021 after all subjects had been followed for 52 weeks post-BMN 270 infusion (data cutoff date: 16 November 2020). Results from this analysis are intended to support regulatory submissions to EMA and other health authorities outside of FDA.</u></p> <p><u>The FDA has requested BioMarin to submit 2-year safety and efficacy data on all subjects in 270-301 to enable their benefit-risk assessment of BMN 270. To fulfill this regulatory requirement, Appendix 2 has been created to specify region-specific study objectives for the United States and the associated endpoints and analyses to achieve them. This analysis (“2-year analysis”) will be performed after all subjects have completed the Week 104 visit or have withdrawn from the study.</u></p>   | 3, 9            |
| 9.1/Overall Study Design and Plan | <p>The <del>final 1-year</del> analysis for the study <del>will be</del> <u>was</u> performed after all subjects <del>have had</del> been followed for 52 weeks post-BMN 270 infusion. A separate <u>2-year analysis will also be performed per request from the FDA after all subjects have been followed for 104 weeks post-BMN 270 infusion.</u> After the <del>final analysis</del> 1-year and the 2-year analyses, safety and efficacy will then continue to be assessed long-term in all subjects for a total of approximately 5 years.</p> <p>...</p> <p><u>Subjects who do not respond to BMN 270 treatment (ie, treatment failure, manifesting as either failure to achieve FVIII activity <math>\geq</math> 5 IU/dL by Week 52 <del>or</del> and inability to maintain independence from prophylactic FVIII replacement therapy due to joint bleeding episodes, in the judgment of the Investigator) may, at the Investigator’s discretion and after discussion with the Medical Monitor or Sponsor-designated Data Monitor, follow an abbreviated visit schedule after Week 52 of the study by attending only the Q12W and End of Year visits during Years 2-5.</u></p> <p>...</p> <p><u>An optional liver biopsy will be performed as part of the liver biopsy substudy (in subjects who consent to do so) during Year 1 post-infusion, at or around Week 52, and/or during Years 2-5 following BMN 270 infusion. Subjects who consent to the liver biopsy will have additional assessments, including a liver ultrasound and FibroScan, and will receive prophylactic FVIII prior to the procedure, as indicated in the judgment of the Investigator, to minimize the risk of bleeding. Additional liver biopsies may be performed as part of the substudy during Years 2-5 as clinically indicated.</u></p> | 3, 7, 9, 10, 12 |



| Section No./Title                          | Revision   | Rationale         |
|--|--|-------------------|
| Table 9.1.5/Schedule of Events (Years 2-5) | Table 9.1.5 has been updated consistent with changes in the table footnotes and elsewhere in the protocol.   | 1, 5, 6, 7, 8, 12 |
| Table 9.1.5 (footnotes)                    | <p><u>ETV: Early Termination Visit</u></p> <p><sup>a</sup> Complete physical examination should be performed at the End of Year visits; <b>(genitourinary examination may be deferred); brief physical exam may be performed at other study visits.</b> Weight should be recorded at the second Q12W visit each year and at every End of Year visit during Years 2-5.</p> <p><sup>b</sup> Refer to Table 9.7.8.2.1 for laboratory assessments to be included, and to Table 9.7.8.3.1 for liver tests. <del>LTs</del><u>LT assessment</u> may be <del>monitored</del><u>checked</u> more or less frequently <del>(and in particular when ALT values are &gt; ULN or ≥ 1.5x baseline value)</del> or based <del>on</del><u>upon</u> discussion between the Medical Monitor and the Investigator <del>and review of subject data, but LTs will be monitored at least twice weekly during periods when a subject's ALT is ≥ 3x ULN.</del> Subjects with ALT &gt; ULN or ≥ 1.5x baseline value during the study and either an alternative etiology considered or <b>for further evaluation of the lab abnormality may undergo additional evaluations (eg, imaging studies including MRI or ultrasound, additional blood tests, and/or liver biopsy) at the discretion of the Investigator. Additional testing of FVIII and LTs during any study week may be performed if: (1) the ALT has increased to above ULN or increased by &gt; 10 U/L from prior assessment; (2) increases in ALT values from prior assessment are accompanied by declines in FVIII activity level; or (2)</b> after a discussion between the Medical Monitor and the Investigator based on a review of subject data. <del>If FVIII levels and/or ALT values are stable over the course of several weeks, assessment of FVIII activity and ALT levels may be adjusted based on discussion between the Medical Monitor and the Investigator.</del> During Years 2-5 of the Post-Infusion Follow-Up period, <b>urine tests and blood, chemistry, and coagulation tests should be performed at the second Q12W visit each year and at every End of Year visit.</b></p> <p><sup>c</sup> <b>Includes FVIII activity level (chromogenic substrate FVIII assay and one-stage clotting FVIII assay), Bethesda assay (with Nijmegen modification) for hFVIII inhibitor level, and coagulation exploratory assay, and hFVIII protein assay.</b> If a subject has used FVIII within 72 hours of a measurement day, all efforts should be made to obtain FVIII activity measurements when a 72-hour interval without FVIII use is achieved; the 72-hour wash-out period is only intended for <b>subjects who have achieved FVIII ≥ 5 IU/dL at 16 weeks after BMN 270 infusion and who have not resumed FVIII replacement therapy.</b> If FVIII levels are elevated or stable <b>over the course of several weeks, assessment of FVIII activity may be adjusted based on discussion between the Medical Monitor and the Investigator.</b> A D-dimer may be considered under circumstances in which FVIII activity levels are above the normal physiological range <b>and/or if there is a concern for a venous thromboembolism.</b> If a subject tests positive in the Bethesda assay (with Nijmegen modification) during Years 3-5, a fresh sample should be collected within 4 weeks of the initial visit that had a positive result.</p> <p><sup>dd</sup> <b><u>AAV5 Tab assay and FVIII antibody titer collection should be performed quarterly through the end of Year 2, and then at End of Year Visits during Years 3-5.</u></b></p> | 1, 5, 6, 7, 8, 12 |

| Section No./Title  | Revision   | Rationale |
|--|--|-----------|
|  | <p><sup>c</sup> <u>AAV5 TI Assay should be performed only at the end of the study (either the Year 5 End of Year Visit, or at the ETV for subjects who withdraw prior to the end of Year 5).</u></p> <p><sup>eg</sup> Blood samples will be collected to evaluate biochemical, molecular, cellular, and genetic/genomic aspects relevant to hemophilia A, coagulation, and/or AAV gene transfer, and to develop assays used for these evaluations. Subjects may choose to opt out of the exploratory genetic/genomic research being done to study or try to discover genes that are not yet known to be associated with hemophilia A. While exploratory samples will be collected at the time points indicated above, testing of these samples (including those for TGA assay and any other exploratory assessments) will be performed only as deemed necessary by the Sponsor.</p> <p><sup>ei</sup> <u>Additional liver ultrasounds may be performed at interim timepoints (ie, between the End of Year visits) at the discretion of the Investigator.</u></p> <p><sup>ek</sup> An optional liver biopsy may be performed at any time between Years 2-5 of the study. The optional biopsy may be triggered by a FVIII activity decline by &gt; 50% from steady-state, over 2 consecutive measurements, or by a sustained ALT rise &gt; ULN. If neither triggered is observed, the optional biopsy may be performed at the end of Year 5. Subjects should fast for at least 8 hours prior to liver ultrasound and optional liver biopsies. <u>More than one liver biopsy may be performed during this period, as clinically indicated.</u></p> |           |
| Table 9.1.6/Schedule of Events (Therapeutic Corticosteroids) (footnotes) | <p><sup>b</sup> Following initiation or completion of steroid regimen, if a recurrence of ALT values &gt; ULN or <math>\geq 1.5x</math> baseline value is reported, steroid management decisions will be based on discussions between the Investigator and Medical Monitor. <u>Modification of the steroid regimen may take into consideration timing of ALT elevation (after Week 52), as well as possible confounders for the ALT elevation, relationship between increases in ALT and FVIII activity, ALT/FVIII levels post steroid initiation, and adverse events related to steroid dosing. Guidance for tapering oral corticosteroid dosing can be found in Section 9.4.8.2.</u></p>   | 5         |
| 9.2/Discussion of Study Design, including Choice of Control Group        | <p><u>Approximately 130 subjects will be enrolled at the 6E13 vg/kg BMN 270 dose. Subjects will initially be followed for 52 weeks post-BMN 270 infusion, during which safety and efficacy assessments will be taken. After the final The 1-year analysis for the study will be performed after all subject have been followed for 52 weeks post-BMN 270 infusion. A separate 2-year analysis will also be performed per request from the FDA after all subjects have been followed for 104 weeks post-BMN 270 infusion. After the 1-year analysis and the 2-year analysis, safety and efficacy will then continue to be assessed long-term in all subjects for a total of approximately a total of 5 years. During enrollment, the DMC will review available safety and efficacy data on an ongoing basis and may decide to recommend dosing subjects at a different dose level (not to exceed 6E13 vg/kg) based on emerging data from 270-301 and their overall benefit:risk assessment.</u></p>   | 3, 9, 12  |
| 9.4.8/Prior and Concomitant Medications                                  | <p>The following medications are prohibited starting 30 days before Screening and through the end of the study, and the Sponsor must be notified if a subject receives any of these during the study:</p> <ul style="list-style-type: none"> <li>Any investigational therapy <u>other than BMN 270</u></li> </ul>  | 4, 12     |

| Section No./Title   | Revision  | Rationale |
|---|---|-----------|
|   | <p>...</p> <p><u>Administration of SARS-CoV-2 vaccine after BMN 270 infusion may occur after consultation between Investigator and Medical Monitor. Investigators should use clinical judgment, taking into consideration local factors, individual risk factors, and the benefit/risk related to timing of vaccine administration.</u></p>   |           |
| 9.4.8.1/Concomitant Hemophilia Treatments                                   | Subjects on prophylactic FVIII therapy will discontinue their regular <b>treatment regimen starting 4 weeks after the day</b> of infusion and switch to an <b>“on-demand/episodic”</b> schedule.  | 12        |
| 9.4.8.2/Reactive Steroids for Elevated LTs                                  | <p><del>Therapeutic</del> <b>Reactive oral corticosteroids (prednisone or converted equivalent) should be initiated when either of the following occurs post-BMN 270 infusion in any subject and after consultation with the Medical Monitor (or their designee):</b></p> <ul style="list-style-type: none"> <li>• <b>ALT &gt; ULN or <math>\geq 1.5x</math> baseline value in 2 consecutive assessments within 72 hours and alternative etiologies have been ruled out, or ALT <math>\geq 3x</math> ULN in 2 consecutive assessments within 48 hours (refer to Table <del>9.7.8.3.2.1</del> <u>9.4.8.2.1</u>)</b> <ul style="list-style-type: none"> <li>○ Whenever possible, a confirmatory lab draw for ALT should be performed, along with FVIII activity, prior to initiating <u>reactive</u> oral corticosteroids.</li> <li>○ Corticosteroids may be delayed if elevations in ALT are clearly not related to BMN 270 (eg, elevated ALT with concurrent increase in CPK due to intensive exercise), <u>although this should be discussed with the Medical Monitor (in particular for elevations occurring more than 52 weeks after BMN 270 dosing).</u></li> </ul> </li> </ul> <p><u>Unless otherwise indicated, reactive corticosteroid treatment should be initiated at a dose of 60 mg/day. If the ALT level remains stable or declines after 2 weeks, consider gradual taper of corticosteroids: 40 mg/day for 3 weeks, 30 mg/day for 1 week, 20 mg/day for 1 week and 10 mg/day for 1 week. Should a scenario arise in which differences from the minimum recommended dose and/or duration of reactive corticosteroids may be clinically indicated, a discussion should take place between the Investigator and Medical Monitor regarding corticosteroid dose adjustments. Management of ALT elevations with reactive corticosteroids, including tapering of doses and managing worsening and/or recurrent ALT elevations, should be guided by the following (Table 9.4.8.2.1). The prescribed regimen for therapeutic oral corticosteroids is detailed in . Changes to the corticosteroid regimen should be made as follows (-):</u></p> | 5, 12     |
| Table 9.4.8.2.1/ Management of ALT Elevations with Reactive Corticosteroids | The former Table 9.7.8.3.2 was relocated to this section, and updated consistent with other changes in this amendment.  | 5, 12     |



| Section No./Title                                      | Revision   | Rationale |
|--|--|-----------|
| 9.4.8.2/Reactive Steroids for Elevated LTs (cont.)     | When ruling out alternative viral or autoimmune hepatitis as part of the elevated ALT workup, the following tests <u>should be performed (Table 9.4.8.2.2)</u> :   | 12        |
| Table 9.4.8.2.2/Viral and Autoimmune Hepatitis Testing | The former Table 9.7.8.3.3 was relocated to this section.  | 12        |
| 9.4.8.2/Reactive Steroids for Elevated LTs (cont.)     | After discontinuation of <u>reactive oral corticosteroids</u> , labs for ALT and FVIII levels will be measured once a week for 4 weeks to ensure stability in values.<br>Following <del>initiation or completion of therapeutic</del> <u>reactive oral corticosteroids</u> , if ALT elevation (eg, > ULN or $\geq 1.5x$ baseline value) is reported, corticosteroid management decisions will be based on discussions between the Investigator and Medical Monitor. Modification of the corticosteroid regimen may take into consideration possible confounders for the ALT elevation and impact on FVIII expression.  | 12        |
| 9.4.8.3/Monitoring of HIV Positive Subjects            | HIV-positive subjects who have previously enrolled in 270-301 should continue anti-retroviral therapy (ART) as prescribed and follow routine monitoring of CD4 count and viral load (US Dept Health Human Services, <u>2014 2019</u> ).  | 12        |
| 9.7.2.1/FVIII Activity                                 | <p>In the event of an FVIII activity level decline during the study:</p> <ul style="list-style-type: none"> <li>● <del>If FVIII activity has declined at least 20% from the peak but less than 35% and has declined for at least 2 consecutive assessments, FVIII activity and LTs should be repeated every 7 days until FVIII activity is stable or increasing</del></li> <li>● <del>If FVIII activity has declined &gt;35% from the peak and has declined for at least 2 consecutive assessments, FVIII activity and LTs should be repeated every 72 hours until FVIII activity is stable or increasing</del></li> </ul> <p>Note that fluctuations in FVIII activity after gene therapy are common, and if <del>no clear trend indicating a decline in</del> <u>more frequent monitoring of FVIII activity levels is observed, then this additional testing may be deferred (not needed in the absence of a concurrent or recent ALT elevation or upon consultation between the Investigator and the Medical Monitor) until either a more clear trend of decline has been demonstrated or until the FVIII activity levels stabilize or increase.</u></p> <p>Subjects who do not respond to BMN 270 treatment (ie treatment failure, manifesting as <del>either failure to achieve FVIII activity <math>\geq 5</math> IU/dL by Week 52 or and inability to maintain independence from prophylactic FVIII replacement therapy due to joint bleeding episodes, in the judgment of the Investigator</del>) may, at the Investigator's discretion and after discussion with the Medical Monitor or Sponsor-designated Data Monitor, follow an abbreviated visit schedule after Week 52 of the study by attending only the Q12W and End of Year visits during Years 2-5.</p> | 7, 12     |

| Section No./Title   | Revision   | Rationale |
|---|--|-----------|
| <b>9.7.3.1/FVIII Replacement Therapy/ Bleeding Episodes</b> | <p>Secondary efficacy variables are:</p> <ul style="list-style-type: none"> <li>• <b>Change of the annualized utilization (IU/kg) of exogenous FVIII replacement therapy <u>during in the efficacy evaluation period (“Week 5 to <del>Week 52 post BMN 270 infusion</del>Last Visit”)</u></b> from the baseline utilization of exogenous FVIII replacement therapy.</li> <li>• <b>Change in the annualized number of bleeding episodes requiring exogenous FVIII replacement treatment <u>during in the efficacy evaluation period (“Week 5 to <del>Week 52 of the study post BMN 270 infusion</del>Last Visit”)</u></b> from the baseline ABR.</li> </ul> <p><b>Subjects must have high quality</b> documented historical data available concerning previous bleeding episodes and <b>exogenous FVIII usage over the previous 12 months</b> in order to be eligible to enroll in the study. During the study, <b>subjects will be asked at each study visit to report the</b> use of factor replacement therapy and the number of bleeding episodes since the previous visit. This information will be captured on the subject’s diary or other subject records. <u>Subjects will be encouraged to discuss any bleeding episodes with the Investigator and attempt to objectively assess any reported bleeds through use of ultrasound or non-invasive imaging.</u></p> | 3, 12     |
| <b>9.7.7.1/Optional Liver Biopsy</b>                        | <p><b>Additional liver biopsies at times deemed to be clinically relevant (eg, decreasing FVIII at a time of increased ALT) may be pursued, at any time during Years 2-5.</b> Subjects will be asked to consent to the procedure for each liver biopsy performed during the study.</p>   | 10        |
| <b>9.7.8.3/Malignancies</b>                                 | <p><u>Liver ultrasounds will be performed annually at each End of Year visit <b>starting at Year 2 (Week 104) through the end of the study</b> to screen for HCC. Additional liver ultrasounds may be performed between the End of Year visits at the discretion of the Investigator.</u></p> <p><u><b>Any development of a malignancy (except non-melanoma skin cancers) during the course of the study will be considered an EOSI (refer to Section 10.2.1) and is subject to expedited reporting. In addition, it is recommended that genomic analyses be performed on any malignancy (except non-melanoma skin cancers) diagnosed during the course of the study. The study site will coordinate sending samples from the malignancy for genomic analyses, if available.</b></u></p>   | 1, 2      |
| <b>9.7.8.4/Liver and Hepatitis Testing</b>                  | <p><b>Elevated ALT levels (above the upper limit of normal range) should be evaluated according to the following plan outlined in Table 9.4.8.2.1 (note that these evaluations may indicate additional testing of LTs and FVIII levels at unscheduled visits; these unscheduled laboratory tests may be completed by a mobile nursing professional at sites where the use of MN services has been approved).</b></p> <p><i>Table 9.7.8.3.2 and Table 9.7.8.3.3 were relocated to Section 9.4.8.2 (as mentioned above).</i></p>   | 12        |
| <b>9.7.8.6/Vital Signs, Physical Exam, and Other Safety</b> | <p>A complete physical examination will include <b>general appearance (head, eyes, ears, nose, and throat), cardiovascular, dermatologic, lymphatic, respiratory, gastrointestinal, genitourinary, musculoskeletal, and neurologic systems.</b> <u>The <b>genitourinary examination may be deferred for visits after Year 1 unless the subject has genitourinary-related complaints.</b></u></p>   | 12        |

| Section No./Title                      | Revision   | Rationale |
|--|--|-----------|
| 10.2.1/EOSI                            | The following EOSI need to be reported to the Sponsor within 24 hours of site awareness, irrespective of seriousness, severity or causality: <ul style="list-style-type: none"> <li>Any new diagnosis of malignancy (except non-melanoma skin cancer)</li> </ul>   | 2         |
| 10.8/Urgent Safety Measures            | Investigators are required to report any events which may require the implementation of urgent safety measures to BioMarin within 24 hours of becoming aware of the event.   | 12        |
| 10.9/Contact Information               | Contact information for the Medical Monitor is as follows:<br>Name: PI [REDACTED] MD, MSc, MBA PhD<br>Address: PI [REDACTED]<br>Phone: PI [REDACTED]<br>E-mail: [REDACTED]   | 11        |
| 12.7/Post-Infusion Follow-Up Years 2-5 | Subjects who do not respond to BMN 270 treatment (ie, treatment failure, manifesting as either failure to achieve FVIII activity $\geq 5$ IU/dL by Week 52 <del>or</del> and inability to maintain independence from prophylactic FVIII replacement therapy due to joint bleeding episodes, in the judgment of the Investigator) may, at the Investigator's discretion and after discussion with the Medical Monitor or Sponsor-designated Data Monitor, follow an abbreviated visit schedule after Week 52 of the study by attending only the Q12W and End of Year visits during Years 2-5.   | 7         |
| 12.7.1/Year 2 – Every 4 Weeks          | During Year 2, every 4 weeks ( <del><math>\pm</math></del> $\pm 2$ weeks), the following procedures will be performed: <ul style="list-style-type: none"> <li>Liver Tests (refer to Table 9.7.8.3.1) <ul style="list-style-type: none"> <li><del>LTs</del>LT assessment may be <del>monitored</del>checked more or less frequently (and in particular when ALT values are <math>&gt; \text{ULN}</math> or <math>\geq 1.5x</math> baseline value) or based <del>on</del>upon discussion between the Medical Monitor and the Investigator and review of subject data, but LTs will be monitored at least twice weekly during periods when a subject's ALT is <math>\geq 3x \text{ULN}</math>.</li> </ul> </li> <li><del>—</del> FVIII protein assay</li> </ul> | 5, 8, 12  |
| 12.7.2/Years 3-5 – Every 6 Weeks       | During Years 3-5, every 6 weeks ( $\pm 2$ weeks), the following procedures will be performed: <ul style="list-style-type: none"> <li>Liver Tests (refer to Table 9.7.8.3.1) <ul style="list-style-type: none"> <li><del>LTs</del>LT assessment may be <del>monitored</del>checked more or less frequently (and in particular when ALT values are <math>&gt; \text{ULN}</math> or <math>\geq 1.5x</math> baseline value) or based <del>on</del>upon discussion between the Medical Monitor and the Investigator and review of subject data, but LTs will be monitored at least twice weekly during periods when a subject's ALT is <math>\geq 3x \text{ULN}</math>.</li> </ul> </li> <li><del>—</del> FVIII protein assay</li> </ul>                          | 5, 8, 12  |

| Section No./Title                                       | Revision   | Rationale      |
|---|--|----------------|
| 12.7.3/Years 2-5 –<br>Every 12 Weeks                    | <p>At the every 12 week and End of Year visits, the following procedures will be performed:</p> <ul style="list-style-type: none"> <li>• Physical examination <ul style="list-style-type: none"> <li>○ Complete physical examination will be performed at the End of Year visits; (<u>genitourinary examination may be deferred</u>); brief physical examination may be performed at other visits.</li> </ul> </li> <li>• <b>Liver Tests (refer to Table 9.7.8.3.1)</b> <ul style="list-style-type: none"> <li>○ <del>LTs</del><u>LT assessment</u> may be <del>monitored</del><u>checked</u> more or less frequently (<del>and in particular</del> when ALT values are &gt; ULN or <math>\geq 1.5x</math> baseline value) or based <del>on</del><u>upon</u> discussion between the Medical Monitor and the Investigator and review of subject data, <del>but LTs will be monitored at least twice weekly during periods when a subject's ALT is <math>\geq 3x</math> ULN.</del></li> </ul> </li> <li>• AAV5 TAb Assay (<u>at Week 64, Week 76, Week 88, Week 104, then at End of Year visit for Years 3-5</u>)</li> <li>• AAV5 TI Assay (<u>at End of Year 5 visit only</u>)</li> <li>• FVIII antibody titer (<u>at Week 64, Week 76, Week 88, Week 104, then at End of Year visit for Years 3-5</u>)</li> <li>• <del>TGA Assay</del></li> <li>• <b>Liver ultrasound (at End of Year visits only)</b> <ul style="list-style-type: none"> <li>○ <u>Additional liver ultrasounds may be performed at interim time points (ie, between the End of Year visits) at the discretion of the Investigator.</u></li> </ul> </li> </ul> | 1, 5, 6, 8, 12 |
| 12.8/Early Termination Visit                            | <p>At the Early Termination visit, as many of the following assessments as possible should be done:</p> <ul style="list-style-type: none"> <li>• <del>TGA Assay</del></li> <li>• <u>Liver ultrasound</u></li> </ul>  | 1, 6           |
| 14/Statistical Methods and Determination of Sample Size | <u>Additional statistical information for the 2-year analysis for the United States is provided in Appendix 2 (Section 25) of this protocol.</u>   | 9              |
| 14.1.1/Interim Analyses                                 | <p><b>The fallback procedure (Wiens, 2005) will be used to adjust for multiplicity of the two interim analyses at Week 26, the <del>final</del>1-year analysis at Week 52, and the 2-year analysis at Week 104 (regardless of the interim analyses results, the study is planned to continue upon the DMC's recommendation, <del>and the final analysis will be performed at Week 52</del>).</b> At the <del>final</del>1-year analysis at Week 52 and the 2-year analysis at Week 104, the secondary efficacy endpoints will be tested hierarchically; the level of significance will be determined by the fallback procedure.</p>  | 3, 9           |
| 14.3/Secondary Efficacy Endpoints                       | <p>For the first-<del>ranked</del> secondary efficacy endpoint <del>at Week 52 (ie, the change in the annualized utilization (IU/kg) of exogenous FVIII replacement therapy during Weeks in the efficacy evaluation period (“Week 5-52 post-BMN 270 infusion to Last Visit”)) from baseline</del>, a one-sample t-test will be performed to test the null hypothesis that the change</p>   | 3              |

| Section No./Title   | Revision   | Rationale |
|---|--|-----------|
|   | <p>is 0 or greater against the alternative hypothesis that the change is less than 0. The missing value of the change will be imputed as 0.</p> <p>For the second-<del>ranked</del> secondary efficacy endpoint at Week 52 (ie, the change in ABR, <del>annualized bleeding rate, during Weeks in the efficacy evaluation period (“Week 5-52 post-BMN 270 infusion to Last Visit”)</del> from baseline), a one-sample t-test will be performed to test for non-inferiority of BMN 270 against FVIII prophylaxis (ie, the baseline ABR calculated using subjects’ data collected as part of 270-902) using a non-inferiority margin of 3.5, ie, to test the null hypothesis that the change is 3.5 or greater against the alternative hypothesis that the change is less than 3.5.</p>  |           |
| 14.8/Determination of Sample Size                             | <p>For the secondary endpoints, the analysis will be performed utilizing exogenous FVIII use and bleeding episode data from the 110 subjects whose baseline data will be prospectively collected for approximately 6 months in the non-interventional study 270-902, prior to their enrollment in Study 270-301. An analytic sample size of 110 will provide at least 95% power to demonstrate that the change in the annualized utilization (IU/kg) of exogenous FVIII replacement therapy <del>during in the efficacy evaluation period (“Week 5 to Week 52 post-BMN 270 infusion Last Visit”)</del> from the baseline is less than 0, assuming an effect size of 0.6 conservatively, using one-sample t-test with a 2-sided significance level of 0.05.</p> <p>For the analytic sample size calculation of the second-<del>ranked</del> secondary endpoint, ABR, it is assumed that the pre- and post-BMN 270 infusion population mean ABRs are 3.5 and 1 respectively, and the distribution of ABRs is negative binomial distribution with a dispersion parameter of 2.2. Given the underlying negative binomial distributions, the standard deviations of the pre- and post-BMN 270 infusion ABRs are calculated as 7.8 and 1.8 respectively. The mean (SD) of the change from the pre- to post-BMN 270 infusion ABRs are calculated as -2.5 (8) assuming the correlation between pre- and post-BMN 270 infusion ABRs is zero. Under this assumption, an analytic sample size of 110 will also have at least 95% power to demonstrate that the change in the annualized number of bleeding episodes requiring exogenous FVIII replacement treatment (ABR) <del>during in the efficacy evaluation period (“Week 5 to Week 52 of the study post-BMN 270 infusion Last Visit”)</del> from the baseline ABR is less than 3.5 (non-inferiority margin), using a one-sample t-test with a 2-sided significance level of 0.05. Under the same assumptions, a sample size of 110 will have approximately 90% power to demonstrate that the change is less than 0, ie, superiority of BMN 270 against FVIII prophylaxis.</p> <p>Overall, the planned sample size will have greater than 80% power for testing the primary and secondary efficacy endpoints hierarchically at the <del>final</del> 1-year analysis with a 2-sided significance level of 0.05.</p> | 3, 12     |
| 14.10/Changes in the Conduct of the Study or Planned Analyses | If discrepancies exist in statistical methods between the SAP and the study protocol, the SAP will prevail.  | 12        |
| 18/Study Monitoring and Auditing                              | Qualified individuals designated by BioMarin will monitor all aspects of the study according to GCP and standard operating procedures for compliance with applicable government regulations. The Investigator agrees to allow these monitors direct access to the clinical supplies, dispensing, and storage areas and to the clinical files, including original   | 12        |



| Section No./Title    | Revision   | Rationale |
|----------------------|--|-----------|
|                      | <p>medical records, of the study subjects, and, if requested, agrees to assist the monitors. The Investigator and staff are responsible for being present or available for consultation during routinely scheduled site visits conducted by BioMarin or its designees. <u>When in person site monitoring or source data verification cannot be conducted, remote site monitoring and/or source data verification will be conducted where allowed by country and local health authorities and ECs/IRBs.</u></p>   |           |
| 21/References        | <p>Haemo-QoL Study Group. Scoring Manual. Available at: <a href="http://haemoqol.de/scoring/manual">http://haemoqol.de/scoring/ manual</a>. Last accessed <del>28 July 2017</del> <u>17 May 2021</u>.</p> <p><u>Iorio A, Stonebraker JS, Chambost H, et al, for the Data and Demographics Committee of the World Federation of Hemophilia. Establishing the Prevalence and Prevalence at Birth of Hemophilia in Males: A Meta-analytic Approach Using National Registries. Ann Intern Med. 2019;171(8):540-546.</u></p> <p><del>Nathwani AC, Tuddenham EG. Epidemiology of coagulation disorders. Baillieres Clin Haematol 5[2], 383-439. 1992.</del></p> <p><del>Pasi KJ, Rangarajan S, Kim B, Mitchell N, Lester W et al. Achievement of Normal Circulating Factor VIII Activity Following BMN 270-Multiyear Follow-up of AAV5-FVIIIhFVIII-SQ Gene Transfer: Interim, Long-Term Efficacy and Safety Results from a Phase 1/2 Study in Patients with Severe Therapy for Hemophilia A. Blood 130[Suppl. 1], 603. 2017 N Engl J Med. 2020;382(1):29-40.</del></p> <p><del>Reilly M. WPAI Scoring. 2002. Available at: <a href="http://www.reillyassociates.net/WPAI_Scoring.html">http://www.reillyassociates.net/ WPAI_Scoring.html</a>. Last accessed <del>28 July 2017</del> <u>17 May 2021</u>.</del></p> <p><del>Srivastava A, Brewer AK, Mauser-Bunschoten EP, Key NS, Santagostino E, Dougall A, Kitchen S et. al. WFH guidelines for the management of hemophilia-128-, 3rd edition. Haemophilia 19[. 2020;26(Suppl 6):1], e1-47. 2013-158.</del></p> <p><del>United States Department of Health and Human Services. Panel on Antiretroviral Guidelines for Adults and Adolescents. Guidelines for the Use of Antiretroviral Agents in HIV-1-Infected Adults and Adolescents, 2014, with HIV. 2019. Available at <del>https://</del> <a href="http://www.aidsinfo.nih.gov/guidelines/html/1/adult-and-adolescent-arv-guidelines/458/plasma-hiv-1-rna-viral-load-and-cd4-count-monitoring-ContentFiles/AdultandAdolescentGL.pdf">http://www.aidsinfo.nih.gov/guidelines/html/1/adult-and-adolescent-arv-guidelines/458/plasma-hiv-1-rna-viral-load-and-cd4-count-monitoring-ContentFiles/ AdultandAdolescentGL.pdf</a> (last accessed <del>28 July 2017</del> <u>17 May 2021</u>).</del></p> | 12        |
| 23/Signature Page    | Printed name: <del>Adebayo Lawal</del> Tara Robinson, MD, MSc, MBA, Senior PhD, Associate Medical Director, Clinical Sciences  | 11        |
| <u>25/Appendix 2</u> | Appendix 2 (Region-Specific Study Objectives, Endpoints, and Analyses ["2-Year Analysis"] for the United States) has been added as part of this protocol amendment.  | 9         |