

CATALOGUE



**SERIES C-TRUCK**  
FITTINGS FOR AIR BRAKE  
SYSTEMS



# C\_TRANSPORT

## SOLUTIONS FOR THE TRANSPORT SECTOR

C\_Transport is the department within Camozzi which is focused on the development and production of components and solutions for the transport sector.

For the team of C\_Transport the clear target of every project is to deliver a product that is the best fit for the needs and expectations of the global markets. In close cooperation with our customers and partners, we develop and deliver customized solutions which clearly differentiate through high performance, smart and effective designs and last but not least excellent quality.

Operation in harsh conditions such as extreme temperatures, dirty or corrosive environments, exposure to high mechanical loads or vibrational stress is demanding, and developing the right product is the mission that our experienced and motivated engineers are working for - EVERY DAY.

The range of Series C-Truck fittings has been developed for an easy installation and reliable operation. The compact and slim design of this robust brass air brake fitting line is the first choice for use on all kinds of commercial vehicles and trailers.

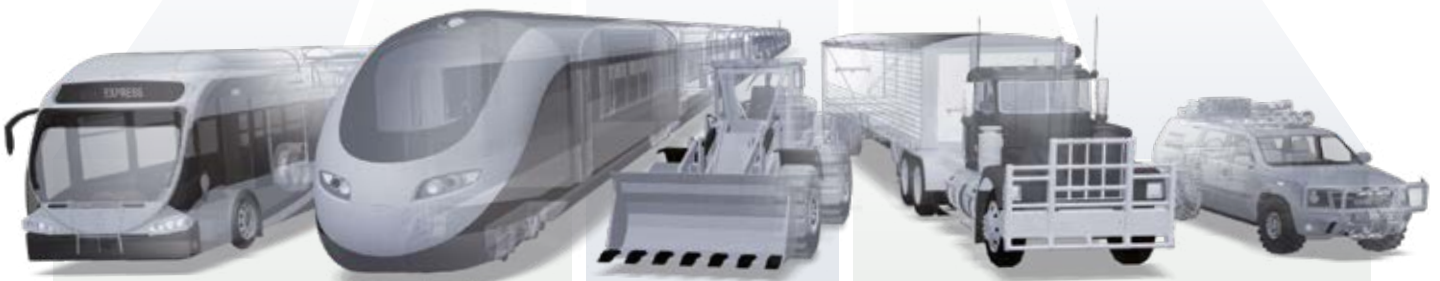

BUS & COACH



RAILWAY



OFF HIGHWAY



TRUCK & TRAILER



PASSENGER CAR

*Products  
Technology  
Solutions*

*Comfortable  
Reliable  
Safe*

*No matter where,  
when or what means  
of transport*

We take you further.

## Series C-Truck fittings

<b>Mod. 9512</b> Page 5	<b>Mod. D6512</b> Page 5	<b>Mod. 9510</b> Page 5	<b>Mod. 9463</b> Page 6	<b>Mod. 9502</b> Page 6	<b>Mod. 9500</b> Page 7
<b>Mod. 9412</b> Page 7	<b>Mod. 9410</b> Page 7	<b>Mod. 9422</b> Page 8	<b>Mod. 9420</b> Page 8	<b>Mod. 9102</b> Page 8	<b>Mod. 9590</b> Page 9
<b>Mod. 9590 con cono 24°</b> Page 9	<b>Mod. 9592</b> Page 9	<b>Mod. 9580</b> Page 9	<b>Mod. 9540</b> Page 10	<b>Mod. 9555</b> Page 10	<b>Mod. 9450</b> Page 10
<b>Mod. 9402</b> Page 10	<b>Mod. D2512 and D2502</b> Page 11	<b>Mod. D2532</b> Page 11	<b>Mod. D2612</b> Page 11	<b>Mod. D2602</b> Page 11	<b>Mod. D2022</b> Page 12
<b>Mod. D2062</b> Page 12	<b>Mod. D2072</b> Page 12	<b>Mod. D2003</b> Page 12	<b>Mod. D2003-S01</b> Page 13	<b>Mod. D2032</b> Page 13	<b>Mod. D2077</b> Page 13
<b>Mod. D3043</b> Page 13	<b>Mod. VPC2</b> Page 14	<b>Mod. VDC2</b> Page 14	<b>Mod. V604</b> Page 14		

## Accessories

<b>Mod. TRN</b> Page 15	<b>Mod. DRK</b> Page 15	<b>Mod. PNZ and PNPZ</b> Page 15
		

## Repair kits

<b>TRUCK-DCASE/9000</b> Page 16	<b>TRUCK-DCASE/6000</b> Page 16	<b>TRUCK-DCASE/9000+6000</b> Page 16
		

# Series C-Truck Fittings for air brake systems

## Tube dimensions

4x1; 6x1; 8x1; 10x1; 10x1,5; 12x1,5; 15x1,5; 15x2; 16x1,5; 16x2; 18x2

## Thread dimension

Metric: M10x1; M12x1,5; M14x1,5; M16x1,5; M18x1,5; M22x1,5  
Conical: 1/8" NPTF and 3/8" NPTF

SERIES C-TRUCK



Series C-Truck fittings have been designed to connect the tubes in the pneumatic braking system of commercial vehicles and trailers. During development we focused on reliability and ease of assembly.

After a tube is connected to the fitting, the tube can again be removed by using a dedicated C-Truck release tool, thus the fitting can remain mounted in the threaded port of the air brake system.

Each fitting has a rubber cap, to protect against dirt and water.

Series C-Truck fittings are certified and produced acc. IATF 16949:2016 standards.

The robust brass body of the fittings ensures safe operation in harsh conditions and high resistance against corrosion.

The internal support tube guarantees a proper and stable positioning and fixation of the inserted air brake tube, even when exposed to temperature variations or dynamic vibrations.

O-rings and protective cap are produced from NBR rubber and thus are resistant to oil. Series C-Truck fittings are supplied pre-assembled and are therefore ready to use.

## General data

<b>Thread type</b>	Metric acc. ISO965 / Conical NPTF acc. ANSI B1.20.3	
<b>Media</b>	Compressed air (other fluids, please contact our technicians)	
<b>Operating pressure</b>	Up to 16 bar (review also tube specifications)	
<b>Operating temperature</b>	-50°C up to 100°C (review also tube specifications)	
<b>Tubes</b>	Designed for use with Hytrel® or polyamide tubing, compliant with standards DIN 73378, DIN 74324 or ISO 7628	
<b>Materials</b>	<b>COMPONENT</b>	<b>MATERIAL</b>
	1 = Body	Brass
	2 = Support tube	Composite or Brass (depending on tube size)
	3 = Tube O-Ring	NBR
	4 = Collet	Brass
	5 = Protection Cap	NBR
	6 = Thread O-Ring	NBR
	7 = Locking ring	Brass

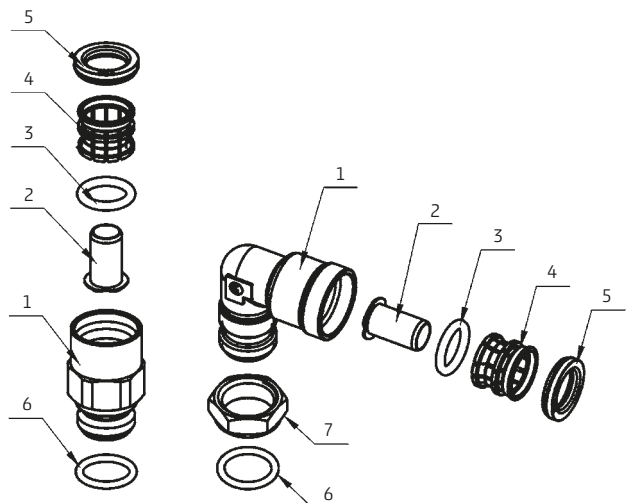

## Assembly and removal of the tube

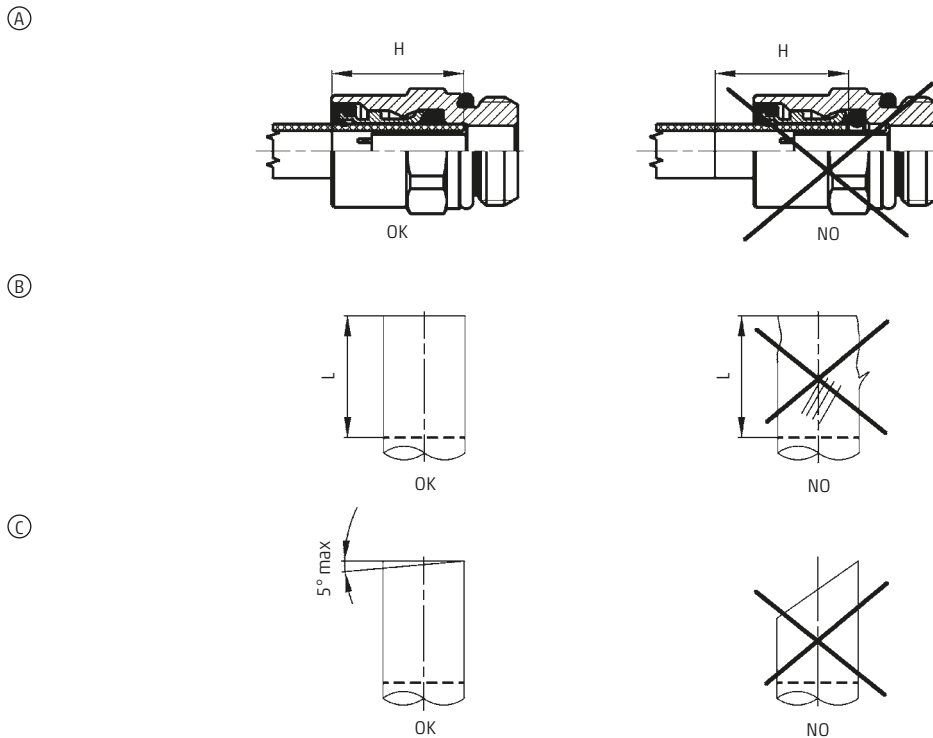

To achieve a correct, safe and tight connection, it is necessary that the end of the tube has been cut in the right way (picture C). The outer surface of the tube needs to be smooth and free from any kind of damage or dirt (picture B). To insert the tube properly, make sure to push it into the fitting up to the tube stop (picture A). The necessary insertion length is defined for every tube size/fitting in the table on the left side (Assembly length H). We recommend to suitably mark the tube, to be able to control the correct tube insertion (picture A). When cutting the tube, the angle should not exceed 5° (picture C), thus we recommend to use the tube cutting tool mod. PNZ in this catalogue.

Tube	Outer diameter (mm)	Inner diameter (mm)	Assembly length H (mm)	Insert length L (mm)
4x1	4	2	18,5	9,5
6x1	6	4	17,5	9,5
8x1	8	6	19,5	9,5
10x1	10	8	21	11
10x1,5	10	7	21	11
12x1,5	12	9	21,5	11
15x1,5	15	11	25	11,5
15x2	15	12	25	11,5
16x1,5	16	13	27,5	13
16x2	16	12	27,5	13
18x2	18	14	27,5	13

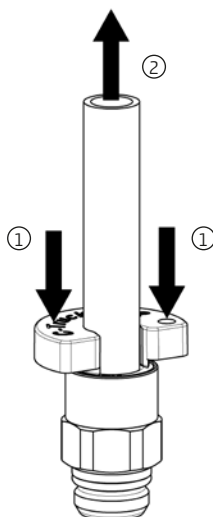

To remove the tube from the fitting, use the correct C-Truck release tool DRK from this catalogue, hook it on the tube and press down the protective cap. Whilst you press on top of the protective cap, the tube is released and you can pull it out of the fitting.

**Attention:** Do not remove a tube from a fitting when the system is still pressurized. Make sure you have released the complete air pressure before you remove a tube.

Tube assembly and disassembly must be carried out by a technician who is trained and has detailed knowledge of the airbrake system and the C-Truck fittings.

## Assembly of the fittings in the system

To ensure a tight and correct connection between the fitting and the threaded port of the component in the pneumatic system, please install according the following description:

1. Screw the nut upwards till you reach the mechanical stop (Comment: Please do not screw the nut against the stop with high torque forces applied by a tool. Please position the nut by hand, as shown in the pictures).

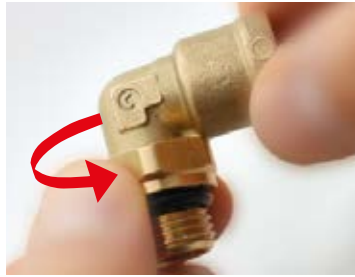

A

B

2. Screw the fitting into the threaded port until the O-ring seal touches the surface of the port. This can be done by hand or by a tool (Comment: We recommend to do this by hand (Picture A), to have a good haptic feedback once the right position is reached).



A

B

3. Bring the fitting into the final, desired position rotating it by max. 180° clockwise or anti-clockwise



4. Fix the position you have defined for your fitting with one hand and tighten the connection by screwing the nut downwards till you have reached the recommended torque (see table below).



5. The assembly is completed.



Thread	Torque force (Nm)
M10X1	11 - 15
M12X1.5	15 - 19
M14X1.5	19 - 23
M16X1.5	24 - 30
M18X1.5	27 - 33
M22X1.5	36 - 44

## Straight fittings Mod. 9512

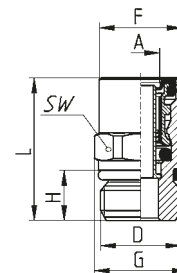

CHARACTERISTICS									
Mod.	A	D	F	G	H	L	SW	Weight (g)	Pack. (pcs)
9512 6-M10X1	6x1	M10X1	13,8	15	7	27,5	14	17,5	10
9512 6-M12X1,5R	6x1	M12X1,5	13,8	15	10	27,5	14	17,5	10
9512 6-M14X1,5R	6x1	M14X1,5	13,8	15	10	26,5	14	19,5	10
9512 6-M16X1,5R	6x1	M16X1,5	13,8	17	10	19,5	14	17,5	10
9512 8-M10X1	8x1	M10X1	16,5	18,5	7	30	17	26,5	10
9512 8-M12X1,5R	8x1	M12X1,5	16,5	18,5	10	32	17	28,5	10
9512 8-M14X1,5R	8x1	M14X1,5	16,5	18,5	10	29	17	26	10
9512 8-M16X1,5R	8x1	M16X1,5	16,5	18,5	10	28,5	17	29,5	10
9512 8-M22X1,5R	8x1	M22X1,5	16,5	23	10	21	19	39,5	10
9512 10/7-M12X1,5R	10x1,5	M12X1,5	17,8	19,5	10	33,5	18	26,5	10
9512 10/7-M16X1,5R	10x1,5	M16X1,5	17,8	19,5	10	29,5	18	29	10
9512 10/7-M22X1,5R	10x1,5	M22X1,5	18,5	23	10	22,5	19	37	10
9512 10-M12X1,5R	10x1	M12X1,5	17,8	19,5	10	33,5	18	26,5	10
9512 10-M16X1,5R	10x1	M16X1,5	17,8	19,5	10	29,5	18	29	10
9512 10-M18X1,5R*	10x1	M18X1,5	17,8	19,5	10	29,5	18	34	10
9512 10-M22X1,5R	10x1	M22X1,5	18,5	23	10	22,5	19	37	10
9512 12-M12X1,5R	12x1,5	M12X1,5	19,8	21,5	10	35,5	20	34	10
9512 12-M14X1,5R	12x1,5	M14X1,5	19,8	21,5	10	35	20	35,5	10
9512 12-M16X1,5R	12x1,5	M16X1,5	19,8	21,5	10	34	20	37	10
9512 12-M22X1,5R	12x1,5	M22X1,5	20,5	24	10	23	22	37	10
9512 15/11-M16X1,5R*	15x2	M16X1,5	23,8	26,5	10	39	24	53,5	10
9512 15/11-M22X1,5R*	15x2	M22X1,5	23,8	26,5	10	32	24	50,5	10
9512 15-M16X1,5R	15x1,5	M16X1,5	23,8	26,5	10	39	24	53,5	10
9512 15-M22X1,5R	15x1,5	M22X1,5	23,8	26,5	10	32	24	50,5	10
9512 16/12-M16X1,5R	16x2	M16X1,5	25	30	10	42,5	27	75	10
9512 16/12-M22X1,5R*	16x2	M22X1,5	25	30	10	35	27	68,5	10
9512 16-M22X1,5R	16x1,5	M22X1,5	25	30	10	35	27	68,5	10
9512 18-M22X1,5R	18x2	M22X1,5	26,8	30	10	40	27	68	10

\* on request only. The previous version is available while stocks last.

## Straight fittings Mod. D6512



Supplied without any insert

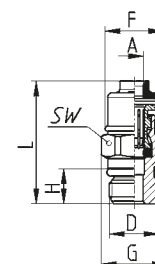

CHARACTERISTICS									
Mod.	A	D	F	G	H	L	SW	Weight (g)	Pack. (pcs)
D6512 4-M10X1	4x1	M10X1	11,7	13,2	7	24,5	12	9	10

## Straight fittings Mod. 9510

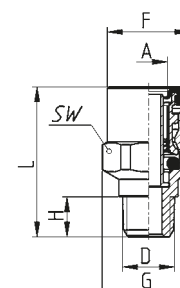

CHARACTERISTICS									
Mod.	A	D	F	G	H	L	SW	Weight (g)	Pack. (pcs)
9510 6-02	6x1	1/8 NPTF	13,8	15	8	24,5	14	16	10
9510 05-02	8x1	1/8 NPTF	16,5	18,5	8	30	17	27	10

## Fittings with female thread Mod. 9463

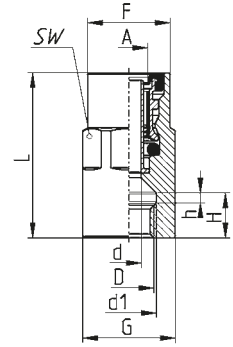

### CHARACTERISTICS

Mod.	A	D	d	d1	F	G	H	h	L	SW	Weight (g)	Pack. (pcs)
9463 6-M10X1	6x1	M10X1	5	11	13,8	15	9	2	31,5	14	27	10
9463 6-M12X1,5	6x1	M12X1,5	-	-	13,8	17	11	-	34	15	34	10
9463 6-M16X1,5	6x1	M16X1,5	-	-	15,3	21	10,5	-	34	19	51	10
9463 8-M10X1*	8x1	M10X1	5	11	16,5	18,5	9	2	35	17	46	10

\* on request only. The previous version is available while stocks last.

## Elbow fittings Mod. 9502

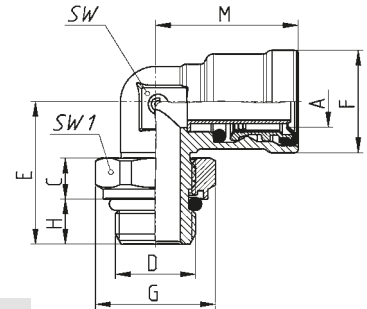

### CHARACTERISTICS

Mod.	A	C	D	E	F	G	H	M	SW	SW1	Weight (g)	Pack. (pcs)
9502 6-M10X1R	6x1	6	M10X1	22	14,5	16	7*	22,5	9	14	25	10
9502 6-M12X1,5R	6x1	8,2	M12X1,5	25	14,5	19	9	22,5	9	17	34	10
9502 6-M16X1,5R	6x1	8,2	M16X1,5	26	14,5	24	9	23	11	22	46,5	10
9502 6-M22X1,5R	6x1	8,2	M22X1,5	29	14,5	30	9	23	11	27	60	10
9502 8-M10X1R	8x1	6	M10X1	23	16,5	16	7*	25	11	14	30,5	10
9502 8-M12X1,5R	8x1	8,2	M12X1,5	26	16,5	19	9	25	11	17	39,5	10
9502 8-M14X1,5R	8x1	8,2	M14X1,5	26	16,5	21	9	25	11	19	40	10
9502 8-M16X1,5R	8x1	8,2	M16X1,5	26	16,5	24	9	25	11	22	45,5	10
9502 8-M22X1,5R	8x1	8,2	M22X1,5	29	16,5	30	9	25	11	27	60	10
9502 10/7-M12X1,5R*	10x1,5	8,2	M12X1,5	27	18,5	19	9	27	13	17	48	10
9502 10/7-M16X1,5R	10x1,5	8,2	M16X1,5	27,5	18,5	24	9	27	13	22	55,5	10
9502 10/7-M22X1,5R	10x1,5	8,2	M22X1,5	29	18,5	30	9	27	13	27	69,3	10
9502 10-M12X1,5R	10x1	8,2	M12X1,5	27	18,5	19	9	27	13	17	47	10
9502 10-M16X1,5R	10x1	8,2	M16X1,5	27,5	18,5	24	9	27	13	22	54	10
9502 10-M22X1,5R	10x1	8,2	M22X1,5	29	18,5	30	9	27	13	27	68	10
9502 12-M12X1,5R	12x1,5	8,2	M12X1,5	28,5	20,5	19	9	28,5	15	17	55,5	10
9502 12-M16X1,5R	12x1,5	8,2	M16X1,5	28,5	20,5	24	9	28,5	15	22	59,5	10
9502 12-M22X1,5R	12x1,5	8,2	M22X1,5	30	20,5	30	9	28,5	15	27	72,5	10
9502 15/11-M16X1,5R*	15x2	8,2	M16X1,5	31,5	24,5	24	9	34	18	22	94	10
9502 15/11-M22X1,5R*	15x2	8,2	M22X1,5	34	24,5	30	9	34	18	27	106	10
9502 15-M16X1,5R	15x1,5	8,2	M16X1,5	31,5	24,5	24	9	34	18	22	91	10
9502 15-M22X1,5R	15x1,5	8,2	M22X1,5	34	24,5	30	9	34	18	27	103	10
9502 16/12-M16X1,5R*	16x2	8,2	M16X1,5	33	25	24	9	35,5	21	22	114	10
9502 16/12-M22X1,5R	16x2	8,2	M22X1,5	33	25	30	9	35,5	21	27	117,5	10
9502 16-M22X1,5R	16x1,5	8,2	M22X1,5	33	25	30	9	35,5	21	27	117,5	10
9502 18-M22X1,5R	18x2	8,2	M22X1,5	33	27,5	30	9	35,5	21	27	115	10

\* on request only. The previous version is available while stocks last.



## Elbow fittings Mod. 9500

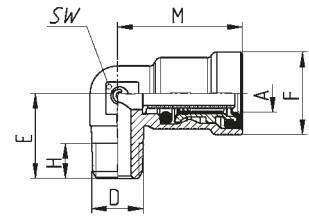

CHARACTERISTICS

Mod.	A	D	E	F	H (min)	M	SW	Weight (g)	Pack. (pcs)
9500 6-02	6x1	1/8 NPTF	17,5	14,5	8,5	21,5	9	18	10
9500 05-02*	8x1	1/8 NPTF	17	16,5	7	25	11	23	10
9500 12-06	12x1,5	3/8 NPTF	24,5	20,5	10,5	28,5	15	46	10

\* on request only. The previous version is available while stocks last.

## Tee fittings Mod. 9412

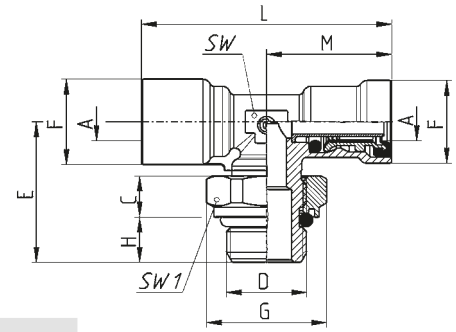

CHARACTERISTICS

Mod.	A	C	D	E	F	G	H	L	M	SW	SW1	Weight (g)	Pack. (pcs)
9412 6-M10X1R	6x1	6	M10X1	23	14,5	16	7	45	22,5	9	14	38	10
9412 6-M12X1,5R	6x1	8,2	M12X1,5	27,5	14,5	19	9	46	23	11	17	57	10
9412 6-M16X1,5R*	6x1	8,2	M16X1,5	28	14,5	24	9	46	23	11	22	64,5	10
9412 6-M22X1,5R	6x1	8,2	M22X1,5	32	14,5	30	9	49	24,5	15	27	87	10
9412 8-M12X1,5R	8x1	8,2	M12X1,5	27,5	16,5	19	9	50	25	11	17	59,5	10
9412 8-M16X1,5R	8x1	8,2	M16X1,5	28	17	24	9	50	25	11	22	67	10
9412 8-M22X1,5R	8x1	8,2	M22X1,5	32	16,5	30	9	53	26,5	15	27	95,5	10
9412 10/7-M12X1,5R*	10x1,5	8,2	M12X1,5	29	18,5	19	9	55	27,5	15	17	86	10
9412 10/7-M16X1,5R*	10x1,5	8,2	M16X1,5	29	18,5	24	9	55	27,5	15	22	91	10
9412 10/7-M22X1,5R*	10x1,5	8,2	M22X1,5	32	18,5	30	9	55	27,5	15	27	103	10
9412 10-M12X1,5R	10x1	8,2	M12X1,5	29	18,5	19	9	55	27,5	15	17	83	10
9412 10-M16X1,5R	10x1	8,2	M16X1,5	29	18,5	24	9	55	27,5	15	22	88	10
9412 10-M22X1,5R*	10x1	8,2	M22X1,5	32	18,5	30	9	55	27,5	15	27	100,5	10
9412 12-M12X1,5R*	12x1,5	8,2	M12X1,5	29	20,5	19	9	57	28,5	15	17	77	10
9412 12-M16X1,5R*	12x1,5	8,2	M16X1,5	29	20,5	24	9	57	28,5	15	22	83	10
9412 12-M22X1,5R	12x1,5	8,2	M22X1,5	32	20,5	30	9	57	28,5	15	27	95,5	10
9412 15/11-M16X1,5R*	15x2	8,2	M16X1,5	33,5	24,5	24	9	68	34	18	22	135,5	10
9412 15/11-M22X1,5R	15x2	8,2	M22X1,5	34	24,5	30	9	68	34	18	27	146,5	10
9412 15-M16X1,5R	15x1,5	8,2	M16X1,5	33,5	24,5	24	9	68	34	18	22	129,5	10
9412 15-M22X1,5R*	15x1,5	8,2	M22X1,5	34	24,5	30	9	68	34	18	27	140,5	10

\* on request only. The previous version is available while stocks last.

## Tee fittings Mod. 9410

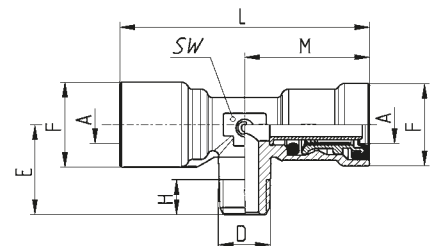

CHARACTERISTICS

Mod.	A	D	E	F	H	L	M	SW1	Weight (g)	Pack. (pcs)
9410 6-02	6x1	1/8 NPTF	17,5	14,5	7	45	22,5	9	30,5	10
9410 05-02*	8x1	1/8 NPTF	18	17	7	50	25	11	42	10

\* on request only. The previous version is available while stocks last.

## Tee fittings Mod. 9422

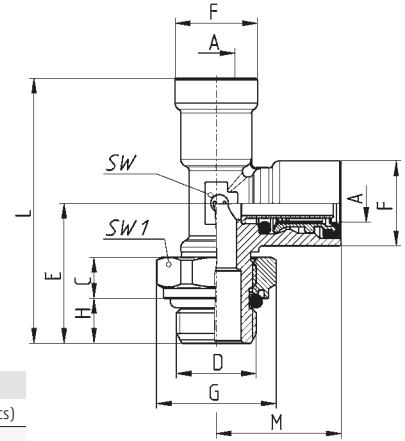

CHARACTERISTICS													
Mod.	A	C	D	E	F	G	H	L	M	SW	SW1	Weight (g)	Pack. (pcs)
9422 6-M10X1R	6x1	6	M10X1	23	14,5	16	7	45,5	22,5	9	14	37,5	10
9422 6-M12X1,5R	6x1	8,2	M12X1,5	27,5	14,5	19	9	50,5	23	11	17	57	10
9422 6-M16X1,5R*	6x1	8,2	M16X1,5	28	14,5	24	9	51	23	11	22	63,5	10
9422 8-M12X1,5R*	8x1	8,2	M12X1,5	27,5	17	19	9	52,5	25	11	17	59,5	10
9422 8-M16X1,5R	8x1	8,2	M16X1,5	28	17	24	9	53	25	11	22	67	10
9422 8-M22X1,5R	8x1	8,2	M22X1,5	32	16,5	30	9	58,5	26,5	15	27	95	10
9422 10-M16X1,5R	10x1	8,2	M16X1,5	29	18,5	24	9	56,5	27,5	15	22	88	10
9422 10-M22X1,5R	10x1	8,2	M22X1,5	32	18,5	30	9	59,5	27,5	15	27	100	10
9422 12-M12X1,5R*	12x1,5	8,2	M12X1,5	29	20,5	19	9	57,5	28,5	15	17	78	10
9422 12-M16X1,5R	12x1,5	8,2	M16X1,5	29	20,5	24	9	57,5	28,5	15	22	83	10
9422 12-M22X1,5R	12x1,5	8,2	M22X1,5	32	20,5	30	9	60,5	28,5	15	27	99,5	10
9422 15-M16X1,5R*	15x1,5	8,2	M16X1,5	33,5	24,5	24	9	67,5	34	18	22	130	10
9422 15-M22X1,5R*	15x1,5	8,2	M22X1,5	34	24,5	30	9	68	34	18	27	140,5	10

\* on request only. The previous version is available while stocks last.

## Tee fittings Mod. 9420

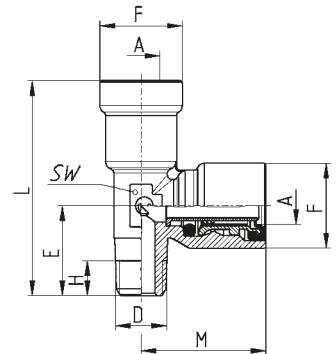

CHARACTERISTICS											
Mod.	A	D	E	F	H	L	M	SW	Weight (g)	Pack. (pcs)	
9420 6-02	6x1	1/8 NPTF	17,5	14,5	7	40	22,5	9	30	10	
9420 05-02*	8x1	1/8 NPTF	18	17	7	43	25	11	42	10	

\* on request only. The previous version is available while stocks last.

## 135° fittings Mod. 9102

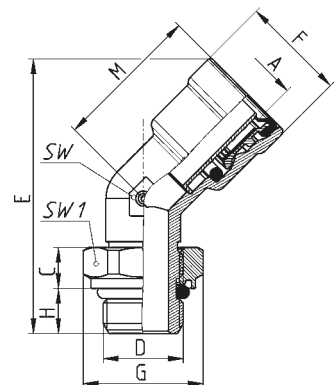

CHARACTERISTICS												
Mod.	A	C	D	E	F	G	H	M	SW	SW1	Weight (g)	Pack. (pcs)
9102 12-M16X1,5R**	12x1,5	8,2	M16X1,5	54,9	21,3	24	9	29,5	15	22	64	10

\*\* on request only.

## Bulkhead connectors Mod. 9590

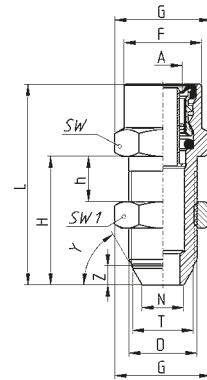

CHARACTERISTICS															
Mod.	A	D	F	G	H	h	L	N	T	Y	Z	SW	SW1	Weight (g)	Pack. (pcs)
9590 8-M18X1,5*	8x1	M18X1,5	-	25,5	50	10	55,5	10,8	15,7	53	4	22	22	99,5	10
9590 12-M18X1,5	12x1,5	M18X1,5	20,5	25,5	34	4	53	11	16	60	5	22	22	83	10
9590 12-M18X1,5-S04	12x1,5	M18X1,5	20,5	25,5	33	4	52	10,8	15,7	53	4	22	-	71	10

\* on request only. The previous version is available while stocks last.

## Bulkhead connectors Mod. 9590 with 24° cone

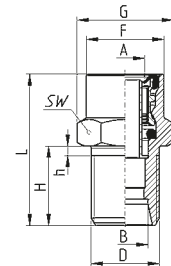

CHARACTERISTICS												
Mod.	A	B	D	F	G	H	h	L	SW	Weight (g)	Pack. (pcs)	
9590 6-M14x1,5	6x1	8	M14X1,5	14,5	20	21	2,5	36	17	36	10	
9590 8-M14x1,5	8x1	8	M14X1,5	16,5	20	21	2,5	43,5	17	46	10	
9590 8-M16x1,5	8x1	10	M16X1,5	16,5	22	21	2,5	37	19	44	10	
9590 12-M18x1,5-S06	12x1,5	12	M18X1,5	20,5	25,5	21	2,5	40	22	56	10	

## Bulkhead connectors Mod. 9592

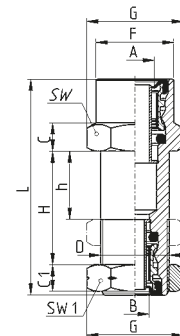

CHARACTERISTICS														
Mod.	A	B	C	C1	D	F	G	H	h	L	SW	SW1	Weight (g)	Pack. (pcs)
9592 8-8-M18X1*	8x1	8x1	5,5	7	M18X1	-	25,5	30	18	43,5	22	22	77	10
9592 12-8-M18X1*	12x1,5	8x1	7,5	7	M18X1	20,5	25,5	30	18	57	22	22	90,5	10

\* on request only. The previous version is available while stocks last.

## Connectors Mod. 9580

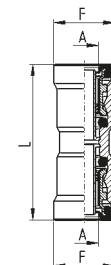

CHARACTERISTICS					
Mod.	A	F	L	Weight (g)	Pack. (pcs)
9580 6	6x1	14	37,5	21	10
9580 8	8x1	16	41	27	10
9580 10/7	10x1,5	18	44	34	10
9580 10	10x1	18	44	35	10
9580 12	12x1,5	20	45,5	43	10
9580 15/11	15x2	24	52	87	10
9580 16/12	16x2	25	58	100	10
9580 18	18x2	27	57	109	10

## Tee fittings Mod. 9540

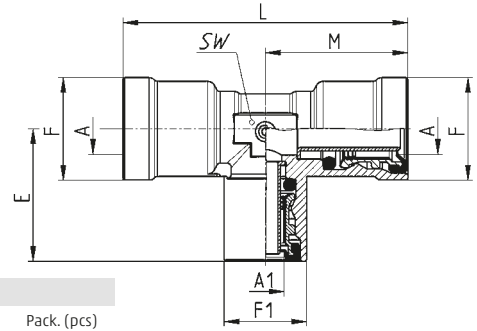

### CHARACTERISTICS

Mod.	A	A1	E	F	F1	L	M	SW	Weight (g)	Pack. (pcs)
9540 6	6x1	6x1	22,5	14,5	14,5	45	22,5	9	35,5	10
9540 8	8x1	8x1	25	17	17	50	25	11	53	10
9540 10/7*	10x1,5	10x1,5	27,5	18,5	18,5	55	27,5	15	84	10
9540 10	10x1	10x1	27,5	18,5	18,5	55	27,5	15	81	10
9540 12	12x1,5	12x1,5	28,5	20,5	20,5	57	28,5	15	73,5	10
9540 15/11*	15x2	15x2	34	24,5	24,5	68	34	18	137	10
9540 15	15x1,5	15x1,5	34	24,5	24,5	68	34	18	129	10
9540 8-8-6	8x1	6x1	23	17	14,5	50	25	11	50	10
9540 12-12-8	12x1,5	8x1	26,5	20,5	16,5	57	28,5	15	72	10

\* on request only. The previous version is available while stocks last.

## Fittings Mod. 9555

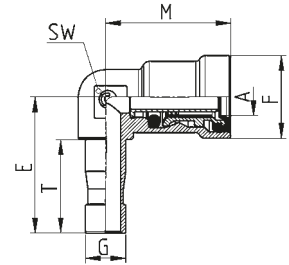

### CHARACTERISTICS

Mod.	A	G	T	E	F	M	SW	Weight (g)	Pack. (pcs)
9555 6-6**	6x1	6	16,9	25	14,5	22,5	9	17	10
9555 8-8**	8x1	8	18,7	27,2	16,5	25	11	23	10
9555 12-12**	12x1,5	12	20,7	32,2	21	29,5	15	45	10

\*\* on request only.

## Y fittings Mod. 9450

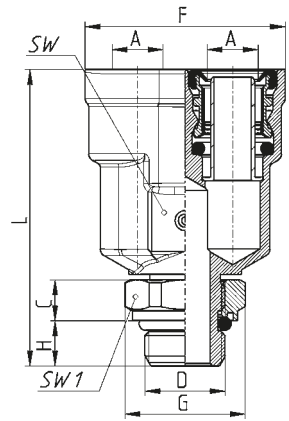

### CHARACTERISTICS

Mod.	A	C	D	F	G	H	L	SW	SW1	Weight (g)	Pack. (pcs)
9450 8-M16X1,5R	8x1	8,2	M16X1,5	31,5	24	9	49,3	14	22	71,5	10
9450 12-M16X1,5R*	12x1,5	8,2	M16X1,5	40	24	9	59,2	20	22	130,5	10
9450 12-M22X1,5R	12x1,5	8,2	M22X1,5	40	30	9	59,2	20	27	133	10

\* on request only. The previous version is available while stocks last.

## Elbow fittings Mod. 9402

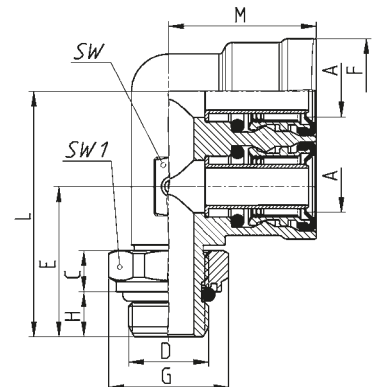

### CHARACTERISTICS

Mod.	A	C	D	E	F	G	H	L	M	SW	SW1	Weight (g)	Pack. (pcs)
9402 12-M16X1,5R*	12x1,5	8,2	M16X1,5	30	21	24	9	49	29,5	15	22	108	10
9402 12-M22X1,5R	12x1,5	8,2	M22X1,5	30	21	30	9	49	29,5	15	27	114,5	10

\* on request only. The previous version is available while stocks last.

## Bulkhead connectors Mod. D2512 and D2502

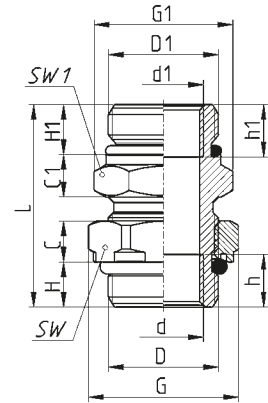

CHARACTERISTICS																	
Mod.	D	D1	d	d1	C	C1	G	G1	H	H1	h	h1	L	SW	SW1	Weight (g)	Pack. (pcs)
D2512 M22X1,5R-M16X1,5R	M22X1,5	M16X1,5	M16X1,5	M10X1	8,2	8,5	30	25,5	9	10	10,5	-	49,5	27	22	88	10
D2502 M22X1,5R-M22X1,5R-M16X1,5-L=39	M22X1,5	M22X1,5	M16X1,5	M16X1,5	8,2	8,5	30	28	9	10	10,5	10,5	40,5	27	24	79,5	10
D2502 M22X1,5R-M22X1,5R	M22X1,5	M22X1,5	-	-	8,2	8,5	30	28	9	10	-	-	40,5	27	24	84	10

## Reducer Mod. D2532

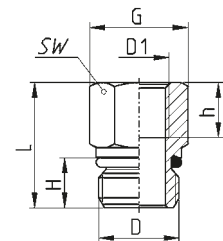

CHARACTERISTICS									
Mod.	D	D1	G	H	h	L	SW	Weight (g)	Pack. (pcs)
D2532 M16X1,5R-M12X1,5	M16X1,5	M12X1,5	20	10	11	25	17	25	10
D2532 M22X1,5R-M12X1,5	M22X1,5	M12X1,5	26,5	10	11	17,5	24	42,5	10
D2532 M22X1,5R-M16X1,5	M22X1,5	M16X1,5	26,5	10	10,5	17,5	24	31	10

## Taps Mod. D2612

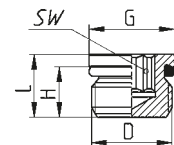

CHARACTERISTICS							
Mod.	D	H	L	G	SW	Weight (g)	Pack. (pcs)
D2612 M12X1,5R	M12X1,5	10	12	13	6	6,5	10
D2612 M16X1,5R	M16X1,5	10	12,5	17	8	13	10
D2612 M22X1,5R	M22X1,5	10	15	23	12	26	10

## Hose adapters Mod. D2602

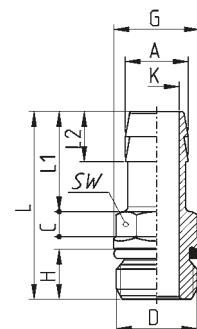

CHARACTERISTICS												
Mod.	A	D	C	G	H	L	L1	L2	K	SW	Weight (g)	Pack. (pcs)
D2602 10-M16X1,5R-L=30	11	M16X1,5	5	17	10	47,5	30	10	7,5	14	26,5	10
D2602 11,5-M16X1,5R-L=35	12,5	M16X1,5	5	17	10	52,5	35	10	9	14	27	10
D2602 12-M16X1,5R	12,5	M16X1,5	5	17	10	37,5	20	10	9	14	22	10
D2602 12-M22X1,5R	12,5	M22X1,5	5	23	10	38	20	10	9	14	35,5	10
D2602 13-M16X1,5-S01	15,5	M16X1,5	7	25,5	9	56	40	10	10	22	50	10

## Elbow fittings Mod. D2022

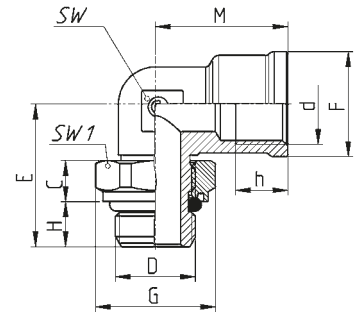

### CHARACTERISTICS

Mod.	d	D	C	E	F	G	H	h	M	SW	SW1	Weight (g)	Pack. (pcs)
D2022 M16X1,5-M16X1,5R	M16X1,5	M16X1,5	8,2	28,5	21	24	9	10,5	26,5	15	22	60,5	10
D2022 M16X1,5-M22X1,5R	M16X1,5	M22X1,5	8,2	30	21	30	9	10,5	26,5	15	27	71	10
D2022 M22X1,5-M22X1,5R	M22X1,5	M22X1,5	8,2	33	27	30	9	11	22	24	27	88	10

## Tee fittings Mod. D2062

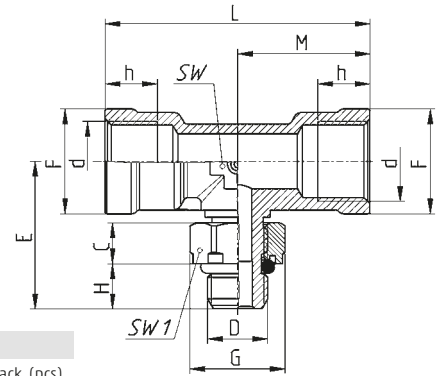

### CHARACTERISTICS

Mod.	d	D	C	E	F	G	H	h	L	M	SW	SW1	Weight (g)	Pack. (pcs)
D2062 M16X1,5-M12X1,5R	M16X1,5	M12X1,5	8,2	29,5	21	19	9	10,5	53	26,5	15	17	77	10
D2062 M16X1,5-M16X1,5R	M16X1,5	M16X1,5	8,2	30	21	24	9	12,5	37	18,5	20	22	70	10
D2062 M16X1,5-M22X1,5R	M16X1,5	M22X1,5	8,2	32	21	30	9	10,5	37	18,5	20	27	84,5	10
D2062 M22X1,5-M22X1,5R	M22X1,5	M22X1,5	8,2	33	27	30	9	11	64	32	20	27	131	10

## Tee fittings Mod. D2072

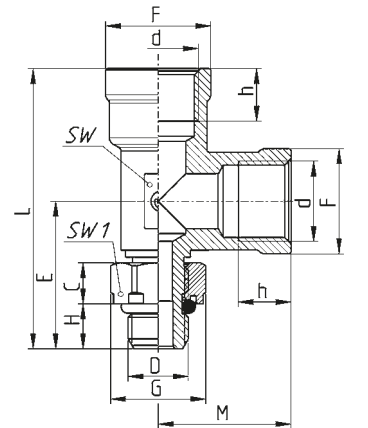

### CHARACTERISTICS

Mod.	d	D	C	E	F	G	H	h	L	M	SW	SW1	Weight (g)	Pack. (pcs)
D2072 M16X1,5-M12X1,5R*	M16X1,5	M12X1,5	8,2	29,5	21	19	9	10,5	56	26,5	15	17	75	10
D2072 M16X1,5-M16X1,5R	M16X1,5	M16X1,5	8,2	30	21	24	9	10	48,5	18,5	20	22	70	10
D2072 M16X1,5-M22X1,5R	M16X1,5	M22X1,5	8,2	32	21	30	9	10	50,5	18,5	20	27	82	10
D2072 M22X1,5-M22X1,5R	M22X1,5	M22X1,5	8,2	33	27	30	9	11	65	32	20	27	131	10

\* on request only. The previous version is available while stocks last.

## Tee fittings Mod. D2003

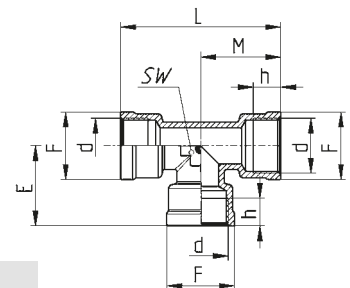

### CHARACTERISTICS

Mod.	d	E	G	h	M	L	N	O	P	R	SW	Weight (g)	Pack. (pcs)
D2003 M16X1,5	M16X1,5	18,5	21	10	18,5	37	-	-	-	-	20	53	10
D2003 M22X1,5	M22X1,5	32	27	11	32	64	-	-	-	-	20	126,5	10

**Tee fittings Mod. D2003...S01**

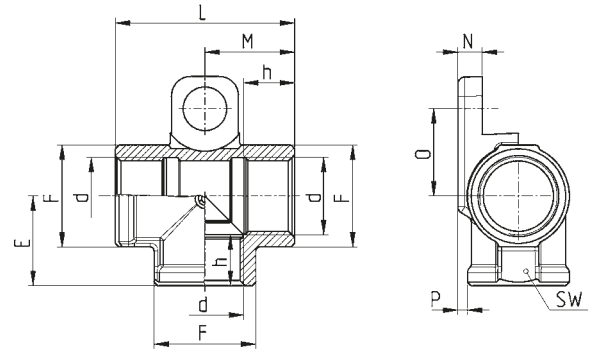

CHARACTERISTICS												
Mod.	d	E	G	h	M	L	N	O	P	R	SW	Weight (g) Pack. (pcs)
<b>D2003 M16X1,5-S01</b>	M16X1,5	18,5	21	10,5	18,5	37	5	18	2	9	21	68 10

**Cross fittings Mod. D2032**

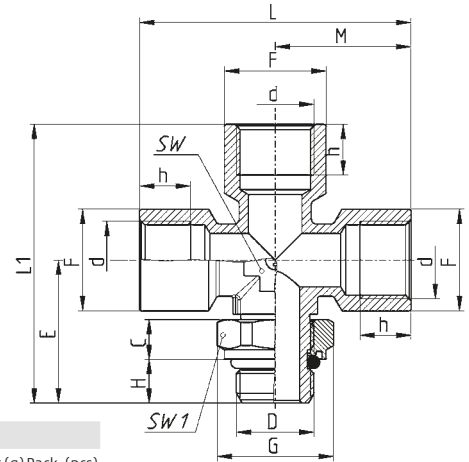

CHARACTERISTICS												
Mod.	d	D	C	E	F	G	H	h	L	L1	M	SW SW1 Weight (g) Pack. (pcs)
<b>D2032 M16X1,5-M16X1,5R</b>	M16X1,5	M16X1,5	8,2	29,5	21	24	9	10,5	56	57,5	28	16 22 110,5 10

**Elbow fittings Mod. D2077**

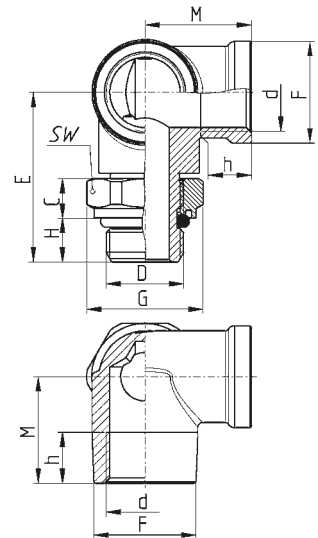

CHARACTERISTICS												
Mod.	D	d	C	E	F	G	H	h	M	SW	Weight (g) Pack. (pcs)	
<b>D2077 M16X1,5-M16X1,5R</b>	M16X1,5	M16X1,5	8,2	35	21	24	9	10,5	22	22	94,5 10	
<b>D2077 M16X1,5-M22X1,5R</b>	M22X1,5	M16X1,5	8,2	35,5	21	30	9	10,5	22	27	98 10	

**Fittings Mod. D3043**

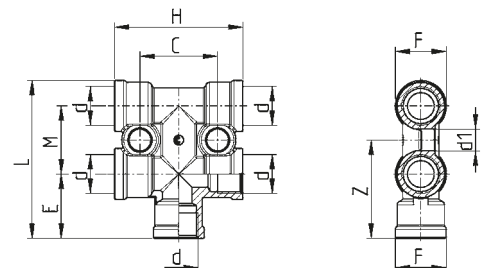

CHARACTERISTICS												
Mod.	d	d1	C	E	M	L	H	G	Z	Weight (g) Pack. (pcs)		
<b>D3043 M16X1,5-2D-M16X1,5-S01</b>	M16X1,5	9	32	26,5	28	65	53	21	40,5	147 10		

## Test point valve Mod. VPC2

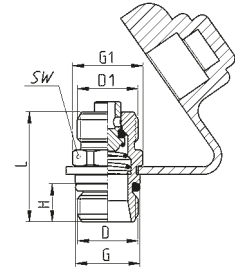

### CHARACTERISTICS

Mod.	D	D1	H	G	G1	L	SW	Weight (g)	Pack. (pcs)
VPC2 M16X1,5-M16X1,5R	M16X1,5	M16X1,5	10	17	18,5	29	17	33	10
VPC2 M22X1,5-M16X1,5R	M22X1,5	M16X1,5	10	23	18,5	29	17	41	10

## Drain valve Mod. VDC2

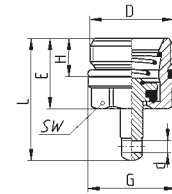

### CHARACTERISTICS

Mod.	D	d	E	G	H	L	SW	Weight (g)	Pack. (pcs)
VDC2 M22X1,5R	M22X1,5	3,2	18,5	23	10	32,1	19	29	10

## Tyre inflator valve Mod. V604



A = rod position for tyre inflation  
B = rod position for tank filling through air intake for tyre inflation

2 = energy supply  
3 = drain  
11, 12 = energy flow

Flow 2 ÷ 11 bar at 6 bar ΔP 1: 1620 l/min  
Flow 2 ÷ 12 bar at 6 bar with no interruption: 400 l/min  
Safety pressure: 10 bar Q = 100 l/min; 8 bar Q = 0 l/min

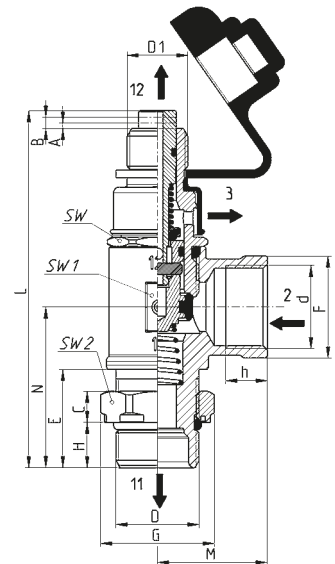

### CHARACTERISTICS

Mod.	C	D	D1	d	E	F	G	H	h	L	M	N	SW	SW1	SW2	Weight (g)	Pack. (pcs)
V604 M22X1,5R	8,2	M22X1,5	M16X1,5	M22X1,5	26	27	30	12	11	94,4	29	42,5	24	27	27	253	2



## Accessories

### ■ Tubes Mod. TRN



Black tubes in polyamide (PA12)

According to standards:

- DIN 74324 (except for Mod. TRN 16/13 NX)
- REACH REGULATION (EC N°1907/2006)
- EUROPEAN DIRECTIVE RoHS n° 2002/95/EC

CHARACTERISTICS						
Mod.	D/d	MAX pressure at 23°C (bar)	Weight (g/m)	Min. curve radius min. (mm)	Operating temperature (°C)	Size (m)
TRN 4/2 NX	4/2	49	9.6	16	-55°C ÷ +100°C	50
TRN 6/4 NX	6x1	29	16	30	-55°C ÷ +100°C	100
TRN 8/6 NX	8x1	21	22.4	40	-55°C ÷ +100°C	100
TRN 10/8 NX	10x1	16	28.8	60	-55°C ÷ +100°C	50
TRN 12/9 NX	12x1,5	21	50.4	60	-55°C ÷ +100°C	50
TRN 15/12 NX	15x1,5	16	64.9	90	-55°C ÷ +100°C	50
TRN 16/13 NX	16x1,5	13	71	120	-55°C ÷ +100°C	50
TRN 18/14 NX	18x2	18	102.5	100	-55°C ÷ +100°C	50

### ■ Tube cutter tool Mod. PNZ and PNZP



CHARACTERISTICS	
Mod.	
PNZ-12	able to cut tubes with Ø up to 12 mm
PNZ-25	able to cut tubes with Ø up to 25 mm
PNZP-12	able to cut tubes with Ø up to 12 mm

### ■ Tube disconnecting key Mod. DRK

Material: technopolymer



CHARACTERISTICS						
Mod.	A	G	H	L	Weight (g)	Pack. (pcs)
DRK 6	6	25	6	19	1	10
DRK 8	8	28.5	7	20	1	10
DRK 10	10	30.5	9	22	2	10
DRK 12	12	33	9	23	3	10
DRK 15	15	36	10	27	3	10
DRK 16	16	37	10	27.5	4	10
DRK 18	18	40	12	31	5	10

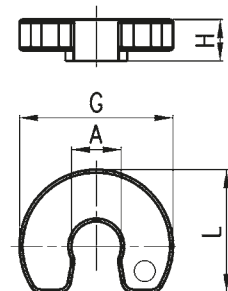

## REPAIR KITS

**For the pneumatic system  
of commercial vehicles and trailers.**

**Air brake & air suspension  
> Series C-Truck**

**Accessories  
> Series 6000**

The TRUCK-DCASE kits enable drivers to repair tube damages or other smaller issues on the connections when being out on the road or in the field and professional repair/ maintenance is out of reach.

These repair kits contain fittings in the most common sizes, the necessary release tools, as well as a tube cutting device.

The TRUCK-DCASE is completed with a short and clearly understandable working instruction.



### MODEL TRUCK-DCASE/9000

Repair kit with Series C-Truck fittings

The kit is supplied with:

2x 9580 6	1x DRK 6	1x PNZP-12
2x 9580 8	1x DRK 8	
2x 9580 10	1x DRK 10	
2x 9580 12	1x DRK 12	



### MODEL TRUCK-DCASE/6000

Repair kit with Series 6000 fittings

The kit is supplied with:

2x 6580 4	2x 6580 10	1x PNZP-12
2x 6580 5	1x 6580 12	
2x 6580 6	1x 6580 14	
2x 6580 8		



### MODEL TRUCK-DCASE/9000+6000

Repair kit with Series C-Truck and Series 6000 fittings

The kit is supplied with:

1x 6580 4	2x 6580 10	2x 9580 6	1x DRK 6
1x 6580 5	1x 6580 12	2x 9580 8	1x DRK 8
1x 6580 6	1x 6580 14	1x 9580 10	1x DRK 10
1x 6580 8		1x 9580 12	1x DRK 12
			1x PNZP-12



## Contacts

**Camozzi Automation S.p.A.**

Società Unipersonale  
Via Eritrea, 20/I  
25126 Brescia  
Italy  
Tel. +39 030 37921  
info@camozzi.com



Automation

