



02
utensilios · utensils



U.P.

INOX
Dishwasher

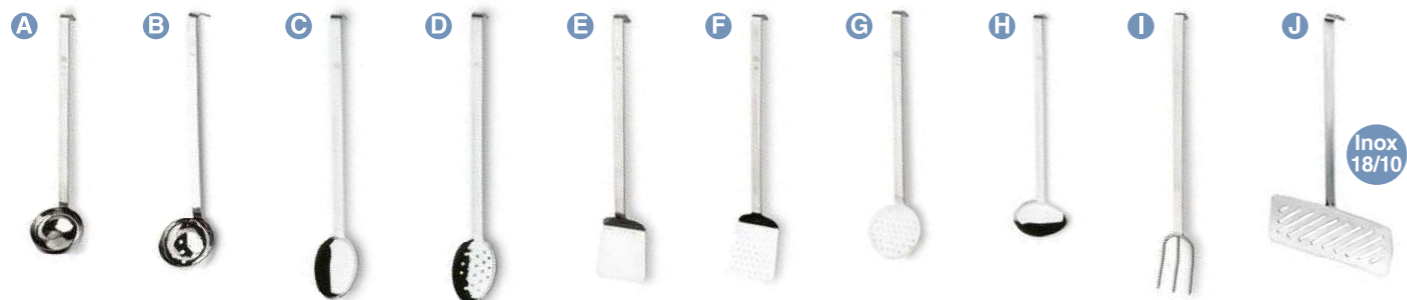

Inox
18/10

Ref	€	Ø (cm)	Largo (cm)	L	U.Venta
60306	10,50	6,50	34,5	0,07	6
60308	12,00	8,00	38,0	0,12	6
60309	12,70	9,00	46,0	0,20	6
60310	14,40	10,00	46,0	0,25	6
60312	16,90	12,00	48,0	0,50	6
60314	21,70	14,00	55,0	0,75	6
60316	22,40	16,00	55,5	1,00	6
61308	11,30	8	38,0	0,12	6
61310	14,60	10	46,0	0,25	6
61312	17,40	12	48,0	0,50	1
60507	11,30	10,5	48,0	-	1
60508	13,70	7,50	48,0	-	6
61410	12,60	9x10	49,5	-	6
61412	14,30	11x12	51,0	-	6
61411	13,60	9x10	49,50	-	6
61413	14,80	11x12	51,0	-	6
60408	10,00	8	35,0	-	1
60410	12,00	10	47,0	-	6
60412	12,60	12	49,5	-	6
60414	16,90	14	57,0	-	6
60416	18,50	16	57,0	-	6
60509	14,80	8x10	34,5	0,07	1
60002	15,80	7x8	57,5	2 puntas	6
60003	17,60	7x13	57,5	3 puntas	6
62988	20,40	20,5x8	37,0	-	12

Cacillo · Louche · Ladle

Cacillo perforado · Louche perforée · Perforated ladle

Cuchara · Cuillère · Ladle

Cuchara perforada · Cuillère perforee · Perforated ladle

Espátula · Spatule · Spatula

Espátula perforada · Spatule perforee · Perforated spatula

Espumadera · Ecumoire · Skimmer

Cuchara oblicua · Cuillère oblique · Crosswire spoon

Tenedor · Fourchette · Fork

Paleta de pescado · Pelle à poisson · Fish turner

Fabricado íntegramente en acero inoxidable
Handle made of 18/10 stainless steel



Espumadera alambre Chef Inox
Ecumoire à friture · Fritierlöffel
Skimmer · Escumadeira arame

Ref	€	Ø (cm)	Largo (cm)	U.Venta
60409	13,20	10	47,0	6
60411	14,30	12	49,0	6
60413	17,20	14	50,5	6
60415	18,90	16	52,0	6
60417	22,30	18	58,0	6
60419	26,60	20	59,0	6
60423	33,60	24	71,5	6
60427	39,30	28	74,0	6

Espumadera alambre
Ecumoire etamee · Fritierschaufel
Tinned skimmer · Escumadeira de arame

Ref	€	Ø (cm)	Largo (cm)	U.Venta
63514	12,20	14	54,0	1
63516	13,00	16	56,5	1
63518	13,50	18	56,5	1
63520	16,80	20	67,0	1
63524	18,50	24	70,5	1
63528	21,90	28	76,0	1

Alambre estañado/Fil étamé/Tinned wire

INOX
18/10

Rasera alambre
Araignée à fil · Fritierlöffel
Mesh skimmer · Escumadeira arame

Ref	€	Ø (cm)	Largo (cm)	U.Venta
67410	14,30	10	37,0	6
67412	19,40	12	44,0	6
67415	31,10	15	55,5	6
67417	36,30	17	56,0	6
67420	44,50	20	58,0	6

Buffet

INOX
18/10
Dishwasher



Ref	€	cm	Largo (cm)	U.Venta
72853	11,60	Ø6	24,5	6
72857	10,70	5x8	27,5	6
72858	10,70	5x8	27,5	6
72854	12,90	Ø8	27,0	6
72859	11,60	7x9	28,5	6
72850	11,60	5x7,5	23,5	6
72851	11,10	6x8,5	28,0	6
72856	11,60	6,5x11	31,5	6
72855	9,40	4,5x9	28,5	6

Cacillo · Louche · Ladle

Cuchara · Cuillère · Ladle

Cuchara perforada · Cuillère perforee · Perforated ladle

Espumadera · Ecumoire · Skimmer

Espátula perforada · Spatule perforee · Perforated spatula

Cacillo salsa · Louche sauce · Gravy ladle

Pala ensalada · Pelle à salade · Dalat scoop

Pala pastel · Pelete à gâteau · Cake scoop

Tenedor · Fourchette · Fork



Profesional

INOX 18/10
Dishwasher



	Ref	€	cm	Largo (cm)	U.Venta	
A	72803	21,30	Ø10	37,0	6	Cacillo · Louche · Ladle
B	72807	15,80	7x11	36,0	6	Cuchara · Cuillère · Ladle
C	72808	16,10	7x11	35,5	6	Cuchara perforada · Cuillère perforee · Perforated ladle
D	72806	15,30	9x12	39,0	6	Espátula · Spatule · Spatula
E	72809	17,20	9x12	39,0	6	Espátula perforada · Spatule perforee · Perforated spatula
F	72804	17,70	Ø11	37,0	6	Espumadera · Ecumoire · Skimmer
G	72805	14,40	3x10	35,5	6	Tenedor · Fourchette · Fork
H	72810	16,00	Ø6,5	29,0	6	Cacillo salsa · Louche sauce · Gravy ladle
I	72811	16,50	6,5x9	34,0	6	Servidor espaguetis · Cuillère à spaguetis · Spaguetti server

Monoblock

INOX
Dishwasher



	Ref	€	cm	Largo (cm)	U.Venta	
A	62503	8,40	Ø9	31,5	1	Cacillo · Louche · Ladle
B	62507	6,80	6,5x10	34,5	1	Cuchara · Cuillère · Ladle
C	62504	8,50	Ø11,5	35,0	1	Espumadera · Ecumoire · Skimmer
D	62506	6,60	8x10	35,5	1	Espátula · Spatule · Spatula
E	62505	5,70	2,5x10	33,5	1	Tenedor · Fourchette · Fork

Due

PA Nylon INOX 18/10 SI Silicene Dishwasher BPA free



	Ref	€	cm	Largo (cm)	U.Venta	
A	68270	8,60	7x10,5	36,5	6	Cuchara · Cuillère · Ladle
B	68271	8,80	10,5x9,5	33,5	6	Cacillo · Louche · Ladle
C	68272	8,60	10,5x10,5	36,5	6	Espumadera · Ecumoire · Skimmer
D	68274	8,80	8,5x10,5	37,5	6	Espátula · Spatule · Spatula
E	68275	8,70	8,5x10,5	37,5	6	Espátula perforada · Spatule perforee · Perforated spatula
F	68273	8,30	6,5x9,5	36,5	6	Servidor espaguetis · Cuillère à spaguetis · Spaguetti server
G	68276	8,80	8x14,5	36,5	6	Paleta de pescado · Pelle à poisson · Fish turner

Super Monoblock

INOX 18/10
Dishwasher

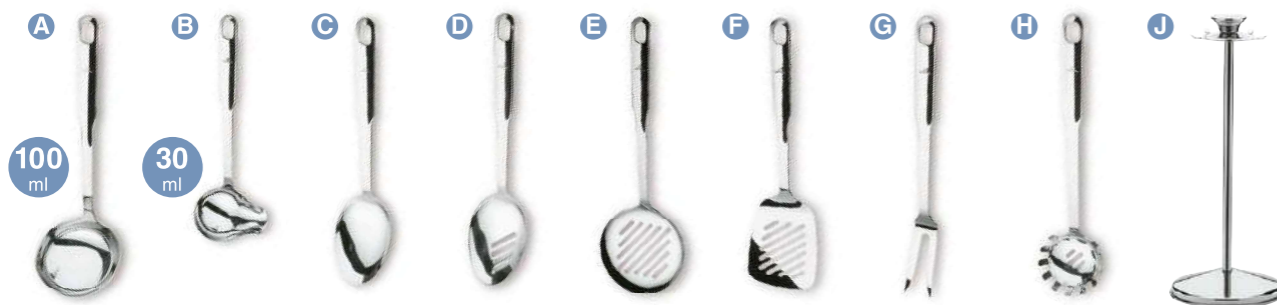

	Ref	€	cm	Largo (cm)	U.Venta	
A	62603	17,30	Ø10	31,0	6	Cacillo · Louche · Ladle
B	62609	15,10	7x9	31,0	1	Cacillo salsa · Louche sauce · Gravy ladle
C	62607	12,90	7x10	32,0	6	Cuchara · Cuillère · Ladle
D	62608	12,10	7x10	32,0	1	Cuchara perforada · Cuillère perforee · Perforated ladle
E	62604	17,30	Ø11	36,5	6	Espumadera · Ecumoire · Skimmer
F	62606	12,60	8x9	33,5	6	Espátula · Spatule · Spatula
G	62605	11,00	3x8	33,5	1	Tenedor · Fourchette · Fork
H	62811	14,40	Ø7,5	31,0	6	Servidor espaguetis · Cuillère à spaguetis · Spaguetti server
I	62601	92,60	-	-	1	Juego 5 piezas · 5 utensiles de cuisine · 5 pds. kichen tools
J	62630	24,60	40	-	1	Soporte juego · Soutien · Hangring rack



I Cacillo (62603)
Espumadera (62604)
Tenedor (62605)
Espátula (62606)
Cuchara lisa (62607)



Eco

PA Nylon Dishwasher BPA free



Ref	€	cm	Largo (cm)	U.Venta
-----	---	----	------------	---------

A	98803	5,20	Ø9,5	29,0	12	Cacillo · Louche · Ladle
B	98807	4,40	7,5x10	30,5	12	Cuchara · Cuillère · Ladle
C	98808	4,10	7,5x10	30,5	12	Cuchara perforada · Cuillère perforee · Perforated ladle
D	98804	4,90	Ø11	31,5	12	Espumadera · Ecumoire · Skimmer
E	98806	4,50	8x10	33,0	12	Espátula perforada · Spatule perforee · Perforated spatule
F	98810	3,90	8x6,5	27,0	12	Cacillo salsa · Louche sauce · Gravy ladle
G	98811	4,00	Ø7,5	29,0	12	Servidor espaguetis · Cuillère à spaguetis · Spaguetti server

Black

PA Nylon Dishwasher BPA free



Ref	€	cm	Largo (cm)	U.Venta
-----	---	----	------------	---------

A	98903	3,90	8x9,5	31,0	12	Cacillo · Louche · Ladle
B	98907	3,90	6,5x10	30,0	12	Cuchara · Cuillère · Ladle
C	98908	3,90	6,5x9	30,0	12	Cuchara perforada · Cuillère perforee · Perforated ladle
D	98905	3,90	7,5x9	25,0	12	Cuchara salsa · Cuillère sauce · Gravy spoon
E	98906	3,90	9x10	31,0	12	Espátula perforada · Spatule perforee · Perforated spatule
F	98912	3,90	8x12	28,0	12	Espátula corta · Spatule court · Short spatule
G	98913	3,90	4x7	31,0	12	Espátula larga · Spatule longue · Long spatule
H	98904	3,90	Ø11	33,0	12	Espumadera · Ecumoire · Skimmer
I	98910	3,90	6x8,5	27,0	12	Cacillo salsa · Louche sauce · Gravy ladle
J	98911	3,90	6x8	30,0	12	Servidor espaguetis · Cuillère à spaguetis · Spaguetti server
K	98909	3,90	8x16	32,0	12	Paleta de pescado · Pelle à poison · Fish turner
L	98914	3,90	7x7	30,0	12	Batidor · Fouet · Whisk

Grey

SI Silicone FE Iron LFGB Food Grade Silicone Dishwasher BPA free



Núcleo reforzado para una mayor resistencia sin perder flexibilidad en los bordes. Diseñados en una sola pieza, sin costuras ni grietas
Reinforced core improves strength without losing flexibility around the edges. Designed in a single piece without seams or cracks

Ref	€	cm	Largo (cm)	U.Venta
-----	---	----	------------	---------

A	64466	7,90	Ø9,5	29,0	1	Cacillo · Louche · Ladle
B	64469	7,00	5,6x9,5	29,0	1	Cuchara · Cuillère · Ladle
C	64467	7,90	Ø9	29,0	1	Espumadera · Ecumoire · Skimmer
D	64468	7,00	7,5x9,5	29,0	1	Espátula perforada · Spatule perforee · Perforated spatule
E	64470	7,70	5,5x9,5	27,0	1	Servidor espaguetis · Cuillère à spaguetis · Spaguetti server
F	64471	7,00	4x12,5	27,0	1	Espátula estrecha · Spatule étroite · Narrow spatule
G	64462	7,90	-	29,0	1	Pinza larga · Pince longue · Long tong
H	64463	5,60	-	27,5	1	Cuchara · Cuillère · Ladle
I	64464	5,60	5,5x8	27,5	1	Espátula · Spatule · Spatula
J	64465	5,70	-	27,5	1	Pincel · Pinceau · Brush

Brun

HAYA Wood Dishwasher

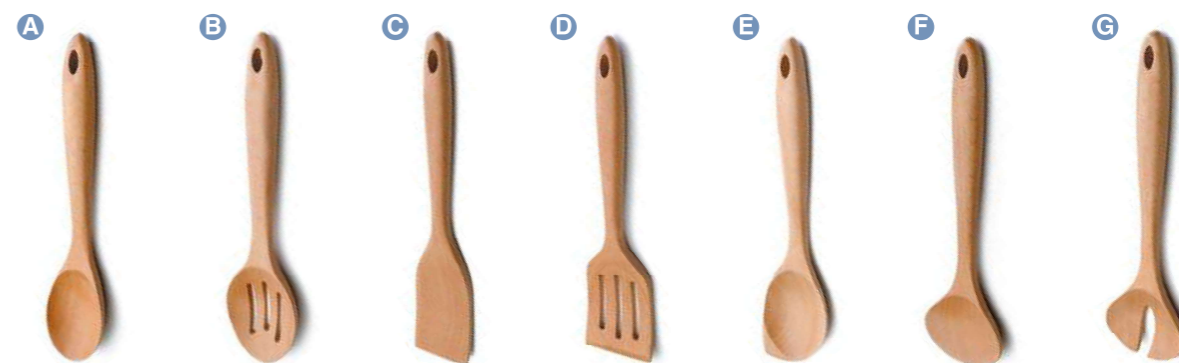

Ref	€	cm	Largo (cm)	U.Venta
-----	---	----	------------	---------

A	68175	6,20	6x10	30,0	6	Cuchara · Cuillère · Ladle
B	68176	6,50	7x10	30,0	6	Cuchara perforada · Cuillère perforee · Perforated ladle
C	68177	6,20	6,5x10	30,0	6	Espátula · Spatule · Spatule
D	68178	6,40	7,5x12	30,0	6	Espátula perforada · Spatule perforee · Perforated spatule
E	68179	6,70	6,5x10	30,0	6	Cuchara especial · Cuillère spécial · Special spoon
F	68173	7,20	8x7	30,0	6	Cuchara ensalada · Cuillère à salade · Salad spoon
G	68174	7,20	8x7	30,0	6	Tenedor ensalada · Fourchette à salade · Salad fork



Unite

SI HAYA
Silicone Wood
Dishwasher BPA free



130 ml

	Ref	€	cm	Largo (cm)	U.Venta
A	68187	6,90	Ø8	31,5	1
B	68185	6,00	6,7x10,5	32	1
C	68195	4,40	5,6x8,5	26,5	1
D	68186	6,10	7,5x10,5	33,5	1
E	68188	7,00	Ø11,5	33,5	1
F	68189	6,10	5,5x9,5	32,5	1
G	68196	4,20	5,5x0,5	24,5	1
H	68197	4,30	-	14,5	1
I	68198	4,30	-	14,5	1
J	68199	6,10	-	27,0	1

Cacillo · Louche · Ladle
Cuchara · Cuillère · Ladle
Espátula · Spatule · Spatula
Espátula perforada · Spatule perforee · Perforated spatula
Espumadera · Ecumoire · Skimmer
Servidor espaguetis · Cuillère à spaguetis · Spaguetti server
Pincel · Pinceau · Brush
Pelador liso · Éplucheuse plate · Peeler plain blade
Pelador dentado · Éplucheuse dentelé · Serrated peeler
Batidor · Fouet · Whisk

BBQ

INOX
Dishwasher



Maletín rectangular portátil con el interior forrado.
Composición: espátula, tenedor, cuchillo, pinza dentada y brocha
 Portable rectangular case with lined interior.
 Composition: spatula, fork, knife, serrated tongs and brush



5 pcs.

Maletín
 Malette · Koffer
 Briefcase · Maleta

Ref	€	cm	U.Venta
60260	48,00	47x16,6x8	1

Tenedor
 Fourchette · Tranchiergabel
 Fork · Garfo

Ref	€	Largo (cm)	U.Venta
60261	5,20	43,5	1

Cuchillo
 Couteau · Messer
 Knife · Faca

Ref	€	Largo (cm)	U.Venta
60262	5,00	41,5	1

BBQ Nordic

INOX RUBBER WOOD

Mango de madera de caucho con un acabado barnizado
 Rubberwood handle with a varnished finish.

Práctica cuerda de cuero para colgar
 It has a leather cord for hanging

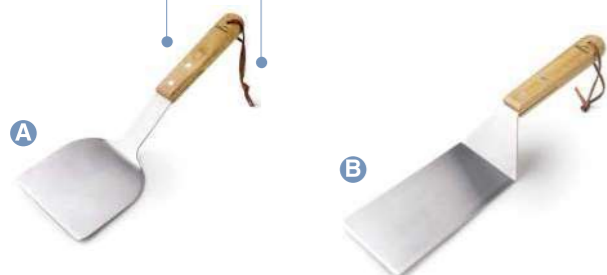

Espátula acodada
 Spatule coudée · Gewinkelter Spachtel
 Angled spatula · Espátula angular

	Ref	€	Largo (cm)	U.Venta
A	60268	4,80	30,5	1
B	60269	5,20	34,0	1

Espátula
 Spatule · Schaufel
 Spatule · Espátula

Ref	€	Largo (cm)	U.Venta
60263	8,30	45,5	1

Brocha
 Broche · Bürstes
 Brush · Escova

Ref	€	Largo (cm)	U.Venta
60264	6,30	44,0	1

Pinza
 Pincs · Zange
 Tong · Pinça

Ref	€	Largo (cm)	U.Venta
60265	10,20	43,5	1

Accesorios · Accessoires · Accessories

Espátula acodada
 Spatule coudées · Winkelpalette
 Bent spatule · Espátula comprida

Ref	€	Largo (cm)	U.Venta
60266	6,00	28,0	1

Cepillo de limpieza
 Brosse de nettoyage · Reinigungsbürste
 Cleaning brush · Escova de limpeza

Ref	€	Largo (cm)	U.Venta
60267	7,00	45,0	1



Utensilios Varios

INOX
18/10
Dishwasher



Sección cuadrada
(2,5x2,5 mm)
Square section



Pincho moruno 6u
Brochette carne en inox. (6) · Fleischspiesse (6), Rostfrei
St. steel skewers square wire (6) · Espeto moruno Inóx (6)

Ref	€	Largo (cm)	U.Venta
62446	5,00	20,0	12
62435	5,70	30,5	12
62445	6,80	40,5	12



INOX

Contenedor cubiertos
Panier à couverts · Besteckköcher
Cutlery holder · Copos para talheres

Ref	€	Ø (cm)	h(cm)	L	U.Venta
62962	21,60	12	13,6	1,40	1
62963	25,10	12	18,7	2,00	1



6 ganchos carnicero
6 crochets de boucher · 6-Tig Metzgerhaken
6 butchers hook · 6 ganchos de carnicero

Ref	€	Puntas	Ø (mm)	Largo (cm)	cm	U.Venta
39043	12,00	1	5	12,5	3,7	4
39044	18,60	1	5	18,5	4,5	1
39047	12,10	2	5	12,5	3,7	4
39048	18,80	2	5	18,5	4,5	1



Cuchara apoya utensilios
Cuillère ramasse ustensiles · Vorlegelöffel
Spoon holder utensils · Colher recolhe utensilios

Ref	€	cm	Largo (cm)	U.Venta
62972	11,80	25x12	25	1



AL
Aluminium

Barra sujeción notas
Barre à notes · Zettelhalter
Order rall · Barra fixação notas

Ref	€	Largo (cm)	U.Venta
60731	12,00	30,50	1
60746	15,60	46,00	1
60761	18,70	61,00	1
60776	21,60	76,00	1
60791	26,80	91,50	1

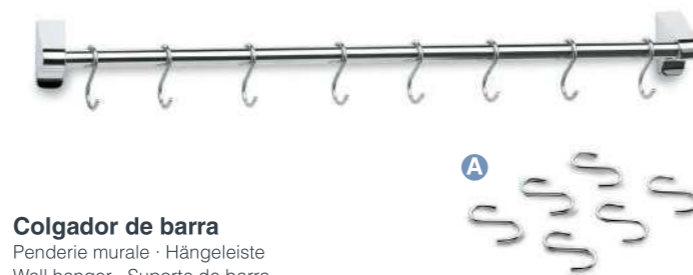

Colgador de barra
Penderie murale · Hängeleiste
Wall hanger · Suporte de barra

Ref	€	Unidades	Largo (cm)	U.Venta
60740	23,10	6	40	1
60760	31,90	8	60	1
60710	44,10	12	100	1
A 60700	6,90	6	-	12

Juego 6 ganchos
6 hook set

Preparación

Food processing



Espátulas

INOX Dishwasher



Espátula de pescado Flex

Spatule flexible à poisson · Fisch Schaufel, flexible
Flexible spatula to fish · Espátula flexível para peixe

Ref	€	Largo (cm)	U.Venta
60426	4,50	30	6



INOX 18/10 Silicone BPA free

Espátula de pescado Pro

Spatule à poisson · Fischheber
Fish spatula · Espátula de peixe

Ref	€	Largo (cm)	U.Venta
60726	14,00	30	1



Espátula serrada

Spatule à gâteau · Backschaufel
Serrated spatula · Espátula com serra

Ref	€	cm	U.Venta
62677	9,00	30x5,5	6



Espátula grill

Spatule coudée our grill · Winkelpalette
Bent grillspatula · Espátula comprida grelha

Ref	€	cm	U.Venta
60434	6,10	12x27	6



Paleta triangular

Grattoir manche noir m/solide · Bratenspachtel, Stiel
Straight Scraper/turner · Espátula triangular cabo sólido

Ref	€	cm	U.Venta
60430	7,00	10x11,5	12



Espátula lisa Bent

Spatule lisse m/solide · Backschaufel, f. Festsoffe
Straight spatula · Espátula lisa cabo sólido

Ref	€	cm	U.Venta
60425	4,90	7x13,5	12



Espátula repostería

Pâtisserie spatule · Gebackpalette
Pastry spatula · Espátula pastelaria

Ref	€	cm	U.Venta
60443	4,10	6,5x14,5	12



Espátula para emplatar

Mini spatule coudée · Winkelpalette Mini
Mini bent spatula · Espátula mini comprida

Ref	€	cm	U.Venta
60442	3,80	2x9	12

New



Set 2 espátulas Mini

Ensemble de 2 spatules · Set mit 2 Spachteln
Set of 2 spatulas · Conjunto de 2 espátulas

Ref	€	A (cm)	B (cm)
60493	5,20	22,5	11,5

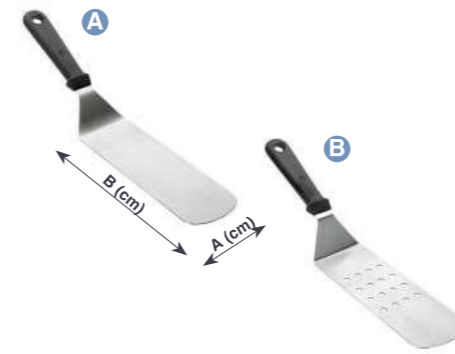

Espátula lisa Black

Spatule lisse m/solide · Spachtel, mit solidem Stiel
Straight spatula · Espátula lisa cabo sólido

Ref	€	AxB (cm)	U.Venta
A 60420	5,40	7,5x21,5	12
B 60421	5,30	7,5x21,5	12

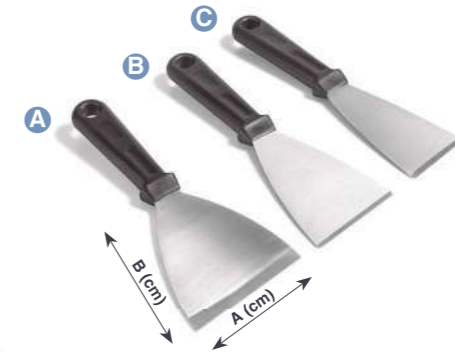

Espátula para plancha

Spatule m/solide · Grillspachtel, mit solidem Stiel
Straight spatula · Espátula grelha cabo sólido

Ref	€	A (cm)	B (cm)	U.Venta
A 60422	4,70	10	11,5	6
B 60445	4,00	8	11,5	6
C 60446	3,90	6	11,5	6



Espátula lisa Ring

Spatule manche noir · Schaufel mit schwarzem Stiel
Solid turner w/black H. · Espátula cabo negro

Ref	€	AxB (cm)	Largo (cm)	U.Venta
A 60435	7,80	7,5x17	35	6
B 60438	7,90	7,5x17	35	6



Espátula acodada

Spatule coudée · Winkelpalette
Bent spatula · Espátula comprida

Ref	€	cm	U.Venta
60482	4,00	4x15	12
60483	4,30	4x19	12
60484	4,60	4x24	12



Espátula larga acodada

Spatule longue coudée m/solide · Winkelpalette, lang
Long bent spatula · Espátula comprida c/cabo sólido

Ref	€	Largo (cm)	U.Venta
60467	4,00	20	12
60468	4,10	25	12
60469	4,20	30	12



Espátula larga recta

Spatule longue droite m/solide · Palette, lang, gerade
Long straight spatula · Espátula comprida c/cabo sólido

Ref	€	Largo (cm)	U.Venta
60461	3,80	15	12
60462	3,90	20	12
60463	4,00	25	12
60464	4,10	30	12
60465	4,20	35	12



INOX 18/10

Espátula gigante Inox

Spatule geante en Inox · Rührspatel, Edelstahl
St steel long handle Turner · Espátula gigante Inóx

Ref	€	Largo (cm)	U.Venta
61481	68,40	80	1
61421	74,80	120	1

PE Polyethylene

Pala profesional

Pelle professionnelle · Professionnelle Ruhrspatel
Professional shovel · Pá professional

Ref	€	Largo (cm)	U.Venta
60404	79,30	81,5	1



INOX ABS Plastic

Pala para patatas

Pelle à pommes de terre · Kartoffelschaufel
Potato shovel · Pá de batatas

Ref	€	cm	Nº Asas	U.Venta
A 62678	12,90	20x22	1	1
B 62679	15,20	20x22	2	1

Espátulas de silicona

SI **FE** 230°C LFGB BPA free
Silicone Iron Max Food Grade Silicone Dishwasher Dishwasher BPA free



FE
Iron

Utensilios Grey

Ustensiles en silicone · Silikonutensilien
Silicone utensils · Utensílios de silicone

	Ref	€	Largo (cm)	U.Venta
A	64463	5,60	27,5	1
B	64464	5,60	27,5	1
C	64465	5,70	27,5	1



Espátula silicona

Spatule en silicone · Teigschaber
Silicone spatula · Espátula de silicone

	Ref	€	Largo (cm)	U.Venta
A	64450	5,70	25	6
	64451	9,10	35	6
B	64460	6,00	25	6
	64461	10,00	35	6



Espátula White

Spatule en silicone · Teigschaber
Silicone spatula · Espátula de silicone

	Ref	€	Largo (cm)	U.Venta
	67421	4,70	20	1
	67427	7,00	26	1
	67433	15,30	32	1



FE
Iron

Utensilios Ocean

Ustensiles en silicone · Silikonutensilien
Silicone utensils · Utensílios de silicone

	Ref	€	Largo (cm)	U.Venta
Set	64452	17,20	27,5	1
A	64453	6,00	27,5	1
B	64454	6,00	27,5	1
C	64455	6,00	27,5	1



Espátula para tarros

Spatule pour pots · Spatel für Einmachgläser
Jar spatula · Espátula para frascos

	Ref	€	cm	Largo (cm)	U.Venta
	64490	2,50	3,8x8,4	25	1
	64491	4,10	4,8x10,8	35	1



Espátula Grey

Spatule en silicone · Teigschaber
Silicone spatula · Espátula de silicone

	Ref	€	Largo (cm)	U.Venta
	67434	4,80	30	12
	67435	5,60	29	12



Espátula Comfort

Spatule en silicone · Teigschaber
Silicone spatula · Espátula de silicone

	Ref	€	Largo (cm)	U.Venta
A	64444	6,10	28	1
B	64445	6,80	30	1
C	64446	6,90	31	1



Espátula profesional ExtraPlana

Spatula professionnelle · Profi-Spachtel
Professional spatula · Espátula profesional

	Ref	€	Largo (cm)	U.Venta
	61373	5,60	30	1
	61375	6,20	35	1
	61374	7,50	40	1



SI HAYA LFGB
Silicone Wood Food Grade Silicone

Espátula Unite

Spatule · Backschauffel
Spatule · Espátula

	Ref	€	cm	Largo (cm)	U.Venta
	68195	4,40	5,6x8,5	26,5	1

Set repostería- 20 pcs.
Exposant pâtisserie · Aufsteller Pastry
Pastry display · Expositor pastelería

	Ref	€	Largo (cm)	Piezas	U.Venta
A	64424	80,40	-	Caja (20 pcs.) · Set (20 pcs.)	1
B	64426	4,10	23,0	Pincel · Brush	12
C	64427	4,10	23,0	Espátula · Spatula	12
D	64428	4,10	23,0	Lengua gato · Spatula	12
E	64429	4,10	23,0	Batidor · Whisk	12



Rasquetas

INOX Dishwasher

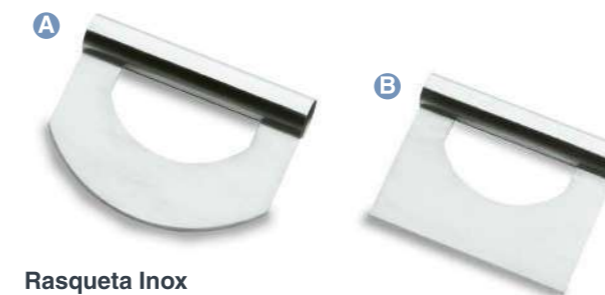

Rasqueta Inox

Coupe pate · Schaber
Scraper · Raspador

	Ref	€	cm	U.Venta
A	67005	13,20	15x9	6
B	67006	12,70	15x9	6



2 in 1

INOX
18/10

Rasqueta Inox Black

Coupe pate · Schaber
Scraper · Raspador

	Ref	€	cm	U.Venta
	67029	9,70	16,5x10,5	6

SI 230°C BPA free
Silicone Max BPA free



Rasqueta Flex

Coupe pate · Schaber
Scraper · Raspador

	Ref	€	cm	U.Venta
	67414	9,10	9x15	1

3 in 1



Flexible
Flexible

INOX PP
Polypropylene

SI BPA free
Silicone BPA free

Set rasqueta y recogedor

Coupe pate · Schaber
Scraper · Raspador

	Ref	€	cm	U.Venta
	67041	25,80	13,8x13	1

Diseño apilable
Stackable design



Pizza Collection

INOX
Oven



80 g

Ideal para salsa de tomate. Ofrece la porción ideal para pizzas estándar de 30 cm
Ideal for tomato sauce. Provides the ideal portion for standard 30 cm pizzas.



Cacillo salsa

Louche sauce · Saucengliesslöffel
Gravy ladle · Concha para molho

Ref	€	Ø (cm)	Largo (cm)	Capacidad	U.Venta
60562	5,70	7	27,0	80 g	1

Desmontable
Removable



FE
Iron

CRO
Cromado
Chrome



Soporte para hornear pizzas

Support avec plaques à pizzas · Pizza Backblech
Pizza baking rack · Suporte para cozer pizzas no forno

Ref	€	Bandejas	Ø (cm)	h(cm)	U.Venta
61462	24,90	4	29,5	21	1



INOX 18/10
ABS
Plastic



Pala Pizza

Pelle pizza · Pizzaschaufel, flach
Pizza flat scoop · Espátula pizza

Ref	€	cm	U.Venta
61461	14,40	25x36	1

INOX
18/10

Espátula pizza

Spatule pizza · Pizzaspatel
Pizza spatula · Espátula pizza



Ref	€	cm	U.Venta
60424	14,20	16,5x17,5x5	1



Mango desmontable
Removable handle

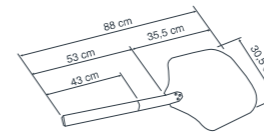

Pala pizza Wood

Pelle pizza · Pizzaofen-Schaufel
Pizza oven scoop · Pá de pizza

Ref	€	cm	Largo (cm)	U.Venta
61463	23,20	30,5x35,5	88	1

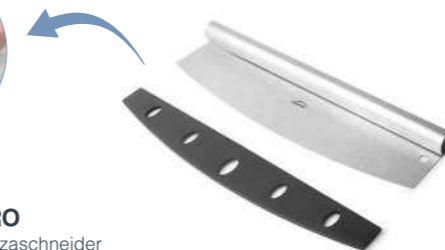

Cortapizza PRO

Roulette pizza · Pizzaschneider
Pizza cutter · Corta-Pizza

Ref	€	Largo (cm)	U.Venta
61465	7,70	35	1



Cortapizza Basic

Roulette pizza · Pizzaschneider
Pizza cutter · Corta-Pizza

Ref	€	Ø (cm)	U.Venta
60429	5,10	10	12



Cortapizza Plus

Roulette pizza · Pizzaschneider
Pizza cutter · Corta-Pizza

Ref	€	Ø (cm)	U.Venta
67028	12,40	10	1

Cortapizza Luxe

Roulette pizza · Pizzaschneider
Pizza cutter · Corta-Pizza

Ref	€	Ø (cm)	U.Venta
67004	18,00	10	1



Cortapizza Ergonomic

Roulette pizza · Pizzaschneider
Pizza cutter · Corta-Pizza

Ref	€	Ø (cm)	U.Venta
67027	6,00	8	6

- Pala pizza fabricada en aluminio anodizado de alta calidad.
- Ligera, robusta y manejable: ideal para un uso intensivo en cocinas profesionales.
- Base perforada: permite que el calor y la humedad escapen, evitando que la pizza se quede pegada a la pala y garantizando un deslizamiento suave y rápido. Esto ayuda a mantener la pizza crujiente y perfectamente cocida, sin perder su textura.
- Tamaño perfecto: la base amplia es ideal para pizzas de diferentes dimensiones.
- Su acabado anodizado le otorga una mayor durabilidad y resistencia a la corrosión.
- Mango largo y ergonómico: proporciona un agarre cómodo y seguro, permitiendo manejar las pizzas sin acercarse demasiado al horno y asegurando un control total.
- Ideal para hornos de leña, piedra o eléctricos.
- Fácil almacenamiento: con un agujero en el mango, esta pala de pizza puede colgarse fácilmente, ahorrando espacio y manteniendo el área de trabajo ordenada.

- Pizza oven scoop made of high-quality anodised aluminium.
- Lightweight, sturdy and easy to handle: ideal for intensive use in professional kitchens.
- Perforated base: Allows heat and moisture to escape, preventing the pizza from sticking to the peel and ensuring smooth and quick sliding. This helps to keep the pizza crispy and perfectly cooked, without losing its texture.
- Perfect size: The wide base is ideal for pizzas of different sizes.
- Its anodised finish gives it greater durability and resistance to corrosion.
- Long, ergonomic handle: provides a comfortable and secure grip, allowing you to handle pizzas without getting too close to the oven and ensuring total control.
- Ideal for wood-fired, stone or electric ovens.
- Easy storage: With a hole in the handle, this pizza peel can be easily hung up, saving space and keeping the work area tidy.

New

AL
Aluminium



Pala pizza Fuoco

Pelle pizza · Pizzaofen-Schaufel
Pizza oven scoop · Pá de pizza

Ref	€	cm	Largo (cm)	U.Venta
61466	52,80	30x30	120	1
61464	63,80	40x40	130	1





Batidores

INOX 18/10
Dishwasher

INOX

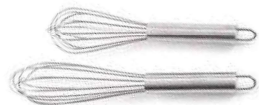

Batidor mini

Mini fouet Inox · Mini-Schneebeesen
Mini whisk · Mini batedor Inóx

Ref	€	Largo (cm)	U.Venta
61615	5,60	15	12
61620	6,20	20	12

Batidor Extra 8

Fouet inox extra 8 · Schneebeesen, Extra 8
Extra 8 whisk · Batedor Extra 8

Ref	€	Largo (cm)	U.Venta
61625	8,70	25	6
61630	8,90	30	6
61635	9,30	35	6
61640	10,30	40	6
61645	11,10	45	6
61650	12,40	50	6
61655	13,20	55	6
61660	14,20	60	6

Batidor Super 12

Fouet inox super 12 · Schneebeesen, super 12
Super 12 whisk · Batedor Super 12

Ref	€	Largo (cm)	U.Venta
61626	8,00	25	6
61631	8,60	30	6
61636	9,30	35	6
61641	9,90	40	6
61646	10,20	45	6
61651	11,10	50	6

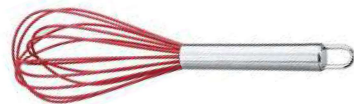

SI 250°C
Silicone Max
LFGB Food Grade Silicone
BPA free

Batidor varilla silicona

Fouet en silicone · Ruhrbesen auf Silikon
Silicone wire whisk · Batedor vareta silicone

Ref	€	Largo (cm)	U.Venta
61621	8,20	20	12
61622	9,10	25	6
61623	10,20	30	12



Batidor gigante

Fouet à purée · Kesselbesen
Big whisk · Batedor gigante

Ref	€	cm	Diámetro varilla (mm)	U.Venta
60610	64,10	100	3	12
60612	82,20	129	3	12

Raspador de silicona incorporado
Built-in silicone scraper

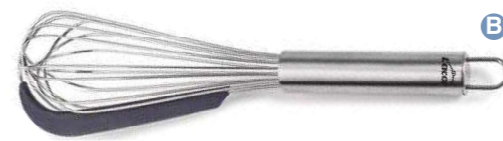

INOX 18/10
SI Silicone
HAYA Wood
LFGB Food Grade Silicone
Dishwasher
BPA free

Batidor varilla con espátula

Fouet avec grattoir · Schneebeesen mit Schaber
Whisk with spatula · Batedeira de varas com espátula

Ref	€	Largo (cm)	U.Venta
A 68199	6,10	27,0	1
B 61627	6,40	32,0	12

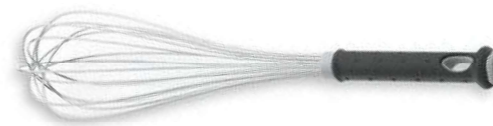

INOX 18/10
Fibra de vidrio Fibreglass

Batidor Fibreglass

Fouet · Schneebeesen
Whisk · Batedores

Ref	€	Largo (cm)	U.Venta
61624	12,10	25	6
61629	14,00	30	6
61634	15,80	35	6
61639	17,50	40	6
61644	21,00	45	6
61649	22,00	50	6



INOX

Batidor Manivela

Batteur-mélangeur à manivelle · Schneequirl
Egg beater · Batedor de manivela

Ref	€	U.Venta
62901	19,60	6

- Batidor de varilla con práctico raspador de silicona incorporado.
- 2 en 1: bate y recoge toda la mezcla del bol de forma fácil y rápida.
- Varillas fabricadas en acero inoxidable.
- Espátula de silicona inyectada en una de las varillas (certificado LFGB y libre de BPA).

- Fouet avec racloir en silicone intégré très pratique.
- 2 en 1: fouette et récupère facilement et rapidement tout le mélange dans le bol.
- Baguettes en acier inoxydable.
- Spatule en silicone injectée dans l'une des baguettes (certifiée LFGB et sans BPA).

- Hand whisk with practical built-in silicone scraper.
- 2 in 1: whisk and collect all the mixture from the bowl quickly and easily.
- Whisk blades made of stainless steel.
- Silicone spatula moulded into one of the whisk blades (LFGB certified and BPA free).

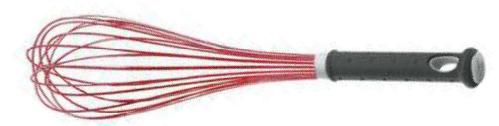

SI 250°C
Silicone Max
BPA free

Batidor silicona Fibreglass

Fouet en silicone · Schneebeesen, Silikon
Silicone whisk · Batedores silicona

Ref	€	Largo (cm)	U.Venta
61524	11,10	25	6
61529	12,00	30	6
61534	14,00	35	6



INOX ABS Plastic
Dishwasher
BPA free

Batidor Capuccino

Batteur pour cappuccino · Capuccino-Mixer
Capuccino mixer · Batedor capuccino

Ref	€	W	U.Venta
69041	27,40	2,7	1



Coladores

Posibilidad de completar colador en 4 sectores solicitando 4 unidades
Possibility of completing strainer in 4 sectors requesting 4 units

INOX 18/10
Dishwasher

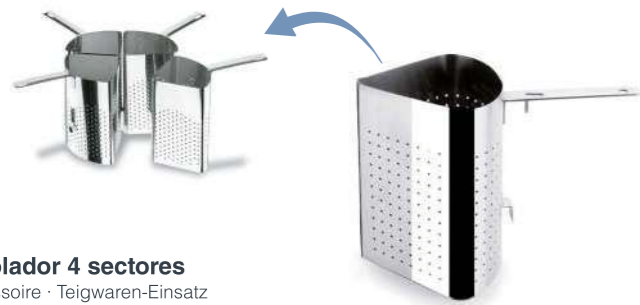

Colador tipo cazo

Passoire à queue · Seihier mit Stiel
Strainer · Coador



Ref	€	Ø (cm)	h(cm)	L	U.Venta
50320	57,20	20	12	3,5	1
50324	65,20	24	14	6,5	1
50328	76,40	28	15	9,3	1

Colador 4 sectores

Passoire · Teigwaren-Einsatz
Colander · Coador

Ref	€	Ø (cm)	h(cm)	U.Venta
50334	71,40	36	23,0	1



Colador chino

Passoire "Chinois" · Spitzsieb mit Flachstiel
"Chinese" strainer · Passador chinês

Ref	€	Ø (cm)	U.Venta
60311	17,80	10	1
60313	18,30	12	1
60315	19,20	14	1
60317	21,00	16	1
60318	22,20	18	1
60320	24,00	20	1
60322	26,10	22	1
60324	27,40	24	1
60326	29,40	26	1

Colador chino con pestaña

Passoire "Chinois" manche fil · Spitzsieb mit Rundstiel
Wire handle "Chinese" strainer · Passador chinês cabo vareta

Ref	€	Ø (cm)	U.Venta
60316P	17,60	16	1
60318P	18,80	18	1
60320P	20,20	20	1
60322P	22,90	22	1
60324P	24,40	24	1

Colador chino sin pestaña

Passoire "Chinois" manche fil · Spitzsieb mit Rundstiel
Wire handle "Chinese" strainer · Passador chinês cabo vareta

Ref	€	Ø (cm)	U.Venta
60316V	18,30	16	1
60319V	20,70	20	1



INOX

Colador chino de malla

Passoire "Chinois" toile-metallique · Gazespitzsieb
Meshed "Chinese" strainer · Coador chinês de rede

Ref	€	Ø (cm)	U.Venta
60319	28,60	18	1
60321	35,40	20	1
60323	35,80	22	1
60325	39,30	24	1

Colador malla c/refuerzo

Chinois toile-metallique a croisillon
Gewebedurchschlang, konisch, verstärkt
Conical mesh strainer w/protection · Coador de rede c/reforço

Ref	€	Ø (cm)	U.Venta
62621	54,20	20x22	1



Colador 1/2 esfera

Passe-bouillon · Passiersieb
Sieve · Coador 1/2

Ref	€	Ø (cm)	U.Venta
62680	5,30	8	1
62610	8,90	10	1
62612	11,50	12	1
62614	13,20	14	1
62616	15,60	16	1
62618	18,30	18	1
62620	23,70	20	1
62623	28,50	23	1

Colador Cónico

Passoire conique · Passiersieb, konisch
Conical sieve · Coador cónico

Ref	€	Ø (cm)	U.Venta
62690	7,20	8	1
62611	9,60	10	1
62613	12,30	12	1
62615	15,40	14	1
62617	18,20	16	1
62619	21,10	18	1

Nidos de alambre

Panier à nid · Nestbacklöffel
Bird's nest mould · Ninhos de arame

Ref	€	cm	Largo (cm)	U.Venta
62957	23,20	7-9	35	1
62959	27,10	9-11	37	1

HAYA Wood
Dishwasher



Mano chino

Poussoir à chinois · Holz-Stößel
Chinesse strainer pusher · Pilão p/passador chinês

Ref	€	Largo (cm)	U.Venta
60300	6,30	25	1

Alambre estañado
Tinned wire

Mango de madera
Wooden handle



INOX

Colador doble malla

Passoir maillee · Passiersieb, stark
Mesh strainer · Coador rede dupla

	Ref	€	Ø (cm)	Largo (cm)	U.Venta
	61316	8,30	16	32,0	1
A	61318	9,70	18	34,0	1
	61320	11,30	20	37,0	1
	61323	28,80	23	56,0	1
B	61326	31,30	26	58,0	1
	61330	55,80	30	78,5	1
C	61335	67,30	35	84,0	1

PE Polystyrene
BPA free

Triángulo

Triangle · Dreieck
Triangle · Triângulo

Ref	€	U.Venta
60402	56,80	1

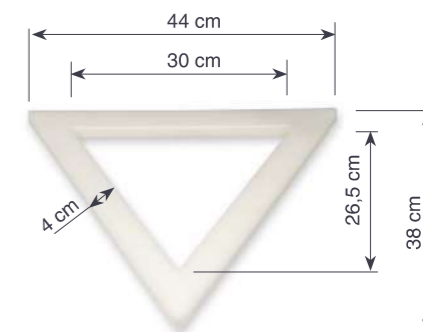



Escurridores

INOX
18/10
Dishwasher

100% plegable: ahorro de espacio
100% foldable: space saving



SI
Silicone
BPA free

Escurridor plegable

Passoire Pliable · Zusammenklappbares Sieb
Folding strainer · Escorredor dobrável

Ref	€	Ø (cm)	h(cm)	U.Venta
62884	14,80	24	10	1

Escurridor Inox

Passoire · Abtropfschale
Straine · Escorredor

Ref	€	Ø (cm)	h (cm)	U.Venta
62731	10,90	15	7,5	1
62732	18,50	22	9,5	1
62736	22,00	26	11,5	1

New



Escurridera con base

Passoire sur pied · Abtropfschüssel mit Fussreif
Colander with stand · Escorredora com base

Ref	€	Ø (cm)	h(cm)	L	U.Venta
50336	270,70	36	19	12,0	1
50340	317,10	40	21	14,5	1



Escurridera cónica con base

Passoire conique sur pied · Abtropfschüssel
Conical colander with stand · Escorredor cónico com base

Ref	€	Ø (cm)	h(cm)	L	U.Venta
50829	72,60	28	17	13,2	1
50833	79,70	32	20	14,5	1
50837	90,80	36	23	16,0	1
50841	98,30	40	26	18,0	1
50846	112,70	45	29	20,0	1
50851	128,20	50	33	22,0	1

garinox®

INOX

Escurridera Garinox

Passoire · Abtropfschüssel
Colander · Escorredor



Ref	€	Ø (cm)	L	U.Venta
14122	18,90	22	3,0	1
14125	23,20	25	5,0	1
14130	33,60	30	8,0	1



Escurridor extensible

Passoire extensible pour l'évier · Spülbank-Sieb, ausziehbar
Extendable sink strainer · Escorredor extensível para bancada

Ref	€	cm	U.Venta
62987	24,70	34x54	1

New

Ø41,5 cm



INOX

Escurridor de patatas Pro

Egouttoir à pommes de terre professionnel en acier inoxydable de haute qualité.
Potato drainer · Escorredor de batatas

Ref	€	Ø (cm)	h(cm)	U.Venta
62682	45,50	41,5	16,5	1

- Escurridor de patatas profesional fabricado en acero inoxidable de gran calidad.
- Asa lateral ergonómica para un manejo cómodo y seguro.
- Diseño de boca ancha, ideal para un uso intensivo.
- Perforaciones que permiten un drenado eficiente de grasas y exceso de especias.
- Fácil de limpiar gracias a su recipiente extraíble para el drenaje.

- Égouttoir à pommes de terre professionnel en acier inoxydable de haute qualité.
- Poignée latérale ergonomique pour une manipulation confortable et sûre.
- Conception à large ouverture, idéale pour un usage intensif.
- Perforations permettant une évacuation efficace des graisses et des excès d'épices.
- Facile à nettoyer grâce à son récipient amovible pour l'évacuation.

- Professional potato drainer made of high-quality stainless steel.
- Ergonomic side handle for comfortable and safe handling.
- Wide-mouthed design, ideal for intensive use.
- Perforations that allow efficient draining of fats and excess spices.
- Easy to clean thanks to its removable drainage container.

Malla metálica donde se depositan los alimentos. Agujeros 1x1 cm
Metal mesh where food is deposited. Holes 1x1 cm



Recipiente donde se recoge el aceite sobrante
Container where excess oil is collected

Escurrefritos

Passoire a friture · Abtropfschüssel für Frittiertes
Fry colander · Escorre-fritos

Ref	€	cm	h(cm)	U.Venta
50541	186,30	40x29	8,0	1
50551	219,70	50x39	8,0	1
50561	252,40	60x39	8,0	1

Ayuda a preparar rebozados perfectos
Helps prepare perfect batters



Harina tamizada, para su recuperación
Sifted flour, for its recovery

Harinero

Tamis à farine à glissière · Mehlbehälter
Flour bin mesh · Farinheiro

Ref	€	cm	h(cm)	U.Venta
50438	167,10	37x26,5	18	1
50450	172,50	50x26,5	18	1

Embudos

INOX 18/10
Dishwasher



- Embudo dosificador fabricado en acero inoxidable.
- Excelente resistencia a la corrosión, los ácidos alimentarios y sales.
- Capacidad 1,25 L.
- Ideal para rellenar o decorar platos con salsas y cremas calientes y frías.
- Sistema de palanca para un caudal ajustable; práctico y preciso. Boquilla de salida de 8mm.
- Mango con diseño ergonómico que permite el manejo con una sola mano.
- Incluye soporte de gran estabilidad.
- Fácil limpieza, apto para el lavavajillas.

- Automatic piston portioner funnel made of 18/10 stainless steel.
- Excellent resistance to corrosion, food acids and salt.
- 1.25 L capacity.
- Perfect for filling or decorating dishes with hot or cold sauces and cream.
- Its lever system for controlling the flow is practical and precise. 8 mm outlet nozzle.
- The ergonomic handle means it can be used with just one hand.
- Includes high stability base.
- It's easy cleaning and it's dishwasher safe.

INOX Dishwasher

Embudo Dosificador

Decor entonnoir · Doser dosiertrichter
Portionner funnel · Dosificador funil

Ref	€	Ø (cm)	h(cm)	L	U.Venta
67151	22,10	13,5	26	1,25	1

Ranura de desgasificación, Filtro

Degassing groove. Filter

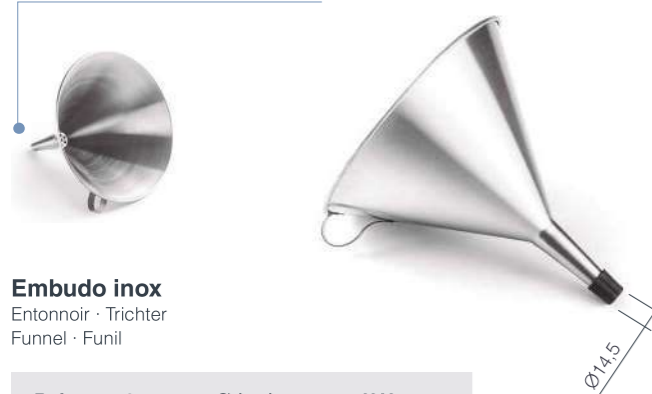

Embudo inox

Entonnoir · Trichter
Funnel · Funil

Ref	€	Ø (cm)	U.Venta
62512	16,10	12	1
62516	23,30	16	1
62521	30,20	20	1
62524	33,80	24	1

Cuello ancho para verter con mayor rapidez en tarros/botellas sin riesgo de quemaduras

Wide neck for faster pouring into jars / bottles without risk of burns



Embudo mermelada

Entonnoir à confiture · Mermeladentrichter
Funnel for jam · Funil de congestionamento

Ref	€	Ø (cm)	Ø inferior (cm)	h(cm)	U.Venta
62517	10,30	13,5	6	6,5	1

Ranura de desgasificación Filtro extraíble

Degassing groove. Removable filter



Embudo con filtro

Entonnoir à filtre mobile · Trichter mit Sieb
Funnel with movable filter · Funil com filtro

Ref	€	Ø (cm)	A (cm)	U.Venta
62531	13,20	10	1,2	1
62513	15,40	12	1,5	1
62515	17,70	14	1,5	1



Embudo expandible

Entonnoir extensible · Trichter
Foldable funnel · Funil extensível

Ref	€	Ø (cm)	h(cm)	U.Venta
68085	6,10	8	10,5	1

Hervidores

INOX 18/10
Dishwasher

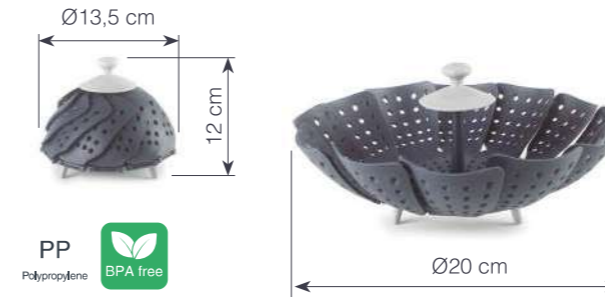
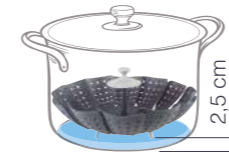

Hervidor extensible Flor

Panier marguerite extensible · Kocher, ausdehnbar, Rostfrei
Extensible steamer · Grelha extensível

Ref	€	Ø (cm)	h(cm)	U.Venta
60288	8,20	13,5-26	12	1

Diseñados para cocinar los alimentos al vapor preservando todos sus nutrientes y vitaminas. Se adapta a diferentes tamaños de ollas gracias a sus hojas plegables.
Designed to steam cook food while preserving all its nutrients and vitamins. Foldable, adapts to different pot sizes.



Hervidor extensible Inox

Panier marguerite extensible · Kocher, ausdehnbar, Rostfrei
Extensible steamer · Grelha extensível

Ref	€	Ø (cm)	U.Venta
60349	6,90	24	12
60348	10,10	28	12

- Cestillo de malla de alambre, fabricado en acero inoxidable de alta calidad.
- Perfecto para cocer pasta, raviolis, fideos, verduras, patatas, huevos y otros alimentos.
- Su mango largo fabricado en madera de haya permite retirar los alimentos de forma segura y sencilla.
- Incluye un gancho para colgarlo cómodamente en la olla.

- Panier cuiseur en fil métallique, fabriqué en acier inoxydable de haute qualité.
- Idéal pour cuire des pâtes, des raviolis, des nouilles, des légumes, des pommes de terre, des œufs et d'autres aliments.
- Sa longue poignée en bois de hêtre permet de retirer les aliments facilement et en toute sécurité.
- Comprend un crochet pour le suspendre facilement dans la casserole.

- Wire mesh steamer basket, made of high-quality stainless steel.
- Perfect for cooking pasta, ravioli, noodles, vegetables, potatoes, eggs and other foods.
- Its long beech wood handle allows you to remove food safely and easily.
- Includes a hook for convenient hanging in the pot.

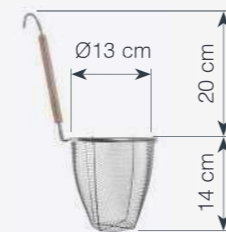

New

Cestillo cocedor pasta

Panier pour cuiseur de pâtes · Korb für Nudelkocher
Pasta cooker basket · Cesto para cozer massas

Ref	€	Ø (cm)	h(cm)	Mango (cm)	U.Venta
61314	4,30	13	14	20	1



Hervidor pescado

Poissonniere avec grille · Fischkochkessel mit Einsatz
Fish kettle with grill · Peixeira

Ref	€	cm	h(cm)	e (mm)	L	U.Venta
50440	105,60	40x19	11	0,8	10,05	1
50445	111,50	50x17	11	0,8	13,80	1
50460	145,60	60x19	11	0,8	20,80	1

Cuece especias

Diffuseur épices · Kräterkochsieb
Spice cooker · Cozedor de especiarias

Ref	€	Ø (cm)	h(cm)	U.Venta
62958	12,60	4	15,4	1

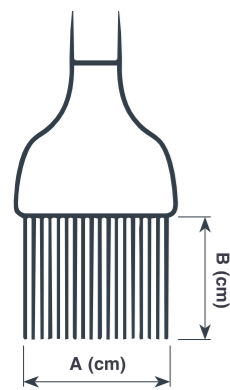

Pinceles

SI INOX 230°C
Silicone 18/10 Max
Dishwasher BPA free



Pincel de silicona Grey / Ocean

Pinceau · Silikonpinsel
Brush · Pincel

	Ref	€	Largo (cm)	U.Venta
A	64455	6,00	27,5	1
B	64465	5,70	27,5	1

Pincel de silicona Pro

Pinceau en silicone · Silikonpinsel
Silicon brush · Pincel silicone

	Ref	€	A (cm)	B (cm)	Largo (cm)	U.Venta
	64418	11,10	4,0	4,0	22	1
	64422	12,40	4,0	4,0	23	1



Pincel de silicona

Pinceau en silicone · Silikonpinsel
Silicon brush · Pincel de silicone

	Ref	€	A (cm)	B (cm)	Largo (cm)	U.Venta
	64441	6,90	5,8	3,4	23	1



Pincel Virola

Pinceau · Silikonpinsel
Brush · Pincel

	Ref	€	A (cm)	B (cm)	Largo (cm)	U.Venta
	64430	4,40	2,8	5,0	23,0	1
	64435	5,10	3,2	5,5	24,0	1
	64440	5,30	3,8	5,5	24,5	1
	65044	6,60	4,2	6,5	25,0	1
	65050	7,90	4,7	6,5	26,0	1



Dimensiones reales · Real dimensions

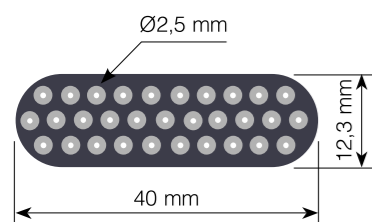

Pincel de silicona Mix

Pinceau de cuisine en silicone · Silikonpinsel
Silicone brush · Pincel de silicone

	Ref	€	A (cm)	B (cm)	Largo (cm)	U.Venta
	64431	7,40	3,8	4,0	24	12



Pincel de silicona Unite

Pinceau · Silikonpinsel
Brush · Pincel

	Ref	€	A (cm)	B (cm)	Largo (cm)	U.Venta
	68196	4,20	5,5	3,1	24,5	1



Huevo collection

INOX 18/10
Dishwasher



INOX Dishwasher

Separador de claras

Séparateur à oeuf · Eier-Separator
Eggs separator · Separador de ovos

Ref	€	h(cm)	U.Venta
61608	8,00	3,0	6

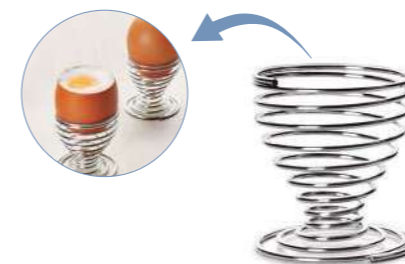

Molde huevo inox

Moule à oeufs-sandwich · Eier-/Sandwichring
Mould for egg-sandwich · Molde ovo-Sandwich

	Ref	€	cm	U.Venta
A	68005	3,30	Ø8,5	12
B	68006	3,30	8,5x8,5	12



Molde huevo

Moule à oeufs · Eierform
Egg mould · Molde ovo

	Ref	€	cm	h(cm)	U.Venta
A	68082	6,30	10,5x10,5	2,0	1
B	68080	6,30	Ø10	2,0	1

Soporte huevo Ovum

Support d'oeufs · Eierbecher
Egg stand · Suporte de ovo

Ref	€	Ø (cm)	h(cm)	U.Venta
68285	3,00	4,5	5	6



Garras de oso

INOX BAQUELITA
Bakelite Dishwasher



Garras de oso

Griffes à viande · Fleisch Bärenkrallen
Bear claws for meat · Garras de urso para carne

Ref	€	cm	U.Venta
38015	13,00	10,5x12	1

2 in 1

Manipula carnes. Desmenuza carnes · Manipulate meat. Crumble meats



Pasapurés

INOX 18/10
Dishwasher



Pasapurés
Presse-Puree · Passiergerät
Potato mashing machine · Passa-puré professional

	Ref	€	Ø (cm)	Diámetro disco (cm)	Cuchillas	L	U.Venta
A	60026	127,60	26	16,5	2	5,0	1
	60031	133,40	32	16,5	2	8,0	1
B	60030	84,60	30	16,5	2	3,5	1
	60048	56,60	18	10,5	3	0,7	1
C	60027	74,40	24	13,5	3	1,5	1
D	60021	57,40	20	11,5	2	1,5	1

- Fabricado en acero inoxidable 18/10 de alta calidad y gran resistencia.
- Tritura sin esfuerzo cualquier alimento cocinado previamente o de textura blanda.
- Ideal para preparar puré de patata, tomate, calabaza, plátano, etc.
- Superficie de prensado diseñado para conseguir un acabado homogéneo.
- No transmite olores ni sabores a los alimentos.

- Made of stainless steel 18/10 of high quality and great resistance.
- Crushing without effort Any food previously cooked or soft texture.
- Ideal to prepare potato puree, tomato, pumpkin, banana, etc.
- Pressing surface designed to get a homogeneous finish.
- It does not transmit odors or flavors to food.



Prensa patatas
Presse-pomme de terre · Kartoffelpresse
Potato press · Esmaga-batatas

Ref	€	cm	U.Venta
62902	35,80	9x28x11	1

Resultados perfectos en 4 pasos

Perfect results in 4 phases



Molde empanadillas
Moule à chaussons · Pastetenformen
Dumpling mould · Forma para salgados

Ref	€	Ø (cm)	U.Venta
68101	21,50	10	1
68102	23,50	12	1

Prensadores

INOX 18/10
Dishwasher



- Fabricado en acero inoxidable 18/10 de alta calidad y gran resistencia.
- Tritura sin esfuerzo cualquier alimento cocinado previamente o de textura blanda.
- Ideal para preparar puré de patata, tomate, calabaza, plátano, etc.
- Superficie de prensado diseñada para conseguir un acabado homogéneo.
- No transmite olores ni sabores a los alimentos.

- Fabriqu  en acier inoxydable 18/10 de grande qualit  et d'une r sistance maximale.
- Triture sans effort tout aliment pr alablement cuit ou   texture molle.
- Id al pour pr parer de la pur e de pomme de terre, de courge, de banane, etc.
- Surface de pressage con ue pour obtenir un r sultat homog ne.
- Ne transmet ni odeurs ni go ts aux aliments.

- Made of top quality, high resistance 18/10 stainless steel.
- Easily mashes any pre-cooked or soft-textured foods.
- Ideal for mashing potatoes, tomatoes, pumpkin, bananas, etc.
- Mashing surface designed for even mashing, giving perfect results.
- Does not transmit odours or flavours.
- Smooth round handle for a comfortable and secure grip.



Prensador de patatas
Presse-pur e · Kartoffelpresse
Potato masher · Prensa-batatas

	Ref	€	cm	h(cm)	U.Venta
A	62892	19,90	10,5x8,5	24	1
B	62896	18,40	�11,6	45,5	1
C	62897	8,70	11x7,5	17,5	1

2 in 1



Pica y lamina · Chop and slice



Accesorio para eliminar los restos
Accessory for eliminating the remains

ZAMAK
Zinc Alloy

Prensa ajos y laminador
Presse ail coupe · Knoblauchpresse, Schneider
Garlic press and slicer · Esmaga-alhos y laminador

Ref	€	Largo (cm)	U.Venta
60387	27,10	20	1

2 in 1

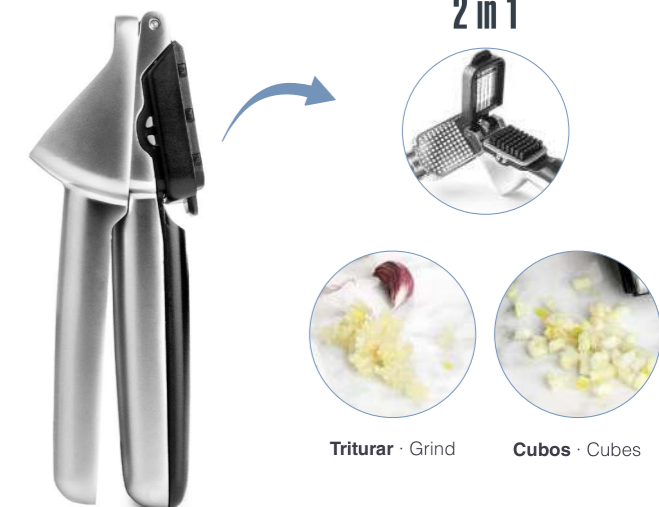

Triturar · Grind

Cubos · Cubes

ZAMAK ABS INOX
Zinc Alloy Plastic

Prensa ajos Dual
Presse ail coupe · Knoblauchpresse
Garlic press · Esmaga-alhos

Ref	€	h(cm)	U.Venta
60277	22,80	16	1

Click here



Prensa hamburguesas

500 Separadores Separators



Separadores · Separators



Resultados perfectos en 5 pasos · Perfect results in 5 steps

Incluye Includes 60 Separadores Separators



AL FUNDIDO INOX
Aluminium Cast 18/10

Prensa hamburguesas profesional
Presse à hamburguers · Hamburger-Formen
Hamburg presser · Moldes para hamburguesas

Ref	€	Hamburguesa Ø (cm)	U.Venta
60226	223,70	10	1
A R60226A	9,40	10	6
60227	243,70	13	1
A R60227A	9,90	13	6

Incluye Includes 60 Separadores Separators



AL FUNDIDO HAYA
Aluminium Cast Wood



Molde para hamburguesas Press
Presse à hamburguers · Hamburger-Formen
Hamburg presser · Moldes para hamburguesa

Ref	€	Ø (cm)	U.Venta
60258	15,00	11,5x7,5	1
R60258A	1,50	11	1

ABS Plastic BPA free

Molde para hamburguesas Multi
Presse à hamburguers · Hamburger-Formen
Hamburg presser · Moldes para hamburguesa

Ref	€	Ø (cm)	U.Venta
60259	7,50	12,5x6	1
R60259A	1,40	10	1



Superficie acanalada
Grooved surface



FE FUNDIDO ABEDUL
Iron Cast Birch



Prensador carne Magma
Presse à steak · Fleischpresse
Meat press · Prensador de carne

Ref	€	cm	h(cm)	U.Venta
A 25862	15,00	Ø17,5	8,0	1
B 25863	18,40	23x11	8,0	1

New

Rueda para mantequilla

INOX



Rueda para mantequilla Inox
Roue à beurre · Butterrad
Butter wheel · Roda de manteiga

Ref	€	cm	L	U.Venta
66001	41,50	GN 1/6	1,6	1

- Fabricada en acero inoxidable de alta calidad. Duradera y resistente al desgaste.
- Diseñada para untar mantequilla derretida de forma uniforme en rebanadas de pan o bollos.
- Cuenta con una gran capacidad (1,6 L) gracias a su cubeta GN 1/6 de 100 mm..
- Calienta el recipiente de manera rápida: simplemente colócalo sobre la plancha y permite que el calor derrita la mantequilla en su interior.
- Fácil de usar, solo necesitas girar suavemente la rueda y la mantequilla se extenderá de forma rápida y cómoda.
- La rueda es extraíble para facilitar una limpieza profunda.
- Su diseño ergonómico hace que su uso sea sencillo y eficiente, ahorrando tiempo en la cocina.

- Made of high quality stainless steel. Durable and wear resistant.
- Designed for spreading melted butter evenly on slices of bread or rolls.
- Large capacity (1.6 L) thanks to the 100 mm high GN 1/6 pan.
- It heats up the pan quickly: simply place it on the griddle and allow the heat to melt the butter inside.
- Easy to use, you just need to gently turn the wheel and the butter will spread quickly and comfortably.
- The wheel is removable for easy and thorough cleaning.
- Its ergonomic design makes it easy and efficient to use, saving time in the kitchen.

Ablandacarnes

INOX 18/10 Dishwasher



Dispone de un lado liso y otro rugoso
It has a smooth side and a rough side.

Mango ergonómico y antideslizante
Ergonomic non-slip handle

Maza ablandacarne

Attendrisseur de viande · Fleischhammer
Meat mallet · Maço para amciar carne

Ref	€	cm	h(cm)	U.Venta
61251	25,80	27x8	11,0	1

Martillo ablandacarne

Marteau attendrisseur de viande · Fleischklopper Hammer
Meat hammer tenderizer · Martelo ablandador de carne

Ref	€	cm	U.Venta
60431	17,40	7x24	1



INOX

Ablandacarne Inox

Attendrisseur à viande en Inox · Fleischklopper, Edelstahl
St. steel meat tenderizer · Ablandacarne Inóx

Ref	€	cm	U.Venta
60432	38,70	12x2	1



Ablandacarne Black

Attendrisseur de viande · Fleischhammer
Meat mallet · Maço para amciar carne

Ref	€	Cuchilla (cm)	U.Venta
61250	9,10	6x3	1

Morteros

GRANITO
Granite

BPA free

New



- Robusto, elegante y funcional. Sabor auténtico.
- Fabricado en granito macizo, material natural de alta densidad.
- Máxima durabilidad, resistencia al desgaste y una gran estabilidad durante el uso, incluso en las preparaciones más exigentes.
- Superficie ligeramente rugosa: permite triturar y moler ingredientes con eficacia, extrayendo aceites esenciales y sabores de forma óptima.
- Incluye mano también de granito, diseñada para un agarre cómodo y eficiente.
- Su diseño atemporal combina a la perfección con todo tipo de cocinas, tanto domésticas como profesionales.

- Robust, elegant and functional. Authentic flavour.
- Made from solid granite, a high-density natural material.
- Maximum durability, wear resistance and great stability during use, even when preparing the most demanding dishes.
- Slightly rough surface: allows ingredients to be crushed and ground effectively, extracting essential oils and flavours optimally.
- Includes granite handle, designed for a comfortable and efficient grip.
- Its timeless design blends perfectly with all types of kitchens, both domestic and professional.



Mortero Molcajete

Mortier · Mörser
Mortar · Argamassa

Ref	€	Ø (cm)	h(cm)	ml	U.Venta
60515	30,50	20	9	850	1

Mortero con mano de granito

Mortier et pilon en granit · Mörser und Stößel aus Granit
Granite mortar and pestles · Argamassa e pilão do granito

	Ref	€	Ø (cm)	h(cm)	ml	U.Venta
A	60512	26,50	12	8	250	1
B	60514	30,90	14	10	375	1
	60516	32,20	16	12	600	1
C	60517	25,70	10,5	7,5	225	1
D	60518	26,10	12	12,0	365	1

Mortero White

Mortier · Mörser
Mortar · Almofariz

Ref	€	Ø (cm)	U.Venta
60403	165,10	18	1

A

Interior no poroso, permite extraer los aceites naturales de las hierbas y especias
Interior not porous allowing extracting natural oils from herbs and spices

Pesado y bien balanceado
Heavy and well balanced

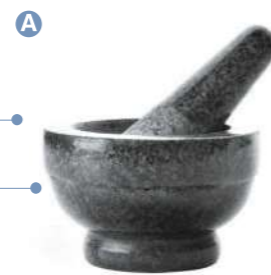

B



C



D



PE

Polyethylene BPA free

Mano mortero

Poussoir à mortier · Stößel
Pestle · Pilão p/almofariz

Ref	€	Ø (cm)	Largo (cm)	U.Venta
60401	40,30	Ø4,8	25	1



Exprimidores manuales

INOX
18/10

Dishwasher



Dishwasher

Exprimidor manual inox

Presse-fruits manuel · Manuelle fruchtpresse
Manual squeezer · Espremedor de sumos

Ref	€	cm	h(cm)	U.Venta
63914	55,20	15x19	39,0	1



Exprimidor Inox

Presse citron manuel · Manuelle zitronenpresse
Manual reamer · Espremedor manual

Ref	€	Ø (cm)	L	U.Venta
62952	18,10	10	0,15	6
62912	21,20	12	0,20	6



Exprimidor manual Flor

Presse citron manuel · Manuelle zitronenpresse
Manual reamer · Espremedor manual

Ref	€	Ø (cm)	h(cm)	U.Venta
63912	13,00	4,5	16	1



Dishwasher

ABS
Plastic

BPA free

Exprimidor manual con jarra medidora

Presse citron manuel · Manuelle zitronenpresse
Manual reamer · Espremedor manual

Ref	€	cm	h(cm)	L	U.Venta
67134	7,50	18,5 x 11	15	0,5	1



PP
Polypropylene

PMMA
Plastic

BPA free

Exprimidor manual mini

Presse citron manuel · Manuelle zitronenpresse
Manual reamer · Espremedor manual

Ref	€	cm	h(cm)	ml	U.Venta
68181	6,60	10x9,5	8,5	70	1



Exprimidor manual

Presse citron manuel · Manuelle zitronenpresse
Manual reamer · Espremedor manual

	Ref	€	Largo (cm)	U.Venta
A	63915	11,40	22	1
B	68182	26,50	22	1



Exprimidor limón

Presse-citron · Zitruspresse
Lemón squeezer · Espremedor de limão

Ref	€	cm	U.Venta
62946	12,00	12 x 2,5 x 5,5	1



Contenedor de alimentos

6
Cont.



450
ml (x6)

- Contenedor para condimentos con cuerpo de acero inoxidable.
- 6 contenedores extraíbles de 450 ml de capacidad, fabricados en polipropileno. Apilables. Libres de BPA.
- La tapa transparente protege y mantiene los alimentos frescos y permite ver el contenido.
- Ideal para organizar todo tipo de especias, condimentos, ingredientes para cócteles y mucho más.
- Higiénico, fácil de limpiar. Contenedores aptos para lavavajillas.

- Récipient pour condiments avec corps en acier inoxydable.
- 6 récipients amovibles d'une capacité de 450 ml, fabriqués en polypropylène. Empilables. Sans BPA.
- Le couvercle transparent protège et conserve les aliments frais et permet de voir le contenu.
- Idéal pour organiser toutes sortes d'épices, de condiments, d'ingrédients pour cocktails et bien plus encore.
- Hygiénique, facile à nettoyer. Récipients adaptés au lave-vaisselle.

- Condiment container with stainless steel body.
- 6 removable containers with a capacity of 450 ml, made of polypropylene. Stackable. BPA free.
- The transparent lid protects and keeps food fresh and allows you to see the contents.
- Ideal for organising all kinds of spices, seasonings, cocktail ingredients and much more.
- Hygienic, easy to clean. Dishwasher safe.

Ideal para especias, condimentos y decoración para cócteles

Ideal for spices, seasonings and cocktail decoration



New

INOX PP ABS BPA free
Polypropylene Plastic

Contenedor de alimentos Inox

Boîte à condiments · Gewürzkasten
Condiments holder · Caixa condimentos

Ref	€	cm	h(cm)	ml	Compartimentos	U.Venta
61146	39,20	45x15	10,0	450	6	1

Preparación
Food processing



PE ASA BPA free
Polyethylene Acrylic

Contenedor de alimentos

Boîte à condiments · Gewürzkasten
Condiments holder · Caixa condimentos

Ref	€	cm	ml	Compartimentos	U.Venta
61133	28,50	50x16x9	1000	3	1
61134	28,50	50x16x9	750	4	1
61135	28,50	50x16x9	600	5	1
61136	28,50	50x16x9	450	6	1



Máquina laminadora de pasta

INOX Healthy Cooking



Regulador de grosor de pasta (3,4 mm - 0,93 mm)
Pasta thickness regulator (3,4 mm - 0,93 mm)



Medidor de pasta inox

Mesureur pour pâtes en Inox · Spaghetti-Mass Rostfrei
St steel pasta measurer · Medidor para macarrao en Inóx

Ref	€	cm	U.Venta
A 62942	3,40	18	1
B 62943	4,70	11x9	1



2
Columns



3
Columns

Máquina laminadora de pasta

Machine Lamineuse à pâte · Pastamaschine
Pasta Machine Slicer · Maquina de Pasta

Ref	€	Espesor corte	mm	U.Venta
A 60390	46,60	0,2 - 3 mm	145	1
B 60391	86,10	0,2 - 3 mm	260	1

Accesorios para ravioli

Accessoire pour raviolis · Zubehör für Ravioli
Ravioli maker · Acessório para ravióis

Ref	€	Medidas ravioli	U.Venta
A 60497	22,40	45x45 mm	1
B 60498	22,40	30x30 mm	1

Embutidora

INOX
18/10

Ø38 mm Ø32 mm Ø22 mm Ø16 mm



Incluye boquillas
Includes nozzles



- Fabricada en acero inoxidable 18/10 de gran calidad.
- Rápida y eficaz: diseñada para elaborar diferentes tipos de embutidos como chorizos, salchichas, butifarras, etc.
- Gran capacidad: ideal para carnicerías, restaurantes y cocinas industriales.
- Doble velocidad (lenta/rápida) gracias a un mecanismo de dos marchas accionado por rodamiento.
- Incluye 4 boquillas de llenado de acero inoxidable: Ø38 mm, Ø32 mm, Ø22 mm y Ø16 mm.
- Tuerca de unión de fácil manejo que permite cambiar rápidamente las boquillas de llenado.
- La tolva se puede inclinar a 90 grados para llenar, limpiar y desmontar.

- Fabriqué en acier inoxydable 18/10 de haute qualité.
- Rapide et efficace: conçu pour faire différents types de saucisses.
- Grande capacité: idéal pour les bouchers, les restaurants et les cuisines industrielles.
- Double vitesse (lent / rapide) grâce à un mécanisme à deux vitesses entraîné par le roulement.
- Comprend 4 buses de remplissage en acier inoxydable: Ø38 mm, Ø32 mm, Ø22 mm et Ø16 mm.
- Écrou de liaison de manipulation facile qui vous permet de changer rapidement les buses de remplissage.
- La trémie peut être inclinée à 90 degrés pour remplir, nettoyer et se désassembler.

- Made of stainless steel 18/10 of high quality.
- Fast and effective: designed to make different types of sausages.
- Great capacity: ideal for butchers, restaurants and industrial kitchens.
- Double speed (slow/fast) thanks to a two-speed mechanism driven by bearing.
- Includes 4 stainless steel filling nozzles: Ø38 mm, Ø32 mm, Ø22 mm and Ø16 mm.
- Easy handling binding nut that allows you to quickly change filling nozzles.
- The hopper can be tilted at 90 degrees to fill, clean and disassemble.

Máquina embutidora

Poussoir manuel · Manuelle Wurstfüller
Manual stuffer · Máquina para encher salsichas manual

Ref	€	h(cm)	Cilindro (cm)	L	U.Venta
60253	286,30	52,3	Ø14 x 20	3	1
60255	328,20	64,7	Ø14 x 32	5	1
60257	378,50	78,0	Ø14 x 46	7	1
60251	435,90	60,5	Ø22 x 27	10	1

Clipadora

INOX

- Fabricada en acero inoxidable de máxima calidad.
- Diseñada para grapar embutidos, mallas de fruta, bolsas, etc. con el mínimo esfuerzo.
- Accionamiento manual fácil y muy cómodo.
- Sistema de apoyo de zamak macizo que garantiza una estabilidad máxima.
- Capacidad de grapas: 200 unidades (ref: 61201 - no incluidas).
- Fácil de limpiar.

- Fabriqué en acier inoxydable de qualité maximale.
- Conçu pour pomper des saucisses, des mailles de fruits, des sacs, etc. Avec l'effort minimum.
- Drive manuel facile et très confortable.
- Système de soutien Zamak solide qui garantit un stabilide maximal.
- Capacité temporaire: 200 unités (Réf: 61201 - Non incluse).
- Facile à nettoyer.

- Manufactured in maximum quality stainless steel.
- Designed to pump sausages, fruit meshes, bags, etc. With the minimum effort.
- Easy and very comfortable manual drive.
- Solid Zamak Support System that guarantees a maximum stabilid.
- Temporary capacity: 200 units (Ref: 61201 - Not included).
- Easy to clean.

GRAPAS · STAPLES
Ref: 61201
No incluidas · Not included

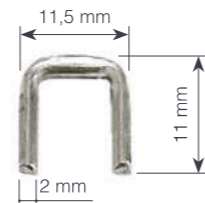

Regulación de presión
Pressure adjustment

Clipadora

Clippeuse d'aliments · Lebensmittelzacker
Food clipping machine · Agrafadora para alimentos

Ref	€	cm	h(cm)	U.Venta
61200	307,70	37x15	58,5	1
61201	22,70	4,6 - 6	-	1



3 in 1
Centrifugadora
Eessoreuse
Spinner
Escurreidor
Passoire
Colander
Ensaladera
Saladier
Salad bowl

Centrifugadoras



- Diseñada para escurrir ensaladas y verduras.
- Gracias a su gran velocidad de centrifugado escurren la lechuga y las verduras en segundos.
- Fácil manejo gracias al pomo giratorio ergonómico.
- Versátil: está compuesta por 3 piezas: tapa, rejilla y bol, perfecto para servir la ensalada en el mismo recipiente.
- Base antideslizante y 100% estable.
- Fácil limpieza: apta para el lavavajillas.
- 100% libre de BPA.

- Conçu pour drainer les salades et les légumes.
- Grâce à sa grande vitesse centrifugée, la laitue et les légumes s'écoulent en quelques secondes.
- Manipulation facile grâce au bouton rotatif ergonomique.
- Polyvyle: Il est composé de 3 pièces: couvercle, grille et bol, parfait pour servir la salade dans le même récipient.
- Base non glissante et 100% stable.
- Nettoyage facile: adapté au lave-vaisselle.
- 100% sans BPA.

- Designed to drain salads and vegetables.
- Thanks to its great centrifuged speed, lettuce and vegetables drain in seconds.
- Easy handling thanks to the ergonomic rotating knob.
- Versatile: It is composed of 3 pieces: lid, grid and bowl, perfect to serve the salad in the same container.
- Non-slip base and 100% stable.
- Easy cleaning: suitable for dishwasher.
- 100% BPA free.

Para uso profesional, sencillo y eficaz

For professional use, simple and efficient



PP
Polypropylene



Centrifugadora Profesional

Essereuse à salade · Salatschleuder
Salad spinner drier · Centrifugadora professional

Ref	€	Ø (cm)	h(cm)	L	U.Venta
61420	207,90	32	33	12,0	1
61425	231,80	42	40	25,0	1



Centrifugadora Klein

Essoreuse · Salatschleuder
Spinner · Centrifugadora

Ref	€	Ø (cm)	h (cm)	L	U.Venta
61422	19,60	20,5	19,0	2,6	1



PP SAN
Polypropylene Plastic

Centrifugadora White

Essoreuse · Salatschleuder
Spinner · Centrifugadora

Ref	€	Ø (cm)	h(cm)	L	U.Venta
61403	30,40	26	20,0	5,00	1



Aguja de mechar

INOX
18/10
Dishwasher

Puntiaguda y alargada
Pointed and elongated shape

Doble superficie dentada
para una perfecta sujeción
Double-toothed surface for optimal grip



- Su forma puntiaguda y alargada, permite abrir orificios fácilmente en la carne o pescado e insertar tiras de beicon, verduras, frutas, quesos o especias.
- Sistema de amarre con doble superficie dentada para una perfecta sujeción.
- Consigue carnes más sabrosas y pescados más jugosos.
- Apta para el lavavajillas.

- Sa forme pointue et allongée, vous permet d'ouvrir facilement des trous dans la viande ou le poisson et d'insérer des bandes de bacon, des légumes, des fruits, des fromages ou des épices.
- Système d'amarrage avec double dents pour un support parfait.
- Obtenez des viandes plus savoureuses et plus de poissons juteux.
- Lavable au lave-vaisselle.

- Its pointed and elongated shape, allows you to open holes easily in meat or fish and insert bacon strips, vegetables, fruits, cheeses or spices.
- Mooring system with double teeth for perfect support.
- Get tastier meats and more juicy fish.
- Dishwasher safe.

Carnes y pescados más jugosos · Juicer meats and fish



Aguja de Mechar

Aiguille à larder · Spicknadel
Stuffing needle · Agulha de mechar

Ref	€	Largo (cm)	U.Venta
61362	4,90	19	6

Jeringas y pipetas para cocina

ASA
Acrylic
Dishwasher
BPA free

Inyecta salsas o especias. Extrae la salsa para reducirla en la sartén

Inject sauces or spices. Extract the sauce to reduce it in the pan



INOX

Pipeta para salsa

Poire à jus · Sossenspritze
Sauce syringe · Pipeta para molho

Ref	€	Largo (cm)	ml	U.Venta
A 61408	18,10	30	40	1
B 61416	13,20	30	40	1

Jeringa para cocina

Seringue de cuisine · Spritze Küche
Kitchen syringe · Seringa para cozinha

Ref	€	Largo (cm)	ml	Unidad	U.Venta
61418	6,20	21,5	30	ml-oz-tsp-Tbsp	6



Botellas biberon

PE LDPE
Polyethylene Polyethylene
BPA free

- Ideales para salsas, cremas, aceites, aliños, vinagretas y todo tipo de condimentos líquidos.
- Dibuja, adorna y personaliza con estilo tus platos.

- Idéal pour les sauces, les crèmes, les huiles, les assaisonnements, les vinaigrettes et tout type de condiments liquides.
- Il dessine, décore et personnalise les plats.

- Ideal for sauces, creams, oils, dressings, vinaigrettes and all kinds of liquid condiments.
- Draw, decorate and personalize your dishes with style.



Polyethylene (PE)

Polyethylene (PELD)
Polyethylene Low Density



Botella biberón

Bouteille biberon · Dosierflasche
Squeeze bottle · Garrafa

Ref	€	Ø (cm)	L	U.Venta
61912	1,50	4x10	0,12	12
61925	1,60	5x19	0,25	12
A 61940	1,80	5,5x21,5	0,40	12
61970	2,00	7x26	0,70	12
61925R	1,60	5x19	0,25	12
B 61940R	1,80	5,5x21,5	0,40	12
61970R	2,00	7x26	0,70	12
61925A	1,60	5x19	0,25	12
C 61940A	1,80	5,5x21,5	0,40	12
61970A	2,00	7x26	0,70	12

Polyethylene (PE)

Polyethylene (PELD)
Polyethylene Low Density

Botella biberón Tri

Bouteille biberon · Dosierflasche
Squeeze bottle · Garrafa

Ref	€	Ø (cm)	h (cm)	L	U.Venta
61974	4,10	7	20	0,45	6
61977	4,40	7	26	0,70	6
61981	4,60	8	26	1,00	6

New

PE
Polyethylene
BPA free

Botella biberon Push

Bouteille biberon · Dosierflasche
Squeeze bottle · Garrafa

Ref	€	Ø (cm)	L	U.Venta
61978	4,60	6x20	0,50	1
61979	4,70	7x20	0,60	1
61980	4,90	7x26	0,70	1

SI
Silicone

Botella decoración

Biberon à décorer · Dekorierflasche
Decorating pen · Garrafa decoração

Ref	€	Ø (cm)	L	U.Venta
64457	9,80	5,5x16	0,14	1



Dosificadores

INOX 18/10
Dishwasher

- Ideal para rellenar o decorar platos con salsas y cremas calientes y frías.
- Sistema de palanca para un caudal ajustable; práctico y preciso.
- Sistema antigoteo y antisalpicaduras.
- Mango con diseño ergonómico que permite el manejo con una sola mano.
- Fácil desmontaje para una sencilla limpieza. Apto para el lavavajillas.

- Idéal pour garnir ou décorer les plats avec des sauces et des crèmes chaudes ou froides.
- Système à levier pour un débit réglable, pratique et précis.
- Système anti-goutte et anti-éclaboussures.
- Poignée ergonomique permettant une utilisation d'une seule main.
- Démontage facile pour un nettoyage aisé. Lavable au lave-vaisselle.

- Perfect for filling or decorating dishes with hot or cold sauces and cream.
- Its lever system for controlling the flow is practical and precise.
- Anti-drip and anti-splash system.
- The ergonomic handle means it can be used with just one hand.
- It's easy to disassemble for easy cleaning and it's dishwasher safe.



3
Boquillas
Nozzles

Sistema de gatillo para un caudal ajustable
Trigger system for an adjustable flow



Sistema de gatillo para un caudal ajustable
Trigger system for an adjustable flow



Fabricado en acero inoxidable
Made of stainless steel

Incluye soporteteo
Includes support

Incluye soporte y un platillo antigoteo
Includes support and a drip dish

Dosificador Inox
Entonnoir à décor · Dosierer
Portionner · Dosificador

Ref	€	Ø (cm)	h(cm)	L	U.Venta
67150	63,30	19	27	2,0	1

Embudo Dosificador
Decor entonnoir · Dosier dosiertrichter
Portionner funnel · Dosificador funil

Ref	€	Ø (cm)	h(cm)	L	U.Venta
67151	22,10	13,5	26	1,25	1

3
Boquillas
Nozzles

Sistema de gatillo para un caudal ajustable
Trigger system for an adjustable flow



Marcas de medición (ml - cup)
Measuring marks (ml - cup)

Sistema de gatillo para un caudal ajustable
Trigger system for an adjustable flow



SI PE
Silicone Polyethylene BPA free

Dosificador Red
Entonnoir à décor · Dosierer
Portionner · Dosificador

Ref	€	cm	h(cm)	L	U.Venta
67026	12,10	16x11	18	1,0	1

Dosificador Ration
Entonnoir à décor · Dosierer
Portionner · Dosificador

Ref	€	L	U.Venta
67000	91,00	2,00	1

Sifones

INOX 18/10 INOX AL
Aluminium Dishwasher

- Robusto y duradero.
- Marcaje de llenado grabado en el exterior del cuerpo.
- Versátil: Diseñado para espumas frías y espumas calientes.
- Incluye 3 boquillas de acero inoxidable con formas decorativas.
- Funciona con cargas de gas (N2O).
- Cepillo limpiador para facilitar la limpieza.

- Robuste et durable.
- Marquage de remplissage gravé à l'extérieur du corps.
- Versatile : conçu pour des préparations froides et chaudes.
- Inclut 3 douilles en acier inoxydable avec des formes décoratives.
- Fonctionne avec des cartouches de gaz (N2O).
- Brosse pour faciliter le nettoyage.

- Robust and durable.
- Embossed filling marks on the outside.
- Versatile: designed for whipping up hot or cold foams.
- Includes 3 stainless steel nozzles with decorative shapes.
- Charged with gas cartridges (N2O).
- Professional syphon for culinary use.
- Cleaning brush for easy cleaning.

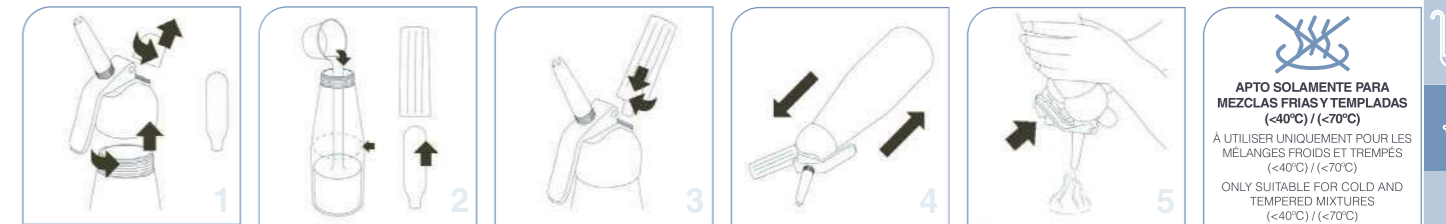

APTO SOLAMENTE PARA MEZCLAS FRÍAS Y TEMPLADAS (<40°C) / (<-70°C)
À UTILISER UNIQUEMENT POUR LES MÉLANGES FROIDS ET TREPÉS (<-40°C) / (<-70°C)
ONLY SUITABLE FOR COLD AND TEMPERED MIXTURES (<40°C) / (<-70°C)

Inox 18/10

Inox 18/10

Sifón Epicure

Siphon à crème · Sahnebereite
Cream whipper · Sifão creme

Ref	€	Ø (cm)	L	U.Venta
68300	111,00	9,0	0,50	1
68301	126,00	9,0	1,00	1

Temperatura de uso · Use temperature
min = +5°C / max = +70°C

Aluminium

Inox

Sifón Mix

Siphon à crème · Sahnebereite
Cream whipper · Sifão creme

Ref	€	Ø (cm)	L	U.Venta
68404	85,00	7,8x25	0,50	1
68405	97,70	9,3x32,5	1,00	1

Temperatura de uso · Use temperature
min = +5°C / max = +40°C

Aluminium

Aluminium

Sifón black

Siphon à creme · Sahnebereiter
Cream whipper · Sifão creme

Ref	€	Ø (cm)	L	U.Venta
68604	52,10	7,8x27,3	0,50	1
68605	57,40	9,3x32,5	1,00	1

Temperatura de uso · Use temperature
min = +5°C / max = +40°C

EXCLUSIVAMENTE PARA USO ALIMENTICIO
EXCLUSIVELY FOR FOOD USE

PBT plastic

Aluminium

Sifón White

Siphon à creme · Sahnebereiter
Cream whipper · Sifão creme

Ref	€	Ø (cm)	L	U.Venta
68502	41,70	9x27	0,25	1
68500	49,40	9x31	0,50	1
68501	55,10	11x36	1,00	1

Temperatura de uso · Use temperature
min = +5°C / max = +40°C

Cargas para sifón N2O

Charges de siphon N2O · N2O-Flaschen für Siphon
Charges for N2O siphon · Cargas para sifão N2O

Ref	€	Botellas	Peso (g)	U.Venta
68402	8,50	10	8	1
68403	19,90	24	8	1



NUNCA ponga los sifones al baño maría, puede producirse una explosión con graves consecuencias.
NE JAMAIS mettre les siphons au bain marie car une explosion pourrait avoir lieu et provoquer de graves conséquences.
NEVER put siphons in a water bath, as this may cause an explosion with serious consequences.



Ahumadores

AL
Aluminium Dishwasher

- Técnica popular de la cocina creativa; otorga a los platos aromas especiales y personalizados.
- Perfecto para ahumar todo tipo de alimentos (carnes, pescados, quesos...).
- La construcción y su diseño facilitan la limpieza y el mantenimiento.
- Ideal para presentar y terminar platos delante del cliente.
- Incluye un set de filtros de recambio.
- Fácil de transportar gracias a su forma y tamaño.
- Pilas no incluidas.
- * Compatible con nuestras campanas de ahumado y la tapa.

- Technique populaire de la cuisine créative; qui confère aux plats des arômes spéciaux et personnalisés.
- Parfait pour fumer tout type d'aliments (viandes, poissons, fromages...).
- La fabrication et la conception de chacune de ses parties facilite son nettoyage et son entretien.
- Idéal pour présenter et apporter la touche finale à des plats devant le client.
- Inclut un set de filtres de rechange.
- Facile à transporter grâce à sa forme et sa taille.
- Piles non incluses.
- * Compatible avec nos cloches de fumage et à couvercle.

- A popular creative cooking technique which gives dishes special and personalised aromas.
- Perfect for smoking all kinds of foods (meat, fish, cheeses...).
- The way is designed and constructed makes it easy to clean and maintain.
- Ideal for presenting and finishing dishes in front of the customer.
- Includes a set of replacement filters.
- Easy to transport thanks to its shape and size.
- Batteries not included.
- * Compatible with our smoking cloches and the lid.



- Permite ahumar dos platos a la vez, ahorrando tiempo.
- Incluye 2 mangueras de goma de 40 cm, 2 boquillas y un conector de conexión de mangueras.

- Il permet de fumer deux plats à la fois, économisant ainsi du temps.
- Il comprend deux tuyaux en caoutchouc de 40 cm, deux embouts et un raccord de tuyaux.

- Two dishes can be smoked at once to save time.
- Two 40 cm rubber hoses, two nozzles and a hose connector included.



Manguera doble para ahumador

Double tuyau pour fumoir · Doppelschlauch für Räucherapparat
Double hoses for smoker · Mangueira dupla para defumador

Ref	€	Largo (cm)	U.Venta
69521	8,20	40	1

Campanas para ahumar

VIDRIO SI
Glass Silicone

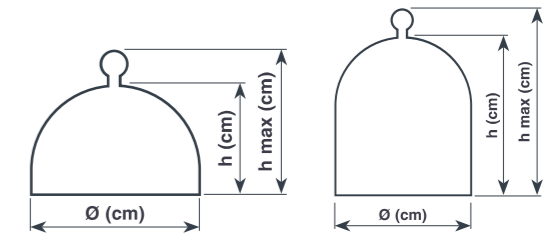

- Fabricada en cristal borosilicato de gran calidad. Es resistente a golpes, altas y bajas temperaturas.
- Permite la entrada de humo, vapor y aromas para ahumar o aromatizar alimentos sin tener que levantar la tapa.
- Cuenta con una válvula de inyección con autocierre de silicona (max. 200°C).
- Apta para microondas, horno y congelador.
- Complemento ideal para los ahumadores de alimentos Lacor.

- Fabriqué en verre borosilicaté de haute qualité. Résistant aux chocs, aux températures élevées et basses.
- Permet la circulation de la fumée, de la vapeur et des arômes pour fumer ou aromatiser les aliments sans avoir à soulever le couvercle.
- Elle est équipée d'une valve d'injection à fermeture automatique en silicone (max. 200 °C).
- Convient pour le micro-ondes, le four et le congélateur.
- Complément idéal pour les fumoirs alimentaires Lacor.

- Made from high-quality borosilicate glass. It is resistant to shocks and high and low temperatures.
- Allows smoke, steam and aromas to enter so you can smoke or flavour food without having to lift the lid.
- It has a self-closing silicone injection valve (max. 200°C).
- Suitable for microwave, oven and freezer use.
- The ideal accessory for Lacor food smokers.



Campana ahumador

Cloche à fumer · Räucherglocke
Smoker Hood · · Campânula defumadora

	Ref	€	Ø (cm)	h(cm)	h max (cm)	U.Venta
A	61813	13,00	12,5	7,5	11,0	1
B	61815	21,30	16,0	12,0	15,0	1
C	61816	23,60	20,0	12,0	15,0	1
D	61817	40,30	25,0	14,0	17,0	1
E	61811	27,30	18,5	22,0	25,0	1
F	61812	32,50	12,5	26,5	30,0	1



Incluyen bolsa de serrín (Olivo - 100 g)
Wood Chips bag included (Olive - 100 g)

Ahumador de alimentos

Fumoir pour aliments · Apparat zum Räuchern von Lebensmitteln
Food smoker · Defumador de alimentos

	Ref	€	U.Venta
A	69221	44,90	1
B	69321	60,20	1

Serrín para ahumar

A



100 g

- Serrín especial de madera (99'9 % de pureza).
- Produce un humo denso y de alta calidad.
- Aporta un sabor muy suave aromatizado a los alimentos, gracias a una combustión lenta a baja temperatura.
- Cumple todas las normas y reglamentaciones existentes para el empleo con los alimentos.
- Compatible con el ahumador de alimentos de Lacor (ref. 69221 y ref: 69321).
- OLIVO: aporta a los alimentos un sabor suave y aromático.
- NARANJO: aporta a los alimentos un sabor dulce, afrutado y el frescor de los cítricos.
- LIMONERO: aporta a los alimentos un toque cítrico y dulce muy suave.
- ALMENDRO: aporta a los alimentos un aroma suave, dulce y floral de la almendra.
- WHISKY: aporta a los alimentos un aroma de barril de roble empleado para el reposo del Whisky
- COGNAC: aporta a los alimentos un aroma de barril de roble empleado para el reposo del Cognac.

B



600 g

- Special Wood Serrin (Pureté de 99'9%).
- Il produit une fumée dense et de haute qualité.
- Il offre une saveur très douce aromatisée aux aliments, grâce à une combustion lente à basse température.
- Il répond à toutes les normes et réglementations existantes pour la nourriture avec de la nourriture.
- Compatible avec la nourriture de Lacor Ahumador (réf. 69221 et réf: 69321).
- OLIVE: apporte aux aliments un goût doux, fruité et la fraîcheur des agrumes.
- ORANGE: apporte aux aliments un arôme délicat, doux et floral d'amande.
- CITRONNIER: apporte aux aliments une touche d'agrumes douce et très délicate.
- AMANDIER: apporte aux aliments un arôme délicat, doux et floral d'amande.
- WHISKY: apporte aux aliments un arôme de fut de chêne utilisée pour le vieillissement du whisky.
- COGNAC: apporte aux aliments un arôme de fut de chêne utilisée pour le vieillissement du cognac.

- Special Wood Serrin (99'9 % purity).
- It produces a dense and high quality smoke.
- It provides a very soft flavor aromatized to food, thanks to slow combustion at low temperature.
- It meets all existing standards and regulations for food with food.
- Compatible with Lacor's food ahumador (Ref. 69221 and REF: 69321).
- OLIVE: provides food a smooth and aromatic flavour.
- ORANGE: provides food a sweet, fruity taste and citrusy freshness.
- LEMON: provides food a very soft sweet citrusy touch.
- ALMOND: provides food with a soft, sweet, floral aroma of almonds.
- WHISKY: aromatic sawdust from the oak barrel used for ageing the whisky.
- COGNAC: aromatic sawdust from the oak barrel used for ageing the cognac.

Natural 100% Quality

La mejor elección para ahumar todo tipo de alimentos

The best choice to smoke all kinds of food

Serrín para ahumar
Scire de bois · Räuchermehl
Wood chips · Serrín de madeira

Ref	€	g	U.Venta	
69550	6,80	100	1	Olivo · Olive
69551	6,80	100	1	Naranja · Orange
69552	6,80	100	1	Limonero · Lemon
69553	6,80	100	1	Almendro · Almond
69559	6,80	100	1	Whisky
69560	6,80	100	1	Cognac
69555	9,20	600	1	Olivo · Olive
69556	9,20	600	1	Naranja · Orange
69557	9,20	600	1	Limonero · Lemon
69558	9,20	600	1	Almendro · Almond
69567	8,70	500	1	Whisky
69568	8,70	500	1	Cognac

Medir y pesar

Measure and weigh

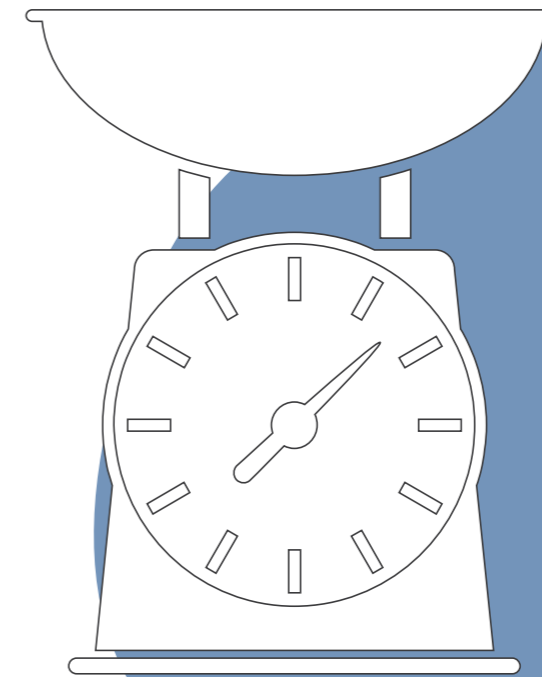

Preparación
Food processing

