

# Cable ladder for food industry

## HST KSE80-600 L=6000

Cable ladders KSE80 are suitable to use especially in food industry. Tube side profiles and special rungs enable cleaning and meet the food industry's hygiene requirements.



Product name	HST KSE80-600 L=6000		
SKU	1430106		
Material	Acid-proof steel		
Corrosivity category	C1-CX		
Color	Grey		
Sales unit	MTR		
Packing size	10 PCE / 60 MTR		
Dimensions (mm) Width   Height   Length	600	60	6000
Weight (kg/pce)	19,25		
GTIN	6438377102609		
Surface finish	Manufactured of stainless steel in accordance with standard EN 10088		

Dimension L (mm)	6000
Dimension A (mm)	600
Material thickness (mm)	1

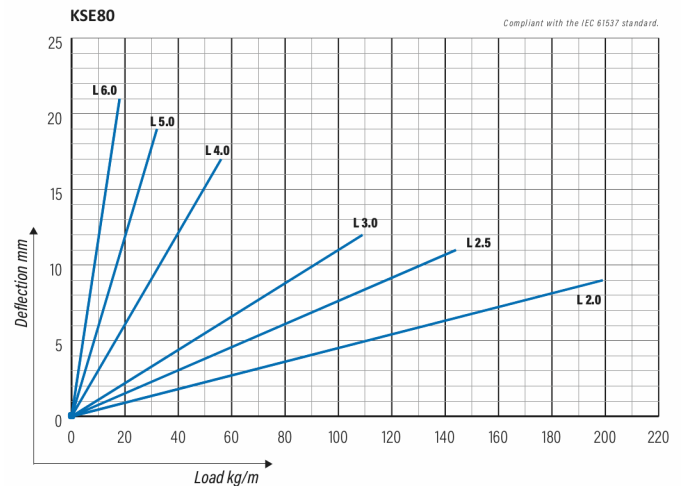
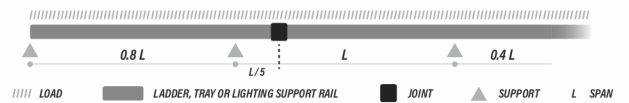
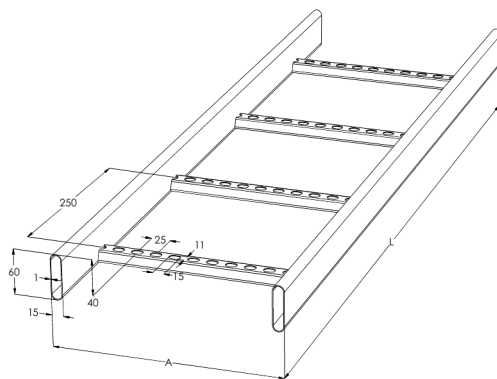

## Cable ladder for food industry

### HST KSE80-600 L=6000

