

MRM29

PAT. PEND.

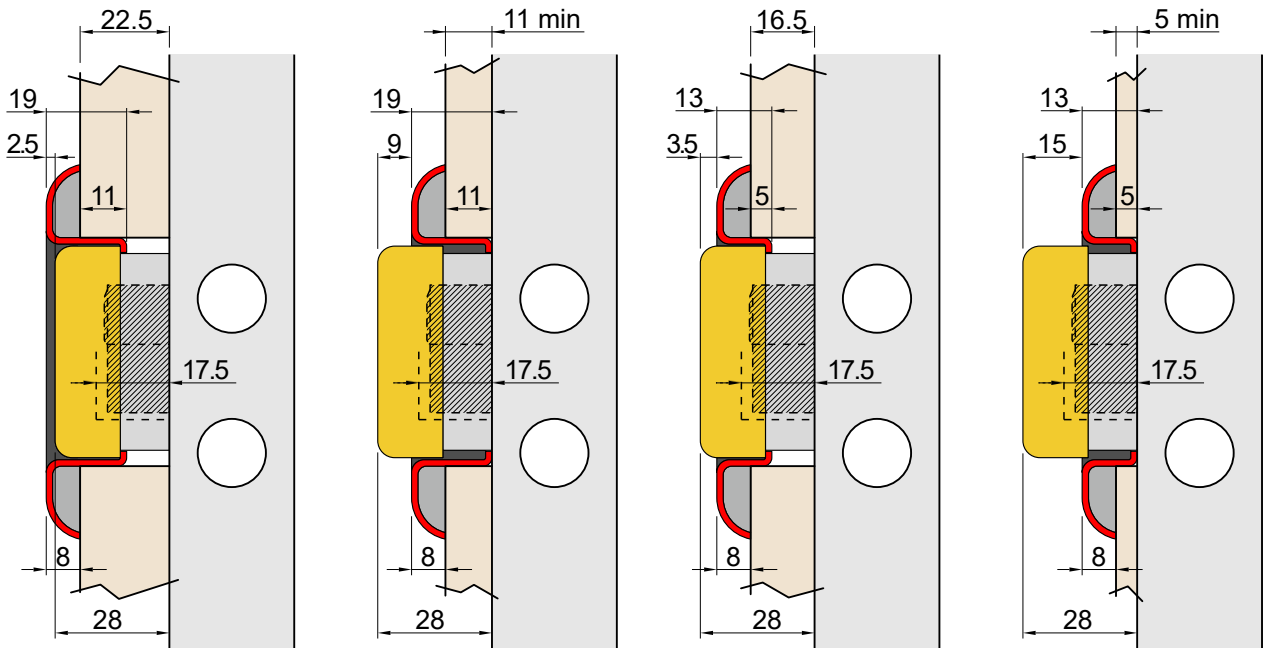

KMOP42
CHIAVE MAGNETICA
MAGNETIC KEY

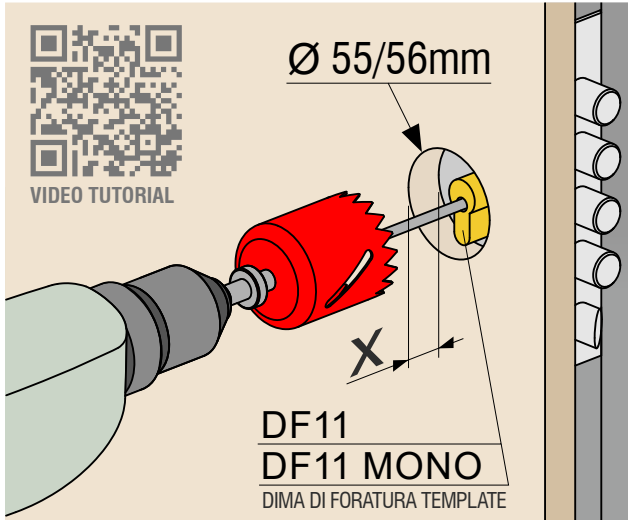
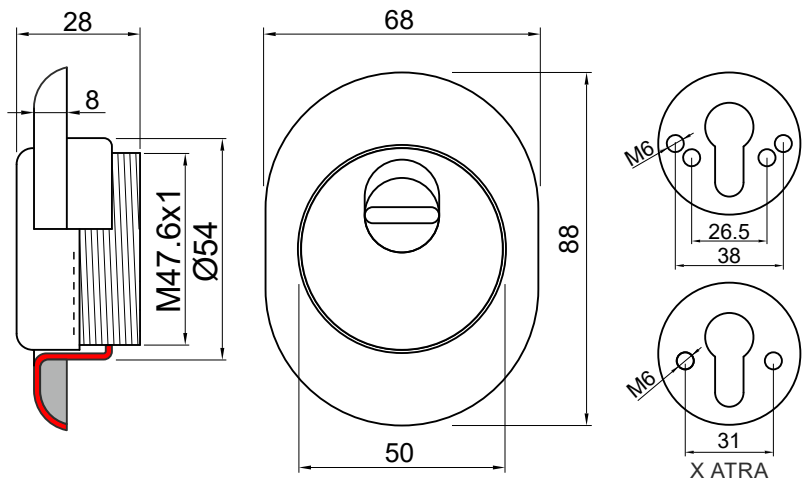

MRM29

PAT. PEND.



MAGNETIC KEY

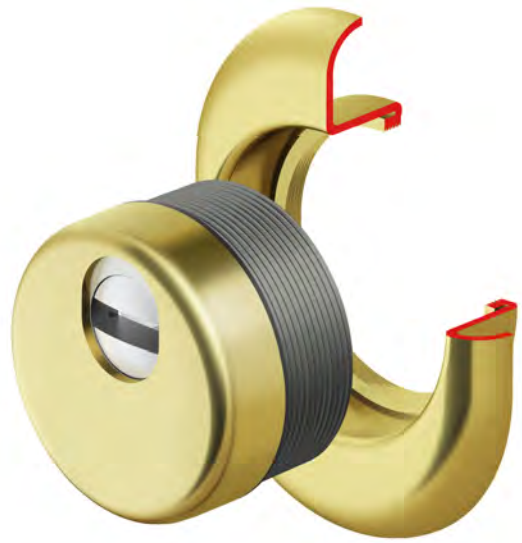

CONTROLLO ACCESSI
Access control

	MAGNETIC KEY CUSTOM PROFILE
	X OMEGA <i>VEDI CATALOGO</i> <i>See catalog</i>
	X MOTTURA 3D <i>VEDI CATALOGO</i> <i>See catalog</i>

VIDEO:

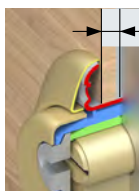
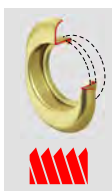
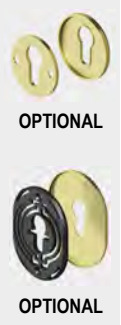
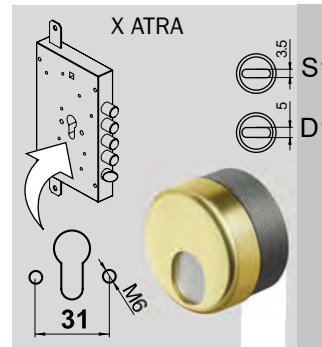
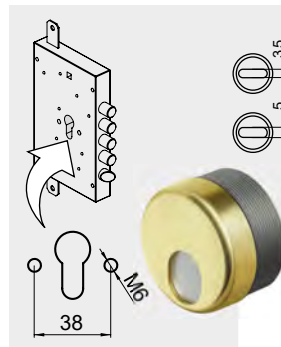
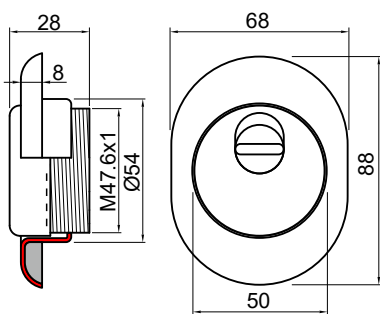

5 min

MRM29B 25 ..

MRM39B 25 ..

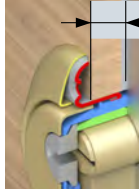
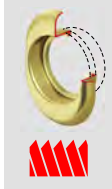

11 min

MRM29 25 ..

MRM39 25 ..

MRM29B 8 25
ESEMPIO CODICE

ESEMPIO DI CODICE PER VITI M8
EXAMPLE OF CODE FOR FIXING M8

- Cromo lucido
- Bright Chrome
- Cromo satinato
- Satin Chrome
- Bronzo
- Bronze
- PVD Ottone
- PVD Brass

FINITURE

ESEMPIO CODICE / EXAMPLE CODE:

XXXXX

H

D1/S1

C T 2

MR - 129 - MAG ROUND

FILETTATO



Ø50

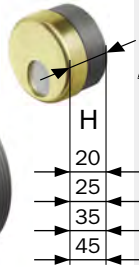

FINITURE FINISHES

X ATRA X OMEGA

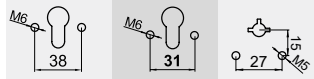

MR12920..	MR13920..	MR29820..
MR12925..	MR13925..	MR29825..
MR12935..	MR13935..	
MR12945..		

FINITURE FINISHES

- C Cromo lucido
Bright Chrome
- T Cromo satinato
Satin Chrome
- B Bronzo
Bronze
- 2 PVD Ottone
PVD Brass
- TT Ottone satinato
Satin Brass
- BS Bronzo satinato
Satin Bronze
- IT Inox satinato
Satin S.Steel

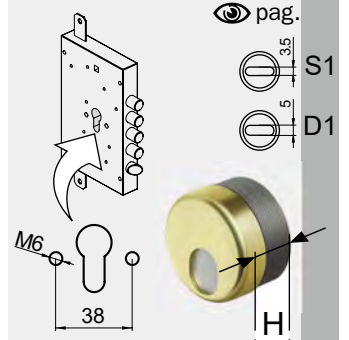

MR129	20	..	P
MR129	25	..	P
MR129	35	..	P
MR129	45	..	P



MRW129	20	..	P
MRW129	25	..	P
MRW129	35	..	P
MRW129	45	..	P



MRK129	20	..	P
MRK129	25	..	P
MRK129	35	..	P
MRK129	45	..	P

MRZ - 29 - MAG ROUND

Ø50

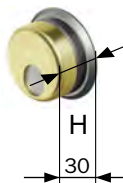

FINITURE FINISHES

X ATRA

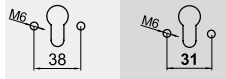

MRZ2930..	MRZ3930..
-----------	-----------

FINITURE FINISHES

- C Cromo lucido
Bright Chrome
- T Cromo satinato
Satin Chrome
- B Bronzo
Bronze
- 2 PVD Ottone
PVD Brass
- TT Ottone satinato
Satin Brass
- BS Bronzo satinato
Satin Bronze
- IT Inox satinato
Satin S.Steel

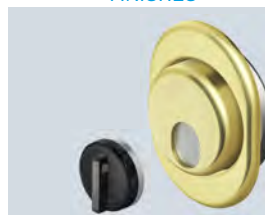
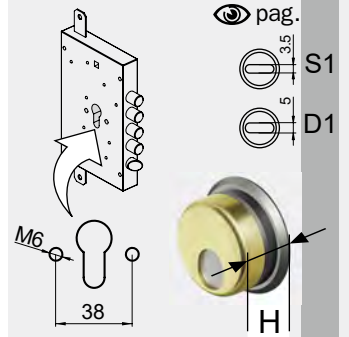

MRZ29	30	..	P
-------	----	----	---

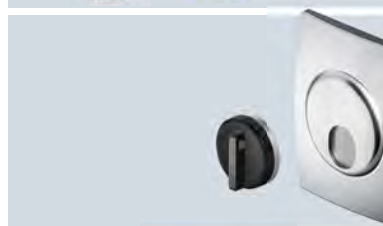

MRZW29	30	..	P
--------	----	----	---



MRZK29	30	..	P
--------	----	----	---

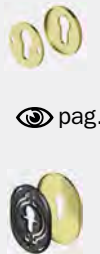
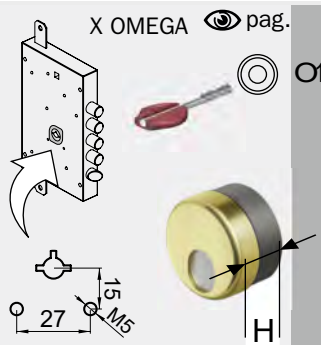
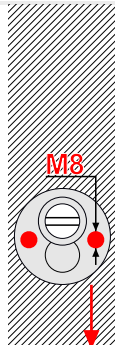
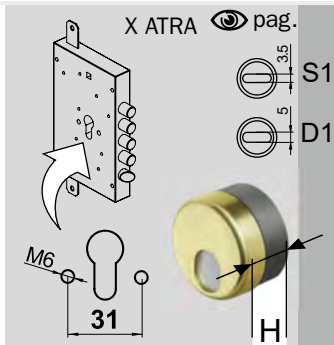

FINITURE FINISHES

- C Cromo lucido
Bright Chrome
- T Cromo satinato
Satin Chrome
- B Bronzo
Bronze
- 2 PVD Ottone
PVD Brass
- TT Ottone satinato
Satin Brass
- BS Bronzo satinato
Satin Bronze
- IT Inox satinato
Satin S.Steel

MR139 20
MR139 25
MR139 35

.. P
.. P
.. P

MR129 8 20..
ESEMPIO CODICE

ESEMPIO DI CODICE PER VITI M8
EXAMPLE OF CODE FOR FIXING M8

MR108 20 O1 P
MR108 25 O1 P

..
..
..
..

MRW139 20
MRW139 25
MRW139 35

.. P
.. P
.. P

MRW108 20 O1 P
MRW108 25 O1 P

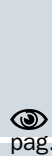

- C Cromo lucido
Bright Chrome
- T Cromo satinato
Satin Chrome
- B Bronzo
Bronze
- 2 PVD Ottone
PVD Brass
- IT Inox satinato
Satin S.Steel

MRK139 20
MRK139 25
MRK139 35

.. P
.. P
.. P

MRK108 20 O1 P
MRK108 25 O1 P

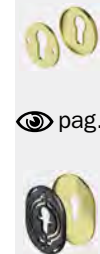
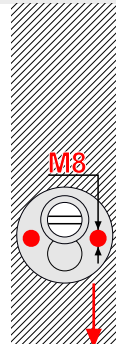
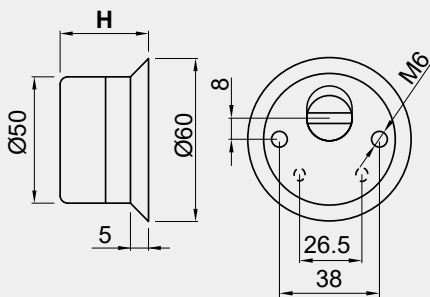
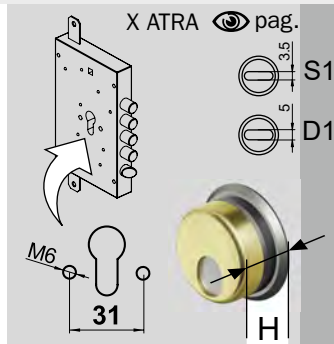

FINITURE FINISHES

- C Cromo lucido
Bright Chrome
- T Cromo satinato
Satin Chrome
- B Bronzo
Bronze
- 2 PVD Ottone
PVD Brass
- TT Ottone satinato
Satin Brass
- BS Bronzo satinato
Satin Bronze
- IT Inox satinato
Satin S.Steel

MRZ39 30

.. P

MRZ29 8 20
ESEMPIO CODICE

ESEMPIO DI CODICE PER VITI M8
EXAMPLE OF CODE FOR FIXING M8

MRZW39 30

.. P



- C Cromo lucido
Bright Chrome
- T Cromo satinato
Satin Chrome
- B Bronzo
Bronze
- 2 PVD Ottone
PVD Brass
- IT Inox satinato
Satin S.Steel

MRZK39 30

.. P