

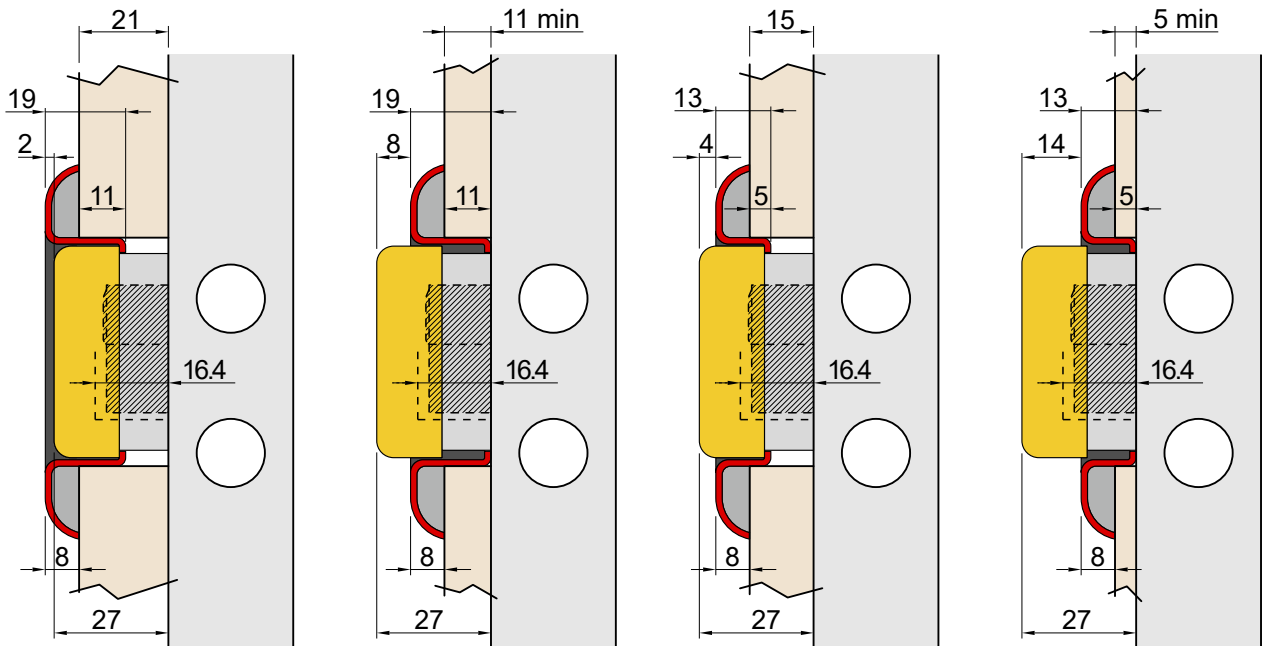

 **DIAMOND**

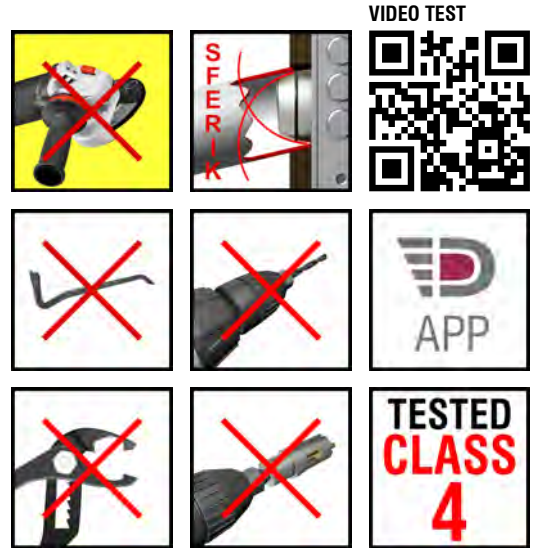

FLEX SYSTEM

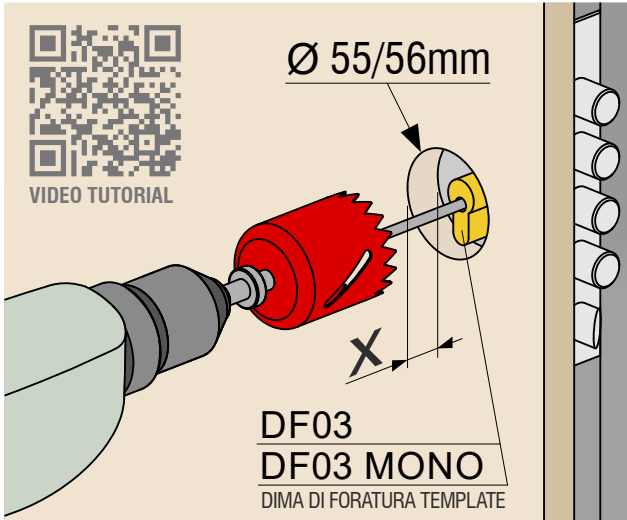

5 VOLTE PIU' RESISTENTE DELLE VITI TRADIZIONALI 12.9

VIDEO TEST

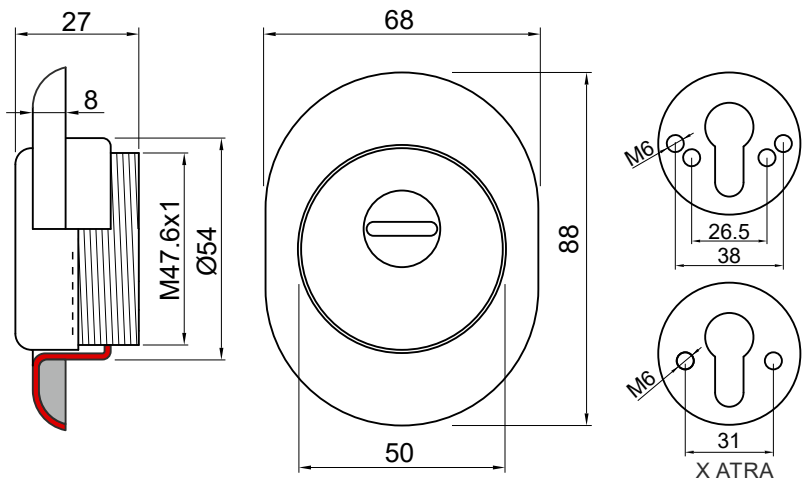



 **DIAMOND**

ROK SFERIK

PAT. PEND.



GRADO 4

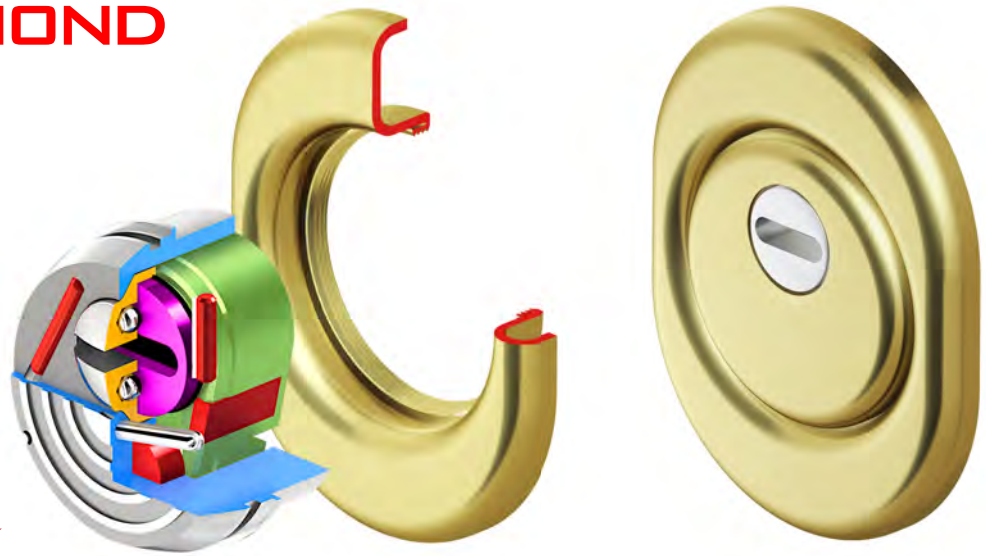

VIDEO:

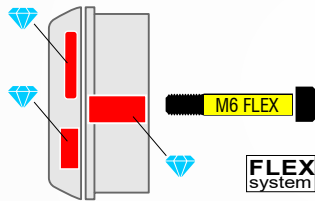

DIAMOND

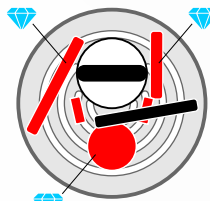

DIAMOND CARBIDE

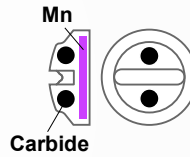

Mn CARBIDE

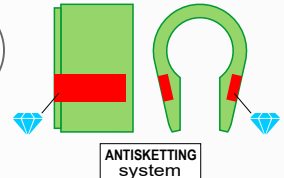



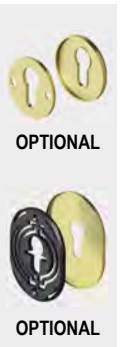
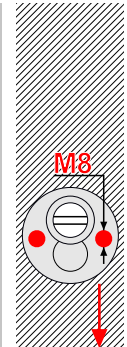
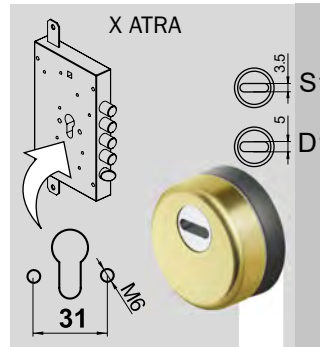
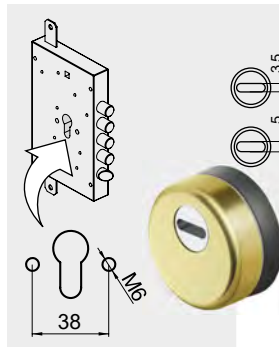
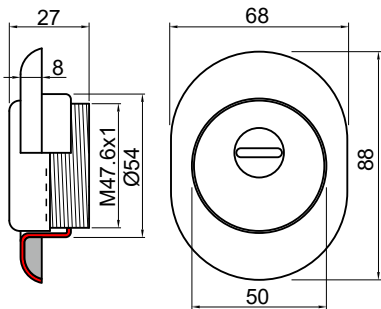



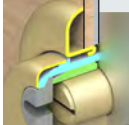

DIAMOND



OPTIONAL

OPTIONAL

| | | | | | |
|---|---|----------------------|----------------------|--|--|
|  |  | BKD251 25 .. | BKD351 25 .. | BKD250 8 25 ESEMPIO CODICE |  FINITURE Cromo lucido Bright Chrome Cromo satinato Satin Chrome Bronzo PVD Ottone PVD Brass Bronzo satinato Satin Bronze Inox satinato Satin S.Steel Nero Black |
|  |  | BKD250 25 .. | BKD350 25 .. | ESEMPIO DI CODICE PER VITI M8 EXAMPLE OF CODE FOR FIXING M8 | |
|  |  | BKT201D 25 .. | BKT301D 25 .. | | |
|  |  | BKT200D 25 .. | BKT300D 25 .. | | |

ESEMPIO CODICE / EXAMPLE CODE:

XXXXX  D1/S1 



PAT. PEND.

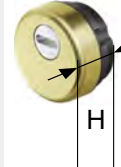
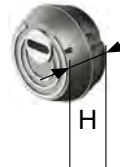

25 MA3647 25 MA3647..

FINITURE FINISHES

A1561..

- C Cromo lucido
- T Bright Chrome
- B Cromo satinato
- S Satin Chrome
- B Bronzo
- P PVD Ottone
- T Satin Brass
- TT Ottone satinato
- BS Satin Bronze
- BS Bronzo satinato
- T Satin Bronze
- IT Inox satinato
- S Satin S.Steel
- N Nero
- Black

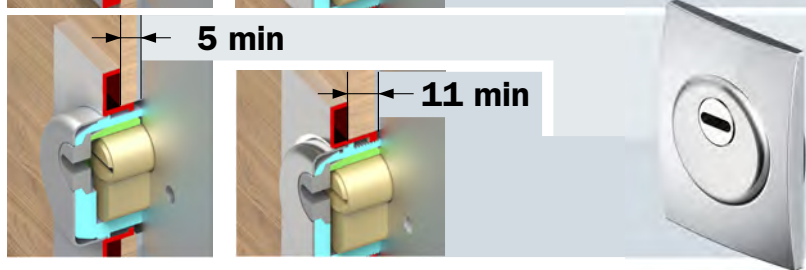
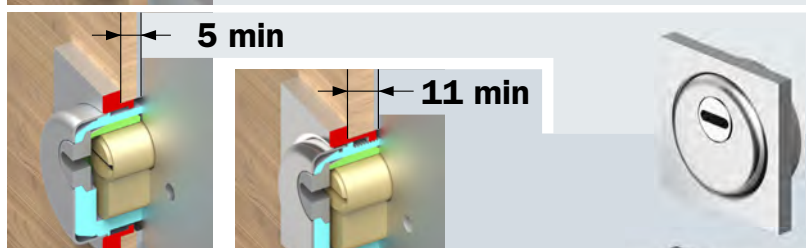
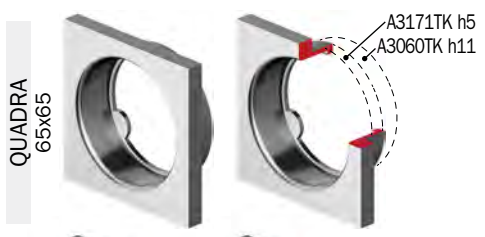
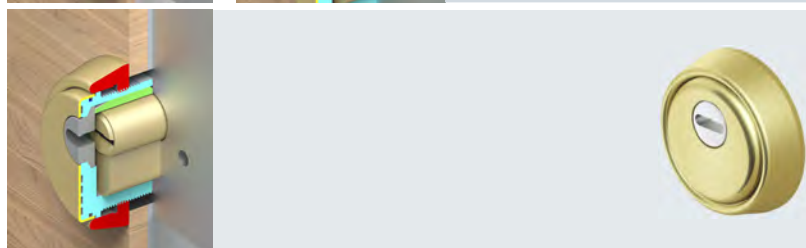
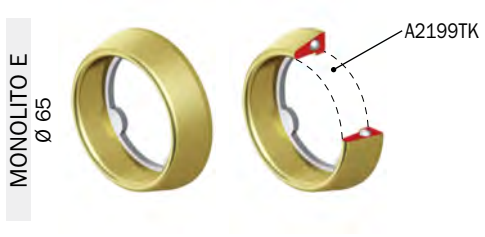
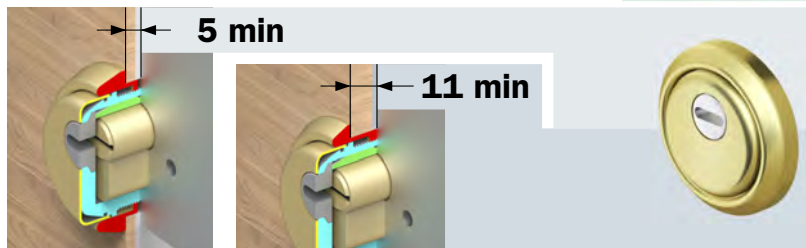
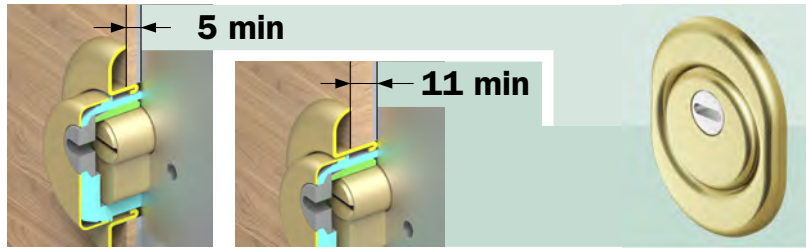
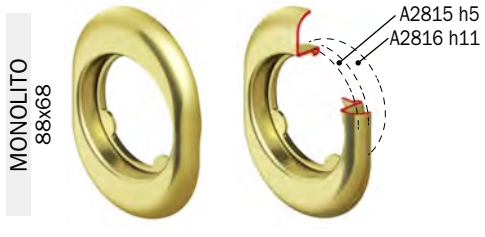
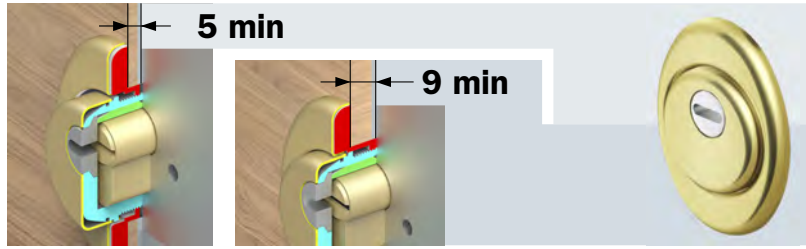
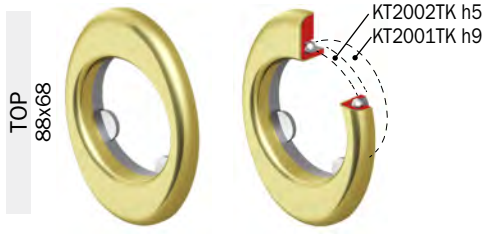
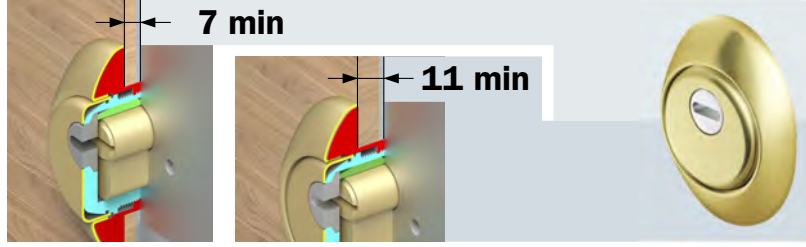
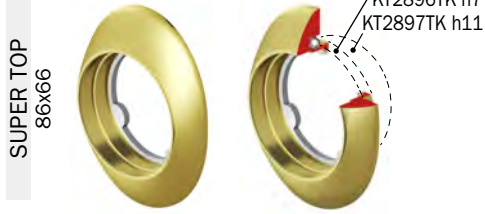

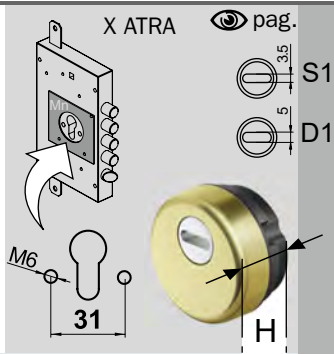
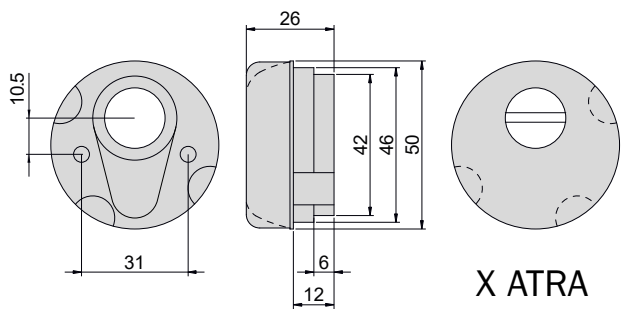

FINITURE FINISHES

- C** Cromo lucido
Bright Chrome
- T** Cromo satinato
Satin Chrome
- B** Bronzo
Bronze
- 2** PVD Ottone
PVD Brass
- IT** Ottone satinato
Satin Brass
- BS** Bronzo satinato
Satin Bronze
- IT** Inox satinato
Satin S.Steel
- N** Nero
Black



BK321ST 25



BK320ST 25



BK321T 25



BK320T 25



BK321 25



BK320 25

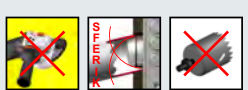

BK321M 25



BK320M 25



BK321E 25

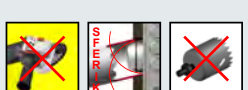

BK321Q 25



BK320Q 25



- C** Cromo lucido
Bright Chrome
- T** Cromo satinato
Satin Chrome
- 2** PVD Ottone
PVD Brass
- BS** Bronzo satinato
Satin Bronze
- IT** Inox satinato
Satin S.Steel
- N** Nero
Black



BK321W 25



BK320W 25



- C** Cromo lucido
Bright Chrome
- T** Cromo satinato
Satin Chrome
- B** Bronzo
Bronze
- 2** PVD Ottone
PVD Brass
- BS** Bronzo satinato
Satin Bronze
- IT** Inox satinato
Satin S.Steel
- N** Nero
Black