



Ministerstwo Sportu i Turystyki



10-12.06.2022



FEEL THE GRAVEL

SUPPLEMENTARY REGULATIONS
FIA European Rally Championship



FIA European Rally Championship for Drivers and Co-Drivers

FIA European Rally Championship for Teams

FIA ERC3 Championship for Drivers and Co-Drivers

FIA ERC4 Championship for Drivers and Co-Drivers

FIA ERC4 Junior Championship for Drivers

CONTENTS

I. INTRODUCTION.....	4
2. ORGANISATION.....	4
3. PROGRAMME.....	6
4. ENTRIES.....	8
5. INSURANCE.....	12
6. ADVERTISING AND IDENTIFICATION.....	13
7. TYRES.....	15
8. FUEL.....	16
9. RECONNAISSANCE.....	17
10. ADMINISTRATIVE CHECKS.....	19
11. SCRUTINEERING, SEALING AND MARKING.....	20
12. OTHER PROCEDURES.....	22
13. IDENTIFICATION OF OFFICIALS.....	28
14. PRIZES.....	28
15. FINAL CHECKS AND PROTESTS.....	29
APPENDIX 1 – ITINERARY V.I.....	30
APPENDIX 2 – RECONNAISSANCE SCHEDULE.....	32
APPENDIX 3 – NAMES AND PHOTOGRAPHS OF CROS AND THEIR SCHEDULES.....	33
APPENDIX 4 – COMPETITION NUMBERS AND ADVERTISING.....	34
APPENDIX 5 – EXTRACTS FROM FIA APPENDIX L RELATING TO OVERALLS, HELMETS AND ANY OTHER SAFETY REQUIREMENTS.....	36
APPENDIX 6 – SAS FITTING KIT MANUAL – RALLY CAR.....	37

I. INTRODUCTION

I.1. GENERAL

The rally will be run in compliance with FIA International Sporting Code (ISC) and its appendices, the 2022 FIA Regional Rally Sporting Regulations (FIA-RRSR), the National Sporting Regulations which comply with the FIA regulations, the WADA/NADA Codes, the FIA Anti-Doping Regulations and these Supplementary Regulations (SR). All FIA regulations can be found at <https://www.fia.com/regulations>.

Modifications, amendments and/or changes to these Supplementary Regulations will be announced only by numbered and dated Bulletins (issued by the Organiser or the Stewards). Additional information will be published in the Rally Guide.

During the rally, for any dispute concerning the interpretation of the regulations, only the English text will be binding.

I.2. ROAD SURFACE

The Rally stages will be run on gravel with a few short sections of asphalt on some stages (asphalt on 4% of total SS distance).

I.3. OVERALL SS DISTANCE AND TOTAL DISTANCE OF THE ITINERARY

SS Distance:	188.10 km
Total Distance:	852.33 km
Total number of Special Stages:	14 (7 different SS)

2. ORGANISATION

2.1. FIA TITLES FOR WHICH THE RALLY COUNTS

- FIA European Rally Championship for Drivers and Co-Drivers
- FIA European Rally Championship for Teams
- FIA ERC3 Championship for Drivers and Co-Drivers
- FIA ERC4 Championship for Drivers and Co-Drivers
- FIA ERC4 Junior Championship for Drivers

2.2. NATIONAL TITLES FOR WHICH THE RALLY COUNTS

- Polish Rally Championship
- MOTUL Polish Historic Rally Championship

2.3. VISA NUMBERS

FIA Visa No.:	04ERC/140422	Issued on: 14.04.2022
ASN Visa No.:	ERC/1/BSTPZM/220318	Issued on: 18.03.2022

2.4. ORGANISER'S NAME, ADDRESS AND CONTACT DETAILS (PERMANENT OFFICE)

Polski Związek Motorowy (PZM)
ul. Kazimierzowska 66
02-518 Warsaw
Poland

Phone: +48 22 542 01 16
Mobile: +48 695 525 065
E-mail: biuro@rallypoland.pl
Website: www.rallypoland.pl

2.5. ORGANISATION COMMITTEE

Jarosław Noworól
Grzegorz Lewandowski
Romuald Chałas
Krzysztof Maciejewski
Andrzej Makaran
Tomasz Lisicki
Aneta Boguszevska
Andrzej Borowczyk

Chairman of the Organisation Committee
Member of the Organisation Committee
Member of the Organisation Committee
Clerk of the Course
Deputy CoC – Chef Safety Officer
Deputy CoC – Organisation
Finance Director
Media Director

2.6. STEWARDS OF THE MEETING

Chairman (appointed by the FIA)
FIA Steward
ASN Steward
Secretary to the Stewards

Jean-Pierre Tardent (CHE)
Kostyantyn Bevz (UKR)
Marcin Fiejdasz (POL)
Katarzyna Popowicz

2.7. DELEGATES AND OBSERVERS

FIA Sporting Delegate
FIA Safety Delegate
FIA Technical Delegate
Assistant to FIA Technical Delegate
ASN Observer
ASN Technical Delegate

Anita Passalis (FIA)
Bertil Klarin (FIA)
Emanuele Saglia (FIA)
Ludovic Paturet (FIA)
Grzegorz Lewandowski (POL)
Wojciech Nowak (POL)

2.8. SENIOR OFFICIALS

Clerk of the Course
Deputy CoC – Sport
Deputy CoC – Chef Safety Officer
Deputy CoC – Organisation
Deputy CoC – Marshals
Finance Director
Media Director
Chief of the Rally Office
Chief Medical Officer
Sport Assistant and Team's Relations Coordinator
Chief Scrutineer
Accreditation Officer
Competitors Relations Officer

Krzysztof Maciejewski
Dominik Noworól
Andrzej Makaran
Tomasz Lisicki
Anna Siwińska
Aneta Boguszevska
Andrzej Borowczyk
Katarzyna Skała
Artur Gawłowski
Rafał Jaszczuk
Dariusz Marciniak
Przemysław Szews
Magdalena Lewandowska

Competitors Relations Officer (National)
Service Park Coordinator
Helicopter Coordinator
Chief Rally Control Center
Chief Timekeeper
Chief Results Officer
Environmental Coordinator

Marek Kisiel
Hubert Zdziarski
Bogdan Kozłowski
Paweł Owczyński
Bartłomiej Korzeń
Jerzy Głuśniewski
Bartłomiej Jadczyk

2.9. RALLY HQ LOCATION AND CONTACT DETAILS (from 8 June 2022 till 12 June 2022)

Hotel Gołębiewski
ul. Mrągowska 34
II-730 Mikołajki
Poland

Mobile: +48 695 525 065
E-mail: biuro@rallypoland.pl
Website: www.rallypoland.pl

Rally Office opening hours during the event:

Wednesday, 8 June 2022	18:00 – 22:00
Thursday, 9 June 2022	08:00 – 22:00
Friday, 10 June 2022	08:00 – 22:00
Saturday, 11 June 2022	07:00 – 22:30
Sunday, 12 June 2022	07:30 – 21:00

2.10. OFFICIAL NOTICE BOARD LOCATION

Only Digital Notice Board will be deployed on www.rallypoland.pl and will be also accessible in "Sportity" application in phones and tablets. The "Sportity" app can be downloaded from Google Play or AppStore. Password 78RALLYPOLANDERC must be used to enter this application. Push notifications will show if any new document is posted.

2.II. PARC FERMÉ LOCATION

After Q5, Section I and Section 3:

Hotel Gołębiewski parking with a pedestrian access to the Rally HQ and Service Park

After Section 6:

Mikołajki - ul. Dybowska

3. PROGRAMME

3.1. SCHEDULE BEFORE THE RALLY WEEK

Friday, 15 April 2022

20:00	Publication of Supplementary Regulations	www.rallypoland.pl
20:00	Opening date for entries	Acc. to Art. 4
20:00	Opening date for Media accreditation	www.rallypoland.pl

Thursday, 19 May 2022

Publication of Rally Guide 2 and maps

www.rallypoland.pl

Thursday, 26 May 2022

24:00 Closing date for entries

Acc. to Art. 4

24:00 Closing date for order of extra services in Service Park

www.rallypoland.pl

Friday, 27 May 2022

Publication of the Road Book

www.rallypoland.pl

Closing date for Media accreditation

www.rallypoland.pl

Tuesday, 31 May 2022

Publication of entry list approved by the FIA

www.rallypoland.pl

3.2. SCHEDULE DURING THE RALLY WEEK

Wednesday, 8 June 2022

08:00 Opening of Service Park

Service Park

18:00 - 22:00 Rally Office opening hours

Rally HQ

18:00 - 22:00 Registration for Reconnaissance

Rally HQ

Collection of materials and documents for Recce

Collection of rally safety tracking system for Recce

Collection of rally safety tracking system

Thursday, 9 June 2022

08:00 - 22:00 Rally Office opening hours

Rally HQ

08:00 - 20:15 Reconnaissance

Acc. to Appendix 2

12:00 - 22:00 Administrative Checks

Rally HQ

Collection of materials and documents

14:00 - 24:00 Scrutineering - sealing & marking of components

Scrutineering Hall

Checking of installation of rally safety tracking system

15:00 - 22:00 Media Centre opening hours

Rally HQ

Media accreditation

20:00 - 20:30 Pre-event Media Safety Briefing

Rally HQ

21:00 ERC Team managers briefing

Rally HQ / Zoom App.

21:30 - 21:45 Drivers Briefing

Rally HQ / Zoom App.

(mandatory for drivers and co-drivers who have

not attended a briefing at a previous 2022 ERC round)

Friday, 10 June 2022

08:00 - 22:00 Rally Office opening hours

Rally HQ

08:00 - 22:00 Media Centre opening hours

Rally HQ

Media accreditation

08:00 - 09:00 Re-Scrutineering

Scrutineering Hall

08:00 - 09:45 Reconnaissance

Acc. to Appendix 2

10:00 Publication of Start List for the Qualifying Stage

Official Notice Board

10:30 - 12:00 Free Practice for Priority Drivers

Baranowo

12:30 Start of Qualifying Stage for Priority Drivers

Baranowo

14:00 - 15:30 Shakedown for Non-Priority Drivers

Baranowo

14:30	Publication of Provisional Classification Q5	Official Notice Board
15:00	Pre-event Press Conference	Media Centre
15:15	Publication of Timetable of enter to Pre-start Park	Official Notice Board
15:15	Publication of Start List for Ceremonial Start	Official Notice Board
15:15	Publication of Start List for Leg I Section I	Official Notice Board
16:10	Pre-start Park	Mikolajki Main Square
16:30	Start order selection	Mikolajki Main Square
17:00	Ceremonial Start	Mikolajki Main Square
18:45	Start of Leg I Section I - TC O	Service Park
20:00	Publication of Start List for Leg I Section 2	Official Notice Board

Saturday, 11 June 2022

06:30	Scrutineering of restarting cars	Parc Fermé
07:00 - 22:30	Rally Office opening hours	Rally HQ
07:30	Start of Leg I Section 2 - TC IB	Parc Fermé
08:00 - 22:30	Media Centre opening hours	Rally HQ
20:15	Finish of Leg I - TC 8D	Parc Fermé
20:30	Publication of Start List for Leg 2	Official Notice Board

Sunday, 12 June 2022

06:50	Scrutineering of restarting cars	Parc Fermé
07:30 - 21:00	Rally Office opening hours	Rally HQ
07:50	Start of Leg 2 - TC 8E	Parc Fermé
08:00 - 21:00	Media Centre opening hours	Rally HQ
17:15	Finish of the Rally - TC I4D	Finish Holding-In
17:45	Podium Ceremony and Prize Giving	Mikolajki Main Square
18:00	Post-event Press Conference	Mikolajki Main Square
18:15	Final Scrutineering	Scrutineering Hall
20:00	Publication of Provisional Classification	Official Notice Board

4. ENTRIES

4.1. CLOSING DATE FOR ENTRIES

Closing date for entries: **Thursday, 26 May 2022, 24:00 hrs local time (GMT+2)**

4.2. ENTRY PROCEDURE

Those who wish to take part in ORLEN 78th Rally Poland must use the FIA Online Registration Platform. Duly completed electronic entry form must be sent before the closing date for entries. Entries are only accepted if accompanied by the full amount of entry fee.

ERC entrants who wish to score points must make their entries by using the standard entry form for their championship available in the FIA application at: <https://registrations.fia.com/rally>.

Non-Priority drivers must register and fill-in the electronic entry form available at: <https://registrations.fia.com/ercpol>.

Please note that the FIA Online Registration Platform requires a user ID and a password to access the entry system. The FIA will need time to register you in the system and open your user account. Please do not wait until the last moment to make your entry in order not to miss the entry closing date. The user account application is available via a link on the registration page stated above.

Administrative Checks will be organised remotely when entry is received. When sending your online registration entry form to FIA, please remember also to attached or send to biuro@rallypoland.pl the following documents:

- Payment confirmation of the entry fee (to ensure that payment is duly received prior to the close of entries)
- Photocopies of the Competitor, Driver and Co-Driver Competition licenses,
- Photocopies of the Driver and Co-Driver driving licenses,
- Photocopies of the Driver and Co-Driver passports or identification cards,
- Photocopy of ASN authorisation for all foreign competitors and/or drivers,
- Photocopy of vehicle registration papers,
- Photocopy of vehicle insurance cover certificate,
- Photocopy of vehicle owner authorization, if he is not one of the drivers,
- Photocopy of the page of the homologation form for the entered vehicle indicating number, group and cylinder capacity.

In case one of the above listed obligations is no fulfilled, the Organiser can reject the entry.

4.2.I. Other procedures

4.2.I.I. The competitor who wishes to receive a VAT invoice for the entry fee, fee for additional space in the Service Park or other fees must attach to the entry form or send to biuro@rallypoland.pl a billing details. In addition, the message accompanying the transfer must include the tax number for the invoice. If it is not available, it will not be possible to issue an invoice at a later date. Only after meeting this condition competitor will receive VAT invoice during Administrative Checks.

4.2.I.2. By sending the Entry Form the competitor, driver and co-driver agree for processing their personal data for the purpose of the organization of the rally and publishing photos and results in media and on the websites: www.pzm.pl and www.rallypoland.pl. Competitor/Driver/Co-Driver have the right to access, rectify abovementioned and request to stop processing their personal data. Requesting to stop processing personal data means that competitor will not participate in the rally.

4.3. NUMBER OF COMPETITORS ACCEPTED AND CLASSES

4.3.I. Number of competitors accepted

The number of entrants accepted in the rally is 80.

If more than 80 entries are received, the Organiser reserves the sole right to decide which entries among the Non-priority Drivers will be accepted.

4.3.2. Permitted classes and groups

For participation of rally cars, the article 12 of FIA-RRSR will be followed.

Classes	Groups	
RC2	Group Rally2	Group Rally2 cars conforming to the 2022 Appendix J, Art. 261
	Group Rally2 Kit (VR4K)	Cars fitted with R4 Kit conforming to the 2022 Appendix J, Art. 260E
	Group NR4 over 2000cc	Group N cars conforming to the 2019 Appendix J, Art. 254
	S2000-Rally: 2.0 Atmospheric	Super 2000 cars (conforming to the 2013 Appendix J, Article 254A)
RGT	RGT cars	Group RGT cars conforming to the 2019 or 2022 Appendix J, Art. 256
RC3	Rally3 (atmo over 1390cc and up to 2000cc and turbo over 927cc and up to 1620cc)	Group Rally3 cars homologated from 01/01/2021 and conforming to the 2022 Appendix J, Art. 260
RC4	Rally4 (atmo over 1390cc and up to 2000cc and turbo over 927cc and up to 1333cc)	Group Rally4 cars homologated from 01/01/2019 and conforming to the 2022 Appendix J, Art. 260 Group R2 cars homologated before 31/12/2018 and conforming to the 2018 Appendix J, Art. 260
	R3 (atmo over 1600cc and up to 2000cc and turbo over 1067cc and up to 1333cc)	Group R cars homologated before 31/12/2019 and conforming to the 2019 Appendix J, Art. 260
	R3 (turbo up to 1620cc / nominal)	Group R cars homologated before 31/12/2019 and conforming to the 2019 Appendix J, Art. 260D
	Group A up to 2000cc	Group A cars conforming to the 2019 Appendix J, Art. 255
RC5	Rally5 (atmo up to 1600cc and turbo up to 1333cc)	Group Rally5 cars homologated from 01/01/2019 and conforming to the 2022 Appendix J, Art. 260
	Rally5 (atmo up to 1600cc and turbo up to 1067cc)	Group R1 cars homologated before 31/12/2018 and conforming to the 2018 Appendix J, Art. 260

FIA Technical passport is mandatory for S2000, Rally2 and RGT cars.

4.4. ENTRY FEES AND ENTRY PACKAGES

4.4.I. Entry fees

			ERC Priority			
			ERC1	ERC3	ERC4	ERC4 Junior
ERC registered entrant	Legal entrant	With the optional advertising	3500 Euro	3000 Euro	2500 Euro	1000 Euro
		Without the optional advertising	5500 Euro	5000 Euro	4500 Euro	2000 Euro
	Private entrant	With the optional advertising	3000 Euro	2500 Euro	2000 Euro	1000 Euro
		Without the optional advertising	5000 Euro	4500 Euro	4000 Euro	2000 Euro

			Class		
			RC2 / RGT	RC3	RC4 / RC5
ERC non-registered entrant	Legal entrant	With the optional advertising	3500 Euro	3000 Euro	2500 Euro
		Without the optional advertising	5500 Euro	5000 Euro	4500 Euro
	Private entrant	With the optional advertising	3000 Euro	2500 Euro	2000 Euro
		Without the optional advertising	5000 Euro	4500 Euro	4000 Euro

Private entrant: Car entered by a member of the crew who competes under his/her own name or pseudonym.

Legal entrant: Car entered by a team or a company or other legal entity, holding a valid legal entrant's licence.

Entry will be published only if the payment has been received.

Other fees:

Entry for Reconnaissance only 300 Euro

Auxiliary plate 200 Euro

4.4.2. Entry packages

	Legal entrant	Private entrant	ERC4 Junior
Area in Service Park			
ERC registered team	150m ² for 1 car +50m ² for each additional car	100m ² for 1 car +50m ² for each additional car	90m ² for 1 car +50m ² for each additional car
Non-registered team	120m ² for 1 car +50m ² for each additional car	80m ² for 1 car +50m ² for each additional car	70m ² for 1 car +50m ² for each additional car
Vehicle Plates per car			
VIP (or guest) plates	1	0	0
Service plates	2	1	1
Auxiliary plates	1	1	0
Printed material and Passes per car			
Road book sets	2	1	1
Programmes	2	1	1
Recce road book	Will not be printed - available only at www.rallypoland.pl		
Regulations	Will not be printed - available only at www.rallypoland.pl		
Service road book	Will not be printed - available only at www.rallypoland.pl		
Rally Guide	Will not be printed - available only at www.rallypoland.pl		
Passes per car			
Crew	2	2	2
Team	8	6	6

At the request of the competitor, in case of the space availability, the Organiser may provide additional area in the Service Park for extra charge (priority will be given to competitors – legal entrants). Additional space can be ordered for a price of 12 Euro per 1 m².

Order forms of additional space and adjacent space in the Service Park are available at www.rallypoland.pl (Competitors section).

Other additional resources subject to negotiation between the competitor and the Organiser.

4.5. PAYMENT DETAILS

The entry fee must be paid to the following bank account:

Bank:	Santander Bank Polska S.A.
Account No:	43 1500 1777 1217 7007 8348 0000
IBAN:	PL 43 1500 1777 1217 7007 8348 0000
Swift code:	WBKPPLPP
Bank key/Sort code:	1500 1777 12
Account holder:	Polski Związek Motorowy – Zarząd Główny ul. Kazimierzowska 66 02-518 Warsaw Poland

Any bank charges incurred must be paid by the entrants in addition to the entry fees.

Please ensure that the entrant's name and account holder are included as reference on all bank transfers.

4.6. REFUNDS

Entry fees will be refunded in full only:

- to candidates whose entry has not been accepted
- in the case of the rally not taking place

The Organiser may refund up to 50% of the entry fee to those competitors who, for reason of "force majeure" (duly certified by their ASN), were unable to start the rally. **The application for a refund, stating the reason for not starting, must reach the Organiser in writing to biuro@rallypoland.pl before the start of the Administrative Checks.** Bank account details must be included.

5. INSURANCE

5.1. INSURANCE COVERAGE FOR THE ORGANISER

5.1.1. Organiser's liability insurance

The Organiser has concluded an insurance contract with PZU S.A. contract No. 1070497102, with Organiser's liability insurance covering damage caused to a third party during the competition up to 5 000 000 Euro.

The insurance cover will come into effect from the start of the rally and will cease at the end of the rally or at the moment of permanent retirement or disqualification. Cars having retired and restarted shall not be considered to have permanently retired. Crews participating in the Shakedown, Free Practice and Qualifying Stage, will be insured for its duration under the same policy.

5.1.2. Damage caused to the third party

A part of the insurance contract No. I070497I02, concluded with PZU S.A. is coverage for damages caused to a third party. However, damages caused by drivers among themselves are not covered by this contract.

5.1.3. Car third party liability insurance

All crews at Administrative Checks have to hand in a valid motor third party liability insurance policy for their car - International Green Card. Without this card, the crew won't be permitted to start.

5.2. INSURANCE COVERAGE FOR COMPETITORS AND CREWS

All the drivers and co-drivers are obliged to arrange their own accident insurance. The proof should be documented on request at Administrative Checks. The insurance of foreign crews has to cover the costs of possible medical treatment in Poland and their repatriation, if necessary, in the event of an accident.

By the fact of signing the entry form, the competitors and/or drivers relinquish any claims to compensations of any kind which might result due to incidents during the Rally. The relinquishment is applied to FIA, ASN and the Organiser, officials and other competitors and/or drivers.

5.3. DAMAGE REPORTING

The competitor or his representative are obliged to notify the Clerk of the Course in writing about any damage caused on the track by their car as quickly as possible and within 24 hours. Violation of this duty stands for summoning the competitor and involved crew to a disciplinary committee. He must explain the circumstances under which the accident occurred. Likewise, he must mention the names and addresses of any witnesses.

5.4. INSURANCE COVERAGE EXCLUSIONS

Service and auxiliary vehicles, cars dedicated to reconnaissance rides and other vehicles with special plates issued by the Organiser are not covered by the provided rally insurance (with the exception of insured Organiser's cars) and those are always going on their own responsibility.

6. ADVERTISING AND IDENTIFICATION

6.1. RALLY PLATES AND IDENTIFICATION NUMBERS

Competitors will be required to carry mandatory rally identification plates and competition numbers issued by the Organiser according to Art. 27 of the 2022 FIA Regional Rally Championships Sporting Regulations. Those must be affixed to the car for Scrutineering as shown in Appendix 4 of these

regulations and must be visible for the duration of the rally. The mandatory advertising will be concern to the following subjects, companies and brands: ORLEN, FIA, ERC, PZM (Polish Automobile and Motorcycle Federation), Warmia Mazury (region located in north-east Poland).

6.2. ORGANISERS ADVERTISING

The optional Organiser's advertising will be concern to the following subjects, companies and brands: PZM, ORLEN, RMF FM/RMF MAXX (national radio), WP SportoweFakty (national sports information portal). No modification of the advertising is allowed.

6.3. LOSS OR REMOVAL OF COMPETITION NUMBERS AND ADVERTISING

Competition numbers, rally plates and optional advertising must not be modified or removed. Failure to comply with any regulations concerning the plates and identification numbers will be sanctioned as follows:

- One missing rally plate or competition number: fine of 150 Euro.
- Both competition numbers or rally plates are missing at the same time: reported to the Stewards.
- missing Organiser's optional advertising at any moment:
 - ERC1, ERC3, ERC4 – fine of 2000 Euro.
 - ERC4 Junior – fine of 1000 Euro.
 - ERC non-registered entrant – fine of 2000 Euro.

6.4. ADVERTISING RESTRICTION

6.4.1. No political, religious or abusive advertising. Advertising for alcoholic beverages and tobacco are forbidden. These laws apply to competing cars, service cars, team equipment and clothes.

6.4.2. The Organiser of the ORLEN 78th Rally Poland have the exclusive rights to run every kind of promotional, advertising and commercial activities in the Service Park, Parc Fermé, Rally Fan Park, Start and Finish area, Scrutineering places, premises of rally HQ i.e. the area and surroundings of Hotel Gołębiowski and the entire route of the rally and the vicinity understood as the area remaining within the eyesight from the route of the rally. This applies to every portion of the road i.e. both the special stages and the road sections. Each company interested in running any promotional, advertising or commercial activities at the rally should contact the Organiser with suitable advance and sign the agreement.

6.4.3. The Organiser has the right to undertake suitable legal action according to civil and sporting law in order to remove immediately every effect of unauthorized activities including any advertising medium and commercial or exhibit booth.

6.4.4. Every competitor and every crew entered to the rally have the right to display the advertising media of their sponsors only on their vehicles (including the competing car), garments of the team members and within the area of their space in the Service Park provided that these media will be installed in such a way that they do not cause the danger to people and objects nearby.

6.4.5. The Clerk of the Course has the right to bring every case of unauthorized activities to the Stewards who may impose the penalty on the competitor/team who was found guilty.

7. TYRES

7.1. TYRES SPECIFIED FOR USE DURING THE RALLY

All tyres must be readily available commercially and must comply with Art. 13 and Appendix V of the 2022 Regional Rally Sporting Regulations.

7.1.1. Tyres for all ERC1, ERC3 and ERC4 priority competitors

Tyres must be supplied by an FIA-nominated tyre company. A list of nominated tyre manufacturers for the FIA European Rally Championship is published on fia.com.

7.1.2. Tyres for ERC4 Junior Championship

For the ERC4 Junior Championship, only PIRELLI tyres, sold at the rallies by the ERC4 Junior Championship tyre supplier, are eligible.

A driver may use only those tyres that have been registered for his car. Any tyre registered for a driver at a previous rally must be presented at the tyre supplier for checking and new registration before it can be used on a rally by the same driver.

Competitors registered for the ERC4 Junior Championship must use the following type of tyres:

Tyre Manufacturer	Size	Name	Usage
PIRELLI	185/70-15	Scorpion K6	Soft
	185/70-15	Scorpion K4	Hard

7.2. TYRES QUANTITIES

The quantities of tyres for use during the rally by all drivers are as follows:

Class	Quantity
RC2 and RGT	16
RC3, RC4 and RC5	12

The maximum quantity for ERC4 Junior drivers for whole event is 12, to be chosen from the list below:

Name	Quantity
Scorpion K6	12
Scorpion K4	6

For competitors eligible to take part in Qualifying, tyres will be taken from the overall quantity, except the spare wheel(s) fitted in the car.

For Free Practice and Shakedown tyres will not count for the overall quantity.

7.3. TYRES MARKING

Only tyres marked by the Organiser may be used. Any infringement to this rule will be reported to the Stewards.

7.3.1. Tyre marking locations

Tyre marking for the tyres that will be used during the Qualifying Stage will take place just before the start of Qualifying Stage.

Tyre marking for the tyres that will be used during the rally will take place at the exit of the Service Park located in Mikolajki.

7.3.2. Tyres will be checked for their conformity during the rally.

7.4. TYRES FOR USE ON RECONNAISSANCE

Free tyres for gravel.

8. FUEL

8.1. FUEL RESTRICTIONS

Fuel must be in compliance with FIA ISC 2022 Appendix J.

8.1.1. Fuel restrictions for ERC4 Junior

Competitors in the ERC4 Junior Championship are allowed to use only pump filling station fuel (gasoline type 98) from the following petrol station:

- ORLEN – Prawdowo 8, II-730 Mikolajki; GPS Coordinates: N 53°48.150; E 21°33.048

Service crews are allowed to fill this fuel in their canisters, and refuel ERC4 Junior cars in designated Refuelling Zones.

8.2. REFUELLING

8.2.1. Refuelling Zones

Except as detailed in Art. 58 of FIA RRSR, competitors may refuel only in the designated Refuelling Zones and commercial filling stations marked in the Road Book.

8.2.2. Refuelling procedure

Solely for the purpose of assisting with the refuelling procedure of their car, two team members of each crew with the team passes may access the Refuelling Zone. In order to access the RZ, all personnel involved in refueling operations must wear clothing that provides adequate protection against fire and includes at least: long trousers, long-sleeved top, closed shoes, gloves and a balaclava.

Engines must be switched off throughout the refuelling operation. **It is required that the crew remain outside the car during refuelling.**

The Organiser will provide to each competitor an Environnement Mat to protect the ground.

9. RECONNAISSANCE

9.1. PROCEDURE FOR REGISTRATION

Reconnaissance registration and collection of materials and documents, including Road Book, will take place as follows:

Rally HQ

Wednesday, 8 June 2022

18:00 – 22:00

9.1.1. Registration form

The Reconnaissance registration form including details of the car that will be used during Reconnaissance must be completed and submitted during the registration. This form is available at www.rallypoland.pl (Competitors section).

9.1.2. Participation in Reconnaissance Only

Any driver holding an appropriate international license and not entered in the rally may apply to take part in the Reconnaissance. The registration form for this purpose must be sent by e-mail to biuro@rallypoland.pl before the closing date for entries. The final permission for taking part in Reconnaissance is left to the discretion of the Clerk of the Course. The fee for taking part only in Reconnaissance is 300 Euro. The regulations on Reconnaissance must be respected in their entirety.

9.2. RECONNAISSANCE TIME SCHEDULE

Reconnaissance will be held according to the schedule specified in Appendix 2 of these Supplementary Regulations. The schedule of Reconnaissance must be fully respected by the crews.

9.3. RECONNAISSANCE RULES AND SPECIAL RESTRICTIONS

9.3.1. General

Reconnaissance will be organised in compliance with Art. 35 of FIA Regional Rally Sporting Regulations.

9.3.2. Reconnaissance cars

Reconnaissance may only be carried out with the use of cars in accordance with FIA Regional Rally Sporting Regulations (Art. 35.I).

Reconnaissance cars must have the insurance policy according to Polish Traffic Law regulations. The Organiser accepts no responsibility on this matter.

If a competitor taking part in Reconnaissance wishes to change the car, it has to inform the Rally Office and provide the details of the replacement car. Failure to follow this procedure will result in refusal to participate in the Reconnaissance. The Reconnaissance stickers have to be placed on the replacement car.

9.3.3. Identification numbers

The Reconnaissance numbers supplied during registration must be attached onto the Reconnaissance car on the top of the front and rear windscreen (Co-driver's side). They must be visible for the duration of the Reconnaissance period.

9.3.4. Number of passages

Competitors are permitted a maximum of two passages over each special stage during Reconnaissance. All stages driven more than once in the rally will be considered as one stage for Reconnaissance purposes.

9.3.5. Driving direction

Under no circumstances may competitors drive in the opposite direction of the rally traffic, except in cases described in Recce Road Book (competitors may drive from the finish to the start of special stage using road which is a short part of the stage in the opposite direction of the rally traffic).

The speed limit on this part of stages during Reconnaissance is 40km/h.

Competitors may only enter a special stage through the start and exit through the finish.

The special stages will be open to normal traffic, therefore safety and rights of other road users must be respected. Competitors are reminded that vehicles may be travelling in the opposite direction.

Any infringement will be reported to the Stewards.

9.3.6. Reconnaissance control card

Reconnaissance Control Card will be issued to the crews at registration and must be carried in the car for the duration of the Reconnaissance. This card will be signed appropriately recording every run on each special stage. Failure to produce this card will result in refusal to participate in the Reconnaissance. Reconnaissance Control Card must be returned after Reconnaissance at the stop point of the last Special Stage.

9.3.7. Illegal Reconnaissance

Any member of the crew, taking part or intending to take part in the rally, who is found on the route of any special stage outside of the listed Reconnaissance dates and times and before the moment when a special stage is terminated, open for public traffic and will no longer be used within the rally, will be deemed to be performing illegal Reconnaissance. Any infringement will be reported to the Stewards.

9.3.8. Speed limits

Competitors must fully respect the Polish Traffic Law regulations, including use seatbelts and speed limits:

- 50 km/h in the built-up area (if the signs does not show otherwise),
- 90 km/h outside the built-up area (if the signs does not show otherwise).

Maximum speed allowed during Reconnaissance is 70 km/h on special stages, unless a lower speed limit is indicated by traffic signs or by written instructions in the Road Book or Bulletin.

All Competitors must note that there will be police controls to prevent speeding or other road infringements. Any speeding offence whether recorded by police or officials on a special stage or on a road section, will result in a fine as shown in 2022 FIA-RRSR Art. 34.2. The fitting or carrying of radar detection equipment during Reconnaissance is forbidden.

9.4. INSTALLATION OF SPEED CONTROL CHECKING DEVICES

The Organiser will provide a speed control checking devices (PZM-GPS safety tracking system), which has to be used during Reconnaissance in the Reconnaissance car. The progress of the Reconnaissance will be monitored via GPS system, by rally officials. Evaluation of the GPS data is within the competence of Clerk of the Course. Reconnaissance cars not equipped with a working PZM-GPS safety tracking system will be reported to the Stewards.

Collection of PZM-GPS safety tracking system for Recce will be possible during Administrative Checks on Wednesday, 8 June 2022, 18:00 – 22:00, in Rally HQ. The equipment should be disassembled from the Reconnaissance car on Friday, 10 June 2022 and must be returned to Rally Office not later than 12:00.

Crews are materially responsible for PZM-GPS safety tracking system installed in his car. In case of damage of this system through fault of the competitor during the Reconnaissance, he is obligated to compensate the damage before the first Stewards Meeting.

10. ADMINISTRATIVE CHECKS

10.1. DOCUMENTS TO BE PRESENTED

According to Art. 4.2 Administrative Checks will be organised remotely when entry is received. **Drivers and Co-drivers are not required to be present at Administrative Checks.** Each Competitor may nominate in advance one authorized representative to complete Administrative Checks and collect the materials and documents.

At Administrative Checks the representative of competitor shall present:

- Duly completed and signed original entry form,
- Valid Competitor's license,
- Valid Driver's and Co-driver's competition licenses.

He also must be prepared to present an originals of all other required documents mentions in Art. 4.2 except Driver's and Co-driver's driving licenses.

Valid Driver's and Co-driver's driving licenses should be presented on Wednesday, 8 June 2022, 18:00 - 22:00, during Reconnaissance registration or on Thursday, 9 June 2022, in Rally Office, after the first day of Reconnaissance, no later than at 22:00.

10.2. TIMETABLE

Administrative Checks will take place at the rally secretariat as follows:

Thursday, 9 June 2022 12:00 - 22:00

Individual times will be published by Bulletin. Any delay at Administrative Checks will be penalized by 30 Euro for each 10 minutes delayed. If the delay exceeds 30 min the competitor will be reported to the Stewards. In reasonable and well justified cases, the Organiser can arrange an alternative time for the competitor.

All competitors must pass Administrative Checks before proceeding to pre-event Scrutineering.

II. SCRUTINEERING, SEALING AND MARKING

III. SCRUTINEERING LOCATION AND TIMETABLE

Location: Scrutineering Hall located at Hotel Gołębiewski parking
Date: Thursday, 9 June 2022 (Friday, 10 June 2022 - Re-Scrutineering)
Time: 14:00 - 24:00 (08:00 - 09:00 - Re-Scrutineering)

Individual times will be published by Bulletin. Any delay at Scrutineering will be penalized by 30 Euro for each 10 minutes delayed. If the delay exceeds 30 min the crew will be reported to the Stewards. Cars may be presented at Scrutineering by the crew or a representative of the team.

II.2. DOCUMENTS TO BE PRESENTED:

- Filled out Scrutineering card,
- Filled out a Driver/Co-driver Safety equipment card,
- Vehicle FIA technical passport, when it's applicable,
- Vehicle ASN technical passport, when it's applicable,
- Vehicle original FIA homologation form.

II.3. SEALING AND MARKING

II.3.1. For each Rally2 car the Competitor must submit before the Scrutineering the joker list nomination fulfilled and signed to the following e-mail: erc-technical@fia.com.

II.3.2. After pre-rally Scrutineering, any change of sealed component must be notified by the competitor to the following email: erc-technical@fia.com. This notification must be received prior to the change of part.

II.4. MUD FLAPS

Transversal mud flaps are mandatory and must comply with Appendix J Art. 252.7.7.

II.5. WINDOWS/NETS

In accordance with Appendix J Art. 253.ii, the use of silvered or tinted films is authorised, on the rear side windows, on the rear window and on the sunroof. Silvered or tinted films fitted on rear side windows must have an opening equivalent to the surface of a circle of 70 mm in diameter.

II.6. DRIVER'S SAFETY EQUIPMENT

Drivers safety equipment will be checked at Scrutineering. For specifications, see Appendix 5.

II.7. NOISE LEVEL

At any time on the road sections, the noise level must be in conformity with Appendix J. See also FIA Regional Rally Sporting Regulations Art. I8.3.

II.8. ON-BOARD CAMERAS

The competitor of any car which carries an on-board camera must have the prior agreement of the ERC Promoter. Authorized cameras will be identified by an adhesive decal and must be mounted in the car at the time of Scrutineering.

Competitors wishing to use a camera must supply the following information to the ERC Promoter (accreditation@fiaerc.com) at least one week before the start of Reconnaissance:

- Competitor's name, car number,
- Competitor's address,
- use of footage,
- brand and model name of the device(s) used.

II.9. SPECIAL REQUIREMENTS

II.9.1. Each car must be equipped with one red reflective triangle and a first aid kit.

II.9.2. Competitors are reminded that two belt cutters must be carried on board at all times. They must be easily accessible to driver and co-driver when seated with their safety belts fastened.

II.10. INSTALLATION OF RALLY SAFETY TRACKING SYSTEM

II.10.1. All cars must be fitted with the SAS Safety Tracking System. Any competitor with a competition car without properly mounted and fully operational the SAS Safety Tracking System will not be authorized to start: Free Practice, Qualifying Stage, Shakedown and the Rally.

II.10.2. Competitors will receive SAS Safety Tracking System in Rally HQ (SAS Office) during registration for Reconnaissance on Wednesday, 8 June 2022, 18:00 – 22:00. Systems may be collected either by the crew or a representative.

A 1200 Euro fully refundable credit card deposit will be collected by SAS from each competitor for the safety tracking boxes. This will be done by blocking the full amount and releasing it once the equipment is returned in good condition.

II.10.3. Competitors must have installed the SAS Safety Tracking System in their rally cars before the car is brought to Scrutineering. The system will be checked during Scrutineering. For installation and operating instructions see Appendix 6.

II.10.4. SAS Safety Tracking System devices can be removed in the Final Parc Fermé and returned to SAS Office no later than 30 minutes after the opening of the Final Parc Fermé. Should a crew retire, the equipment must be returned immediately to SAS.

12. OTHER PROCEDURES

12.1. FREE PRACTICE AND QUALIFYING STAGE, SHAKEDOWN

Free Practice and Qualifying Stage will be organised according to 2022 FIA-RRSR – Via ERC Art. 37.

12.1.1. Location

Free Practice, Qualifying Stage and Shakedown will be held in Baranowo, about 10.5 km from Service Park in Mikolajki. The stage is 3.46 km in length. Service Zone and Refuelling Zone for Free Practice and Qualifying Stage will be located in the main Service Park in Mikolajki: Hotel Gołębiewski parking - Mikolajki, ul. Mrągowska 34.

12.1.2. Only competitors, who passed Administrative Checks and Scrutineering, can participate in Shakedown, Free Practice and Qualifying Stage. Competition numbers and advertising stickers must be affixed to their cars. It is compulsory to wear the safety equipment of driver and co-driver as for normal Special Stage.

12.1.3. Any passenger on board the car during Free Practice / Shakedown who is not entered for the rally must have signed a disclaimer provided by the Organiser. The form will be available in the Rally Office and at Free Practice / Shakedown start.

12.1.4. Shakedown is intended for drivers who did not participate in Qualifying Stage. FIA and ERCI Priority drivers (registered drivers) entered with Rally2 group cars will not be allowed to participate in Shakedown. Shakedown is free of charge for participants.

12.2. START PROCEDURE AND ORDER

12.2.1. Pre-start Park

Before the Ceremonial Start, for all competitors participating in the rally, will be organized the Pre-start Park at the Mikolajki Main Square. Competitors must park their cars in pre-start area strongly according to the timetable which will be published on Friday, 10 June 2022 at 15:15 on the Official Notice Board. Any delay or early arrival will be penalized by 100 Euro. Cars may be driven by the crew or a representative of the team.

12.2.2. Start order selection

The selection of start positions, according to 2022 FIA-RRSR – Via ERC Art. 37.8, will take place on Friday, 10 June 2022 at 16:30 at the Mikolajki Main Square. Only drivers are required to attend.

12.2.3. Ceremonial Start

The Ceremonial Start will take place at the Mikolajki Main Square on Friday, 10 June 2022 at 17:00. The starting order for the Ceremonial Start will be published on Friday, 10 June 2022 at 15:15 on the Official Notice Board. The crews will start from the lowest to the highest starting numbers.

The crews must wear overalls and attend the Ceremonial Start with their competition cars. If any crew is unable to participate in the Ceremonial Start because of technical problems with their car, they will be permitted to start into the Leg I at TC O in its allocated start time on condition of notification to the Clerk of the Course and passing the obligatory Re-scrutineering Checks. The concerned crew must attend the Ceremonial Start wearing overalls at their due time anyway.

12.2.4. Official start of the rally

The official start of the rally will take place at the TC O (Service - Out) on Friday, 10 June 2022 at 18:45. The starting order for Leg I (Section I) will be published on Friday, 10 June 2022 at 15:15 on the Official Notice Board.

Parc Fermé before the TC O will not be organised.

Tyre Marking Zone and Refuelling Zone will be located after TC O.

12.3. START INTERVALS

The start interval will be:

- during Qualifying Stage – 2 minutes for all crews.
- during Ceremonial Start – 1 minute for all crews.
- during the rally (except SSS 1/8 Mikolajki Arena) – 2 minutes for all crews.
- during SSS 1/8 Mikolajki Arena – 4 minutes for all crews (the cars will start in pairs).

12.4. SUPER SPECIAL STAGE PROCEDURE AND ORDER

12.4.1. SSS 1/8 Mikolajki Arena will be run under Super Special Stage regulations. At this SSS two cars will start at the same time on parallel positions. The cars will follow the route of the stage, changing lanes in a tunnel/bridge combination and will cross the finish line at the same position where they started. At the Time Control before SSS 1/8 Mikolajki Arena competitors will be paired for the Super Special Stage. The instructions given by the marshals must be respected.

12.4.2. During SSS I the car which will be first on the Starting List will be directed to the right track, the second car will be directed to the left track. The same rule will apply to each pair of competitors. During SSS 8, the car which will come first to Time Control will be directed to the right track, the second car will be directed to the left track. The same rule will apply to each pair of competitors.

12.4.3. If the running of the SSS 1/8 is interrupted, this will be signaled to the drivers by red flag. When given this signal, the driver must immediately reduce speed and follow the instructions of any marshals or other officials. Failure to comply with this rule will entail a penalty at the discretion of the Stewards. If the super special stage is interrupted or stopped for any reason, Art. 52 of the 2022 FIA-RRSR will apply.

12.4.4. The maximum time for SSS 1/8 Mikolajki Arena is 5 minutes. Any crew which fails to complete the SSS within this maximum time will be considered retired, with the possibility to re-start the rally in accordance to Art. 54 of the FIA Regional Rally Sporting Regulations. Should a car stop in SSS, it will immediately be towed, transported or pushed to the road section after the STOP control by the Organiser. Any such car will be penalised as in the 2022 FIA Regional Rally Sporting Regulations Art. 54.2 and will be deemed to re-start from TC IB or TC 8E, respecting the requirements of FIA-RRSR Art. 55, unless the competitor notifies the Organiser otherwise.

12.5. RE-START AFTER RETIREMENT

12.5.1. A crew which has failed to complete a section may be assumed to re-start the rally from the start of the next section following the overnight regroup unless they confirm otherwise with the Clerk of the Course by completing of the form located in the rear of the road book ("final retirement") and lodging it with the Organiser as soon as possible and, if feasible, before the publication of the re-start list. The car must report to the overnight Parc Fermé prior to the next section following the overnight regroup, no later than 1 hour before the scheduled start of the 1st car. Re-scrutineering will be 1 hour before the start of the 1st driver.

12.5.2. Parc Fermé for re-starting cars

There will be no dedicated Parc Fermé for re-starting cars. These will use the same Parc Fermé as for the rest of the event but will be placed separately in order to be identified.

12.6. STARTING SYSTEM OF SPECIAL STAGES

At the start to each Special Stage there will be located an electronic starting equipment with digital display. It will be connected with the photocell for detecting a false start. The photocell will be located 50 cm after the start line. The countdown will be discounted second by second and an electronic display will be clearly visible to the crew from the start line. Within this 20 seconds the crew is obliged to start (according to Art. 48.4.3 2022 FIA-RRSR).

12.7. SERVICE PARK

12.7.1. Service Park location and timetable

Only one Service Park located in Mikolajki will be organised during the Rally. Surface: mixed hard surface.

Location: Hotel Gołębiewski parking - Mikolajki, ul. Mrągowska 34.

Date: from Wednesday, 8 June 2022, 08:00

12.7.2. Access

Service Park can be entered only with competition cars, Service cars (SERVICE plates) and Auxiliary vehicles (AUXILIARY plates). All plates must be affixed to the upper side of the windscreen on the right (passenger) side. Removal of the sticker is prohibited until the end of the rally.

Reconnaissance cars and VIP vehicles are not allowed to enter the Service Park. Nearby Parking area will be available for the other registered vehicles (Recce/VIP).

12.7.3. Service area

The competitor is obliged to service only within the allocated service area in the Service Park. These regulations will be controlled by the Service Park Coordinator. Any infringement in this field will result in charging a double fee for additional service area.

12.7.4. Maximum speed

Maximum speed inside the Service Park is limited by 30 km/h. Failure to comply with this limit shall result in a penalty applied by the Clerk of the Course as follows: 25 Euro per kilometer per hour over the speed limit.

12.7.5. Catering within the Service Park

Apart from the provision of a catering service for the drivers and service crew personnel of a team, any other form of catering or sale of food and beverages in the service park is prohibited. The only exception is where a written agreement has been entered into between a team and the Organisers. A fine of 1 000 Euro will be applied in respect of any infringement of this regulation. The Organiser will provide a catering service within the Service Park for all team personnel and spectators.

12.7.6. Shows and exhibitions in service area

If any team or company would like to organise shows or exhibitions for their guests in service area, they must ask the Organiser for permission before Administrative Checks. All shows and exhibitions in service area without permission of the Organiser are strictly forbidden.

12.7.7. Tidiness

All crews are obliged to use a liquid-proof tarp under competition cars. Drilling or any other damages to the surface of the Service Park have to be avoided. Each Competitor is liable for the damages to the Service Zone allocated to them. The crews are responsible for the removal of their waste and sewage. After the rally, the Service Park has to be handed over in tidy condition. Failure to comply with this rule will result in a financial penalty 300 Euro applied by the Clerk of the Course.

12.7.8. Flexi Service

For the operation of 45' flexi-servicing, crews will enter the Parc Fermé. After a minimum 10 minutes stay crews may then either enter the Service Park or leave their car in the Parc Fermé. According to Art. 59.2.2 of the 2022 FIA-RRSR, the competing car may be driven by an authorised representative of the competitor only from the Parc Fermé to the Service Park (TC 8B "Parc ferme & Technical Zone - Out / Flexi Service - In") and vice versa (from TC 8C "Flexi service - Out" to TC 8D "Parc ferme - In") respecting all the formalities of time card presentation and related penalties. The competing car may be conducted to the overnight Parc Fermé before the 45 minutes have elapsed without penalty. All cars except re-starting crews have to be in the overnight Parc Fermé no later than at 23:30.

12.8. ENTRANCE TO THE REGROUPING AREA AND PARC FERMÉ

12.8.1. Safety GPS tracking

SAS Safety Tracking System workers are allowed to enter the Regrouping area and Parc Fermé in order to maintain or repair the SAS Safety Tracking System installed in the rally cars. They have to be accompanied by Scrutineer and at least one representative of the team (driver, co-driver and/or competitor).

12.8.2. TV Crews

TV Crews, which names will be published by the Clerk of the Course communication, are allowed to enter the Regrouping area and Parc Fermé in order to maintain the camera systems installed in the rally cars or to exchange the data recording media. They have to be accompanied by Scrutineer and at least one representative of the team (driver, co-driver and/or competitor).

12.9. POWER STAGE

With reference to Art. 50 of the FIA-RRSR SS 14 Milki 2 will be run as the Power Stage.

12.10. FINISH PROCEDURE

The competition part of the rally ends at TCI4D (Finish – Holding - In).

The Ceremonial Finish will take place at the Mikolajki Main Square on Sunday, 12 June 2022 at 17:45. First three crews of the rally will be awarded on the podium. Other prizes according to the Art. 14.2 of these Supplementary Regulations will be over-given on the finish ramp.

After the Ceremonial Finish, competitors are obliged to go straight to the final Parc Fermé and they must follow the route described in the Road Book. Cars are subject to Parc Fermé rules from the moment they reach the end of the competition element of the rally (TCI4D) until the Stewards have authorised the opening of the Parc Fermé.

12.11. FINAL PARC FERMÉ

All cars must be removed from the final Parc Fermé within 60 minutes of the results becoming final and the Stewards have authorized the Parc Fermé to be opened. Beyond this time the Organiser will not be responsible for the cars. Only upon presentation of the Parc Fermé pass issued with the rally materials may a car be removed from the Parc Fermé by the drivers or their representatives.

12.12. PERMITTED EARLY CHECK-IN

Crews are authorized to check-in early without time penalty at:

- TC PF (Parc Fermé - In)
- TC IA (Parc Fermé - In)
- TC 8C (Flexi Service - Out)
- TC 8D (Parc Fermé - In)
- TC I4D (Finish - Holding - In)

12.13. CONTROL PROCEDURE AND TIME CARD HANDLING

12.13.1. General

- a) The following procedures apply and have priority over all the related provisions in the FIA-RRSR as far as they are in conflict. Some of the conflicting article numbers are quoted below, but without claiming to be exhaustive.
- b) Any irregularity or discrepancies regarding the below procedures will result in the application of the FIA-RRSR Art. 19.3.4 and 44.2.12. It is to be noted that, as a principle, the entries recorded on the timing marshals' check sheets shall be decisive.
- c) The complete set of Timecards for the whole rally will be delivered with the rally materials at Administrative Checks. It is imperative for all crews to carry at least all the Timecard sets for a whole day inside the car (cf. for example procedures at regrouping controls).
- d) Competitors are not required to return their time cards at end of section, leg or rally.
- e) In case of retirement, confirmation of a final retirement must be communicated by e-mail, but only by the duly authorized competitor's representative and be addressed to the Clerk of the Course (biuro@rallypoland.pl). Competitors who have retired are not required to hand in their time cards.

12.13.2. Time controls

- a) The check-in procedure begins at the moment as stipulated in the FIA-RRSR Art. 44.2.1.
- b) The check-in time corresponds to the moment at which the co-driver shows their timecard to the marshal through the side window (FIA-RRSR Art. 44.1 and 44.2.4).
- c) The appropriate marshal will then enter the actual time at which the card was shown on the timing tablet and write it on the check sheet (FIA-RRSR Art. 44.2.5).
- d) They will then show the recorded check-in time and, in case of a Time Control followed by a special stage, the provisional special stage start time to the co-driver. The co-driver shall then enter this time on their timecard (FIA-RRSR Art. 44.2.5).

12.13.3. Special stage start

- a) At the start line, the co-driver shows the appropriate marshal the timecard through the side window. The marshal then either confirms this provisional start time or shows a different start time on his check-sheet.
- b) This new time, if any, shall then be recorded as actual start time on the timecard by the co-driver (FIA-RRSR Art. 48.2.3). This actual start time will also be shown on the electronic start count-down display.

12.13.4. Special stage stop point

- a) The appropriate marshal at the stop point will show the finish time (time of the day: hour, minute, second, tenth of a second and thousands for the Power Stage) and the calculated stage time to the crew (co-driver).
- b) The co-driver shall record this time on their timecard.

12.13.5. Regrouping controls (FIA-RRSR Art. 46)

- a) There is no need to hand in the Timecard used for the Section concerned.

- b) For regroupings during a day, the crews shall themselves record their re-start time from the regroup as instructed by the timing marshal on their new timecard for the following Section of that day.
- c) In case of an overnight regroup, the crew shall themselves record their re-start time of the following day on their timecard, following the publication of the start list for the section after the overnight regroup.

12.13.6. Flexi-service

- a) The marshal at the time control Technical Zone – Out / Service – In will keep a check sheet and record the start of the permitted service time.
- b) The marshal at the entrance to the overnight parc fermé will also keep a check sheet to record the time of the car entering the parc fermé.

12.14. OFFICIAL TIME USED DURING THE RALLY

The official time will be UTC/GMT + 2 hours (Summer DTS).

12.15. TESTING

Drivers and/or registered teams who intends to test within a 300 km radius around Rally HQ during the two weeks preceding the rally are obligated to make a request to the Organiser according to the FIA-RRSR – Via ERC Art. 68.4. The Organiser of ORLEN 78th Rally Poland will organise official, extra paid pre-rally test for competitors entered to the rally, on Wednesday, 8 June 2022. Further details will be given in Rally Guide 2.

13. IDENTIFICATION OF OFFICIALS

- | | |
|---------------------------------|--|
| • Stage Commander | - red tabard with text |
| • Safety Officer | - orange tabard with text |
| • Post Chief | - blue tabard with text |
| • Time Control Officer | - blue tabard |
| • Safety Marshal | - orange tabard |
| • Technical Scrutineer | - black tabard |
| • Radio Points Marshals | - yellow tabard with blue radio point symbol |
| • Competitors Relations Officer | - red tabard with text "CRO" |
| • Media Officer | - green tabard |

14. PRIZES

14.1. PRIZE-GIVING CEREMONY

The Prize-giving Ceremony will take place at the Mikolajki Main Square on Sunday, 12 June 2022 at 17:45 (approximately).

I4.2. FIA EUROPEAN RALLY CHAMPIONSHIP

I4.2.1. FIA European Rally Championship for Drivers and Co-Drivers

- 1st, 2nd and 3rd place – 2 cups each

I4.2.2. FIA European Rally Championship for Teams

- 1st place – 1 cup

I4.2.3. FIA ERC3 Championship for Drivers and Co-Drivers

- 1st, 2nd and 3rd place – 2 cups each

I4.2.4. FIA ERC4 Championship for Drivers and Co-Drivers

- 1st, 2nd and 3rd place – 2 cups each

I4.2.5. FIA ERC4 Junior Championship for Drivers

- 1st, 2nd and 3rd place – 2 cups each (for Driver and Co-Driver)

I4.3. SPECIAL PRIZES

A list of Special Prizes will be published on the Official Notice Board before the start of the rally.

I5. FINAL CHECKS AND PROTESTS

I5.1. FINAL CHECKS LOCATION AND TIME

Location: Scrutineering Hall located at Hotel Gołębiewski parking

Date: Sunday, 12 June 2022

Time: 18:15

Immediately after the finish of the rally (Prize-giving Ceremony) cars appointed by the Steward will be taken directly to the Final Checks. After the ceremony crews are obligated to wait for Organiser instructions. Cars subjected to the Final Checks must have one representative of the competitor and relevant number of mechanics present on the Final Checks.

I5.2. PROTEST FEE

The protest deposit is: – 1 000 Euro

If a protest requires the dismantling and re-assembly of a clearly defined part of the car, additional deposit may be specified by the Stewards upon a proposal of the FIA Technical Delegate or Chief Scrutineer. This additional deposit must be paid in cash within one hour to the Organiser, otherwise the protest will be deemed inadmissible.

The expenses incurred by the work and by the transport of the car shall be borne by the claimant if the protest is unfounded, or by the competitor against whom the protest is lodged if it is upheld. If judged partially founded, the additional deposit may be returned in parts. If the protest is unfounded, and the expenses incurred by the protest (Scrutineering, transport, etc.) are higher than the amount of the additional deposit, the difference shall be borne by the protester. Conversely if the expenses are less, the difference shall be returned.

I5.3. APPEAL DEPOSIT

The international appeal deposit (FIA) is: – 3 000 Euro

APPENDIX I – ITINERARY V.2

Sunrise: 4:04

Free Practice / Qualifying							Friday, 10th June 2022	
TC SS	Location	SS distance	Liaison distance	Total distance	Target time	First car due		
TC FP Start of Free Practice							10:30	Qualifying
FREE PRACTICE CLOSSES AT: 12:00								
TC QQS	Service - Out					12:10		
RZ QS	Refuel - Service Park Mikolajki							
TC QS	Baranowo		10,64	10,64	0:17	12:27		
QS	Qualifying Stage - Baranowo	3,46				12:30		
TC PF	Parc ferme - In (early check-in permitted)		11,86	15,32	0:20	12:50		

Sunset: 21:03

Sunrise: 4:04

Leg 1, Section 1							Friday, 10th June 2022	
TC SS	Location	SS distance	Liaison distance	Total distance	Target time	First car due		
Ceremonial Start - Mikolajki, Main Square							17:00	Section 1
0	Service-Out					18:45		
RZ	Refuel - Service Park Mikolajki							
1	Distance to next refuel	(2,50)	(1,85)	(4,35)				
1	Sady		1,00	1,00	0:12	18:57		
SSS-1	Mikolajki Arena 1	2,50				19:00		
1A	Parc ferme - In (early check-in permitted)		0,85	3,35	0:15	19:15		

Sunset: 21:03

Sunrise: 4:04

Leg 1, Sections 2,3							Saturday, 11th June 2022	
TC SS	Location	SS distance	Liaison distance	Total distance	Target time	First car due		
1B	Parc ferme - Out / Service - In					07:30	Section 2	
SERVICE A - Mikolajki, Hotel Golebiewski								0:15
1C	Service - Out					07:45		
RZ	Refuel - Service Park Mikolajki							
2	Distance to next refuel	(28,07)	(106,75)	(134,82)				
2	Piaski		73,80	73,80	1:27	09:12		
SS-2	Krzywe 1	15,20				09:15		
3	Krzyzewko		27,01	42,21	0:52	10:07		
SS-3	Wojnasy 1	12,87				10:10		
RZ	Refuel - Wieliczki (5,94 km after SS-3 Finish)							
3	Distance to next refuel	(24,36)	(90,23)	(114,59)				
4	Sobole		12,17	25,04	0:47	10:57		
SS-4	Wieliczki 1	24,36				11:00		
4A	Regroup & Technical Zone - In		84,00	108,36	1:55	12:55		
4B	Regroup & Technical Zone - Out / Service - In				0:15	13:10		
SERVICE B - Mikolajki, Hotel Golebiewski							0:30	
4C	Service - Out					13:40		
RZ	Refuel - Service Park Mikolajki							
4	Distance to next refuel	(28,07)	(106,75)	(134,82)				
5	Piaski		73,80	73,80	1:27	15:07		
SS-5	Krzywe 2	15,20				15:10		
6	Krzyzewko		27,01	42,21	0:52	16:02		
SS-6	Wojnasy 2	12,87				16:05		
RZ	Refuel - Wieliczki (5,94 km after SS-6 Finish)							
5	Distance to next refuel	(26,86)	(91,07)	(117,93)				
7	Sobole		12,17	25,04	0:47	16:52		
SS-7	Wieliczki 2	24,36				16:55		
8	Sady		83,34	107,70	1:55	18:50		
SSS-8	Mikolajki Arena 2	2,50				19:00		
8A	Parc ferme & Technical Zone - In		0,85	3,35	0:15	19:15		
8B	Parc ferme & Technical Zone - Out / Flexi Service - In				min. 0:10			
FLEXI SERVICE C - Mikolajki, Hotel Golebiewski							0:45	
8C	Flexi service - Out (early check-in permitted)							
8D	Parc ferme - In (early check-in permitted)		0,65	0,65	0:05			
<i>All cars must be returned to Parc Ferme no later than</i>							23:30	
Leg 1 totals		109,86	396,65	506,51				

Sunset 21:04

Sunrise: 4:03

Leg 2, Sections 4,5,6							Sunday, 12th June 2022	
TC SS	Location	SS distance	Liaison distance	Total distance	Target time	First car due		
8E	Parc ferme - Out / Service - In					07:50		
SERVICE D - Mikolajki, Hotel Golebiewski		(0,00)	(0,65)	(0,65)	0:15			
8F	Service - Out					08:05		
RZ 6	Refuel - Service Park Mikolajki							
	Distance to next refuel	(27,95)	(106,00)	(133,95)				
9	Sady		0,57	0,57	0:12	08:17		
SS-9	Mikolajki MAX 1	9,34				08:20		
10	Pietrasze		64,97	74,31	1:22	09:42		
SS-10	Swietajno 1	18,61				09:45		
RZ 7	Refuel - Milki (40,46 km after SS-10 Finish)							
	Distance to next refuel	(11,17)	(26,81)	(37,98)				
11	Marcinowa Wola		48,50	67,11	1:15	11:00		
SS-11	Milki 1	11,17				11:08		
11A	Regroup & Technical Zone - In		18,77	29,94	0:37	11:45		
11B	Regroup & Technical Zone - Out / Service In				0:15	12:00		
SERVICE E - Mikolajki, Hotel Golebiewski		(39,12)	(132,81)	(171,93)	0:30			
11C	Service - Out					12:30		
RZ 8	Refuel - Service Park Mikolajki							
	Distance to next refuel	(27,95)	(106,02)	(133,97)				
12	Sady		0,57	0,57	0:12	12:42		
SS-12	Mikolajki MAX 2	9,34				12:45		
13	Pietrasze		64,97	74,31	1:22	14:07		
SS-13	Swietajno 2	18,61				14:10		
13A	Regroup & Technical Zone - In		40,48	59,09	1:02	15:12		
13B	Regroup & Technical Zone - Out				0:40	15:52		
RZ 9	Refuel - Milki							
	Distance to next refuel	(11,17)	(28,75)	(39,92)				
14	Marcinowa Wola		7,94	7,94	0:13	16:05		
SS-14	Milki 2 (Power Stage)	11,17				16:08		
14A	Technical Zone - In		18,77	29,94	0:37	16:45		
14B	Technical Zone - Out / Service In				0:10	16:55		
SERVICE F - Mikolajki, Hotel Golebiewski		(39,12)	(92,25)	(131,37)	0:10			
14C	Service - Out					17:05		
14D	Finish - Holding - In (early check-in permitted)		2,04	2,04	0:10	17:15		
	Ceremonial Finish - Mikolajki, Main Square					17:45		
Leg 2 totals		78,24	267,58	345,82				

Sunset 21:04



Totals of the Rally				
	SS	Liaison	Total	%
LEG 1 (Sections 1,2,3)	109,86	396,65	506,51	21,7%
LEG 2 (Sections 4,5,6)	78,24	267,58	345,82	22,6%
TOTALS - 14 SSs	188,10	664,23	852,33	22,1%

APPENDIX 2 - RECONNAISSANCE SCHEDULE

DAY 1	
Thursday, 9 June 2022	08:00 - 20:15
SS 2/5 Krzywe	08:00 - 10:15
SS 3/6 Wojnasy	09:30 - 12:00
SS 4/7 Wieliczki	11:00 - 14:00
SS 10/13 Swietajno	13:45 - 16:30
SS 11/14 Milki	16:15 - 18:45
SSS 1/8 Mikołajki Arena	17:45 - 19:45
QS/Shakedown Baranowo	18:15 - 20:15

DAY 2	
Friday, 10 June 2022	08:00 - 09:45
SS 9/12 Mikołajki MAX	08:00 - 09:45

APPENDIX 3 - NAMES AND PHOTOGRAPHS OF CROS AND THEIR SCHEDULES

	
MAGDALENA LEWANDOWSKA	MAREK KISIEL
English	Polish
m.lewandowska@rallypoland.pl	marek.kisiel@pzm.pl
+48 781 996 259	+48 723 302 302

Date	Schedule	Place
Thursday, 9 June 2022	12:00 - 22:00	Rally HQ
Friday, 10 June 2022	08:00 - 10:15 10:30 - 12:00 12:30 - /* 14:30 - 15:30 16:00 - /* 19:00 - /*	Rally HQ Free Practice Parc Fermé /* last Competitor Rally HQ Mikolajki Main Square /* last Competitor Parc Fermé /* last Competitor
Saturday, 11 June 2022	07:15 - /* 12:45 - /* 19:00 - /*	Parc Fermé /* last Competitor Technical zone /* last Competitor Technical zone /* last Competitor
Sunday, 12 June 2022	07:30 - /* 11:30 - /* 15:00 - 17:30 18:15 - 19:15 19:30 - 21:00	Parc Fermé /* last Competitor Technical zone /* last Competitor Technical zone Parc Fermé Rally HQ

APPENDIX 4 - COMPETITION NUMBERS AND ADVERTISING

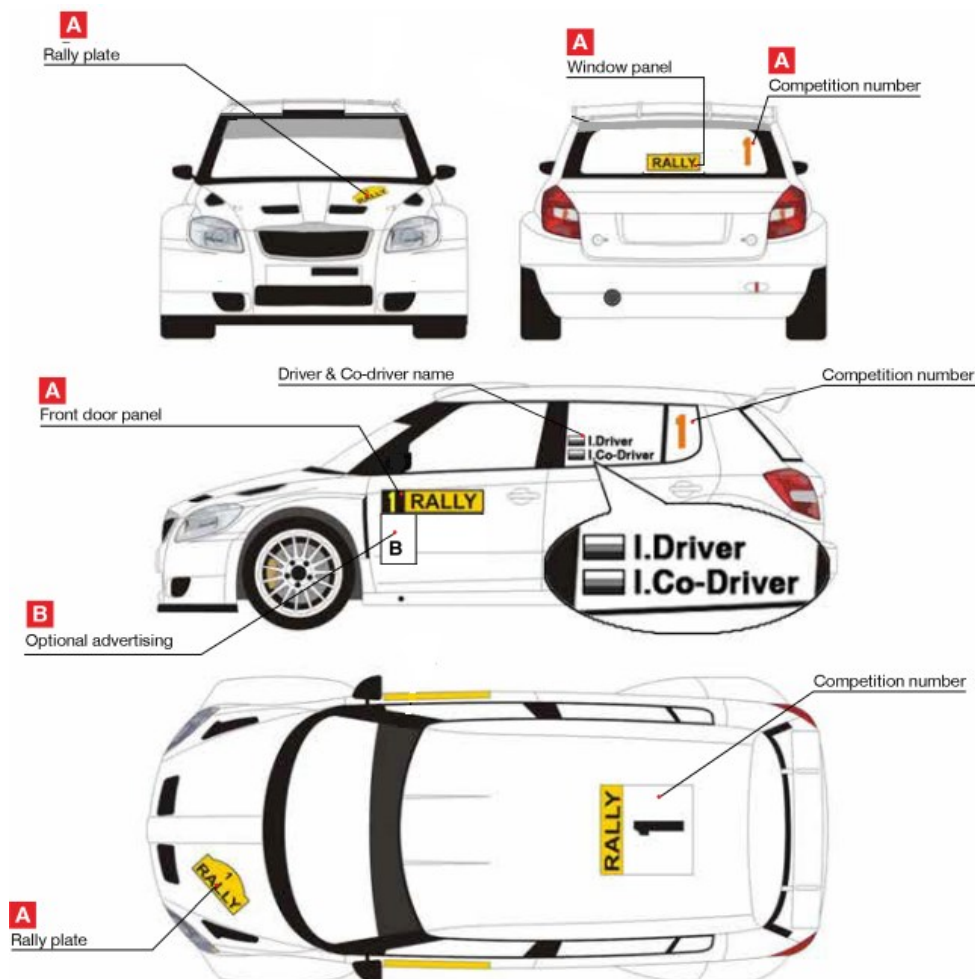

The Organiser will provide each crew with (A):

- One plate fitting into a rectangle (43cm x 21,5cm) which include the competitor number.
- One rear window plate (30cm x 10cm). Must be positioned at the bottom in the centre of the rear window, containing fluorescent orange 14cm high competitor number on a clear background.
- Two front door panels (67cm x 17cm). Each panel shall be placed horizontally at the leading of each front door with the number (in yellow) at the front (in both sides). The top of the plate shall be between 7cm and 10cm below the bottom window line.
- One roof panel with the top towards the front of the car (50cm x 52cm).
- Two numbers in orange (20cm high). Must appear on the rear side window on the both sides of the car adjacent to the crew's names – flags.

All of the above stickers are mandatory for all competitors.

Optional advertising (B):

Below the two front door panel the Organiser reserve an area of a panel measuring 23cm in length an 35cm in high for the Organiser's sponsors.

ERC compulsory advertising:

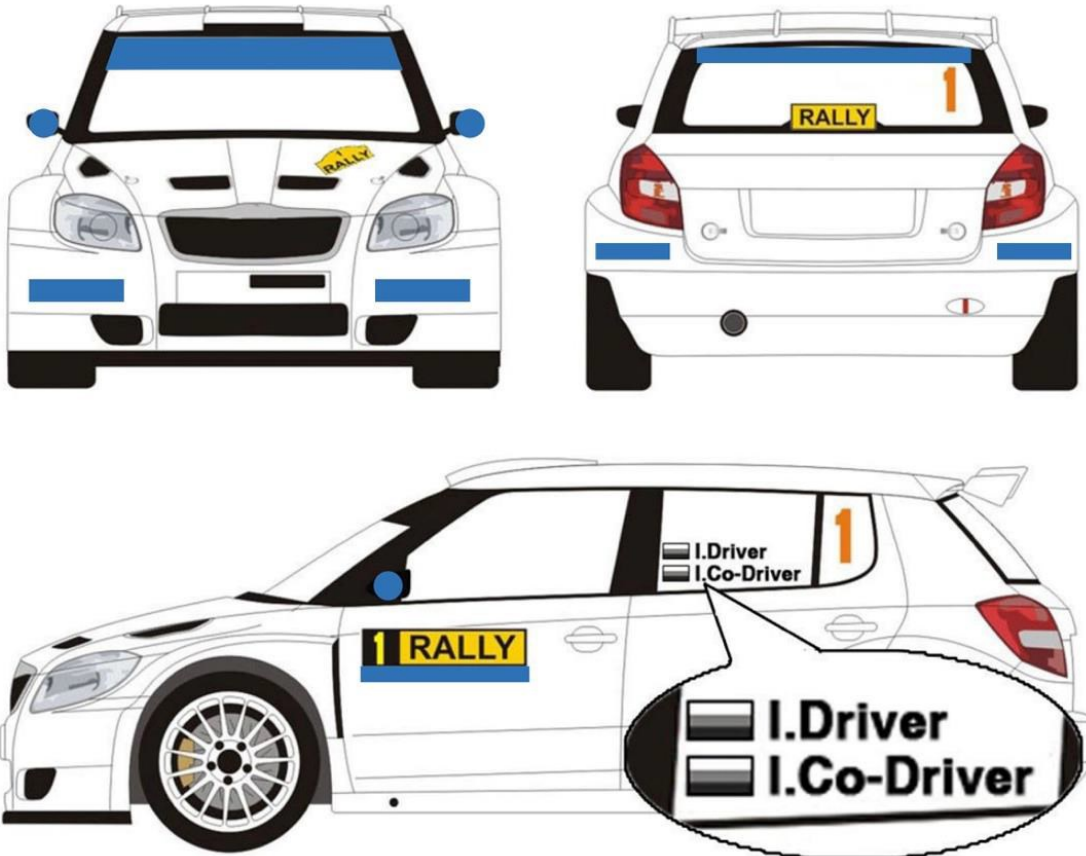

A 15cm strip on the front windscreen of each rally car, including 0 cars



2 side mirror stickers on each rally car



ERC strip below the rally plate on each door of the competing car



2 strips on both front and rear bumpers for tyre supplier



A 8cm strip on the rear windscreen (top) of each rally car

APPENDIX 5 - EXTRACTS FROM FIA APPENDIX L RELATING TO OVERALLS, HELMETS AND ANY OTHER SAFETY REQUIREMENTS

All competitors are reminded of Appendix L of the FIA International Sporting Code, in particular its Chapter III - Drivers' Equipment.

Helmets (Appendix L, Chapter III, Art. 1)

All crews must wear crash helmets homologated to one of the following FIA standards:

- 8858-2002 or 8858-2010 (Technical List N°41),
- 8859 (Technical List N°49),
- 8860-2010 (Technical List N°33), or
- 8860-2018 or 8860-2018-ABP (Technical List N°69).

Frontal Head Restraint (FHR, Appendix L, Chapter III, Art. 3)

All crews must use FIA approved FHR systems homologated to FIA standard 8858.

Approved FHRs, anchorages and tethers are listed in Technical List N° 29.

See also helmet compatibility chart in Appendix L, Chapter III, Art. 3.3.

Flame-resistant clothing (Appendix L, Chapter III, Art. 2)

All drivers and co-drivers must wear overalls as well as gloves (optional for co-drivers), long underwear, a balaclava, socks and shoes homologated to the FIA 8856-2000 standard (Technical List N°27) or 8856-2018 (Technical List N° 74). Please pay special attention to the prescriptions of Art. 2 concerning embroidery and printing on flame-resistant clothing (manufacturer certificates etc.) **as well as concerning the correct wearing of the clothing elements!** See also Regional Rally Sporting Regulations, Article 53.1.

Biometric Devices (Appendix L, Chapter III, Art. 2.1)

Drivers may wear a device to collect biometric data during racing.

- If the biometric device is integrated into a protective garment homologated to FIA Standard 8856, the garment shall be homologated to FIA Standards 8856 and 8868-2018.
- If the biometric device is a stand-alone device, then the device must be homologated to FIA Standard 8868-2018 only. This device must be worn in addition to the garment homologated to FIA Standard 8856.

Wearing of jewellery (Appendix L, Chapter III, Art. 5)

The wearing of jewellery in the form of body piercing or metal neck chains is prohibited during the competition and may therefore be checked before the start.

RELATED LINKS:

FIA International Sporting Code and appendices:

<https://www.fia.com/regulation/category/123>

FIA Technical Lists:

<https://www.fia.com/regulation/category/761>

APPENDIX 6 - SAS FITTING KIT MANUAL - RALLY CAR

This manual is provided as a guide for the installation of the SAS Tracking System Kit, for competition vehicles only. Care should be taken when considering the location of components with regard to electrical cabling and fire suppression systems already installed in the vehicle. Please check always that the components of your kit are as requested.

I. Tracking Unit Kit Components & Steps

The Tracking System Kit includes:

- SAS Tracking Installation and Fitting Kit Instruction Sheet;
- 3-in-1 antenna with leads;
- Internal radio antenna with lead;
- 6 - 24v wiring loom with plug;
- Mount, to be bolted to tunnel;
- Adjustable mount connector/knuckle.



(Contents may differ slightly to image shown)

SAS tracking system fitment steps:

1. Mount SAS tracker;
2. Fit external & internal antennas, running leads to the SAS tracker;
3. Fit wiring loom, ensuring that a solid 9 to 28 volts is supplied;
4. Connect all antenna connections, make sure they are tight using an 8mm spanner;
5. Apply power.

2. Power Supply

SAS tracking system requires a reliable power supply from 9 to 28 volts DC. We recommend a 5 amp (Max) blade type or similar quality fuse is used at the battery supply end of the SAS tracking system power lead.

Zero volts or battery negative can be picked up at any suitable earthing point providing the isolation switch does not switch the negative side of the battery.

The SAS tracking system unit has an internal battery that is kept charged via the car's power supply. It acts as a reserve supply to power the unit in the case of an accident where a car's power supply is interrupted (e.g. car battery smashed or dislodged).

Note: The tracking device should only be powered once it is placed in its final position in the vehicle; this ensures accelerometers are calibrated correctly.

3. Connection Diagram

The 6-24v wiring loom, includes five wires. The white blue and grey wires must be stagger cut and heatshrunk or taped back so they cannot short to ground or to each other. Red and black are used as follows:

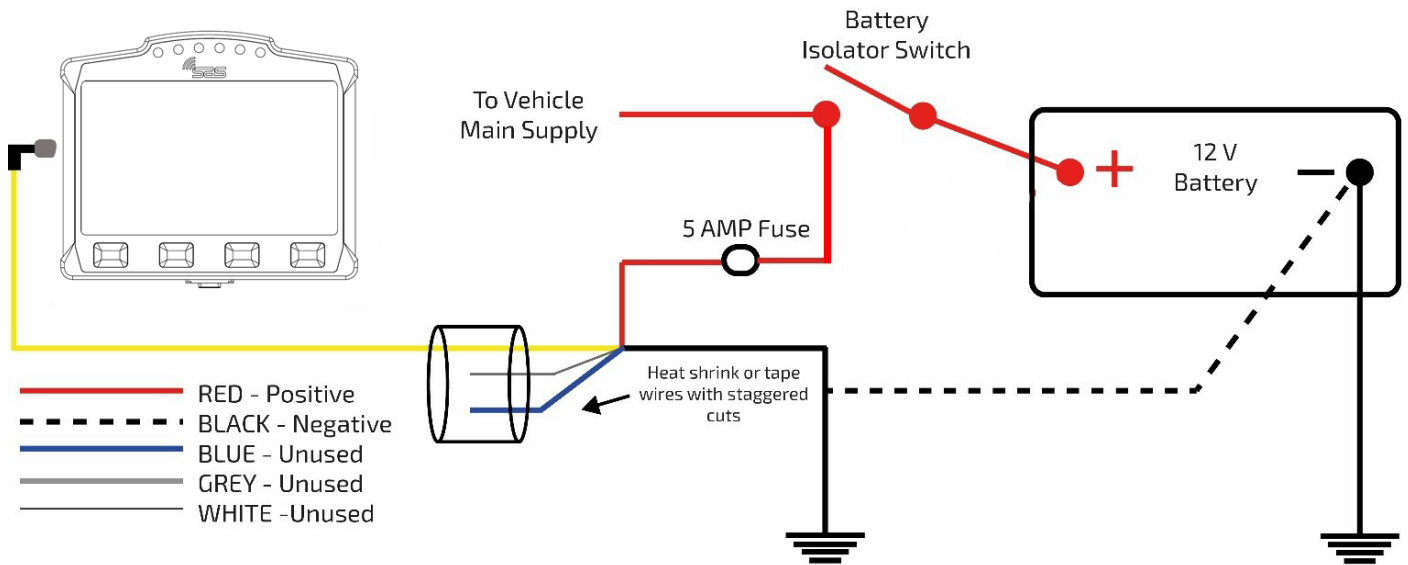

RALLYSAFE 12V WIRING DIAGRAM

During installation, the wiring loom should be routed away from the engine compartment, Ignition or Alternator wiring.

300 mm of Power Supply Wiring Loom is required to be available for connection to the SAS Tracker Unit at the mounted position.

4. Tracking Unit Dimensions

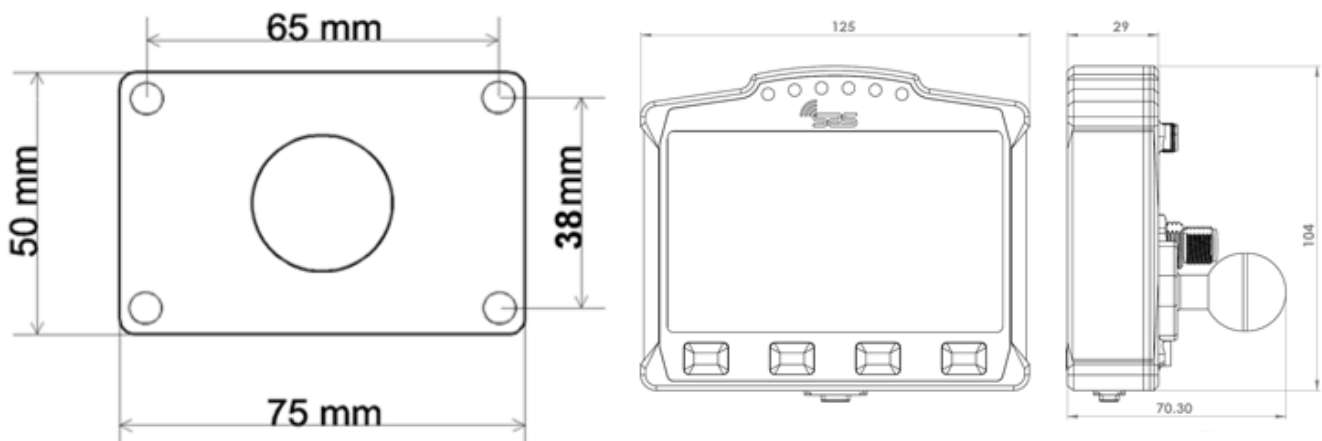

5. Tracking Unit Mounting

The preferred location and mounting for the SAS tracking system unit is a RAM style 50mm x 75mm flatbase with ball, bolted through the tunnel with four M6 Bolts.

It should be in a central, protected location on the central tunnel in front of the seats and both easily visible and accessible by both the driver and co-driver/nav.

Care should be taken when considering the location of the Mounting Point with regard to electrical cabling and fire suppression systems installed in the vehicle.

Photographs of mounting and positioning can be seen in Fig.1 and Fig.2 respectively.

Alternatively, the SAS tracking system unit can be mounted in a central protected location on the vehicle dashboard that is easily visible and accessible by both the driver and co-driver.

Mounting is a Ram style 50mm x 75mm flat base with ball, bolted with four M6 bolts through the dashboard and a compulsory 3mm backing plate measuring no less than 145mm x 120mm



Figure 1. 25mm rubber ball securely attached to the tunnel



Figure 2. The WRC tracking unit mounted onto the 25mm rubber ball mount and connected through the RallySafe connector

6. Antenna Installation

All leads on both external and internal antennas must run on the inside of all roll cage bars. This is to stop cable crushing on impact.

Antenna must not be mounted within 200 mm of any high frequency antenna's or cabling

The preferred route is to go down from the antenna, underneath the closest part of the roll cage (roof cross or main hoop), follow that along to the roof hoop, then go down the inside A pillar to the unit. Please allow 200mm clearance of high frequency antenna or cabling

Any excess cable must be run so that the cable is not bent any tighter than a 100mm radius. We recommend running it across the underside of the dash and back (do not coil in tight loops).

Cables must be tied neatly along the whole installation all the way to the unit so they can't be accidentally caught or dislodged.

All this will be checked at scrutineering and you may be required to fix it before your car can pass.

Note: All antenna connections need to be firmly tightened with an 8mm spanner.

6.1. External Antenna

The antenna is mounted through a 12mm hole in a central location on the ROOF of the vehicle, rear of the main roll bar hoop, allowing the cabling to pass through the roof and follow the cage bars back to the unit location. The antenna is a fully watertight unit, which seals against the roof surface.



Antenna leads are connected as follows (There may be variations with the type and number of leads).

1. The 2 WiFi leads, colour-coded **Blue**, is connected to the terminal labelled "WiFi" on the SAS unit (Right Hand Thread). Terminals are located of the rear of the unit and/or colour-coded Blue.
2. The Satellite Communication antenna lead is connected to the centre or rear terminal labelled "IRI" (Left Hand Thread). It may also be colour-coded **Yellow** (this may be not marked on the 2-in-1 antenna).
3. The GPS antenna lead labelled "GPS", is connected to the terminal labelled "GPS" on the SAS unit (Right Hand Thread). Terminals may be on the side or rear of the unit and/or colour-coded **Green**.
4. GSM, has a small stick antenna supplied with the SAS unit, and is connected to corresponding terminal labelled "GSM" on the SAS unit (Left Hand Thread). The terminal is located on the rear of the unit and/or colour-coded **Red**.

6.2. Internal Antenna

The Internal Antenna should be placed on the inside of the ROOF in a clear uncluttered area, with a 200mm radius clear of any bar work or solid metal object. The internal antenna has a magnetic base with double- sided tape for adhesion. The cable is then run to the SAS unit. Please keep cable on the inner side of the rollcage pipework so as not to be crushed in the event of an accident.

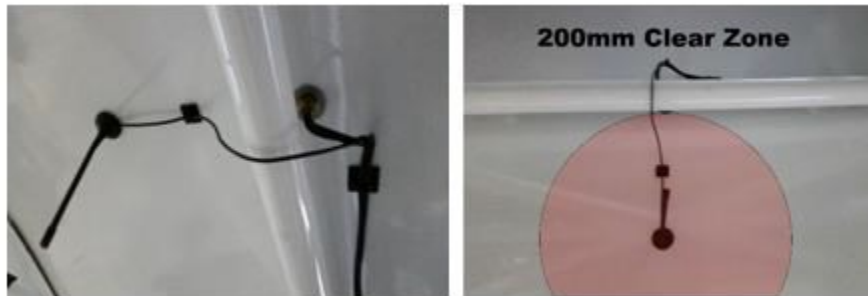

Figure 3. The internal antenna must be at least 200mm away from any roll cage components

7. Contact Us

For assistance, please contact the RallySafe Support Team by emailing: support@rallysafe.com.au

****Product Disclaimer****

"This manual, the specifications, and the material contained in it, as released by Status Awareness Systems and RallySafe, is for the purpose of information only. Due to continuous ongoing development, information and specifications may change at any time without notice. SAS, and the companies that have contributed to it, shall not be liable for any use of the manual or information supplied.

The material contained in this manual is protected by copyright and other types of Intellectual Property Rights. The commercial exploitation of the material contained in this specification requires a license to such Intellectual Property Rights.

This manual may be utilised or reproduced without any modification, in any form or by any means, for informational purposes only. For any other purpose, no part of the specification may be utilised or reproduced, in any form or by any means, without permission in writing from SAS.

The word RallySafe and the RallySafe logo are registered trademarks".



POLSKI
ZWIĄZEK
MOTOROWY



ORLEN



RMF MAXXX



motorsport.com

WP SportoweFakty



bluechem 
GROUP



MRF TYRES

