



RALLY SAFETY SYSTEM

SELF - INSTALLATION MANUAL

FOLLOW THE INFORMATION BELOW

TO INSTALL THE SYSTEM BEFORE GOING TO SCRUTINEERING

Version released on 18.04.2022

STEP 1 – GET FAMILIAR WITH THE SYSTEM COMPONENTS



NOTE: on CARS and TRUCKS, the organization will provide additional extension cable to place the radio antenna on a better position.

- **IMPORTANT! NO CUTTING OF CABLES, MODIFICATION OF CONNECTORS OR OTHER INTERFERENCE IN THE SYSTEM COMPONENTS IS ALLOWED! ANY DAMAGE TO THE EQUIPMENT MUST BE PAID ACCORDING TO THE SUPPLIER'S PART LIST!**

STEP 2 – PREPARE POSITIVE AND NEGATIVE CABLE FROM THE BATTERY TO THE DASH BOARD (SSV, CARS, and TRUCKS) OR THE HANDLE BAR (ENDURO/ATV) AND INSTALL INSULATED TERMINAL CONNECTORS (SUPPLIED BY THE ORGANIZATION)

- **IMPORTANT! THE BATTERY MASTER CUT-OFF (KILL) SWITCH MUST NOT DISCONNECT THE POWER SUPPLY FOR THE RALLY SAFETY SYSTEM.**
- It is the responsibility of the competitors alone to provide, **DIRECT POWER SUPPLY** from the vehicle's battery according to the drawings provided.
- The power cables **MUST** be "flexible" (multi wire), insulated cables – 2 x **min 0.75** to 1.25 mm² (preferably with RED and BLACK insulation color).
- The connection **MUST** have an **IN-LINE FUSE** - "BLADE TYPE" of 5A.

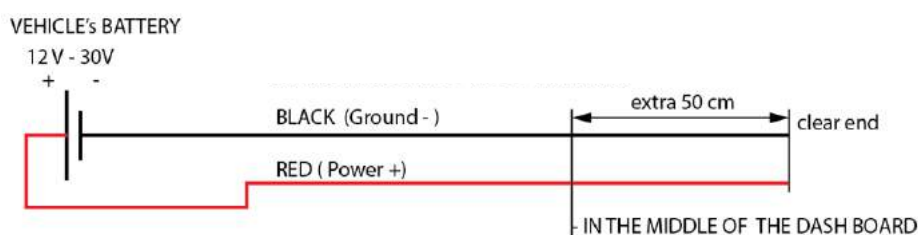

FEMALE INSULATED
TERMINAL CONNECTORS

STEP 3 – MOUNTING THE SYSTEM - OVERVIEW

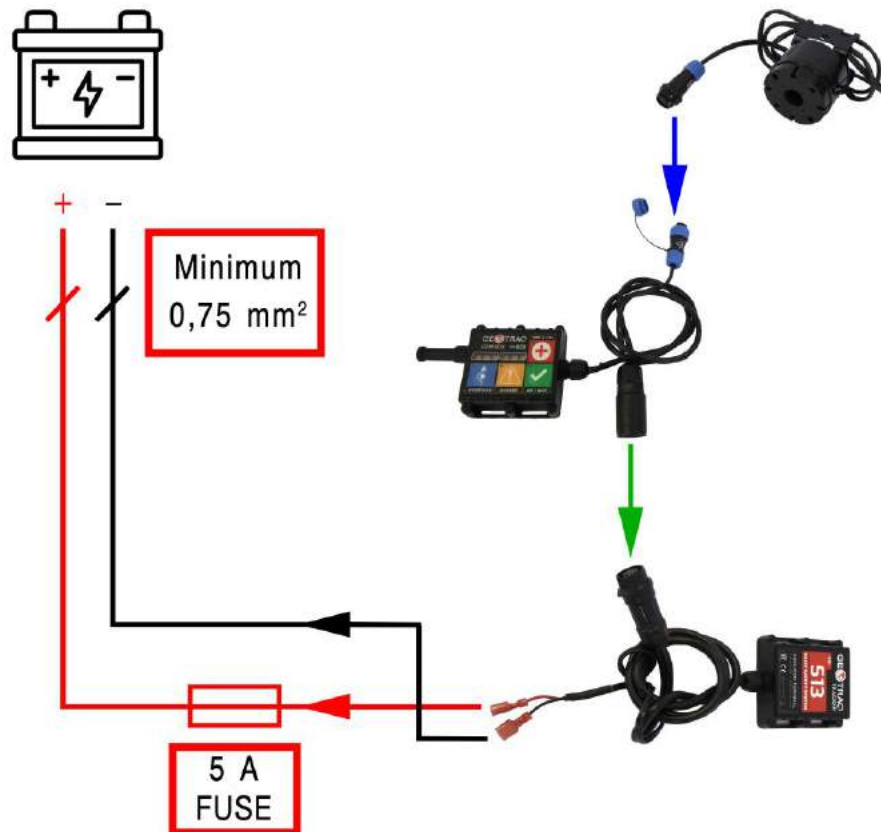

Overview of the system connections.

- You will receive two 6,3 mm female quick plug terminals for the power connection. If you have old terminals, discard them and use the provided new ones.

- **IMPORTANT! USE ONLY THE PROVIDED QUICK PLUG TERMINALS! DO NOT USE YOUR OWN!**
- **IMPORTANT! USE PROPER TOOLS TO CRIMP THEM!**



Proper tools for crimping.

STEP 4 – ORDER FOR CONNECTING THE SYSTEM

During the mounting of the system components you **MUST** follow this order:

- First connect the COM-BOX – TRACKER cable.



Connect the COM-BOX to the TRACKER.

- Second the BUZZER – COM-BOX cable.



Connect the BUZZER to the COM-BOX.

- Last connect the power supply cables.

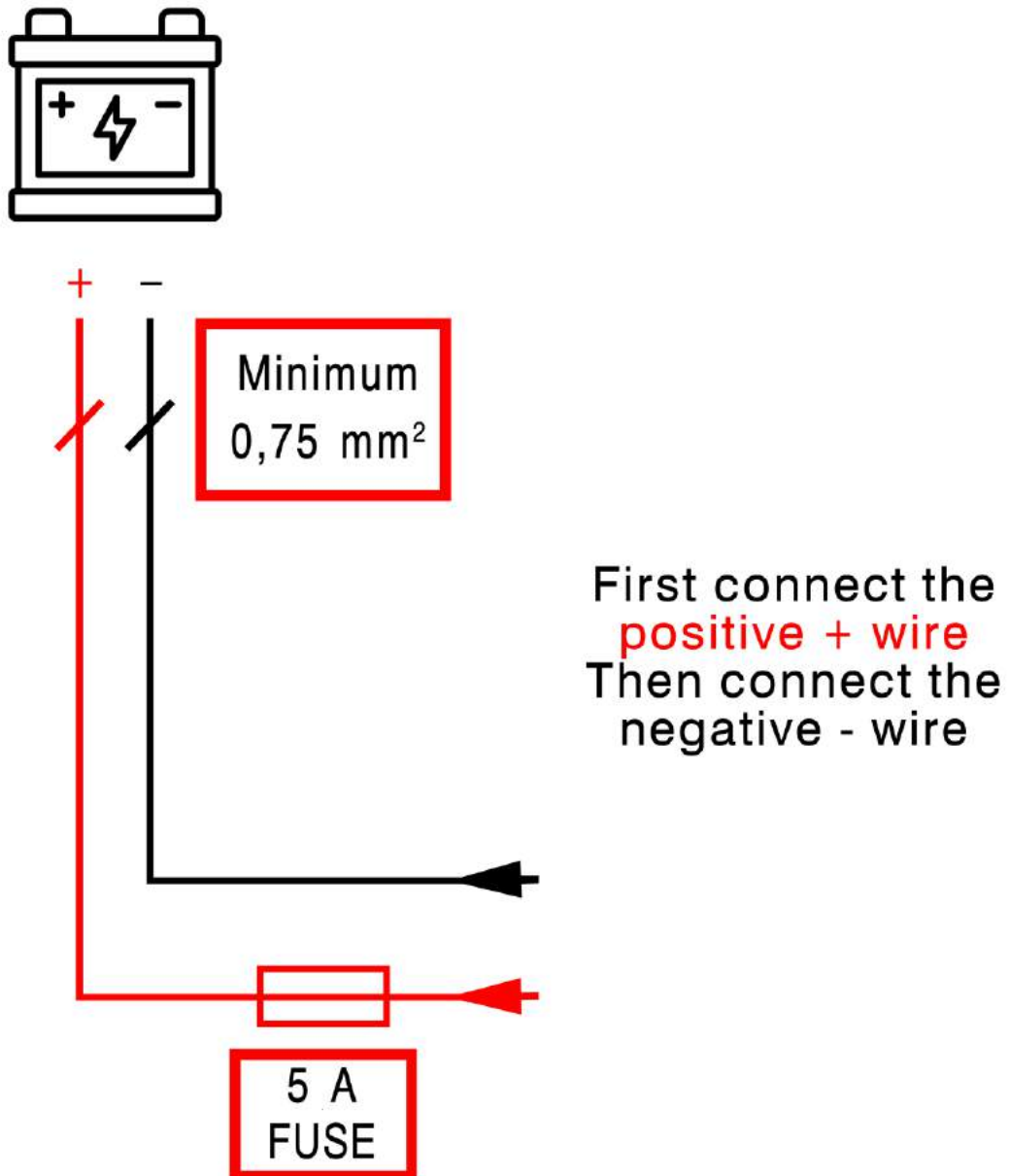

Connecting the power supply after everything else has been connected.

- **IMPORTANT! DO NOT DISCONNECT THE POWER TO THE SYSTEM UNTIL THE END OF THE RALLY!**
- **IMPORTANT! DO NOT OVERUSE CABLE TIES TO SECURE THE CABLES!**

STEP 5 – MOUNT THE GPS TRACKER ON THE PROPER POSITION

- For ENDURO the best position is at the navigation tower or the top end of the suspension forks.
- For ATV the best position is at the navigation tower or the area around the head light
- For SSV, CARS, TRUCKS, the best position is the “A-pillar” of the roll cage, or the horizontal member of the roll cage, with the tracker facing upwards.

- **IMPORTANT! THE GPS TRACKER MUST HAVE VISIBILITY TO THE SKY (NO METAL ON TOP OF THE DEVICE)**
- **IMPORTANT! INSTALLATION IS DONE WITH CABLE TIES THROUGH THE HOLES OF THE BASE OF THE DEVICE**
- **IMPORTANT! POSITION THE DEVICE IN SUCH A WAY THAT NO DIRECT DAMAGE CAN BE DONE!**



Installation of the GPS TRACKER on the suspension fork using cable ties.



Installation of the GPS TRACKER on the navigation tower using cable ties.



Installation of the GPS TRACKER on the railing of ATV using cable ties.



Installation of the GPS TRACKER on the roll cage "A-pillar" of a SSV using cable ties.

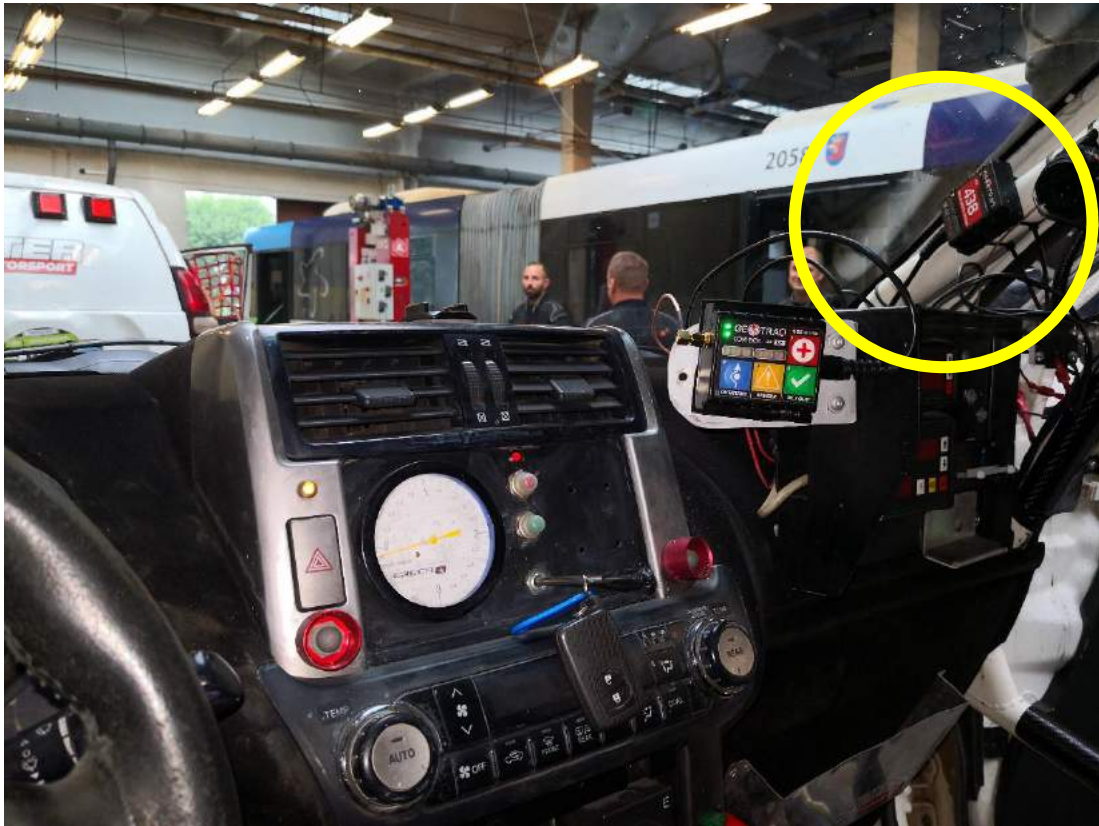

Installation of the GPS TRACKER on the roll cage "A-pillar" of a Car using cable ties.

STEP 6 – MOUNT THE COM BOX MOUNTING BRACKET AND INSERT THE COM-BOX UNIT ON THE PROPER POSITION

- You can bolt the mounting bracket as shown in the graphics bellow, or you can use double-sided tape to stick it to a good surface or use cable ties to fix it to a tube of the roll cage.
- If needed, additional opening can be drilled to fix it on the required position.

- **IMPORTANT! THE COM-BOX MUST BE IN REACH OF THE DRIVER / CO-DRIVER TO OPERATE THE BUTTONS!**
- **IMPORTANT! LEAVE ADDITIONAL SPACE ON THE SIDE OF THE UNIT FOR THE PROPER WORK OF THE ANTENNA / EXTENSION AND SLIDE THE UNIT IN TO THE BRACKET!**

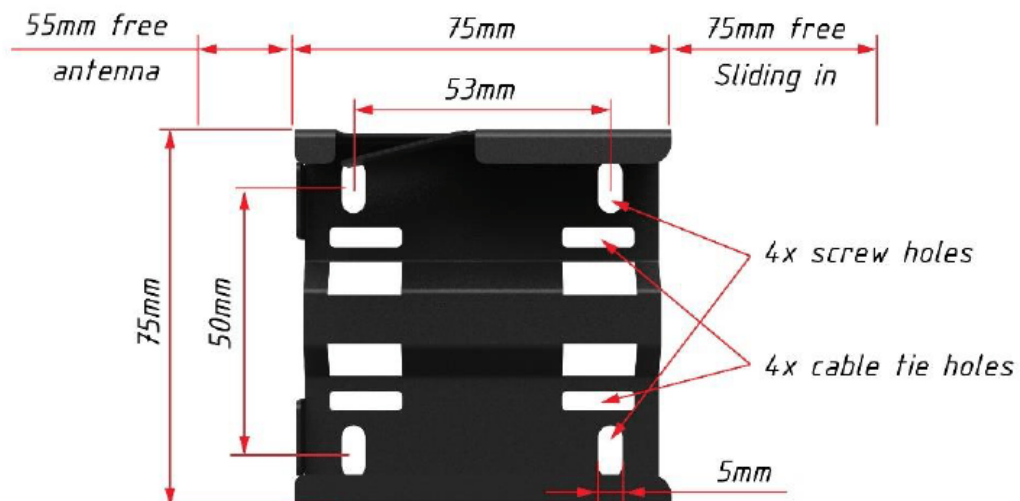



IMPORTANT: No bolt/screw heads or cable/zip ties can protrude over the red line as marked below.

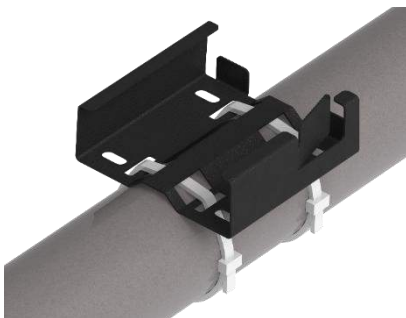
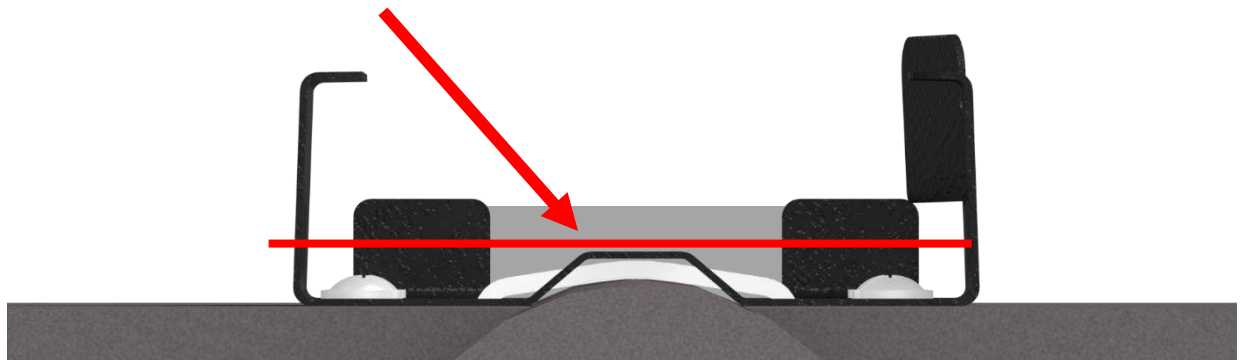

Cable / zip tie fixture

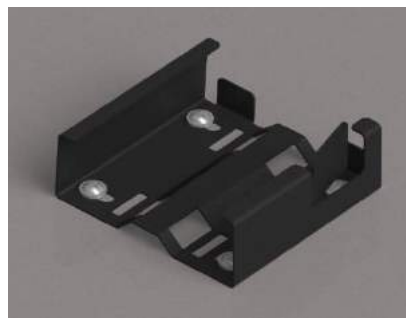

Screw / bolt fixture



Com-Box unit installed in bracket

- When the mounting bracket is securely installed, you can slide-in the Com-Box unit in.



- **IMPORTANT! THE ANTENNA NEEDS ATLEAST 55mm IN ALL SIDES TO WORK PROPERLY! MAKE SURE NOT TO PLACE IT RIGHT NEXT TO METAL PIECES!**



Installation of the Com-Box unit with bracket on the handle bar using cable ties.



Installation of the Com-Box unit with bracket on the handle bar using cable ties.



Installation of the Com-Box unit with bracket on the roll cage using cable ties.



Installation of the Com-Box unit with bracket on the dashboard using bolts.

STEP 7 – MOUNT THE BUZZER ON SUITABLE POSITION

- You can use cable ties to fix it to a tube of the roll cage or similar base.
- **IMPORTANT! FOR CARS AND TRUCKS, THE BUZZER WILL BE SUPPLIED WITH ADDITIONAL RADIO EXTENSION CABLE THAT GOES FROM THE COM-BOX UNIT TO THE BASE OF THE BUZZER MOUNT AND THE ANTENNA WILL BE ATTACHED ON THE BUZZER MOUNT.**



Installation of the Buzzer with bracket on the handle bar using cable ties.



Installation of the Buzzer with bracket on the handle bar using cable ties.



Installation of the Buzzer with bracket on the Roll cage using cable ties.



Installation of the Buzzer with bracket on the Roll cage using cable ties.

STEP 8 – CHECK IF THE INSTALLED ANTENNA IS UNDAMAGED AND MOUNTED.

- **IMPORTANT! DO NOT USE FORCE IF TIGHTENING THE CONNECTOR. TIGHT WITH FINGERS ONLY!**



Installed antenna on the Com-Box unit.





Installed antenna on the Buzzer unit (optional only when using extension cable).

STEP 9 – CHECK THE STATUS OF THE RALLY SAFETY SYSTEM.



- First, make sure the antenna is connected (optional extension cable and antenna)
- Second, check the blue connectors (buzzer)
- Third, check the connection of the black connectors between the GPS Tracker and the Com-Box unit
- Finally check the connection of the 2 power terminals (positive and negative)

- **IMPORTANT! WHEN CONNECTING THE POWER TERMINAL MAKE SURE YOU HAVE THE PROPER POLARITY – RED is POSITIVE, BLACK is NEGATIVE!**
- **IMPORTANT! IF ALL THE COMPONENTS ARE CONNECTED PROPERLY, THE COM-BOX UNIT WILL DISPLAY A “GREEN STATUS” ON THE BATTERY ICON AND “BLUE/GREEN STATUS” on the RADIO ICON**

BATTERY STATUS

-  - EXTERNAL POWER
-  - NO EXTERNAL POWER
-  - (BLINKING) INT. BATTERY EMPTY

RADIO STATUS

-  - RADIO OK
-  - SLEEP MODE, NO RADIO

OVERTAKE FUNCTION

DANGER BEACON



EMERGENCY SOS BEACON

- PRESS AND HOLD UNTIL ACTIVATED

CONFIRM / QUIT BUTTON

STEP 10 – FINAL INSPECTION AT SCRUTINEERING

- Leave the cables in such a way that they can be checked at scrutineering.
- Only after you receive START PERMISSION, you can make the cables as best you want on the vehicle using cable ties. **DO NOT** overuse cable ties!
- **DO NOT** use insulating or any other tape to group the cables.

- **IMPORTANT! DO NOT PUT THE CABLES OF THE SYSTEM IN HIDDEN PLACES (INSIDE THE DASHBOARD OR HARD TO REACH LOCATIONS). THE MARSHALS WILL CHECK ALL THE SYSTEM AND COMPONENTS FOR PROPER INSTALLATION AND OPERATION AT THE SCRUTINEERING AND IF NEEDED THEY WILL REMAKE THE WIRING.**

STEP 11 – WATCH THE VIDEO OF HOW TO USE THE SYSTEM

- On the following link, you can learn how to operate with the Com-Box:

<https://www.youtube.com/watch?v=6hSXuu6DcyE>



STEP 12 – RETURNING THE SYSTEM

When it's time for you to take off the system from your vehicle you **MUST** follow this order:

- First disconnect the negative (-) wire, then disconnect the positive (+) wire from your vehicle female quick connect terminals.
- Second disconnect the COM-BOX - TRACKER cable
- Third disconnect the Buzzer – COM-BOX cable

- **IMPORTANT! WHEN YOU RETURN THE SYSTEM TO THE CHECKOUT STATION, YOUR EQUIPMENT WILL BE CHECKED FOR DEFECTS AND IF SUCH ARE FOUND – YOU WILL BE SANCTIONED WITH YOUR DEPOSIT MONEY.**