

DAILY BRIEFING

Stage 12 ***Bisha–Jeddah***



DREAM.
DARE.
LIVE IT.

INFO STAGE

Stage Distance: 608 KM

- 1st Car at TC 1 (Bivouac) : 05:30 am
- 1st Car at TC 2 : 08:55 am
- 1st Car at SRT 32 : 09:00 am

- SRT32 : 54,55 KM
- SRT33 : 25,12 KM
- CP1 : KM 295,36 **(DAKAR CROSSING)**

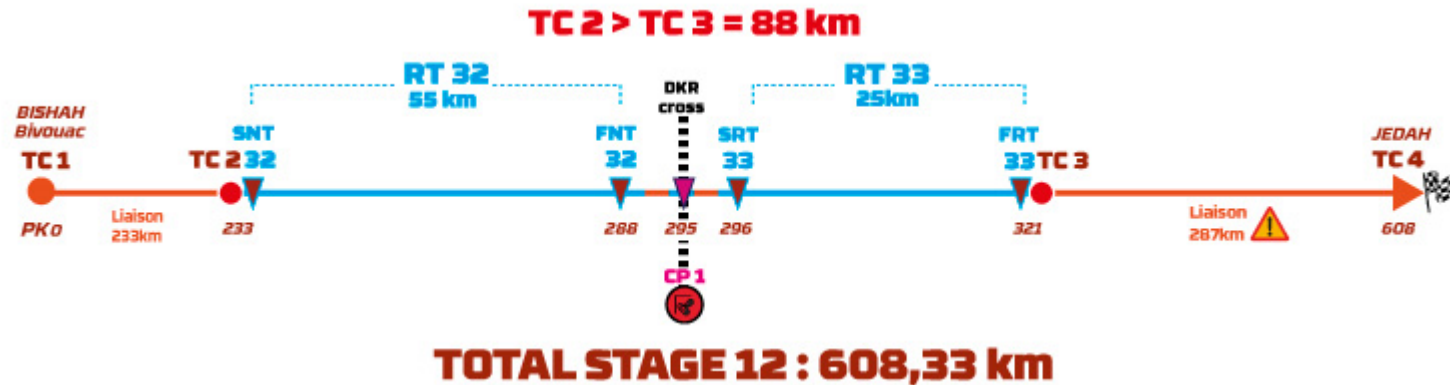

DESCRIPTION

GENERAL INFORMATION:

- Very Long Liaison
- Two last RT ! First one could be tricky.
- Dakar Crossing in Transfert follow Marshalls instruction

DETAILS

- FUEL** : Refueling at the Bivouac. Others fuel station : On Liaison A – 21 – 25 – 88 – 89 – 113 – 178
 On Liaison B – KM: 331 – 332 – 394
- COMPLICATED ROADBOOK BOX** : **Danger !!** : KM 242 – 245 – 246/248 – 259/262 – 265/266 – 295 – 301 – 305/307
SPEED LIMIT ZONE : CP1 Dakar Crossing (accelerate quickly after the FZ30)

294,65		H1: _____
0,43		H2: _____
295,36		H1: _____
0,71		H2: _____

Next 0,10 **Danger 2**

23	DKC ETAPE 12 / BISHA / JEDDAH	Km : 608,33
295,46		H1: _____
0,10		H2: _____
296,50		H1: 50
1,04		H2: 55



DESCRIPTION

- RT32 : First part tricky navigation lot of close distances. Codriver be focus ! Tricky & slow terrain. Second part faster before arrival.
- Transfert with CP1 Dakar Crossing
- RT33 : Shorter RT winding tracks between vegetation. SLOW DOWN QUICKLY after FRT33.
- Commun Arrival at the CH3 with Dakar. Interview area – Media
- Long Liaison B do not lose time on the way. Careful Storm possible !
- At your arrival in Jeddah :
 - 1-Enter the Circuit F1 area for the Dakar Classic Finisher Arch (remove your **Iritrack** after the Arch)
 - 2-Rejoin the Assistance Park close to the Podium (remove your **Tripy** at the Assistance Park Entrance)
 - 3-Rejoin when you decide the Port (Roadbook on Sportity) 14/01: 3:00pm-11:00pm 15/01: 8:00am-7:30pm
 - 4- For the 3 overall be ready close to Podium at 7:30pm for the Official Price Giving Ceremony at night

For your Service cars : 1 – Go to Service Park with the TRIPY (Remove Tripy at the Assistance Park Entrance)
2 – Go to Jeddah Port directly (leave your TRIPY here at Bisha Bivouac Competitor Office) –
Roadbook available on Sportity



DESCRIPTION

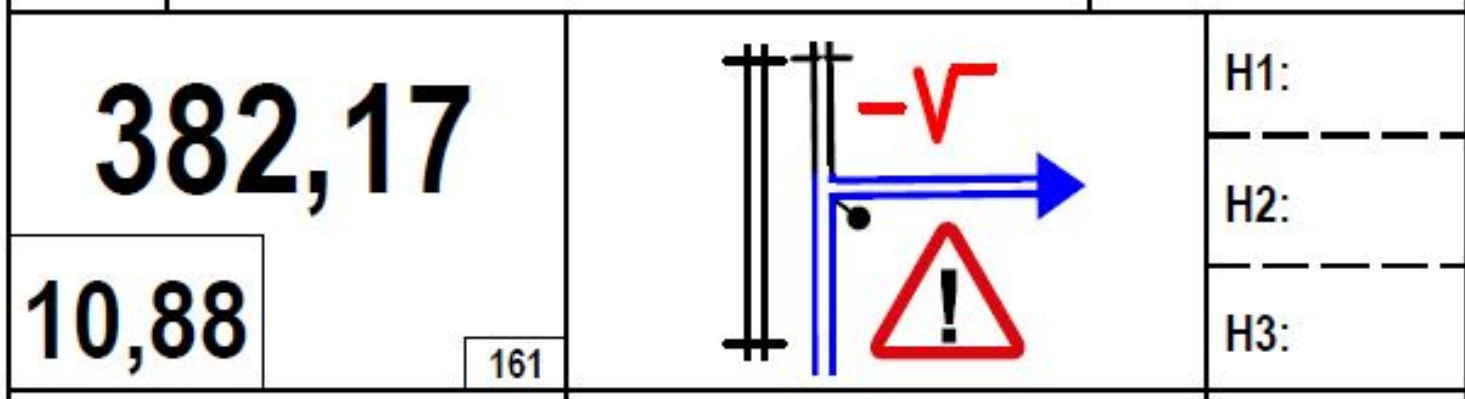

- On Liaison B : KM 382 INVISIBLE ROAD ! TURN RIGHT

***Drive Safe !
LAST ONE !***



***DREAM.
DARE.
LIVE IT.***

DAILY BRIEFING

Etape 12 ***Bisha–Jeddah***



DREAM.
DARE.
LIVE IT.

INFO STAGE

Distance Etape: 608 KM

- 1^{ère} Voiture au CH 1 (Bivouac) : 05:30 am
- 1^{ère} Voiture au CH 2 : 08:55 am
- 1^{ère} Voiture à SRT 32 : 09:00 am

- SRT32 : 54,55 KM
- SRT33 : 25,12 KM
- CP1 : KM 295,36 (**CROISEMENT DAKAR**)

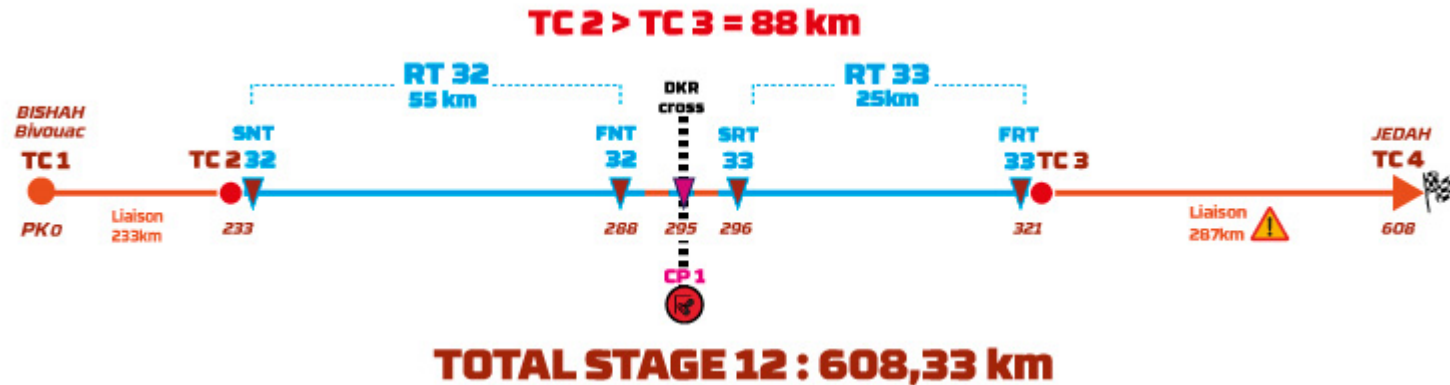

DESCRIPTION

INFORMATIONS GENERALES:

- Longues Liaisons
- Deux dernière RT ! La première peut être compliquée.
- Croisement du Dakar pendant Transfert : suivre instruction des Marshall [priorite au DKR Moderne]

DETAILS

- FUEL** : Refueling au Bivouac. Autres stations : Sur Liaison A – 21 – 25 – 88 – 89 – 113 – 178
 Sur Liaison B – KM: 331 – 332 – 394
- NOTES ROADBOOK DELICATES** : **Danger !!** : KM 242 – 245 – 246/248 – 259/262 – 265/266 – 295 – 301 – 305/307
ZONE VITESSE LIMITEE : CP1 Croisement Dakar (accélérer rapidement après FZ30)

294,65				H1: _____
0,43				220
295,36				H1: _____
0,71				CP1

Next 0,10 **Danger 2**

23	DKC ETAPE 12 / BISHA / JEDDAH	Km : 608,33		
295,46				H1: _____
0,10				STOP
296,50				H1: 50
1,04				211
				H3: 65



DESCRIPTION

- RT32 : Première partie, navigation compliquée, partiels rapprochés. Terrain lent et piégeux. Seconde partie plus rapide avant l'arrivée
- Transfert avec CP1 au croisement avec le Dakar
- RT33 : RT Courte – Pistes sinueuses dans végétation. RALENTIR DES LA FRT33.
- Arrivée Commune au CH3 avec le Dakar. Aire d'interview et média.
- Longue Liaison B ne tardez pas en route. Attention aux orages possibles
- A votre arrivée à Jeddah :
 - 1-Entrez sur le site du Circuit de F1 pour rejoindre l'arche Finisher du Dakar Classic (retirer l'**Iritrack** à l'entrée)
 - 2- Rejoignez le Parc d'Assistance proche du Podium (retirer votre **TRIPY** à l'entrée du Parc Assistance)
 - 3-Rejoignez quand vous le souhaitez le Port (Roadbook sur Sportity) 14/01: 3:00pm-11:00pm 15/01: 8:00am-7:30pm
 - 4-Les 3 premiers du Classement Général (toutes catégories confondues) se présentent proche du Podium à 19h30 pour la cérémonie de remise des prix officiel le soir

Pour les véhicules Assistance: Option1 – Rejoindre Parc Assistance (proche Podium) en utilisant le TRIPY (Retirer le tripy à l'entrée du Parc)

Option2 – Aller directement au Port de Jeddah (laisser vos TRIPY ici à BISHA au service Concurrent) Roadbook disponible sur Sportity



DESCRIPTION

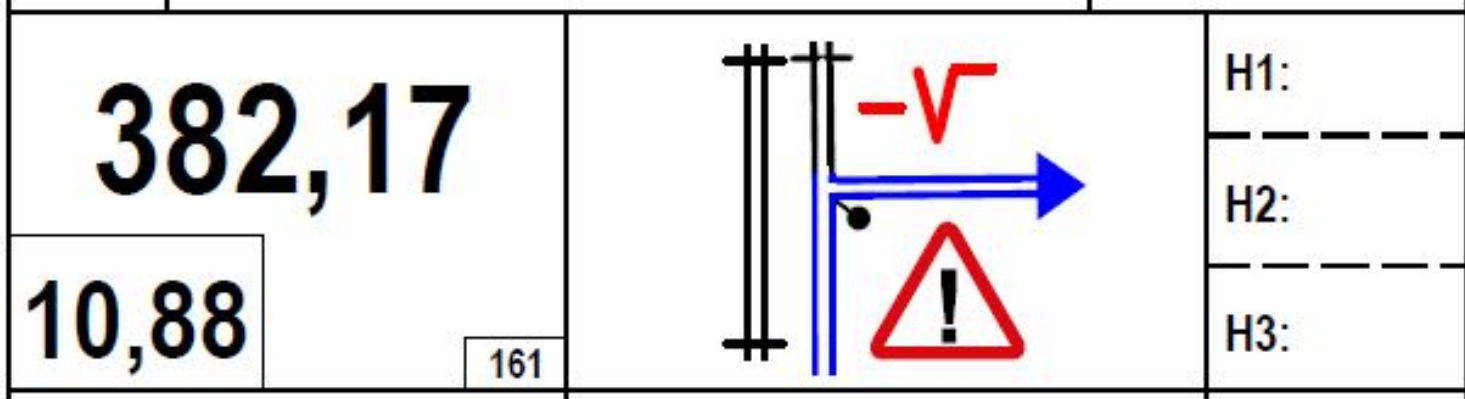

- Sur Liaison B : KM 382 – Route à Droite Invisible

La Der' des Der'!



***DREAM.
DARE.
LIVE IT.***

DAILY BRIEFING

Etapas 12 ***Bisha – Jeddah***



DREAM.
DARE.
LIVE IT.

INFORMACION ETAPA

Total distancia etapa: 608 KM

- 1st Car at TC 1 (Bivouac) : 05:30 am
- 1st Car at TC 2 : 08:55 am
- 1st Car at SRT 32 : 09:00 am

- SRT32 : 54,55 KM
- SRT33 : 25,12 KM
- CP1 : KM 295,36 **(CRUCE CON DKR)**

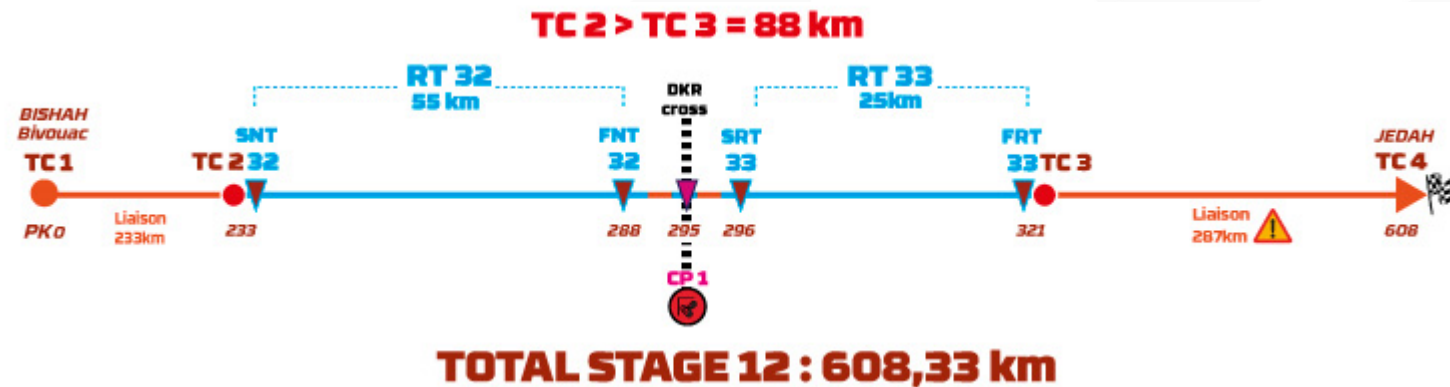

DESCRIPTION

INFORMACIÓN GENERAL:

- Enlaces muy largos (A y B)
- Dos últimas RT, la primera es bastante liante.
- Cruce con el Dakar en zona de transfer, seguir las indicaciones de los Marshals en el CP1 (recordar prioridad para el DKR Moderno)

DETAILS

- FUEL :** Refueling en el Bivouac. Others fuel station : En Liaison A – 21 – 25 – 88 – 89 – 113 – 178
 En Liaison B – KM: 331 – 332 – 394
- NOTAS DE ROAD BOOK:** **Peligros !! :** KM 242 – 245 – 246/248 – 259/262 – 265/266 – 295 – 301 – 305/307
ZONAS DE VELOCIDAD : CP1 Dakar Cruce con el DKR (acelerar rapido después del FZ30)

294,65			H1: _____
0,43			H2: _____
295,36			H1: _____
0,71			H2: _____

Next 0,10 **Danger 2**

23	DKC ETAPE 12 / BISHA / JEDDAH	Km : 608,33	
295,46			H1: _____
0,10			H2: _____
296,50			H1: 50
1,04			H2: 55



- RT32 : primera parte con muchos cruces y parciales muy cortos. Atención copilotos! Parte lenta. Segunda parte más rápida hasta el final
 - Transfer con el cruce del DKR
 - RT33 : RT más corta en pistas sinuosas dentro vegetación. Ralentizar después de FRT33 (Llegada del DKR próxima).
 - Llegada comun en el CH3 con el Dakar. Interview area – Media
 - Enlace B largo y complicado, no perder tiempo, ATENCION posibles tormentas durante el Enlace B
 - A la llegada en Jeddah:
 - 1-Entrar en el circuito de F1 en la zona reservada al DKR Classic para pasar por el Arco de Llegada (devolver el Iritrack a la entrada del circuito)
 - 2-Ir hasta el Paque de Asistencia cerca del Podium (seguir road book papel que se os entregará)(devolver el **Tripy** a la entrada del Parque de Asistencia)
 - 3-Devolver vehiculos en el Puerto cuando terminéis (Roadbook en Sportity) 14/01: 3:00pm-11:00pm 15/01: 8:00am-7:30pm
 - 4-Los 3 finalistas deberan estar presentes para la ceremonia del podium a las 19. 30 en la zona de la CORNICHE
- Para las Asistencias:** 1 – Ir hasta el Service Park siguiendo el Tripy (devolver Tripy a la entrada del Parque Asistencia)
- 2 – Ir hasta el puerto de Jedah directo desde Bishah (devolver el Tripy en el Bivouac de Jedah y seguir Road Book colgado en Sportity)



DESCRIPTION

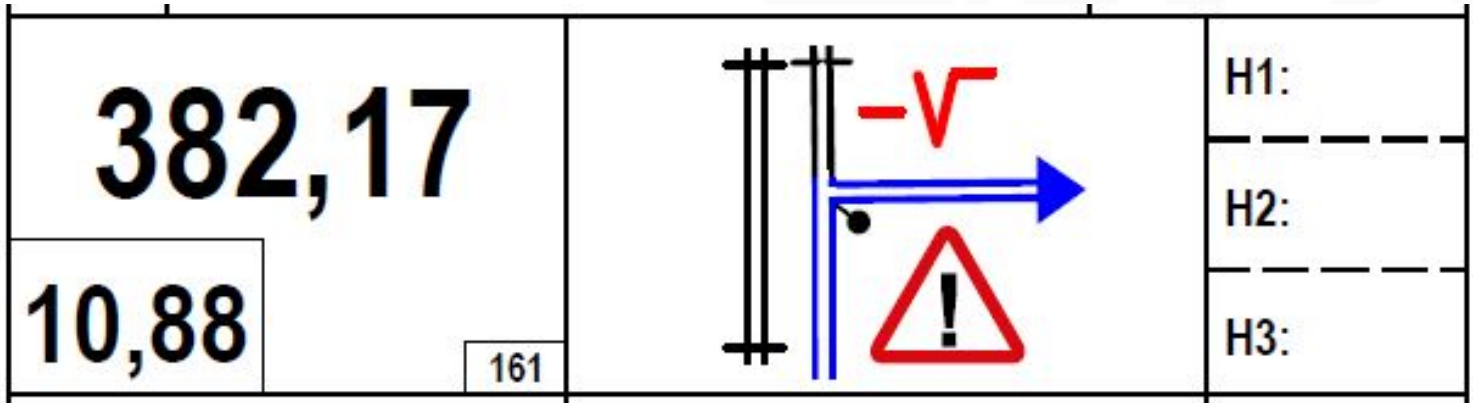

- En Enlace B : KM 382 – Atención Ir a la derecha

***Mucho que perder, poco
que ganar!***



***DREAM.
DARE.
LIVE IT.***