



DAKAR
2022



SAUDI ARABIA









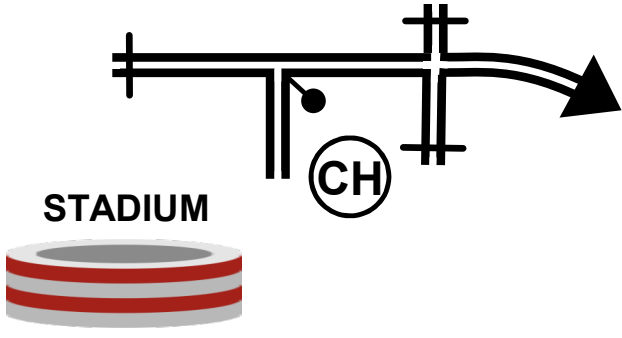

**WEDNESDAY 29TH & THURSDAY 30TH
DECEMBER 2022**

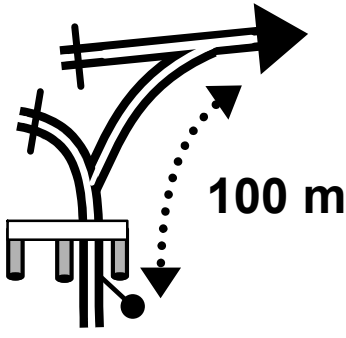
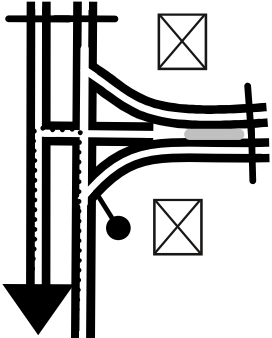
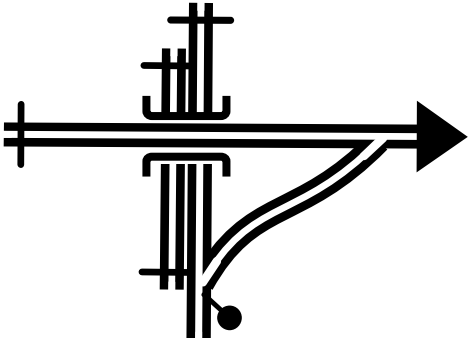
JEDDAH ► JEDDAH

ROADBOOK

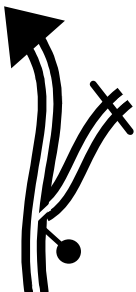
PRIVATE TEST

1	/ PRIVATE TEST / LIAISON A	Km : 54,82
0,00	 <p>STADIUM</p> <p>CH</p>	 CH LIAISON 
0,00		
0,35	 <p>100 m</p>	
0,35		
0,70		"U" TURN
0,35		
1,38		 ASFAM AL MADIMAH  
0,68		
2,99		 ASFAM
1,61		

Next 14,58

2

/ PRIVATE TEST / LIAISON A

Km : 54,82

17,57

14,58

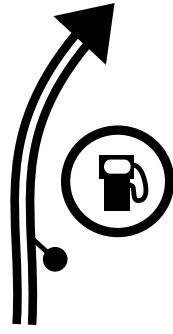

AL DRESS

28,41

10,84

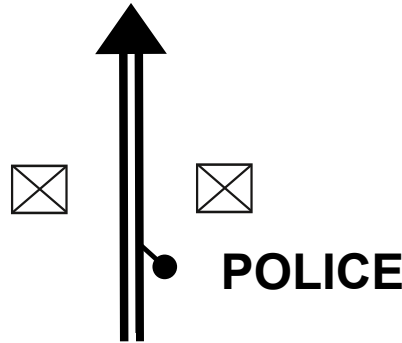

30,29

1,88

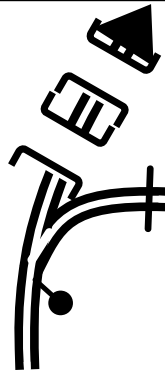

30,86

0,57

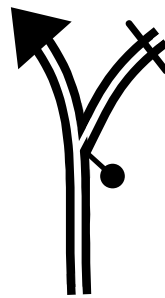

➔
USFAM

31,54

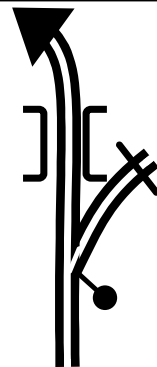

0,68



➔
OSFAM

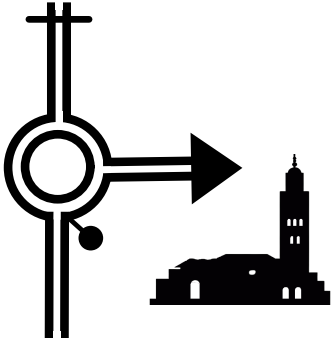

Next 6,72

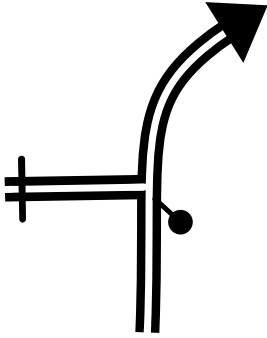
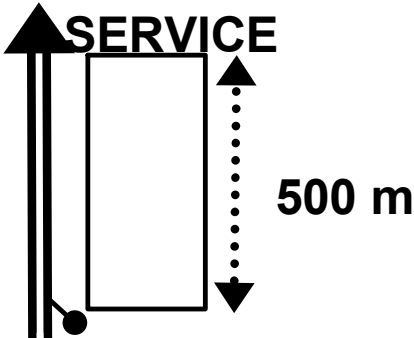
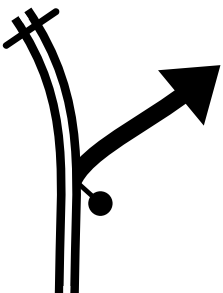
3	/ PRIVATE TEST / LIAISON A	Km : 54,82
<p>38,26</p>		
<p>6,72</p>		
<p>54,34</p>		
<p>8,86</p>		<p>ET à 280m START PRIVATE TEST</p>
<p>0,49</p>		

Next

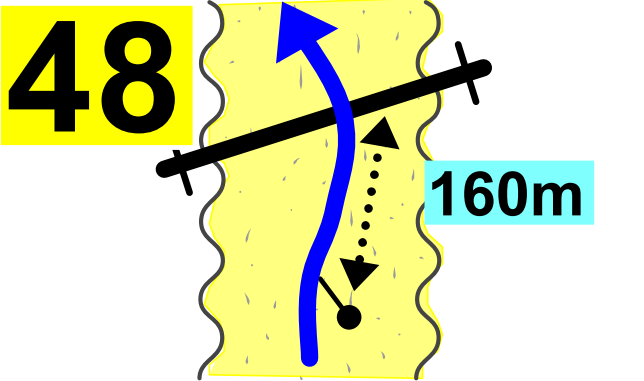
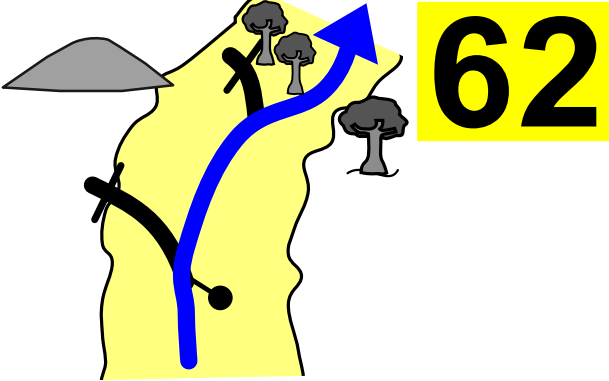
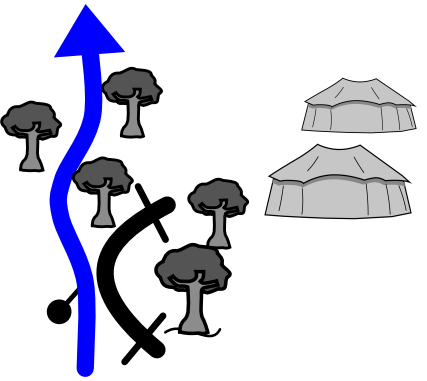
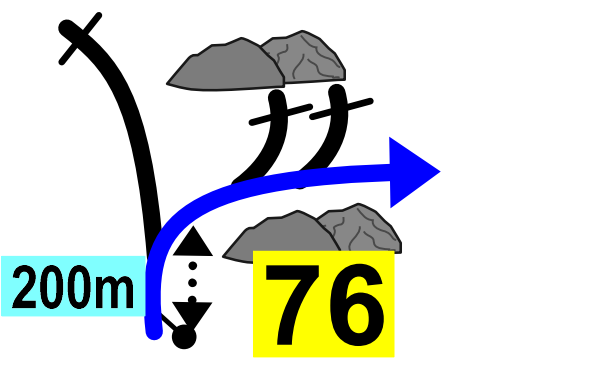
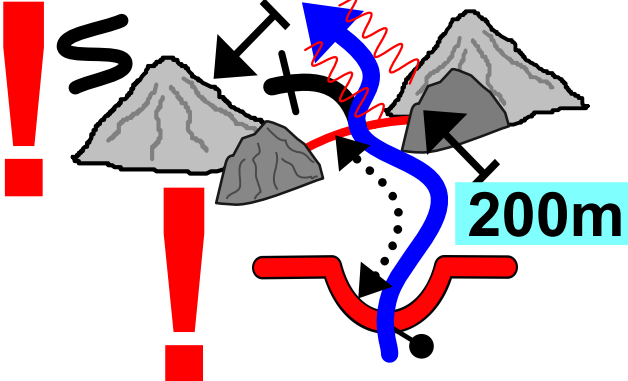
1	/ PRIVATE TEST /	Km : 10,67
0,00		START PRIVATE TEST 5
0,00	S	
0,52		
0,52		
1,56		
1,04	↓	
1,85		ET à 200m 128^A DS CANYON
0,29		
2,27		↗ S EMP
0,42		

Next 0,46

Danger 1

2,73

0,46

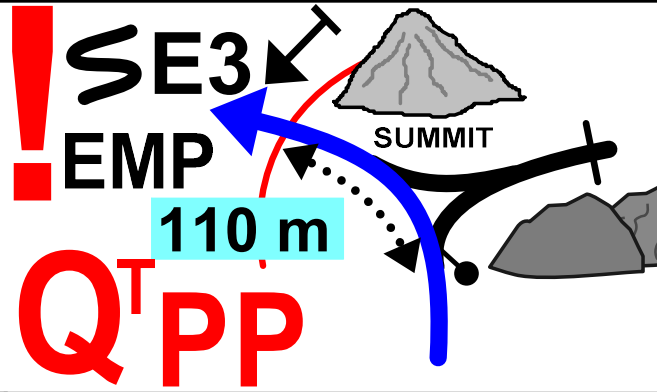

6

3,19

0,46 ↓

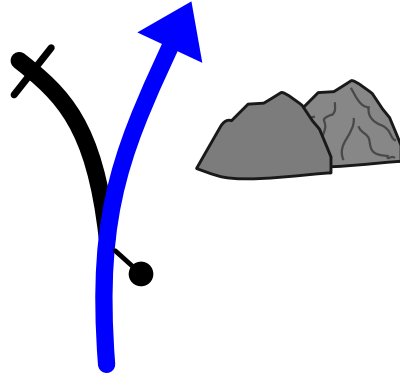

3,33

0,14

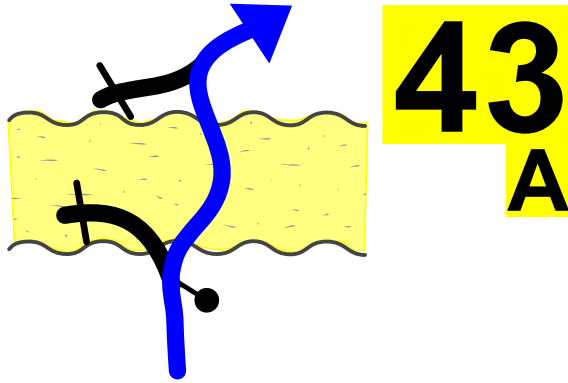

3,82

0,49

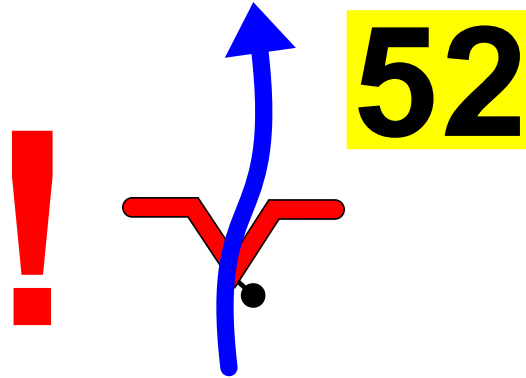

ET à 110m

42

4,26

0,44

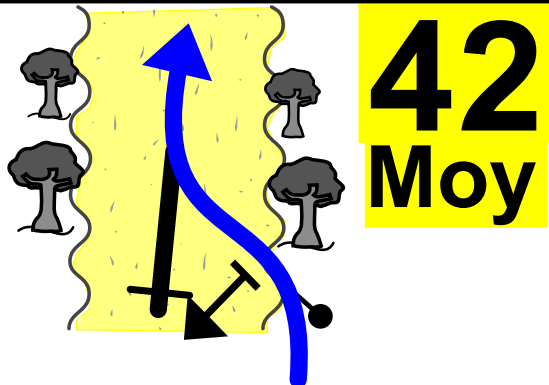

P DS
WADI

4,74

0,48 ↓

28
Moy

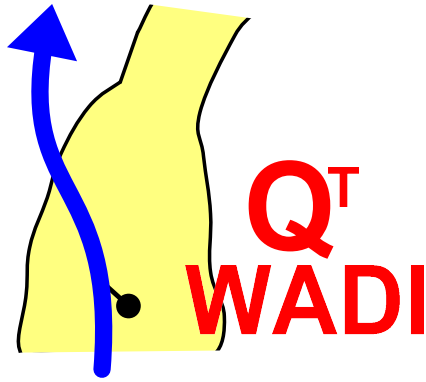

5,04

0,30



295
A

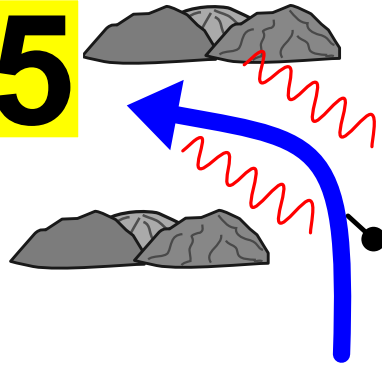

DS
CANYON



5,85

0,81 ↓

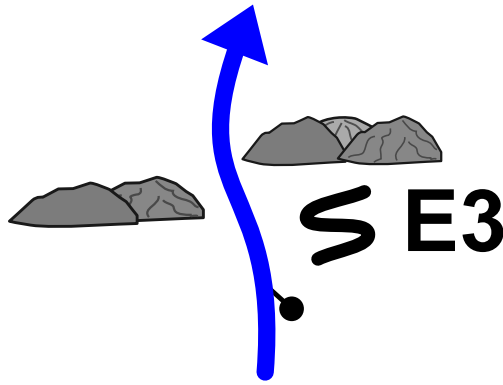

S E3

6,08

0,23

295
A

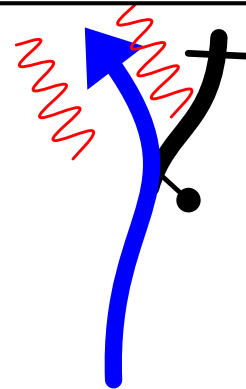

6,45

0,37

292
A

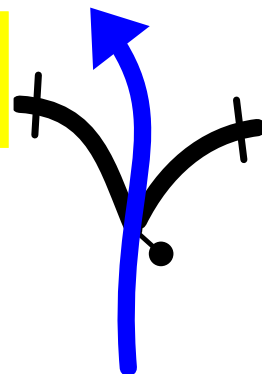

NBX P



7,56

1,11 ↓

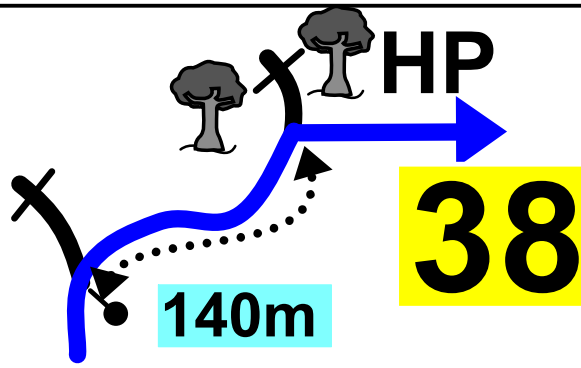

7,82

0,26

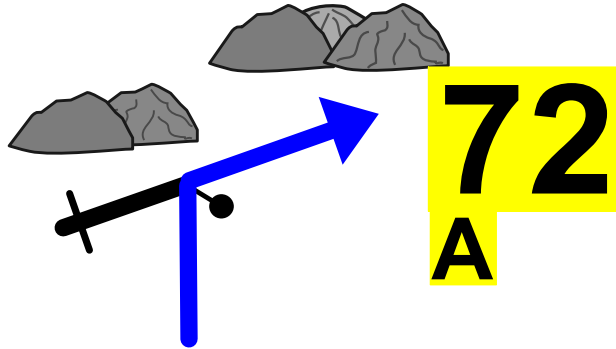

8,58

0,76

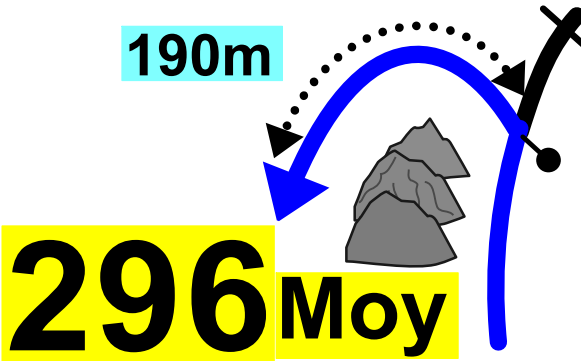

9,52

0,94 ↓

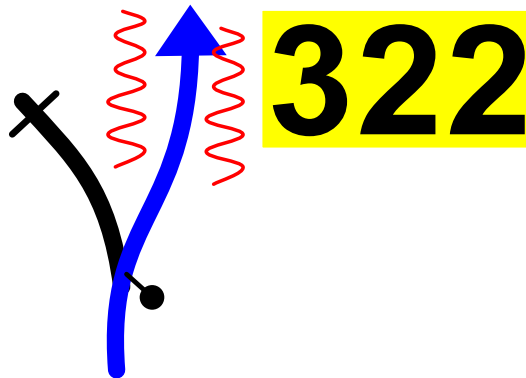

9,70

0,18

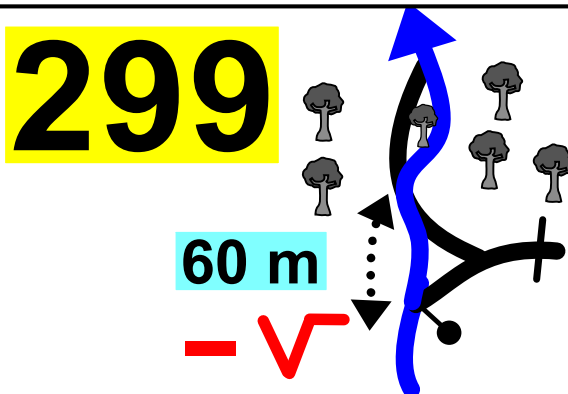

5

/ PRIVATE TEST /

Km : 10,67

10,34

0,64

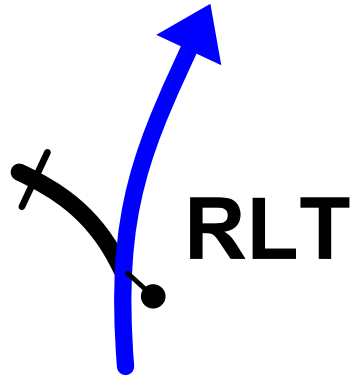

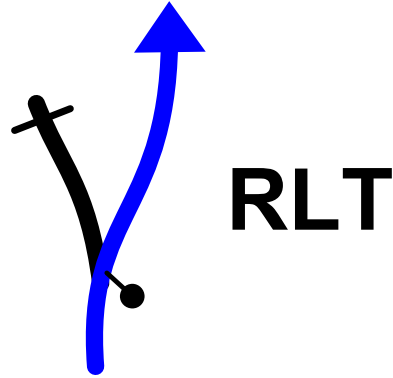

10,68

0,34

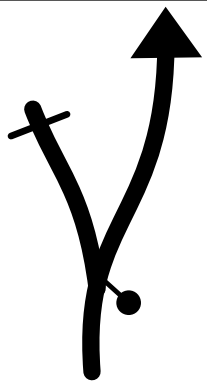
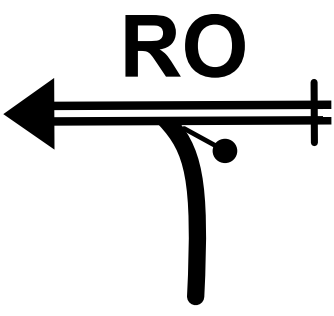
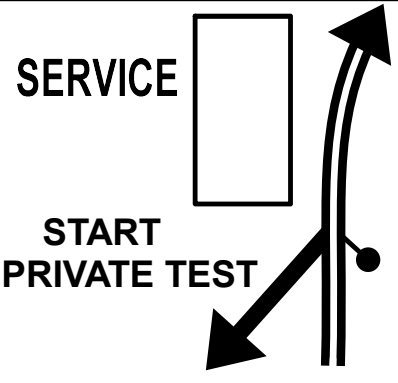
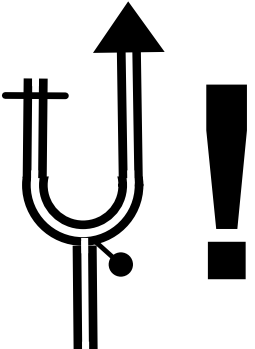
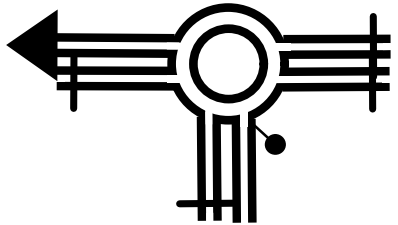

9

Next

1	/ PRIVATE TEST / LIAISON B	Km : 63,75
0,00		
0,00		
6,49		BACK TO STADIUM
5,84		
22,87		 
3,05		

Next 3,88

2

/ PRIVATE TEST / LIAISON B

Km : 63,75

26,75

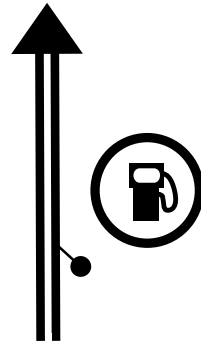

3,88

28,93



2,18



29,91



0,98

32,38



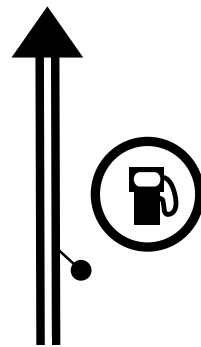

2,47

49,28

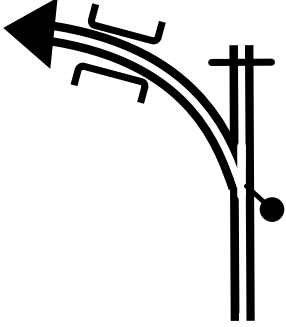
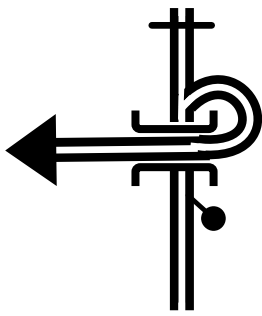
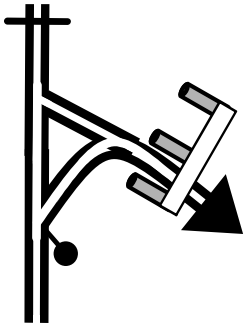

16,90

Next 7,19

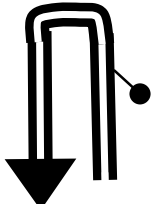
3	/ PRIVATE TEST / LIAISON B	Km : 63,75
<p data-bbox="119 203 391 324">56,47</p> <p data-bbox="70 405 268 504">7,19</p>		<p data-bbox="1181 203 1540 369">ET RP HIGHWAY</p>
<p data-bbox="119 595 391 716">58,48</p> <p data-bbox="70 797 268 896">2,01</p>		<p data-bbox="1173 784 1316 918">WPE</p> <p data-bbox="1436 795 1556 918">12</p>
<p data-bbox="119 987 391 1108">61,30</p> <p data-bbox="70 1189 268 1288">2,82</p>		<p data-bbox="1173 929 1556 1176">KING ABDULA ZIZ SPORT CITY</p> <p data-bbox="1173 1176 1316 1310">WPE</p> <p data-bbox="1436 1187 1556 1310">13</p>
<p data-bbox="119 1379 391 1500">62,79</p> <p data-bbox="70 1581 268 1680">1,49</p>		
<p data-bbox="119 1771 391 1892">63,49</p> <p data-bbox="70 1973 268 2072">0,70</p>	<p data-bbox="734 1724 909 1769">STADIUM</p>  	<p data-bbox="1276 1836 1492 1993">"U" TURN</p>

Next 0,27

4

/ PRIVATE TEST / LIAISON B

Km : 63,75

63,76

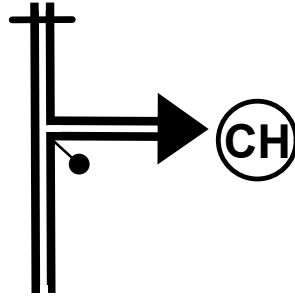

CH LIAISON

14

0,27

Next

