



**TAMA**<sup>®</sup>

**DRUMS AND HARDWARE**

*2021 General Catalog*









## TABLE OF CONTENTS

4-9	STAR Drums
10-21	Starclassic
22-25	S.L.P. Drum Kits
26-27	Superstar Hyper-Drive Duo
28-33	Superstar Classic
34-35	Superstar Classic Neo-Mod
36-37	Imperialstar
38-42	Club-JAM
43-44	Cocktail-JAM
46-52	Snare Drums
53-55	Drum Pedals
55-56	Hi-hat Stands
56-58	Drum Thrones
58-59	Snare Stands
59-60	Cymbal Stands
61-62	Tom Stands & Tom Holders
63	Hardware Kits
64	Power Tower System
65-69	Clamps & Attachments
70-72	Microphone Stands & Accessories
73-75	TAMA Percussion
75-76	Practice Tools
76-84	Bags
84-97	Accessories
98-101	Drum Sticks

# TAMA STAR BUBINGA

## Lacquer Finishes

STAR is the flagship line for TAMA drums. It takes the knowledge and research we cultivated for the Starclassic series to the next level, by reexamining every detail to enhance shell resonance. STAR Bubinga features a thin 5mm shell. Every shell comes equipped with 9mm thick Sound Focus Rings (SFR) for structural support. This shell configuration provides clear projection and resonance to highlight the distinct sound of Bubinga.



**COLOR** Sunset Australian Acacia Burst **SAC**

including:  
22"x16" bass drum  
8"x6" tom tom  
10"x7" tom tom  
12"x8" tom tom  
14"x14" floor tom  
16"x16" floor tom  
14"x6.5" snare drum



**COLOR** Solid Candy Red **SDR**

including:  
20"x16" bass drum  
8"x7" tom tom  
10"x7" tom tom  
12"x7" tom tom  
13"x7.5" tom tom  
14"x12" floor tom  
16"x14" floor tom  
14"x6.5" snare drum



# INDIVIDUAL MODEL NUMBERS

Diameter	Depth	Model No.		
<b>Bass Drums</b>				
16"	12"	TBB1612S		
18"	14"	TBB1814S		
18"	15"	TBB1815S		
18"	16"	TBB1816S		
20"	14"	TBB2014S		
20"	16"	TBB2016S		
20"	17"	TBB2017S		
20"	18"	TBB2018S		
22"	14"	TBB2214S		
22"	16"	TBB2216S		
22"	17"	TBB2217S		
22"	18"	TBB2218S		
24"	14"	TBB2414S		
24"	16"	TBB2416S		
24"	17"	TBB2417S		
24"	18"	TBB2418S		
26"	14"	TBB2614S		
26"	16"	TBB2616S		
<b>Floor Toms</b>				
13"	12"	TBF1312S		
14"	12"	TBF1412S		
14"	13"	TBF1413S		
14"	14"	TBF1414S		
15"	13"	TBF1513S		
15"	14"	TBF1514S		
15"	15"	TBF1515S		
16"	14"	TBF1614S		
16"	15"	TBF1615S		
16"	16"	TBF1616S		
18"	14"	TBF1814S		
18"	15"	TBF1815S		
18"	16"	TBF1816S		

Diameter	Depth	Model No.		
<b>Tom Toms</b>				
8"	6"	TBT0806S		
8"	7"	TBT0807S		
8"	8"	TBT0808S		
10"	6.5"	TBT1065S		
10"	7"	TBT1007S		
10"	8"	TBT1008S		
10"	9"	TBT1009S		
10"	10"	TBT1010S		
12"	7"	TBT1207S		
12"	8"	TBT1208S		
12"	9"	TBT1209S		
12"	10"	TBT1210S		
12"	11"	TBT1211S		
13"	7.5"	TBT1375S		
13"	9"	TBT1309S		
13"	10"	TBT1310S		
13"	11"	TBT1311S		
13"	12"	TBT1312S		
14"	8"	TBT1408S		
14"	10"	TBT1410S		
14"	11"	TBT1411S		
14"	12"	TBT1412S		
14"	13"	TBT1413S		
<b>Snare Drums</b>				
13"	6"	TBS136S		
14"	5.5"	TBS1455S		
14"	6.5"	TBS1465S		
14"	8"	TBS148S		

\*Please ask price for "outside & inside inlay" option.

## MODEL NUMBER SYSTEM - Individual Drums

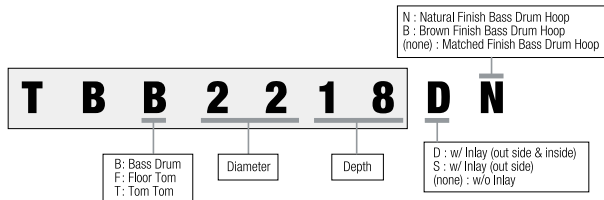

## SPECIFICATIONS

### Shells

5mm, 5ply Bubinga + 1 inner ply Cordia, or 5ply Bubinga + 1 outer ply Australian Acacia + 1 inner Ply Cordia for SAC, or 5ply Bubinga + 1 outer ply Indian Laurel + 1 inner ply Cordia for LNTI, or 4ply Bubinga + 1 outer & 1 inner ply Cordia for CDKG/CDKR, w/ 9mm Sound Focus Rings

### STAR Bearing Edges

### Super Resonant Mounting System

### Quick-Lock Tom Brackets

### Minimum Shell Contact

### STAR Floor Tom Legs

### Hold Tight™ Washers

### Remo® Drum Heads

## FINISHES (Lacquer)



Dark Green Cordia  
CDKG



Dark Red Cordia  
CDKR



Natural Indian Laurel  
LNTI



Sunset Australian Acacia Burst  
SAC NEW



Dark Burgundy Metallic  
DBM



Satin Blue Metallic  
SBM



Antique White  
ATW



Smoky Black  
SKB



Atomic Orange  
AMO



Grand Aqua Blue  
GAQ



Grand Royal Blue  
GYB



Solid Candy Red  
SDR



Piano Black  
PBK



Sunny Yellow Lacquer  
SYL

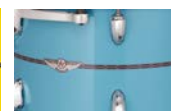

Vintage Sea Blue  
VSB



# TAMA STAR MAPLE

## Lacquer Finishes

STAR is the flagship line for TAMA drums. It takes the knowledge and research we cultivated for the Starclassic series to the next level, by reexamining every detail to enhance shell resonance. STAR Maple shell's "Solid Core Ply" is a totally new design for this series. This unique shell provides the warm, open tone of Maple, combined with the rich, hearty sound of a solid ply shell.



**COLOR** Emerald Sea Curly Maple Burst **RECB**

including:  
22"x16" bass drum  
8"x6" tom tom  
10"x7" tom tom  
12"x8" tom tom  
14"x14" floor tom  
16"x16" floor tom  
14"x6.5" snare drum



**COLOR** Grand Royal Blue **GYB**

including:  
22"x16" bass drum  
10"x7" tom tom  
12"x8" tom tom  
14"x14" floor tom  
16"x16" floor tom  
14"x6.5" snare drum



# INDIVIDUAL MODEL NUMBERS

Diameter	Depth	Model No.		
<b>Bass Drums</b>				
16"	12"	TMB1612S		
18"	14"	TMB1814S		
18"	15"	TMB1815S		
18"	16"	TMB1816S		
20"	14"	TMB2014S		
20"	16"	TMB2016S		
20"	17"	TMB2017S		
20"	18"	TMB2018S		
22"	14"	TMB2214S		
22"	16"	TMB2216S		
22"	17"	TMB2217S		
22"	18"	TMB2218S		
24"	14"	TMB2414S		
24"	16"	TMB2416S		
24"	17"	TMB2417S		
24"	18"	TMB2418S		
26"	14"	TMB2614S		
26"	16"	TMB2616S		
<b>Floor Toms</b>				
13"	12"	TMF1312S		
14"	12"	TMF1412S		
14"	13"	TMF1413S		
14"	14"	TMF1414S		
15"	13"	TMF1513S		
15"	14"	TMF1514S		
15"	15"	TMF1515S		
16"	14"	TMF1614S		
16"	15"	TMF1615S		
16"	16"	TMF1616S		
18"	14"	TMF1814S		
18"	15"	TMF1815S		
18"	16"	TMF1816S		

Diameter	Depth	Model No.		
<b>Tom Toms</b>				
8"	6"	TMT0806S		
8"	7"	TMT0807S		
8"	8"	TMT0808S		
10"	6.5"	TMT1065S		
10"	7"	TMT1007S		
10"	8"	TMT1008S		
10"	9"	TMT1009S		
10"	10"	TMT1010S		
12"	7"	TMT1207S		
12"	8"	TMT1208S		
12"	9"	TMT1209S		
12"	10"	TMT1210S		
12"	11"	TMT1211S		
13"	7.5"	TMT1375S		
13"	9"	TMT1309S		
13"	10"	TMT1310S		
13"	11"	TMT1311S		
13"	12"	TMT1312S		
14"	8"	TMT1408S		
14"	10"	TMT1410S		
14"	11"	TMT1411S		
14"	12"	TMT1412S		
14"	13"	TMT1413S		
<b>Snare Drums</b>				
13"	6"	TMS136S		
14"	5.5"	TMS1455S		
14"	6.5"	TMS1465S		
14"	8"	TMS148S		

\*Please ask price for "outside & inside inlay" option.

## MODEL NUMBER SYSTEM - Individual Drums

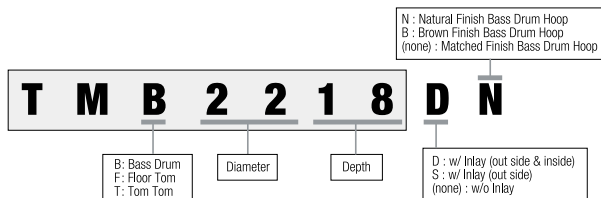

## SPECIFICATIONS

### Shells

5mm, 5ply Maple or 5ply Maple +1 outer ply Curly Maple for RGCM/RECB/ROLC/RRCM w/ 5mm Sound Focus Rings

- STAR Bearing Edges
- Super Resonant Mounting System
- Quick-Lock Tom Brackets
- Minimum Shell Contact
- STAR Floor Tom Legs
- Hold Tight™ Washers
- Remo® Drum Heads

## FINISHES (Lacquer)

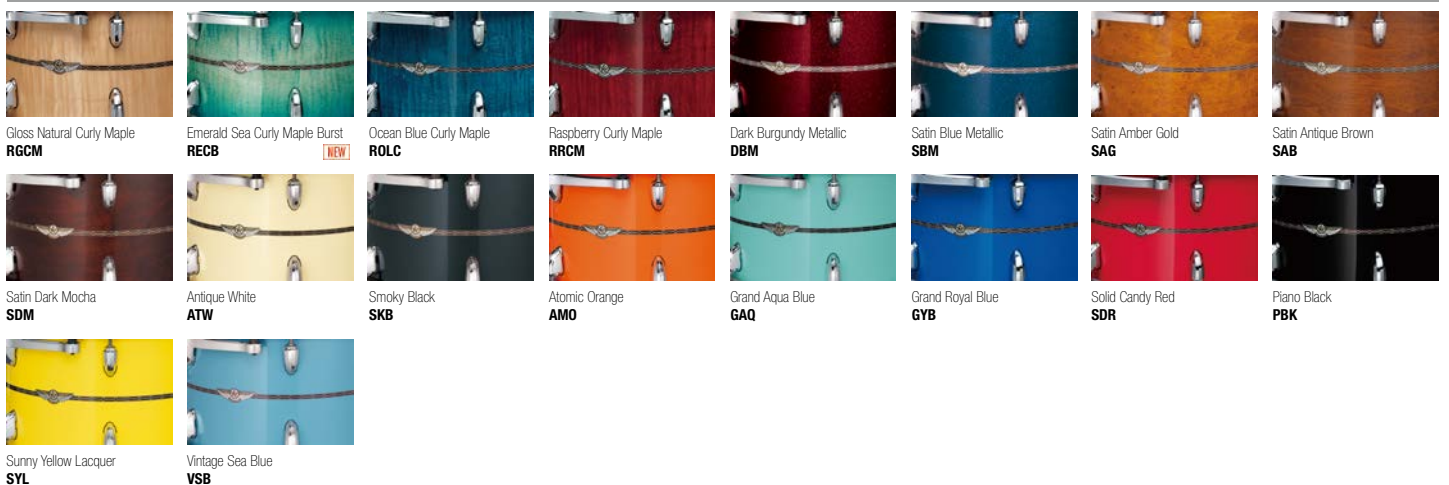



# TAMA STAR WALNUT

## Lacquer Finishes

STAR is the flagship line for TAMA drums. It takes the knowledge and research we cultivated for the Starclassic series to the next level, by reexamining every detail to enhance shell resonance. Walnut has long been favored by furniture makers for both its beauty and durability. As a drum shell material, Walnut's naturally EQ'ed tone has been praised by the drum community for both the stage and the studio. The STAR Walnut shells project booming low end with enough cut to be heard through any mix.



**COLOR** Roasted Japanese Chestnut **RSC**

### TW42RZS basic kit

including:  
 22"x16" bass drum  
 10"x7" tom tom  
 12"x8" tom tom  
 16"x16" floor tom

[add-on]  
 14"x6.5" snare drum

## KIT CONFIGURATIONS LIST

### [20" BD 3pc Shell Kit]

TW30CZS

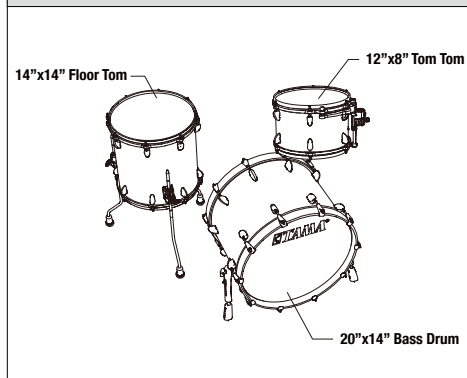

### [22"BD 4pc Shell Kit]

TW42RZS

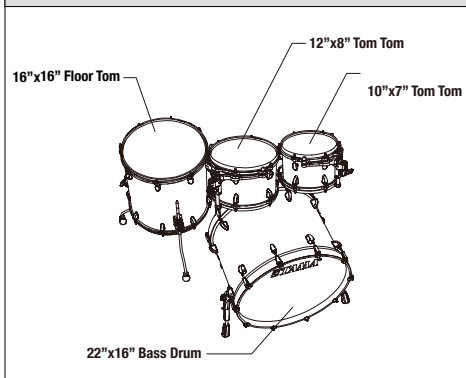

# INDIVIDUAL MODEL NUMBERS

Diameter	Depth	Model No.		
<b>Bass Drums</b>				
16"	12"	TWB1612		
18"	14"	TWB1814		
18"	15"	TWB1815		
18"	16"	TWB1816		
20"	14"	TWB2014		
20"	16"	TWB2016		
20"	17"	TWB2017		
20"	18"	TWB2018		
22"	14"	TWB2214		
22"	16"	TWB2216		
22"	17"	TWB2217		
22"	18"	TWB2218		
24"	14"	TWB2414		
24"	16"	TWB2416		
24"	17"	TWB2417		
24"	18"	TWB2418		
26"	14"	TWB2614		
26"	16"	TWB2616		
<b>Floor Toms</b>				
13"	12"	TWF1312		
14"	12"	TWF1412		
14"	13"	TWF1413		
14"	14"	TWF1414		
15"	13"	TWF1513		
15"	14"	TWF1514		
15"	15"	TWF1515		
16"	14"	TWF1614		
16"	15"	TWF1615		
16"	16"	TWF1616		
18"	14"	TWF1814		
18"	15"	TWF1815		
18"	16"	TWF1816		

Diameter	Depth	Model No.		
<b>Tom Toms</b>				
8"	6"	TWT0806		
8"	7"	TWT0807		
8"	8"	TWT0808		
10"	6.5"	TWT1065		
10"	7"	TWT1007		
10"	8"	TWT1008		
10"	9"	TWT1009		
10"	10"	TWT1010		
12"	7"	TWT1207		
12"	8"	TWT1208		
12"	9"	TWT1209		
12"	10"	TWT1210		
12"	11"	TWT1211		
13"	7.5"	TWT1375		
13"	9"	TWT1309		
13"	10"	TWT1310		
13"	11"	TWT1311		
13"	12"	TWT1312		
14"	8"	TWT1408		
14"	10"	TWT1410		
14"	11"	TWT1411		
14"	12"	TWT1412		
14"	13"	TWT1413		
<b>Snare Drums</b>				
13"	6"	TWS136		
14"	5.5"	TWS1455		
14"	6.5"	TWS1465		
14"	8"	TWS148		

## SPECIFICATIONS

### Shells

All Walnut Shell TT/FT/SD: 6mm 6ply, BD: 7mm 7ply (except ALJB, AGJB, ASBJ, ASCS, LIC, CJC, RSC)

\*ALJB, AGJB, ASBJ, ASCS

TT/FT/SD: 6mm, 4ply Walnut + 2 outer ply Japanese Sen

BD: 7mm, 5ply Walnut + 2 outer ply Japanese Sen

\*LIC, CJC, RSC

TT/FT/SD: 6mm, 5ply Walnut + 1 outer ply Japanese Chestnut

BD: 7mm, 6ply Walnut + 1 outer ply Japanese Chestnut

### STAR Bearing Edges

### Super Resonant Mounting System

### Quick-Lock Tom Brackets

### Minimum Shell Contact

### STAR Floor Tom Legs

### Remo® Drum Heads

## MODEL NUMBER SYSTEM - Individual Drums

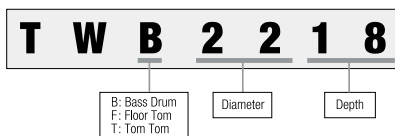

## FINISHES (Lacquer)

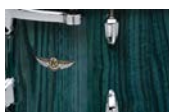

Light Indigo Japanese Chestnut  
**LIC**



Cinnamon Japanese Chestnut  
**CJC**



Roasted Japanese Chestnut  
**RSC**



Indigo Japanese Sen Burst  
**ALJB**



Garnet Japanese Sen Burst  
**AGJB**



Satin Black Japanese Sen Burst  
**ASBJ**

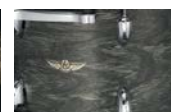

Satin Charcoal Japanese Sen  
**ASCS**



Red Burgundy Walnut  
**RBW**

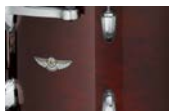

Dark Mocha Walnut  
**DMW**



Mint Green Mist  
**MGN**



Smoky Blue Mist  
**SBU**



Antique White  
**ATW**



Smoky Black  
**SKB**

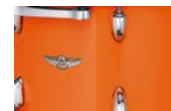

Atomic Orange  
**AMO**



Grand Aqua Blue  
**GAQ**



Grand Royal Blue  
**GYB**



Solid Candy Red  
**SDR**



Piano Black  
**PBK**



Sunny Yellow Lacquer  
**SYL**



Vintage Sea Blue  
**VSB**



# STARCLASSIC MAPLE

## Exotic Finishes

In the '80s TAMA's Superstars and Imperialstars reigned supreme - the perfect drums for the times. But TAMA's builders and designers wanted something that transcended trends, something timeless - drums that understood a player's passion and allowed the expression of every genre, style, mood, and technique. They created Starclassic Maple drums...and ignited the thin-shell revolution. And now the Exotic Finish line offers beautiful, one-of-a-kind exotic wood exteriors for that extra luxurious touch.

Numerous options are available to meet the varied and critical needs of professional drummers including a selection of more than 20 different shell sizes. Starclassic Maple also features three shell hardware finishes to choose from: Black Nickel, Chrome and Smoked Black Nickel. Starclassic Maple is simply an unprecedented combination of sight and sound.



**COLOR** Tobacco Sunburst Movingui VTBV  
w/ smoked black nickel hardware

### ME42TZUS basic kit

including:  
22"x16" bass drum  
10"x7" tom tom  
12"x8" tom tom  
16"x16" floor tom  
[add-on]  
14"x6.5" snare drum

## KIT CONFIGURATIONS LIST

### [20" BD 3pc Shell Kit]

ME30CMS w/ Chrome Hardware  
ME30CMBS w/ Black Nickel Hardware  
ME30CMUS w/ Smoked Black Nickel Hardware

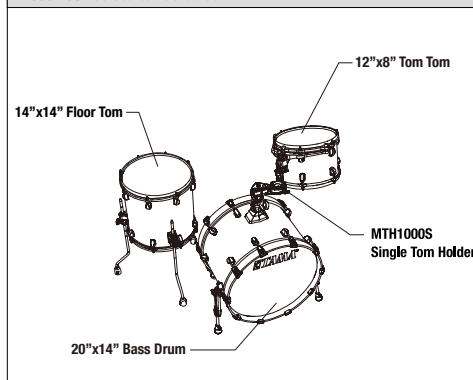

### [22"BD 3pc Shell Kit]

ME32CZS w/ Chrome Hardware  
ME32CZBS w/ Black Nickel Hardware  
ME32CZUS w/ Smoked Black Nickel Hardware

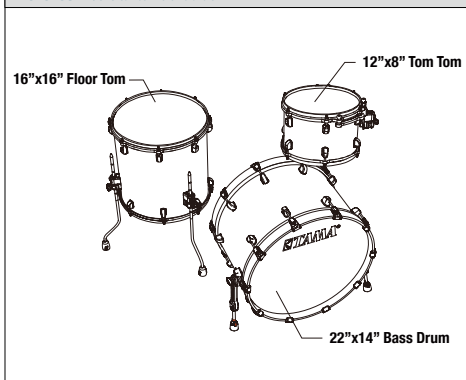

### [22"BD 4pc Shell Kit]

ME42TZS w/ Chrome Hardware  
ME42TZBS w/ Black Nickel Hardware  
ME42TZUS w/ Smoked Black Nickel Hardware

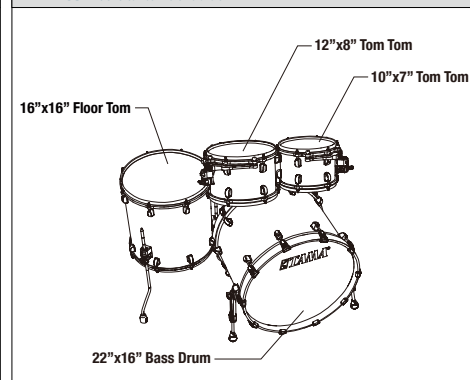

# INDIVIDUAL MODEL NUMBERS

Diameter	Depth	Model No.				
		Black Nickel	Chrome	Smoked Black Nickel		
<b>Bass Drums</b> *To order Bass Drum w/ Tom Holder Base, Please substitute "Z" with "M". Ex MEB2218Z → MEB2218M						
16"	12"	MEB1612ZB	MEB1612Z	MEB1612ZU		
18"	14"	MEB1814ZB	MEB1814Z	MEB1814ZU		
20"	14"	MEB2014ZB	MEB2014Z	MEB2014ZU		
20"	16"	MEB2016ZB	MEB2016Z	MEB2016ZU		
22"	14"	MEB2214ZB	MEB2214Z	MEB2214ZU		
22"	16"	MEB2216ZB	MEB2216Z	MEB2216ZU		
22"	18"	MEB2218ZB	MEB2218Z	MEB2218ZU		
24"	14"	MEB2414ZB	MEB2414Z	MEB2414ZU		
24"	16"	MEB2416ZB	MEB2416Z	MEB2416ZU		
<b>Floor Toms</b>						
13"	12"	MEF1312B	MEF1312	MEF1312U		
14"	12"	MEF1412B	MEF1412	MEF1412U		
14"	14"	MEF1414B	MEF1414	MEF1414U		
16"	14"	MEF1614B	MEF1614	MEF1614U		
16"	16"	MEF1616B	MEF1616	MEF1616U		
18"	16"	MEF1816B	MEF1816	MEF1816U		
<b>Tom Toms</b>						
8"	6"	MET0806B	MET0806	MET0806U		
8"	7"	MET0807B	MET0807	MET0807U		
10"	7"	MET1007B	MET1007	MET1007U		
10"	8"	MET1008B	MET1008	MET1008U		
12"	8"	MET1208B	MET1208	MET1208U		
12"	9"	MET1209B	MET1209	MET1209U		
13"	9"	MET1309B	MET1309	MET1309U		
13"	10"	MET1310B	MET1310	MET1310U		
<b>Snare Drums</b>						
13"	6"	MES136B	MES136	MES136U		
14"	5.5"	MES1455B	MES1455	MES1455U		
14"	6.5"	MES1465B	MES1465	MES1465U		
14"	8"	MES148B	MES148	MES148U		

# SPECIFICATIONS

## Shells

(LEWB/LNWB/LRWB)  
 TT/FT: 5mm 6ply Maple + 1 outer ply Pacific Walnut  
 BD/SD: 7mm 8ply Maple + 1 outer ply Pacific Walnut

(VGLM/VLMM/VTBV)  
 TT/FT: 5mm 6ply Maple + 1 outer ply Movingui  
 BD/SD: 7mm 8ply Maple + 1 outer ply Movingui

Star-Cast Mounting System  
 Quick-Lock Tom Bracket  
 EVANS® Heads  
 Die-Cast Hoops  
 Hold Tight™ Washers  
 Claw Hooks w/ Rubber Spacers  
 Cushioned Floor Tom Legs

# OPTION



Chrome HW



Black Nickel HW



Smoked Black Nickel HW

## MODEL NUMBER SYSTEM - Individual Drums

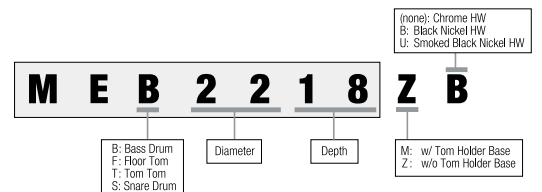

# FINISHES (Lacquer)



Tobacco Sunburst Movingui  
**VTBV**



Gloss Natural Movingui  
**VGLM**

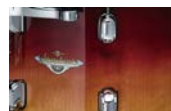

Violet Fade Movingui  
**VVLM**



Ruby Pacific Walnut Burst  
**LRWB**



Emerald Pacific Walnut Burst  
**LEWB**



Natural Pacific Walnut Burst  
**LNWB**



# STARCLASSIC MAPLE

Lacquer Finishes



**COLOR** Molten Electric Blue Burst **MEB**  
w/ black nickel hardware

## MA42TZBNS basic kit

including:

- 22"x16" bass drum
- 10"x7" tom tom
- 12"x8" tom tom
- 16"x16" floor tom

[add-on]

- 14"x6.5" snare drum

## KIT CONFIGURATIONS LIST

### [20" BD 3pc Shell Kit]

- MA30CMS w/ Chrome Hardware
- MA30CBNS w/ Black Nickel Hardware
- MA30CMUS w/ Smoked Black Nickel Hardware

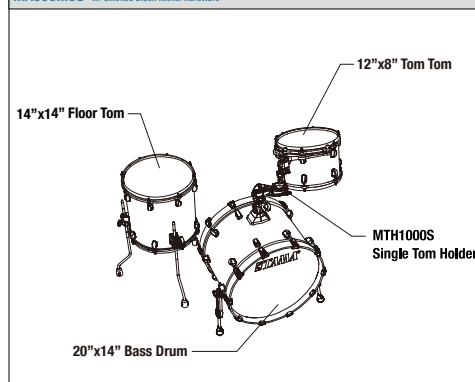

### [22"BD 3pc Shell Kit]

- MA32CZS w/ Chrome Hardware
- MA32CZBNS w/ Black Nickel Hardware
- MA32CZUS w/ Smoked Black Nickel Hardware

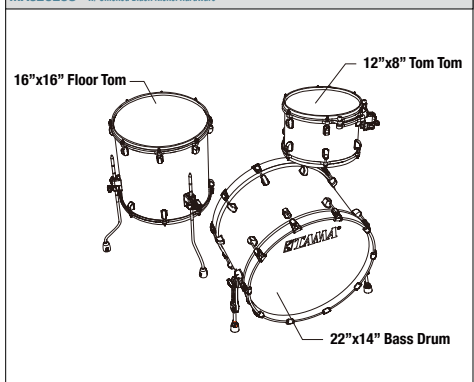

### [22"BD 4pc Shell Kit]

- MA42TZS w/ Chrome Hardware
- MA42TZBNS w/ Black Nickel Hardware
- MA42TZUS w/ Smoked Black Nickel Hardware

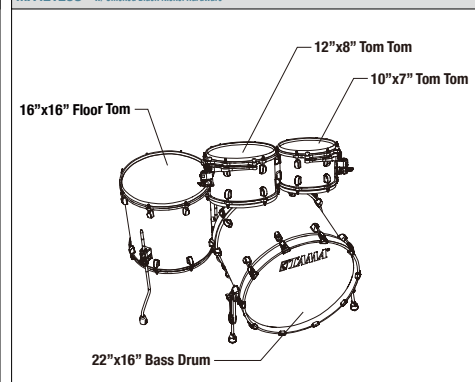

# INDIVIDUAL MODEL NUMBERS

Diameter	Depth	Model No.				
		Black Nickel	Chrome	Smoked Black Nickel		
<b>Bass Drum</b> *To order Bass Drum w/ Tom Holder Base, Please substitute "Z" with "M". Ex. MAB2218Z → MAB2218M						
16"	12"	MAB1612ZBN	MAB1612Z	MAB1612ZU		
18"	14"	MAB1814ZBN	MAB1814Z	MAB1814ZU		
20"	14"	MAB2014ZBN	MAB2014Z	MAB2014ZU		
20"	16"	MAB2016ZBN	MAB2016Z	MAB2016ZU		
22"	14"	MAB2214ZBN	MAB2214Z	MAB2214ZU		
22"	16"	MAB2216ZBN	MAB2216Z	MAB2216ZU		
22"	18"	MAB2218ZBN	MAB2218Z	MAB2218ZU		
24"	14"	MAB2414ZBN	MAB2414Z	MAB2414ZU		
24"	16"	MAB2416ZBN	MAB2416Z	MAB2416ZU		
<b>Floor Toms</b>						
13"	12"	MAF1312BN	MAF1312	MAF1312U		
14"	12"	MAF1412BN	MAF1412	MAF1412U		
14"	14"	MAF1414BN	MAF1414	MAF1414U		
16"	14"	MAF1614BN	MAF1614	MAF1614U		
16"	16"	MAF1616BN	MAF1616	MAF1616U		
18"	16"	MAF1816BN	MAF1816	MAF1816U		
<b>Tom Toms</b>						
8"	6"	MAT0806BN	MAT0806	MAT0806U		
8"	7"	MAT0807BN	MAT0807	MAT0807U		
10"	7"	MAT1007BN	MAT1007	MAT1007U		
10"	8"	MAT1008BN	MAT1008	MAT1008U		
12"	8"	MAT1208BN	MAT1208	MAT1208U		
12"	9"	MAT1209BN	MAT1209	MAT1209U		
13"	9"	MAT1309BN	MAT1309	MAT1309U		
13"	10"	MAT1310BN	MAT1310	MAT1310U		
<b>Snare Drums</b>						
13"	6"	MAS136BN	MAS136	MAS136U		
14"	5.5"	MAS1455BN	MAS1455	MAS1455U		
14"	6.5"	MAS1465BN	MAS1465	MAS1465U		
14"	8"	MAS148BN	MAS148	MAS148U		

# SPECIFICATIONS

**Shells**  
 All Maple Shell  
 TT/FT: 5mm 6ply  
 BD/SD: 7mm 8ply

Star-Cast Mounting System  
 Quick-Lock Tom Bracket  
 EVANS® Heads  
 Die-Cast Hoops  
 Hold Tight™ Washers  
 Claw Hooks w/ Rubber Spacers  
 Cushioned Floor Tom Legs

## OPTION



## MODEL NUMBER SYSTEM - Individual Drums

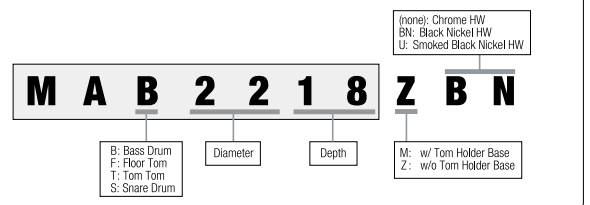

# FINISHES (Lacquer)

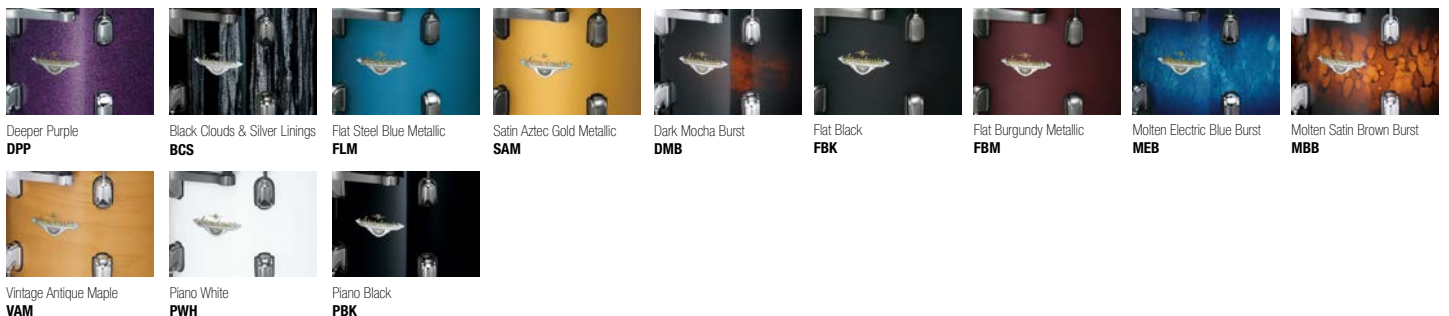



# STARCLASSIC MAPLE

Duracover Wrap Finishes



**COLOR** Surf Green Silk  
w/ smoked black nickel hardware **SGS**

## MR42TZUS basic kit

including:  
22"x16" bass drum  
10"x7" tom tom  
12"x8" tom tom  
16"x16" floor tom

[add-on]  
14"x6.5" snare drum

## KIT CONFIGURATIONS LIST

### [20" BD 3pc Shell Kit]

MR30CMS w/ Chrome Hardware  
MR30CMBNS w/ Black Nickel Hardware  
MR30CMUS w/ Smoked Black Nickel Hardware

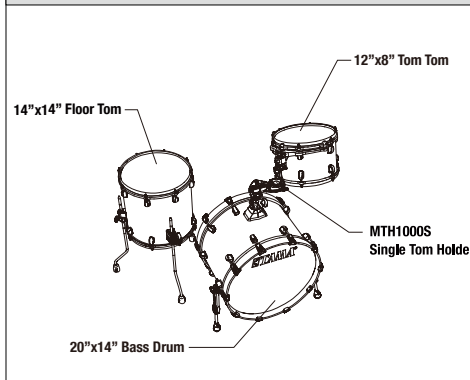

### [22"BD 3pc Shell Kit]

MR32CZS w/ Chrome Hardware  
MR32CZBNS w/ Black Nickel Hardware  
MR32CZUS w/ Smoked Black Nickel Hardware

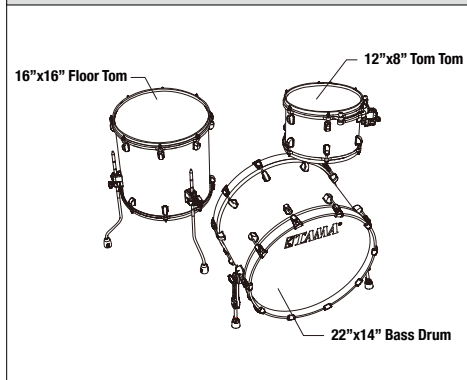

### [22"BD 4pc Shell Kit]

MR42TZS w/ Chrome Hardware  
MR42TZBNS w/ Black Nickel Hardware  
MR42TZUS w/ Smoked Black Nickel Hardware

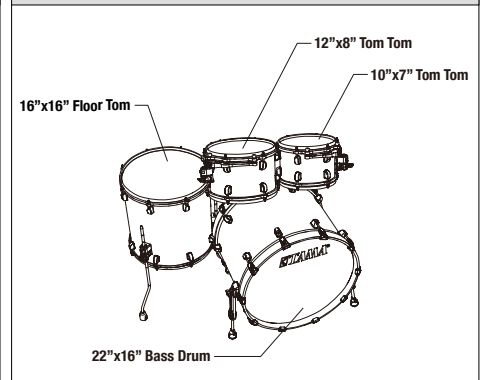

# INDIVIDUAL MODEL NUMBERS

Diameter	Depth	Model No.				
		Black Nickel	Chrome	Smoked Black Nickel		
<b>Bass Drum</b> *To order Bass Drum w/ Tom Holder Base, Please substitute "Z" with "M". Ex MRB2218Z → MRB2218M						
16"	12"	MRB1612ZBN	MRB1612Z	MRB1612ZU		
18"	14"	MRB1814ZBN	MRB1814Z	MRB1814ZU		
20"	14"	MRB2014ZBN	MRB2014Z	MRB2014ZU		
20"	16"	MRB2016ZBN	MRB2016Z	MRB2016ZU		
22"	14"	MRB2214ZBN	MRB2214Z	MRB2214ZU		
22"	16"	MRB2216ZBN	MRB2216Z	MRB2216ZU		
22"	18"	MRB2218ZBN	MRB2218Z	MRB2218ZU		
24"	14"	MRB2414ZBN	MRB2414Z	MRB2414ZU		
24"	16"	MRB2416ZBN	MRB2416Z	MRB2416ZU		
<b>Floor Toms</b>						
13"	12"	MRF1312BN	MRF1312	MRF1312U		
14"	12"	MRF1412BN	MRF1412	MRF1412U		
14"	14"	MRF1414BN	MRF1414	MRF1414U		
16"	14"	MRF1614BN	MRF1614	MRF1614U		
16"	16"	MRF1616BN	MRF1616	MRF1616U		
18"	16"	MRF1816BN	MRF1816	MRF1816U		
<b>Tom Toms</b>						
8"	6"	MRT0806BN	MRT0806	MRT0806U		
8"	7"	MRT0807BN	MRT0807	MRT0807U		
10"	7"	MRT1007BN	MRT1007	MRT1007U		
10"	8"	MRT1008BN	MRT1008	MRT1008U		
12"	8"	MRT1208BN	MRT1208	MRT1208U		
12"	9"	MRT1209BN	MRT1209	MRT1209U		
13"	9"	MRT1309BN	MRT1309	MRT1309U		
13"	10"	MRT1310BN	MRT1310	MRT1310U		
<b>Snare Drums</b>						
13"	6"	MRS136BN	MRS136	MRS136U		
14"	5.5"	MRS1455BN	MRS1455	MRS1455U		
14"	6.5"	MRS1465BN	MRS1465	MRS1465U		
14"	8"	MRS148BN	MRS148	MRS148U		

# SPECIFICATIONS

Shells  
 All Maple Shell  
 TT/FT: 5mm 6ply  
 BD/SD: 7mm 8ply

Star-Cast Mounting System  
 Quick-Lock Tom Bracket  
 EVANS® Heads  
 Die-Cast Hoops  
 Hold Tight™ Washers  
 Claw Hooks w/ Rubber Spacers  
 Cushioned Floor Tom Legs

## OPTION



## MODEL NUMBER SYSTEM - Individual Drums

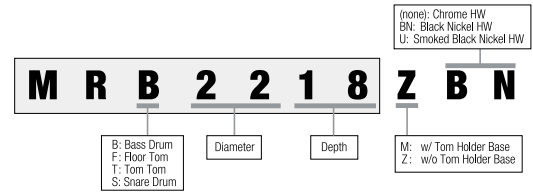

# FINISHES (Duracover Wrap)



Blue and White Oyster  
**BWO**



Red and White Oyster  
**RWO**



Charcoal Swirl  
**CCL**



Vintage Blue Sparkle  
**VBL**



Jade Silk  
**JDL**



Surf Green Silk  
**SGS**



Snow White Pearl  
**SWP**



# STARCLASSIC WALNUT/BIRCH

## Lacquer Finishes

Starclassic Walnut/Birch is a result of extensive experimentation to produce a complex, yet balanced tonal quality. Rich, low-end warmth emanates from carefully selected walnut wood plies. Sonic clarity, attack and defined bright projection are tonal attributes produced by the birch plies. These two wood blend beautifully together to project a contemporary, full-spectrum that is supported by professional level drum hardware features that include Die-cast hoops, Star-Cast Mounting System and Quick-Lock Tom Brackets.



**COLOR** Lacquer Shamrock Oyster LSO

### WBS52LS basic kit

including:  
 22"x16" bass drum  
 10"x8" tom tom  
 12"x9" tom tom  
 14"x12" floor tom  
 16"x14" floor tom  
 MTH1000 double tom holder

[add-on]  
 14"x6.5" snare drum

## KIT CONFIGURATIONS LIST

### [20" BD 3pc Shell Kit]

WBS30RS w/ Chrome Hardware

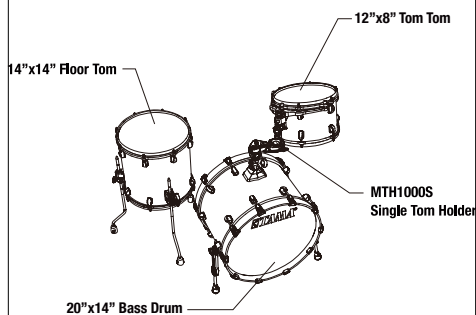

### [22"BD 3pc Shell Kit]

WBS32RZS w/ Chrome Hardware

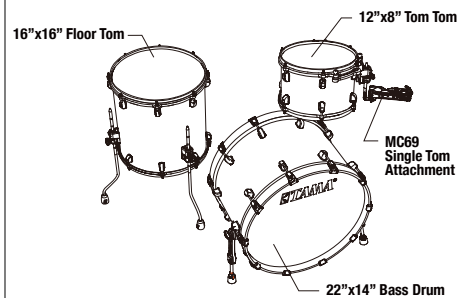

### [22"BD 4pc Shell Kit]

WBS42S w/ Chrome Hardware

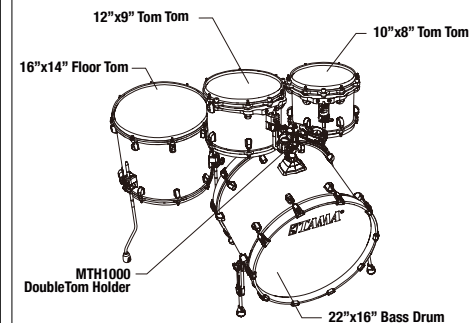

### [22"BD 5pc Shell Kit]

WBS52LS w/ Chrome Hardware

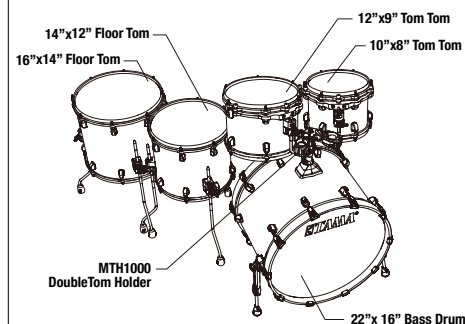

# INDIVIDUAL MODEL NUMBERS

Diameter	Depth	Model No.		
<b>Bass Drums</b> *To order Bass Drum w/ Tom Holder Base, Please substitute "Z" with "M". Ex WBSB22DZ → WBSB22DM				
16"	12"	WBSB16HZ		
18"	14"	WBSB18RZ		
20"	14"	WBSB20RZ		
20"	16"	WBSB20DZ		
22"	14"	WBSB22RZ		
22"	16"	WBSB22DZ		
22"	18"	WBSB22EZ		
24"	16"	WBSB24DZ		
<b>Floor Toms</b>				
13"	12"	WBSF13R		
14"	12"	WBSF14A		
14"	14"	WBSF14D		
16"	14"	WBSF16A		
16"	16"	WBSF16D		
18"	16"	WBSF18D		
<b>Tom Toms</b>				
8"	6"	WBST8H		
8"	7"	WBST8A		
10"	7"	WBST10R		
10"	8"	WBST10A		
12"	8"	WBST12R		
12"	9"	WBST12A		
13"	9"	WBST13R		
13"	10"	WBST13A		
<b>Snare Drums</b>				
13"	6"	WBSS136		
14"	5.5"	WBSS55		
14"	6.5"	WBSS65		
14"	8"	WBSS148		

## MODEL NUMBER SYSTEM - Individual Drums

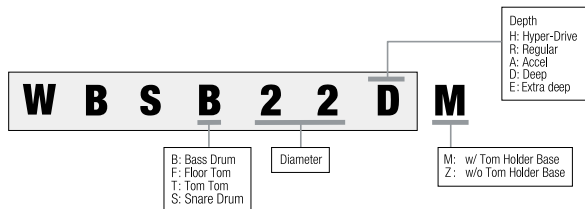

## SPECIFICATIONS

### Shells

TT/FT/SD: 6mm 4ply European Birch + 2 inner ply American Black Walnut  
 BD: 8mm 5ply European Birch + 2 inner ply American Black Walnut

Star-Cast Mounting System      Claw Hooks w/ Rubber Sapcers  
 Quick-Lock Tom Bracket          Cushioned Floor Tom Legs  
 EVANS® Heads                      Die-Cast Hoops

## FINISHES (Lacquer)



Lacquer Ocean Blue Ripple  
**LOR**



Lacquer Phantasm Oyster  
**LPO**



Lacquer Shamrock Oyster  
**LSO**



Satin Purple Atmosphere Fade  
**SAF**



Satin Burgundy Fade  
**SGF**



Satin Sapphire Fade  
**SPF**



Transparent Mocha Fade  
**TMF**



Molten Brown Burst  
**MBR**



Piano Black  
**PBK**

# STARCLASSIC WALNUT/BIRCH

Duracover Wrap Finishes



**COLOR** Surf Green Silk **SGS**

## WBR32RZS basic kit

including:  
 22"x14" bass drum  
 12"x8" tom tom  
 16"x16" floor tom  
 MC69 single tom attachment  
 [add-on]  
 14"x6.5" snare drum

## KIT CONFIGURATIONS LIST

### [20" BD 3pc Shell Kit]

WBR30RS w/ Chrome Hardware

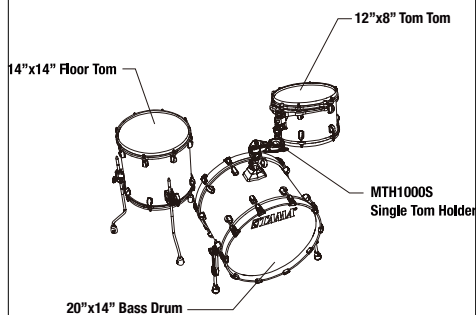

### [22"BD 3pc Shell Kit]

WBR32RZS w/ Chrome Hardware

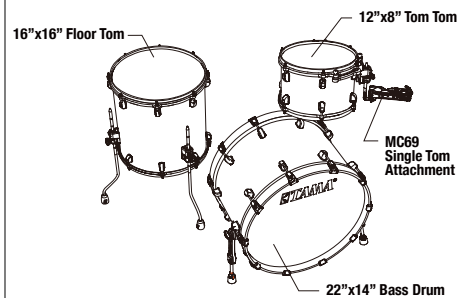

### [22"BD 4pc Shell Kit]

WBR42S w/ Chrome Hardware

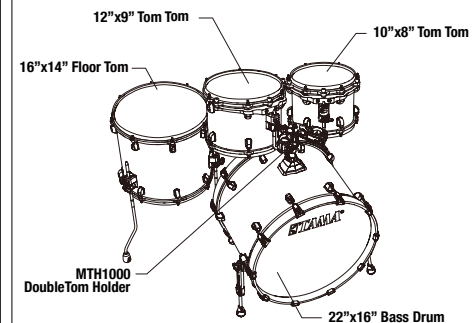

### [22"BD 5pc Shell Kit]

WBR52LS w/ Chrome Hardware

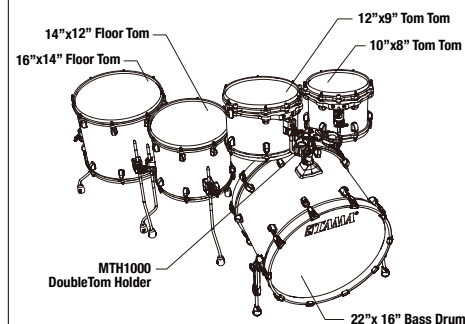



# INDIVIDUAL MODEL NUMBERS

Diameter	Depth	Model No.		
<b>Bass Drums</b> *To order Bass Drum w/ Tom Holder Base, Please substitute "Z" with "M". Ex WBRB22DZ → WBRB22DM				
16"	12"	WBRB16HZ		
18"	14"	WBRB18RZ		
20"	14"	WBRB20RZ		
20"	16"	WBRB20DZ		
22"	14"	WBRB22RZ		
22"	16"	WBRB22DZ		
22"	18"	WBRB22EZ		
24"	16"	WBRB24DZ		
<b>Floor Toms</b>				
13"	12"	WBRF13R		
14"	12"	WBRF14A		
14"	14"	WBRF14D		
16"	14"	WBRF16A		
16"	16"	WBRF16D		
18"	16"	WBRF18D		
<b>Tom Toms</b>				
8"	6"	WBRT8H		
8"	7"	WBRT8A		
10"	7"	WBRT10R		
10"	8"	WBRT10A		
12"	8"	WBRT12R		
12"	9"	WBRT12A		
13"	9"	WBRT13R		
13"	10"	WBRT13A		
<b>Snare Drums</b>				
13"	6"	WBRB136		
14"	5.5"	WBRB55		
14"	6.5"	WBRB65		
14"	8"	WBRB148		

## MODEL NUMBER SYSTEM - Individual Drums

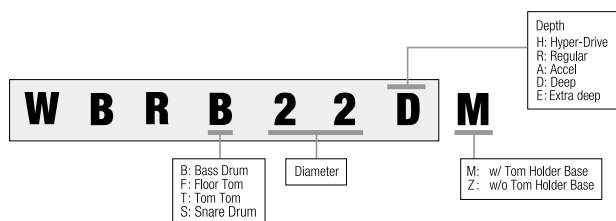

## SPECIFICATIONS

### Shells

TT/FT/SD: 6mm 4ply European Birch + 2 inner ply American Black Walnut  
 BD: 8mm 5ply European Birch + 2 inner ply American Black Walnut

Star-Cast Mounting System    Claw Hooks w/ Rubber Spacers  
 Quick-Lock Tom Bracket        Cushioned Floor Tom Legs  
 EVANS® Heads                    Die-Cast Hoops

## FINISHES (Duracover Wrap)



Jade Silk  
JDL



Red Oyster  
ROY



Surf Green Silk  
SGS



Vintage Marine Pearl  
VMP



Charcoal Onyx  
CCO

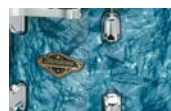

Turquoise Pearl  
TQP

# STARCLASSIC PERFORMER

NEW

## Lacquer Finish

Tama's newest Starclassic Performer series centers on the newest Tama hybrid shell – maple/birch – to offer drummers a complex, powerful and expressive sound supported by rugged Starclassic performance. Tama's Starclassic Performer series evolves the Starclassic legacy to provide a unique Tama sonic component that redefines the art of professional drum set sound and expression at an undeniable value.



**COLOR** Caramel Aurora

**CAR**

### MBS52RZS basic kit

including:

- 22"x16" bass drum
- 10"x7" tom tom
- 12"x8" tom tom
- 14"x12" floor tom
- 16"x14" floor tom
- MC69 single tom attachment (x2)

[add-on]

- 14"x6.5" snare drum

## KIT CONFIGURATIONS LIST

### [22" BD 5pc Shell Kit]

MBS52RZS w/ Chrome Hardware

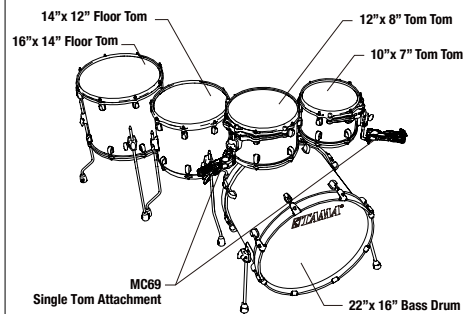

### [22" BD 4pc Shell Kit]

MBS42S w/ Chrome Hardware

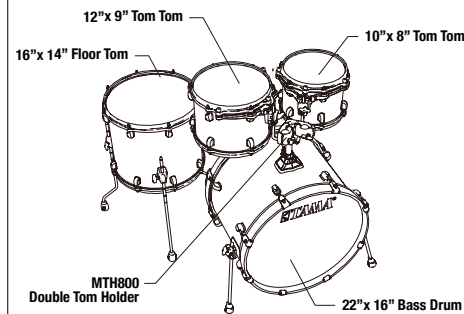

# INDIVIDUAL MODEL NUMBERS

Diameter	Depth	Model No.		
<b>Bass Drums</b> *To order Bass Drum w/ Tom Holder Base, Please substitute "Z" with "M". Ex MBSB22DZ → MBSB22DM				
18"	14"	MBSB18RZ		
20"	14"	MBSB20RZ		
22"	16"	MBSB22DZ		
22"	18"	MBSB22EZ		
24"	16"	MBSB24DZ		
<b>Floor Toms</b>				
14"	12"	MBSF14A		
14"	14"	MBSF14D		
16"	14"	MBSF16A		
18"	16"	MBSF18D		
<b>Tom Toms</b>				
8"	6"	MBST8H		
8"	7"	MBST8A		
10"	7"	MBST10R		
10"	8"	MBST10A		
12"	8"	MBST12R		
12"	9"	MBST12A		
13"	9"	MBST13R		
13"	10"	MBST13A		
<b>Snare Drums</b>				
14"	5.5"	MBSS55		
14"	6.5"	MBSS65		

## MODEL NUMBER SYSTEM - Individual Drums

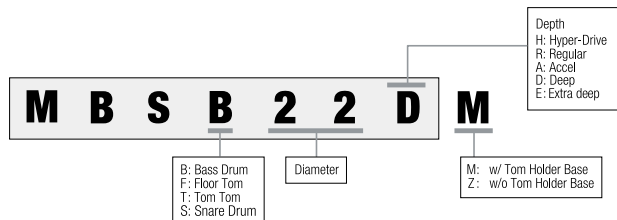

## SPECIFICATIONS

### Shells

TT/FT/SD: 6mm, 4ply Birch + 2 inner ply Maple  
BD: 7mm, 5ply Birch + 2 inner ply Maple

Star-Cast Mounting System Claw Hooks w/ Rubber Sappers  
Cushioned Floor Tom Legs EVANS® Heads  
Die-Cast Hoops

## FINISHES (Lacquer)



Caramel Aurora  
**CAR**



Molten Steel Blue Burst  
**MSL**



Dark Cherry Fade  
**DCF**



Piano Black  
**PBK**





**S.L.A.**  
SOUND LAB PROJECT  
TAMA

**S.L.A.**  
SOUND LAB PROJECT  
TAMA

**TAMA**®

# S.L.P. DRUM KITS -FAT SPRUCE-

## Lacquer Finishes

The Fat Spruce kit features luxurious 100% Spruce shells, which is rarely used as a material on complete drum sets. Its unique sound is fat and open with solid mids and a natural, acoustic vibe not found in more common materials. Furthermore, by utilizing die-cast hoops, it provides a very clear, focused sound.

This kit is also very versatile with a wide tuning range – can go low to medium, optimal for R&B, Blues, and Ballads, or tuned higher to work really well for Jazz and Indie Rock.



**COLOR** Turquoise **TUQ**

### LSP32CS basic kit

including:  
 22"x14" bass drum  
 12"x8" tom tom  
 16"x14" floor tom  
 MTH900BM single tom holder  
 [add-on]  
 LSP146-TUQ 14"x6" snare drum

## KIT CONFIGURATIONS LIST

### [20" BD 3pc Shell Kit]

LSP30CS

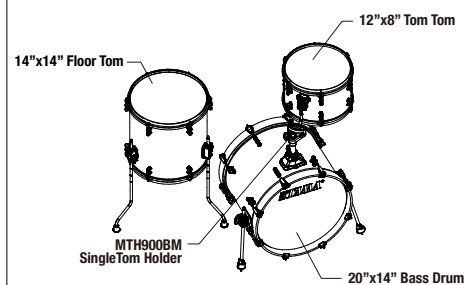

### [22"BD 3pc Shell Kit]

LSP32CS

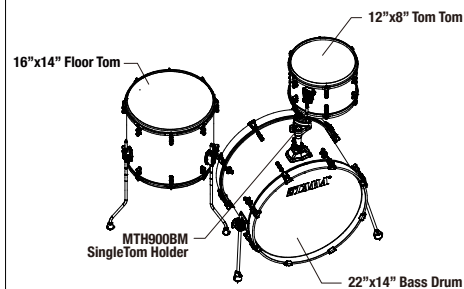

## FINISHES (Lacquer)

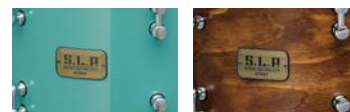

Turquoise  
**TUQ**

Satin Wild Spruce  
**TWS**

## SPECIFICATIONS

### Shells

All Spruce Shell  
 TT/FT: 6mm 6ply, BD: 8mm 8ply

Die-Cast Hoop  
 Direct Flexi-Mount  
 EVANS® G1 Coated Head

## INDIVIDUAL MODEL NUMBERS

Diameter	Depth	Model No.		
<b>Bass Drums</b>				
18"	14"	LSPB18R		
20"	14"	LSPB20R		
22"	14"	LSPB22R		
<b>Floor Toms</b>				
14"	14"	LSPF14D		
16"	14"	LSPF16A		
<b>Tom Toms</b>				
8"	6"	LSPT8HD		
10"	7"	LSPT10RD		
12"	8"	LSPT12RD		
<b>Snare Drum</b>				
14"	6"	LSP146		

# S.L.P. DRUM KITS -DYNAMIC KAPUR-

## Lacquer Finishes

This model features Kapur material, which has caught many drummers' attention for its solid, focused sound and rich mid- to low-end. We paired it with our Sound Arc Hoops for plenty of attack and moderately controlled overtones of the Kapur shells. It offers warm resonance and a very natural, comfortable feel. Because of its slightly dry sound and enhanced attack, it works very well for funk, fusion and gospel. The high volume potential also lends itself perfectly to rock music.



**COLOR** Flat Black **FBK**

### LKP52HTS basic kit

including:  
 22"x16" bass drum  
 10"x6.5" tom tom  
 12"x7" tom tom  
 14"x12" floor tom  
 16"x12" floor tom  
 MTH905N double tom holder

[add-on]  
 LKP1465-FBK 14"x6.5" snare drum

## KIT CONFIGURATIONS LIST

### [22" BD 4pc Shell Kit]

LKP42HTS

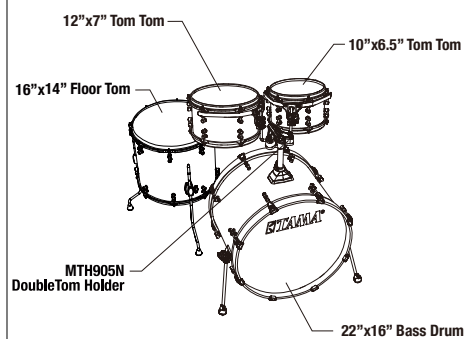

### [22"BD 5pc Shell Kit]

LKP52HTS

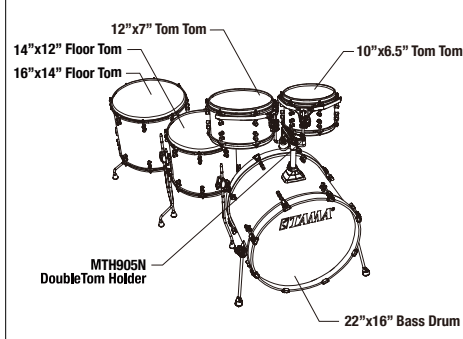

## FINISHES (Lacquer)



Flat Black  
**FBK**

Gloss Black Kapur Burst  
**GKP**

## SPECIFICATIONS

### Shells

All Kapur Shell  
 TT/FT: 6mm Gply, BD: 7mm 7ply

Sound Arc Hoop  
 Star-Mount System  
 Hyper-Drive Toms

## INDIVIDUAL MODEL NUMBERS

Diameter	Depth	Model No.		
<b>Bass Drums</b>				
20"	16"	LKPB20D		
22"	16"	LKPB22D		
<b>Floor Toms</b>				
14"	12"	LKPF14A		
16"	14"	LKPF16A		
<b>Tom Toms</b>				
8"	6"	LKPT8H		
10"	6.5"	LKPT10H		
12"	7"	LKPT12H		
<b>Snare Drum</b>				
14"	6.5"	LKP1465		



# S.L.P. DRUM KITS -NEW VINTAGE HICKORY-

## Lacquer Finish

The S.L.P. New Vintage Hickory kit features a 100% American Hickory shell. Its just as bright and warm as Maple but even clearer in tone. The 2.3mm Steel Mighty Hoops and Evans G1 Coated head are placed on the shells for an open sound. The lacquered brown Bass Drum hoops with Vintage Marine Pearl wrap inlay add a unique vintage feel to this kit.



**COLOR** Satin Vintage Hickory **SVH**

### LHK38CS basic kit

including:  
 18"x14" bass drum  
 12"x8" tom tom  
 14"x14" floor tom  
 MTH900BM single tom holder  
 [add-on]  
 LHK145-SVH 14"x5" snare drum

## KIT CONFIGURATION LIST

[18" BD 3pc Shell Kit]

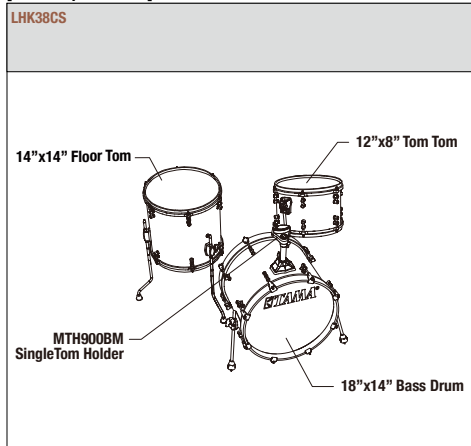

## FINISH (Lacquer)



Satin Vintage Hickory  
**SVH**

## SPECIFICATIONS

Shells  
 All Hickory Shell  
 TT/FT: 5mm 6ply, BD: 7mm 8ply  
 2.3mm Steel Mighty Hoop  
 Direct Flexi-Mount  
 EVANS® G1 Coated Head

## INDIVIDUAL MODEL NUMBERS

Diameter	Depth	Model No.		
<b>Bass Drum</b>				
18"	14"	LHKB18R		
<b>Floor Toms</b>				
14"	14"	LHKF14D		
16"	14"	LHKF16A		
<b>Tom Toms</b>				
8"	6"	LHKT8HD		
10"	7"	LHKT10RD		
12"	8"	LHKT12RD		
<b>Snare Drum</b>				
14"	5"	LHK145		

# SUPERSTAR HYPER-DRIVE DUO

## Lacquer Finishes

Superstar Hyper-Drive Duo is a unique and exciting series which will bring new value to the current drumming world. Similar to the groundbreaking work we did with the Superstar Hyper-Drive's extra shallow toms in 2008 - drawing inspiration from recent performances of cutting-edge drummers - we have once again created distinct drum setups which are poised to inspire drummers. Opening the door to new approaches to drumming beyond the standard. The key component of this series is the 14" x 10" snare drum, which we call the "Duo Snare". This drum is unique not only because of its uncommon 10" depth, but also because it is equipped with floor tom legs and brackets. You can tune this drum low and place it where the first floor tom would traditionally go. As such, the snare can function as a low/deep snare with the snare wires engaged, or as a 14" floor tom with the snares off. This can lead to many unique phrasing opportunities. Once you experience playing on this new kit your eyes and ears will be opened to the infinite range of possibilities, plus it's a lot of fun. Just try it.



**COLOR** Satin Burgundy Vertical Stripe **SGV**

### ML52HZBN2 5pc basic kit

including:  
 22"x16" bass drum  
 10"x6.5" tom tom  
 12"x7" tom tom  
 16"x14" floor tom  
 14"x10" duo snare  
 MC69 single tom attachments (x2)

[add-on]  
 14"x5.5" snare drum

## KIT CONFIGURATIONS LIST

### [20" BD 4pc Shell Kit]

ML40HZBN2

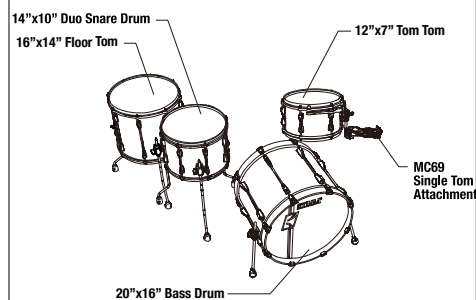

### [22"BD 5pc Shell Kit]

ML52HZBN2

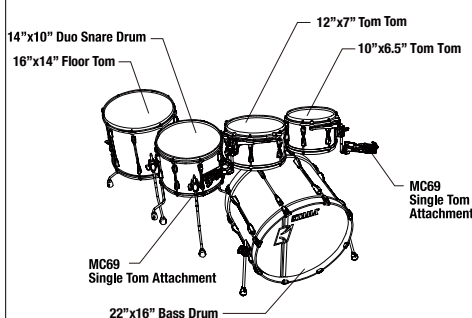

# INDIVIDUAL MODEL NUMBERS

Diameter	Depth	Model No.		
<b>Bass Drums</b>				
20"	16"	MLB20DZBN		
22"	16"	MLB22DZBN		
<b>Floor Toms</b>				
14"	12"	MLF14ALBN		
16"	14"	MLF16ALBN		
18"	16"	MLF18DLBN		
<b>Tom Toms</b>				
8"	6"	MLT8HBN		
10"	6.5"	MLT10HBN		
12"	7"	MLT12HBN		
13"	7.5"	MLT13HBN		
<b>Snare Drums</b>				
13"	6"	MLS136BN		
14"	5.5"	MLS55BN		
14"	6.5"	MLS65BN		
<b>Duo Snare Drum</b>				
14"	10"	MLS1410LBN		

## SPECIFICATIONS

### Shells

All Maple  
TT/FT/SD: 5mm 6ply, BD: 7mm 8ply

Star-Cast Mounting System

Duo Snare

Die-Cast Hoop

EVANS® Power Center Reverse

Dot for Duo Snare

Power Craft II Drum Heads

## FINISHES (Lacquer)



Satin Burgundy Vertical Stripe  
**SGV**



Satin Blue Vertical Stripe  
**SBV**



Satin Silver Vertical Stripe  
**SSV**



Flat Black Vertical Stripe  
**FBV**



# SUPERSTAR CLASSIC MAPLE

## Exotic Finishes

For more than forty years, the Superstar name has stood for groundbreaking design, superior build quality, sterling tone, and clear projection. Superstar Classic once again upholds tradition by raising the bar for discerning drummers—and remarkably—does it while also lowering the price. Drawing on Superstar of the past, its classic TAMA T-shape badge and streamlined low-mass single lugs point to the simpler state of art of the 70's, while the ingenious Star-Mount system and the thinner gauge 100% maple shells eclipse anything in its class.



**COLOR** Gloss Lacebark Pine Fade PGLP

### CL72S 7pc basic kit

- including:
- 22"x18" bass drum
  - 8"x7" tom tom
  - 10"x8" tom tom
  - 12"x9" tom tom
  - 14"x12" floor tom
  - 16"x14" floor tom
  - 14"x6.5" snare drum
  - MTH600 double tom holder
  - MC69 Single Tom Attachment

## KIT CONFIGURATIONS LIST

### [22" BD 5pc Shell Kit]

CL52KS

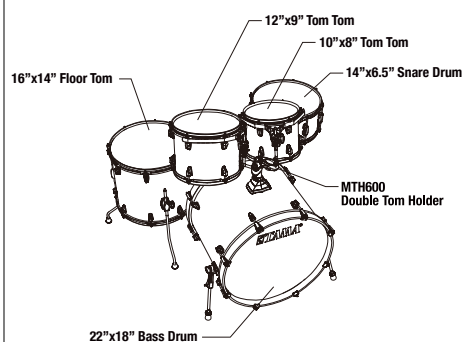

### [22"BD 7pc Shell Kit]

CL72S

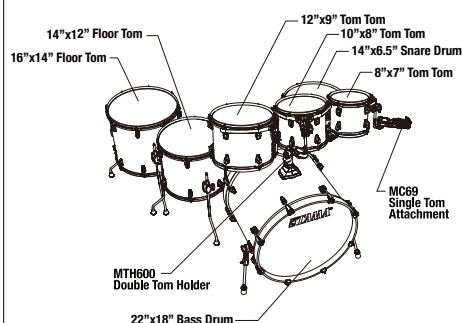

# INDIVIDUAL MODEL NUMBERS

Diameter	Depth	Model No.		
<b>Bass Drums</b>				
18" (w/ bass drum lifter)	14"	CLB18RL		
20"	16"	CLB20D		
22"	18"	CLB22E		
24"	16"	CLB24D		
<b>Floor Toms</b>				
14"	12"	CLF14A		
14"	14"	CLF14D		
16"	14"	CLF16A		
18"	16"	CLF18D		
<b>Tom Toms</b>				
8"	7"	CLT8A		
10"	7"	CLT10R		
10"	8"	CLT10A		
12"	8"	CLT12R		
12"	9"	CLT12A		
13"	10"	CLT13A		
<b>Snare Drums</b>				
14"	5"	CLS145		
14"	6.5"	CLS1465		

## SPECIFICATIONS

### Shells

TT/FT/SD: 5mm 4ply Maple + 2 outer ply Lacebark Pine  
 BD: 7mm 6ply Maple + 2 outer ply Lacebark Pine

Star-Mount System

Low-Mass Lugs

Power Craft II Drum Heads

## FINISHES (Lacquer)



Gloss Java Lacebark Pine  
**PGJP**



Gloss Sapphire Lacebark Pine  
**PGHP**



Gloss Garnet Lacebark Pine  
**PGGP**



Gloss Lacebark Pine Fade  
**PGLP** NEW

# SUPERSTAR CLASSIC MAPLE

Lacquer Finishes



**COLOR** Light Emerald Blue Green **LEG**

## CL72S 7pc basic kit

- including:
- 22"x18" bass drum
  - 8"x7" tom tom
  - 10"x8" tom tom
  - 12"x9" tom tom
  - 14"x12" floor tom
  - 16"x14" floor tom
  - 14"x6.5" snare drum
  - MTH600 double tom holder
  - MC69 Single Tom Attachment

## KIT CONFIGURATIONS LIST

### [18" BD 4pc Shell Kit]

CL48S

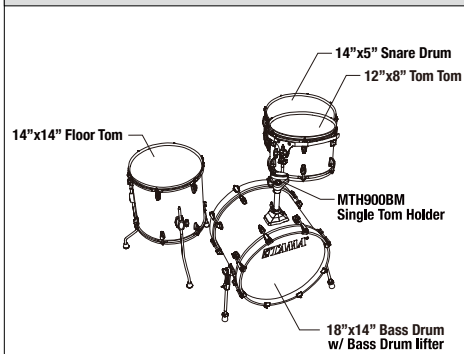

### [20"BD 5pc Shell Kit]

CL50RS

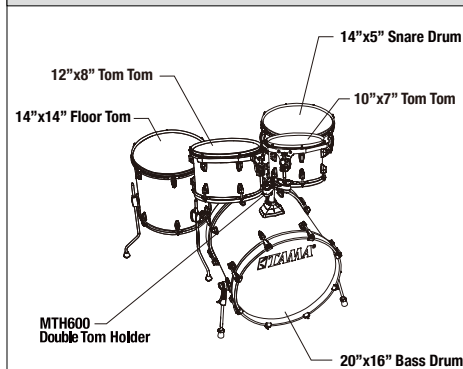

### [22"BD 5pc Shell Kit]

CL52KS

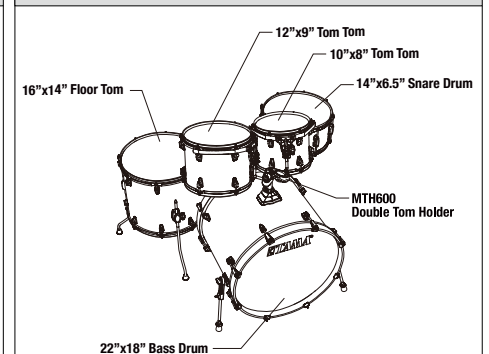

### [22"BD 7pc Shell Kit]

CL72S

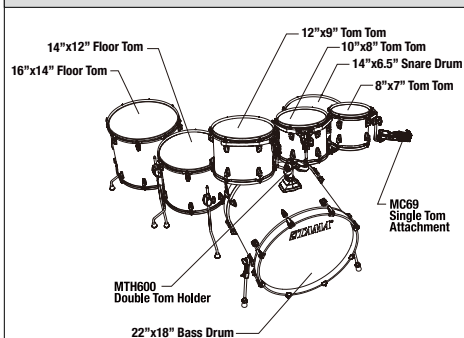



# INDIVIDUAL MODEL NUMBERS

Diameter	Depth	Model No.		
<b>Bass Drums</b>				
18" (w/ bass drum lifter)	14"	CLB18RL		
20"	16"	CLB20D		
22"	18"	CLB22E		
24"	16"	CLB24D		
<b>Floor Toms</b>				
14"	12"	CLF14A		
14"	14"	CLF14D		
16"	14"	CLF16A		
18"	16"	CLF18D		
<b>Tom Toms</b>				
8"	7"	CLT8A		
10"	7"	CLT10R		
10"	8"	CLT10A		
12"	8"	CLT12R		
12"	9"	CLT12A		
13"	10"	CLT13A		
<b>Snare Drums</b>				
14"	5"	CLS145		
14"	6.5"	CLS1465		

## SPECIFICATIONS

### Shells

All Maple Shell  
 TT/FT/SD: 5mm 6ply  
 BD: 7mm 8ply

Star-Mount System

Low-Mass Lugs

Power Craft II Drum Heads

## FINISHES (Lacquer)



Dark Indigo Burst  
**DIB**



Mahogany Burst  
**MHB**



Tangerine Lacquer Burst  
**TLB**



Light Emerald Blue Green  
**LEG**



Transparent Black Burst  
**TPB**

# SUPERSTAR CLASSIC MAPLE

Unicolor Wrap Finishes



**COLOR** Vintage White Sparkle **VWS**

## CK52KS 5pc basic kit

including:  
 22"x18" bass drum  
 10"x8" tom tom  
 12"x9" tom tom  
 16"x14" floor tom  
 14"x6.5" snare drum  
 MTH600 double tom holder

## KIT CONFIGURATIONS LIST

### [18" BD 4pc Shell Kit]

CK48S

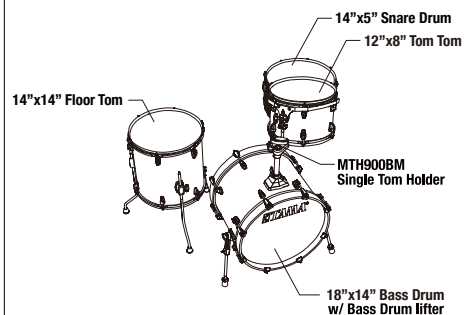

### [20" BD 5pc Shell Kit]

CK50RS

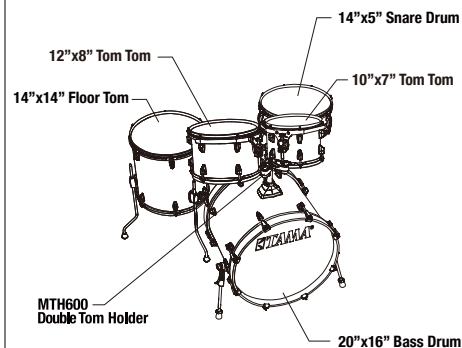

### [22" BD 5pc Shell Kit]

CK52KS

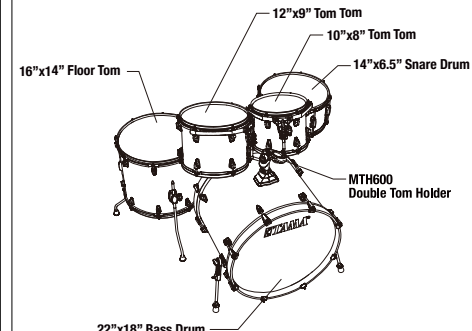

### [22" BD 7pc Shell Kit]

CK72S

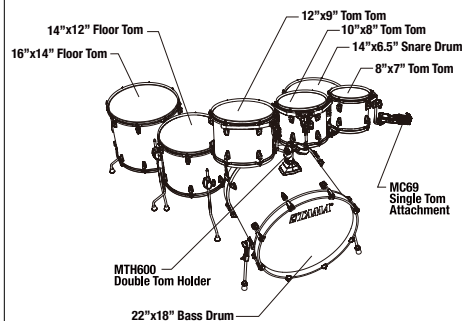

# INDIVIDUAL MODEL NUMBERS

Diameter	Depth	Model No.		
<b>Bass Drums</b>				
18" (w/ bass drum lifter)	14"	CKB18RL		
20"	16"	CKB20D		
22"	18"	CKB22E		
24"	16"	CKB24D		
<b>Floor Toms</b>				
14"	12"	CKF14A		
14"	14"	CKF14D		
16"	14"	CKF16A		
18"	16"	CKF18D		
<b>Tom Toms</b>				
8"	7"	CKT8A		
10"	7"	CKT10R		
10"	8"	CKT10A		
12"	8"	CKT12R		
12"	9"	CKT12A		
13"	10"	CKT13A		
<b>Snare Drums</b>				
14"	5"	CKS145		
14"	6.5"	CKS1465		

## SPECIFICATIONS

### Shells

All Maple Shell  
 TT/FT/SD: 5mm 6ply  
 BD: 7mm 8ply

Star-Mount System

Low-Mass Lugs

Power Craft II Drum Heads

## FINISHES (Unicolor Wrap)



Indigo Sparkle  
ISP



Midnight Gold Sparkle  
MGD



Dark Red Sparkle  
DRP



Vintage White Sparkle  
VWS

# SUPERSTAR CLASSIC NEO-MOD

## Lacquer Finishes

The Superstar Classic Neo-Mod kit is vintage inspired while incorporating modern build technology. Thin, 100% Maple shells featuring 5mm, 6-ply for the tom and floor tom, and 7mm, 8-ply for the bass drum. The unique kit consists of a 20"x10" bass drum, 12"x7" tom, and 14"x9" floor tom with legs. The specialized 10" deep x 20" diameter bass drum delivers clear attack, punch and power, for a strong sound in a variety of playing situations as well as easy transport and set-up.



**COLOR** Metallic Gold Duco **MLD**

### CL30VS 3pc basic kit

including:  
 20"x10" bass drum  
 12"x7" tom tom  
 14"x9" floor tom  
 MTH1000S single tom holder

[add-on]  
 LAL1455 14"x5.5" snare drum

## KIT CONFIGURATION LIST

### [20" BD 3pc Shell Kit]

CL30VS

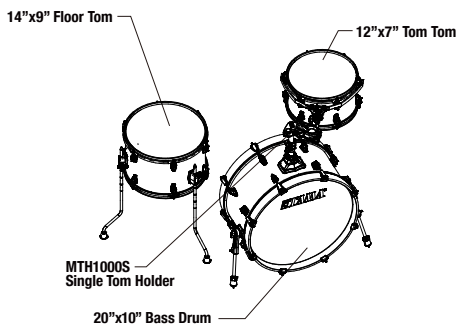

## SPECIFICATIONS

### Shells

All Maple Shell  
 TT/FT/SD: 5mm 6ply  
 BD: 7mm 8ply

Unique Compact Configuration  
 Star-Mount System  
 Low-Mass Lugs  
 Power Craft II Drum Heads

## FINISHES (Lacquer)



Metallic Gold Duco  
**MLD**

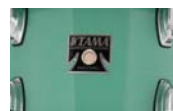

Seafoam Green  
**SFG**



Mod Blue Duco  
**MBD**



White Smoke  
**WSM**



# SUPERSTAR CLASSIC NEO-MOD

Duracover Wrap Finish



**COLOR** Turquoise Satin Haze

**TSH**

## CR30VS 3pc basic kit

including:

20"x10" bass drum  
12"x7" tom tom  
14"x9" floor tom  
MTH1000S single tom holder

[add-on]

LAL1455 14"x5.5" snare drum

## KIT CONFIGURATION LIST

[20" BD 3pc Shell Kit]

CR30VS

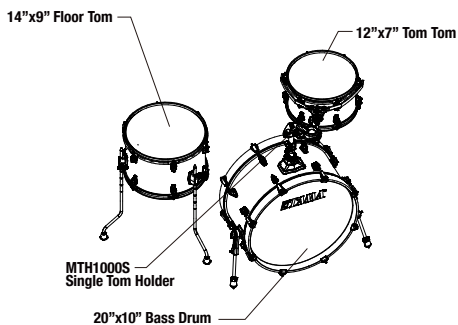

## SPECIFICATIONS

Shells

All Maple Shell  
TT/FT/SD: 5mm 6ply  
BD: 7mm 8ply

Unique Compact Configuration  
Star-Mount System  
Low-Mass Lugs  
Power Craft II Drum Heads

## FINISH (Duracover Wrap)



Turquoise Satin Haze

**TSH**

# IMPERIALSTAR

## Unicolor Wrap Finishes

With over 40 years of drum building experience, TAMA knows what drummers really want. With this in mind we sought out to design an affordable yet durable kit that retained many high-end features you'll find in our Superstar, and Starclassic lines. What we came up with was Imperialstar. Every aspect of the modern drum kit was exhaustively examined, reexamined, and then improved before it was accepted as part of the Imperialstar design.



**COLOR** Natural Zebrawood Wrap **NZW**

### IE52C 22" Bass Drum 5pc basic kit

**Drums:**  
22"x16" bass drum, 10"x7" & 12"x8" tom toms, 16"x15" floor tom, 14"x5" snare drum.

**Hardware:**  
double tom holder, hi-hat stand, drum pedal, snare stand, boom cymbal stand, straight cymbal stand, drum throne.

### [MEINL HCS Brass Cymbals]

All the kits come with Meinl HCS Brass cymbals

## KIT CONFIGURATIONS LIST

### [18"BD 5pc Kit w/ Hardware]

IE58C w/ 14"HH + 18"CR

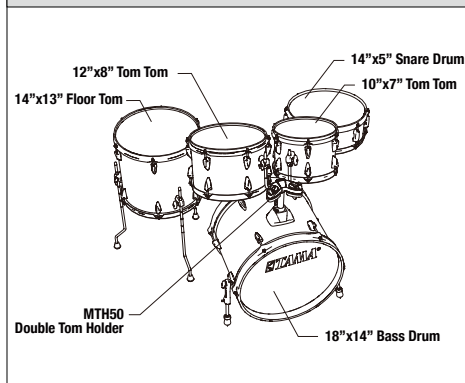

### [20"BD 5pc Kit w/ Hardware]

IE50C w/ 14"HH + 16"C +20"R

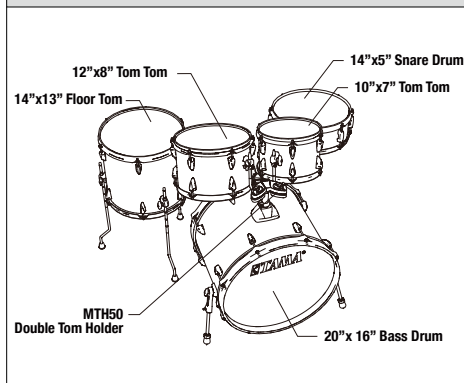

### [22"BD 5pc Kit w/ Hardware]

IE52C w/ 14"HH + 16"C +20"R

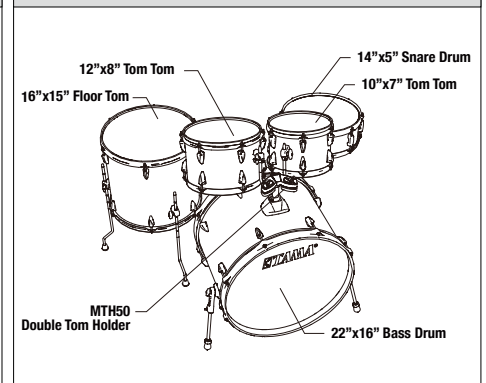

### [22"BD 6pc Kit w/ Hardware]

IE62C w/ 14"HH + 16"C +20"R

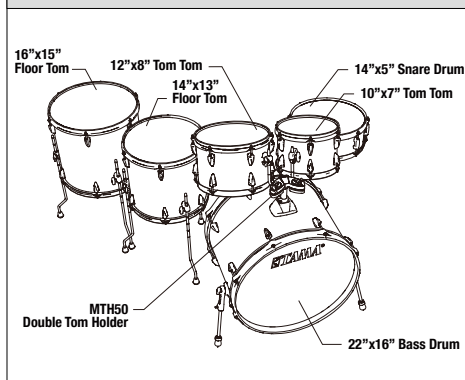

# INDIVIDUAL MODEL NUMBERS

Diameter	Depth	Model No.		
<b>Bass Drums</b>				
18"	14"	IEB18R		
20"	16"	IEB20D		
22"	16"	IEB22D		
<b>Floor Toms</b>				
14"	13"	IEF14R		
16"	15"	IEF16R		
18"	16"	IEF18D		
<b>Tom Toms</b>				
8"	6.5"	IET8H		
10"	7"	IET10R		
12"	8"	IET12R		
13"	9"	IET13R		
<b>Snare Drums</b>				
14"	5"	IES145		
14"	6.5"	IES1465		

## SPECIFICATIONS

### Shells

All Poplar Shell: 8mm 6ply

Omnisphere Tom Holder  
 Accu-Tune Bass Drum Hoops  
 Double Braced Hardware

## FINISHES (Unicolor Wrap)



Black Oak Wrap  
**BOW**



Burgundy Walnut Wrap  
**BWW**



Natural ZebraWood Wrap  
**NZW**



Vintage White Sparkle  
**VWS**



Candy Apple Mist  
**CPM**



Hairline Black  
**HBK**



Hairline Blue  
**HLB**

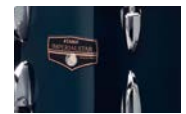

Dark Blue  
**DB**

# CLUB-JAM

## Lacquer Finish

The "Club-JAM" Kit adopts some ideas from vintage kits, such as a cymbal holder mounted directly on the bass drum shell and curved bass drum spurs, further setting it apart from the typical compact kit. Focused yet deep sound from Poplar shell is just right for small and intimate gigs. Its compact size and configuration make it ideal for working drummers, and it fits comfortably on just about any stage.



**COLOR** Satin Blonde **SBO**

### LJL48S 18" Bass Drum 4pc basic kit

**Drums:**

18"x12" bass drum w/cymbal arm bracket, 10"x7" tom tom, 14"x7" floor tom, 13"x5" snare drum.

**Hardware:**

single tom holder, cymbal holder.

## KIT CONFIGURATION LIST

[18"BD 4pc Shell Kit]

LJL48S

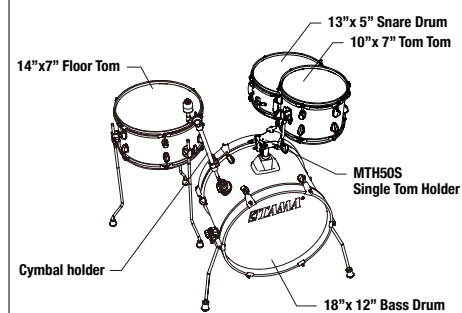

## SPECIFICATIONS

**Shells**

7mm 5ply Poplar+ 1 outer ply Phoenix Tree

Bass Drum Mounted Cymbal Holder  
 Bass Drum Wood Hoops  
 Compact Sizes for Easy Transport  
 DSS48LJ Bag Set Sold Separately

## FINISH (Lacquer)



Satin Blonde  
**SBO**



# CLUB-JAM

Unicolor Wrap Finishes



**COLOR** Aqua Blue **AQB**

## LJK48S 18" Bass Drum 4pc basic kit

**Drums:**

18"x12" bass drum w/cymbal arm bracket, 10"x7" tom tom, 14"x7" floor tom, 13"x5" snare drum.

**Hardware:**

single tom holder, cymbal holder.

## KIT CONFIGURATION LIST

[18"BD 4pc Shell Kit]

LJK48S

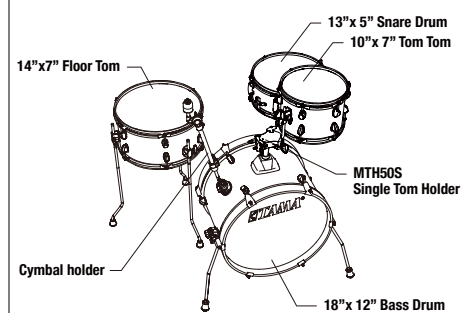

## SPECIFICATIONS

**Shells**

All Poplar Shell: 8mm 6ply

Bass Drum Mounted Cymbal Holder  
 Bass Drum Wood Hoops  
 Compact Sizes for Easy Transport  
 DSS48LJ Bag Set Sold Separately

## FINISHES (Unicolor Wrap)



Aqua Blue  
AQB



Charcoal Mist  
CCM



Galaxy Silver  
GXS

# CLUB-JAM MINI

## Unicolor Wrap Finishes

The simple and sweet TAMA Club-JAM Mini kit is just a kick and snare. Its clear yet deep sound from the Poplar shell is just right for those small and intimate gigs. While its compact size and configuration fit comfortably at any small venue or street show. The Drum Bag Set for this kit (DSS28LJ) allows for smooth transportation (sold separately). If one needs to configure it as a regular drum kit, also available are add-on drums including the 10"x7" tom tom with attachment and a 14"x7" floor tom.



**COLOR** Charcoal Mist **CCM**

### LJK28S 18" Bass Drum 2pc basic kit

**Drums:**

18"x7" bass drum w/cymbal arm bracket, 12"x5" snare drum.

**[CACLJ cymbal arm (sold separately)]**

### LJKT10F14 Add-on pack

Add-on tom and floor tom package is sold separately.  
10"x7" tom tom, 14"x7" floor tom, single tom attachment



## KIT CONFIGURATION LIST

[18"BD 2pc Shell Kit]

LJK28S

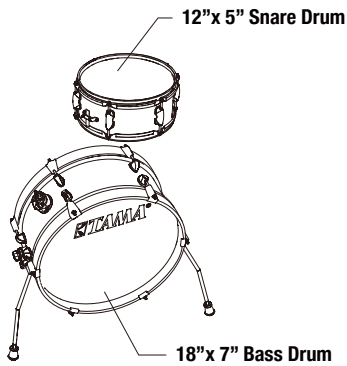

## SPECIFICATIONS

Shells

All Poplar Shell: 8mm 6ply

Bass Drum Wood Hoops

Cymbal Holder Bracket

LJKT10F14 Add-on Kit sold separately  
(10"x7" TT, 14"x7" FT, Single Tom Attachment)

DSS28LJ Bag Set Sold Separately

## FINISHES (Unicolor Wrap)



Aqua Blue  
AQB



Charcoal Mist  
CCM



Galaxy Silver  
GXS

# CLUB-JAM SUITCASE NEW

## Unicolor Wrap Finishes

TAMA Club-JAM Suitcase kit features the ultimate portability, and is the perfect addition to the Club-JAM family. Club-Jam features poplar shells for full drum tone with the convenience of single case portability. The 15" deep/16" diameter bass drum can be divided into two pieces, allowing the tom tom and floor tom to be packed-up like a suitcase. The tom tom and FT bag fit inside the bass drum shell, thus allowing the entire kit to be transported inside the bass drum bag. Specially designed bag set (DSS36LJ, sold separately) includes bass drum bag, tom bag and floor tom bag. A bass drum mounted cymbal arm clamp is included, which allows CACLJ Cymbal Arm (sold separately) to mount on the bass drum for convenient cymbal placement. A bass drum lift is also included to provide varied bass drum beater impact positioning.



**COLOR** Indigo Sparkle **ISP**

### **LJK36S 16" Bass Drum 3pc basic kit**

**Drums:**  
16"x15" bass drum w/ bass drum lifter & cymbal arm bracket, 10"x7" tom tom, 12"x6" floor tom.

**Hardware:**  
single tom attachment.

**[CACLJ cymbal arm (sold separately)]**

## KIT CONFIGURATION LIST

[16"BD 3pc Shell Kit]

LJK36S

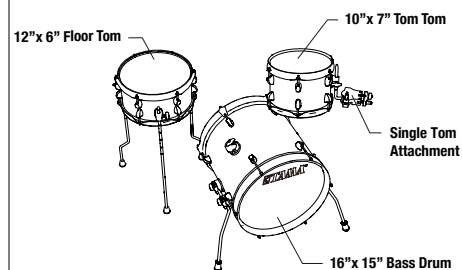

## SPECIFICATIONS

### Shells

All Poplar Shell: 8mm 6ply

Bass Drum Lifter

Bass Drum Natural Wood Hoops

Cymbal Holder Bracket

Compact Nesting Design

DSS36LJ Bag Set Sold Separately

## FINISH (Unicolor Wrap)



Indigo Sparkle  
ISP

NEW

# CLUB-JAM FLYER

## Unicolor Wrap Finishes

TAMA Club-JAM Flyer is the ultimate compact-sized drum kit. It features a 14"x10" bass drum with bass drum lifter, 8"x6" tom tom, 10"x9" floor tom and a 10"x5" snare drum. The Club-JAM Flyer kit delivers a very-well balanced authentic drum sound despite its smaller-sized shells. The Club-JAM Flyer kit's compact size and configuration make it perfect for any small venue or street show. A special drum bag set for the Club-JAM Flyer kit allows for easy transportation (DSS44LJ / sold separately).



**COLOR** Aqua Blue **AQB**

### LJK44S 14" Bass Drum 4pc basic kit

**Drums:**

14"x10" bass drum w/ bass drum lifter & cymbal arm bracket, 8"x6" tom tom, 10"x9" floor tom, 10"x5" snare drum.

**Hardware:**

single tom holder.

### [CACLJ cymbal arm (sold separately)]

List : \$60.00

## KIT CONFIGURATION LIST

[14"BD 4pc Shell Kit]

LJK44S

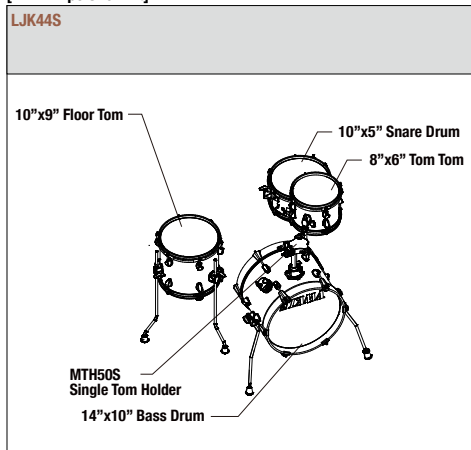

## SPECIFICATIONS

**Shells**

All Poplar Shell: 8mm 6ply

Bass Drum Lifter

Bass Drum Natural Wood Hoops

Cymbal Holder Bracket

Compact Sizes for Easy Transport

DSS44LJ Bag Set Sold Separately

## FINISHES (Unicolor Wrap)



Aqua Blue  
**AQB**

**NEW**

Candy Apple Mist  
**CPM**



# COCKTAIL-JAM

## Unicolor Wrap Finishes

The Cocktail-JAM Kit™ is a TAMA original in both appearance and sound. It's ideal for hip-hop, jazz, intimate acoustic settings, and tight rehearsal rooms. Completely compact, this kit can easily be set up and played using a throne in spaces much smaller than a typical drum set. Additionally, the Cocktail-JAM Kit and its hardware can be easily packed into just two bags (included with the kit), making it super portable and easy to transport to any gig.



**COLOR** Bright Orange Sparkle **BOS**

### CJB46 basic kit

**Drums:**  
16"x6" bass drum, 10"x5" tom tom, 14"x5.5" floor tom, 12"x5" snare drum, Sound Focus Pad, drum bag, hardware bag.

**Hardware:**  
single tom attachments (x2), single pedal.

### [MCAX5366 clamp kit]

**Hardware:**  
cymbal attachment & hi-hat attachment pack (sold separately)

## KIT CONFIGURATION LIST

[16"BD 4pc Kit with clamp kit]

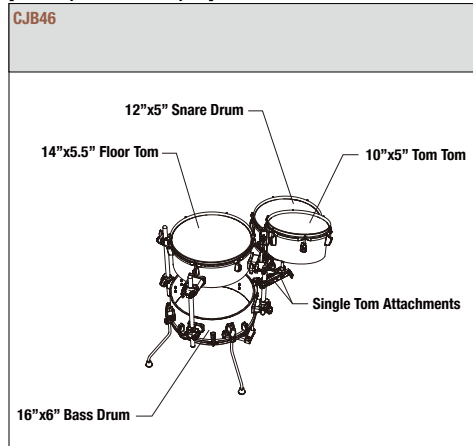

## SPECIFICATIONS

### Shells

All Birch Shells  
TT/FT/SD: 6mm 6ply  
BD: 8mm 7ply

Sound Focus Pad

Specially Designed Bags Included

## FINISHES (Unicolor Wrap)



Bright Orange Sparkle  
**BOS**



Indigo Sparkle  
**ISP**



Midnight Gold Sparkle  
**MGD**

# COCKTAIL-JAM MINI

## Unicolor Wrap Finishes

TAMA Cocktail-JAM Mini is a compact and easy-to-transport drum kit. Its drums are 2 inches smaller in diameter than the full-size Cocktail-JAM Kit. It is compact in size but very scalable, allowing you to add cymbals and cowbells by using our compact clamps and attachments. You can pack the entire kit and its hardware easily into just two bags, which are included with the kit. Also includes tom mounting arms and single bass drum pedal.



**COLOR** Hairline Black **HBK**

### CJP44 basic kit

**Drums:**  
14"x6" bass drum, 8"x5" tom tom, 12"x5.5" floor tom, 10"x5" snare drum, Sound Focus Pad, drum bag, hardware bag.

**Hardware:**  
single tom attachments (x2), single pedal.

### [MCAX5366 clamp kit]

**Hardware:**  
cymbal attachmet & hi-hat attachment pack (sold separately)

## KIT CONFIGURATION LIST

[14"BD 4pc Kit with clamp kit]

CJP44

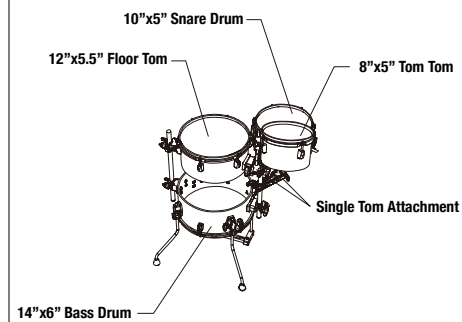

## SPECIFICATIONS

### Shells

All Poplar Shells : 7.5mm, 6ply

Sound Focus Pad

Specially Designed Bags Included

## FINISH (Unicolor Wrap)



Hairline Black  
HBK

NEW





 **TAMA**®



# SNARE DRUMS

TAMA has a wide variety of snare drum options to complement our wide variety of drum kits. TAMA's snare drums are designed for all styles and price points, from ultra-high-end, handmade boutique to basic, no frills workhorse snare drums. Our snare drums represent the opportunity for each drummer to find and expand their own individual artistic expression on this critical drum set voice.

## STAR BUBINGA



Color: Natural Indian Laurel -LNTI

### TBS1465SLNTI MADE IN JAPAN

Please refer to the STAR Bubinga drum kit page to see available sizes, finishes, and inlay options.

Lug: MSL90SC  
Hoop: Die-Cast Hoop (8 hole)  
Strainer/Butt: MLS50A/MLS50B  
Snare Wire: 14"=MS20RL14C,  
13"=MS20RL13C

## STAR MAPLE



Color: Gloss Natural Curly Maple -RGCM

### TMS1465SRGCM MADE IN JAPAN

Please refer to the STAR Maple drum kit page to see available sizes, finishes, and inlay options.

Lug: MSL90SC  
Hoop: Die-Cast Hoop (8 hole)  
Strainer/Butt: MLS50A/MLS50B  
Snare Wire: 14"=MS20RL14C,  
13"=MS20RL13C

## STAR WALNUT



Color: Garnet Japanese Sen Burst - AGJB

### TWS1465AGJB MADE IN JAPAN

Please refer to the STAR Walnut drum kit page to see available sizes and finishes.

Lug: MSL90SC  
Hoop: Die-Cast Hoop (8 hole)  
Strainer/Butt: MLS50A/MLS50B  
Snare Wire: 14"=MS20RL14C,  
13"=MS20RL13C

## STAR SOLID MAPLE



Color: Oiled Natural Maple -OMP

### TLM146SOMP MADE IN JAPAN

Shell: 8mm Solid Maple, w/ 8mm Sound Focus Rings

Size: 14"x6"  
Lug: MSL90SC  
Hoop: Die-Cast Hoop (8 hole)  
Strainer/Butt: MLS50A/MLS50B  
Snare Wire: MS20RL14C  
Color: Oiled Natural Maple (OMP)  
[Inlay Option] Outside Inlay, or w/o Inlay

## STAR SOLID MAHOGANY



Color: Oiled Natural Mahogany -OMH

### TLH146SOMH MADE IN JAPAN

Shell: 7mm Solid Mahogany w/ 7mm Sound Focus Rings  
Size: 14"x6"  
Lug: MSL90SC  
Hoop: Die-Cast Hoop (8 hole)  
Strainer/Butt: MLS50A/MLS50B  
Snare Wire: MS20RL14C  
Color: Oiled Natural Mahogany (OMH)  
[Inlay Option] Outside Inlay, or w/o Inlay

## STAR STAVE WALNUT



Color: Oiled Natural Walnut -OWN

### TWV146SOWN MADE IN JAPAN

Shell: 10mm, 16pcs Stave Walnut  
Size: 14"x6"  
Lug: MSL90SC  
Hoop: Die-Cast Hoop (8 hole)  
Strainer/Butt: MLS50A/MLS50B  
Snare Wire: MS20RL14C  
Color: Oiled Natural Walnut (OWN)  
[Inlay Option] Outside Inlay, or w/o Inlay

## STAR STAVE ASH



Color: Oiled Natural Ash -OAS

### TVA146SOAS MADE IN JAPAN

Shell: 10mm, 16pcs Stave Ash  
Size: 14"x6"  
Lug: MSL90SC  
Hoop: Die-Cast Hoop (8 hole)  
Strainer/Butt: MLS50A/MLS50B  
Snare Wire: MS20RL14C  
Color: Oiled Natural Ash (OAS)  
[Inlay Option] Outside Inlay, or w/o Inlay

## STAR RESERVE SOLID MAPLE



Color: Oiled Natural Maple -OMP

### TLM145SOMP MADE IN JAPAN

Shell: 8mm Solid Maple w/ 8mm Solid Maple Sound Focus Rings  
Size: 14"x5"  
Lug: MTL150  
Hoop: 2.3mm Brass Sound Arc Hoop (8 hole)  
Strainer/Butt: MLS50A / MLS50B  
Snare Wire: MS20L14C8  
Color: Oiled Natural Maple (OMP)

## STAR RESERVE BUBINGA/MAPLE



Color: Caramel Olive Ash Burst -OCOB

### TMB158SOCOB MADE IN JAPAN

Shell: 5.5mm, 8ply Bubinga/Maple (1 inner ply Cordia+2ply Bubinga+4ply Maple+1 outer ply Olive Ash)  
Size: 15"x8"  
Lug: MSL90TC  
Hoop: Brass Mighty Hoop (8 hole)  
Strainer/Butt: MLS50A / MLS50B  
Snare Wire: MS20S115S  
Color: Caramel Olive Ash Burst (OCOB)

## STAR RESERVE WALNUT/BUBINGA



Color: Gloss Claro Walnut -GCW

### TBWS1465SGCW MADE IN JAPAN

Shell: 5.5mm, 4ply Walnut + 2ply Bubinga + 1 outer ply Claro Walnut w/Maple Sound Focus Rings  
Size: 14"x6.5"  
Lug: MTL160  
Hoop: Sound Arc Hoop (10 Hole)  
Strainer/Butt: MLS50A / MLS50B  
Snare Wire: MS20RL14C  
Color: Gloss Claro Walnut (GCW)



## STAR RESERVE HAMMERED COPPER



### TCS1465H

MADE IN JAPAN

Shell: 1.5mm Hammered Copper  
Size: 14"x6.5"  
Lug: MSL90SC  
Hoop: Customized Brass Mighty Hoop (8 Hole)  
Strainer/Butt: MLS50A / MLS50B  
Snare Wire: MS20RL14C

## STAR RESERVE STAVE JATOBA



### TVJ147S0JT

MADE IN JAPAN

Shell: 10mm, 16pcs Stave Jatoba  
Size: 14"x7"  
Lug: MTL160  
Hoop: Die-Cast Hoop (8 Hole)  
Strainer/Butt: MLS50A / MLS50B  
Snare Wire: MS20RL14C  
Color: Oiled Natural Jatoba (OJT)

Color: Oiled Natural Jatoba -OJT

## STAR RESERVE HAMMERED BRASS



### TBR1455H

MADE IN JAPAN

Shell: 1.5mm Hand Hammered Brass  
Size: 14"x5.5"  
Lug: MSL90SC  
Hoop: Customized Brass Mighty Hoop (8 hole)  
Strainer/Butt: MLS50A / MLS50B  
Snare Wire: MS20RL14C

## STAR RESERVE HAMMERED ALUMINUM



### TAS1465H

NEW

MADE IN JAPAN

Shell: 3mm Hand Hammered Aluminum  
Size: 14"x6.5"  
Lug: MSL90SC  
Hoop: Brass Sound Arc Hoop (8 hole)  
Strainer/Butt: MLS50A / MLS50B  
Snare Wire: MS20RL14C

## STARPHONIC MAPLE



### PMM146STM

MADE IN JAPAN

Shell: 6mm, 6ply Maple + 1 Mappa Burl outer ply  
Size: 14"x6"  
Lug: Freedom Lug  
Hoop: Grooved Hoop  
Strainer/Butt: MLS50A/MLS50B  
Snare Wire: MS20RL14C  
Color: Satin Mappa Burl (STM)

Color: Satin Mappa Burl - STM

## STARPHONIC BUBINGA



### PBC146MNC

MADE IN JAPAN

Shell: 7mm, 8ply Bubinga + 1 Cordia outer ply  
Size: 14"x6"  
Lug: Freedom Lug  
Hoop: Grooved Hoop  
Strainer/Butt: MLS50A/MLS50B  
Snare Wire: MS20RL14C  
Color: Matte Natural Cordia (MNC)

Color: Matte Natural Cordia -MNC

## STARPHONIC WALNUT



### PWB147GWB

NEW

MADE IN JAPAN

Shell: 6mm, 6ply American Black Walnut Shell + 1 outer ply Black Walnut Burl  
Size: 14"x7"  
Lug: Freedom Lug  
Hoop: Grooved Hoop  
Strainer/Butt: MLS50A/MLS50B  
Snare Wire: MS20RL14C  
Color: Gloss Black Walnut Burl (GWB)

Color: Gloss Black Walnut Burl -GWB

## STARPHONIC BRASS



### PBR146

MADE IN JAPAN

Shell: 1.2mm Brass  
Size: 14"x6"  
Lug: Freedom Lug  
Hoop: Grooved Hoop  
Strainer/Butt: MLS50A/MLS50B  
Snare Wire: MS20RL14C

## STARPHONIC BELL BRASS



### PBB146

MADE IN JAPAN

Shell: 3mm Bell Brass  
Size: 14"x6"  
Lug: Freedom Lug  
Hoop: Grooved Hoop  
Strainer/Butt: MLS50A/MLS50B  
Snare Wire: MS20RL14C

## STARPHONIC COPPER



### PCP147

MADE IN JAPAN

Shell: 1.2mm Copper  
Size: 14"x7"  
Lug: Freedom Lug  
Hoop: Grooved Hoop  
Strainer/Butt: MLS50A/MLS50B  
Snare Wire: MS20RL14C

## STARPHONIC ALUMINUM



### PAL146

MADE IN JAPAN

Shell: 1.2mm Seamless Aluminum  
Size: 14"x6"  
Lug: Freedom Lug  
Hoop: Grooved Hoop  
Strainer/Butt: MLS50A/MLS50B  
Snare Wire: MS20RL14C

## STARPHONIC STAINLESS STEEL



### PSS146

MADE IN JAPAN

Shell: 1mm Stainless Steel w/ R.S.E.  
Size: 14"x6"  
Lug: Freedom Lug  
Hoop: Grooved Hoop  
Strainer/Butt: MLS50A/MLS50B  
Snare Wire: MS20RL14C

## STARPHONIC STEEL



### PST146

MADE IN JAPAN

Shell: 1mm Steel  
Size: 14"x6"  
Lug: Freedom Lug  
Hoop: Grooved Hoop  
Strainer/Butt: MLS50A/MLS50B  
Snare Wire: MS20RL14C

## STARPHONIC STEEL



### PST137

MADE IN JAPAN

Shell: 1mm Steel  
Size: 13"x7"  
Lug: Freedom Lug  
Hoop: Grooved Hoop  
Strainer/Butt: MLS50A/MLS50B  
Snare Wire: MS20RL13C

## CONCERT SNARE DRUMS - STARPHONIC BRAVURA



Color: Gloss Mocha Brown -GMC

### CMP146MFGMC

MADE IN JAPAN

Shell: 6mm, 7ply 100% Maple  
Size: 6"x14"  
Lug: Freedom Lug  
Hoop: Grooved Straight Hoop (10 hole)  
Strainer: MUS50AC w/Multi Snare Frame  
Butt: MUS50AB w/Multi Snare Frame  
Snare Wire: Nickel Wound Round Guitar String (6 strands)  
Black Nylon Coated Stainless

## CONCERT SNARE DRUMS - STARPHONIC



Color: Gloss Cherry Red -GCR

### CMP146GCR

MADE IN JAPAN

Shell: 6mm, 7ply 100% Maple  
Size: 6"x14"  
Lug: Freedom Lug  
Hoop: Grooved Straight Hoop (10 hole)  
Strainer: MUS50A Linear Drive Strainer  
Butt: MUS50B  
Snare Wire: Hybrid Snare Wire  
Nickel Wound Round Guitar String (6 strands in the center)  
Black Nylon Coated

## STARCLASSIC MAPLE EXOTIC FINISH



Color: Tobacco Sunburst Movingui -VTBV

### MES1465UVTBV

Please refer to the Starclassic Maple Exotic Finishes drum kit page to see available sizes and finishes.

Lug: MSL-SCT  
Hoop: Die-Cast Hoop  
Strainer/Butt: MLS50A/MLS50B  
Snare Wire: 14"=MS20RL14C,  
13"=MS20RL13C

## STARCLASSIC MAPLE LACQUER FINISH



Color: Antique Maple -ATM

### MAS1455ATM

Please refer to the Starclassic Maple Lacquer Finishes drum kit page to see available sizes and finishes. Antique Maple (ATM) is also available.

Lug: MSL-SCT  
Hoop: Die-Cast Hoop  
Strainer/Butt: MLS50A/MLS50B  
Snare Wire: 14"=MS20RL14C,  
13"=MS20RL13C

## STARCLASSIC MAPLE DURACOVER WRAP FINISH



Color: Blue and White Oyster -BWO

### MRS136BWO

Please refer to the Starclassic Maple Duracover Wrap Finishes drum kit page to see available sizes and finishes.

Lug: MSL-SCT  
Hoop: Die-Cast Hoop  
Strainer/Butt: MLS50A/MLS50B  
Snare Wire: 14"=MS20RL14C,  
13"=MS20RL13C

## STARCLASSIC WALNUT/BIRCH LACQUER FINISH



Color: Molten Brown Burst -MBR

### WBSS65MBR

Please refer to the Starclassic Walnut/Birch Lacquer Finishes drum kit page to see available sizes and finishes.

Lug: MSL-SCT  
Hoop: Die-Cast Hoop  
Strainer/Butt: MCS70A/MCS70B  
Snare Wire: 14"=MS20R14S, 13"=MS20R13S

## STARCLASSIC WALNUT/BIRCH DURACOVER WRAP FINISH



Color: Jade Silk -JDL

### WBR65JDL

Please refer to the Starclassic Walnut/Birch Duracover Wrap Finishes drum kit page to see available sizes and finishes.

Lug: MSL-SCT  
Hoop: Die-Cast Hoop  
Strainer/Butt: MCS70A/MCS70B  
Snare Wire: 14"=MS20R14S, 13"=MS20R13S

## S.L.P. BOLD SPOTTED GUM



Color: Satin Natural Spotted Gum -SNG

### LSG1465SNG

Shell: 6mm, 9ply 100% Spotted Gum  
Size: 14"x6.5"  
Lug: MTL60  
Hoop: 2.3mm Steel Mighty Hoops (10 hole)  
Strainer/Butt: MLS50A / MLS50B  
Snare Wire: MS20RL14C  
Color: Satin Natural Spotted Gum (SNG)

## S.L.P. NEW-VINTAGE HICKORY



Color: Satin Vintage Hickory -SVH

### LHK145SVH

Shell: 6mm, 6ply 100% Hickory  
Size: 14"x5"  
Lug: MTL30  
Hoop: 2.3mm Steel Mighty Hoops (8 hole)  
Strainer/Butt: MLS50A / MLS50B  
Snare Wire: MS20RL14C  
Color: Satin Vintage Hickory (SVH)

## S.L.P. G-MAPLE



Color: Kona Mappa Burl -KMB

### LGM146KMB

Shell: 11mm, 12ply Maple + 1 outer ply Mappa Burl  
Size: 14"x6"  
Lug: MSL-SCTBN  
Hoop: Steel Mighty Hoop (10 Hole)  
Strainer/Butt: MLS50ABN / MLS50BBN  
Snare Wire: MS20RL14C  
Color: Kona Mappa Burl (KMB)



## S.L.P. G-MAPLE



Color: Satin Tamo Ash -STA

### LGM137STA

Shell: 10mm, 11ply Maple + 1 outer ply Tamo Ash  
Size: 13"x7"  
Lug: MTL60  
Hoop: Die-Cast Hoop (8 hole)  
Strainer/Butt: MLS50A/MLS50B  
Snare Wire: MS20SN13C  
Color: Satin Tamo Ash (STA)

## S.L.P. G-WALNUT



Color: Matte Black Walnut -MBW

### LGW1465MBW

Shell: 9mm, 10ply Walnut  
Size: 14"x6.5"  
Lug: MTL60  
Hoop: Sound Arc Hoop (10 hole)  
Strainer/Butt: MLS50A/MLS50B  
Snare Wire: MS30R14S  
Color: Matte Black Walnut (MBW)

## S.L.P. DUO BIRCH



Color: Transparent Mocha -TPM

### LBH1410LTPM

Shell: 7mm, 7ply Birch  
Size: 14"x10"  
Lug: MSL-SCT  
Hoop: Sound Arc Hoop (8 hole)  
Strainer/Butt: MCS70A/MCS70B  
Snare Wire: MS20R14S  
Color: Transparent Mocha (TPM)  
\*MTB25E Brackets are equipped.  
\*MFLSL3P Legs are Included.

## S.L.P. DYNAMIC KAPUR



Color: Black Kapur Burst -KPB

### LKP1465KPB

Shell: 5mm, 6ply Kapur  
Size: 14"x6.5"  
Lug: MTL60  
Hoop: Sound Arc Hoop (8 hole)  
Strainer/Butt: MLS50A/MLS50B  
Snare Wire: MS20SN14S  
Color: Black Kapur Burst (KPB), Flat Black (FBK)

## S.L.P. FAT SPRUCE



Color: Wild Satin Spruce -WSS

### LSP146WSS

Shell: 7mm, 8ply Spruce  
Size: 14"x6"  
Lug: MTL60  
Hoop: Die-Cast Hoop (8 hole)  
Strainer/Butt: MLS50A/MLS50B  
Snare Wire: MS20RL14C  
Color: Wild Satin Spruce (WSS), Turquoise (TUQ)

## S.L.P. CLASSIC MAPLE



Color: Super Maple -SMP

### LMP1455SMP

Shell: 7mm, 8ply Maple  
Size: 14"x5.5"  
Lug: MTL50  
Hoop: Sound Arc Hoop (10 hole)  
Strainer/Butt: MLS50A/MLS50B  
Snare Wire: MS20RL14C  
Color: Super Maple (SMP)

## S.L.P. STUDIO MAPLE



Color: Sienna -SEN

### LMP1465FSEN

Shell: 5mm, 6ply Maple w/ Sound Focus Rings  
Size: 14"x6.5"  
Lug: MSL-SCT  
Hoop: 100% Maple Wood Hoop (8 hole)  
Strainer/Butt: MLS50A/MLS50B  
Snare Wire: MS20SN14S  
Color: Sienna (SEN)

## S.L.P. DYNAMIC BRONZE



Color: Super Maple -SMP

### LBZ1445 NEW

Shell: 1.2mm Bronze in Aged finish  
Size: 14"x4.5"  
Lug: MSL-SCPN  
Hoop: Die-Cast Hoop (8 hole)  
Strainer/Butt: MCS70ABN/MCS70BBN  
Snare Wire: MS20SN14C

## S.L.P. SONIC STAINLESS STEEL



Color: Sienna -SEN

### LSS1465

Shell: 1.2mm Stainless Steel  
Size: 14"x6.5"  
Lug: MTL60  
Hoop: 3.0mm Ultimate Steel Mighty Hoops (10 hole)  
Strainer/Butt: MCS70A/MCS70B  
Snare Wire: MS30R14S

## S.L.P. VINTAGE HAMMERED STEEL



Color: Sienna -SEN

### LST1455H

Shell: 1.2mm Hammered Steel  
Size: 14"x5.5"  
Lug: MTL50  
Hoop: Sound Arc Hoop (10 hole)  
Strainer/Butt: MCS70A/MCS70B  
Snare Wire: MS20RL14C

## S.L.P. BLACK BRASS



Color: Sienna -SEN

### LBR1465

Shell: 1.5mm Brass  
Size: 14"x6.5"  
Lug: MSL-SCTBN  
Hoop: Steel Mighty Hoop (10 hole)  
Strainer/Butt: MCS70ABN/MCS70BBN  
Snare Wire: MS42R14S

## S.L.P. BIG BLACK STEEL



Color: Sienna -SEN

### LST148

Shell: 1mm Steel in Matte Black Finish  
Size: 14"x8"  
Lug: MSL35BN  
Hoop: Steel Mighty Hoop (10 hole)  
Strainer/Butt: MCS70ABN/MCS70BBN  
Snare Wire: MS20SN14S

## S.L.P. CLASSIC DRY ALUMINUM



### LAL1455

Shell: 1.2mm Seamless Aluminum  
Size: 14"x5.5"  
Lug: MCHL5S  
Hoop: Steel Mighty Hoop (8 hole)  
Strainer/Butt: MCS70A/MCS70B  
Snare Wire: MS20RL14C

## SOUNDWORKS MAPLE



### DMP1255MVM

Shell: 5mm, 6ply Maple  
Size: 12"x5.5"  
Lug: MSL60S  
Hoop: Sound Arc Hoop (6 hole, 1.6mm)  
Strainer/Butt: MCS70A/MCS70B  
Snare Wire: MS20R12S  
Color: Matte Vintage Maple (MVM)

Color: Matte Vintage Maple -MVM

## SOUNDWORKS MAPLE



### DMP1465MVM

Shell: 5mm, 6ply Maple  
Size: 14"x5.5"  
Lug: MSL60S  
Hoop: Sound Arc Hoop (10 hole)  
Strainer/Butt: MCS70A/MCS70B  
Snare Wire: MS20R14S  
Color: Matte Vintage Maple (MVM)

Color: Matte Vintage Maple -MVM

## SOUNDWORKS KAPUR



### DKP137MRK

Shell: 6mm, 7ply Kapur  
Size: 13"x7"  
Lug: MSL60S  
Hoop: Sound Arc Hoop (8 hole)  
Strainer/Butt: MCS70A/MCS70B  
Snare Wire: MS20R13S  
Color: Matte Brown Kapur (MRK)

Color: Matte Brown Kapur -MRK

## SOUNDWORKS KAPUR



### DKP146MRK

Shell: 6mm, 7ply Kapur  
Size: 14"x6.5"  
Lug: MSL60S  
Hoop: Sound Arc Hoop (10 hole)  
Strainer/Butt: MCS70A/MCS70B  
Snare Wire: MS20R14S  
Color: Matte Brown Kapur (MRK)

Color: Matte Brown Kapur -MRK

## SOUNDWORKS STEEL



### DST1055M

Shell: 1.2mm Steel  
Size: 10"x5.5"  
Lug: MSL60S  
Hoop: Triple Flanged Hoop (6 hole)  
Strainer/Butt: MCS70A/MCS70B  
Snare Wire: MS16R10S  
\*Tom bracket is equipped.  
\*MC69 single tom attachment is included.

## SOUNDWORKS STEEL



### DST1465

Shell: 1.2mm Steel  
Size: 14"x6.5"  
Lug: MSL60S  
Hoop: Steel Mighty Hoop (10 hole)  
Strainer/Butt: MCS70A/MCS70B  
Snare Wire: MS20R14S

## METALWORKS



### BST1055MBK

Shell: 1mm Steel  
Size: 10"x5.5"  
Lug: MSL60SBK  
Hoop: Triple Flanged Hoop (6 hole)  
Strainer/Butt: MUS65ABK/MUS60BBK  
Snare Wire: MS16R10S  
\*Tom bracket is equipped.

## METALWORKS



### BST134BK

Shell: 1mm Steel  
Size: 13"x4"  
Lug: MSL-SCPBK  
Hoop: Triple Flanged Hoop (6 hole)  
Strainer/Butt: MUS65ABK/MUS60BBK  
Snare Wire: MS20R13S

MAP: \$129.99

## METALWORKS



### BST1455BK

Shell: 1mm Steel  
Size: 14"x5.5"  
Lug: MSL60SBK  
Hoop: Triple Flanged Hoop (8 hole)  
Strainer/Butt: MUS65ABK/MUS60BBK  
Snare Wire: MS20R14S

## METALWORKS



### BST1465BK

Shell: 1mm Steel  
Size: 14"x6.5"  
Lug: MSL60SBK  
Hoop: Triple Flanged Hoop (8 hole)  
Strainer/Butt: MUS65ABK/MUS60BBK  
Snare Wire: MS20R14S

## METALWORKS "EFFECT" MINI-TYMP SNARE DRUMS



### BST63MBK

Shell: 1mm Steel  
Size: 6"x3"  
Lug: MSL80TBK  
Hoop: Triple Flanged Hoop (4 hole)  
Snare Wire: Mod Tone System w/ Snare Wire  
\*Tom bracket is equipped.  
\*MC69 single tom attachment is included.



## METALWORKS "EFFECT" MINI-TYMP SNARE DRUMS



### BST83MBK

Shell: 1mm Steel  
 Size: 8"x3"  
 Lug: MSL80TBK  
 Hoop: Triple Flanged Hoop (4 hole)  
 Snare Wire: Mod Tone System w/ Snare Wire  
 \*Tom bracket is equipped.  
 \*MC69 single tom attachment is included.

## METALWORKS "EFFECT" MINI-TYMP SNARE DRUMS



### BST103MBK

Shell: 1mm Steel  
 Size: 10"x3"  
 Lug: MSL80TBK  
 Hoop: Triple Flanged Hoop (6 hole)  
 Snare Wire: Mod Tone System w/ Snare Wire  
 \*Tom bracket is equipped.  
 \*MC69 single tom attachment is included.

## METALWORKS "EFFECT" MINI-TYMP SNARE DRUMS



### BST143MBK NEW

Shell: 1mm Steel  
 Size: 14"x3"  
 Lug: MSL80TBK  
 Hoop: Triple Flanged Hoop (6 hole)  
 Snare Wire: Mod Tone System w/ Snare Wire  
 \*Tom bracket is equipped.  
 \*MC69 single tom attachment is included.

## WOODWORKS



Color: Black Oak Wrap -BOW

### WP1465BKBOW

Shell: 8mm, 8ply Poplar  
 Size: 14"x6.5"  
 Lug: MSL60SBK  
 Hoop: Triple Flanged Hoop (8 hole)  
 Strainer/Butt: MUS65ABK/MUS60BBK  
 Snare Wire: MS20R14S  
 Color: Black Oak Wrap (BOW)

## WOODWORKS



Color: Black Oak Wrap -BOW

### WP148BKBOW

Shell: 8mm, 8ply Poplar  
 Size: 14"x8"  
 Lug: MSL60SBK  
 Hoop: Triple Flanged Hoop (8 hole)  
 Strainer/Butt: MUS65ABK/MUS60BBK  
 Snare Wire: MS20R14S  
 Color: Black Oak Wrap (BOW)

## SIGNATURE PALETTE -KENNY ARONOFF



MADE IN JAPAN

### KA145N

Trackmaster  
 Shell: 1mm Brass  
 Size: 14"x5"  
 Lug: MSL35  
 Hoop: Die-Cast Hoop (10 hole)  
 Strainer/Butt: MSL50A/MLS50B  
 Snare Wire: MS20SN14S

## SIGNATURE PALETTE -KENNY ARONOFF



MADE IN JAPAN

### KA1465

Trackmaster  
 Shell: 1mm Brass  
 Size: 14"x6.5"  
 Lug: MSL35 (Nickel)  
 Hoop: Brass Mighty Hoop (10 hole)  
 Strainer/Butt: MUS80A/MUS80B (Nickel)  
 Snare Wire: MS20SN14S

## SIGNATURE PALETTE -CHARLIE BENANTE



MADE IN JAPAN

### CB1465

Shell: 1.2mm Stainless Steel  
 Size: 14"x6.5"  
 Lug: MSL35BN  
 Hoop: Die-Cast Hoop (10 hole)  
 Strainer/Butt: MUS80ABN/MUS80BBN  
 Snare Wire: MS20SN14S

## SIGNATURE PALETTE -STEWART COPELAND



MADE IN JAPAN

### SC145

Shell: 1.5mm Brass  
 Size: 14"x5"  
 Lug: MSL35  
 Hoop: Die-Cast Hoop (10 hole, Batter side)/Steel  
 Mighty Hoop (10 hole, Snare side)  
 Strainer/Butt: MSL50A/MLS50B  
 Snare Wire: MS20SN14S

## SIGNATURE PALETTE -PETER ERSKINE



MADE IN JAPAN

### PE106M

Shell: 10mm, 12pcs Stave Ash  
 Size: 10"x6"  
 Lug: MSL90SC  
 Hoop: Die-Cast Hoop (6 Hole)  
 Strainer/Butt: MSL50A / MSL50B  
 Snare Wire: MS20SN10S  
 Super Resonant Mounting System Equipped

## SIGNATURE PALETTE -SIMON PHILLIPS



MADE IN JAPAN

### SP125H

The Pageant  
 Shell: 6mm, 7ply Figured Maple w/ 6mm Sound  
 Focus Rings  
 Size: 12"x5"  
 Lug: MSL35H  
 Hoop: Die-Cast Hoop (6 hole, Brushed Nickel)  
 Strainer/Butt: MUS80AH/MUS80BH  
 Snare Wire: MS20S-12S

## SIGNATURE PALETTE -SIMON PHILLIPS



MADE IN JAPAN

### SP1455H

The Gladiator  
 Shell: 1mm Bronze  
 Size: 14"x5.5"  
 Lug: MSL35H  
 Hoop: Brass Mighty Hoop (10 hole, Brushed Nickel)  
 Strainer/Butt: MUS80AH/MUS80BH  
 Snare Wire: MS20S-S

## SIGNATURE PALETTE -SIMON PHILLIPS



### SP1465H

MADE IN JAPAN

The Monarch  
Shell: 6mm, 3ply Figured Maple/3ply  
Bubinga/2ply Maple w/ 6mm Sound Focus Rings  
Size: 14"x6.5"  
Lug: MSL-SCTH  
Hoop: Customized Brass Mighty Hoop (8 hole,  
Brushed Nickel)  
Strainer/Butt: MUS80AH/MUS80BH  
Snare Wire: MS20S-S

## SIGNATURE PALETTE -MIKE PORTNOY



### MP125ST

MADE IN JAPAN

Shell: 1mm Steel (Hammered Matte Black)  
Size: 12"x5"  
Lug: MSL-SCT  
Hoop: Die-Cast Hoop (6 hole)  
Strainer/Butt: MCS100A/MCS70B  
Snare Wire: MS20SN12S

## SIGNATURE PALETTE -MIKE PORTNOY



### MP1455ST

MADE IN JAPAN

Shell: 1mm Steel (Hammered Matte Black)  
Size: 14"x5.5"  
Lug: MSL-SCT  
Hoop: Die-Cast Hoop (8 hole)  
Strainer/Butt: MCS100A/MCS70B  
Snare Wire: MS20SN14S

## SIGNATURE PALETTE -MIKE PORTNOY



### MP1455BU

MADE IN JAPAN

Shell: 8mm, 9ply Bubinga  
Size: 14"x5.5"  
Lug: MSL-SCT  
Hoop: Die-Cast Hoop (8 hole)  
Strainer/Butt: MCS100A/MCS70B  
Snare Wire: MS20SN14S

## SIGNATURE PALETTE -JOHN TEMPESTA



### JT147

MADE IN JAPAN

Shell: 2mm Brass  
Size: 14"x7"  
Lug: MSL-SCTBN  
Hoop: Die-Cast Hoop (10 hole)  
Strainer/Butt: MUS80ABN/MUS80BBN  
Snare Wire: MS42R14S

## SIGNATURE PALETTE -LARS ULRICH



### LU1465N

MADE IN JAPAN

Shell: 3mm Diamond Plate Steel  
Size: 14"x6.5"  
Lug: MSL35  
Hoop: Die-Cast Hoop (10 hole)  
Strainer/Butt: MUS80A/MUS80B  
Snare Wire: MS20SN14S

## SIGNATURE PALETTE -RONALD BRUNER JR.



### RB1455

Shell: 6mm 6ply Walnut + 1mm Steel  
Size: 14"x5.5"  
Lug: MSL-SCT in Matte Black Finish  
Hoop: Die-Cast Hoop (10 hole) in Matte Black  
Finish  
Strainer/Butt: MLS50A/MLS50B in Matte Black  
Finish  
Snare Wire: MS20RL14C

# DRUM PEDALS

Our Iron Cobra pedals have long been praised for being smooth, reliable, and independently adjustable. Iron Cobra pedals are offered in the high end 900 series as well as the standard 600 and 200 models. Speed Cobra 910 and 310 drum pedals feature a longer footboard for a lighter, quicker feel. Our drum pedal range is designed to fit the needs of every drummer.

## DYNA-SYNC SINGLE PEDAL



### HPDS1

- Optimized Transmission Design
- Dual Linkage
- Slidable Cam
- Footboard Angle Adjustment
- Dyna Beater
- Swivel Spring Tight
- Speedo-Ring
- Oiles Bearing Hinge
- Para-Clamp II Pro
- Sync-Coil
- Hinge Guard Block
- Hardshell Carrying Case

## DYNA-SYNC TWIN PEDAL



### HPDS1TW

- Optimized Transmission Design
- Dual Linkage
- Slidable Cam
- Footboard Angle Adjustment
- Dyna Beater
- Swivel Spring Tight
- Speedo-Ring
- Oiles Bearing Hinge
- Para-Clamp II Pro
- Sync-Coil
- Hinge Guard Block
- Hardshell Carrying Case

## SPEED COBRA 910 SINGLE PEDAL



### HP910LN

- Long Footboard
- Recessed Setting
- Rolling Glide LiteSprocket Cam
- Accu-Strike Cobra Beater
- Swivel Spring Tight
- Super Stabilizer Design
- Para-Clamp II Pro
- Cobra Coil
- Hinge Guard Block
- Hardshell Carrying Case

## SPEED COBRA 910 TWIN PEDAL



### HP910LWN

- Long Footboard
- Recessed Setting
- Rolling Glide LiteSprocket Cam
- Accu-Strike Cobra Beater
- Swivel Spring Tight
- Super Stabilizer Design
- Para-Clamp II Pro
- Cobra Coil
- Hinge Guard Block
- Hardshell Carrying Case

## SPEED COBRA 910 TWIN PEDAL



### HP910LWLN

- Left-Footed
- Long Footboard
- Recessed Setting
- Rolling Glide LiteSprocket Cam
- Accu-Strike Cobra Beater
- Swivel Spring Tight
- Super Stabilizer Design
- Para-Clamp II Pro
- Cobra Coil
- Hinge Guard Block
- Hardshell Carrying Case

## IRON COBRA 900 SINGLE PEDAL -POWER GLIDE-



### HP900PN

- Power Glide LiteSprocket Cam
- Power-Strike Cobra Beater
- Swivel Spring Tight
- Super Stabilizer Design
- Para-Clamp II Pro
- Cobra Coil
- Hinge Guard Block
- Hardshell Carrying Case

## IRON COBRA 900 TWIN PEDAL -POWER GLIDE-



### HP900PWN

- Power Glide LiteSprocket Cam
- Power-Strike Cobra Beater
- Swivel Spring Tight
- Super Stabilizer Design
- Para-Clamp II Pro
- Cobra Coil
- Hinge Guard Block
- Hardshell Carrying Case

## IRON COBRA 900 TWIN PEDAL -POWER GLIDE-



### HP900PWLN

- Left-Footed
- Power Glide LiteSprocket Cam
- Power-Strike Cobra Beater
- Swivel Spring Tight
- Super Stabilizer Design
- Para-Clamp II Pro
- Cobra Coil
- Hinge Guard Block
- Hardshell Carrying Case

## IRON COBRA 900 SINGLE PEDAL -ROLLING GLIDE-



### HP900RN

- Rolling Glide LiteSprocket Cam
- Power-Strike Cobra Beater
- Swivel Spring Tight
- Super Stabilizer Design
- Para-Clamp II Pro
- Cobra Coil
- Hinge Guard Block
- Hardshell Carrying Case

## IRON COBRA 900 TWIN PEDAL -ROLLING GLIDE-



### HP900RWN

- Rolling Glide LiteSprocket Cam
- Power-Strike Cobra Beater
- Swivel Spring Tight
- Super Stabilizer Design
- Para-Clamp II Pro
- Cobra Coil
- Hinge Guard Block
- Hardshell Carrying Case

## IRON COBRA 600 SINGLE PEDAL -DUO GLIDE-



### HP600D

- Duo Glide
- Double Chain Drive
- Speedo-Ring
- Para-Clamp
- Spring Tension Adjustment
- Beater Angle Adjustment
- Dual Sided Beater

## IRON COBRA 600 TWIN PEDAL -DUO GLIDE-



### HP600DTW

- Duo Glide
- Double Chain Drive
- Speedo-Ring
- Para-Clamp
- Spring Tension Adjustment
- Beater Angle Adjustment
- Dual Sided Beater

## SPEED COBRA 310 SINGLE PEDAL



### HP310L

- Long Footboard
- Recessed Setting
- Rolling Glide LiteSprocket
- Double Chain Drive
- Spring Tension Adjustment
- Beater Angle Adjustment
- Dual Sided Beater

## SPEED COBRA 310 TWIN PEDAL



### HP310LW

- Long Footboard
- Recessed Setting
- Rolling Glide LiteSprocket
- Double Chain Drive
- Spring Tension Adjustment
- Beater Angle Adjustment
- Dual Sided Beater

## IRON COBRA 200 SINGLE PEDAL



### HP200P

- Power Glide
- Spring Tension Adjustment
- Beater Angle Adjustment
- Dual Sided Beater

## IRON COBRA 200 TWIN PEDAL



### HP200PTW

- Power Glide
- Spring Tension Adjustment
- Beater Angle Adjustment
- Dual Sided Beater

## IRON COBRA 200 TWIN PEDAL



### HP200PTWL

- Left-Footed
- Power Glide
- Spring Tension Adjustment
- Beater Angle Adjustment
- Dual Sided Beater

## STANDARD SINGLE PEDAL



### HP30

- Power Glide
- Spring Tension Adjustment
- Beater Angle Adjustment
- Dual Sided Beater



## THE CLASSIC PEDAL



### HP50

- Center Strike Height Adjust
- Easy Access Spring Adjustment
- The Classic Beater
- Smooth Surface Footboard
- Individual Adjustment of Beater & Footboard Angle
- Easy-Tight Hoop Clamp
- Compact Folding Design

## TWIN PEDAL ATTACHMENT



### TPA90

Specially designed attachment to connect Speed Cobra 910 and Iron Cobra 900 series pedals with Speed Cobra 910 and Iron Cobra 900 series Hi-hat stands.

# HI-HAT STANDS

In addition to bass drum pedals, we offer various hi-hat stands including our high end Dyna-Sync, Iron Cobra & Speed Cobra models as well as our standard Stage Master models.

## DYNA-SYNC HI-HAT STAND



### HHDS1

- Direct Drive Action
- Spring Damper for Reducing Noise
- Quick-Set Hi-Hat Clutch
- 6-way Tension Adjustment
- Footboard Angle Adjustment
- Bigger Rubber Feet w/Duo-Spike
- Weight: 5.2kg (11.7lbs)
- Height Adjustment Range: 745mm-960mm (29 3/8" - 37 3/4") (Standard Rod) / 745mm-810mm (29 3/8" - 31 7/8") (Short Rod)

## SPEED COBRA 910 HI-HAT STAND - LEVER GLIDE



### HH915D

- Spring Seat
- Quick-Set Hi-Hat Clutch
- 6-way Tension Adjustment
- Bigger Rubber Feet w/Duo-Spike
- Weight: 5.2kg (11.7lbs)
- Height Adjustment Range: 745mm-960mm (29 3/8" - 37 3/4") (Standard Rod) / 745mm-810mm (29 3/8" - 31 7/8") (Short Rod)

## IRON COBRA 900 HI-HAT STAND -LEVER GLIDE



### HH905D

- Spring Seat
- Quick-Set Hi-Hat Clutch
- 6-way Tension Adjustment
- Bigger Rubber Feet w/Duo-Spike
- Weight: 5.2kg (11.7lbs)
- Height Adjustment Range: 745mm-960mm (29 3/8" - 37 3/4") (Standard Rod) / 745mm-810mm (29 3/8" - 31 7/8") (Short Rod)

## IRON COBRA 900 HI-HAT STAND -VELO GLIDE



### HH805D

- Spring Seat
- Quick-Set Hi-Hat Clutch
- 6-way Tension Adjustment
- Bigger Rubber Feet w/Duo-Spike
- Weight: 5.2kg (11.7lbs)
- Height Adjustment Range: 745mm-960mm (29 3/8" - 37 3/4") (Standard Rod) / 745mm-810mm (29 3/8" - 31 7/8") (Short Rod)

## IRON COBRA 900 REMOTE HI-HAT STAND



### HH905RH

- JAGWIRE™ Triple-Layered Ultra-Smooth Cable
- Quick-Set Hi-Hat Clutch
- Lever Glide
- 6-way Tension Adjustment
- MC66 Universal Clamp
- Ratchet Arm ( 12mm, Arm Length: 200mm)
- Dual Leg
- Cable Holders (x 6)
- Carrying Bag
- Weight: 8.1kg (17lbs)

## IRON COBRA 600 HI-HAT STAND



### HH605

- Spring Seat
- Swing Lock Clutch
- 6-way Tension Adjustment
- Swivel Foot
- Direct Pull Action
- Footboard Angle Adjustment
- Weight: 4.3kg (9.7lbs)
- Height Adjustment Range: 710mm-930mm (28" - 36 5/8")

## SPEED COBRA 310 HI-HAT STAND



### HH315D

- Dual Leg
- 28.6mm Diameter Base Section Tubing
- Security Clutch
- 6-way Tension Adjustment
- Swivel Foot
- Direct Pull Action
- Weight: 3.9kg (8.9lbs)
- Height Adjustment Range: 710mm-930mm (28" - 36 5/8")

## IRON COBRA 200 HI-HAT STAND



### HH205

- Double Braced Legs
- 5-way Tension Adjustment
- Swivel Foot
- Direct Pull Action
- Non-Loosening Tension Rod
- Toe Guard
- Security Clutch
- Weight: 3.8kg (8.6lbs)
- Height Adjustment Range: 670mm-930mm (26 3/8" - 36 5/8")

## IRON COBRA 200 HI-HAT STAND



### HH205S

- Single Braced Legs
- 5-way Tension Adjustment
- Swivel Foot
- Direct Pull Action
- Non-Loosening Tension Rod
- Toe Guard
- Security Clutch
- Weight: 3.1kg (6.8lbs)
- Height Adjustment Range: 670mm-930mm (26 3/8" - 36 5/8")

## STAGE MASTER HI-HAT STAND



### HH45WN

- Double Braced Legs
- Swivel Foot
- Direct Pull Action
- Non-Loosening Tension Rod
- Toe Guard
- Security Clutch
- Weight: 3.4kg (7.6lbs)
- Height Adjustment Range: 670mm-930mm (26 3/8" - 36 5/8")

## STAGE MASTER HI-HAT STAND



### HH45SN

- Single Braced Legs
- Swivel Foot
- Direct Pull Action
- Non-Loosening Tension Rod
- Toe Guard
- Security Clutch
- Weight: 3.0kg (6.7lbs)
- Height Adjustment Range: 670mm-930mm (26 3/8" - 36 5/8")

## THE CLASSIC HI-HAT STAND



### HH55F

- Single Braced Flat Base Tripod Legs
- Individual Adjustment of Spring Tension & Footboard Angle
- Knurling on Base Pipe
- Memory Lock
- Weight: 2.3kg (5.1 lbs)
- Height Adjustment Range: 650mm-950mm (24 5/8" - 37 3/8")
- Storage size: 500mm (19 11/16") (upper section) / 600mm (23 5/8") (lower section)

# DRUM THRONES

Being comfortable on your drum set is one of the most important aspects of drumming, making the drum throne a vital yet often overlooked piece of equipment. Our ergonomic 1st Chair Drum Thrones have many original TAMA features to guarantee comfort, stability, and quick, easy setup.

## 1ST CHAIR ROUND RIDER XL DRUM THRONE -CLOTH TOP



### HT850BC

- Round Rider XL Seat
- 15" Diameter, 130mm (5 1/8") Thick Round Seat
- 1st Chair Height Adjustment
- Seat Lock
- Glide-Tite Grip Joint
- Rocklok
- Oversized Rubber Feet
- Foot Life
- Weight: 6.0kg (13.3lbs)
- Height Adjustment Range: 515mm - 695mm (21 1/4" - 27 3/8")

## 1ST CHAIR ROUND RIDER XL DRUM THRONE



### HT830R

- Round Rider XL Seat
- 15" Diameter, 130mm (5 1/8") Thick Round Seat
- 1st Chair Height Adjustment
- Seat Lock
- Glide-Tite Grip Joint
- Rocklok
- Oversized Rubber Feet
- Foot Life
- Weight: 6.0kg (13.3lbs)
- Height Adjustment Range: 515mm - 670mm (21 1/4" - 26 3/8")

## 1ST CHAIR ROUND RIDER XL DRUM THRONE



### HT830B

Round Rider XL Seat  
-15" Diameter, 130mm (5 1/8") Thick Round Seat  
-1st Chair Height Adjustment  
-Seat Lock  
-Glide-Tite Grip Joint  
-Rocklok  
-Oversized Rubber Feet  
-Foot Life  
-Weight: 6.0kg (13.3lbs)  
-Height Adjustment Range: 515mm - 670mm (21 1/4" - 26 3/8")

## 1ST CHAIR ERGO-RIDER DRUM THRONE -CLOTH TOP



### HT750BC

Ergo-Rider "Cloth Top" Seat  
-HYDRAULIX  
-Seat Lock  
-Oversized Rubber Feet  
-Foot Life  
-Weight: 6.1kg (13.7lbs)  
Height Adjustment Range: 505mm - 685mm (19 7/8" - 27")

## 1ST CHAIR ERGO-RIDER DRUM THRONE



### HT730B

Ergo-Rider Seat  
-1st Chair Height Adjustment  
-Seat Lock  
-Glide-Tite Grip Joint  
-Rocklok  
-Oversized Rubber Feet  
-Foot Life  
-Weight: 6.1kg (13.7lbs)  
-Height Adjustment Range: 505mm - 660mm (19 7/8" - 26")

## 1ST CHAIR ERGO-RIDER DRUM THRONE -QUARTET



### HT741B

Ergo-Rider Seat  
-1st Chair Height Adjustment  
-Seat Lock  
-Backrest  
-Glide-Tite Grip Joint  
-Rocklok  
-Oversized Rubber Feet  
-Foot Life  
-Weight: 9.4kg (20.1lbs)  
-Height Adjustment Range: 515mm - 665mm (20 1/4" - 26 3/6")

## 1ST CHAIR GLIDE RIDER DRUM THRONE -CLOTH TOP



### HT550BCN

Glide Rider "Cloth Top" Seat  
-HYDRAULIX  
-Seat Lock  
-Glide-Tite Grip Joint  
-Rocklok  
-Oversized Rubber Feet  
-Foot Life  
-Weight: 5.9kg (13lbs)  
-Height Adjustment Range: 470mm - 650mm (18 1/2" - 24 5/8")

## 1ST CHAIR GLIDE RIDER DRUM THRONE -CLOTH TOP



### HT530BCN

Glide Rider "Cloth Top" Seat  
-1st Chair Height Adjustment  
-Seat Lock  
-Glide-Tite Grip Joint  
-Rocklok  
-Oversized Rubber Feet  
-Foot Life  
-Weight: 5.9kg (13lbs)  
-Height Adjustment Range: 470mm - 650mm (18 1/2" - 24 5/8")

## 1ST CHAIR ROUND RIDER DRUM THRONE -CLOTH TOP



### HT430BC

Round Rider "Cloth Top" Seat  
-14" Diameter, 120mm (4 3/4") Thick Round Seat  
-1st Chair Height Adjustment  
-Seat Link  
-Rocklok  
-Foot Life  
-Weight: 5.3kg (11.1lbs)  
-Height Adjustment Range: 485mm - 655mm (19" - 25 3/4")

## 1ST CHAIR ROUND RIDER DRUM THRONE



### HT430B

Round Rider Seat  
-14" Diameter, 120mm (4 3/4") Thick Round Seat  
-1st Chair Height Adjustment  
-Seat Link  
-Rocklok  
-Foot Life  
-Weight: 5.3kg (11.1lbs)  
-Height Adjustment Range: 485mm - 655mm (19" - 25 3/4")

## 1ST CHAIR SADDLE-TYPE DRUM THRONE



### HT250

Saddle-Type Seat  
-1st Chair Height Adjustment  
-Glide-Tite Grip Joint  
-Rocklok  
-Foot Life  
-Weight: 4.05kg (8.9lbs)  
-Height Adjustment Range: 425mm - 625mm (16 3/4" - 24 1/2")

## 1ST CHAIR ROUNDED TYPE DRUM THRONE



### HT230

Rounded Seat  
-1st Chair Height Adjustment  
-Glide-Tite Grip Joint  
-Rocklok  
-Foot Life  
-Weight: 4.0kg (8.8lbs)  
-Height Adjustment Range: 460mm - 660mm (18" - 26")

## STANDARD DRUM THRONE



### HT130

- 13" Diameter, 90mm (3 1/2") Thick Round Seat
- Double Braced Legs
- Weight: 3.4kg (7.7lbs)
- Height Adjustment Range: 445mm - 620mm (17 1/2" - 24 7/16")

## SNARE STANDS

Our STAR snare stand has several unique features which provide the ultimate solution for a flexible and stable snare drum setup. Our Roadpro stands now have greater stability, in addition to Quick-Set universal tilters.

### STAR HARDWARE SNARE STAND



#### HS100W

- For 12" to 15" Diameter Snare Drums
- 28.6mm Diameter Base Section Tubing
- Cradle-Hold Snare Basket
- Glide-Tite Grip Joint
- True-Sound Insulation Mute
- Oversized Rubber Feet with Retractable Spike
- Weight: 3.9kg (8.9lbs)
- Height Adjustment Range: 400mm - 600mm (15 3/4" - 23 5/8")

### ROADPRO SNARE STAND



#### HS800W

- For 12" to 15" Diameter Snare Drums
- 28.6mm Diameter Base Section Tubing
- Omni-Ball Tilter
- Swiveling Basket
- Glide-Tite Grip Joint
- Double Braced Legs
- Weight: 3.4kg (7.7lbs)
- Height Adjustment Range: 495mm - 665mm (19 1/2" - 26 3/8")

### ROADPRO SNARE STAND



#### HS80W

- For 12" to 15" Diameter Snare Drums
- 28.6mm Diameter Base Section Tubing
- Quick-Set Tilter
- Swiveling Basket
- Glide-Tite Grip Joint
- Double Braced Legs
- Weight: 3.2kg (7lbs)
- Height Adjustment Range: 495mm - 640mm (19 1/2" - 25 3/16")

### ROADPRO SNARE STAND



#### HS80PW

- For 10" to 12" Diameter Snare Drums
- 28.6mm Diameter Base Section Tubing
- Quick-Set Tilter
- Swiveling Basket
- Glide-Tite Grip Joint
- Double Braced Legs
- Weight: 3.2kg (7lbs)
- Height Adjustment Range: 465mm - 610mm (18 5/16" - 24")

### ROADPRO SNARE STAND



#### HS80LOW

- For 12" to 15" Diameter Snare Drums
- 28.6mm Diameter Base Section Tubing
- Low Position Setting Basket
- Quick-Set Tilter
- Glide-Tite Grip Joint
- Double Braced Legs
- Weight: 3.3kg (7.4lbs)
- Height Adjustment Range: 385mm - 530mm (15 3/16" - 20 7/8")

### CONCERT SNARE STAND - ROADPRO



#### HS80HWN

- For 12" to 15" Diameter Snare Drums
- Quick-Set Tilter
- Swiveling Basket
- Glide-Tite Grip Joint
- Double Braced Legs
- Weight: 3.7kg (8.2lbs)
- Height Adjustment Range: 640mm - 925mm (25 3/16" - 36 3/8")



## 60 SERIES SNARE STAND



### HS60W

For 12" to 15" Diameter Snare Drums  
-25.4mm Diameter Base Section Tubing  
-Quick-Set Tilter  
-Swiveling Basket  
-Double Braced Legs  
-Weight: 2.6kg (5.1lbs)  
-Height Adjustment Range: 470mm - 600mm (18 1/2" - 23 5/8")

## STAGE MASTER SNARE STAND



### HS40WN

For 12" to 15" Diameter Snare Drums  
-25.4mm Diameter Base Section Tubing  
-Universal Gearless Tilter  
-Swiveling Basket  
-Double Braced Legs  
-Weight: 2.6kg (5.11lbs)  
-Height Adjustment Range: 470mm - 630mm (18 1/2" - 24 13/16")

## STAGE MASTER SNARE STAND



### HS40SN

For 12" to 15" Diameter Snare Drums  
-25.4mm Diameter Base Section Tubing  
-Universal Gearless Tilter  
-Swiveling Basket  
-Single Braced Legs  
-Weight: 2.5kg (5.8lbs)  
-Height Adjustment Range: 470mm - 630mm (18 1/2" - 24 13/16")

## STAGE MASTER SNARE STAND



### HS40LOWN

For 12" to 15" Diameter Snare Drums  
-25.4mm Diameter Base Section Tubing  
-Low Position Setting Basket  
-Universal Gearless Tilter  
-Double Braced Legs  
-Weight: 2.7kg (5.15lbs)  
-Height Adjustment Range: 370mm - 530mm (14 9/16" - 20 7/8")

## THE CLASSIC SNARE STAND



### HS50S

For 12" to 15" Diameter Snare Drums  
-19.1mm Diameter Base Section Tubing  
-Single Braced Tripod Legs  
-Classic Style Basket  
-Double Braced Arms  
-Gearless Tilter  
-Memory Lock  
-Weight: 1.7kg (3.11lbs)  
-Height Adjustment Range: 390mm-580mm (15 3/8" - 22 7/8")  
-Storage size: 600mm (23 5/8")

## CONCERT SNARE STAND - THE CLASSIC STAND



### HS50HF

-Flat Base Leg Design  
-Classic Style Basket  
-Double Braced Arms  
-Gearless Tilter  
-Weight: 1.9kg (4.2lbs)  
-Height Adjustment Range: 630mm-860mm (24 13/16" - 33 7/8")

# CYMBAL STANDS

The TAMA STAR Hardware cymbal stand is incredibly flexible with several groundbreaking adjustment features. The Roadpro cymbal stands benefit from greater stability, and include the same great Quick-Set Tilter and Quick-Set Cymbal Mates.

## STAR HARDWARE CYMBAL STAND



### HC103BW

-28.6mm Diameter Base Section Tubing  
-Orbital Quick-Tite Cymbal/Boom Tilter  
-Glide-Tite Grip Joint  
-True-Sound Insulation Mute  
-Ring-True Cymbal Felt  
-Boom Arm Length: 450mm (17 3/4")  
-Weight: 6.1kg (13.7lbs)  
-Height Adjustment Range: 890mm - 2,090mm (35" - 82 1/4")

## ROADPRO CYMBAL STAND



### HC84BW

-28.6mm Diameter Base Section Tubing  
-Quick-Set Tilter  
-Quick-Set Cymbal Mate  
-Boom/Straight Convertible Tilter  
-Glide-Tite Grip Joint  
-Detachable Counter Weight  
-Boom Arm Length : 688mm (27 3/32")  
-Weight : 6.2kg (13.10lbs)  
-Height Adjustment Range: 820mm - 2,200mm (32 1/4" - 86 5/8")

## ROADPRO CYMBAL STAND



### HC83BW

- 28.6mm Diameter Base Section Tubing
- Quick-Set Tilter
- Quick-Set Cymbal Mate
- Boom/Straight Convertible Tilter
- Glide-Tite Grip Joint
- Double Braced Legs
- Boom Arm Length: 450mm (17 3/4")
- Weight: 5.0kg (11lbs)
- Height Adjustment Range: 820mm - 2,100mm (32 1/4" - 82 5/8")

## ROADPRO CYMBAL STAND



### HC82W

- 28.6mm Diameter Base Section Tubing
- Quick-Set Tilter
- Quick-Set Cymbal Mate
- Glide-Tite Grip Joint
- Double Braced Legs
- Weight: 4.2kg (9.4lbs)
- Height Adjustment Range: 740mm - 1,610mm (31 1/8" - 72 7/8")

## ROADPRO LIGHT CYMBAL STAND



### HC83BLS

- 25.4mm Diameter Base Section Tubing
- Quick-Set Tilter
- Quick-Set Cymbal Mate
- Boom/Straight Convertible Tilter
- Glide-Tite Grip Joint
- Single Braced Legs
- Boom Arm Length: 400mm (15 3/4")
- Weight: 3.8kg (8.6lbs)
- Height Adjustment Range: 790mm - 1,850mm (31 1/8" - 72 7/8")

## ROADPRO LIGHT CYMBAL STAND



### HC82LS

- 25.4mm Diameter Base Section Tubing
- Quick-Set Tilter
- Quick-Set Cymbal Mate
- Glide-Tite Grip Joint
- Single Braced Legs
- Weight: 3.1kg (6.13lbs)
- Height Adjustment Range: 710mm - 1,410mm (28" - 55 1/2")

## 60 SERIES CYMBAL STAND



### HC63BW

- 25.4mm Diameter Base Section Tubing
- Quick-Set Tilter
- Boom/Straight Convertible Tilter
- Double Braced Legs
- Boom Arm Length: 400mm (15 3/4")
- Weight: 3.9kg (8.9lbs)
- Height Adjustment Range: 850mm - 2,010mm (33 1/2" - 79 1/8")

## STAGE MASTER CYMBAL STAND



### HC43BWN

- 25.4mm Diameter Base Section Tubing
- Fine Gear Tilter
- Quick-Set Cymbal Mate
- Boom/Straight Convertible Tilter
- Double Braced Legs
- Boom Arm Length: 400mm (15 3/4")
- Weight: 3.4kg (7.5lbs)
- Height Adjustment Range: 760mm - 1,800mm (30" - 70 13/16")

## STAGE MASTER CYMBAL STAND



### HC43BSN

- 25.4mm Diameter Base Section Tubing
- Fine Gear Tilter
- Quick-Set Cymbal Mate
- Boom/Straight Convertible Tilter
- Single Braced Legs
- Boom Arm Length: 400mm (15 3/4")
- Weight: 3.4kg (7.7lbs)
- Height Adjustment Range: 760mm - 1,800mm (30" - 70 13/16")

## STAGE MASTER CYMBAL STAND



### HC42WN

- 25.4mm Diameter Base Section Tubing
- Fine Gear Tilter
- Quick-Set Cymbal Mate
- Double Braced Legs
- Weight: 2.9kg (6.6lbs)
- Height Adjustment Range: 690mm - 1,420mm (27 1/8" - 55 15/16")

## STAGE MASTER CYMBAL STAND



### HC42SN

- 25.4mm Diameter Base Section Tubing
- Fine Gear Tilter
- Quick-Set Cymbal Mate
- Single Braced Legs
- Weight: 2.7kg (5.15lbs)
- Height Adjustment Range: 690mm - 1,420mm (27 1/8" - 55 15/16")

## THE CLASSIC CYMBAL STAND



### HC52F

- 19.1mm Diameter Base Section Tubing
- Flat Base Leg Design
- 9mm Diameter Solid Upper Portion
- Fine Gear Tilter
- Compact Folding Design (580mm 22 27/32")
- Weight: 1.48kg (3.2lbs)
- Height Adjustment Range: 590mm - 1,300mm (23 1/4" - 51 3/16")

# TOM STANDS & TOM HOLDERS

TAMA's tom stands and tom holders feature our original Omni-Ball system which allows each tom to be held securely in place. You can position the drum at virtually any angle simply by loosening one T-nut.

## STAR HARDWARE COMBINATION STAND



### HTC107W

- 28.6mm Diameter Base Section Tubing
- Swivel-Wing Tom Holder
- Orbital Quick-Tite Cymbal Tilter
- Orbital Quick-Tite Boom Tilter
- Glide-Tite Grip Joint
- True-Sound Insulation Mute
- Ring-True Cymbal Felt
- Boom Arm Length: 300mm (11 3/4")
- Weight: 7.2kg (15.13lbs)

## STAR HARDWARE DOUBLE TOM STAND



### HTW109W

- 28.6mm Diameter Base Section Tubing
- Swivel-Wing Tom Holder
- Stilt System
- Glide-Tite Grip Joint
- Extra Heavy Double Braced Legs
- Weight: 6.0kg (13lbs)

## STAR HARDWARE SINGLE TOM STAND



### HTS108W

- For up to 10" Depth Tom Tom
- 28.6mm Diameter Base Section Tubing
- Omni-Ball Tilter
- Glide-Tite Grip Joint
- True-Sound Insulation Mute
- Extra Heavy Double Braced Legs
- Oversized Rubber Feet with Retractable Spike
- Weight: 4.3kg (9.7lbs)

## ROADPRO COMBINATION STAND



### HTC807W

- 28.6mm Diameter Base Section Tubing
- Omni-Ball Tom Angle Adjustment / Movable Tom Positioning
- Quick-Set Tilter
- Quick-Set Cymbal Mate
- Glide-Tite Grip Joint
- Double Braced Legs
- Boom Arm Length: 300mm (11 3/4")
- Weight: 5.4kg (11.14lbs)

## ROADPRO COMBINATION STAND



### HTC87W

- 28.6mm Diameter Base Section Tubing
- Omni-Ball Tom Angle Adjustment
- Quick-Set Tilter
- Quick-Set Cymbal Mate
- Glide-Tite Grip Joint
- Double Braced Legs
- Boom Arm Length: 300mm (11 3/4")
- Weight: 5.5kg (12.2lbs)

## ROADPRO DOUBLE TOM STAND



### HTW839W

- 28.6mm Diameter Base Section Tubing
- Omni-Ball Tom Angle Adjustment
- Stilt System
- Glide-Tite Grip Joint
- Double Braced Legs
- Weight: 5.0kg (11lbs)

## ROADPRO DOUBLE TOM STAND



### HTW849W

- 28.6mm Diameter Base Section Tubing
- Omni-Ball Tom Angle Adjustment
- Glide-Tite Grip Joint
- Double Braced Legs
- Low Profile Tetrapod
- Weight: 5.1kg (11.3lbs)

## STAGE MASTER DOUBLE TOM STAND



### HTW49WN

- 25.4mm Diameter Base Section Tubing
- Omni-Ball Tom Angle Adjustment
- Double Braced Legs
- Weight: 3.6kg (7.14lbs)

## THE CLASSIC TOM STAND



### HTS58F

For 10" to 14" Diameter Drums  
-19.1mm Diameter Base Section Tubing  
-Flat Base Leg Design  
-Classic Style Basket  
-Memory Lock  
-Weight: 1.8kg (3.15lbs)  
-Height Adjustment Range: 565mm - 820mm (22 1/4" - 32 1/4")  
-Storage size: 600mm (23 5/8") (upper section) / 410mm (16 1/8") (lower section)

## DOUBLE TOM HOLDER



### MTH1000

-25.4mm Diameter Bass Section Tubing  
-Swivel-Wing Tom Holder

MTH1000 (chrome)  
MTH1000BN (black nickel)  
MTH1000U (smoked black nickel)

## DOUBLE TOM HOLDER



### MTH905N

-25.4mm Diameter Tubing  
-Sliding Tom Adjustment

## DOUBLE TOM HOLDER



### MTH800

-25.4mm Diameter Tubing

**NEW**

## DOUBLE TOM HOLDER



### MTH600

-25.4mm Diameter Tubing

MTH600 (chrome)  
MTH600BN (black nickel)

## SINGLE TOM HOLDER



### MTH1000S

-25.4mm Diameter Bass Section Tubing  
-Swivel-Wing Tom Holder

MTH1000S (chrome)  
MTH1000SBN (black nickel)  
MTH1000SU (smoked black nickel)

## SINGLE TOM HOLDER



### MTH900BS

-25.4mm Diameter Bass Section Tubing

## SINGLE TOM HOLDER



### MTH900BM

-25.4mm Diameter Tubing



# HARDWARE KITS

We offer various hardware kit packages to complement any drum sets.

## IRON COBRA 900 HARDWARE KIT



### HG5WN

- HS800W Roadpro Snare Stand
- HC83BW Roadpro Boom Cymbal Stands (x2)
- HH905D Iron Cobra Hi-hat Stand
- HP900PN Iron Cobra Power Glide Single Pedal

## IRON COBRA 600 HARDWARE KIT



### HV5WN

- HS80W Roadpro Snare Stand
- HC83BW Roadpro Boom Cymbal Stands (x2)
- HH605 Iron Cobra 600 Hi-hat Stand
- HP600D Iron Cobra 600 Single Pedal

## IRON COBRA 200 HARDWARE KIT



### HB5W

- HS60W Snare Stand
- HC63BW Boom Cymbal Stands (x2)
- HH205 Iron Cobra 200 Hi-hat Stand
- HP200P Iron Cobra 200 Single Pedal

## STAGE MASTER HARDWARE KIT



### SM5W

- HS40WN Stage Master Snare Stand
- HC43BWN Stage Master Boom Cymbal Stands (x2)
- HH205 Iron Cobra 200 Hi-hat Stand
- HP200P Iron Cobra 200 Single Pedal

## STAGE MASTER HARDWARE KIT



### SM4S

- HS40SN Stage Master Snare Stand
- HC42SN Stage Master Straight Cymbal Stand
- HC43BSN Stage Master Boom Cymbal Stand
- HH45SN Stage Master Hi-hat Stand

## THE CLASSIC STAND HARDWARE KIT



### HC4FB

- HS50S Snare Stand
- HC52F Straight Cymbal Stands (x2)
- HH55F Hi-Hat Stand
- SBH01 Hardware Bag

## STANDARD BOOM STAND 2PCS PACK



### HC03BW2

- HC03BW Boom Cymbal Stands (x2)

# POWER TOWER SYSTEM

TAMA's Power Tower System allows you to maintain the same precise set-up time after time. It utilizes 38.1mm stainless round pipes which allow for drums and hardware to be set-up at any angle quickly and easily.

## POWER TOWER SYSTEM BASIC UNIT



### PMD1100M

- 1100mm Curved Pipe x 1pc
- 850mm Straight Pipe w/19.1mm diameter Joint x 2pc
- 40mm x 20mm x 450mm Square Pipe x 2pc
- Leg Joint Bracket x 2pc
- Rubber Foot x 4pc
- Cross Joint Bracket (J30TS) x 2pc
- Multi Holder (J34T) x 2pc
- Memory Lock (A13S) x 4pc

## POWER TOWER SYSTEM ADDITIONAL UNIT



### PMD1100A

- 1100mm Curved Pipe x 1pc
- 850mm Straight Pipe w/19.1mm diameter Joint x 1pc
- 40mm x 20mm x 450mm Square Pipe x 1pc
- Leg Joint Bracket x 1pc
- Rubber Foot x 2pc
- Cross Joint Bracket (J30TS) x 2pc
- Multi Holder (J34T) x 1pc
- Memory Lock (A13S) x 3pc

## POWER TOWER SYSTEM ADDITIONAL UNIT



### PMD900A

- 900mm Curved Pipe x 1pc
- 850mm Straight Pipe w/19.1mm diameter Joint x 1pc
- 40mm x 20mm x 450mm Square Pipe x 1pc
- Leg Joint Bracket x 1pc
- Rubber Foot x 2pc
- Cross Joint Bracket (J30TS) x 2pc
- Multi Holder (J34T) x 1pc
- Memory Lock (A13S) x 3pc

## CROSS JOINT BRACKET



### J30TS

90 degree perpendicular pipe clamp that allows horizontal and vertical pipes to be set at an equal height.

## MULTI HOLDER



### J34T

Rack mount for L-rods, tom or cymbal holders. Fits pipes from 10.5mm to 28.6mm in diameter.

## MEMORY LOCK



### A13S

Memory clamp designed specifically for the Power Tower System.

## SINGLE TOM HOLDER



### MTH900BS

A single tom holder with 25.4mm diameter base tube.

# CLAMPS AND ATTACHMENTS

Back in the 1970's TAMA's original introduction of the multi-clamp was a real revolution in the complex instrument we know as the drum kit. Today, multi-clamps are standard equipment in drums of all brands.

## UNIVERSAL CLAMP



### MC66

One side can hold pipes with diameters from 15.9mm to 28.6mm, while the other side is a ratchet holder that can hold a rod from 9mm to 12mm in diameter at various angles. An excellent clamp for adding an array of new set-up possibilities.

## UNIVERSAL CLAMP

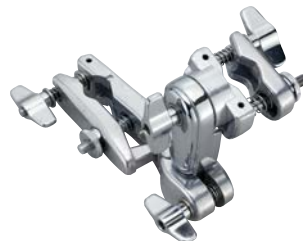

### MC67

The heavier duty version of the MC66. One side holds pipes with diameters from 15.9mm to 28.6mm, while the other side is a ratchet holder that can hold a 12mm to 25.4 mm diameter rod or pipe at various angles.

## UNIVERSAL CLAMP



### MC56

This clamp can be attached to an existing stand pipe that is 15.9mm to 28.9mm in diameter. By attaching a L-Rod or cymbal boom arm that is 9mm to 12mm in diameter, you can easily add a cowbell, woodblock, or cymbal to your drum kit.

## MULTI-CLAMP



### MC61

A basic clamp for connecting stands with pipes from 15.9mm to 28.6mm in diameter with any attachment having a 19.1mm diameter pipe.

## MULTI-CLAMP



### MC62

A double multi-clamp for connecting two pipes from 15.9mm to 28.6mm in diameter. Both sides feature the FastClamp Easy Set-Up System.

## COMPACT CLAMP



### MC5

A clamp for connecting parts with diameters of between 9mm to 12mm together. By combining a boom arm (MCB30EN, MCB45EN) and an L-rod (LLT, LCB, LCYE), this clamp can be used to attach a variety of parts onto a simple boom arm.

## COMPACT CLAMP



### MC7

Same function as the MC5, but with even greater flexibility. The ratchet holder section can hold any diameter tube from 12mm to 25.4mm.

## HOOP GRIP



### MC8

The Hoop Grip is a simple tool that allows you to add cymbals or other accessories to your drum kit to expand your setup and customize your sound.

-available on Steel Hoops and Die-Cast Hoops.  
\*NOT available on Wood Hoops.

## HOOP GRIP FOR BASS DRUM



### MC9

NEW

TAMA's MC9 Hoop Grip for bass drum is a simple clamp. However, when combined with an L-Rod or Z-Rod, you can set splash cymbal or various percussion items on the bass drum. It has a rubber hoop protector preventing scratches and keeping it securely in place. The dual position rod holder allows for mounting on either the right or left side of the clamp. Rod mount attachments are not included.

## Z-ROD FOR COWBELL



### ZCB

Z-rod for mounting cowbell or other percussion instruments and accessories (9mm diameter)

## Z-ROD FOR SPLASH CYMBAL -LONG



### ZCYEL

Z-rod for mounting lightweight cymbals (10.5mm diameter)

Details:  
- Quick-set cymbal mate

## Z-ROD FOR SPLASH CYMBAL -SHORT



### ZCYE

Z-rod for mounting lightweight cymbals (10.5mm diameter)

Details:  
- Quick-set cymbal mate

## ACCESSORY MOUNT ARM



### HCA20

Accessory mount arm for mounting cymbals or accessories for snare drum effects (10.5mm diameter base section)

## HOOP GRIP & ACCESSORY MOUNT ARM



### MC8HCA20

Hoop Grip (MC8) & Accessory Mount Arm (HCA20) bundle package

## HOOP GRIP & Z-ROD FOR COWBELL



### MC8ZCB

Hoop Grip (MC8) & Z-Rod for Cowbell (ZCB) bundle package

## HOOP GRIP & Z-ROD FOR SPLASH CYMBAL -SHORT



### MC8ZCYE

Hoop Grip (MC8) & Z-Rod for Splash Cymbal (ZCYE) bundle package

## HOOP GRIP & Z-ROD FOR SPLASH CYMBAL -LONG



### MC8ZCYEL

Hoop Grip (MC8) & Long Z-Rod for Splash Cymbal (ZCYEL) bundle package

## CLOSED HI-HAT ATTACHMENT



### MXA43

This closed hi-hat attachment utilizes a specially designed screw clutch, allowing for quick, easy, and precise adjustments. The space between the hi-hat cymbals can be adjusted by rotating the screw clutch clockwise or counterclockwise.



## CLOSED HI-HAT ATTACHMENT



### MXA53

Simply designed closed hi-hat attachment that allows for two different settings by turning a lever. Attachable to stands from 15.9mm to 28.6mm in diameter. Great for double bass or double pedal players.

## CLOSED HI-HAT ATTACHMENT



### MXA73N

The tension adjustment knob makes it possible to finely adjust the degree of opening of the hi-hat cymbals. In addition, the angle of the bottom cymbal is also adjustable.

- Quick-set hi-hat clutch
- Quick-set tilter

## L-ROD FOR TOM TOM



### LLT

L-rod for mounting toms (10.5mm diameter).

## L-ROD FOR COWBELL



### LCB

L-rod for mounting different hand percussion instruments and accessories. The 9mm diameter rod fits most popular percussion instruments designed for attachment to a 3/8" rod.

## L-ROD FOR CYMBAL



### LCYE

L-rod for mounting lightweight cymbals.

- Details:
- Quick-set cymbal mate

## L-ROD FOR HI-HAT CYMBAL



### LHH

L-Rod for Hi-hat cymbals.

- Details:
- Screw-Type Hi-hat clutch

## HAT STACK



### CSH5

- Easily attach a small cymbal to hi-hat rod measuring up to 7mm in diameter
- Compact size and lightweight for easy transport and storage - 25mm (1") diameter x 40mm (1.5") height
- Ability to adjust cymbal sustain

## CYMBAL STACKER



### CSA15

The CSA15 is a straight-forward cymbal stacker useful for adding small cymbals to your setup using the M8 threaded cymbal rod.

## CYMBAL STACKER



### CSA25

The CSA25 allows positioning of a small cymbal on the M8 threaded cymbal rod, as well as independent angle adjustment.

## RATCHET ARM



### MTA30

The MTA30 ratchet arm features a 19.1mm pipe.

- Details:
- 300mm (11 3/4") length

## RATCHET ARM



### MTA45

The MTA45 ratchet arm features a 19.1mm pipe.

Details:  
- 450mm (17 3/4") length

## BOOM ARM



### MCB30EN

MCB30EN can be used in combination with a ratchet arm or the MC66 universal clamp is available.

Details:  
- 300mm (11 3/4") length  
- Quick-set tilter  
- Quick-set cymbal mate

## BOOM ARM



### MCB45EN

MCB45EN can be used in combination with a ratchet arm or the MC66 universal clamp is available.

Details:  
- 450mm (17 3/4") length  
- Quick-set tilter  
- Quick-set cymbal mate

## CYMBAL HOLDER



### CACLJ

Bass Drum Mounted Cymbal Holder features telescoping arm & fine gear tilter, which allow you to adjust the angle and height of the cymbal as you like in smaller spaces.

## CYMBAL HOLDER



### CA30EN

Details:  
- 300mm (11 3/4") length  
- Quick-set tilter  
- Quick-set cymbal mate

## CYMBAL HOLDER



### CA45EN

Details:  
- 450mm (17 3/4") length  
- Quick-set tilter  
- Quick-set cymbal mate

## CYMBAL ATTACHMENT



### CCA30

The assortment of boom cymbal holder and MC61 multi-clamp. By connecting to stands from 15.9mm to 28.6mm in diameter, you can add any cymbal easily.

## CYMBAL ATTACHMENT



### MCA53

The MCA53 is a simplified attachment based on the functionality of the MCA63EN. Add cymbals by securing this attachment to stands from 15.9mm to 28.6mm in diameter.

## CYMBAL ATTACHMENT



### MCA63EN

Combines the MC66 universal clamp and the MCB30EN boom arm. Works perfectly for adding cymbals and accessories to stands with pipes from 15.9mm to 28.6mm in diameter.

Details:  
- Quick-set tilter  
- Quick-set cymbal mate

## CYMBAL ATTACHMENT



### CYA5E

Combines the MC5 compact clamp with the LCYE L-rod for mounting one cymbal to one boom arm. Can be clamped to rods from 9mm to 12mm in diameter or to the L-rod of a tom holder.

Details: Quick-set cymbal mate

## TOM ATTACHMENT



### MC69

Clamping this attachment on a 15.9mm to 28.6mm diameter pipe allows for direct set-up of toms. Even with a compact construction, the inclusion of the Omni-ball feature at the angle adjustment point lets you adjust toms to any angle.

## TOM ADAPTER



### MTH900AS

This adapter allows you to add single toms to stands using the flexibility and speed of TAMA's Omni-Ball/L-rod combination.

## COWBELL ATTACHMENT



### CBA5

Compact attachment for mounting hand percussion such as cowbells or tambourines. Combines the MCS compact clamp and the LCB L-rod to provide set-up flexibility. The 3/8" L-rod fits most popular percussion instruments and accessories.

## COWBELL ATTACHMENT



### CBA56

Combines the universal clamp with the LCB L-rod to mount most popular percussion instruments and accessories. Can be attached to pipes ranging from 15.9 mm to 28.6 mm in diameter.

## COWBELL ATTACHMENT



### CBH20

This simple attachment allows cowbells to be mounted on the bass drum. The length and angle of the L-rod can be easily changed for optimum positioning.

## COWBELL ATTACHMENT



### CBH50

The position and angle of the cowbell are adjustable to your preference. The bass drum clamp is now equipped with rubber hoop protectors in order to prevent the hoop from becoming damaged.

## HI-HAT ATTACHMENT



### MHA623

Connects the hi-hat to the hoop of a double bass drum so the hi-hat legs can be closed. An improved design featuring the Para-Clamp mechanism from the Iron Cobra pedal makes attachment even easier and more secure.

## HI-HAT ATTACHMENT



### MHA823

This hi-hat attachment allows for better positioning of a hi-hat stand while using a double bass drum set-up. By connecting the MHA823 to the bass drum hoop, the hi-hat stand can be held upright without opening the hi-hat stand's legs. By utilizing TAMA Omni-Ball system, the clamp is now infinitely adjustable to any angle and enables even greater set-up flexibility. As well, rubber cushions are equipped to protect bass drum hoop from becoming damaged. The clamp is attachable to any hi-hat stand with a pipe diameter of 15.9 - 28.6mm by using the FastClamp Easy Set-Up System.

# MICROPHONE STANDS

Just as many years ago, TAMA single-handedly altered the essence of the modern drum set through its re-invention of drum hardware—TAMA now turns that same degree of engineering dedication to yet another unevolved category of music gear: the microphone stand.

## IRON WORKS STUDIO TELESCOPING BOOM STAND



### MS756BK

- Vice-Grip Boom Tilter
- Iron-Core Legs with Vibration-Isolating Rubber Feet
- Iron-Core Telescoping Boom Arm
- Silent T-Handle
- Detachable Boom Arm
- Height : 975-1650mm (38 3/8"-64 15/16")
- Boom arm : 505-850mm (19 7/8"-33 7/16")
- Weight : 5.4kg (11.9lbs)
- Black Finish

## IRON WORKS STUDIO ROUND BASE TELESCOPING BOOM STAND



### MS756RBK

- Vice-Grip Boom Tilter
- Heavy Round Cast Base
- Iron-Core Telescoping Boom Arm
- Silent T-Handle
- Detachable Boom Arm
- Height : 990mm – 1700mm (39" – 66 13/16")
- Boom arm : 505mm – 850mm (19 7/8" – 33 7/16")
- Weight : 8.2kg (18.1lbs)
- Black Finish

## IRON WORKS STUDIO LOW PROFILE TELESCOPING BOOM STAND



### MS756LBK

- Vice-Grip Boom Tilter
- Iron-Core Legs with Vibration-Isolating Rubber Feet
- Iron-Core Telescoping Boom Arm
- Silent T-Handle
- Detachable Boom Arm
- Height : 440mm - 605mm (17 5/16"– 23 13/16")
- Boom arm : 505mm – 850mm (19 7/8"– 33 7/16")
- Weight : 4.7kg (10.4lbs)
- Black Finish

## IRON WORKS STUDIO ROUND BASE EXTRA LOW PROFILE TELESCOPING BOOM STAND



### MS756RELBK

- Vice-Grip Boom Tilter
- Iron-Core Telescoping Boom Arm
- Silent T-Handle
- Detachable Boom Arm
- Heavy Round Cast Base
- Height : 280mm (11 1/32")
- Boom arm : 505mm – 850mm (19 7/8"– 33 7/16")
- Weight : 7.7kg (17.0lbs)
- Black Finish

## IRON WORKS STUDIO TRIPOD CAST BASE STRAIGHT STAND



### MS750TBK

- Die-cast Locking Thumb Nut
- Sure-Cast Adjustment Collar
- Latch-Lok Sleeve Insert
- Smaller footprint, solid-cast tripod shaped base
- Height : 945mm – 1685mm (37 3/16"– 66 5/16")
- Weight : 3.8kg (8.4lbs)
- Black Finish

## IRON WORKS TOUR BOOM STAND



### MS455BK

- Cast Grip Boom Tilter
- Die-Cast Locking Thumb Nut
- Sure-Cast Adjustment Collar
- Detachable Boom Arm
- Height : 985mm – 1660mm (38 3/4"– 65 3/8")
- Boom arm : 845mm (33 1/4")
- Weight : 3.5kg (7.8lbs)
- Black Finish

## IRON WORKS TOUR TELESCOPING BOOM STAND



### MS456BK

- Cast Grip Boom Tilter
- Die-Cast Locking Thumb Nut
- Sure-Cast Adjustment Collar
- Iron-Core Telescoping Boom Arm
- Detachable Boom Arm
- Height : 985mm – 1660mm (38 3/4"– 65 3/8")
- Boom arm : 845mm (33 1/4")
- Weight : 3.9kg (8.6lbs)
- Black Finish

## IRON WORKS TOUR LOW PROFILE TELESCOPING BOOM STAND



### MS456LBK

- Cast Grip Boom Tilter
- Die-Cast Locking Thumb Nut
- Sure-Cast Adjustment Collar
- Iron-Core Telescoping Boom Arm
- Detachable Boom Arm
- Height : 440mm – 605mm (17 5/16"– 23 13/16")
- Boom arm : 505mm – 845mm (19 7/8"– 33 1/4")
- Weight : 3.1kg (6.9lbs)
- Black Fin



## IRON WORKS TOUR ROUND BASE TELESCOPING BOOM STAND



### MS456RBK

- Cast Grip Boom Tilter
- Die-Cast Locking Thumb Nut
- Sure-Cast Adjustment Collar
- Iron-Core Telescoping Boom Arm
- Heavier Round Cast Base

Height : 1000mm – 1705mm (39 1/4" – 67 1/8")  
 Boom arm : 505mm – 845mm (19 7/8" – 33 1/4")  
 Weight : 7.1kg (15.7lbs)  
 Black Finish

## IRON WORKS TOUR ROUND BASE LOW PROFILE TELESCOPING BOOM STAND



### MS456RLBK

- Cast Grip Boom Tilter
- Die-cast Locking Thumb Nut
- Sure-Cast Adjustment Collar
- Iron-Core Telescoping Boom Arm
- Cast round base with T-bolt pipe fixing devise

Height : 935mm – 1680mm (36 13/16" – 66 1/8")  
 Boom arm : 505mm – 845mm (19 7/8" – 33 1/4")  
 Weight : 3.9kg (8.6lbs)  
 Black Finish

## IRON WORKS TOUR STRAIGHT STAND



### MS450BK

- Die-cast Locking Thumb Nut
- Sure-Cast Adjustment Collar
- Latch-Lok Sleeve Insert

Height : 910mm – 1580mm (35 13/16" – 62 3/16")  
 Weight : 2.3kg (5.1lbs)  
 Black Finish

## IRON WORKS TOUR ROUND BASE STRAIGHT STAND



### MS450DBK

- Die-cast Locking Thumb Nut
- Sure-Cast Adjustment Collar
- Latch-Lok Sleeve Insert
- Cast round base with T-bolt pipe fixing devise

Height : 935mm – 1680mm (36 13/16" – 66 1/8")  
 Weight : 3.9kg (8.6lbs)  
 Black Finish

## IRON WORKS TOUR TABLE TOP STAND



### MS50BK

- Lighter smaller zinc die-cast round base
- 2 stage aluminum pipe construction

Height : 220mm – 370mm (8 5/8" – 14 9/16")  
 Weight : 1.1kg (2.5lbs)  
 Black Finish

## BOOM STAND



### MS205

- Cast Grip Boom Tilter

Height : 960mm – 1600mm (37 13/16" – 63")  
 Boom arm : 830mm (32 11/16")  
 Weight : 3.2kg (7.1 lbs)  
 Chrome Finish

## BOOM STAND



### MS205BK

- Cast Grip Boom Tilter

Height : 960mm – 1600mm (37 13/16" – 63")  
 Boom arm : 830mm (32 11/16")  
 Weight : 3.2kg (7.1 lbs)  
 Black Finish

## LOW PROFILE BOOM STAND



### MS205ST

- Cast Grip Boom Tilter

Height : 430mm – 560mm (17 1/8" – 22 1/16")  
 Boom arm : 510mm (20 1/16")  
 Weight : 2.3kg (5.1 lbs)  
 Chrome Finish

## LOW PROFILE BOOM STAND



### MS205STBK

- Cast Grip Boom Tilter

Height : 430mm – 560mm (17 1/8" – 22 1/16")  
 Boom arm : 510mm (20 1/16")  
 Weight : 2.3kg (5.1 lbs)  
 Black Finish

## BOOM ARM



### MS756BB

Vice-Grip Boom Tilter with Iron-Core Telescoping Boom Arm

## BOOM ARM

### MS456BB

Cast-Grip Boom Tilter with Iron-Core Telescoping Boom Arm



## BOOM ARM

### MS455BB

Cast-Grip Boom Tilter with Standard Boom Arm



## CORD CLIP

### CC5

For 15.9 mm (5/8") diameter tube.



## CORD CLIP

### CC7

For 22.2 mm (7/8") diameter tube.



## DIE-CAST LOCKING THUMB NUT

### DTLN5

For 5/8" connector  
Not only does the thumb nut's larger, sure-grip design allow greater leverage for faster, easier set-up and breakdown, its high quality zinc threads and walls are built to handle pressure for years to come.



## RUBBER FOOT

### 756RF

TAMA's extra thick rubber foot covers "float" the stand, isolating the microphone from floor vibrations. (for 19.1mm diameter leg)



# TAMA PERCUSSION

For more than 40 years, TAMA has been inspiring drummers around the world with its unique range of original percussion instruments. Combining the influences of global musical cultures with modern technology, TAMA has given drummers and percussionists of every genre a new lease on creativity with the unique voices these instruments provide.

## GONG BASS DRUM



### MG20R

MADE IN JAPAN NEW

20"x14" Starclassic Maple Gong Bass Drum

An early TAMA original, the Gong Bass Drum uses a 22" head mounted Tympani style on a 20" shell with no bottom head.

\*Gong Bass Drums is available in Piano Black (PBK) finish only.

## METALWORKS "EFFECT" STEEL MINI-TYMPMS



### MT68STBK

6"x4" + 8"x4"

Steel Mini-Tympms come with an L-rod (LLT) and multi-clamp (MC66).

## METALWORKS "EFFECT" STEEL MINI-TYMPMS



### MT810STBK

8"x4" + 10"x4"

Steel Mini-Tympms come with an L-rod (LLT) and multi-clamp (MC66).

## METALWORKS "EFFECT" STEEL MINI-TYMPMS



### MT1012STBK

10"x4" + 12"x4"

Steel Mini-Tympms come with an L-rod (LLT) and multi-clamp (MC66).

## JINGLE RING



### TJR7

The Jingle Ring is a slim tambourine that can be mounted on a hi-hat stand or as a separate item. It features 9 pairs of nickel "jingles" that produce a bright, clear, tambourine sound.

## OCTOBAN SET



### 7850N2H

2pc High-pitch set w/HOW29WN stand

## OCTOBAN SET



### 7850N2L

2pc Low-pitch set w/HOW29WN stand

## OCTOBAN SET



### 7850N4H

4pc High-pitch set w/HOW49WN stand

## OCTOBAN SET



### 7850N4L

4pc Low-pitch set w/HOW49WN stand

## OCTOBAN



### OCT280N

280mm (11") depth

## OCTOBAN



### OCT301N

301mm (11 3/4") depth

## OCTOBAN



### OCT343N

343mm (13 1/2") depth

## OCTOBAN



### OCT390N

390mm (15 1/2") depth

## OCTOBAN



### OCT443N

443mm (17 1/2") depth

## OCTOBAN



### OCT472N

472mm (18 1/2") depth

## OCTOBAN



### OCT536N

536mm (21") depth

## OCTOBAN



### OCT600N

600mm (23 1/2") depth

## OCTOBAN STAND



### HOW29WN

for 2pcs octobans



## OCTOBAN STAND



### HOW49WN

for 4pcs octobans

## OCTOBAN HOLDER FOR DRUM RACK



### OA29

for 2pcs octobans

## OCTOBAN HOLDER FOR DRUM RACK



### OA49

for 4pcs octobans

# PRACTICE TOOLS

Our unique practice tools make your percussive education more enjoyable and productive.

## PRACTICE PAD



### TSP9

NEW

TAMA's TSP9 Practice Pad accurately imitates the natural feel & rebound of an acoustic snare drum. The wooden base and 6mm thick rubber playing surface offer excellent durability. This combination provides easy control and is ideal for hours long practice sessions. The non-slip base allows the practice pad to rest on a tabletop or snare drum without damaging the surface beneath.

- Unique Playing Surface
- A Natural Feel with the Perfect Bounce
- Portable Compact Size - 9"
- Non-Skid Soft Foam Base

## PRACTICE PAD STAND



### HS40TPN

The HS40TPN practice pad stand can hold pads between 6 and 10 inches in diameter. The EP222 Extension Pipe sold separately.

- Single Braced Legs
- Height Adjustment Range  
w/o extension pipe: 580mm - 710mm (22 13/16" - 27 15/16")  
w/ extension pipe (EP222): 790mm - 1,065mm (31 1/8" - 41 15/16")

## EXTENSION PIPE FOR PRACTICE PAD STAND



### EP222

The height of the HS40TPN can be easily extended by attaching the EP222 extension pipe between the upper and lower section of unit. No tools are required to install this product.

## MESH HEAD



### MH8T

- MH8T (8")
- MH10T (10")
- MH12T (12")
- MH13T (13")
- MH14T (14")
- MH16T (16")
- MH18B (18")
- MH22B (22")

## SOFT SOUND BEATER



### BSQ10S

Soft Sound Beater provides a significant decrease in volume, but allows you to use your regular bass drum pedal and bass drum head with a natural and accurate feel.

## SOFT SOUND BEATER



### BSQ5S

Soft Sound Beater provides a significant decrease in volume, but allows you to use your regular bass drum pedal and bass drum head with a natural and accurate feel.

- Half size version for twin pedal users

## SOFT SOUND RING



### SSR8

The TAMA Soft Sound Ring is made of 6mm thick foam rubber. This drum accessory reduces the volume of an acoustic drum kit while retaining the natural tone of the shell.

SSR8 (8")  
SSR10 (10")  
SSR12 (12")  
SSR13 (13")  
SSR14 (14")  
SSR16 (16")

## SOFT SOUND PACKAGE



### SSRP52K

22" BD 5pc kit configuration

The Soft Sound package reduces the volume of an acoustic drum kit while retaining the natural tone of the shell. It is designed to maintain the feel of playing an acoustic drum kit; a very important feature when playing in low volume situations.

-10", 12", 14v, and 16" Soft Sound Ring  
-Half Soft Sound Beater (BSQ5S)

## SOFT SOUND PACKAGE

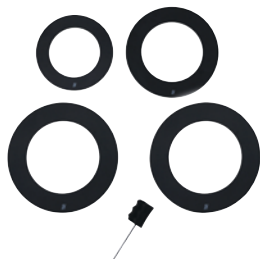

### SSRP50

20" BD 5pc kit configuration

The Soft Sound package reduces the volume of an acoustic drum kit while retaining the natural tone of the shell. It is designed to maintain the feel of playing an acoustic drum kit; a very important feature when playing in low volume situations.

-10", 12", and 2pcs of 14" Soft Sound Ring  
-Half Soft Sound Beater (BSQ5S)

## SOFT SOUND PACKAGE

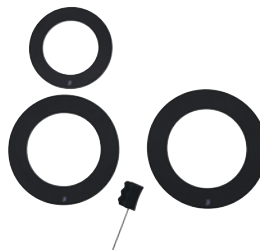

### SSRP48

18" BD 4pc kit configuration

The Soft Sound package reduces the volume of an acoustic drum kit while retaining the natural tone of the shell. It is designed to maintain the feel of playing an acoustic drum kit; a very important feature when playing in low volume situations.

-10", 13", and 14" Soft Sound Ring  
-Half Soft Sound Beater (BSQ5S)

## SILENT TIPS



### TCP20

TAMA TCP20 is a pair of silicone rubber tips that fit over most drum stick models. These tips make it easy and convenient to practice silently, anytime, anywhere.

# BAGS

TAMA's heavy duty bags protect your drums from damage during transportation.

## POWERPAD BAG -Tom Tom-



### PBT8

PBT8 (8"x7" Tom Tom)  
 PBT10 (10"x8" Tom Tom)  
 PBT12 (12"x9" Tom Tom)  
 PBT13 (13"x10" Tom Tom)  
 PBT14 (14"x11" Tom Tom)

## POWERPAD BAG -Floor Tom-



### PBF14

PBF14 (14"x14" Floor Tom)  
 PBF16 (16"x16" Floor Tom)

## POWERPAD BAG -Bass Drum-



### PBB18

PBB18 (18"x16" Bass Drum or Floor Tom)  
 PBB20 (20"x18" Bass Drum)  
 PBB22 (22"x18" Bass Drum)  
 PBB22X (22"x20" Bass Drum)  
 PBB24 (24"x18" Bass Drum)

## POWERPAD BAG -Snare Drum-



### PBS1455

PBS1455 (14"x5.5" Snare Drum)  
 PBS1465 (14"x6.5" Snare Drum)  
 PBS1480 (14"x8" Snare Drum)

## POWERPAD BAG -Hardware-



### PBH02L

880 (L) x 150 (W) x 200 (H) mm  
 (34 5/8" x 5 7/8" x 7 7/8")

-Suitable size for storing about 5 stand

## POWERPAD BAG -Hardware-



### PBH05

850 (L) x 320 (W) x 220 (H) mm  
 (33 1/2" x 12 5/8" x 8 5/8")

-Suitable size for storing about 10 stands  
 -Equipped with durable wheels

## POWERPAD BAG -Cymbal-



### PBC22

The POWERPAD® Series Cymbal Bag is a heavy duty bag designed to carry cymbals up to 22" in diameter. The main compartment contains (3) 22" dividers and the front side pocket contains (3) 15" dividers.

## POWERPAD BAG -Twin Pedal-



### PBP200

The PBP200 can accommodate both single and double pedals.

450 (L) x 300 (W) x 200 (H) mm

## POWERPAD BAG -Single Pedal-



### PBP100

The POWERPAD® Series bag for single pedal.

220 (D) x190 (W) x 400 (H) mm

## POWERPAD BAG -Drum Throne-



### PBTH15

- Carries any TAMA drum throne
- Carries 14" snare drum and snare drum stand
- Shoulder strap and handle for easy transportation

## POWERPAD BAG -Stick & Mallet-



### PBS50

Stores about 24 pairs of sticks & mallets

- Large front pocket for sheet music
- Built-in hooks easily attach to floor tom
- Padded Shoulder strap
- Convenient inner pockets
- Height: 500mm
- Open Width: 580mm

## POWERPAD BAG -Stick-



### PBS24

Stores about 12 pairs of sticks & mallets

## POWERPAD DESIGNER BAG -Drum Set-



### TDSS52KBK

NEW

Black  
22"x18" Bass Drum  
10"x8" Tom Tom  
12"x9" Tom Tom  
16"x16" Floor Tom  
14"x6.5" Snare Drum

- 10mm thick inner cushions
- Ergonomic rubber handle
- A comfortable padded shoulder strap (for the snare drum bag)

## POWERPAD DESIGNER BAG -Drum Set-



### TDSS52KBE

NEW

Beige  
22"x18" Bass Drum  
10"x8" Tom Tom  
12"x9" Tom Tom  
16"x16" Floor Tom  
14"x6.5" Snare Drum

- 10mm thick inner cushions
- Ergonomic rubber handle
- A comfortable padded shoulder strap (for the snare drum bag)

## POWERPAD DESIGNER BAG -Drum Set-



### TDSS52KMG

NEW

Moss Green  
22"x18" Bass Drum  
10"x8" Tom Tom  
12"x9" Tom Tom  
16"x16" Floor Tom  
14"x6.5" Snare Drum

- 10mm thick inner cushions
- Ergonomic rubber handle
- A comfortable padded shoulder strap (for the snare drum bag)

## POWERPAD DESIGNER BAG -Drum Set-



### TDSS52KNB

NEW

Navy Blue  
22"x18" Bass Drum  
10"x8" Tom Tom  
12"x9" Tom Tom  
16"x16" Floor Tom  
14"x6.5" Snare Drum

- 10mm thick inner cushions
- Ergonomic rubber handle
- A comfortable padded shoulder strap (for the snare drum bag)

## POWERPAD DESIGNER BAG -Drum Set-



### TDSS52KWR

NEW

Wine Red  
22"x18" Bass Drum  
10"x8" Tom Tom  
12"x9" Tom Tom  
16"x16" Floor Tom  
14"x6.5" Snare Drum

- 10mm thick inner cushions
- Ergonomic rubber handle
- A comfortable padded shoulder strap (for the snare drum bag)

## POWERPAD DESIGNER BAG -8" Tom Tom-



### TSBT8BK

NEW

Black  
8"x7" Tom Tom

- 10mm thick inner cushions
- Ergonomic rubber handle

**POWERPAD DESIGNER BAG -14" Floor Tom-**



**TSBF14BK** NEW  
Black  
14"x14" Tom Tom  
  
-10mm thick inner cushions  
-Ergonomic rubber handle

**POWERPAD DESIGNER BAG -8" Tom Tom-**



**TSBT8BE** NEW  
Beige  
8"x7" Tom Tom  
  
-10mm thick inner cushions  
-Ergonomic rubber handle

**POWERPAD DESIGNER BAG -14" Floor Tom-**



**TSBF14BE** NEW  
Beige  
14"x14" Tom Tom  
  
-10mm thick inner cushions  
-Ergonomic rubber handle

**POWERPAD DESIGNER BAG -8" Tom Tom-**



**TSBT8MG** NEW  
Moss Green  
8"x7" Tom Tom  
  
-10mm thick inner cushions  
-Ergonomic rubber handle

**POWERPAD DESIGNER BAG -14" Floor Tom-**



**TSBF14MG** NEW  
Moss Green  
14"x14" Tom Tom  
  
-10mm thick inner cushions  
-Ergonomic rubber handle

**POWERPAD DESIGNER BAG -8" Tom Tom-**



**TSBT8NB** NEW  
Navy Blue  
8"x7" Tom Tom  
  
-10mm thick inner cushions  
-Ergonomic rubber handle

**POWERPAD DESIGNER BAG -14" Floor Tom-**



**TSBF14NB** NEW  
Navy Blue  
14"x14" Tom Tom  
  
-10mm thick inner cushions  
-Ergonomic rubber handle

**POWERPAD DESIGNER BAG -8" Tom Tom-**



**TSBT8WR** NEW  
Wine Red  
8"x7" Tom Tom  
  
-10mm thick inner cushions  
-Ergonomic rubber handle

**POWERPAD DESIGNER BAG -14" Floor Tom-**



**TSBF14WR** NEW  
Wine Red  
14"x14" Tom Tom  
  
-10mm thick inner cushions  
-Ergonomic rubber handle

**POWERPAD DESIGNER BAG -Snare Drum-**



**TSDB1465BK**  
Black  
14"x6.5" Snare Drum  
  
-Convertible Backpack Straps  
-20mm thick semi-hard cushion  
-Backpack Straps and ergonomic rubber handle



## POWERPAD DESIGNER BAG -Snare Drum-



### TSDB1465BE

Beige  
14"x6.5" Snare Drum

- Convertible Backpack Straps
- 20mm thick semi-hard cushion
- Backpack Straps and ergonomic rubber handle

## POWERPAD DESIGNER BAG -Snare Drum-



### TSDB1465MG

Moss Green  
14"x6.5" Snare Drum

- Convertible Backpack Straps
- 20mm thick semi-hard cushion
- Backpack Straps and ergonomic rubber handle

NEW

## POWERPAD DESIGNER BAG -Snare Drum-



### TSDB1465NB

Navy Blue  
14"x6.5" Snare Drum

- Convertible Backpack Straps
- 20mm thick semi-hard cushion
- Backpack Straps and ergonomic rubber handle

## POWERPAD DESIGNER BAG -Snare Drum-



### TSDB1465WR

Wine Red  
14"x6.5" Snare Drum

- Convertible Backpack Straps
- 20mm thick semi-hard cushion
- Backpack Straps and ergonomic rubber handle

## POWERPAD BAG -Hardware-



### THB02LBK

Black

880 (L) x 150 (W) x 200 (H) mm  
(34 5/8" x 5 7/8" x 7 7/8")

- Suitable size for storing about 4 stands

## POWERPAD BAG -Hardware-



### THB02LBE

Beige

880 (L) x 150 (W) x 200 (H) mm  
(34 5/8" x 5 7/8" x 7 7/8")

- Suitable size for storing about 4 stands

## POWERPAD BAG -Hardware-



### THB02LMG

Moss Green

880 (L) x 150 (W) x 200 (H) mm  
(34 5/8" x 5 7/8" x 7 7/8")

- Suitable size for storing about 4 stands

## POWERPAD BAG -Hardware-



### THB02LNB

Navy Blue

880 (L) x 150 (W) x 200 (H) mm  
(34 5/8" x 5 7/8" x 7 7/8")

- Suitable size for storing about 4 stands

## POWERPAD BAG -Hardware-



### THB02LWR

Wine Red

880 (L) x 150 (W) x 200 (H) mm  
(34 5/8" x 5 7/8" x 7 7/8")

- Suitable size for storing about 4 stands

## POWERPAD DESIGNER BAG -Cymbal-



### TCB22BK

Black  
up to 22" Cymbal + 15" Cymbal (front side pocket)

- 20mm thick semi-hard cushion
- Padded shoulder Straps and handle
- 22" compartment dividers (3pcs) and 15" compartment dividers (3pcs) included

## POWERPAD DESIGNER BAG -Cymbal-



### TCB22BE

Beige  
up to 22" Cymbal + 15" Cymbal (front side pocket)

- 20mm thick semi-hard cushion
- Padded shoulder Straps and handle
- 22" compartment dividers (3pcs) and 15" compartment dividers (3pcs) included

## POWERPAD DESIGNER BAG -Cymbal-



### TCB22MG

Moss Green NEW  
up to 22" Cymbal + 15" Cymbal (front side pocket)

- 20mm thick semi-hard cushion
- Padded shoulder Straps and handle
- 22" compartment dividers (3pcs) and 15" compartment dividers (3pcs) included

## POWERPAD DESIGNER BAG -Cymbal-



### TCB22NB

Navy Blue  
up to 22" Cymbal + 15" Cymbal (front side pocket)

- 20mm thick semi-hard cushion
- Padded shoulder Straps and handle
- 22" compartment dividers (3pcs) and 15" compartment dividers (3pcs) included

## POWERPAD DESIGNER BAG -Cymbal-



### TCB22WR

Wine Red  
up to 22" Cymbal + 15" Cymbal (front side pocket)

- 20mm thick semi-hard cushion
- Padded shoulder Straps and handle
- 22" compartment dividers (3pcs) and 15" compartment dividers (3pcs) included

## POWERPAD DESIGNER BAG -Cajon-



### TCB01BK

Black  
330 (L) x 310 (W) x 520 (H) mm  
(13" x 12 1/4" x 20 1/2")

- Backpack straps

## POWERPAD DESIGNER BAG -Cajon-



### TCB01BE

Beige  
330 (L) x 310 (W) x 520 (H) mm  
(13" x 12 1/4" x 20 1/2")

- Backpack straps

## POWERPAD DESIGNER BAG -Cajon-



### TCB01MG

Moss Green NEW  
330 (L) x 310 (W) x 520 (H) mm  
(13" x 12 1/4" x 20 1/2")

- Backpack straps

## POWERPAD DESIGNER BAG -Cajon-



### TCB01NB

Navy Blue  
330 (L) x 310 (W) x 520 (H) mm  
(13" x 12 1/4" x 20 1/2")

- Backpack straps

## POWERPAD DESIGNER BAG -Cajon-



### TCB01WR

Wine Red  
330 (L) x 310 (W) x 520 (H) mm  
(13" x 12 1/4" x 20 1/2")

- Backpack straps

## POWERPAD DESIGNER BAG -Twin Pedal-



### TPB200BK

Black  
450 (L) x 200 (W) x 300 (H) mm  
(17 3/4" x 7 7/8" x 11 3/4")

- Accommodate both single and double pedals
- Removable storage case for using as single pedal case

## POWERPAD DESIGNER BAG -Twin Pedal-



### TPB200BE

Beige

450 (L) x 200 (W) x 300 (H) mm  
(17 3/4" x 7 7/8" x 11 3/4")

-Accommodate both single and double pedals  
-Removable storage case for using as single pedal case

## POWERPAD DESIGNER BAG -Twin Pedal-



### TPB200MG

NEW

Moss Green

450 (L) x 200 (W) x 300 (H) mm  
(17 3/4" x 7 7/8" x 11 3/4")

-Accommodate both single and double pedals  
-Removable storage case for using as single pedal case

## POWERPAD DESIGNER BAG -Twin Pedal-



### TPB200NB

Navy Blue

450 (L) x 200 (W) x 300 (H) mm  
(17 3/4" x 7 7/8" x 11 3/4")

-Accommodate both single and double pedals  
-Removable storage case for using as single pedal case

## POWERPAD DESIGNER BAG -Twin Pedal-



### TPB200WR

Wine Red

450 (L) x 200 (W) x 300 (H) mm  
(17 3/4" x 7 7/8" x 11 3/4")

-Accommodate both single and double pedals  
-Removable storage case for using as single pedal case

## POWERPAD DESIGNER BAG -Stick-



### TSB24BK

Black

-Main pockets for 12 pairs of sticks, and side pockets for accessories  
-Built-in hooks easily attach to floor tom  
-Shoulder strap for portability  
-Convenient inner pockets  
-Size: 460mm x 180mm  
-Side Pocket: 260mm x 160mm

## POWERPAD DESIGNER BAG -Stick-



### TSB24BE

Beige

-Main pockets for 12 pairs of sticks, and side pockets for accessories  
-Built-in hooks easily attach to floor tom  
-Shoulder strap for portability  
-Convenient inner pockets  
-Size: 460mm x 180mm  
-Side Pocket: 260mm x 160mm

## POWERPAD DESIGNER BAG -Stick-



### TSB24MG

NEW

Moss Green

-Main pockets for 12 pairs of sticks, and side pockets for accessories  
-Built-in hooks easily attach to floor tom  
-Shoulder strap for portability  
-Convenient inner pockets  
-Size: 460mm x 180mm  
-Side Pocket: 260mm x 160mm

## POWERPAD DESIGNER BAG -Stick-



### TSB24NB

Navy Blue

-Main pockets for 12 pairs of sticks, and side pockets for accessories  
-Built-in hooks easily attach to floor tom  
-Shoulder strap for portability  
-Convenient inner pockets  
-Size: 460mm x 180mm  
-Side Pocket: 260mm x 160mm

## POWERPAD DESIGNER BAG -Stick-



### TSB24WR

Wine Red

-Main pockets for 12 pairs of sticks, and side pockets for accessories  
-Built-in hooks easily attach to floor tom  
-Shoulder strap for portability  
-Convenient inner pockets  
-Size: 460mm x 180mm  
-Side Pocket: 260mm x 160mm

## POWERPAD DESIGNER BAG -Stick-



### TSB12BK

Black

Stores about 6 pairs of sticks

-Top of the bag open to take out stick easily  
-Elastic band easily attach to floor tom  
-Convenient inner pockets

## POWERPAD DESIGNER BAG -Stick-



### TSB12BE

Beige  
Stores about 6 pairs of sticks

- Top of the bag open to take out stick easily
- Elastic band easily attach to floor tom
- Convenient inner pockets

## POWERPAD DESIGNER BAG -Stick-



### TSB12MG

Moss Green  
Stores about 6 pairs of sticks

- Top of the bag open to take out stick easily
- Elastic band easily attach to floor tom
- Convenient inner pockets

NEW

## POWERPAD DESIGNER BAG -Stick-



### TSB12NB

Navy Blue  
Stores about 6 pairs of sticks

- Top of the bag open to take out stick easily
- Elastic band easily attach to floor tom
- Convenient inner pockets

## POWERPAD DESIGNER BAG -Stick-



### TSB12WR

Wine Red  
Stores about 6 pairs of sticks

- Top of the bag open to take out stick easily
- Elastic band easily attach to floor tom
- Convenient inner pockets

## POWERPAD DESIGNER BAG -Stick-



### TSB12DBK

Black Denim  
Stores about 6 pairs of sticks

- Top of the bag open to take out stick easily
- Elastic band easily attach to floor tom
- Convenient inner pockets

## POWERPAD DESIGNER BAG -Stick-



### TSB12DBL

Blue Denim  
Stores about 6 pairs of sticks

- Top of the bag open to take out stick easily
- Elastic band easily attach to floor tom
- Convenient inner pockets

## STANDARD SERIES DRUM BAG SET



### DSS52K

22"x18"BD  
10"x8"TT  
12"x9"TT  
16"x16"FT  
14"x6.5"SD

- 600 denier high density water resister surface
- Water resistant nylon with 10mm thick cushion
- Ergonomic rubber handles

## STANDARD SERIES DRUM BAG SET



### DSS50S

20"x18"BD  
10"x8"TT  
12"x9"TT  
14"x14"FT  
14"x6.5"SD

- 600 denier high density water resister surface
- Water resistant nylon with 10mm thick cushion
- Ergonomic rubber handles

## STANDARD SERIES DRUM BAG SET



### DSS62S

22"x18"BD  
10"x8"TT  
12"x9"TT  
14"x14"FT  
16"x16"FT  
14"x6.5"SD

- 600 denier high density water resister surface
- Water resistant nylon with 10mm thick cushion
- Ergonomic rubber handles

## STANDARD SERIES DRUM BAG SET



### DSS48LJ

(for Club-JAM kit)  
18"x12"BD  
10"x8"TT  
14"x7"FT & 13"x5"SD (1bag)

- 600 denier high density water resister surface
- Water resistant nylon with 10mm thick cushion
- Ergonomic rubber handles



## STANDARD SERIES DRUM BAG SET



### DSS28LJ

(for Club-JAM MINI kit)  
18"x12" BD  
12"x5" SD

- 600 denier high density water resister surface
- Water resistant nylon with 10mm thick cushion
- Ergonomic rubber handles

## STANDARD SERIES DRUM BAG SET



### DSS36LJ

(for Club-JAM Suitcase kit)  
16"x15" BD  
10"x7" TT  
12"x6" FT

- 600 denier high density water resister surface
- Water resistant nylon with 10mm thick cushion
- Ergonomic rubber handles

NEW

## STANDARD SERIES DRUM BAG SET



### DSS44LJ

(for Club-JAM Flyer kit)  
14"x10" BD  
10"x9" FT & 8"x6" TT (1bag)  
10"x5" SD bag

- 600 denier high density water resister surface
- Water resistant nylon with 10mm thick cushion
- Ergonomic rubber handles

## STANDARD SERIES DRUM BAG SET



### DSS48S

14"x18" BD  
12"x9" TT  
14"x14" FT  
14"x6.5" SD

- 600 denier high density water resister surface
- Water resistant nylon with 10mm thick cushion
- Ergonomic rubber handles

## STANDARD SERIES DRUM BAG SET



### DSS72S

22"x18" BD  
8"x7" TT  
10"x8" TT  
12"x9" TT  
14"x14" FT  
16"x16" FT  
14"x6.5" SD

- 600 denier high density water resister surface
- Water resistant nylon with 10mm thick cushion
- Ergonomic rubber handles

## STANDARD SERIES CAJON BAG



### SBC01

Size: 520 (L) x 310 (W) x 330 (H) mm  
Side Pocket: 520 (L) x 50 (W) x 330 (H) mm

- Designed for smooth extraction and insertion of Cajon
- 600 denier high density water resister surface
- Water resistant nylon with 10mm thick cushion

## STANDARD SERIES HARDWARE BAG



### SBH01

(for Compact / Lightweight Hardware)  
670 (L) x180 (W) x190 (H) mm

- 600 denier high density water resister surface
- Water resistant nylon with 10mm thick cushion
- Carrying strap with shoulder pads

## STANDARD SERIES MICROPHONE STAND BAG



### SBM01

Stores up to 6 pcs of Microphone Stands or 2pcs of Speaker Stands  
1200 (L) x 220 (W) x 200 (H) mm

- 600 denier high density water resister surface
- Water resistant nylon with 10mm thick cushion
- Carrying strap with shoulder pad



# ACCESSORIES

We offer many unique accessories to enhance your playing, set up, and tone of the drums.

## RHYTHM WATCH



### RW200

Tempo Range: 30-250 BPM  
 Tempo, Beat & Sound Memory: 30 Songs  
 Beats: 0-9  
 Display: LCD with BACK LIGHT  
 Size: 127 x 35 x 150mm (5" x 1.4" x 6")  
 Weight: 285g including battery  
 Power Supply: 9V Battery (S-006P) or DC9V 200mA adapter

## RHYTHM WATCH MINI



### RW30

Tempo Range: 30-250 BPM  
 Beats: 0-9  
 Display: LCD display with BACK LIGHT  
 Size: 61 x 25 x 118mm (2 1/2" x 1" x 4 5/8")  
 Weight: 90g including battery  
 Power Supply: 2 x AAA Batteries (3V)

## RHYTHM WATCH HOLDER



### RWH10

for RW200

## TENSION WATCH



### TW200

The TW200 TAMA Tension Watch is very compact and is equipped with an easy to read dial. It comes with a detachable nylon bumper to ensure consistent measuring distance from the hoop, resulting in an evenly tensioned drum for the best sound.

## TENSION WATCH



### TW100

The TW100 measures actual head tension and features an easy-to-read meter, so you can record the numbers and duplicate your best tuning time after time. You can also use the sample tunings suggested in the directions.

## DRUMMER'S GLOVE



### TDG10BKL

Drummer's Glove with featuring extra soft and durable synthetic leather which prevents any slipping while playing even with wet condition caused by sweating.

Black  
 TDG10BKM (Medium)  
 TDG10BKL (Large)  
 TDG10BKXL (Extra Large)

## DRUMMER'S GLOVE



### TDG10WHL

Drummer's Glove with featuring extra soft and durable synthetic leather which prevents any slipping while playing even with wet condition caused by sweating.

White  
 TDG10WHM (Medium)  
 TDG10WHL (Large)

## GRIP WRAP

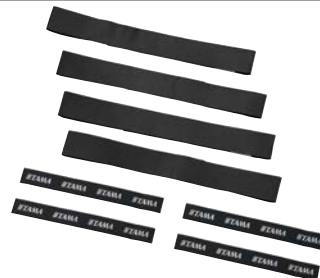

### TWG10BK

MADE IN JAPAN NEW

(2prs / set)  
 TAMA's Grip Wrap is designed to provide the player with a comfortable, non-slip surface for their drumsticks.

-Non-Slip Surface  
 -Soft and Comfortable Feel  
 -Highly Durable Material Made in Japan

## WOOD HOOP PROTECTOR



### WHP2

(2pcs / set)  
Special adhesive pieces protect your wood hoop from being scratched by preventing the bass drum pedal from twisting or slipping.

## MULTI TOOL



### TMT9

Quick access multi tool for drums  
-Hex Wrench 5.0mm/4.0mm/3.0mm/2.5mm/  
2.0mm, Keychain Link, Hex Nut Driver, Phillips  
Screwdriver, Drum Keys (x2)

## STAND WEIGHT



### TSW10

TAMA Stand Weight enables you to stabilize your stand firmly on any surface simply by looping the weight around the tripod base.  
Weight: 3kg (6.6lb)

## DRUM RUG -TAMA Logo Pattern-



### TDRTL

1,800mm x 2,000mm  
(70 7/8" x 78 3/4")

- Non-slip design helps keep drums & hardware in place
- Extra-large size accommodates most drum setups
- Hook and loop fasteners for easy transport

## DRUM RUG -TAMA Logo Pattern / Small-



### TDRSTL

1,330mm x 1,680mm  
(52 3/8" x 66 1/8")

NEW

- Non-slip design helps keep drums & hardware in place
- Fits to accommodate compact drum set
- Hook and loop fasteners for easy transport

## DRUM RUG -Oriental Pattern-

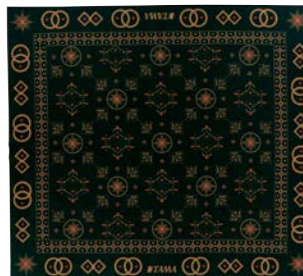

### TDROR

1,800mm x 2,000mm  
(70 7/8" x 78 3/4")

- Non-slip design helps keep drums & hardware in place
- Extra-large size accommodates most drum setups
- Hook and loop fasteners for easy transport

## DRUM RUG -Southwestern Pattern-



### TDRSW

1,800mm x 2,000mm  
(70 7/8" x 78 3/4")

- Non-slip design helps keep drums & hardware in place
- Extra-large size accommodates most drum setups
- Hook and loop fasteners for easy transport

## DRUM RUG -Paisley Pattern-



### TDRPA

1,800mm x 2,000mm  
(70 7/8" x 78 3/4")

- Non-slip design helps keep drums & hardware in place
- Extra-large size accommodates most drum setups
- Hook and loop fasteners for easy transport

## REMO FIBERSKYN POWERSTROKE 3 DIPLOMAT



### RF22BMST

(TAMA Logo)  
RF16BMST (16")  
RF18BMST (18")  
RF20BMST (20")  
RF22BMST (22")  
RF24BMST (24")  
RF26BMST (26")

## WHITE COATED HEADS



### CT22BMOT

(TAMA & Starclassic Logo)  
CT18BMOT (18")  
CT20BMOT (20")  
CT22BMOT (22")  
CT24BMOT (24")  
CT26BMOT (26")

## FIBER LAMINATED HEADS



### FB22BMFS

(TAMA & Starclassic Logo)  
 FB16BMFS (16")  
 FB18BMFS (18")  
 FB20BMFS (20")  
 FB22BMFS (22")  
 FB24BMFS (24")

## BLACK HEADS



### BK22BMTT

(TAMA & Starclassic Logo)  
 BK16BMTT (16")  
 BK18BMTT (18")  
 BK20BMTT (20")  
 BK22BMTT (22")  
 BK24BMTT (24")  
 BK26BMTT (26")

## SMOOTH WHITE HEADS



### SW22BMTT

(TAMA & Starclassic Logo)  
 SW16BMTT (16")  
 SW18BMTT (18")  
 SW20BMTT (20")  
 SW22BMTT (22")  
 SW24BMTT (24")

## FIBER LAMINATED HEADS -BLACK-



### BK22BMFH

(TAMA Logo for Superstar Hyper-Drive)  
 BK20BMFH (20")  
 BK22BMFH (22")  
 BK24BMFH (24")

## WHITE COATED HEADS -TAMA LOGO-



### CT22BMSV

(TAMA Logo)  
 CT18BMSV (18")  
 CT20BMSV (20")  
 CT22BMSV (22")  
 CT24BMSV (24")

## BLACK HEADS -TAMA LOGO-



### BK22BMWS

(TAMA Logo)  
 BK20BMWS (20")  
 BK22BMWS (22")  
 BK24BMWS (24")

## DRUM KEY



### TDK10

Chrome

## DRUM KEY



### TDK10BN

Black Nickel

## DRUM KEY



### 6560

## TENSION LOCK



### TTL10

(10pcs/set)

The Tension Lock prevents tension bolts from loosening while playing by simply set it on the tension bolt head. You can tune the drum without having to detach the Tension Lock, thanks to an elastic O-ring around its hole.

## DIE-CAST HOOPS



### MDH1410

TAMA's die-cast hoops deliver an incredibly sharp, solid rim shot that cannot be found in any other hoop.

MDH148 (14" 8 hole batter side)  
MDH14S8 (14" 8 hole snare side)  
MDH1410 (14" 10 hole batter side)  
MDH14S10 (14" 10 hole snare side)

## 2.3mm BRASS MIGHTY HOOPS



### MFB1410N

Brass Mighty Hoop provides a warm and open sound with mild attack and long sustain.

MFB1410N (14" 10 hole batter side)  
MFB14S10N (14" 10 hole snare side)

## 2.3mm STEEL MIGHTY HOOPS



### MFM1410

Steel Mighty Hoop provides a bright and open sound.

MFM148 (14" 8 hole batter side)  
MFM14S8 (14" 8 hole snare side)  
MFM1410 (14" 10 hole batter side)  
MFM14S10 (14" 10 hole snare side)

## 3.0mm ULTIMATE STEEL MIGHTY HOOPS



### MUS1410

3.0mm thick Ultimate Steel Mighty Hoop provides extra power and volume.

MUS1410 (14" 10 hole batter side)  
MUS14S10 (14" 10 hole snare side)

## 2.3mm SOUND ARC HOOPS



### MSH1410

Steel Sound Arc Hoop enhances the natural tone of the snare drum and offers sensitivity, precise tuning, and control.

MSH1410 (14" 10 hole batter side)  
MSH14S10 (14" 10 hole snare side)

## 2.3mm BRASS SOUND ARC HOOPS



### MSB148D

Brass Sound Arc Hoop provides an open sound with rich harmonic overtones, made of brass with an inward curved shape.

MSB148D (14" 8 hole batter side)  
MSB14S8D (14" 8 hole snare side)

## CUSTOMIZED BRASS MIGHTY HOOPS



### MSP148

Customized Brass Mighty Hoop provides a sharper and brighter attack with rich harmonic overtones, made of brass with a slightly shaved down edge.

MSP148 (14" 8 hole batter side)  
MSP14S8 (14" 8 hole snare side)

## MAPLE WOOD HOOPS



### WMH1410B

Wood Hoop provides a warm, woody sound with soft attack. Can be mounted on a standard 14" snare drum stand.

WMH1408B (14" 8 hole batter side)  
WMH1408S (14" 8 hole snare side)  
WMH1410B (14" 10 hole batter side)  
WMH1410S (14" 10 hole snare side)

## SUPER SENSITIVE HI-CARBON SNARE WIRES



### MS20RL14C

Super Sensitive Hi-Carbon Snare Wire fits more closely to the snare side head, providing greater sensitivity and brighter, crisper sound.

MS20RL13C (13" 20 strands Hi-Carbon Steel)  
MS20RL14C (14" 20 strands Hi-Carbon Steel)

## SUPER SENSITIVE HI-CARBON SNARE WIRE FOR CONCERT



### MS20L14C8

A thin brass plate and softer hi-carbon coils respond to even the softest touch on the edge of the batter head.

MS20L14C8 (14" 20 strands Hi-Carbon Steel)

## STAINLESS STEEL STRAIGHT SNARE WIRE

### MS20M14ST

20 strands steel straight wire for concert. Extra short sustain, dark and crisp.

MS20M14ST (14" 20 strands Steel)



## STARCLASSIC SNARE WIRES -CARBON STEEL-

### MS20SN14S

MS20SN10S (10" 20 strands Carbon Steel)  
MS20SN12S (12" 20 strands Carbon Steel)  
MS20SN13S (13" 20 strands Carbon Steel)  
MS20SN14S (14" 20 strands Carbon Steel)



## STARCLASSIC SNARE WIRES -BELL BRASS-

### MS20SN14B

The MS20SN14B features bell brass strands for greater sensitivity.

MS20SN14B (14" 20 strands Bell Brass)



## STARCLASSIC SNARE WIRES -HI-CARBON STEEL-

### MS20SN14C

MS20SN13C (13" 20 strands Hi-Carbon Steel)  
MS20SN14C (14" 20 strands Hi-Carbon Steel)



## REGULAR SNARE WIRES -CARBON STEEL-

### MS12R14S

(14" 12 strands Carbon Steel)



## REGULAR SNARE WIRES -CARBON STEEL-

### MS20R14S

(14" 20 strands Carbon Steel)



## REGULAR SNARE WIRES -CARBON STEEL-

### MS30R14S

(14" 30 strands Carbon Steel)



## REGULAR SNARE WIRES -CARBON STEEL-

### MS42R14S

(14" 42 strands Carbon Steel)



## REGULAR SNARE WIRES -HI-CARBON STEEL-

### MS42R14C

(14" 42 strands Hi-Carbon Steel)



## HOLD TIGHT™ WASHERS

### SRW620P

(20pcs/set)

The rubber rings inside of the cup-shaped stainless steel washers absorb impact vibrations and keep the hoop and tension bolts in constant contact to prevent from loosening of tension.





## PLASTIC WASHERS



### PW620

(20pcs/set)  
2.5mm thick nylon washers decrease noise and make tuning easier and more stable.

## METAL WASHERS



### MW620

(20pcs/set)  
Standard metal tension bolt washers.

## SNARE WIRE STRAPS



### MST20

(2pcs/set)  
These flexible yet durable 15mm wide nylon snare wire straps are featured on most of TAMA snare drums.

## SNARE WIRE STRINGS



### SPC50P4

(2prs/pack)  
The amazingly durable and flexible snare wire string is made of Dupont Kevlar® cable wrapped in polyester fiber for an even higher tensile strength than steel wire. (Kevlar® is a registered trademark of Dupont® Corporation.)

## DYNA BEATER



### BDY30FB

Featuring black felt and a slightly tapered shape, this traditional style beater provides impact to the bass drum head surface evenly to maximize clear, dynamic articulation.

## POWER-STRIKE COBRA BEATER



### CB900PS

Felt

## ACCU-STRIKE COBRA BEATER



### CB900AS

Rubber

## COBRA BEATER -Felt-



### CB90F

Felt

## COBRA BEATER -Rubber-



### CB90R

Rubber

## COBRA BEATER -Wood-



### CB90W

Wood

**POWER-STRIKE COBRA BEATER HEAD**



**CB900PSH**

Felt

**ACCU-STRIKE COBRA BEATER HEAD**



**CB900ASH**

Rubber

**COBRA BEATER HEAD -Felt-**



**CB90FH**

Felt

**COBRA BEATER HEAD -Rubber-**



**CB90RH**

Rubber

**COBRA BEATER HEAD -Wood-**



**CB90WH**

Wood

**DUAL SIDED BEATER -Felt-**



**DS30**

Felt

**DUAL SIDED BEATER -Felt-**



**DS30G**

Felt

**THE CLASSIC BEATER -Felt-**



**CLB30F**

Felt

**TRADITIONAL BEATER -Felt-**



**TTB30F**

Felt

**TRADITIONAL BEATER -Wood-**



**TTB30W**

Wood

## TOE STOPPER

**HP90081**



## BEATER BALANCER

**BC7**



## TIGHT LOCK

**TLK5**



## SPRING FOR SPEED COBRA

**HP9107S**



## SPRING -Regular-

**HP9007R**



## SPRING -Heavy-

**HP9007H**



## COBRA COIL

**CC900S**

The Cobra Coil is a steel spring which assists in the return of the footboard to its original position. It be adjusted to different positions, forward or backward, on the base plate.



## DRUM HAMMER

**DH7**



## TWIN PEDAL ATTACHMENT

**TPA90**

Specially designed attachment to connect Speed Cobra and Iron Cobra 900 series pedals with Speed Cobra and Iron Cobra 900 series Hi-hat stands.



## DYNA-SYNC PEDAL CASE -SINGLE-

**PCDS1**

PCDS1 (for Dyna-Sync Single Pedal)



### DYNA-SYNC PEDAL CASE -TWIN-



#### PCDS1TW

PCDS1TW (for Dyna-Sync Twin Pedal)

### IRON COBRA PEDAL CASE -SINGLE-



#### PC900S

PC900S (for Iron Cobra Single Pedal)

### IRON COBRA PEDAL CASE -TWIN-



#### PC900TW

PC900TW (for Iron Cobra Twin Pedal)

### SPEED COBRA PEDAL CASE -SINGLE-



#### PC910S

PC910S (for Speed Cobra Single Pedal)

### SPEED COBRA PEDAL CASE -TWIN-



#### PC910TW

PC910TW (for Speed Cobra Twin Pedal)

### 1ST CHAIR ROUND RIDER XL SEAT -Cloth Top-



#### HTS8BC

You can improve your existing throne with the firm support and comfort of 1st Chair seats (fits pipes from 19.1mm to 25.4mm in diameter).

### 1ST CHAIR ROUND RIDER XL SEAT



#### HTS8B

You can improve your existing throne with the firm support and comfort of 1st Chair seats (fits pipes from 19.1mm to 25.4mm in diameter).

### 1ST CHAIR ROUND RIDER XL SEAT -Red-



#### HTS8R

You can improve your existing throne with the firm support and comfort of 1st Chair seats (fits pipes from 19.1mm to 25.4mm in diameter).

### 1ST CHAIR ERGO-RIDER SEAT -Cloth Top-



#### HTS7BC

You can improve your existing throne with the firm support and comfort of 1st Chair seats (fits pipes from 19.1mm to 25.4mm in diameter).

### 1ST CHAIR ERGO-RIDER SEAT



#### HTS7B

You can improve your existing throne with the firm support and comfort of 1st Chair seats (fits pipes from 19.1mm to 25.4mm in diameter).

## 1ST CHAIR GLIDE RIDER SEAT -Cloth Top-



### HTS5BCN

You can improve your existing throne with the firm support and comfort of 1st Chair seats (fits pipes from 19.1mm to 25.4mm in diameter).

## 1ST CHAIR ROUND RIDER SEAT -Cloth Top-



### HTS4BC

You can improve your existing throne with the firm support and comfort of 1st Chair seats (fits pipes from 19.1mm to 25.4mm in diameter).

## 1ST CHAIR ROUND RIDER SEAT



### HTS4B

You can improve your existing throne with the firm support and comfort of 1st Chair seats (fits pipes from 19.1mm to 25.4mm in diameter).

## 1ST CHAIR THRONE BASE -HYDRAULIX-



### HSB5N

\*Seat holder included.

You can improve your existing throne or seat by changing the legs to one of the 1st Chair individual throne bases. The Hydraulics throne base comes with a seat holder with an adjustment lever.

## 1ST CHAIR THRONE BASE -Quartet-



### HSB4N

You can improve your existing throne or seat by changing the legs to one of the 1st Chair individual throne bases. (diameter of upper rods: 22.2mm).

## 1ST CHAIR THRONE BASE -Trio-



### HSB3N

You can improve your existing throne or seat by changing the legs to one of the 1st Chair individual throne bases. (diameter of upper rods: 22.2mm).

## 1ST CHAIR THRONE BASE -Trio-



### HSB3

for Round Rider Series

You can improve your existing throne or seat by changing the legs to one of the 1st Chair individual throne bases. (diameter of upper rods: 22.2mm).

## 1ST CHAIR BACKREST ATTACHMENT



### HTB5B

for any 1st Chair thrones

Sitting on a throne for a long period of time is tough on your back. The HTB5B can be adjusted up and down AND forward AND it can be detached from the seat when the gig is done. Slick!

## TAMA LOGO STICKER -White-



### TLS100WH

TLS120WH 60mm x 280mm  
TLS100WH 50mm x 230mm  
TLS80WH 40mm x 190mm  
TLS70WH 35mm x 150mm

## TAMA LOGO STICKER -Black-



### TLS100BK

TLS120BK 60mm x 280mm  
TLS100BK 50mm x 230mm  
TLS80BK 40mm x 190mm  
TLS70BK 35mm x 150mm



## SONIC MUTE



### TSM01

(2pcs/set)  
Removable, reusable & reliable mute patch.  
Adjustable for optimum precision and control.  
(Wash lightly to restore adhesion).

## MEMORY LOCK



### ML11

for 10.5mm diameter L-rod

## MEMORY LOCK



### ML12

for 10.5-12mm diameter boom arm

List: \$13.00

## MEMORY LOCK



### ML191C

for 19.1mm diameter pipe

List: \$16.00

## MEMORY LOCK



### ML191N

for 19.1mm diameter pipe

## MEMORY LOCK



### ML222C

for 22.2mm diameter pipe

## MEMORY LOCK



### ML222NT

for 22.2mm diameter pipe

## MEMORY LOCK



### ML254TC

for 25.4mm diameter pipe

## MEMORY LOCK



### ML254C

for 25.4mm diameter pipe

## MEMORY LOCK



### ML28C

for 28.6mm diameter pipe

## QUICK-SET CYMBAL MATE



**QC8**  
(M8)

## QUICK-SET CYMBAL MATE (4pcs/set)



**QC8B4**  
(M8: 4pcs/pack)

## CYMBAL MATE



**CM8P**  
(M8: 2pcs/pack)

## RING-TRUE FELT for STAR Hardware



**RTF35P**  
(2pcs/pack)

## FELT WASHER



**7081P**  
(2pcs/pack)

## REVERSIBLE CYMBAL BOTTOM



**RB8P**  
(M8: 2pcs/pack)

## STAR HARDWARE CYMBAL BOTTOM



**CB8P**  
(M8: 2pcs/pack)

## CYMBAL PROTECTION SLEEVE



**CPS8P**  
(M8: 2pcs/pack)

## HAT STACK



**CSH5**  
- Easily attach a small cymbal to hi-hat rod measuring up to 7mm in diameter  
- Compact size and lightweight for easy transport and storage - 25mm (1") diameter x 40mm (1.5") height  
- Ability to adjust cymbal sustain

## SIZZLE TOUCH DROP CLUTCH



**STDC7**  
TAMA's Sizzle Touch Drop Clutch allows you to adjust the gap between the top and bottom cymbals, allowing for fine adjustments to achieve the desired open sound.

## QUICK-SET HI-HAT CLUTCH



### QHC7

With just one touch, the Quick-Set Clutch can be attached or removed - simply push the button on the side of the clutch.  
(Fits 7mm or smaller diameter pull rod)

## SWING LOCK CLUTCH



### SLC08

This allows the top hi-hat cymbal to float more freely, maximizing the natural resonance of the cymbals.  
(Fits 6.3mm diameter pull rod)

## SECURITY CLUTCH



### CLO8

Having your hi-hat clutch come loose is now a thing of the past with TAMA's Security Clutch. When the T-bolt is tightened, bottom lock nut and top section press on the rod for complete security.  
(Fits 6.3mm diameter pull rod)

## HI-HAT TENSION RODS



### HH9053/HH905D3S

Tension Rod w/ Plastic Nut (M6)

HH9053 (Long / 500mm (19 11/16")  
HH905D3S (Short / 350mm (13 3/4"))

## REMOTE HI-HAT STAND CABLE

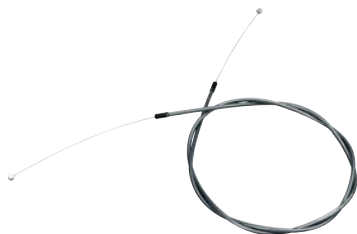

### HH905RH2L/HH905RH2S

Exchangeable Cable for HH905RH

HH905RH2L (Long / 2,300mm (90 1/2")  
HH905RH2S (Short / 1,200mm (47 1/4"))

## HI-HAT CLUTCH FELT WASHERS



### CLO813P

(2pcs/pack)

## QUICK-LOCK TOM BRACKET



### MQMPTCH

(for tom tom/Chrome)  
-Quick and easy setup in position  
-Enhanced resonance with rubber lining

## QUICK-LOCK TOM BRACKET



### MQMPTBN

(for tom tom/Black Nickel)  
-Quick and easy setup in position  
-Enhanced resonance with rubber lining

## QUICK-LOCK TOM BRACKET



### MQMPFCH

(for floor tom/Chrome)  
-Quick and easy setup in position  
-Enhanced resonance with rubber lining

## QUICK-LOCK TOM BRACKET



### MQMPFBN

(for floor tom/Black Nickel)  
-Quick and easy setup in position  
-Enhanced resonance with rubber lining

## SOUND FOCUS PAD -for Cocktail-JAM-



### SFP530

Bass Drum Mute for Cocktail-JAM kits

## DRUM STICKS

TAMA drum sticks are molded under strict quality control standards from carefully selected wood materials and are renowned for their consistent high quality.

### TRADITIONAL SERIES STICK -Japanese Oak-

#### 7A

MADE IN JAPAN

Diameter: 13mm (0.510")  
Length: 390mm (15 3/8")  
Tip Style: 7A



### TRADITIONAL SERIES STICK -Japanese Oak-

#### 5A

MADE IN JAPAN

Diameter: 14mm (0.550")  
Length: 406mm (16")  
Tip Style: 5A



### TRADITIONAL SERIES STICK -Japanese Oak-

#### 8A

MADE IN JAPAN

Diameter: 14mm (0.550")  
Length: 406mm (16")  
Tip Style: 8A



### TRADITIONAL SERIES STICK -Japanese Oak-

#### 5B

MADE IN JAPAN

Diameter: 15mm (0.590")  
Length: 406mm (16")  
Tip Style: 5B



## OAK LAB SERIES -Smash-

### OLSM

MADE IN JAPAN

Weight and balance for huge power.

Diameter: 15mm (0.590")  
Length: 419mm (16 1/2")  
Tip Style: Acorn



## OAK LAB SERIES -Resonator-

### OLRE

MADE IN JAPAN

Heavy for rich tones. Quick rebound.

Diameter: 15.25mm (0.600")  
Length: 410mm (16 5/32")  
Tip Style: Arrow



## OAK LAB SERIES -Fast Blast-

### OLFA

MADE IN JAPAN

(Natural / Uncoated)

Modified 5A for more speed. Large tip and Oak enhances volume.

Diameter: 14mm (0.550")  
Length: 406mm (16")  
Tip Style: Large Ball



## OAK LAB SERIES -Swingin'-

### OLSW

MADE IN JAPAN

Oak provides a bright cymbal tone and enhanced cross stick sound.

Diameter: 12.75mm (0.500")  
Length: 403mm (15 7/8")  
Tip Style: Oval



## OAK LAB SERIES -Full Balance-

### OLFU

MADE IN JAPAN

Weighted for accuracy and control.

Diameter: 14.5mm (0.570")  
Length: 406mm (16")  
Tip Style: True Round



## REDZONE -Japanese Oak-

### 5ARZ

MADE IN JAPAN

(Silver Logo)

Diameter: 14mm (0.550")  
Length: 419mm (16 1/2")  
Tip Style: 5A (Nylon)



## REDZONE -Japanese Oak-

### 5BRZ

MADE IN JAPAN

(Silver Logo)

Diameter: 15mm (0.590")  
Length: 419mm (16 1/2")  
Tip Style: 5B (Nylon)



## RHYTHMIC FIRE -Japanese Oak-

### 7AF

MADE IN JAPAN

(Natural)

Diameter: 13mm (0.510")  
Length: 390mm (15 3/8")  
Tip Style: 7A



## RHYTHMIC FIRE -Japanese Oak-

### 5AF

MADE IN JAPAN

(Natural)

Diameter: 14mm (0.550")  
Length: 406mm (16")  
Tip Style: 5A



## RHYTHMIC FIRE -Japanese Oak-

### 5BF

MADE IN JAPAN

(Natural)

Diameter: 15mm (0.590")  
Length: 406mm (16")  
Tip Style: 5B





## SUEDE-GRIP DRUM STICKS -Japanese Oak-

### 5ASG

**NEW** **MADE IN JAPAN**

(SUEDE-GRIP Finish)

Diameter : 14mm (0.550")  
Length : 406mm (16")  
Tip Style : 5A



## SUEDE-GRIP DRUM STICKS -Japanese Oak-

### 5BSG

**NEW** **MADE IN JAPAN**

(SUEDE-GRIP Finish)

Diameter : 15mm (0.590")  
Length : 406mm (16")  
Tip Style : 5B



## DIRK VERBEUREN MODEL -Japanese Oak-

### ODVM

**MADE IN JAPAN**

Dirk Verbeuren (MEGADETH)

Diameter: 16mm (0.630")  
Length: 406mm (16")



## JEREMY COLSON MODEL -American Hickory-

### HJCS

**MADE IN JAPAN**

Jeremy Colson (Steve Vai)

Diameter: 16.5mm (0.649")  
Length: 422mm (16.6")



## MARIO DUPLANTIER MODEL -American Hickory-

### HMD

**MADE IN JAPAN**

Mario Duplantier (Gojira)

Diameter: 16.5mm (0.649")  
Length: 432mm (17")



## ALEX RÜDINGER MODEL -American Hickory-

### HRUDI

**MADE IN JAPAN**

Alex Rüdinger

Diameter: 16mm (0.630")  
Length: 416mm (16 3/8")  
Non-Slipping Lacquer Finish



## ANUP SASTRY MODEL -American Hickory-

### HAS

**MADE IN JAPAN**

Anup Sastry

Diameter: 16mm (0.630")  
Length: 432mm (17")



## RHYTHM MATE SERIES STICK -Hickory-

### HRM2B

Diameter: 16mm (0.630")  
Length: 406mm (16")



## RHYTHM MATE SERIES STICK -Hickory-

### HRM5A

Diameter: 14mm (0.550")  
Length: 406mm (16")



## RHYTHM MATE SERIES STICK -Hickory-

### HRM5B

Diameter: 15mm (0.590")  
Length: 406mm (16")



## RHYTHM MATE SERIES STICK -Hickory-

### HRM7A

Diameter: 13.5mm (0.530")  
Length: 394mm (15 1/2")



## RHYTHM MATE SERIES STICK -Maple-

### MRM2B

Diameter: 16mm (0.630")  
Length: 406mm (16")



## RHYTHM MATE SERIES STICK -Maple-

### MRM5A

Diameter: 14mm (0.550")  
Length: 406mm (16")



## RHYTHM MATE SERIES STICK -Maple-

### MRM5B

Diameter: 15mm (0.590")  
Length: 406mm (16")



## RHYTHM MATE SERIES STICK -Maple-

### MRM7A

Diameter: 13.5mm (0.530")  
Length: 394mm (15 1/2")





---

 tamadrums  TAMAofficial  officialtamadrums  @TAMAofficial

**[www.tama.com](http://www.tama.com)**

1726 Winchester Road, Bensalem, PA 19020 • U.S.A.  
Actual product colors may not exactly be the same as the one shown on the catalog photos due to lighting and photo resolution.  
All specifications are subject to change without notice.

©2021 TAMA DRUMS All rights reserved. (U)