



## Borough of Doylestown Building and Zoning Department

215.345.4140

### FACT SHEET #2 – DECK INFORMATION

#### **BACKGROUND**

The provisions of the PAUCC, ICC Property Maintenance Code, and the Borough of Doylestown Code of Ordinance shall control the design and installation of decks. Installation or expansion of decks and patios requires a permit.

**DEFINITIONS** Deck – An exterior floor system supported on at least two opposing sides by an adjoining structure and/or posts, piers, or other independent supports.

#### **PERMIT REQUIREMENTS**

Installation of any deck or patio requires a permit. Visit [www.doylestownborough.net](http://www.doylestownborough.net) for more information.

#### **GENERAL INFORMATION**

1. All wood in contact with the ground, embedded in concrete in direct contact with the ground or embedded in concrete exposed to the weather that supports permanent structures intended for human occupancy shall be approved pressure-preservative treated wood suitable for ground contact use.
2. All framing members shall be Hem-Fir #2 or Southern pine #2 pressure treated or better and shall be used in determining spans in the deck design.
3. All screws and nails shall be hot-dipped zinc-coated galvanized steel, stainless steel, silicon bronze or copper. All steel bolts shall be of one-half-inch diameter or larger.
4. All of the following inspections are required during construction of deck:
  - Footing inspections are required before the concrete is poured. Footings must be at a minimum depth of 36 inches. All holes must be cleaned, dry and free from loose dirt.
  - Framing inspections must be completed before the decking may be attached, unless otherwise noted.
  - Final inspection shall be scheduled when all construction of the deck has been completed.
5. Decks may not be occupied until all inspections have been completed and a final approval has been given by the Building Code Official.

**FOOTINGS**

All footers must be a minimum of 36" below grade and bear on solid, undisturbed soil. Deck footings closer than 5'-0" to any existing exterior house wall may not extend below the foundation of the house. See below for size and thickness. Do not construct footings over utility lines or enclosed meters. Call PA One Call (1-800-242-1776) before you dig.

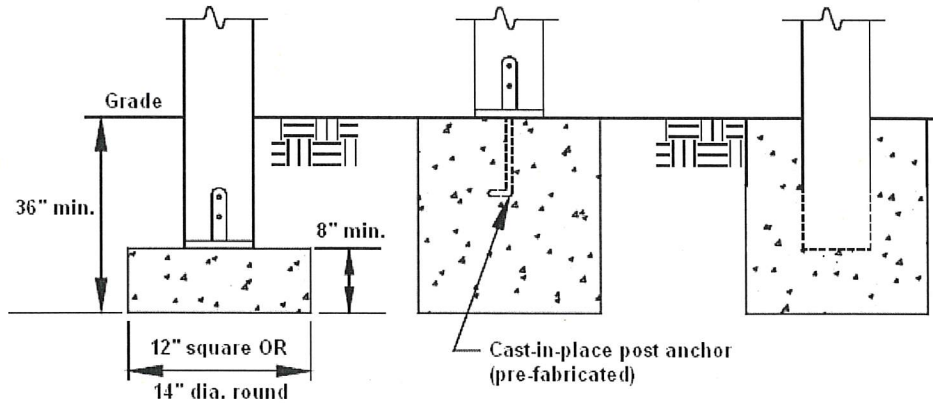

Figure 1

**JOIST SIZING AND SPAN**

Joist spans shall be in accordance with Table 1 and the Figures below. These spans are based on a 40 psf live load, a 10 psf dead load and a deflection of  $L/\Delta = 360$ .

TABLE 1: FLOOR JOIST SPANS FOR COMMON LUMBER SPECIES

Joist Spacing (inches)	Species of Lumber	2x6 (ft.-in.)	2x8 (ft.-in.)	2x10 (ft.-in.)	2x12 (ft.-in.)
12	Hem-Fir #2	10-0	13-2	16-10	20-4
	Southern Pine #2	10-9	14-2	18-0	21-9
16	Hem-Fir #2	9-1	12-0	15-2	17-7
	Southern Pine #2	9-9	12-10	16-1	18-10
19.5	Hem-Fir #2	8-7	11-3	13-10	16-1
	Southern Pine #2	9-2	12-1	14-8	17-2
24	Hem-Fir #2	7-11	10-2	12-5	14-4
	Southern Pine #2	8-6	11-0	13-1	15-5

Cantilever spans shall comply with Table 2 below. Note that you must support the joists from uplift loads by approved fasteners, such as joist hangers.

TABLE 2: CANTILEVER SPANS FOR FLOOR JOISTS

Member Size	Spacing	Max Cantilever Span Based on $\leq 30$ psf Ground Snow Load	Uplift Force at Backspan Support in lbs.
2x8	12"	42"	139
2x8	16"	36"	151
2x10	12"	61"	164
2x10	16"	53"	180

FACT SHEET #2 – DECK SHEET

2x10	24"	43"	212
2x12	16"	72"	228
2x12	24"	58"	279

- a. Ratio of backspan to cantilever span shall be at least 2:1.
- b. Connections capable of resisting the indicated uplift force shall be provided at the backspan support.

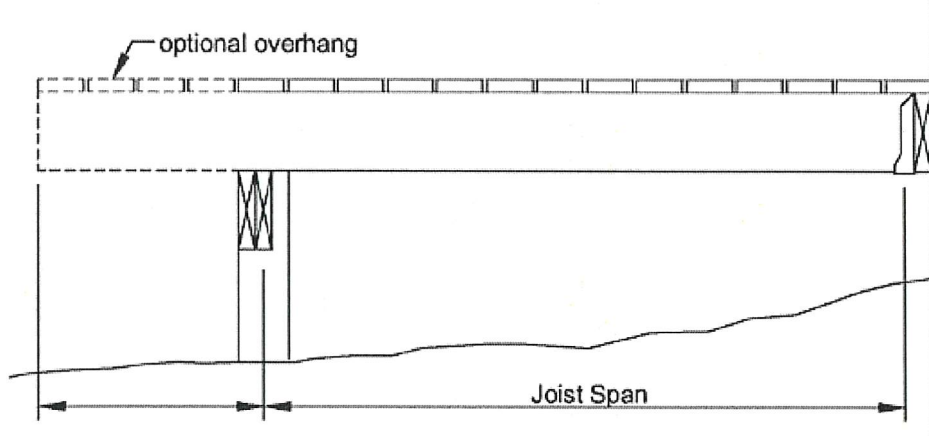

Figure 2

**BEAM SIZE AND ASSEMBLY REQUIREMENTS**

Beams shall not exceed values in Table 3 below. The ends of each beam shall have not less than 1.5 inches of bearing on wood.

TABLE 3: GIRDER SPANS

Size	2- 2x4	2- 2x6	2- 2x8	2- 2x10	2- 2x12	3- 2x8	3- 2x10	3- 2x12	4- 2x8	4- 2x10	4- 2x12
Span	3'-6"	5'-5"	6'-10"	8'-5"	9'-9"	8'-4"	10'-6"	12'-2"	9'-2"	11'-8"	14'-1"

**DECK FRAMING PLAN**

A framing plan is required when applying for a deck permit. The plan should show the deck from a bird's-eye-view indicate the necessary elements of framing. This includes joist sizes and layout, beam size and spans, footer placement and ledger board attachments, ect. See Figures 3 and 4 below for framing plan details.

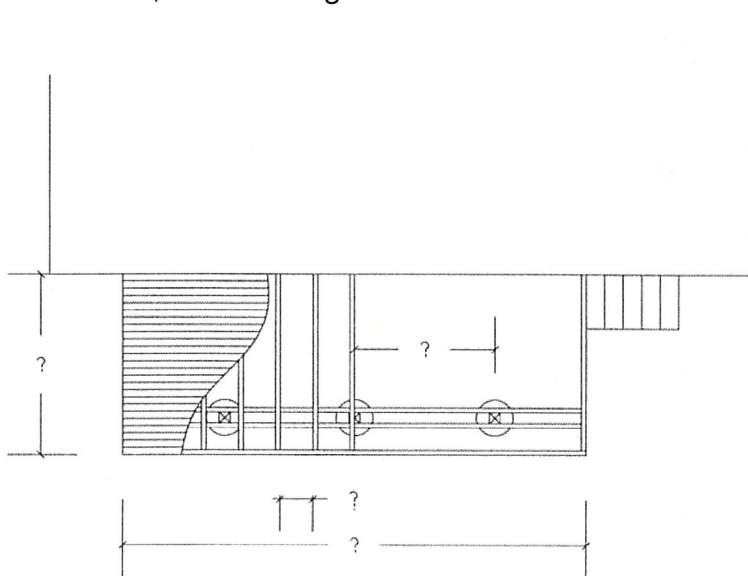

Figure 3

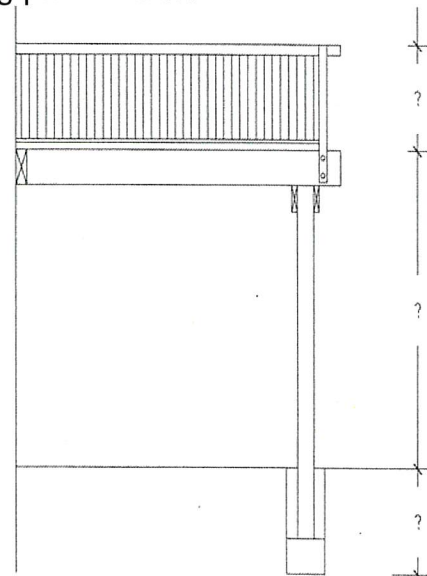

Figure 4



**JOIST-TO-BEAM CONNECTIONS**

All joists shall be properly attached to each beam and ledger with appropriate means of fasteners. The use of toenails, hurricane clips or joist hangers are permitted. NOTE: THE USE OF SCREWS TO IS NOT PERMITTED. See Figure 5 for available options.

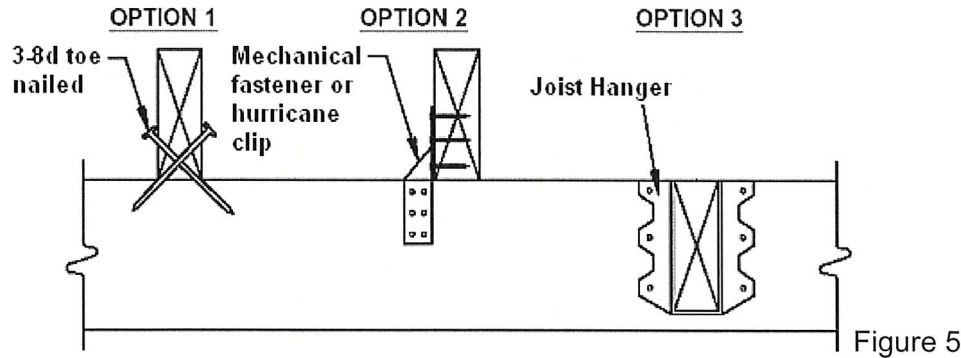

Figure 5

**JOIST HANGERS**

All joist hangers (shown in Figure 6) shall be used for their intended manufacturing size and made of No. 20 gage steel. Joist hangers shall be corrosion-resistant or shall be protected by galvanizing, electroplating, or with approved steel primer. Nails (10d by 1-1/2" complying with ASTM F 1667) must be used to fasten all components together. NOTE: YOU MAY NOT ALTER THE HANGER TO ACCOMMODATE OTHER ANGLES OR CONDITIONS.

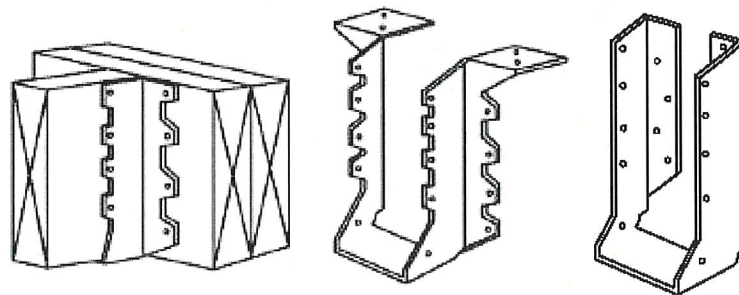

Figure 6

**LEDGER ATTACHMENT**

The attachment of a ledger board shall be through the use of a 1/2" diameter lag bolt, thru-bolt or anchor of sufficient size to extend through your ledger and rim joist. The removal of siding and installation of flashing is required between the house and the ledger. NOTE: YOU MAY NOT ATTACH LEDGER BOARDS TO EXISTING CANTILEVERS, OPEN WEB TRUSSES OR BRICK VENEER. If these conditions occur, the deck must be freestanding.

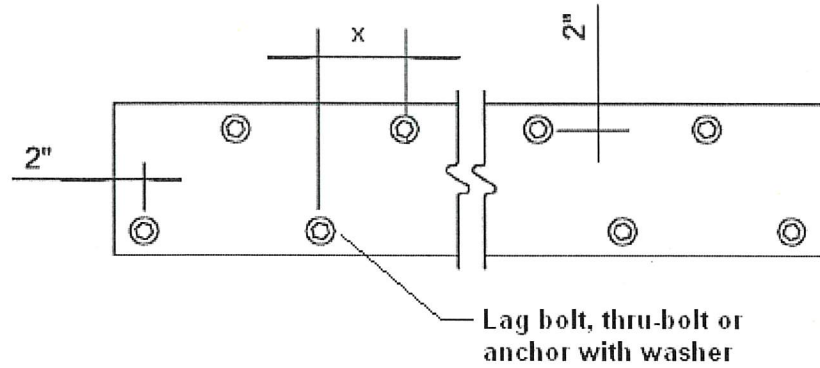

Figure 7

Refer to Table 4 for spacing on ledger fasteners.

TABLE 4:  
**FASTENER SPACING FOR A SOUTHERN PINE OR HEM-FIR DECK LEDGER  
 AND A 2-INCH NOMINAL SOLID-SAWN SPRUCE-PINE-FIR BAND JOIST<sup>c,f,g</sup>**  
 (Deck Live Load = 40 psf, Deck Dead Load = 10 psf)

Joist Span	6'-0" and Less	6'-1" to 8'-0"	8'-1" to 10'-0"	10'-1" to 12'-0"	12'-1" to 14'-0"	14'-1" to 16'-0"	16'-1" to 18'-0"
<b>Connection Details</b>	<b>On-Center Spacing of Fasteners<sup>d,e</sup></b>						
1/2" diameter lag screw with 15/32" maximum sheathing <sup>a</sup>	30	23	18	15	13	11	10
1/2" diameter bolt with 15/32" maximum sheathing	36	36	34	29	24	21	19
1/2" diameter bolt with 15/32" maximum sheathing and 1/2" stacked washers <sup>b,h</sup>	36	36	29	24	21	18	16

For SI: 1 inch = 25.4, 1 foot = 304.8 mm. 1 pound per square foot = 0.0479 kN/m<sup>2</sup>.

- a. The tip of the lag screw shall fully extend beyond the inside face of the band joist.
- b. The maximum gap between the face of the ledger board and face of the wall sheathing shall be 1/2".
- c. Ledgers shall be flashed to prevent water from contacting the house band joist.
- d. Lag screws and bolts shall be staggered in accordance with Section R502.2.2.1.1.
- e. Deck ledger shall be minimum 2x8 pressure-preservative-treated No.2 grade lumber, or other approved materials as established by standard engineering practice.
- f. When solid-sawn pressure-preservative-treated deck ledgers are attached to engineered wood products (structural composite lumber rimboard or laminated veneer lumber), the ledger attachment shall be designed in accordance with accepted engineering practice.
- g. A minimum 1 by 9-1/2 Douglas Fir laminated veneer lumber rimboard shall be permitted in lieu of the 2-inch nominal band joist.
- h. Wood structural panel sheathing, gypsum board sheathing or foam sheathing not exceeding 1 inch in thickness shall be permitted. The maximum distance between the face of the ledger board and the face of the band joist shall be 1 inch.

The following Figures 8-10 provide examples of the correct installation procedures for different types of ledger board fasteners.

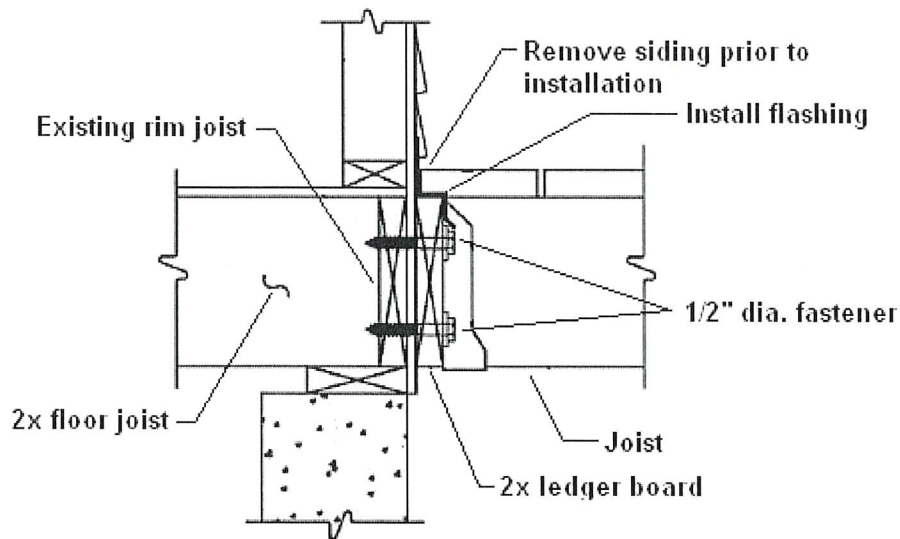

Figure 8: Lag or thru-bolt

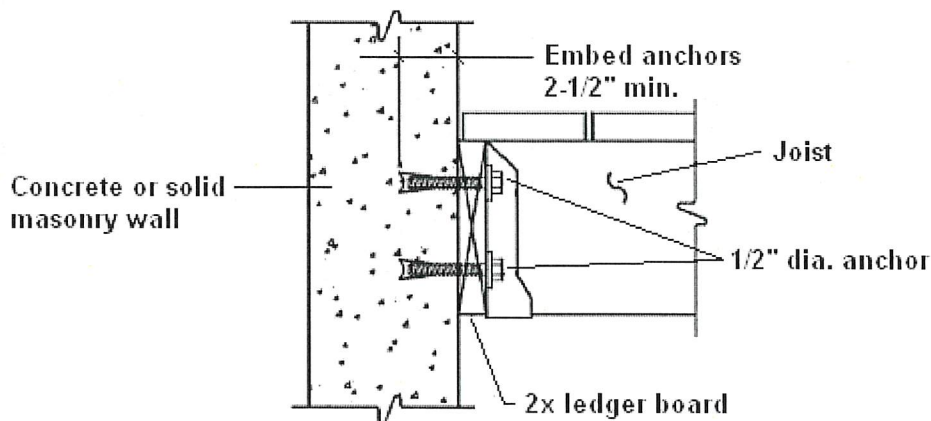

Figure 9: Anchor into concrete

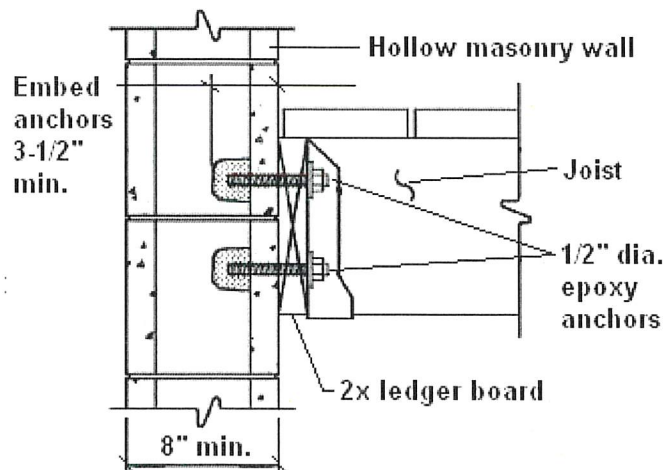

Figure 10: Anchor into hollow masonry

## ATTACHMENT AROUND A BAY WINDOW OR CHIMNEY

Attaching the ledger to a house overhang, chimney or bay window shall be prohibited. Use an alternate deck framing plan to achieve structural stability without fastening to the projection (see Figure 11 for example).

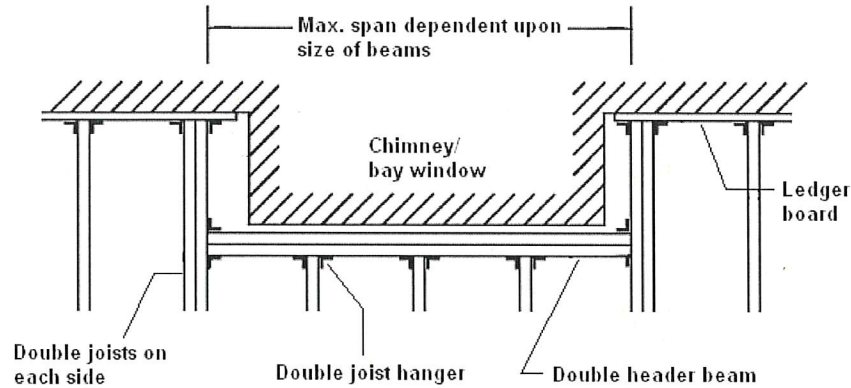

Figure 11

## GUARD REQUIREMENTS

Porches, balconies, ramps or raised floor surfaces located more than 30" above the floor or grade below shall have guards not less than 36" in height. Open sides of stairs with a total rise of more than 30" shall not have guards less than 34" measured vertically from the tread nosing.

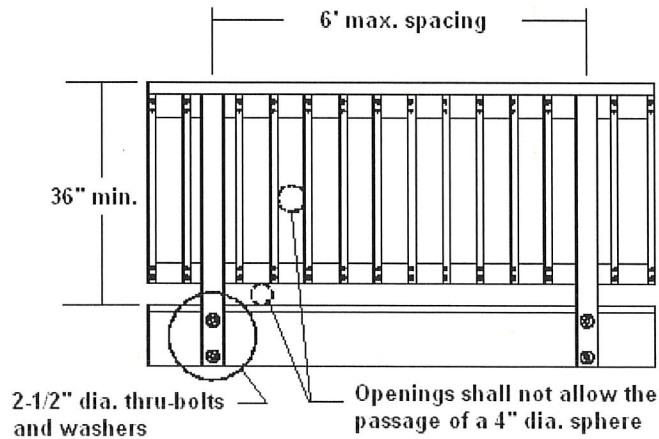

Figure 12

Required guards on open sides of stairways, raised floor areas, balconies and porches shall have intermediate rails or ornamental closures which do not allow the passage of a sphere 4" or more in diameter. Exceptions: (see Figure 13)

1. The triangular openings formed by the riser, tread and bottom rail at the open side of the stairway are permitted to be of such size that a 6" sphere cannot pass through.
2. Openings for required guards on the sides of stair treads shall not allow the passage of a sphere 4-3/8" in diameter.



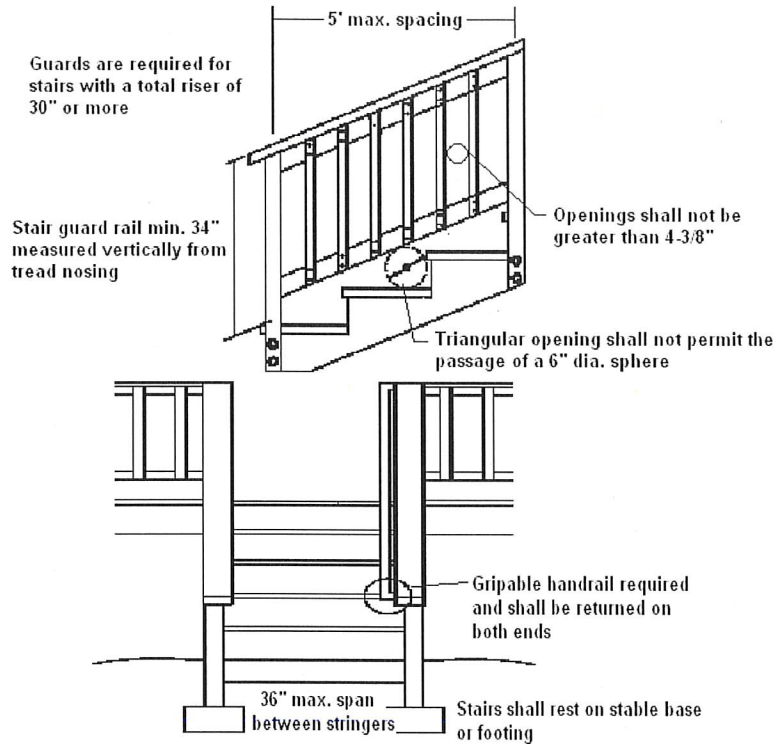

Figure 13

The maximum riser height shall be 8-1/4" measured vertically between leading edges of adjacent treads. The minimum tread depth shall be 9" measured horizontally from beginning to end of tread. Handrails may not be less than 34" nor greater than 38" above tread nosing and must be continuous throughout the run of stairs.

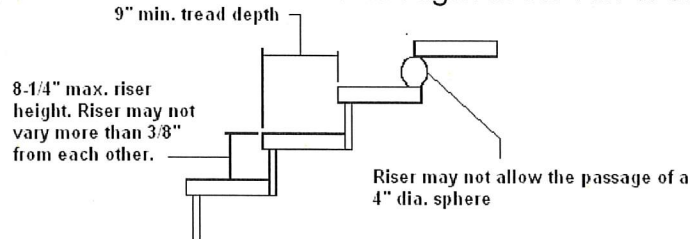

Figure 14: Stair Requirements

### **STAIR HANDRAIL REQUIREMENTS**

Handrails shall be provided on at least one side of each continuous run of treads or flight with four or more risers. Handrails shall be located between 34" and 38" measured vertically from the sloped plane adjoining tread nosing (see Figure 13).

Handrail shall comply with one of the following options:



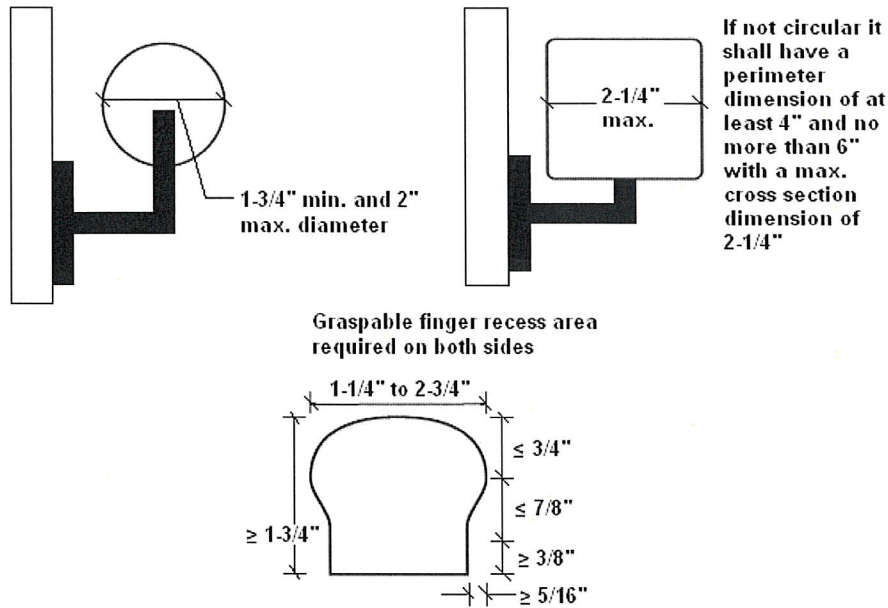

Figure 15

**DECKING REQUIREMENTS**

Decking material shall be 2"x6" or 5/4" lumber or other approved composite matter. Any synthetic or composite material shall be approved by the building official, only after an ICC Evaluation Report of the particular product. The reports may be found at [http://www.icc-es.org/Evaluation\\_Reports/index.shtml](http://www.icc-es.org/Evaluation_Reports/index.shtml) by searching the manufacturer or product name. Decking shall not have a span that would compromise a 40 lb. per square foot load capacity.

**Permit Required for Deck or Patio Installation** A permit is required for the installation of a deck or patio. Failure to secure a permit before installation may impose violations, fines and necessitate the removal of installed structures.

**The information provided in this guide is intended only to assist residents in understanding the code requirements for decks.**