

Fill in this form and print out. You cannot save completed form, so make a copy for your records.

# Borough of Doylestown

## Department of Building and Zoning Permit Application for Sidewalk/Curb/Apron

Hours of Operation  
Monday - Friday  
8:30 a.m. - 4:30 p.m.

### Background:

The Borough of Doylestown requires that prior to any new sidewalk construction or repair that involves removal of existing surface down to the base; the property owner shall acquire a Sidewalk/Curb/Apron Permit from the Department of Building and Zoning, located at 10 Doyle Street. There is a \$25 fee for this permit. All construction/repair work shall be done according to the Borough of Doylestown City Sidewalk Ordinance specifications.

### Sidewalk Requirements:

- Sidewalks shall be constructed of four (4) inch thick, three thousand (3,000) pound per square inch Portland cement concrete poured on a compacted base. Sidewalks shall be four (4) feet in width and allow for a four foot planting strip between the curb and the sidewalk; provided however, that the Borough of Doylestown may approve a greater or lesser width for the purpose of conformity of new or replacement sidewalks with existing connecting sidewalks.
- Sidewalks shall have a scored joint at 4 foot intervals and a  $\frac{1}{8}$  inch expansion joint every 24 lineal feet.

### Driveway Requirements:

- Curb cuts are required. Flared cuts should be used to gradual transition between the sidewalk and the ramp. Returned curbs should only be used in areas that pedestrians would not normally travel such as planting strips.
- Driveways and aprons shall be constructed of four (4) inch thick, three thousand five hundred (3,500) pound per square inch Portland cement concrete poured on a compacted base. Number 4 reinforcing bars shall be laid in the curb cut. Use 4 bars in two rows of 2 bars each.
- Curb cut ramps shall be at least 12 foot wide for single car drives, 24 foot wide for double car drives.
- Sidewalks shall be four (4) feet in width and allow for a four foot planting strip between the curb and the sidewalk; provided however, that the Borough of Doylestown may approve a greater or lesser width for the purpose of conformity of new or replacement sidewalks with existing connecting sidewalks.

The Borough of Doylestown may, upon the recommendation of an engineer and a finding of unique or special circumstances with respect to a particular sidewalk or portion thereof, may alter or add to said specifications as deemed necessary for proper construction, reconstruction, replacement or repair.

### Standard Inspection Requirements:

- Prepour (forms in place before concrete is poured)
- Final

Fill in this form and print out. You cannot save completed form, so make a copy for your records.

# Borough of Doylestown

Department of Building and Zoning

Permit Application for

Sidewalk/Curb/Apron

Hours of Operation  
Monday - Friday  
8:30 a.m. - 4:30 p.m.

Bring or mail this form with a check for \$25 made out to "The Borough of Doylestown" to the Borough of Doylestown, Building and Zoning office at 57 West Court Street If you received a sidewalk notice, contact us first for fee information.

**PROPERTY INFORMATION:**

Property Address:	Tax ID Number:
Property Owner Name:	Owner Phone:
Property Owner Address:	

**CONTRACTOR'S INFORMATION:**

Company Name:	Phone:
Company Address:	Email:
Contact Name :	Contact Cell Phone:
If Owner is doing the work complete Affidavit of Exemption from Proof of Worker's Compensation Form	

**DESCRIPTON OF WORK:**

**LOCATION OF WORK:**

Length of Curb:	Length of Driveway:	Length of Sidewalk:
Materials To Be Used:		
List any trees or embedded objects: (Example tree, parking meters, signs, valves, hydrants)		
Description of Work To be Performed: (Example: Remove and replace 50 square feet of sidewalk)		
Applicant Signature:		Date:

**APPLICATION PROCESSING RECORD** (Borough Office Use Only)

Amount Paid:	Date:	Check Number:		
Payor:	Received by:			
Date of Review:	Reviewer Signature:			
Permit is:	Granted	Denied	Other:	Reason:
Date of Review:	Comments/Conditions:			
Applicant notified by:			On Date:	
Permit Number Issued:			On Date:	

- All work must be completed within 120 days of the issue date. Applicant is responsible for scheduling all inspections. Application for this permit means that you agree to comply with all building codes, manufacturer's specifications, industry standards, state laws, and zoning ordinances as set by the Borough of Doylestown.
- To schedule inspections call the number below.  
Please schedule inspections at least 48 hours in advance of requested time.

10 Doyle Street  
Doylestown, PA  
18901

Phone: (215) 345-4140  
DoylestownBorough.net

# Borough of Doylestown

## Department of Building and Zoning

### Permit Application for Sidewalk/Curb/Apron

Hours of Operation  
Monday - Friday  
8:30 a.m. - 4:30 p.m.

#### Driveway with Planting Strip between the Curb and Sidewalk (Not to Scale)

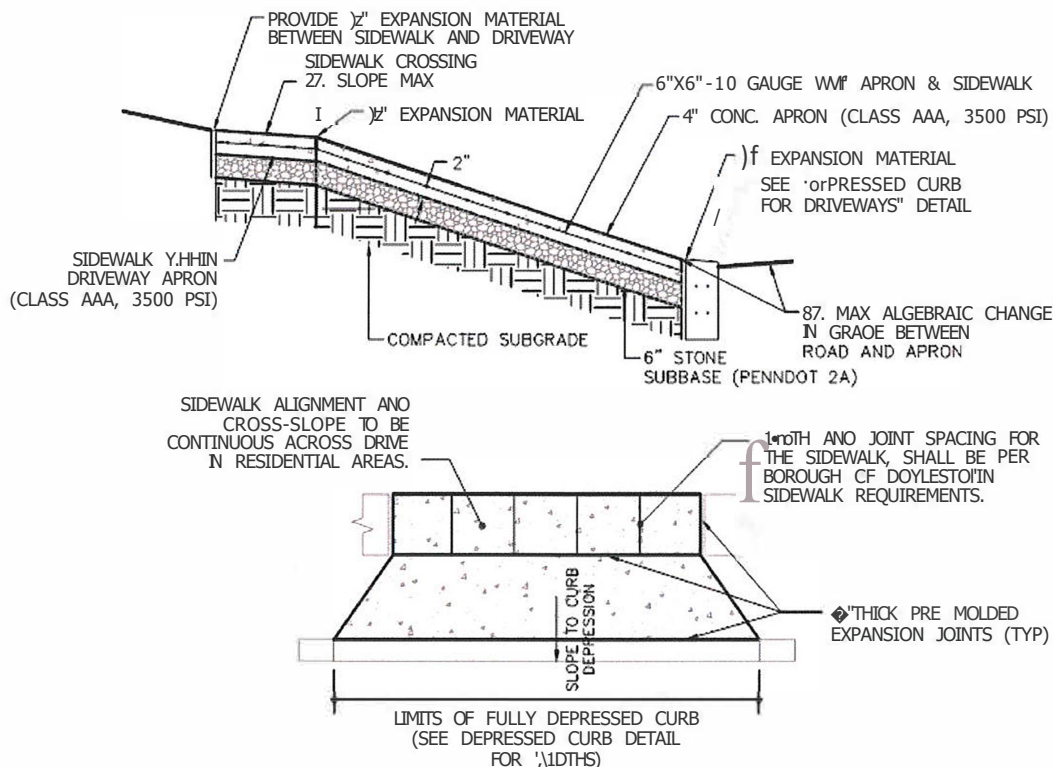

#### **Sidewalk Requirements:**

- Sidewalks shall be constructed of four (4) inch thick, three thousand (3,000) pound per square inch Portland cement concrete poured on a compacted base. Sidewalks shall be four (4) feet in width and allow for a four foot planting strip between the curb and the sidewalk; provided however, that the Borough of Doylestown may approve a greater or lesser width for the purpose of conformity of new or replacement sidewalks with existing connecting sidewalks.
- Sidewalks shall have a scored joint at 4 foot intervals and a 1/2 inch expansion joint every 24 lineal feet.

#### **Driveway Requirements:**

- Curb cuts are required. Flared cuts should be used to gradual transition between the sidewalk and the ramp. Returned curbs should only be used in areas that pedestrians would not normally travel such as planting strips.
- Driveways and aprons shall be constructed of four (4) inch thick, three thousand five hundred (3,500) pound per square inch Portland cement concrete poured on a compacted base. Number 4 reinforcing bars shall be laid in the curb cut. Use 4 bars in two rows of 2 bars each.
- Curb cut ramps shall be at least 12 foot wide for single car drives, 24 foot wide for double car drives.
- Sidewalks shall be four (4) feet in width and allow for a four foot planting strip between the curb and the sidewalk; provided however, that the Borough of Doylestown may approve a greater or lesser width for the purpose of conformity of new or replacement sidewalks with existing connecting sidewalks.

The Borough of Doylestown may, upon the recommendation of an engineer and a finding of unique or special circumstances with respect to a particular sidewalk or portion thereof, may alter or add to said specifications as deemed necessary for proper construction, reconstruction, replacement or repair.

# Borough of Doylestown

## Department of Building and Zoning

### Permit Application for Sidewalk/Curb/ Apron

Hours of Operation  
Monday - Friday  
8:30 a.m. - 4:30 p.m.

#### Driveway without Planting Strip between the Curb and Sidewalk (Not to Scale)

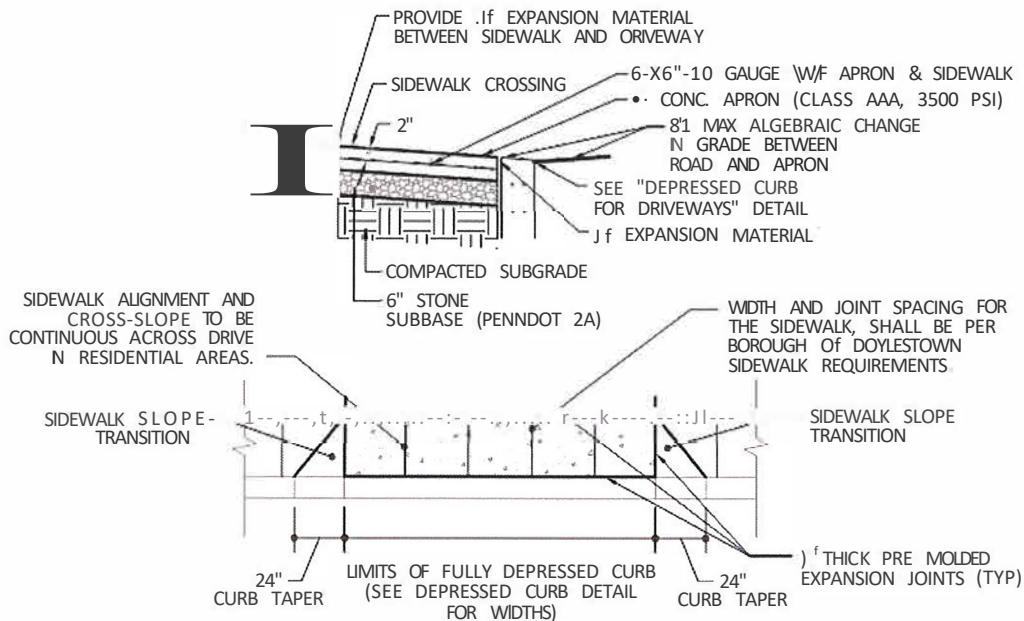

#### **Sidewalk Requirements:**

- Sidewalks shall be constructed of four (4) inch thick, three thousand (3,000) pound per square inch Portland cement concrete poured on a compacted base. Sidewalks shall be four (4) feet in width and allow for a four foot planting strip between the curb and the sidewalk; provided however, that the Borough of Doylestown may approve a greater or lesser width for the purpose of conformity of new or replacement sidewalks with existing connecting sidewalks.
- Sidewalks shall have a scored joint at 4 foot intervals and a 1/2 inch expansion joint every 24 lineal feet.

#### **Driveway Requirements:**

- Curb cuts are required. Flared cuts should be used to gradual transition between the sidewalk and the ramp. Returned curbs should only be used in areas that pedestrians would not normally travel such as planting strips.
- Driveways and aprons shall be constructed of four (4) inch thick, three thousand five hundred (3,500) pound per square inch Portland cement concrete poured on a compacted base. Number 4 reinforcing bars shall be laid in the curb cut. Use 4 bars in two rows of 2 bars each.
- Curb cut ramps shall be at least 12 foot wide for single car drives, 24 foot wide for double car drives.
- Sidewalks shall be four (4) feet in width and allow for a four foot planting strip between the curb and the sidewalk; provided however, that the Borough of Doylestown may approve a greater or lesser width for the purpose of conformity of new or replacement sidewalks with existing connecting sidewalks.

The Borough of Doylestown may, upon the recommendation of an engineer and a finding of unique or special circumstances with respect to a particular sidewalk or portion thereof, may alter or add to said specifications as deemed necessary for proper construction, reconstruction, replacement or repair.



**Borough of Doylestown**  
**Department of Building and Zoning**  
**Permit Application for**  
**Sidewalk/Curb/ Apron**

Hours of Operation Monday - Friday 8:30 a.m. - 4:30 p.m.
--

**Depressed Concrete Curb Detail (Not to Scale)**

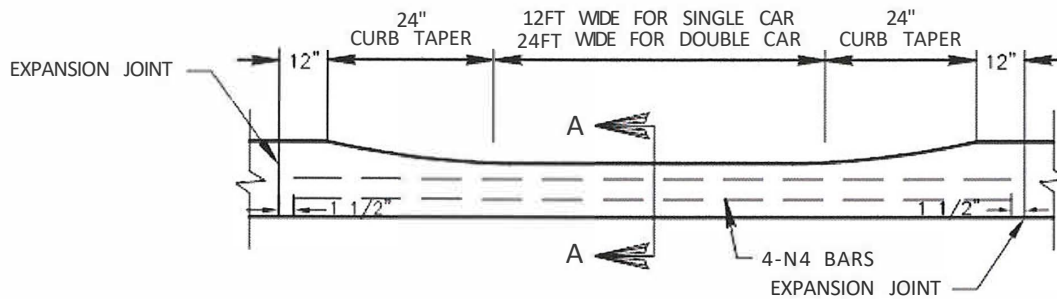

**PLAN VIEW**

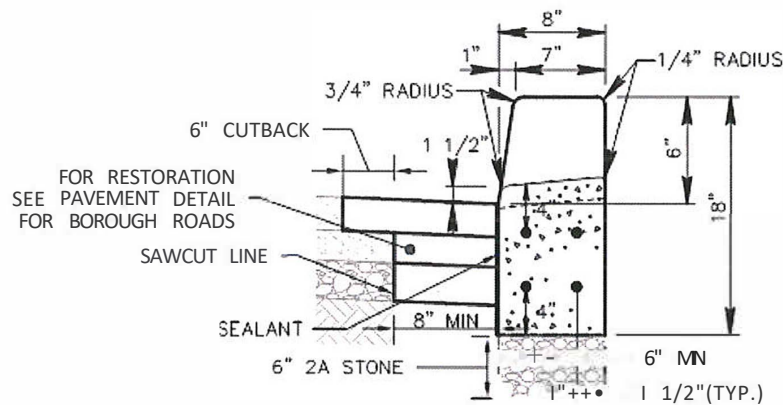

**SECTION A-A**

**Driveway Requirements:**

- Curb cuts are required. Flared cuts should be used to gradual transition between the sidewalk and the ramp. Returned curbs should only be used in areas that pedestrians would not normally travel such as planting strips.
- Driveways and aprons shall be constructed of four (4) inch thick, three thousand five hundred (3,500) pound per square inch Portland cement concrete poured on a compacted base. Number 4 reinforcing bars shall be laid in the curb cut. Use 4 bars in two rows of 2 bars each.
- Curb cut ramps shall be at least 12 foot wide for single car drives, 24 foot wide for double car drives.
- 24 inch curb tapers shall be painted yellow with oil based paint.

The Borough of Doylestown may, upon the recommendation of an engineer and a finding of unique or special circumstances with respect to a particular sidewalk or portion thereof, may alter or add to said specifications as deemed necessary for proper construction, reconstruction, replacement or repair.

**Borough of Doylestown**  
**Department of Building and Zoning**  
**Permit Application for**  
**Sidewalk/Curb/ Apron**

Hours of Operation Monday - Friday 8:30 a.m. - 4:30 p.m.
--

**Pavement Detail for Borough Roads (Not to Scale)**

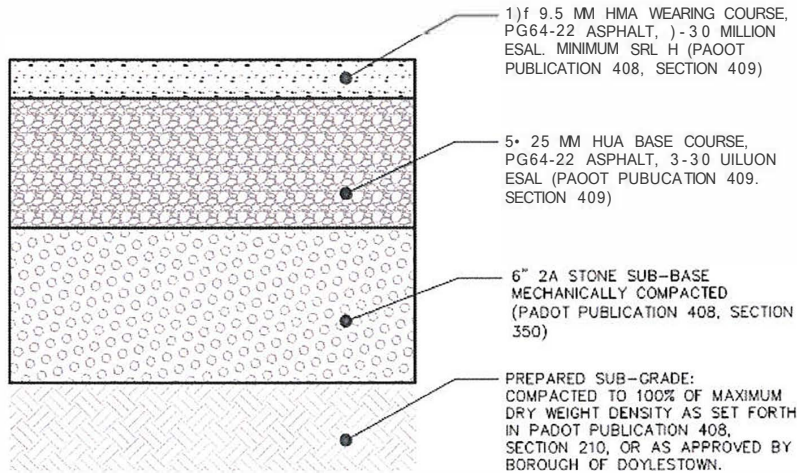

**Pavement Detail for Residential Driveways (Not to Scale)**

