

Borough of Doylestown

Department of Building and Zoning

Permit Application for Sidewalk/Curb/Apron

Background:

The Borough of Doylestown requires that prior to any new sidewalk construction or repair that involves removal of existing surface down to the base; the property owner shall acquire a Sidewalk/Curb/Apron Permit from the Department of Building and Zoning, located at 10 Doyle Street. There is a \$25 fee for this permit plus a \$4.50 state fee. All construction/repair work shall be done according to the Borough of Doylestown City Sidewalk Ordinance specifications.

Sidewalk Requirements:

- Sidewalks shall be constructed of three thousand (3,000) pound per square inch Portland cement concrete poured over a six (6) inch thick layer of stone on a compacted base. Sidewalks shall be four (4) feet in width and allow for a four-foot planting strip between the curb and the sidewalk; provided, however, that the Borough of Doylestown may approve a greater or lesser width for the purpose of conformity of new or replacement sidewalks with existing connecting sidewalks.
- Sidewalks shall have a scored joint at 4-foot intervals and a ½ inch expansion joint every 24 lineal feet.

Driveway Requirements:

- Curb cuts are required. Flared cuts should be used to gradual transition between the sidewalk and the ramp. Returned curbs should only be used in areas that pedestrians would not normally travel such as planting strips.
- Driveways and aprons shall be constructed of six (6) inch thick, three thousand five hundred (3,500) pound per square inch Portland cement concrete poured on a compacted base. Number 4 reinforcing bars shall be laid in the curb cut. Use 4 bars in two rows of 2 bars each.
- Curb cut ramps shall be at least 12 foot wide for single car drives, 24 foot wide for double car drives.
- Sidewalks shall be four (4) feet in width and allow for a four foot planting strip between the curb and the sidewalk; provided however, that the Borough of Doylestown may approve a greater or lesser width for the purpose of conformity of new or replacement sidewalks with existing connecting sidewalks.

The Borough of Doylestown may, upon the recommendation of an engineer and a finding of unique or special circumstances with respect to a particular sidewalk or portion thereof, may alter or add to said specifications as deemed necessary for proper construction, reconstruction, replacement or repair.

Standard Inspection Requirements:

- Prepour (forms in place before concrete is poured)
- Final

Borough of Doylestown

Department of Building and Zoning

Permit Application for Sidewalk/Curb/Apron

PROPERTY INFORMATION:

Property Address: _____	Tax ID Number: _____
Property Owner Name: _____	Owner Phone: _____
Property Owner Address: _____	

CONTRACTOR'S INFORMATION:

Company Name: _____	Phone: _____
Company Address: _____	Borough Registration # _____
Contact Name : _____	Contact Cell Phone: _____
If Owner is doing the work complete Affidavit of Exemption from Proof of Worker's Compensation Form	

DESCRIPTON OF WORK:

Length of Curb: _____	Length of Driveway: _____	Length of Sidewalk: _____
Materials To Be Used: _____		
List any trees or embedded objects: (Example tree, parking meters, signs, valves, hydrants)		
Description of Work To be Performed: (Example: Remove and replace 50 square feet of sidewalk)		
Applicant Signature: _____		Date: _____

APPLICATION PROCESSING RECORD (Borough Office Use Only)

Amount Paid: _____	Date: _____	Check Number: _____
Payor: _____	Received by: _____	
Date of Review: _____	Reviewer Signature: _____	
Permit is: Granted Denied Other: _____	Reason: _____	
Date of Review: _____	Comments/Conditions: _____	
Applicant notified by: _____	On Date: _____	
Permit Number Issued: _____	On Date: _____	

- All work must be completed within 120 days of the issue date. Applicant is responsible for scheduling all inspections. Application for this permit means that you agree to comply with all building codes, manufacturer's specifications, industry standards, state laws, and zoning ordinances as set by the Borough of Doylestown.
- To schedule inspections call the number below.
- Please schedule inspections at least 48 hours in advance of requested time.

Borough of Doylestown

Department of Building and Zoning

Permit Application for Sidewalk/Curb/Apron

Hours of Operation
Monday - Friday
8:30 a.m. - 4:30 p.m.

Driveway with Planting Strip between the Curb and Sidewalk (Not to Scale)

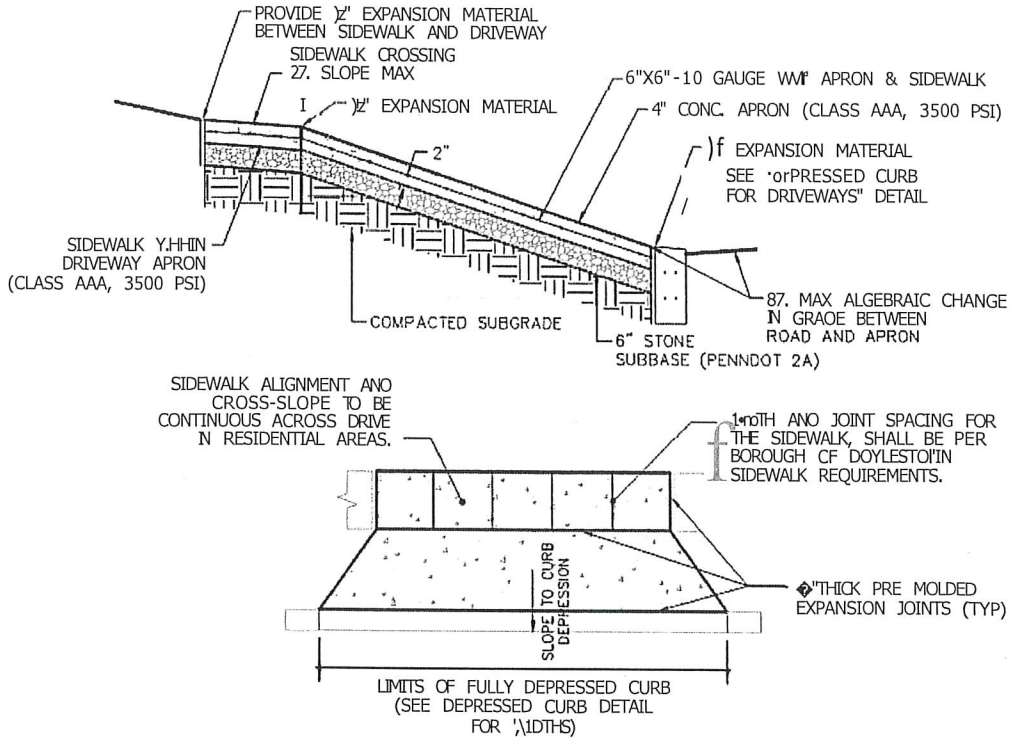

Sidewalk Requirements:

- Sidewalks shall be constructed of six (6) inch thick, three thousand (3,000) pound per square inch Portland cement concrete poured on a compacted base. Sidewalks shall be four (4) feet in width and allow for a four foot planting strip between the curb and the sidewalk; provided however, that the Borough of Doylestown may approve a greater or lesser width for the purpose of conformity of new or replacement sidewalks with existing connecting sidewalks.
- Sidewalks shall have a scored joint at 4 foot intervals and a 1/2 inch expansion joint every 24 lineal feet.

Driveway Requirements:

- Curb cuts are required. Flared cuts should be used to gradual transition between the sidewalk and the ramp. Returned curbs should only be used in areas that pedestrians would not normally travel such as planting strips.
- Driveways and aprons shall be constructed of six (6) inch thick, three thousand five hundred (3,500) pound per square inch Portland cement concrete poured on a compacted base. Number 4 reinforcing bars shall be laid in the curb cut. Use 4 bars in two rows of 2 bars each.
- Curb cut ramps shall be at least 12 foot wide for single car drives, 24 foot wide for double car drives.
- Sidewalks shall be four (4) feet in width and allow for a four foot planting strip between the curb and the sidewalk; provided however, that the Borough of Doylestown may approve a greater or lesser width for the purpose of conformity of new or replacement sidewalks with existing connecting sidewalks.

The Borough of Doylestown may, upon the recommendation of an engineer and a finding of unique or special circumstances with respect to a particular sidewalk or portion thereof, may alter or add to said specifications as deemed necessary for proper construction, reconstruction, replacement or repair.

Borough of Doylestown
Department of Building and Zoning
Permit Application for
Sidewalk/Curb/ Apron

Hours of Operation Monday - Friday 8:30 a.m. - 4:30 p.m.
--

Driveway without Planting Strip between the Curb and Sidewalk (Not to Scale)

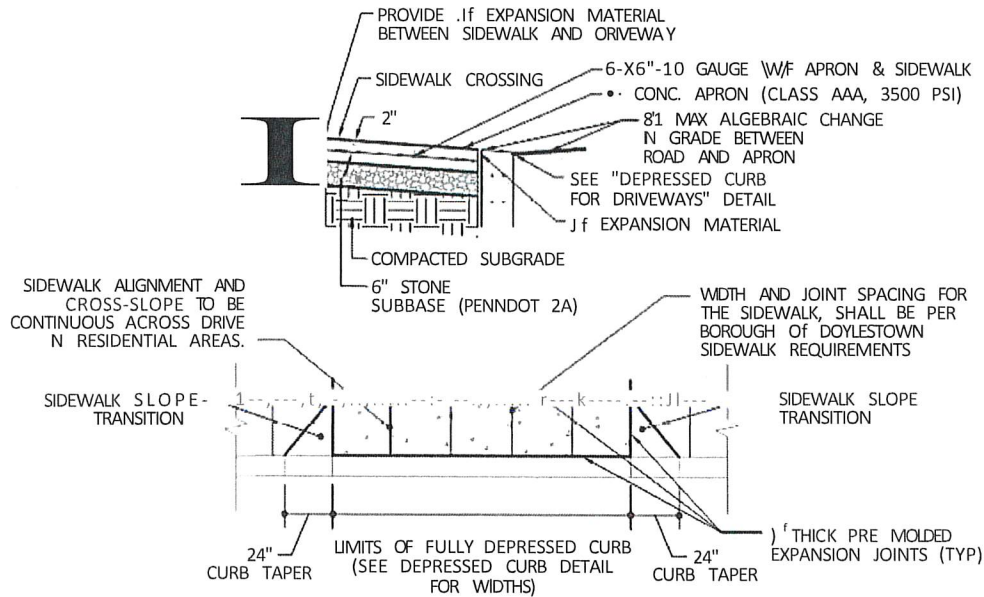

Sidewalk Requirements:

- Sidewalks shall be constructed of six (6) inch thick, three thousand (3,000) pound per square inch Portland cement concrete poured on a compacted base. Sidewalks shall be four (4) feet in width and allow for a four foot planting strip between the curb and the sidewalk; provided however, that the Borough of Doylestown may approve a greater or lesser width for the purpose of conformity of new or replacement sidewalks with existing connecting sidewalks.
- Sidewalks shall have a scored joint at 4 foot intervals and a 1/4 inch expansion joint every 24 lineal feet.

Driveway Requirements:

- Curb cuts are required. Flared cuts should be used to gradual transition between the sidewalk and the ramp. Returned curbs should only be used in areas that pedestrians would not normally travel such as planting strips.
- Driveways and aprons shall be constructed of six (6) inch thick, three thousand five hundred (3,500) pound per square inch Portland cement concrete poured on a compacted base. Number 4 reinforcing bars shall be laid in the curb cut. Use 4 bars in two rows of 2 bars each.
- Curb cut ramps shall be at least 12 foot wide for single car drives, 24 foot wide for double car drives.
- Sidewalks shall be four (4) feet in width and allow for a four foot planting strip between the curb and the sidewalk; provided however, that the Borough of Doylestown may approve a greater or lesser width for the purpose of conformity of new or replacement sidewalks with existing connecting sidewalks.

The Borough of Doylestown may, upon the recommendation of an engineer and a finding of unique or special circumstances with respect to a particular sidewalk or portion thereof, may alter or add to said specifications as deemed necessary for proper construction, reconstruction, replacement or repair.

Borough of Doylestown
Department of Building and Zoning
Permit Application for
Sidewalk/Curb/ Apron

Hours of Operation Monday - Friday 8:30 a.m. - 4:30 p.m.
--

Depressed Concrete Curb Detail (Not to Scale)

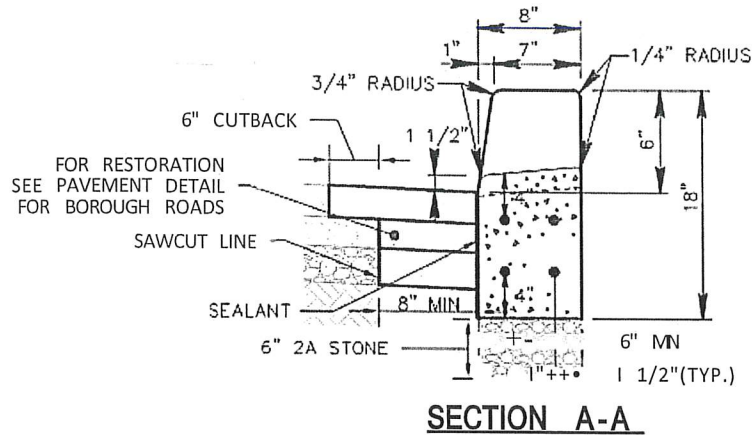
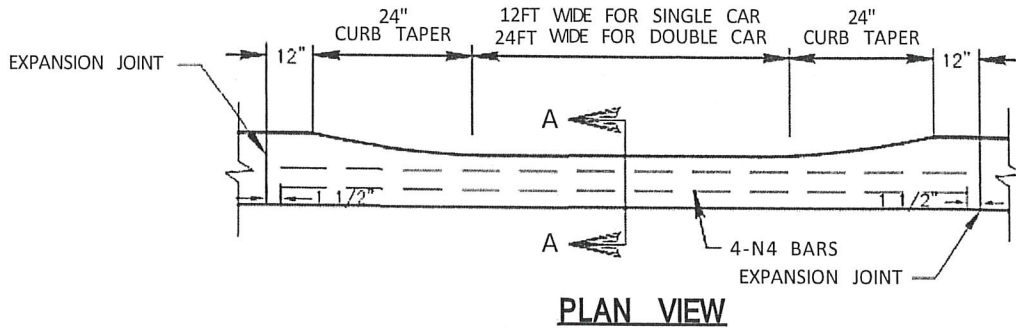

Driveway Requirements:

- Curb cuts are required. Flared cuts should be used to gradual transition between the sidewalk and the ramp. Returned curbs should only be used in areas that pedestrians would not normally travel such as planting strips.
- Driveways and aprons shall be constructed of six (6) inch thick, three thousand five hundred (3,500) pound per square inch Portland cement concrete poured on a compacted base. Number 4 reinforcing bars shall be laid in the curb cut. Use 4 bars in two rows of 2 bars each.
- Curb cut ramps shall be at least 12 foot wide for single car drives, 24 foot wide for double car drives.
- 24 inch curb tapers shall be painted yellow with oil based paint.

The Borough of Doylestown may, upon the recommendation of an engineer and a finding of unique or special circumstances with respect to a particular sidewalk or portion thereof, may alter or add to said specifications as deemed necessary for proper construction, reconstruction, replacement or repair.

Borough of Doylestown
Department of Building and Zoning
Permit Application for
Sidewalk/Curb/ Apron

Hours of Operation Monday - Friday 8:30 a.m. - 4:30 p.m.
--

Pavement Detail for Borough Roads (Not to Scale)

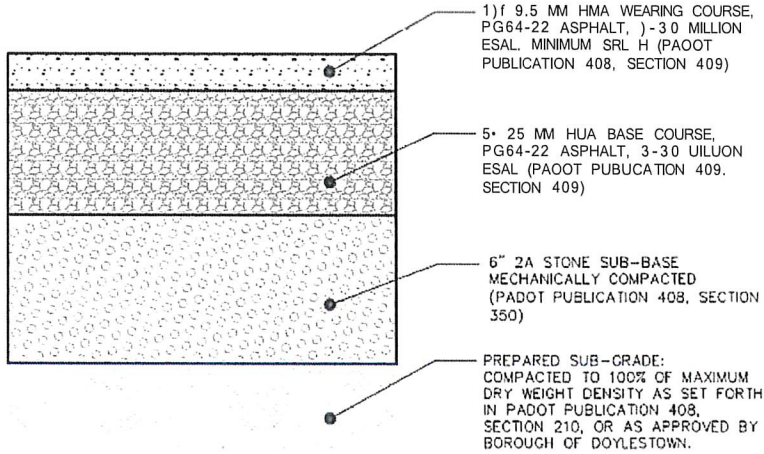

Pavement Detail for Residential Driveways (Not to Scale)

