

A Low Loss, Remote Radar Target Simulator (LRTS)

by Joe Mazzochette, General Manager, Eastern OptX, Inc.

This article describes a new tool developed to test high performance, phased array radar systems. Historically, radar testing was accomplished using laboratory-based target generators, simple delay lines, or signal synthesizers. Laboratory testing is convenient and inexpensive. It avoids any issues associated with radiating signals that might require regulatory approval, and that the emission of which may be otherwise undesirable.

Field testing can be accomplished using fixed reflectors positioned in the radar antenna far-field or with moving targets. The benefit of the latter approach is that the entire radar can be tested in the presence of real-world phenomena including multipath, intentional and unintentional interferers, and land, sea, and air targets. The LRTS (Low-loss Radar Target Simulator) system presented here incorporates the comprehensive advantages of field testing with the speedy, and economical laboratory tests.

A Modified Field Test

The LRTS is similar to a conventional far-field radar range test as shown in Figure 1.

The tower in the system in Figure 1 is positioned in the far-field of the radar antenna. The tower system may be used to generate a target signal for the radar, or it may be used as a repeater. As a repeater, the system will pick up the signal broadcast from the radar using an antenna on the tower top. The

signal is then sent to a repeater at the tower base, which typically delays and attenuates the signal. It is then sent to a second antenna (or via an isolated path to a single Rx/Tx antenna) and broadcast back to the radar.

This method is quite common and will include all of the normal environmental artifacts such as multipath, moving targets, and

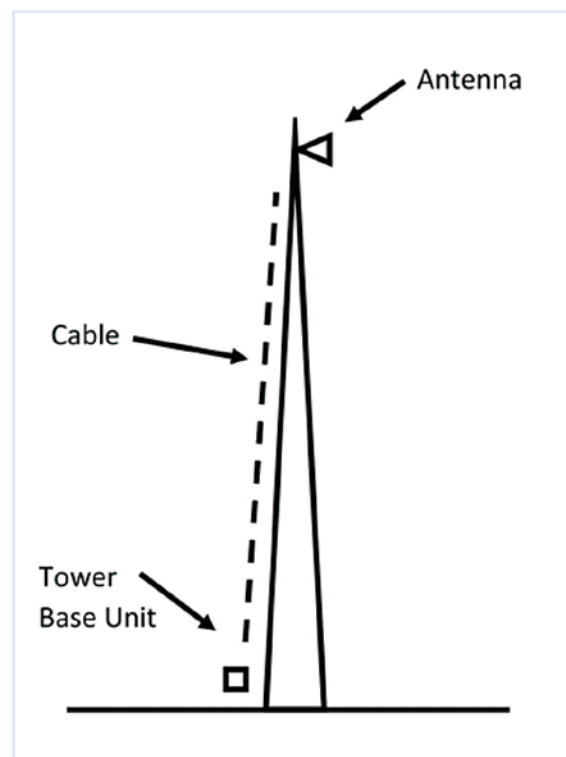

Figure 1: Conventional far-field radar range test

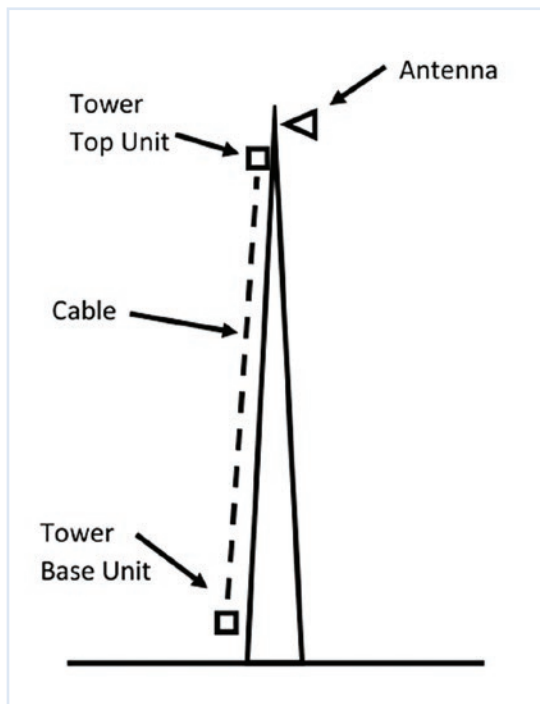

Figure 2: LRTS with tower-top mounted Optical Transceivers (Tower Top Unit)

other in-band transmissions present in the area. This approach is an improvement over the laboratory approach. Using a lab-based system allows for reproduction of some artifacts offered on more complicated target generation systems. However, it cannot predict all of the effects possible in the field range test—the effects of antenna and associated RF hardware are excluded.

It should be mentioned that costly anechoic chamber testing can be practical—particularly on high frequency systems where the chamber size is manageable, the use of a chamber will allow for the inclusion of antenna effects, but not the environmental artifacts.

The solution discussed in this paper is a modified field test LRTS. The goal of this test is to reduce system losses and improve the Signal to Noise Ratio (SNR) so that the baseline radar performance can be measured in the presence of real-world effects.

There are two methods by which the SNR is improved—both involve the reduction in system loss. The first is to use optical fiber transmission lines to create the spatial radar signal transit times associated with the different target distances. These transit times can be fixed or variable, depending on the test requirement. The variable delay is typically step-wise, consisting of a sequence of typically binary steps, which may be combined to produce 2^n different target distances, where (n) is the number of binary steps.

The choice of optical fiber provides a considerable reduction in signal loss compared to free space loss. For example, an X-Band radar signal reflected from a target 10 km from the radar will be attenuated by ~ 118 dB below the transmit signal (assuming 10 dB antenna gain). On the other hand, the same signal transmitted over fiber will only suffer about 6 dB with a noise figure of 13 dB (~19 dB SNR reduction).

The second SNR improvement is accom-

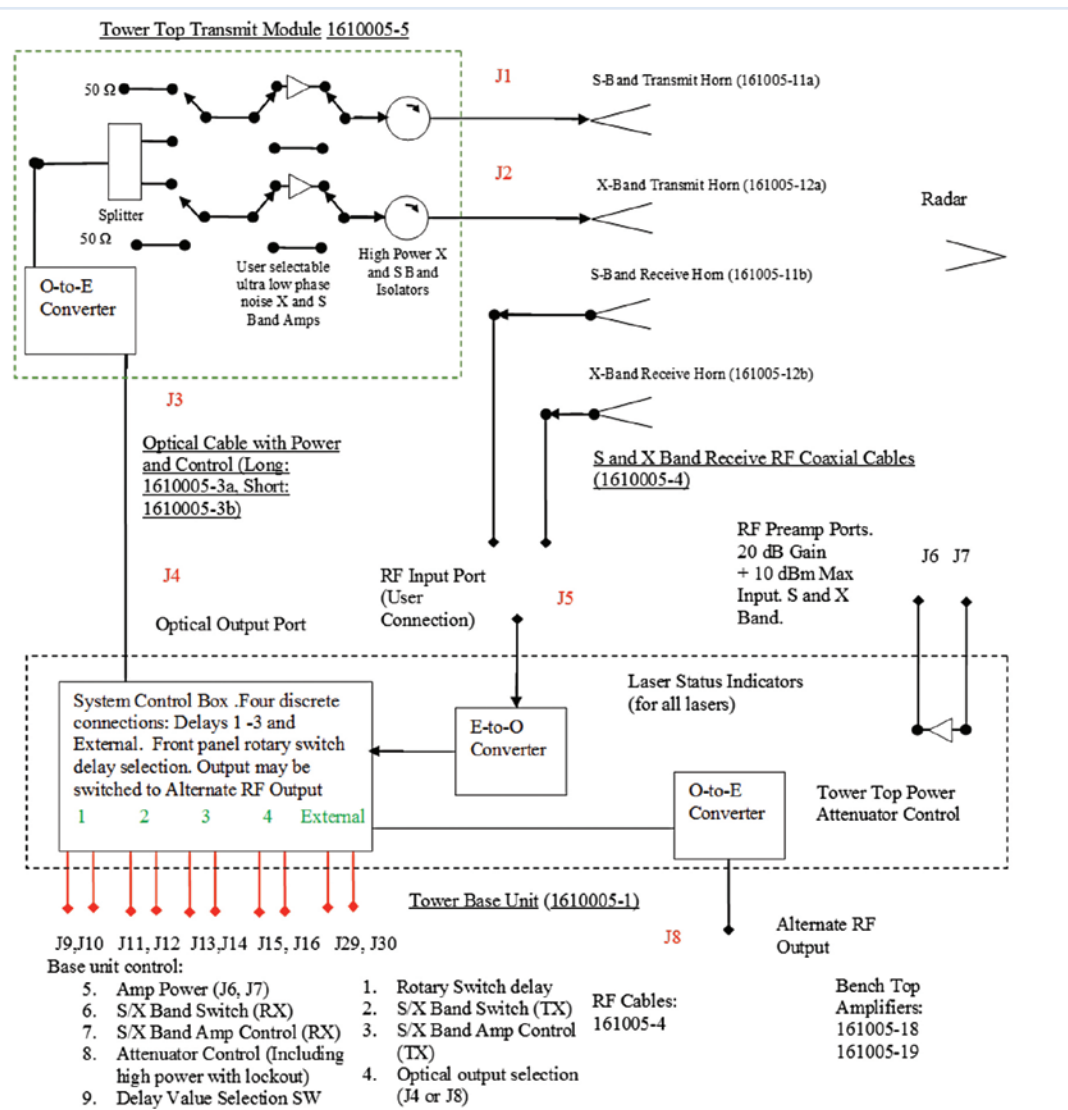

Figure 3: Typical block diagram for a broadband (0.1 – 18 GHz) system

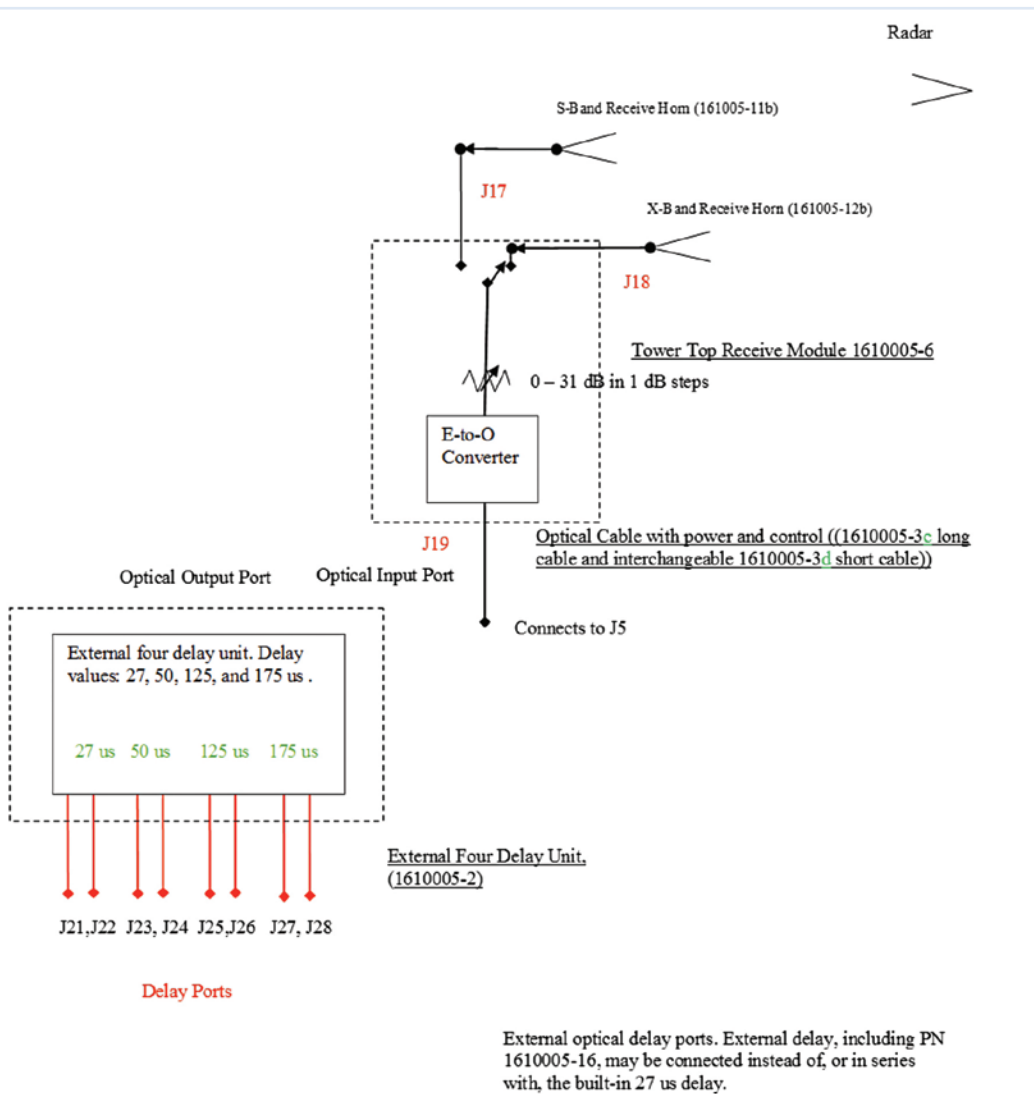

Figure 4: Image of the complete system hardware

plished by moving the optical fiber transceivers in proximity to the RF antennas. This reduces the RF cable needed to connect the LRTS to the Tx/Rx antenna at the top of the tower. For example, the RF cable loss for an X-Band radar with antennas mounted on a 150 foot tower will produce a total loss of ~45 dB (assuming a good, low loss coaxial cable). The loss for optical fiber over the same distance is ~0.2 dB.

Figure 2 shows the LRTS with tower-top mounted Optical Transceivers (Tower Top Unit). The Tower Base unit contains the optical time delays, Doppler generator, and propagation loss compensation.

Figure 3 shows a typical block diagram for a broadband (0.1 – 18 GHz) system.

Figure 3 also shows a manual system with optical fiber on the system output. RF cable loss is less critical in the RF input since the receive antenna is located in close proximity to the radar antenna. This LRTS also features user-selectable tower-top amplifiers along with isolators for protection. The target distance time delays are selectable for the base unit front panel.

Figure 4 shows an image of the complete system hardware.

Figure 5 shows a detailed view of the Tower Base Unit.

Figure 6 shows the radar target delay unit connected via optical cables to the Tower Base Control Unit. Rotary switch (SW2) is used to either bypass or select any of four target delays or an external delay.

Conclusion

The Eastern OptX 1100 Series Low-loss Radar Target Simulator (LRTS) offers a test environment that includes external environmental artifacts and complete system testing. It also includes the radar antenna and associated RF electronics, such as amplifiers, phase shifters, and the like.

The 1100 Series LRTS presented here provides an economical and effective tool

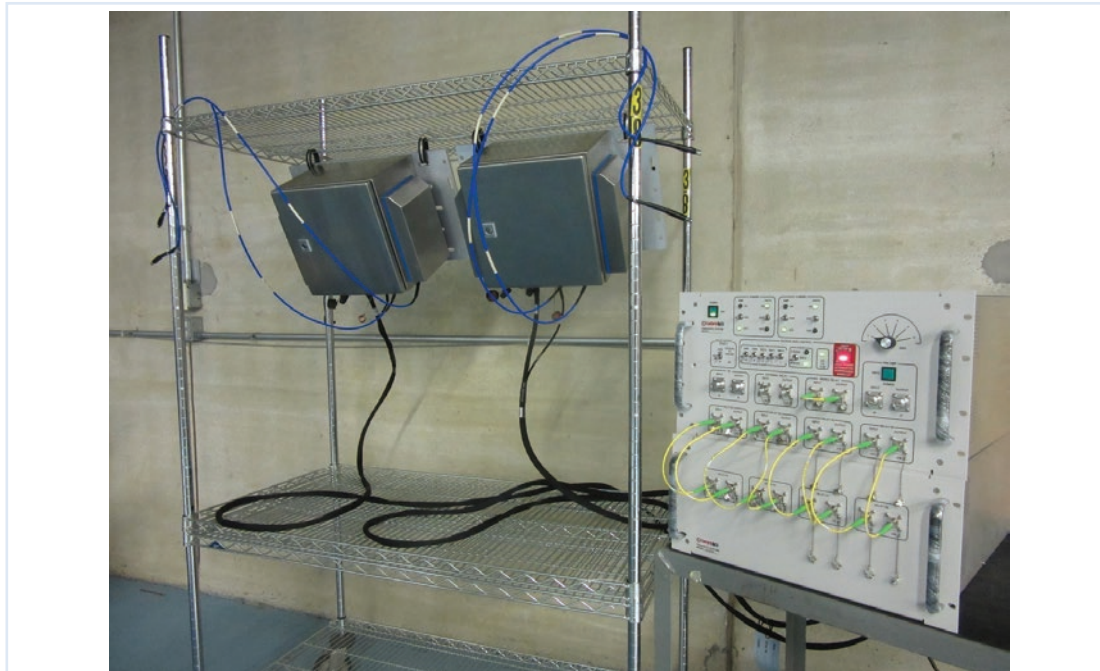

Figure 5: Detailed view of the Tower Base Unit

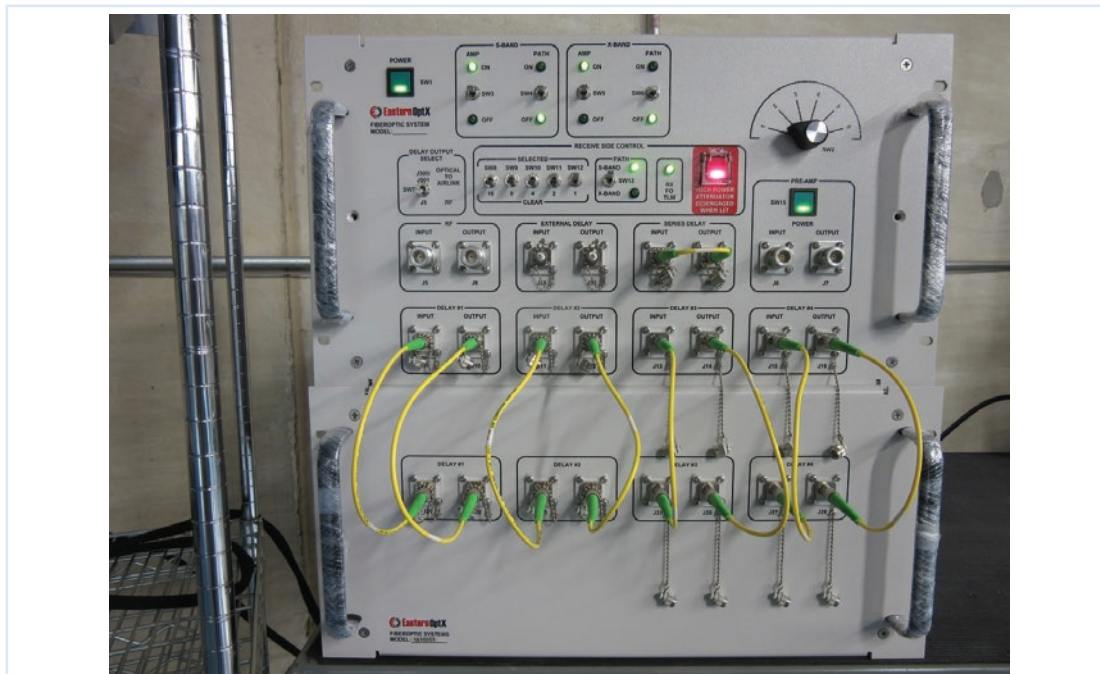

Figure 6: Radar target delay unit connected via optical cables to the Tower Base Control Unit

for rapid laboratory and/or range-based testing. It helps designers to determine the baseline system performance by reducing

the total loss below the free-space loss. 

• EASTERN OPTX, INC. •