

## Right Angle Cable Mount TNC Connector

RS Stock number 457-232

### Assembly Instructions

1) Strip the cable to the dimensions shown, cutting the centre conductor at approximately 30° angle. Take care not to nick the centre conductor or braid. Cutting the centre conductor at 30° facilitates easy entry of the conductor into the connector.

A = 6,4mm  
B = 12,7mm

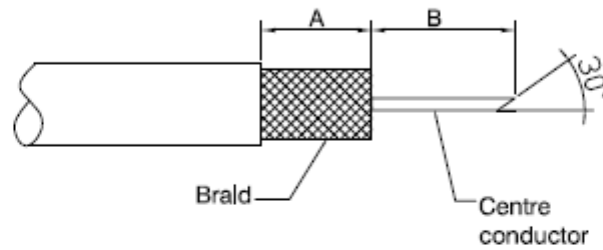

2) Twist the braid in a clockwise direction so that a minimum of 1.0mm dielectric is shown. Make sure to avoid loose or stray strands that could cause short circuits.

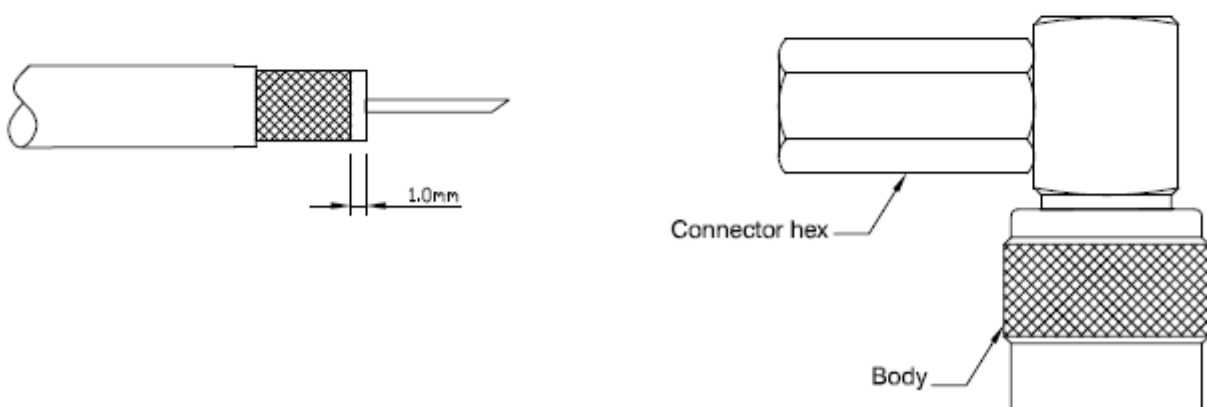

3) Insert the centre conductor into the guide hole in the rear insulator of the connector.

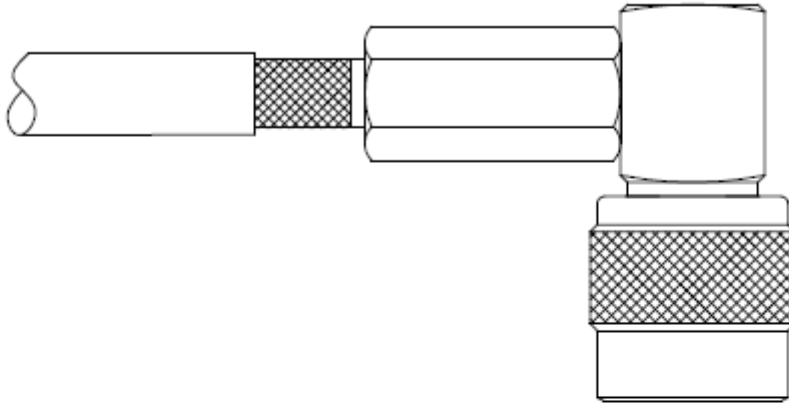

4) Firmly push the cable as far forward as possible and screw the connector hex back onto the cable in a clockwise direction until it stops.

