



COPPUS DOUBLE-DUTY™ HEAT KILLER

Powerful industrial fan for cooling products processes and personnel

MODEL/SPECIFICATIONS

ADJUSTABLE GUIDE VANES

Adjustable guide vanes create a number of airflow patterns from gentle breeze to jet blast. Most efficient air flow can be determined by positioning guide vanes during operation.

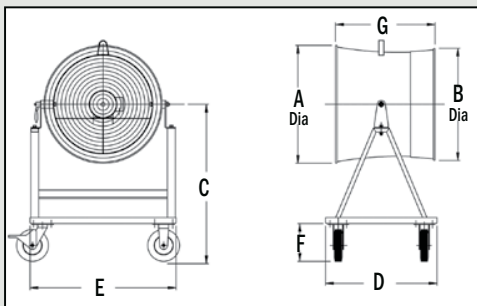

DESCRIPTION

With airflows up to 17,000 cfm (28,890 m³/hr) the Double-Duty™ Heat Killer (DDHK) is one of the most powerful and versatile portable air movers on the market today. The patented, adjustable guide vane design allows air flow control—from a gentle breeze for personnel cooling, to a concentrated jet blast for product and process cooling.

FEATURES / ADVANTAGES

- Adjustable guide vanes allow varied air movement from a gentle breeze to a jet blast
- Available in 24 in (610 mm) and 30 in (762 mm) models
- Available in floor stand or wall mount models
- Heavy-duty, rugged steel housing and frame
- Protective screens meet OSHA guidelines
- Available with TE and EP motors
- Hazardous location switches and motors meet NEC Class I, Division I, Group D and Class II, Division I, Groups F and G specifications
- Thermal overload protection on motors

**Note: EP plugs sold separately to meet local codes*

DIMENSIONS

FLOOR STAND DIMENSIONS

FAN SIZE	in/mm							NET WT lbs/kgs
	A	B	C	D	E	F	G	
24 in 610 mm	29.6 752	28.3 719	39.5 1,003	28.0 711	36.5 927	9.5 241	25.0 635	250 113
30 in 762 mm	36.8 935	33.4 848	39.5 1,003	28.0 711	36.5 927	9.5 241	28.0 711	340 154

TECHNICAL DATA

AIR VELOCITIES FPM (M/MIN) AT VARIOUS DISTANCES FROM FAN									
MODEL	10 ft 3 m		30 ft 9 m		50 ft 15 m		70 ft 21 m		90 ft 27 m
	JB	DF	JB	DF	JB	DF	JB	DF	JB
24K10D	1,675 508	670 203	840 255	375 114	560 170	280 85	350 106	230 70	185 56
30K30D	2,250 686	1,280 390	1,000 304	520 159	900 274	340 104	700 213	310 95	475 145

JB = jet blast
DF = diffused flow

FREE AIR DECIBEL LEVELS	
24K07D	79 dBA
24K10D	85 dBA
30K30D	92 dBA

PERFORMANCE SPECIFICATIONS						
MODEL	FAN SIZE		MOTOR		AIR VOLUME	
	in	mm	HP	rpm	cfm	m ³ /hr
24K07D	24	610	3/4	1,750	7,100	12,060
24K10D	24	610	1	1,750	9,500	16,140
30K30D	30	610	3	1,750	17,000	28,890

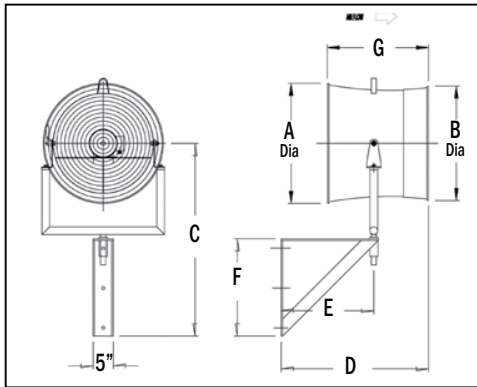

WALL MOUNT DIMENSIONS							
FAN SIZE	in/mm						
	A	B	C	D	E	F	G
24 in 610 mm	29.6 752	28.3 719	47.6 1208	36.4 925	22.9 582	24.0 610	25.0 635
30 in 762 mm	36.8 935	33.4 848	52.7 1338	39.6 1006	25.1 638	26.1 664	28.0 711

DDHK WALL MOUNT KIT

Easy retrofit wall mount kits are available for existing floor stand models; kits include wall bracket and fan U-bracket.

- Frees up valuable floor space
- Ensures permanent location
- Design permits 360 degree rotation with variable tilt up or down of 155 degrees (90 degrees down, 65 degrees up)