



Main

Range of product	Harmony Electromechanical Relays
Accessory / separate part category	Mounting accessory
Product or component type	Maintaining clamp
Product destination	RXM relay

Complementary

Accessory material	Plastic
Product compatibility	Socket RXZ (2 C/O) Socket RXZ (3 C/O) Socket RXZ (4 C/O)
Sale per indivisible quantity	10
Net weight	0.005 kg

Packing Units

Unit Type of Package 1	PCE
Number of Units in Package 1	1
Package 1 Height	2.500 cm
Package 1 Width	2.500 cm
Package 1 Length	6.000 cm
Package 1 Weight	3.800 g
Unit Type of Package 2	BB1
Number of Units in Package 2	10
Package 2 Height	4.500 cm
Package 2 Width	5.000 cm
Package 2 Length	10.000 cm
Package 2 Weight	38.000 g
Unit Type of Package 3	S01
Number of Units in Package 3	200
Package 3 Height	15.000 cm
Package 3 Width	15.000 cm
Package 3 Length	40.000 cm
Package 3 Weight	933.000 g

The information provided in this documentation contains general descriptions and/or technical characteristics of the performance of the products contained herein. This documentation is not intended as a substitute for and is not to be used for determining suitability or reliability of these products for specific user applications. It is the duty of any such user or integrator to perform the appropriate and complete risk analysis, evaluation and testing of the products with respect to the relevant specific application or use thereof. Neither Schneider Electric Industries SAS nor any of its affiliates or subsidiaries shall be responsible or liable for misuse of the information contained herein.

Offer Sustainability

Sustainable offer status	Green Premium product
REACH Regulation	REACH Declaration
REACH free of SVHC	Yes
EU RoHS Directive	Pro-active compliance (Product out of EU RoHS legal scope) EU RoHS Declaration
Toxic heavy metal free	Yes
Mercury free	Yes
China RoHS Regulation	China RoHS Declaration
RoHS exemption information	Yes
Environmental Disclosure	Product Environmental Profile
Circularity Profile	No need of specific recycling operations

Contractual warranty

Warranty	18 months
----------	-----------

Dimensions

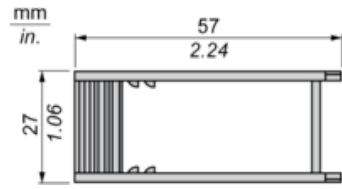

Mounting on All Sockets (1)

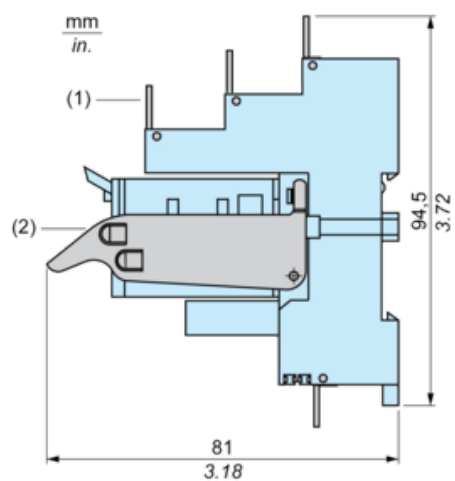

(1) Clip-in legends for all sockets except RXZE2M114

(2) Plastic clamp