

HDMI(M)(P1)
(MOLDING BLACK COLOR)

HDMI(M)(P2)
(MOLDING BLACK COLOR)

ITEM NO	COLOR	LENGTH
CDLHD-002	BLACK	2000±30mm
CDLHD-003	BLACK	3000±30mm
CDLHD-005	BLACK	5000±60mm
CDLHD-010	BLACK	10000±100mm
CDLHD-001	BLACK	1000±30mm

PIN ASSIGNMENT(1.4V)

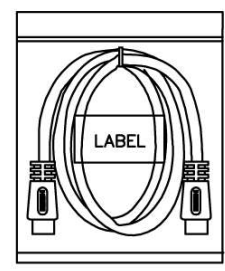
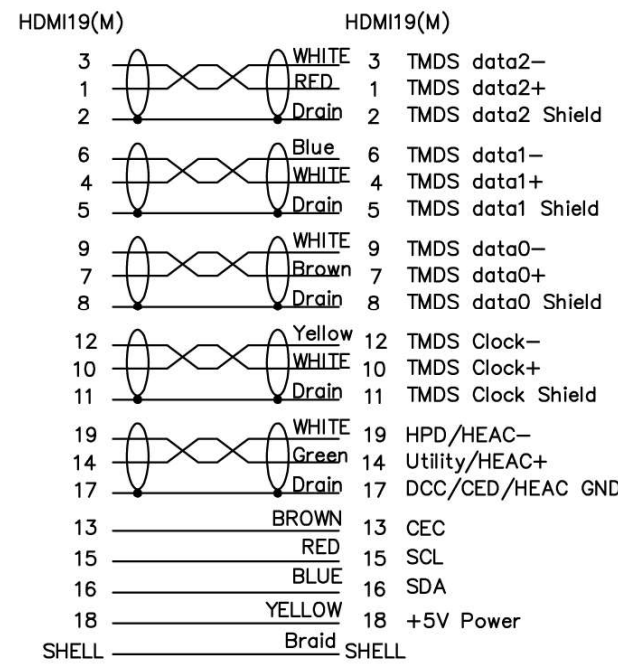

PACKING: OPP BAG+LABEL.

NOTE:

- CABLE: 28AWG,UL20276,AL-FOIL, (#28*1P+D)*5PCS+#30*4C+D,FLAT CABLE,BLACK COLOR, OD=3.4*13±0.2mm,PVC JACKET(single shielded)
- LENGTH:L.
- CONNECTORS: HDMI19P(M)*2PCS(BLACK INSULATOR)(GOLD PLATE SHELL).
- MOLD: MOLDING TYPE.
- CONTACTS:
- Test machine test condition.
A.100% OPEN,SHORT&INTERMITANCE TEST.
B.CONDUCTOR RESISTANCE: 3ohms MAX:
C.INSULATION RESISTANCE: 5M Min/,10ms:
- ALL MUST BE MEET ON ROHS COMPLIANT.



COMPANY			ITEM NO.	CDLHD-002	NO	P/N			SCALE	NON	
REVISION	DATE	DISCIPTION	DRAWN BY		SPEC				UNIT(mm)		
REV.A/6	2014.03.24	修正线材OD=3.4*13mm	DESIGNED BY						PAGE	1/1	
REV.A/4	2012.03.08	修正线材规格和接点 HDMI1.4REV	APPROVAL BY						SELL PERSON liable	SELL DATE	2013.04.25
REV.A/5	2012.08.22										