

Pneumatic sander - 1510

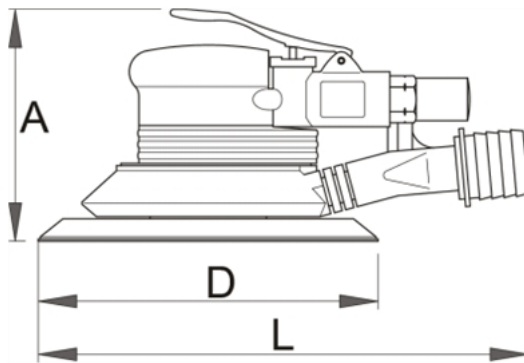
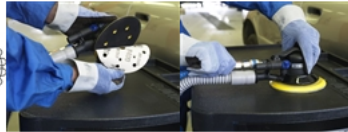
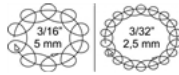

Description

- free speed 10000 revolution per minutes
- maximum air pressure : 6,2 Bar
- air consumption 212 l/min
- air inlet 1/4"
- velcro sander pad
-

Advantages:

- the ergonomic shape of the handle enables good grip and prevents gliding
- suitable for lefthanders as well as for right-handers
- silent and powerful drive
- handy on/off switch
- exhaustion of parts into a bag for a cleaner workplace
- flexible and robust pipe for cleaning dust
- it does not leave edges on the working platform
- better work conditions due to minimal vibrations
- extreme power based on its weight (1.2 kg)
-

Usage

- vehicle workshops
- preparation of different working platforms for further process
- ideal for grinding construction steel, metals and wood
- The basis of sander is VELCRO™ system which is: quick, simple and safe to mount and unmount various sander pads. This system is being used for various occasions - the best known example is training shoes with VELCRO™ fastening.

Technical Data

Barcode	Nº	L	A	D	Weight	Accessories	Tools	Other
617733	2.5	220	105	150	1600	1F	1	-
617713	5	220	105	150	1615	1F	1	-

Packaging data

Barcode	Nº	Retail tool packaging			Weight	Tools	Transport package		
		A	B	C			A1	B1	C1
617733 3	2.5	185	400	110	1670	1	-	-	-
617713 3	5	185	400	110	1685	1	-	-	-