

**Circuits from the Lab®**  
Reference Designs

*Circuits from the Lab® reference designs are engineered and tested for quick and easy system integration to help solve today's analog, mixed-signal, and RF design challenges. For more information and/or support, visit [www.analog.com/CN0371](http://www.analog.com/CN0371).*

### Devices Connected/Referenced

ADA2200	Synchronous Demodulator and Configurable Analog Filter
AD7192	4.8 kHz, Ultralow Noise, 24-Bit Sigma-Delta ADC with PGA
ADG794	Low Voltage, 300 MHz, Quad 2:1 Mux Analog HDTV Audio/Video Switch
ADP151	Ultralow Noise, 200 mA, CMOS Linear Regulator

## Low Power LVDT Signal Conditioner with Synchronous Demodulation

### EVALUATION AND DESIGN SUPPORT

#### Circuit Evaluation Boards

[CN-0371 Circuit Evaluation Board \(EVAL-CN0371-SDPZ\)](#)  
[System Demonstration Platform \(EVAL-SDP-CB1Z\)](#)

#### Design and Integration Files

[Schematics](#), [Layout Files](#), [Bill of Materials](#)

### CIRCUIT FUNCTION AND BENEFITS

The circuit shown in Figure 1 is a complete linear variable differential transformer (LVDT) signal conditioning circuit that can accurately measure linear position or linear displacement from a mechanical reference. Synchronous demodulation in the analog domain is used to extract the position information and provides immunity to external noise. A 24-bit,  $\Sigma$ - $\Delta$  analog-to-digital converter (ADC) digitizes the position output for high accuracy.

LVDTs utilize electromagnetic coupling between the movable core and the coil assembly. This contactless (and hence frictionless) operation is a primary reason for why they are widely used in aerospace, process controls, robotics, nuclear, chemical plants, hydraulics, power turbines, and other applications where operating environments can be hostile and long life and high reliability are required.

The entire circuit, including the LVDT excitation signal, consumes only 10 mW of power. The circuit excitation frequency and output data rates are SPI programmable. The system has a programmable bandwidth vs. dynamic range trade-off. It supports bandwidths of over 1 kHz, and at a bandwidth of 20 Hz, the circuit has a dynamic range of 100 dB, making it ideal for precision industrial position and gauging applications.

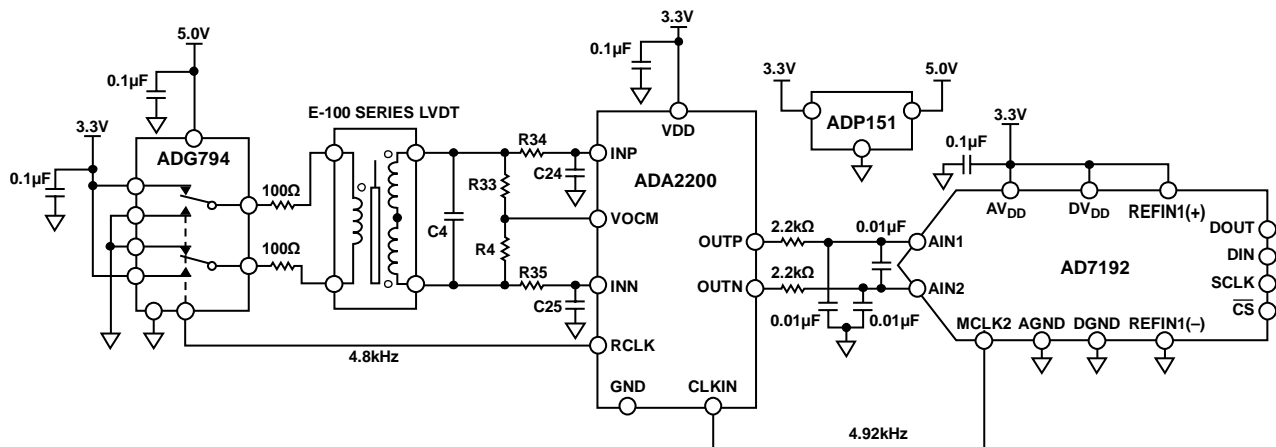

Figure 1. LVDT Signal Conditioning Circuit (Simplified Schematic: All Connections and Decoupling Not Shown)

#### Rev. 0

Circuits from the Lab® reference designs from Analog Devices have been designed and built by Analog Devices engineers. Standard engineering practices have been employed in the design and construction of each circuit, and their function and performance have been tested and verified in a lab environment at room temperature. However, you are solely responsible for testing the circuit and determining its suitability and applicability for your use and application. Accordingly, in no event shall Analog Devices be liable for direct, indirect, special, incidental, consequential or punitive damages due to any cause whatsoever connected to the use of any Circuits from the Lab circuits. (Continued on last page)

## CIRCUIT DESCRIPTION

The [ADA2200](#) synchronous demodulator extracts position information by filtering the LVDT secondary signal before demodulating the signal to a low frequency output voltage that is proportional to the LVDT core displacement. The [ADA2200](#) drives the [AD7192](#) 24-bit  $\Sigma$ - $\Delta$  ADC, which digitizes and filters the output. The [ADA2200](#) generates the synchronous LVDT excitation signal, and the [ADG794](#) switch converts the CMOS level excitation signal into a precision 3.3 V square wave to drive LVDT primary winding.

The LVDT is an absolute displacement transducer that converts a linear displacement into a proportional electrical signal. An LVDT is a specially wound transformer with a moveable core that is affixed to the position to be measured. An excitation signal is applied to the primary windings. As the core moves, the voltage on the secondary windings changes proportionally, and from this voltage, position is calculated.

There are many types of LVDTs and different ways of extracting position from them. The Figure 1 circuit uses the LVDT in 4-wire mode. The two LVDT secondary outputs are connected such that the voltages oppose each other, performing a subtraction. When the LVDT core is in its null position, the voltages on each of the two secondaries are equal, and the voltage difference across the two windings is zero. As the core moves from the null position, the difference voltage across the secondary windings increases. The phase of the LVDT output voltage changes based on direction.

The master clock for this circuit is generated by the [AD7192](#) ADC. The [ADA2200](#) accepts the master clock and generates all of its internal clocks, including the reference clock used as the LVDT excitation signal. The clock dividers on the [ADA2200](#) are configured to provide an excitation signal of 4.8 kHz. The [ADG794](#) converts the excitation signal to a precision  $\pm 3.3$  V square wave from the ADC supply voltage. The 3.3 V supply is also used as the ADC reference voltage; therefore, the ratiometric relationship between the excitation signal and ADC reference voltage improves the noise and stability performance of the circuit. The 3.3 V for the system is supplied by an [ADP151](#) low dropout regulator driven from a 5 V supply.

The coupling circuit between the LVDT secondary windings and the [ADA2200](#) input is used to band limit the signal and to adjust the relative phase between the RCLK and [ADA2200](#) input. The circuit is configured to maximize the quadrature (Phase =  $90^\circ$ ) response and to minimize the in-phase (Phase =  $0^\circ$ ) response. This enables the position to be determined by only measuring the quadrature output and makes the [ADA2200](#) output voltage less sensitive to phase variations in the circuit. The main sources of phase variation come from temperature changes in the LVDT that cause its effective series resistance and inductance to change.

The antialiasing filter at the [ADA2200](#) output maintains the signal bandwidth supported by the ADC. The output bandwidth of the [AD7192](#) internal digital filter is approximately 0.27 times

the output data rate. To maintain the output bandwidth at the maximum output data rate of 4.8 kHz, the output antialiasing filter  $-3$  dB corner frequency is set to approximately 2 kHz. For systems requiring lower output data rates, the antialiasing filter corner frequency can be reduced accordingly.

### Integrated Synchronous Demodulator

The [ADA2200](#) integrated synchronous demodulator forms the core of the circuit. It uses a unique charge sharing technology to perform discrete time signal processing in the analog domain. The signal path of the [ADA2200](#) is completely differential. It consists of a high impedance input buffer followed by a fixed low-pass filter (FIR decimation filter), a programmable IIR filter, a demodulator, and a differential output buffer. It has an input and output common-mode voltage equal of 1.65 V ( $\frac{1}{2}$  of the 3.3 V supply voltage).

The [ADA2200](#) accepts the 4.92 MHz clock from the [AD7192](#) ADC and generates all of its internal clocking signals as well as the 4.8 kHz reference clock used as the LVDT excitation signal. The [ADA2200](#) has configurable clock dividers that can be programmed to support many different excitation frequencies.

### CMOS Switch

The [ADG794](#) CMOS switch was chosen for the low on resistance of the switches, fast switching times, break-before-make switching action, and low cost.

The [ADG794](#) converts the low voltage CMOS-level RCLK output of the [ADA2200](#) into a low impedance differential output square wave source, which drives the LVDT. To provide headroom for the switches to drive the positive 3.3 V signal, the [ADG794](#)  $V_{DD}$  input is supplied from the 5 V power supply.

### LVDT

The Figure 1 circuit supports a wide variety of LVDTs with minor modifications. The E-100 LVDT from Measurement Specialties, Inc., was used in 4-wire mode to demonstrate the main attributes of the circuit. The E-100 has a stroke range of  $\pm 2.54$  mm, an output sensitivity of 240 mV/V at the stroke ends, and a maximum linearity error of  $\pm 0.5\%$  of full-scale range. The operating frequency range is from 100 Hz to 10 kHz. See the E-Series LVDT data sheet for complete details.

### ADA2200 Input Coupling Network

The [ADA2200](#) input coupling network can be tuned for different LVDTs. The inductance of the LVDT secondary windings and the shunt capacitor (C4) form a tank circuit. The R4 and R33 resistors reduce the Q of the tank circuit, making the circuit less sensitive to changes in the LVDT winding inductance and resistance at the expense of increased power consumption. The pair of RC filters created by R34/C24 and R35/C25 reduces the signal bandwidth and provides additional degrees of freedom for adjusting the relative phase of the circuit. The maximum output from the [ADA2200](#) internal phase sensitive detector (PSD) occurs at relative phase shifts of  $0^\circ$  or  $180^\circ$ .

For the E-100 LVDT with a 4.8 kHz square wave excitation, the optimum phase for maximum output is achieved for the following component values:

- $R4 = R33 = 2.2 \text{ k}\Omega$
- $R34 = R35 = 1 \text{ k}\Omega$
- $C24 = C25 = 3300 \text{ pF}$
- $C4 = 0.01 \text{ }\mu\text{F}$

To tune the circuit, the phase can be measured by placing the LVDT core to produce a near full-scale output signal. Next, make in-phase (I) and quadrature (Q) output signal measurements. From these measurements, the relative phase is calculated as follows:

$$A = \sqrt{I^2 + Q^2}$$

$$\theta_{REL} = \cos^{-1}\left[\frac{Q}{A}\right]$$

Adjusting the network components until the absolute value of  $\theta_{REL}$  is less than approximately  $\pm 3^\circ$  improves the circuit sensitivity to variation in the LVDT electrical parameters.

### ADC Selection and Synchronization

The AD7192  $\Sigma$ - $\Delta$  ADC was chosen because it supports a configurable output data rate and has different digital filter output options, thereby allowing trade-offs between bandwidth and noise. The master clock output feature makes it easy to lock the frequency of the ADC sample clock to the ADA2200 output signal. This is required to optimize the performance of the digital filters. The desired value for determining the position from the LVDT signal is the average value over one excitation clock period. Therefore, when the AD7192 output data rate is set to 4.8 kHz, exactly one excitation clock period, the desired average is obtained. If the excitation clock period and ADC sampling frequency are not locked, an error is induced in the recovered position measurements. Dividing the output data rate is effectively taking the average over multiple excitation clock periods.

The digital filter performance can be analyzed in the frequency domain as well. Even when the LVDT core position is fixed, the ADA2200 output signal contains energy at multiples of the excitation signal frequency. These frequency components are spurious error sources. The AD7192 has a  $\text{sinc}^3$  or  $\text{sinc}^4$  transfer function with transfer function zeros at multiples of the output data rate. The output spurs are rejected by setting the output data rate of the ADC to the excitation signal frequency (or submultiples of the excitation frequency). If the excitation clock period and ADC sampling frequency are not locked, the spurs will not fall in the nulls of the transfer function.

A complete set of documentation for the circuit including schematics, layouts, and bill of materials can be found at [www.analog.com/CN0371-DesignSupport](http://www.analog.com/CN0371-DesignSupport).

### User Software for Performance Analysis

The circuit is supported with a graphical user interface that facilitates configuring the devices on the board and evaluating the circuit performance. Tabs are available for performing circuit calibration and device configuration, as well as for displaying noise performance, linearity performance, and real time position measurements. For a complete description of the software package, see the [CN-0371 Software User Guide](#).

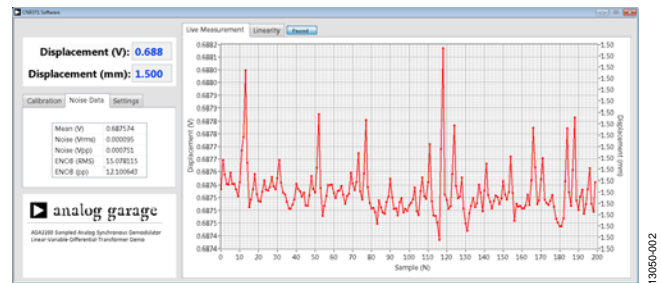

Figure 2. User Software Screen Capture

### Noise Analysis

The output noise of the circuit is a function of the ADC output data rate. Table 1 shows the effective number of bits (ENOB) in the digitized data vs. the ADC sample rate, assuming a 2.5 V full-scale output voltage. The noise performance of the circuit is independent of the LVDT core position.

Table 1. Noise Performance vs. Bandwidth

ADC Data Rate (SPS)	Output Bandwidth (Hz)	ENOBs (RMS)	ENOBs (P-P)
4800	1300	14.0	11.5
1200	325	14.9	12.4
300	80	15.8	13.3
75	20	16.2	13.6

If the ADA2200 output noise were frequency independent, the expected effective number of bits would increase by one bit for every four-fold decrease in the output data rate. The diminishing increase in ENOBs at the lower output data rates is caused by the  $1/f$  noise of the output driver that begins to dominate the noise floor at the lower output data rates.

### Linearity Test Results

The linearity results were measured by first performing a two-point calibration at core displacements of  $\pm 2.0 \text{ mm}$ . From these two measurements, the slope and offset were determined to establish an expected straight line fit. Next, measurements were taken at core displacements across the full-scale range of  $\pm 2.5 \text{ mm}$ . The measured data was subtracted from the expected straight line fit data to determine the linearity error.

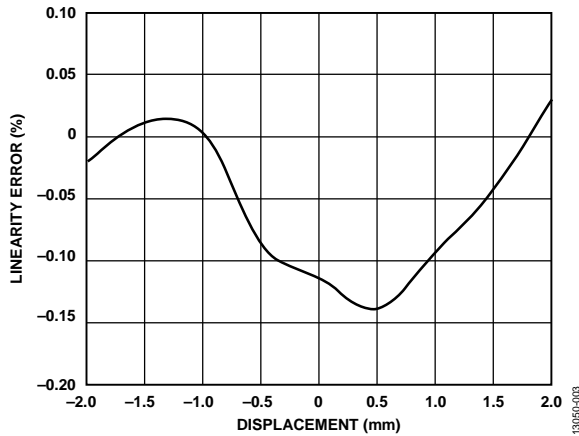

Figure 3. Position Linearity Error vs. LVDT Core Displacement

The measured data shows that the circuit performance is better than the linearity specified in the E-Series LVDT data sheet.

**Synchronous Operation of Multiple LVDTs**

In many applications, multiple LVDTs are used in close proximity. If the LVDTs operate at similar carrier frequencies, stray magnetic coupling can cause generation of beat notes. The resulting beat notes can interfere with the accuracy of measurements made under these conditions. To avoid this situation, all LVDTs must be synchronized.

Multiple ADA2200 devices can be synchronized by bringing the devices out of reset simultaneously. The ADA2200 leaves reset mode on the first rising edge of CLKIN after the RST pin is deasserted. Therefore, driving all of the ADA2200 CLKIN pins from a single source and all of the RESETB lines from a single source is sufficient to ensure the devices operate synchronously. Avoid deasserting RESETB near the rising edge of CLKIN to prevent the device resets from occurring on different clock edges. The RCLK outputs of the ADA2200 devices can be monitored to ensure that the ADA2200 devices are properly synchronized.

**COMMON VARIATIONS**

In some systems, it may be desirable to use a SAR ADC instead of a Σ-Δ converter. In these cases, the ADC conversion clock must be synchronized with the ADA2200 update rate. As described previously, the ADA2200 output will contain spurs at multiples of the excitation frequency. These spurs can be rejected with a moving average filter or by cascading multiple moving average filters. Moving average filters are easy to implement and exhibit excellent time-domain characteristics. To completely reject the spurs, the moving average sample size must be an integer multiple of 8 samples.

Figure 4 shows the ADA2200 connected to the AD7091R-2, an ultralow power, dual channel, 12-bit SAR ADC. A dual channel ADC is used so that the OUTP and OUTN outputs of the ADA2200 can be sampled sequentially. Because the ADA2200 outputs are discrete time samples, differential measurements can be made by performing the difference operation,  $V_{OUTP} - V_{OUTN}$ , on the two sequential output samples.

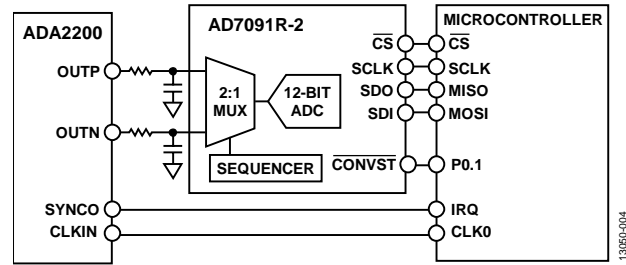

Figure 4. Differential Sampling with Dual Channel SAR ADC

The SYNCO signal goes active each ADA2200 output sample period. SYNCO can be used to interrupt the microcontroller to take a pair of ADC samples (to sample OUTP and OUTN). In the case demonstrated, the sample period is at 8 times the excitation clock frequency or 38.4 kHz; therefore, the ADC samples at a rate of 76.8 kSPS.

**CIRCUIT EVALUATION AND TEST**

The CN-0371 circuit uses the EVAL-CN0371-SDPZ circuit board and the EVAL-SDP-CB1Z SDP-B controller board. The two boards have 120-pin mating connectors, allowing quick setup and evaluation of the performance of the circuit. The circuit board contains the circuit to be evaluated, and the SDP-B board is used with the CN-0371 Evaluation Software to capture the data from the circuit board.

**Equipment Needed**

The following equipment is needed:

- A PC with a USB port and Windows® XP (32-bit), Windows Vista®, or Windows 7
- The EVAL-CN0371-SDPZ circuit board
- The EVAL-SDP-CB1Z SDP-B controller board
- The CN-0371 Evaluation Software
- Measurement Specialties, Inc., E-100 Economy Series LVDT (EVAL-CFTL-LVDT)

**Getting Started**

Download the CN0371.zip file and run the setup.exe file. By default, the program is installed in the Analog Devices directory. The program name is CN0371.

**Functional Block Diagram**

See Figure 5 for the circuit block diagram. For the complete circuit schematic, see the EVAL-CN0371-SDPZ-Schematic.pdf file, which can be found in the CN-0371 Design Support Package. The 5 V supply for the circuit board is supplied by the USB bus via the SDP-B board 120-pin connector.

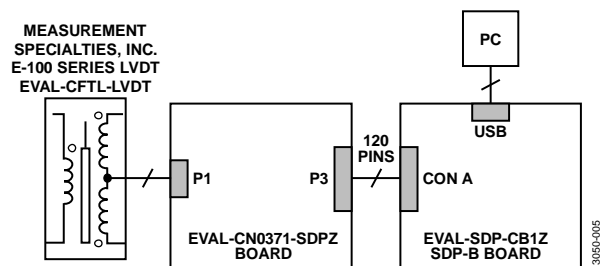

Figure 5. Test Setup Block Diagram



### Setup

Connect the 120-pin connector on the [EVAL-CN0371-SDPZ](#) circuit board to the CON A connector on the [EVAL-SDP-CB1Z](#) SDP-B board. Use nylon hardware to firmly secure the two boards, using the holes provided at the ends of the 120-pin connectors.

### Test

Launch the evaluation software and connect the USB cable from the PC to the mini-USB connector on the SDP-B board.

When USB communications are established, the SDP-B board can send, receive, and capture data from the circuit board.

Figure 6 shows a photo of the circuit board connected to the SDP-B board. Information regarding the SDP-B board can be found in the [UG-277 User Guide](#).

Information and details regarding test setup, calibration, and how to use the evaluation software for data capture can be found in the [CN-0371 Software User Guide](#).

### Connectivity for Prototype Development

The [EVAL-CN0371-SDPZ](#) circuit board is designed for use with the [EVAL-SDP-CB1Z](#) SDP-B board; however, any microprocessor can be used to interface to the SPI interface of the [AD7192](#). For another controller to be used with the [EVAL-CN0371-SDPZ](#) circuit board, software must be developed by a third party.

There are existing interposer boards that can be used to interface to the Altera and Xilinx field programmable gate arrays (FPGAs). The BeMicro SDK board from Altera can be used with the BeMicro SDK/SDP interposer using nios drivers. Any Xilinx evaluation board that features an FMC connector can be used with the FMC-SDP interposer board.

The [EVAL-CN0371-SDPZ](#) is also compatible with the Digilent, Imod interface specification.

Figure 6 shows a photo of the system test setup. Complete documentation including schematics, layouts, Gerber files, and bill of materials can be found in the [CN0371 Design Support Package](#) at [www.analog.com/CN0371-DesignSupport](http://www.analog.com/CN0371-DesignSupport).

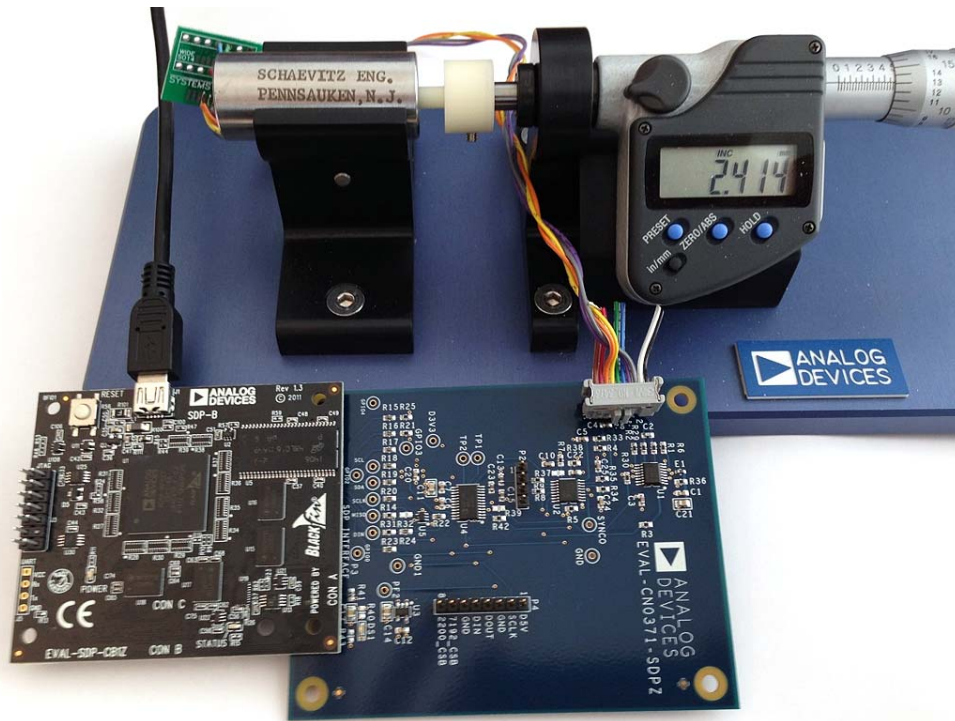

Figure 6. [EVAL-CN0371-SDPZ](#) Circuit Board Connected to [EVAL-SDP-CB1Z](#) SDP-B Board and LVDT with Core Connected to Precision Gauge Head

13050-0001

**LEARN MORE**

CN-0371 Design Support Package:

[www.analog.com/CN0371-DesignSupport](http://www.analog.com/CN0371-DesignSupport)

[SDP-B User Guide](#)

*E Series Economy Series LVDT Datasheet*. Measurement Specialties, Inc.

*The LVDT: Construction and Principle of Operation*. Technical Paper. Measurement Specialties, Inc.

*Subminiature LVDTs Provide Accurate Flight Control Surface Position Feedback on UAVs*. Application Note. Measurement Specialties, Inc.

*LVDT Basics*. Technical Bulletin. Macro Sensors.

**Data Sheets and Evaluation Boards**

[CN-0371 Circuit Evaluation Board \(EVAL-CN0371-SDPZ\)](#)

[System Demonstration Platform \(EVAL-SDP-CB1Z\)](#)

[ADA2200 Data Sheet](#)

[AD7192 Data Sheet](#)

[ADG794 Data Sheet](#)

[ADP151 Data Sheet](#)

**REVISION HISTORY**

3/15—Revision 0: Initial Version

(Continued from first page) Circuits from the Lab reference designs are intended only for use with Analog Devices products and are the intellectual property of Analog Devices or its licensors. While you may use the Circuits from the Lab reference designs in the design of your product, no other license is granted by implication or otherwise under any patents or other intellectual property by application or use of the Circuits from the Lab reference designs. Information furnished by Analog Devices is believed to be accurate and reliable. However, Circuits from the Lab reference designs are supplied "as is" and without warranties of any kind, express, implied, or statutory including, but not limited to, any implied warranty of merchantability, noninfringement or fitness for a particular purpose and no responsibility is assumed by Analog Devices for their use, nor for any infringements of patents or other rights of third parties that may result from their use. Analog Devices reserves the right to change any Circuits from the Lab reference designs at any time without notice but is under no obligation to do so.

©2015 Analog Devices, Inc. All rights reserved. Trademarks and registered trademarks are the property of their respective owners.  
CN13050-0-3/15(0)

