

FEATURES

- Female banana plug
- Silver-plated brass contact
- Keeps your cables and equipment safe
- Voltage rating: 50V
- Current rating: 10A
- Polypropylene insulation material to ensure a strong and durable plug
- Operating Temperature range of -20 to +147

RS PRO White Female Banana Connectors

RS Stock No.: 2121229



RS Professionally Approved Products bring to you professional quality parts across all product categories. Our product range has been tested by engineers and provides a comparable quality to the leading brands without paying a premium price.

Product Description

Looking to make your own test leads, then RS PRO has the perfect addition in the female banana connector. This socket connector is the ideal solution for making test leads to your specification. Upon inspection, the socket offers high-grade plastic insulation with a centre contact made from silver-plated brass with a transfer termination method. It is suitable for panels up to 13.5 mm thickness and is designed to accommodate standard 4 mm insulated or non-insulated banana plugs.

General Specifications

Insulating shell	Polypropylene
Socket	Brass, silver plated
Nut	Brass, Nickel Plated

Electrical Specifications

AMPS	10A
Contact Resistance	10 mΩ
Nominal Working Voltage	250 VOLTS R.M.S
Temperature Range	+147°C to -20°C
Recommended Temperature	10A @ 55°C
Rated Current	10 A
Rated Voltage	50 V

Mechanical

Recommended Torque	0.4Nm MAX
Recommended Panel Thickness	13.5mm MAX

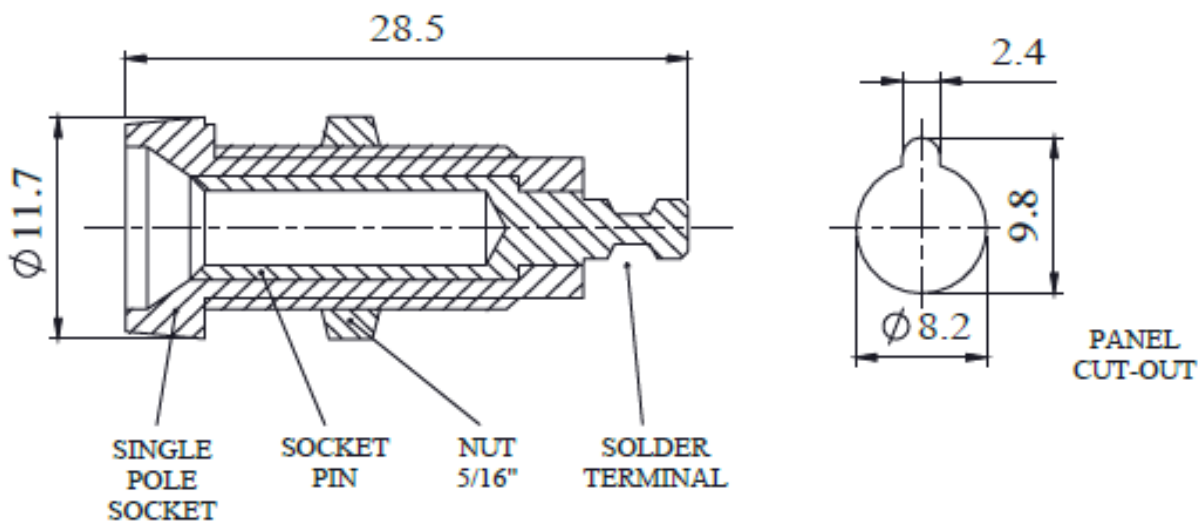

Note:UNLESS OTHERWISE SPECIFIED DIMENSIONS ARE IN MILLIMETRES

LINEAR & RADIAL TOLERANCE: NO DECIMAL PLACES 0.2mm

1 DECIMAL PLACE 0.1mm 2 DECIMAL PLACES 0.05mm

ANGULAR TOLERANCE: 1

THE FINISHED PRODUCT SHOULD BE CLEAN AND FREE FROM ALL LIQUIDS AND DEBRIS. SURFACES SHOULD BE OF UNIFORM APPEARANCE FREE FROM SHARP EDGES, BURRS AND CORROSION