



# DC Injection-brake modules



## Instruction Leaflet

Size 0.25...2.2 kW  
1.1...5.5 kW

RS stock no. 209-6384  
209-6407

Figure 1 Recommended connection for use with induction motors with DOL starting

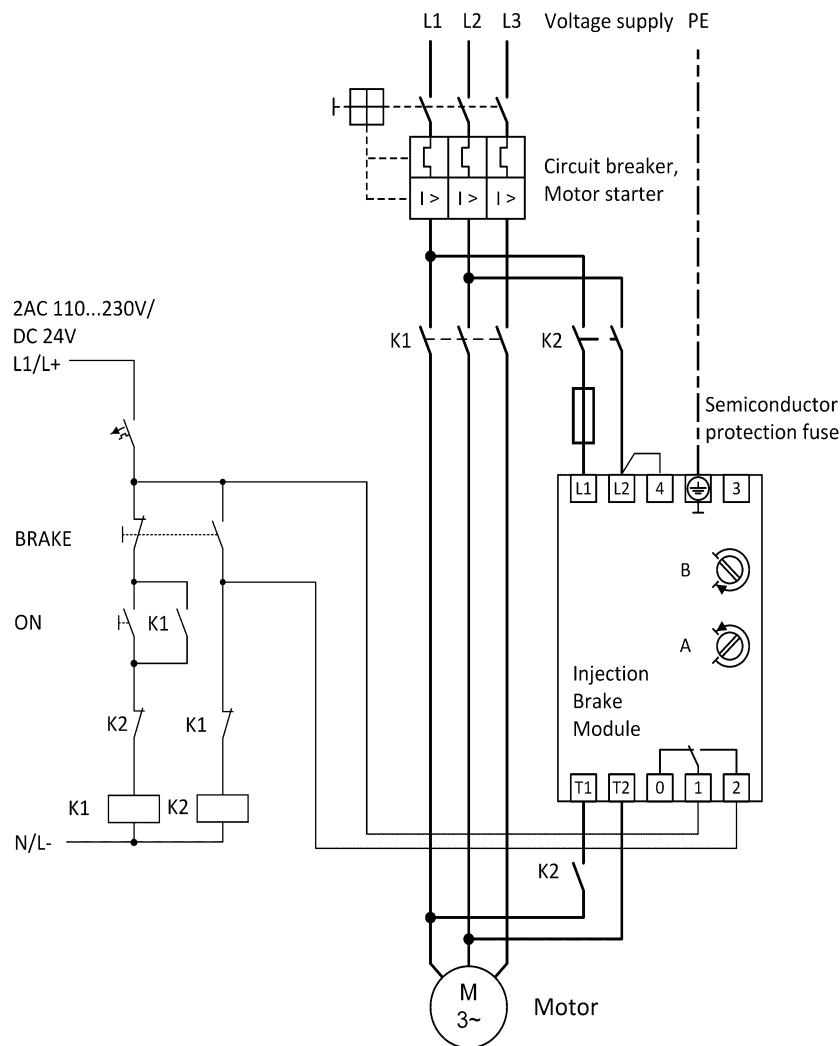

### General

RS DC Injection-Brake Modules provide a method of rapidly stopping production and machine tool processes smoothly. Designed to replace mechanical brakes these modules will brake three-phase induction motors from 0.25 up to 5.5 kW in 2 module sizes. These compact DIN-rail mounted modules have the advantages of separate braking torque and braking time-out adjustment; fast initiation of function, no maintenance requirements and simple connection.

### Adjustment procedure

1. Set potentiometer A (Braking time-out) and potentiometer B (Braking torque), both fully counter clockwise.
2. Increase potentiometer B in a clockwise direction until the required braking performance is obtained by starting and stopping the motor.
3. Adjust potentiometer A until Braking Relay (MB) opens just after the motor has stopped (braking complete).

**Note** The above should be carried out for the maximum operational load that the motor is likely to experience with the motor at operating temperature.

## Adjustment ranges

Designation, Meaning	Scaling	Explanation
B - Braking torque		Rated braking torque
A - Braking time-out		Electrical braking time

## Control input

Signal	Terminals		Remarks
	L2-4		
BB - Command "Brake"	Inhibited	Enable	Caution, supply voltage

## Control output

Signal	Terminals		Remarks
	0-1	1-2	
MB - Control output "Braking"	open	closed	Braking
	closed	open	End of braking, no supply

Isolated relay contact with rating AC 250 V, 2 A; 250 VA

- Suggestion for initial setting (initial factory setting)  
The above values are approximate values only

## Technical specifications

Electrical	RS Stock no. 209-6384	RS Stock no. 209-6407
Rated Voltage	2AC 400 V +10-15 %	
Rated Frequency	50/60 Hz ±2 %	
Rated Motor Power	2.2 kW	5.5 kW
Min. Motor Power	0.25 kW	1.1 kW
Max. braking current	11 A	30 A
Output voltage	DC 0...150 V	
Max braking duty* at max. braking current		
- side-by-side	10 %	3 %
- intermediate spacing 10 mm	15 %	5 %
EN 60947-4-2:		
- Utilization category	11 A: AC-53a: 1-10: 10-36	30 A: AC-53a: 1-10: 3-11
- Form designation	1 (any starting method with controlled braking)	1 (any starting method with controlled braking)
Overvoltage category to EN 60664-1/ Rated insulation voltage to PE	III / AC 230 V only for use with TT/TN supplies with earthed neutral	
Terminals	1.0...2.5 mm <sup>2</sup> multistrand with end ferrules	
D style semiconductor protection fuse type gR, recommended RS Stock No. (for prospective short-circuit current up to 50 kA)	20 A 422-551	35 A 421-520

\* Braking duty refers to the percentage of operating time the RS DC Injection-Brake Module is performing braking.

<b>Environment</b>	Permissible temperatures:	Operation: 0... +40 °C Storage: -25... +55 °C Transport -25... +70 °C		
	Climatic conditions:	Class 3K3 to EN 60721-3-3 (5...85 % relative humidity). The cooling air must have little dust and be non-corrosive and non-flammable.		
	Pollution:	Degree 2 to EN 60664-1: Dry non conducting dust or particles, infrequent light condensation when switched off permissible		
	Altitude:	max. 2000 m NN above sea level, ≥ 1000 m: 1,5 % / 100 m power derating		
<b>Safety</b>	Relevant standards:	EN 60947-4-2, EN 50178		
	Protective class:	I to EN 61140 i.e. basic insulation with PE connection (protective earth). The user is responsible for the PE connection.		
	IP Protection:	IP20 to EN 60529 Finger protection		
	Signal and control terminals:	The control circuit is protected by basic insulation from the supply voltage. Any components connected to the control circuit (e.g. external push buttons) must be protected against direct contact by additional insulation.		
<b>Installation</b>	Weight (approx.)	400 g	450 g	
	Dimensions:	Height	75 mm	75 mm
		Width	45 mm	45 mm
Depth		120 mm	120 mm	
<b>General</b>	Technical data subject to change without notice			



## EC directives and regulations

### 'CE' marking

The 'CE' marking of the RS DC Injection-Brake Modules is at the date at which this Product Manual is issued valid for the EU DIRECTIVES

- 2014/30/EU EMC DIRECTIVE
- 2014/35/EU LOW-VOLTAGE DIRECTIVE

Manufacturers of apparatus and machines sold as functional units are fully responsible for issuing a Declaration of Conformity and applying the 'CE' mark.

### EMC directive

RS DC Injection-Brake Modules are components with a function which is determined by the construction and layout of the complete installation. It is the responsibility of user to ensure that the EMC DIRECTIVE is adhered to. The following standards are particularly relevant:

Product Standard for AC semiconductor motor starters (also valid for braking equipment):	EN 60947-4-2
RF Interference:	EN 55011
Immunity:	EN 61000-4-2/-3/-4/-5

### Declaration of Conformity:

A Declaration of Conformity declaring conformance of these RS DC Injection-Brake Modules with the EMC DIRECTIVE based on the Product Standard EN60947-4-2 which references the above standards for RF Interference and Immunity is available on request. Particular reference should be made to the instructions for planning the installation concerning interference suppression and immunity.

During continuous operation Interference Limit B for use in residential, commercial and light industry supplied directly from public electricity supply (including public buildings, banks, hospitals etc.) is adhered to.

### Other important information:

The user should be conversant with the following issues:

- EMC 'CE' Responsibility, and in particular the CEMEP recommendations for application of the EMC DIRECTIVE to electronic power drive equipment
- Limit values of permissible EMC interference when used in:
  - Residential areas (Class B)
  - Industrial areas with own transformer station (Class A)
- Responsibility of manufacturers of apparatus and machines sold as complete functional units

### Low-voltage directive

It is the responsibility of the user to ensure that the complete installation adheres to the LOW-VOLTAGE DIRECTIVE. The following standards should be considered as is appropriate:

- Product Standard for AC semiconductor motor starters (also valid for braking equipment): EN 60947-4-2
- Installation with power electronic equipment: EN 50178
- Installation regulations in electrical enclosures: EN 60439-1
- Electrical equipment of machines: EN 60204-1

### Declaration of Conformity:

A Declaration of Conformity declaring conformance of these injection brake modules with the LOW-VOLTAGE DIRECTIVE based on the product standard EN 60947-4-2 and EN 50178 is available on request. Particular reference should be made to the Technical Data and to the instructions for planning the installation.

### Machinery directive

RS DC Injection-Brake Modules are components to be incorporated into machinery and may not be operated alone. Pay particular reference to the following standard:

- Electrical equipment of machines EN 60204-1

### Disposal

During transport, our products are protected by packaging as far as necessary. The packaging consists entirely of environmentally compatible material that should be taken for central disposal as valuable secondary raw materials.

Contact the relevant Local Authority department to find out about disposal, including disposal of old appliances.

## Table for fault finding

Fault	Possible cause	Cure
1. Not enough braking torque	<ul style="list-style-type: none"> <li>• Adjustments not suitable</li> <li>• Motor not suitable for d.c. injection braking</li> </ul>	<ul style="list-style-type: none"> <li>- Increase braking torque by turning potentiometer B cw</li> <li>- Check braking time-out. Increase time by turning potentiometer A ccw if necessary.</li> <li>- Change motor, the next frame size may help</li> </ul>
2. Frequent failures of brake module with damaged power semiconductors	<ul style="list-style-type: none"> <li>• Short circuit due to connection fault</li> </ul>	<ul style="list-style-type: none"> <li>- Verify correct function of interlocks for motor and braking contactors. Compare with recommended connections. Caution with software interlocks.</li> </ul>
3. Controller suspected to be faulty (e.g. following a short circuit)	<ul style="list-style-type: none"> <li>• Power semiconductors damaged. Check the terminals do not have a short circuit using a <math>\Omega</math>-meter.</li> </ul>	<ul style="list-style-type: none"> <li>- Return controller to supplier</li> </ul>
4. Everything tried without success		<ul style="list-style-type: none"> <li>- Send circuit diagram of application and potentiometer settings by fax to your supplier</li> </ul>



Figure 5 **Recommended connection as combined soft-start and injection brake using RS Soft-Start Modules 212-8683 and 212-8699**

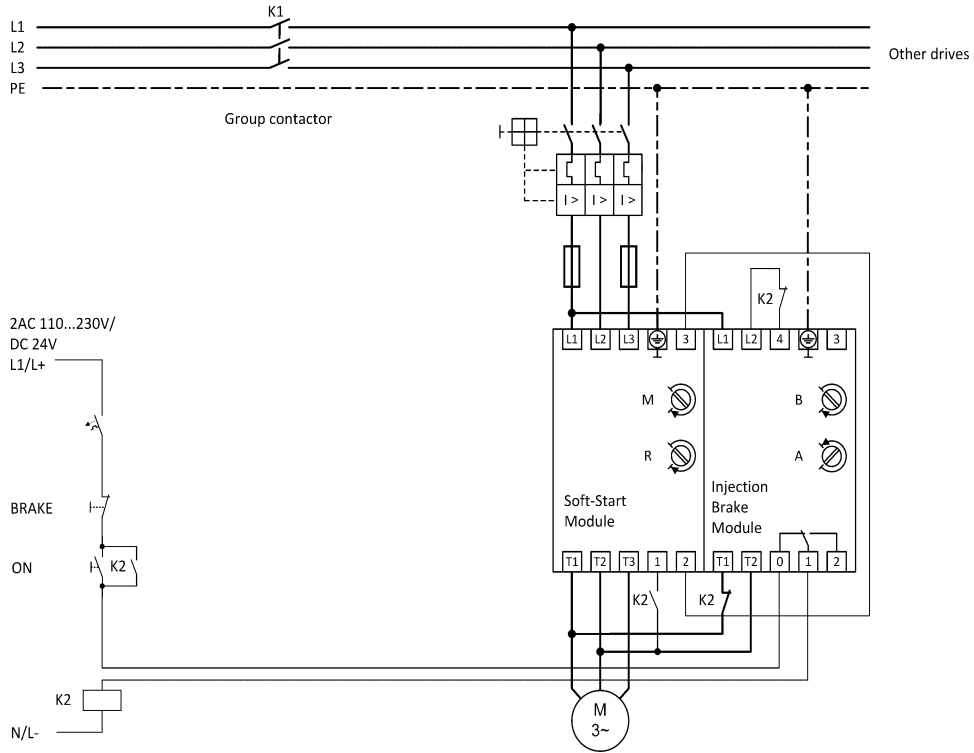
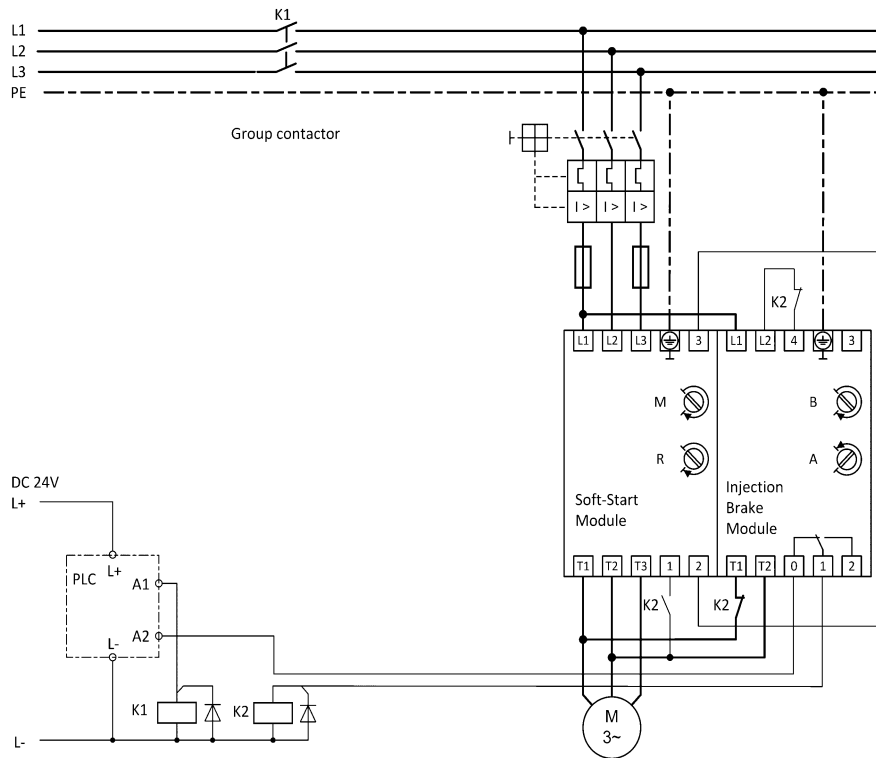

Figure 6 **Alternative connection with PLC-control as combined soft-start and injection brake using RS Soft-Start Modules 212-8683 and 212-8699**



The information provided in RS instruction leaflet is believed to be accurate and reliable, however RS Components assumes no responsibility for inaccuracies or omissions, or for the use of this information, and all use of such information shall be entirely at the user's own risk. No responsibility is assumed by RS Components for any infringements of patents or other rights of third parties which may result from its use. Specifications shown in RS Components instruction leaflets are subject to change without notice.

RS Components Ltd., Birchington Road, Corby, NN179RS, United Kingdom  
 RS Components GmbH, Mainzer Landstraße 180, 60327 Frankfurt/Main, Germany