



Main

Range of product	Preventa Safety automation
Product or component type	Safe speed monitoring module
Device short name	XPSMCM
Electrical connection	Screw terminal
[Us] rated supply voltage	24 V (- 20...20 %) DC
Discrete input voltage	24 V DC
Function of module	Speed monitoring

Complementary

Power consumption in W	<= 3 W
Power dissipation in W	3 W
Integrated connection type	Backplane expansion bus
Safety level	SILCL 3 conforming to IEC 62061 Can reach category 4 conforming to EN/ISO 13849-1 Can reach PL = e conforming to EN/ISO 13849-1 Type 4 conforming to EN/IEC 61496-1
Quality labels	CE
Number of terminal blocks	4
Local signalling	1 LED green with PWR marking for power ON 1 LED green with RUN marking for RUN (status) 1 LED red with E IN marking for internal error 1 LED red with E EX marking for external error 2 LEDs orange with ADDR marking for node address 1 LED yellow with ENC marking for encoder connection status 2 LEDs yellow with PROX marking for proximity sensors connection status 2 LEDs yellow with SH marking for speed monitoring status
Connections - terminals	2-wire captive screw clamp terminals, removable terminal block 1-wire captive screw clamp terminals, removable terminal block
Input frequency	<= 5 kHz for sensor <= 500 kHz for encoder SinCos
Sensor type	Inductive proximity sensor

Electrical connection	1 connector RJ45 conforming to EIA/TIA-568-A
Cable cross section	(0.2...1.5 mm ² - AWG 24...AWG 16) flexible cable without cable end (0.2...2.5 mm ² - AWG 24...AWG 14) flexible cable without cable end (0.25...1 mm ² - AWG 23...AWG 18) flexible cable with cable end, without bezel (0.25...2.5 mm ² - AWG 23...AWG 14) flexible cable with cable end, with bezel (0.5...1.5 mm ² - AWG 20...AWG 16) flexible cable with cable end, with double bezel (0.2...1 mm ² - AWG 24...AWG 18) solid cable without cable end (0.2...2.5 mm ² - AWG 24...AWG 14) solid cable without cable end (0.25...2.5 mm ² - AWG 23...AWG 14) flexible cable with cable end, without bezel
Mounting support	Omega 35 mm DIN rail conforming to EN 50022
Depth	22.5 mm
Height	99 mm
Width	114.5 mm
Product weight	0.28 kg

Environment

Standards	EN/IEC 61496-1 EN/IEC 61508 EN/IEC 61800-5-1 EN/ISO 13849-1 IEC 62061
Product certifications	CULus TÜV RCM
IP degree of protection	IP20 for enclosure
Ambient air temperature for operation	-10...55 °C
Ambient air temperature for storage	-20...85 °C
Relative humidity	10...95 %
Pollution degree	2
[Uimp] rated impulse withstand voltage	4 kV conforming to EN/IEC 61800-5
Insulation	250 V AC between power supply and housing conforming to EN/IEC 61800-5-1
Overvoltage category	II
Electromagnetic compatibility	Electrostatic discharge immunity test - test level 6 kV, on contact conforming to EN/IEC 61000-4-2 Electrostatic discharge immunity test - test level 20 kV, on air conforming to EN/IEC 61000-4-2 Susceptibility to electromagnetic fields - test level 10 V/m, 80...1000 MHz conforming to EN/IEC 61000-4-3 Susceptibility to electromagnetic fields - test level 30 V/m, 1.4 GHz...2 GHz conforming to EN/IEC 61000-4-3
Vibration resistance	+/-0.35 mm (f = 10...55 Hz) conforming to EN/IEC 61496-1
Shock resistance	10 gn (duration = 16 ms) shocks : 1000 shocks on each axis EN/IEC 61496-1
Service life	20 yr

Offer Sustainability

Sustainable offer status	Green Premium product
RoHS (date code: YYWW)	Compliant - since 1450 - Schneider Electric declaration of conformity Schneider Electric declaration of conformity
REACH	Reference not containing SVHC above the threshold Reference not containing SVHC above the threshold
Product environmental profile	Available
Product end of life instructions	Available

Dimensions

Screw Terminal

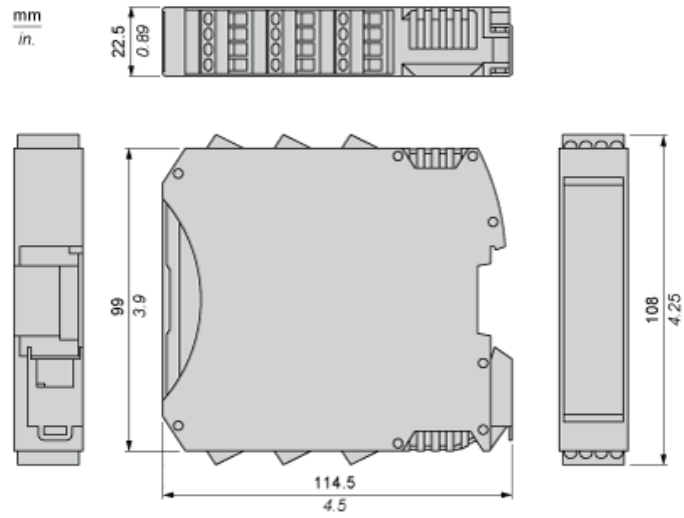

Mounting Safety Controller CPU with Module(s)

Mount BackPlane Connector on Rail

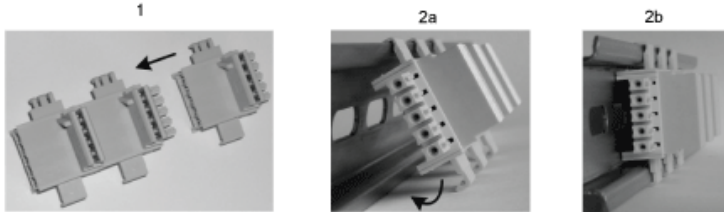

- 1 : Connect as much Backplane Connector as module to be install.
- 2 : Fix the connectors to the rail (Top first).

Mount Safety Controller CPU with Other Module(s)

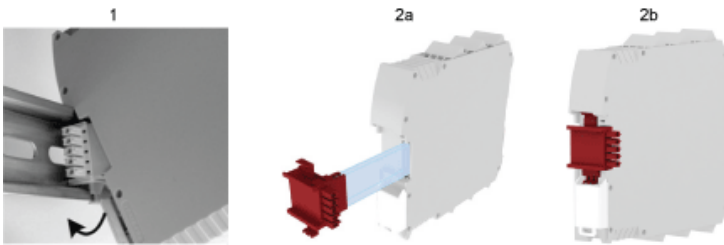

- 1 : Mount controller CPU and modules on rail.
- 2 : Make sure that the controller CPU or the module(s) are plugged on the BackPlane connector.

Wiring

Terminal Designation

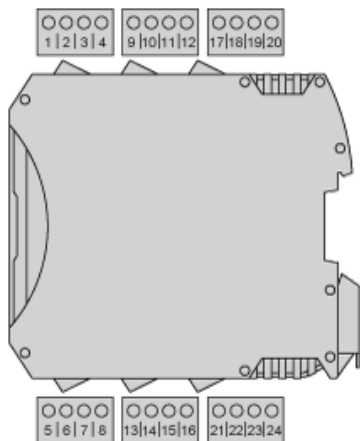

Terminal	Signal	Description
1	24 VDC	24 VDC power supply
2	NODE_ADDR0	Node selection
3	NODE_ADDR1	
4	0 VDC	0 Vdc power supply
5	PROXY1_24V	PROXIMITY 1 connections
6	PROXY1_REF	
7	PROXY1_NO	
8	PROXY1_NC	
9	PROXY2_24V	PROXIMITY 2 connections
10	PROXY2_REF	
11	PROXY2_NO	
12	PROXY2_NC	
13	not connected	not connected
14		
15		
16		