



TABLE OF CONTENTS

1. SPECIFICATIONS	3
2. SAFETY PRECAUTIONS	4
3. WARNINGS.....	6
4. OPERATION	7
5. COMPENSATION ADJUSTMENT.....	8
6. VOLTAGE DERATING CURVE	10
7. CLEANING.....	10



ATTENTION! PLEASE READ!



This Instruction Manual must be read thoroughly and understood completely prior to using this high voltage probe. This probe is designed to prevent accidental shock to the operator when properly used.

However, improper procedures or incorrect analysis of the measurement situation can result in serious shock or even death!

Strictly observe all safety precautions and warnings.

WARNING *This symbol and warning is used to indicate sections that may result in a serious injury or even death.*



CAUTION *This symbol and caution is used to indicate sections that only pose a risk of minor injury or physical damage.*



1. SPECIFICATIONS

Model	2387411
Division Ratio	1000:1
Input Resistance	900M Ω
Input Capacitance	2.0pF
Max. DC+AC peak	39kV CAT 0
Max. AC RMS.	27kV CAT 0
Max. Loading Current	45 μ A
Band Width	DC ~ 200MHz
Rise Time	1.6nS
Signal / Noise	>60dB @ 1KHz ; >50dB @ 1MHz
DCV Accuracy	\leq 3% (0 ~ 35kV)
ACV Accuracy	\leq 6% @ 1kHz
Temp. Coefficient	\leq 200 ppm/ $^{\circ}$ C
Compensation Range	10pF ~ 35pF
Safety	IEC61010-031:2015
Cable Length	2m \pm 0.2m
Operation Temp.	-10 ~ 55 $^{\circ}$ C
Humidity	85% RH or less (@ 35 $^{\circ}$ C)
Storage Temp.	-20 ~ 70 $^{\circ}$ C
Color: Handel / Body	Black / Grey
Weight / Volume	460g / 80(W) x 80(H) x 320(L) mm

2. SAFETY PRECAUTIONS



- *This high voltage probe must only be used by personnel who are trained, experienced, or otherwise qualified to recognize hazardous situations and who are trained in the safety precautions that are necessary to avoid possible injury when using such a device.*
- *For your own safety, inspect the probes for cracks and frayed or broken leads before each use. If defects are noted, DO NOT USE the probe.*
- *This probe is designed for use within Measurement Category 0 (CAT 0) only. Do not use the probe for measurements performed on circuits defined by any other measurement category.*
- *When measuring voltage source is over DC 30KV or AC 20KV, this probe is NOT suitable for long time using. High voltage source will have sparks in the air and cause high voltage source regular circuit does not have time to respond. This will have pulsed high voltage and which will cause this probe over rating and damage the product.
Do not exceed 60 seconds of contact between the probe and circuit-under-test when measuring voltages ≥ 30 kV DC or ≥ 20 kV AC (RMS). We recommend that an interval of at least 5 minutes be taken between measurements.*
- *Do not work alone when working with high voltage circuits!*
- *Hands, shoes, floor and work bench must be dry. Avoid making measurements under humid, damp or other environmental conditions that might affect the safety of the measurement situation.*

- *The probe body should be kept clean and free of any conductive contamination. Refer to the section on Cleaning.*
- *The probe is for indoor use only.*
- *If possible, always turn the high voltage source off before connection or disconnection the probe.*
- *This probe is grounded with the shell of BNC connector and an auxiliary grounding terminal, through the grounding conductor of the power cord of the measurement instrument. Before making connections to the input of this probe, ensure that the output BNC connector is attached to the BNC connector of the measurement instrument and the auxiliary grounding terminal is connected to a proper ground, while the measurement instrument is properly grounded.*

3. WARNINGS



- *The ground lead is critical to the safe operation of the probe. Failure to make this connection when making high voltage measurements may result in personal injury or damage to the probe or oscilloscope. This connection must always be made **BEFORE** the probe tip comes in contact with the high voltage and must not be removed until the probe tip has been removed from the high voltage source.*
- *If the probe was exposed to voltages over 39kV DC, or 27kV AC rms, then **DO NOT USE IT ANY LONGER**. The probe could potentially be damaged.*
- *Do not attempt to take measurements from the sources when the chassis or return lead is not grounded.*
- *Do not connect the ground clip to the high voltage source or the probe tip to the ground for any reason.*
- *Before turning the high voltage on, make sure that no part of your body is in contact with the device.*
- *Remember that the voltage being measured is 1000 times greater than the oscilloscope reading.*
- *Disconnect the probe tip from the high voltage source **BEFORE** removing the ground clip lead.*
- *Do not make any floating measurements with the RS-HVP 2739 High Voltage Probe.*

4. OPERATION

1. Connect the divider probe common lead (alligator clip) to a good earth ground or reliable ground.
2. Connect the BNC connector to the BNC input of your oscilloscope.
3. Select the desired range of your oscilloscope.



Whenever possible, turn the high voltage source off before making any connections.

5. COMPENSATION ADJUSTMENT

The following adjustment is required whenever the probe is transferred from one oscilloscope or input channel to another.

Connect the probe to the oscilloscope, apply a 200Hz square wave to the probe tip and adjust the oscilloscope controls to display a few cycles of the waveform. Adjust the trimmer located in the BNC plug for a flat-topped square wave.

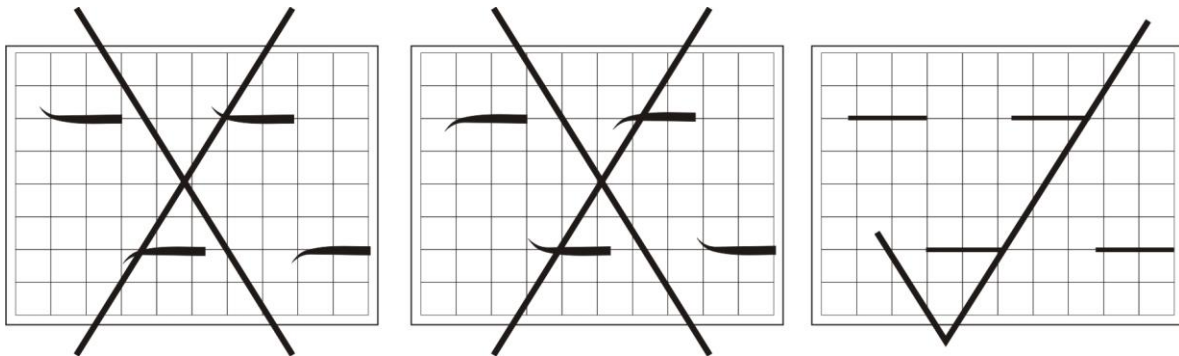
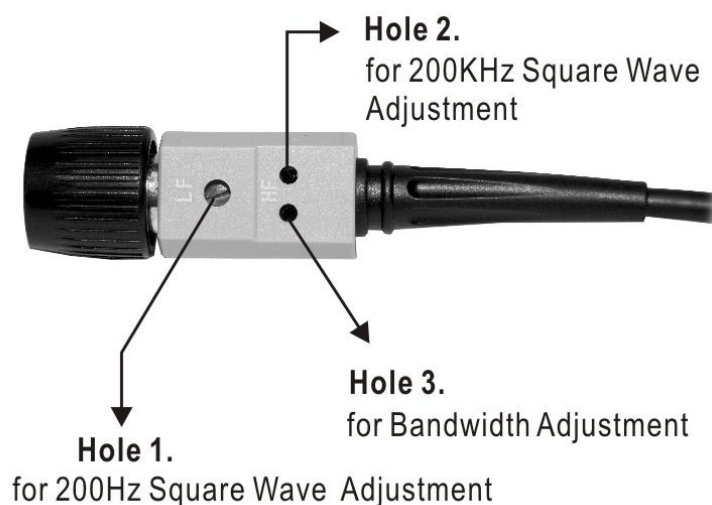

Illustration of 200Hz square wave adjustment.

Adjust the frequency response of the probe to match your oscilloscope by the adjust bar attached only.





WARNING, RISK OF DANGER!

- (1) The adjustment holes 2 and 3 are for the qualified engineer only.
- (2) Before adjusting hole 2 and hole 3, please move off the plastic cover at first.
- (3) Use the supplied adjust bar only.
- (4) When the measured frequency is over 40MHz or to adjust the bandwidth (hole 3), you must use the short earth lead and connect it to the alligator clip to for best frequency response.

(For 40MHz up
Measuring Frequency)



- (5) When the measured voltage is over 25kV, please connect high-voltage isolation head to the probe, to meet the regulations of 2006/95/EC Directive IEC61010-31:2015

HI-2high-voltage isolation head

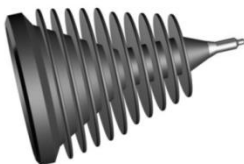

(connect the HI-25 & HVP-39pro)
connected to 2387411



6. VOLTAGE DERATING CURVE

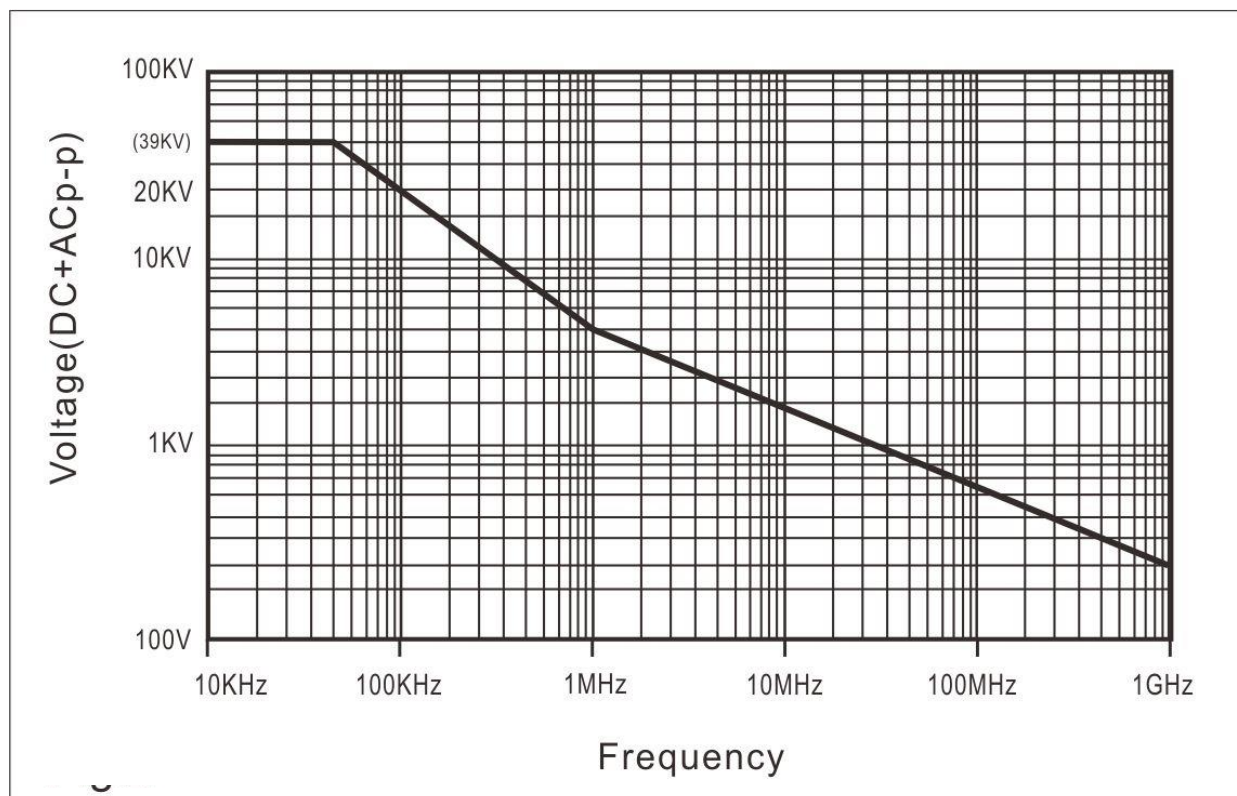

7. CLEANING

Clean only the exterior probe body and cables. Use a soft cotton cloth lightly moistened with a mild solution of detergent and water.



Do not allow any portion of the probe to submerge at any time.

Dry the probe thoroughly before attempting to make voltage measurement.



Do not subject the probe to solvents or solvent fumes as these can cause deterioration of the probe body and cables.



FOR MORE INFORMATIONS VISIT www.rs-components.com