

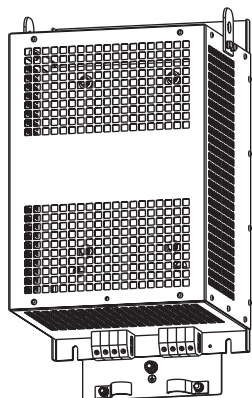

NHA1112506

# Output dv/dt filters ——— VW3A5301 ... 07 Metal kit IP21 ——— VW3A53902...903, VW3A53905

VW3A5301, VW3A5302,  
VW3A5303, VW3A5304,  
VW3A5305



VW3A53902  
VW3A53903  
VW3A53905

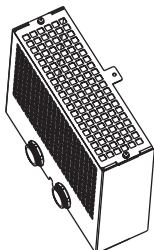

VW3A5306  
VW3A5307

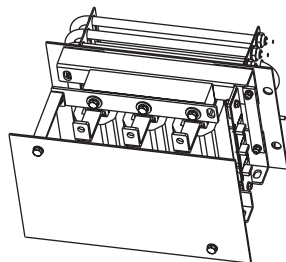

## **DANGER**

### HAZARD OF ELECTRIC SHOCK, EXPLOSION, OR ARC FLASH

- Only appropriately trained persons who are familiar with and fully understand the contents of the present manual and all other pertinent product documentation and who have received all necessary training to recognize and avoid hazards involved are authorized to work on and with this equipment.
- Installation, adjustment, repair, and maintenance must be performed by qualified personnel.
- Verify compliance with all local and national electrical code requirements as well as all other applicable regulations with respect to grounding of all equipment.
- Before performing work and/or applying voltage on the equipment, follow the instructions given in the appropriate installation manual.

**Failure to follow these instructions will result in death or serious injury.**

## **CAUTION**

### SHARP EDGES



Use all necessary personal protective equipment (PPE) such as gloves when performing any type of work whatsoever on or with this product.

**Failure to follow these instructions can result in injury or equipment damage.**



Schneider Electric Limited  
Stafford Park 5  
Telford, TF3 3BL, UK

Electrical equipment should be installed, operated, serviced, and maintained only by qualified personnel. No responsibility is assumed by Schneider Electric for any consequences arising out of the use of this product.  
© 2023 Schneider Electric. All Rights Reserved.

OUTPUT DV/DT FILTERS		METAL KIT IP21
VW3A5301	6A	VW3A53902
VW3A5302	15A	VW3A53902
VW3A5303	25A	VW3A53902
VW3A5304	50A	VW3A53903
VW3A5305	95A	VW3A53905
VW3A5306	180A	-
VW3A5307	305A	-

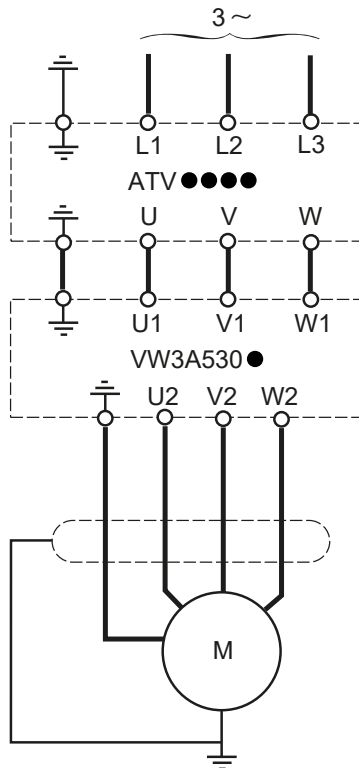

VW3A5301  
 VW3A5302  
 VW3A5303  
 VW3A5304  
 VW3A5305

VW3A5301 + VW3A53902  
 VW3A5302 + VW3A53902  
 VW3A5303 + VW3A53902  
 VW3A5304 + VW3A53903  
 VW3A5305 + VW3A53905

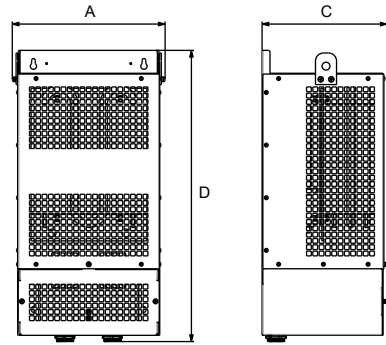
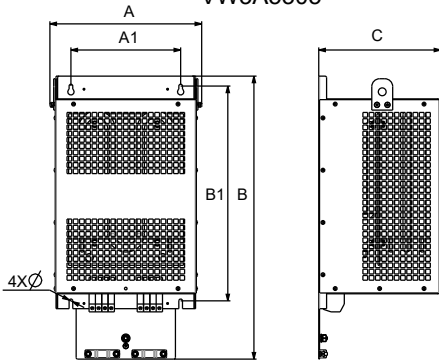

OUTPUT DV/DT FILTERS	A		B		C		D		A1		B1		Ø	
	mm	in	mm	in	mm	in	mm	in	mm	in	mm	in	mm	in
<b>VW3A5301 + VW3A53902</b>	295	11.6	525	20.7	215	8.5	535	21.1	210	8.3	411	16.2	7	0.28
<b>VW3A5302 + VW3A53902</b>	295	11.6	525	20.7	215	8.5	535	21.1	210	8.3	411	16.2	7	0.28
<b>VW3A5303 + VW3A53902</b>	295	11.6	525	20.7	215	8.5	535	21.1	210	8.3	411	16.2	7	0.28
<b>VW3A5304 + VW3A53903</b>	300	11.8	545	21.5	245	9.6	560	22.0	210	8.3	411	16.2	7	0.28
<b>VW3A5305 + VW3A53905</b>	300	11.8	590	23.2	245	9.6	610	24.0	210	8.3	411	16.2	7	0.28

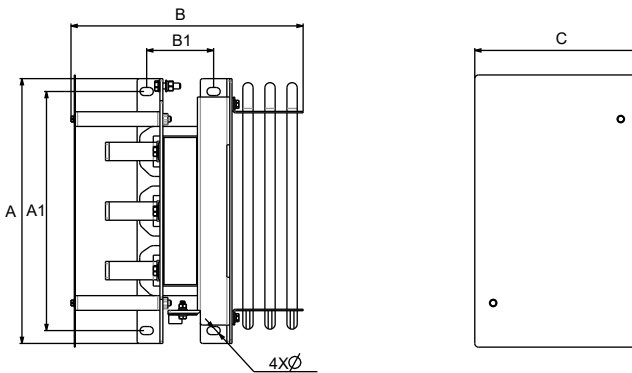

OUTPUT DV/DT FILTERS	A		B		C		A1		B1		Ø	
	mm	in	mm	in	mm	in	mm	in	mm	in	mm	in
<b>VW3A5306</b>	380	15.0	350	13.8	235	9.3	325	12.8	91	3.6	11	0.43
<b>VW3A5307</b>	420	16.5	360	14.2	270	10.6	360	14.2	116	4.6	11	0.43

VW3A5301, VW3A5302,  
VW3A5303, VW3A5304,  
VW3A5305

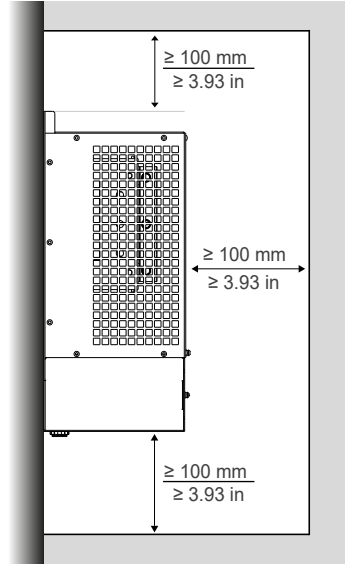
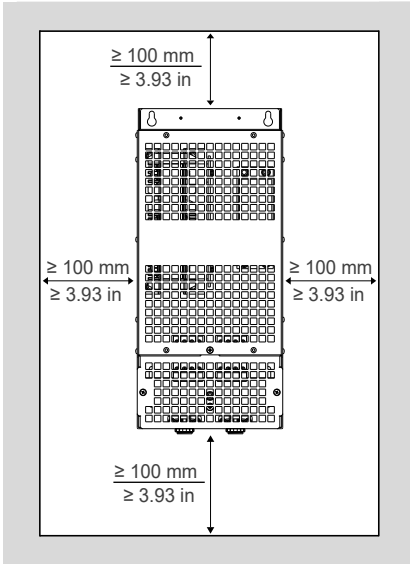
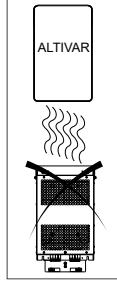

VW3A5306, VW3A5307

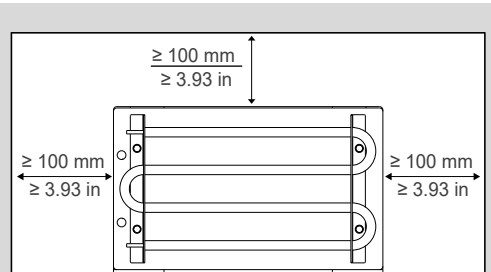
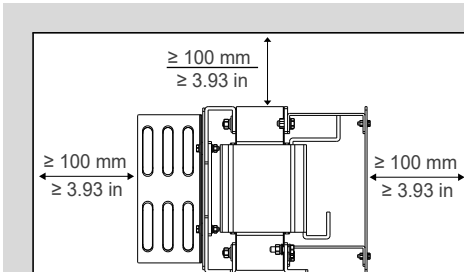

1

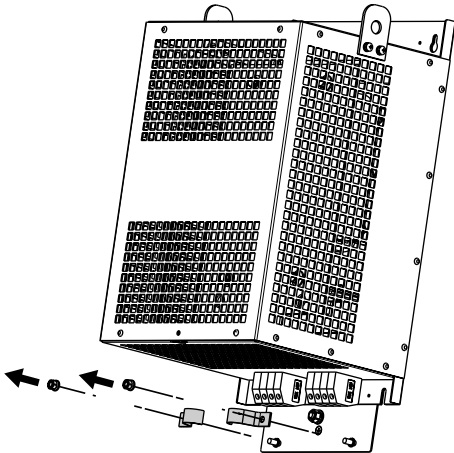

2

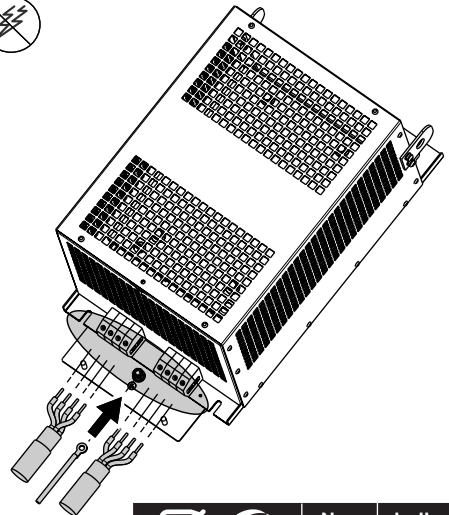

	N.m	in-lb
VW3A5301 ... 03	1.45	13
VW3A5304	2.82	25
VW3A5305	4.52	40

3

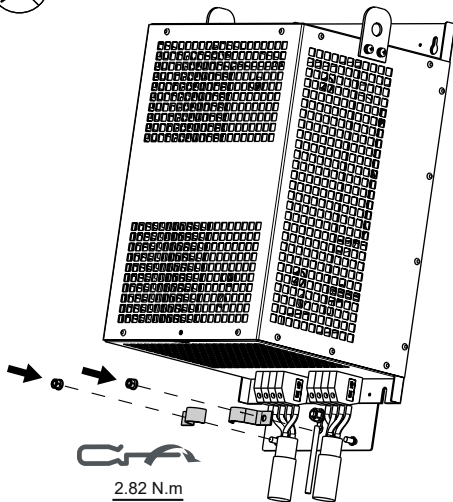

2.82 N.m  
25 in-lb

4

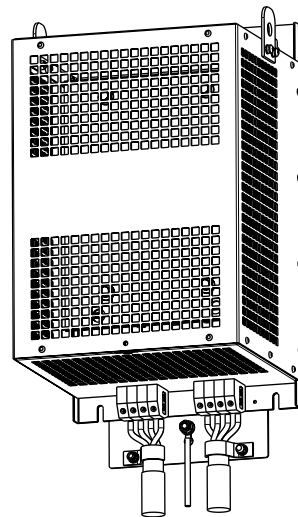

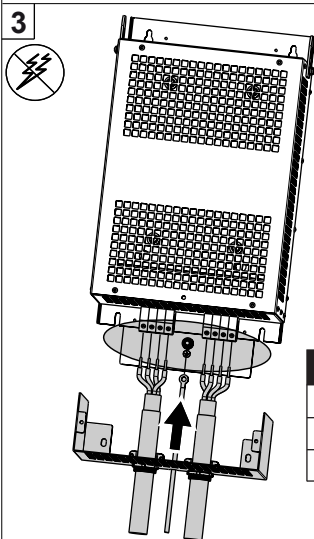
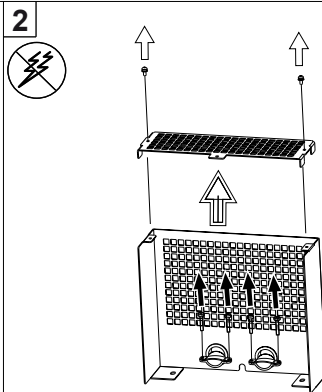
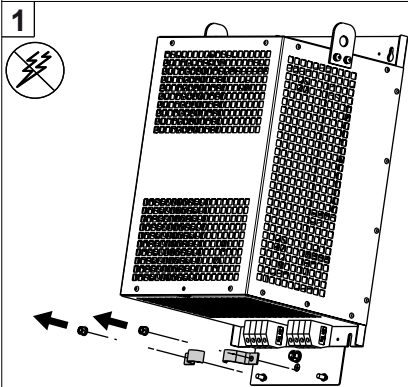

	N.m	in-lb
VW3A5301 ... 03	1.45	13
VW3A5304	2.82	25
VW3A5305	4.52	40

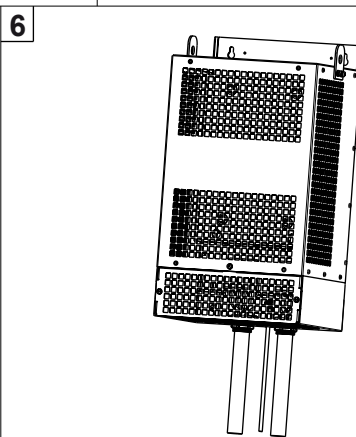
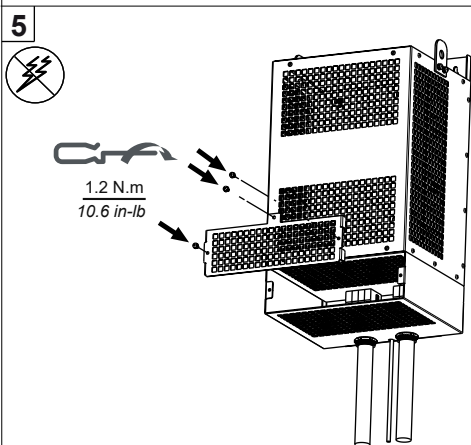
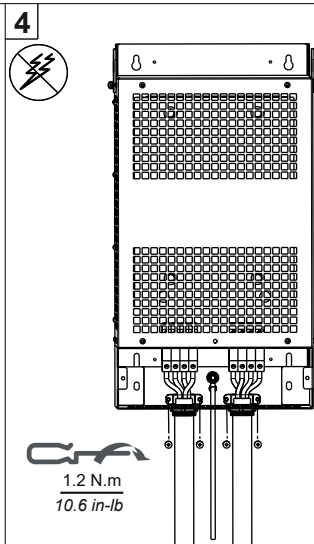

1

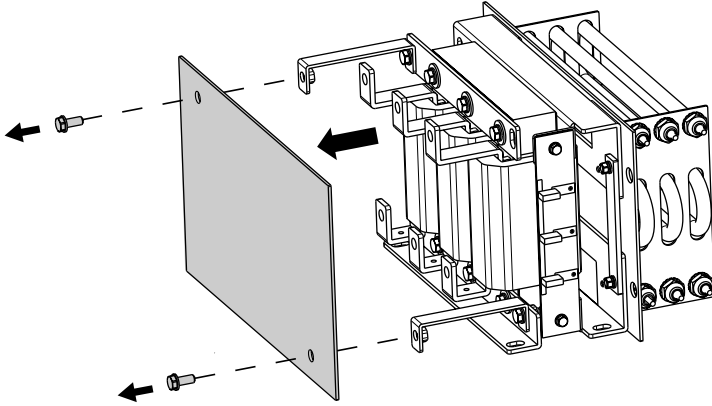

2

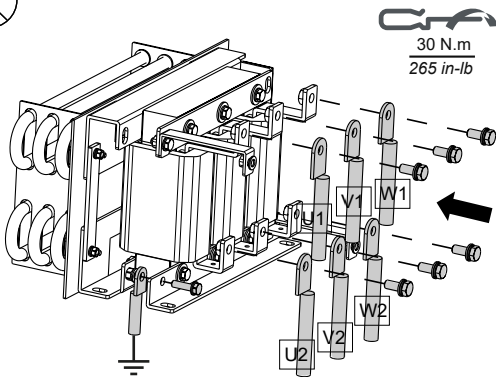

4

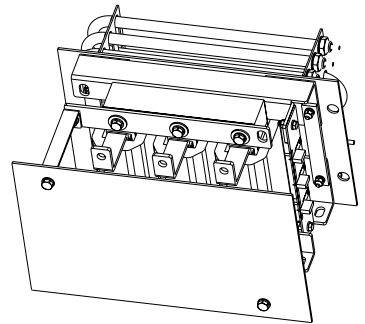

3

