

Datasheet

519-236 Float Switch



Electrical Characteristics @25°C

Contact form	A	
Contact material	Ru	
Contact rating max.	W / VA	10
Switching current max.	A	1.0
Carry current max.	A	1.2
Switching voltage max.	VDC	200
	VAC	140
Breakdown voltage min.	VDC	240

Temperature Range

Operating temperature	°C	-20 to +80
Storage temperature	°C	-30 to +80

Material

Polypropylene (PP)	Water, dilute acids
Polyamide (PA)	Oil, gasoline (petrol), brake fluid

Use in

Dimensions

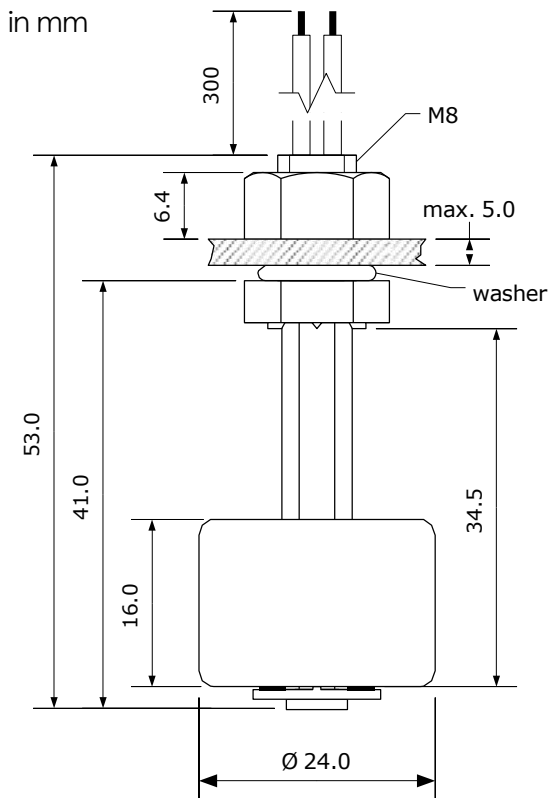

Operating diagram

