

**Professionally approved products.  
Datasheet**

**RS 15 Way, Type H15 Class C3, 2 Row z/d, Right Angle DIN 41612 Connector, Plug, Solder**

RS Stock 542-4631

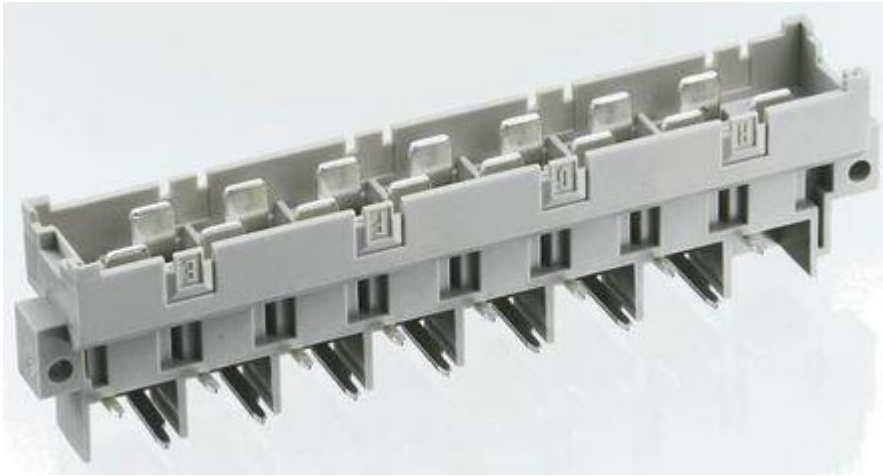

**Dimensions: (mm)**

Male connector

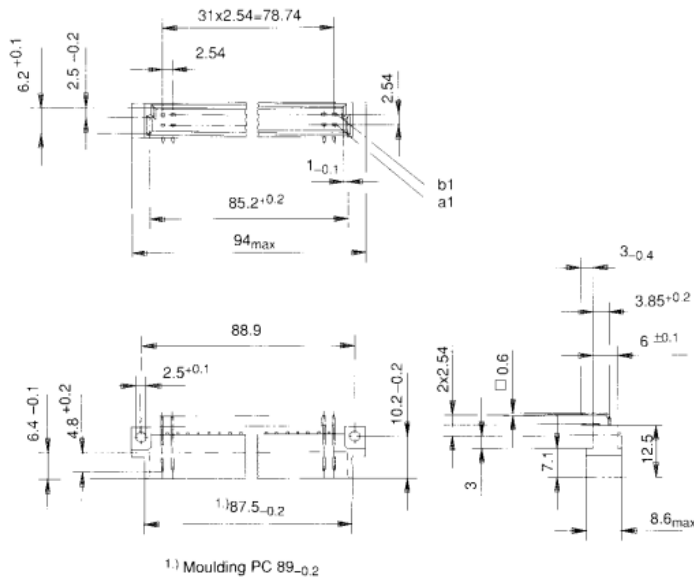

Female connector

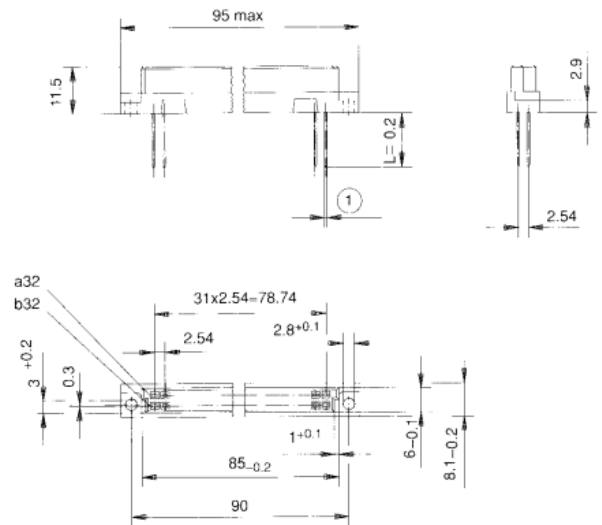

① connectors for dip soldering are available with terminations of 0.25x0.7mm or 0.6x0.6. Wire-wrap-terminations 0.6x0.6mm..

# Professionally approved products.

## Datasheet

### Electrical and mechanical data

Type		B	C	D	E	F	H	
Reversed Type		Q	R					
Max. number of contacts		64	96	32	48	48	11 15	
Contract row designation of male and female connectors		ab	abc	ac	ace	zbd	b zd	
Temperature range		- 65° . . . + 125°C						
Permissible humidity		Annual average ≤ 80%, max. 100%						
Creepage (Cr) and clearance (Cl) in mm	Contact to ground	Cr	1.8		1.8		6.0	8.0
		Cl	1.6		1.6		3.5	4.5
	Contact to contact within a row	Cr	1.2		3.0		3.0	8.0
		Cl	1.2		3.0		1.6	4.5
	between a row	Cr	1.2		3.0		3.0	8.0
		Cl	1.2		3.0	3.0 (1.6)*	1.6	4.5
Current rating at ambient temperature	A							
	+20°C (293K)		4.0		5.5		20.0	
	+70°C (343K)		2.0		4.0		15.0	
	+100°C (373K)		1.0		2.5		10.0	
Test voltage, 50Hz, 1min								
Contact/contact	Vrms		1000		1550		3100	
Contact/ground	Vrms		1550		1550		3100	
Contact resistance	mΩ		≤ 20		≤ 15		≤ 8	
Insulation resistance	Ω				≥ 10 <sup>12</sup> at 100 VDC			
Shock and vibration proofness					no contact breakdown at 20g and 10...2000Hz			
Housing material of male and female connectors					PBT 30 % GV PC 30 % GV			
Comparative creepagefigure to DIN IEC 112	PBT PC				CTI 275 / CTI 175 M CTI 150-175 / CTI 100 M			
Service life to DIN 41 612, Part 5					Performance level 1 ≥ 500 Mating-cycles Performance level 2 ≥ 400 Mating-cycles			
Mating and withdrawal force for the assembled connectors	N	64pin.60	96pin.90 64pin.60 32pin.30	32pin.40	48pin.60 32pin.40	48pin.75 32pin.50	15pin.90 11pin.80	
Withdrawal force per contact (test blade)	N		≥ 0.15			≥ 0.2		
Inflammability of the plastic	PBT PC		Polybutylenterephthalat non flammable as per UL 94 V-0 Polycarbonat non flammable as per UL 94 V-1					

# Professionally approved products.

## Datasheet

### Example of an application



Male and female connectors of the size B connectors can be used with our cable housings series KSG 173.

However an adapter is required.

With the necessary guide parts and guide frames of the KSG interface system a connection from the front panel and the wiring field side can be realized in the 19" chassis.

## General information

The DIN 41612/IEC 60603-2 connector family consists of 13 basic sizes and many complementary versions.

It was developed for use in 19" rack systems in accordance with **DIN 41494**. The large number of different sizes and the efficient connection techniques have made it possible to install these connectors for an extremely wide range of applications.

Typical areas of application:

- Connection between plug-in card and back-panel wiring
- Connection between two PCB's arranged one above the other
- Connection to peripheral equipment with connector housings as accessories
- As periphery connectors for external interfaces from the wiring side

## Early make/last break

For the connectors size B, C, Q, R, D, E and F 0,8 mm early make/last break male contacts can be loaded in any position in rows a, b, c, d, e and z.

The early make/last break of the high current connectors size H11 and H15 have a length of 3,5 mm (1,5 mm on request). Other lengths of early make/last break contacts on request.

## Main features

- Two piece printed circuit board connectors
- International approvals, such as UL or CSA
- 13 connector sizes with the same plugin and mounting conditions
- Additional connector sizes complementing the DIN 41612/IEC 60603-2
- Different coding available
- Up to 160 pins/contacts
- Two to five row connectors possible
- Various termination types available
- 2.54 mm (1/10") basic pitch
- Early make/last break contacts available on request
- Wide range of accessories
- Complete interface system available
- All female connectors mentioned in this data sheet have **dual sided female contact spring.**

This contact principle even offers a max. security in contacting and remaining contact resistance in extreme situations.

## Approval certificates

**UL** All male and female connectors of this data sheet are approved by the American approvals authority „Underwriters Laboratories Inc.“ File Nr. E 84703.

**CSA** For all our male and female connectors we have the recognition of the „Canadian Standard Association“ under the File Nr. LR 62504.

# Professionally approved products.

## Datasheet

### Pre-centering

For applications with early make/last break contacts the male connector insulators with pre-centering ensures even more reliable mating.

The insulators of the female connectors have a recess at an appropriate point. The dimensions of these versions do not conform to the specifications of DIN 41612/IEC 60603-2. The ordering details are not listed in this data sheet but they can be supplied on request.

**Male connectors with pre-centering do not fit female connectors without a pre-centering recess.**

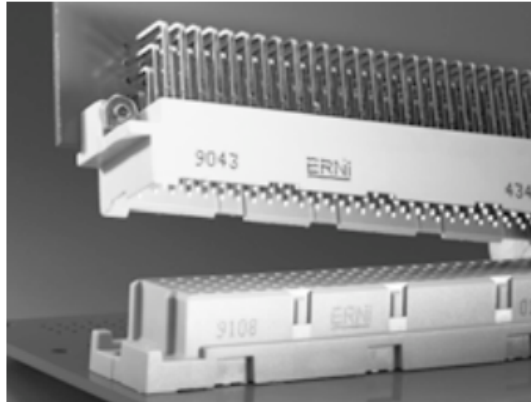

### Codings

Various coding systems are available for the connectors contained in this data sheet.

- Integrated coding with coding wedges. In this case coding wedges are fitted into the female connectors and the male connectors are provided with corresponding recesses.
- Integrated coding with coding pins. In this case coding pins are inserted into the female connectors and holes are drilled in the male connectors in the coding positions.
- Coding with coding strips. These coding strips are mounted together with the connector. For ERNI coding strips no extra modular space is required in the 19" rack system.

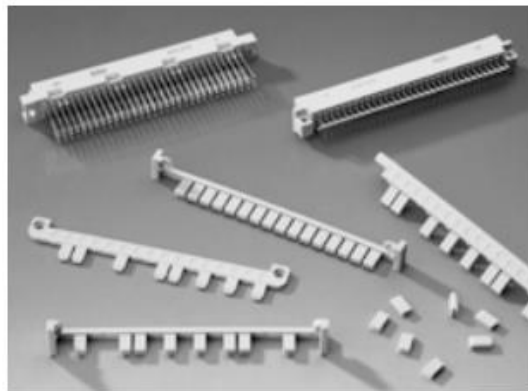

### Retentive clip

For efficient mounting of the right angle connectors ERNI offers a retentive clip.

These clips are installed to the connector by ERNI. The connectors are attached to the pc board with this clip, which locks into the drillholes on the pc board, max. thickness of pcb = 1,6 mm.

Since the clips can also be soldered, plated-through PCB holes are recommended in such applications. Connectors with retentive clips are available upon request.

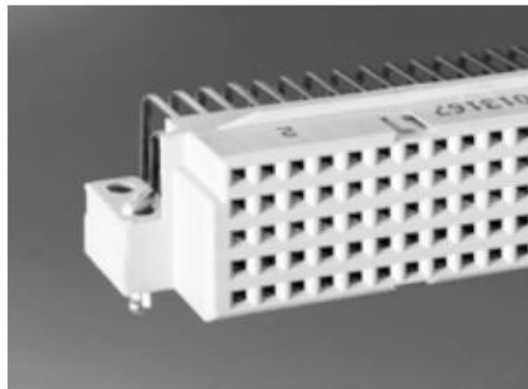

### Wiring accessories

The ERNI connector housing range together with the ERNI interface connector system offers optimum protection for all plug-in interfaces for DIN 41612/IEC 60603-2 connectors. The range is dimensioned for the 19" rack system. Suitable variants are available for virtually every type of connector. Whether you intend to use a short type B/2 connector or a 64-pin insulation displacement connector, the ERNI range offers you the ideal housing.

- **KSG 173** Size: B, C, D, E, M, H11, H15, Q, R, E160, TE160, RD128
- **KSG 193** Size: B/2, C/2, Q/2, R/2
- **KSG 203** Size: F, Fi
- **KSG 253** Size: C (IDC)
- **KSG 204** Size: F, Fi

The connector housings are prepared for a maximum of 3 cable outlets and are fitted with strain-relief clamps. A metal-plated version for screening purposes is also available. For plug-in interfaces on the front or back panel of the rack ERNI has developed guide elements and guide frames in collaboration with well-known users. These elements permit exact guidance for correct mating and provide robust screw locking. In addition you can fit a coding device.



# Professionally approved products. Datasheet

## Size C

as per DIN 41612/IEC 60603-2



### Dimensional drawings

Male connector

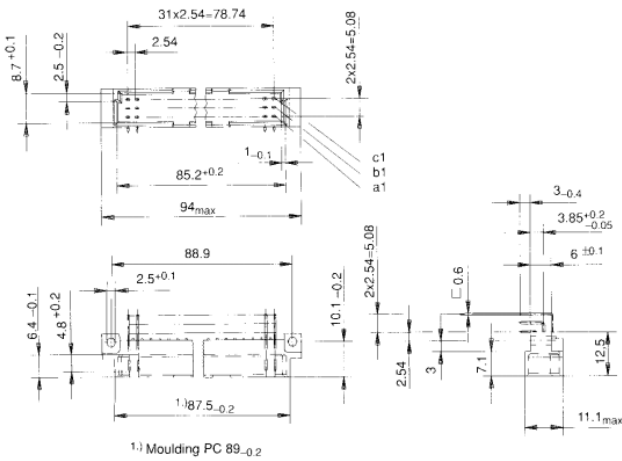

Female connector

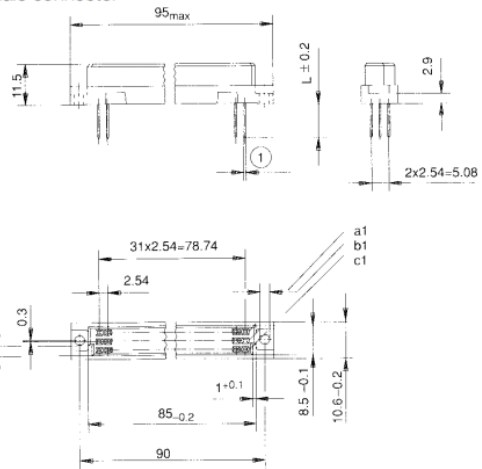

① connectors for dip soldering are available with terminations of  $0.25 \times 0.7 \text{ mm}$  or  $0.6 \times 0.6$ .  
Wire-wrap-terminations  $0.6 \times 0.6 \text{ mm}$ .

# Professionally approved products. Datasheet

## Example of an application



For female connectors with hard gold plated transfer zone terminations, ERNI offers a specific guide frame for the design in the wiring field or on the front panel in a chassis.

For ordering details regarding the ERNI interface system please refer to the data sheet titled „Mateable wiring transfer system“.

# Professionally approved products. Datasheet



## Dimensional drawings

Male connector

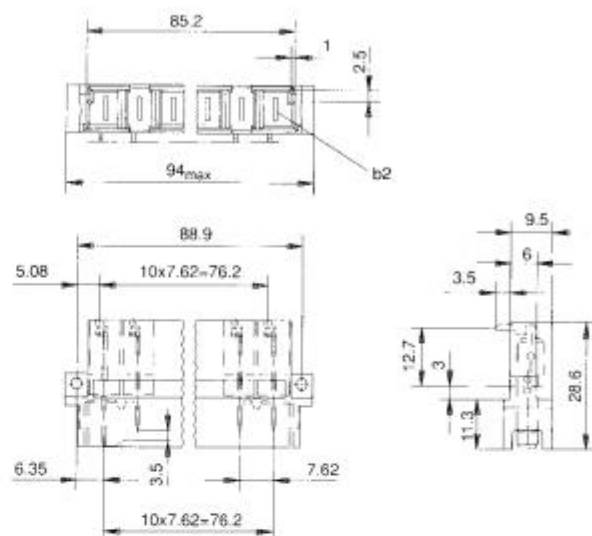

Female connector  
with quick disconnect terminations

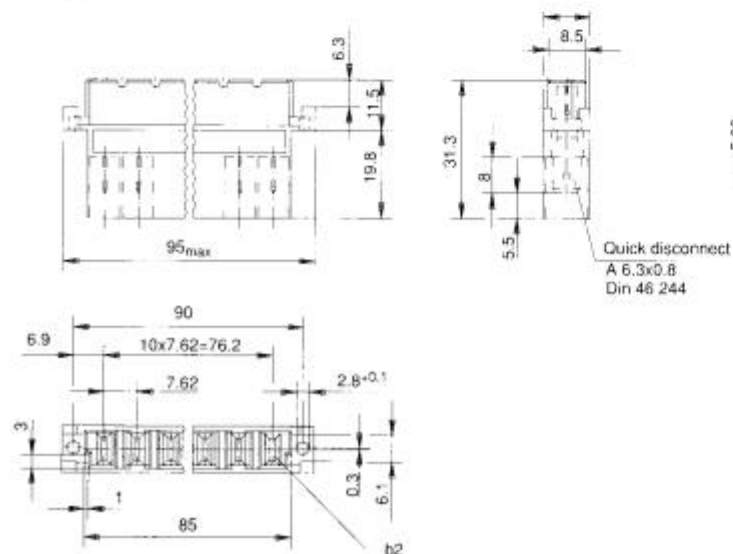

Female connector  
with dip solder terminations

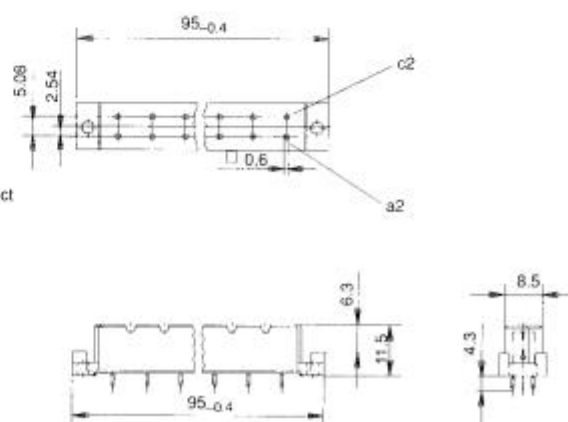

please refer to the pcb pattern on page 41

# Professionally approved products. Datasheet



## Dimensional drawings

Male connector

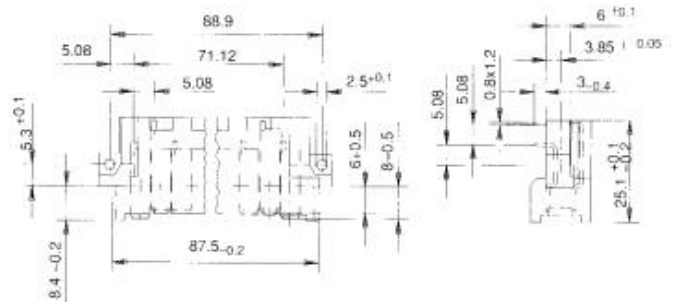
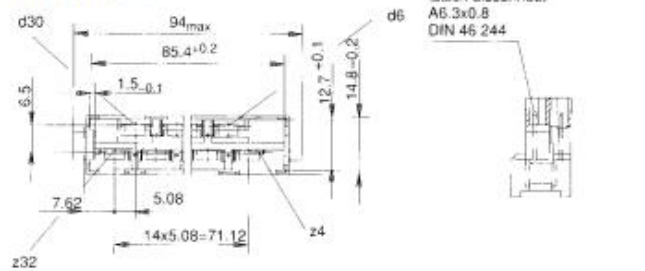

Female connector  
with quick disconnect termination

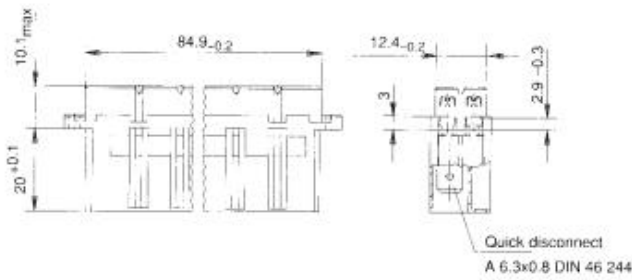

Female connector  
with dip solder termination

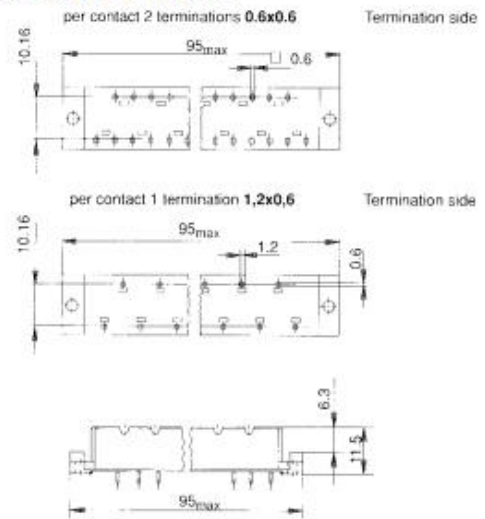

please refer to the pcb pattern on page 41

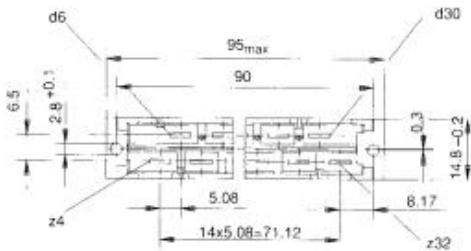



# Professionally approved products. Datasheet

## H Series

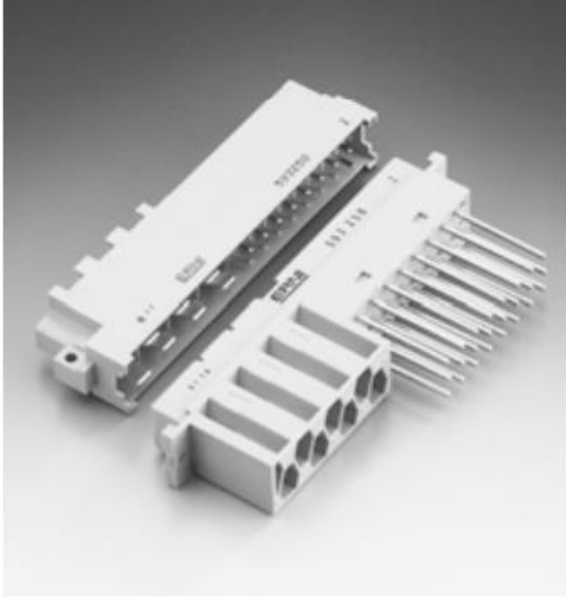

### Dimensional drawings

Male connector

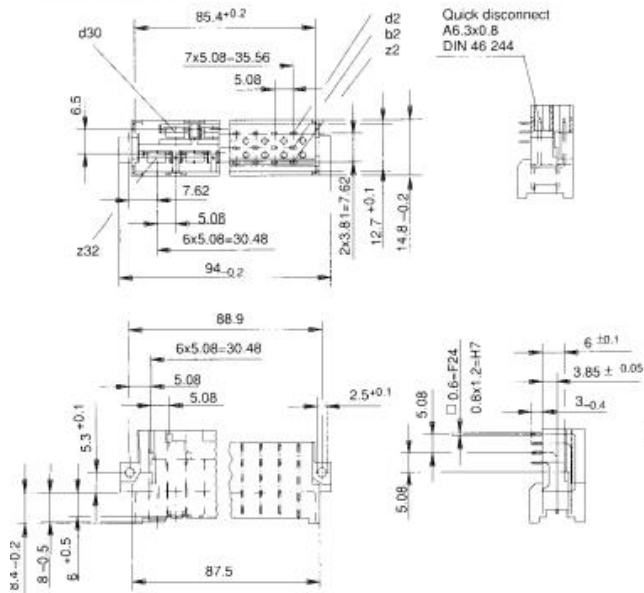

Female connector

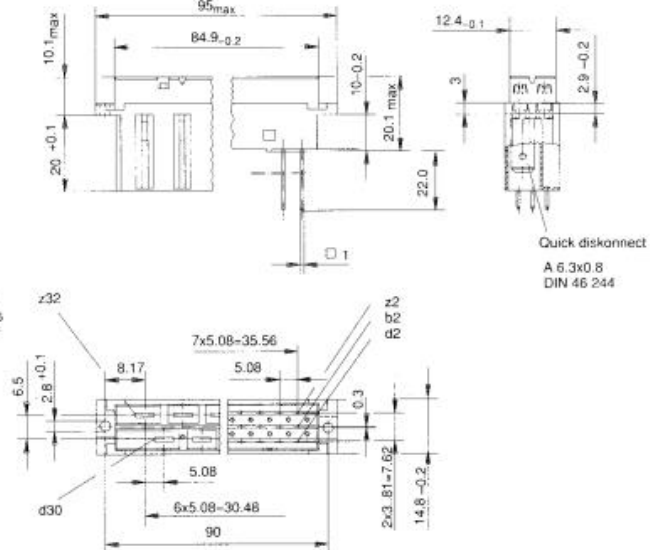

# Professionally approved products. Datasheet

## Size R

inverse size as per DIN 41612/IEC 60603-2



## Dimensional drawings

Male connector

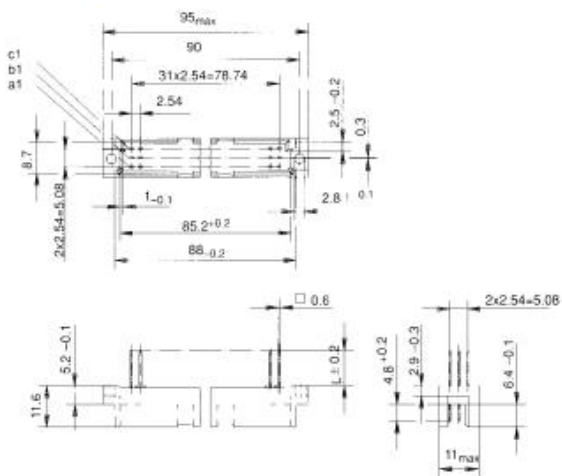

Female connector

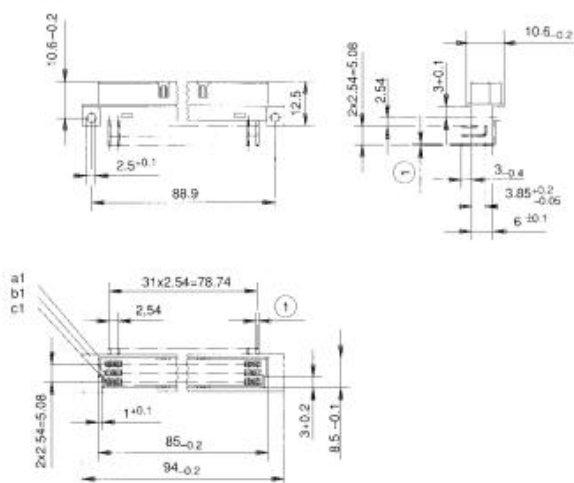

① alternatively with 0.6x0.6mm or 0.28x0.7mm terminations available.

# Professionally approved products. Datasheet

## Example of an application

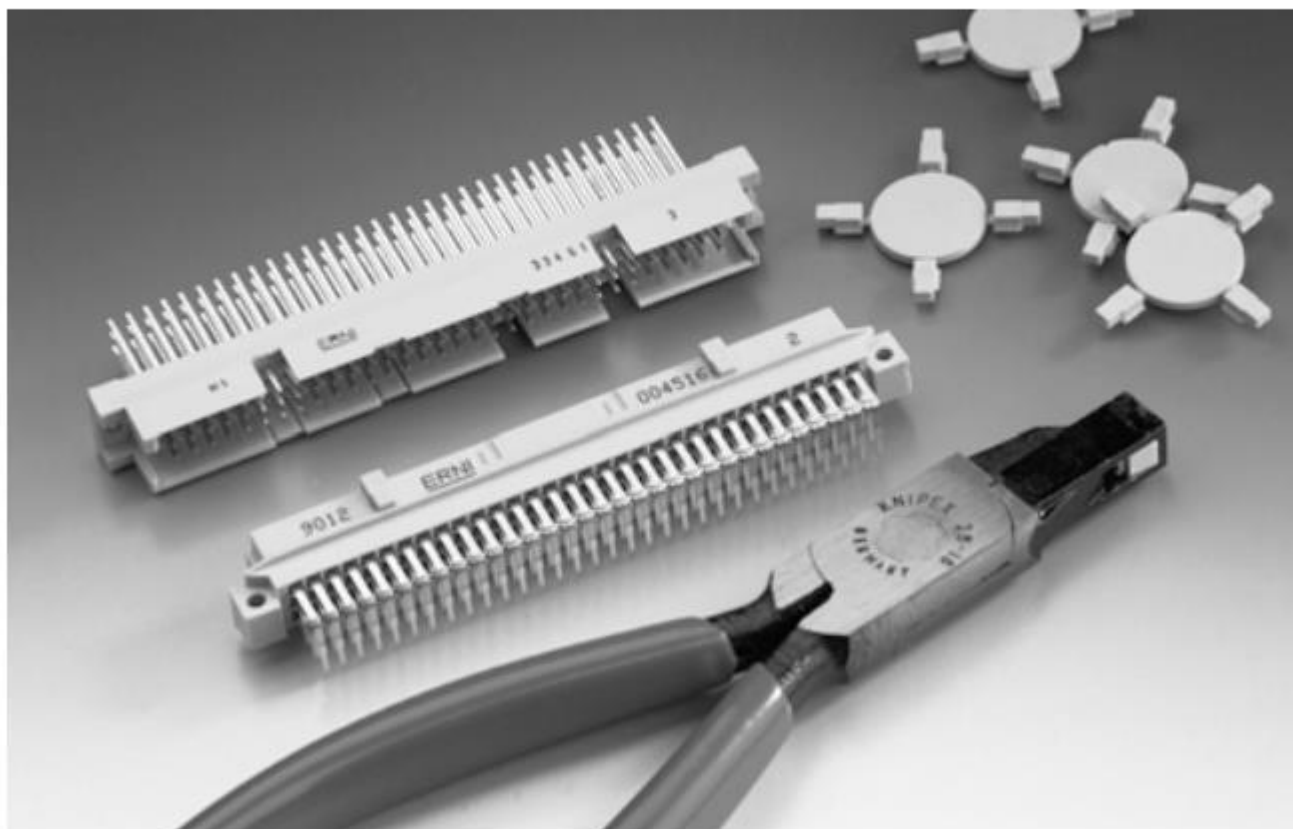

The reverse connectors of the sizes Q and R are provided with integral coding. With a pair of pliers the coding positions on the male connectors are removed. On the same positions on the female connectors coding tabs are inserted.

With this coding system a max. of 70 coding possibilities are possible.

The ordering information for the coding tabs and the pair of pliers you will find in the data sheet „Coding“.

# Professionally approved products.

## Datasheet

### Size D

as per DIN 41612/IEC 60603-2



### Dimensional drawings

#### Male connector

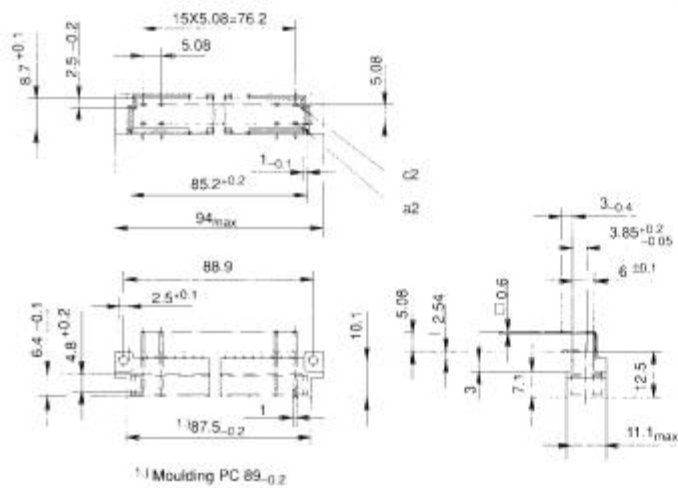

#### Female connector

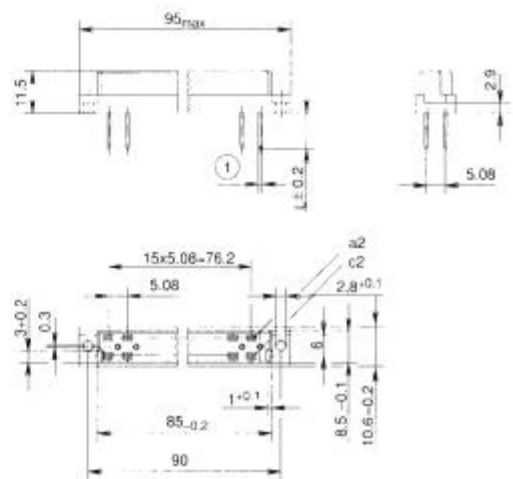

- ① connectors for dip soldering are available with terminations of 1x1mm or 0.6x0.6. Wire-wrap-terminations 1x1mm.

# Professionally approved products. Datasheet

## Size E

as per DIN 41612/IEC 60603-2



### Dimensional drawings

Male connector

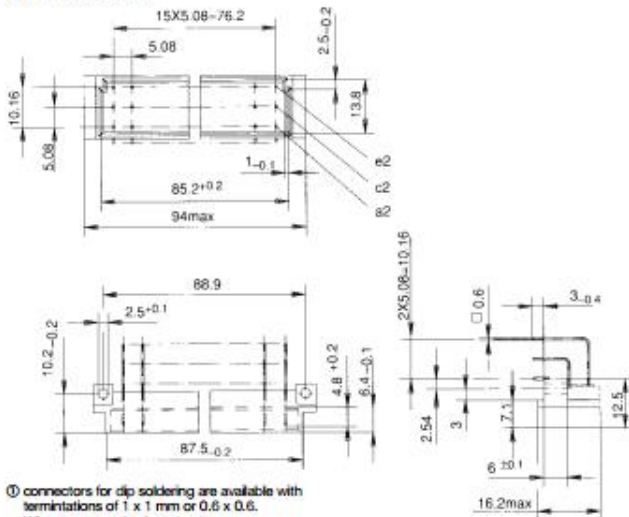

① connectors for dip soldering are available with terminations of  $1 \times 1 \text{ mm}$  or  $0.6 \times 0.6$ .  
Wire-wrap-terminations  $1 \times 1 \text{ mm}$ .

Female connector

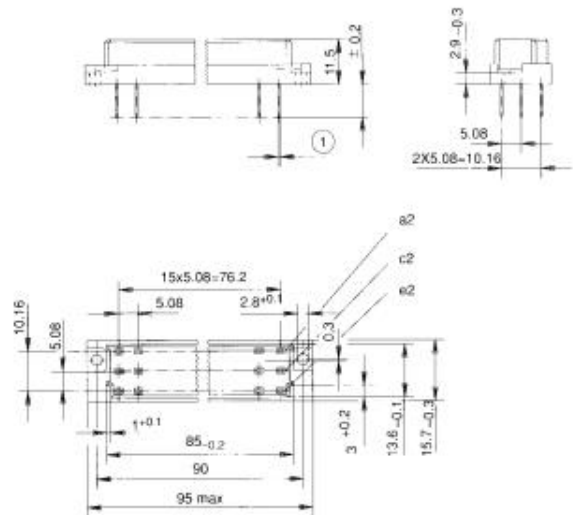

# Professionally approved products. Datasheet

## Size F

as per DIN 41612/IEC 60603-2

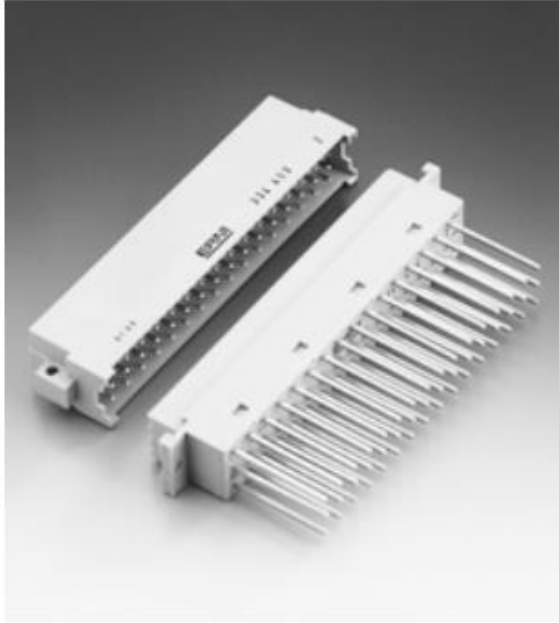

## Dimensional drawings

Male connector

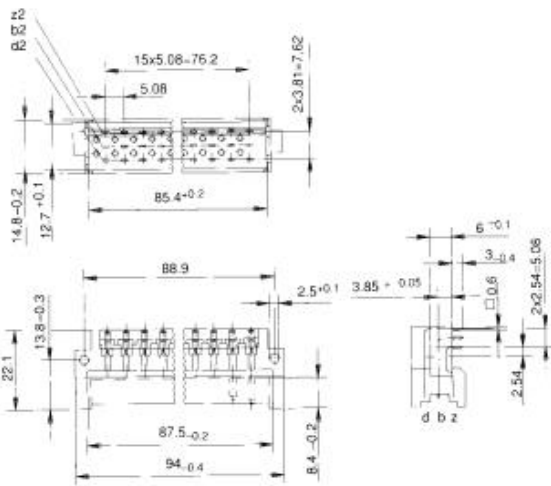

Female connector

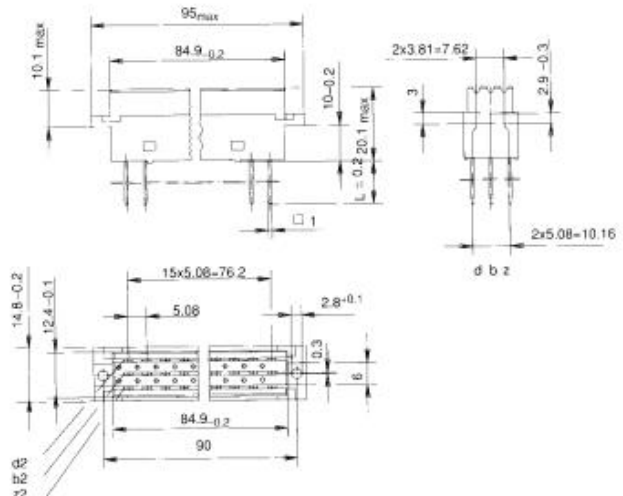

# Professionally approved products. Datasheet

## Size Q

inverse size as per DIN 41612/IEC 60603-2



## Dimensional drawings

Male connector

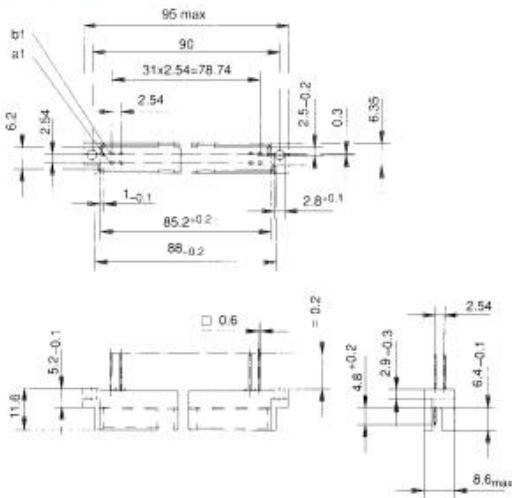

Female connector

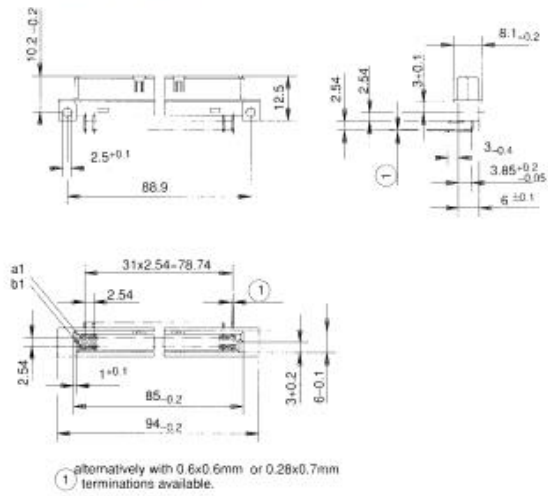

# Professionally approved products. Datasheet

## Common dimensions for all sizes of the connector family as per DIN 41612/IEC 60603-2

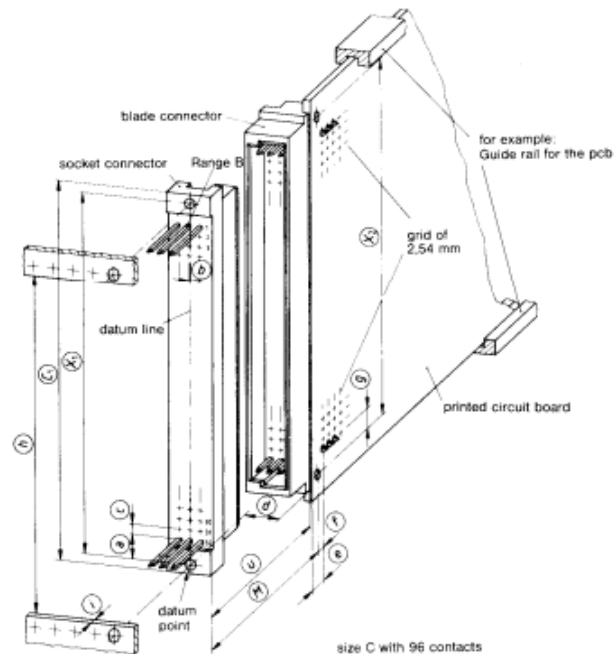

### Important dimensions

Letter of dimension	Dimensions mm	Explanation
(C <sub>1</sub> )	95	Maximum length of the connector assigned to the back panel
(M)	15.5 bis 17,3	Mating zone for reliable contact making
(X <sub>1</sub> )	90	Distance between the mounting holes of the connector assigned to the back panel
(X <sub>2</sub> )	88.9	Distance between the mounting holes of the connector assigned to the assembly
(a)	5.63	Distance between the reference point and centerline through contact no. 32 with regard to the connector assigned to the back panel
(b)	0.3	Distance between the reference line (line through the fixing holes) and centerline of row b (also called offset)
(c)	nx2.54	Pitch of the terminals of the connector assigned to the back panel)
(d)	3.55	Distance between the reference line and the component side of the PCB
(e)	5.3	Distance between the edge of the PCB and the first row of holes for terminals of the connector mounted on the assembly
(f)	2.54	Distance between the mounting holes and the first row of holes for terminals of the connector mounted on the assembly
(g)	5.08	Distance between the mounting holes and the holes for contacts no. 1 and no. 32 of the connector assigned to the assembly
(h)	85	Minimum length of the panel cutout or minimum distance between the mounting rails for the connector assigned to the back panel
(i)	2.5	Maximum thickness of mounting plate or mounting rails
(u)	12.4 bis 14.2	Mating zone for reliable contact making



# Professionally approved products. Datasheet

## Mounting dimensions of the connectors

in the module spacing of the 19" rack system

Exact position of the connectors  
in the **size C** module spacing

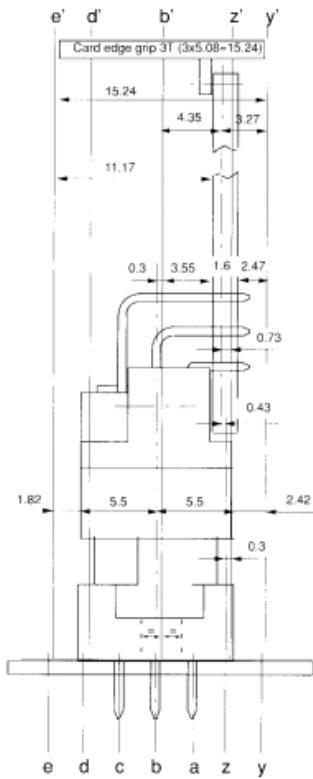

Exact position of the connectors  
in the **size E** module spacing

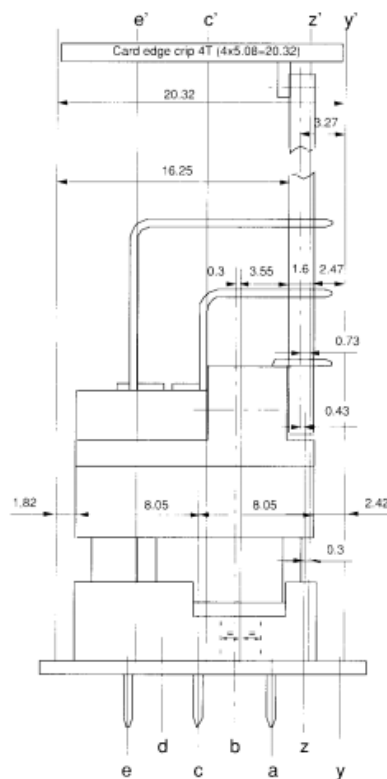

Exact position of the connectors  
in the **size F** module spacing

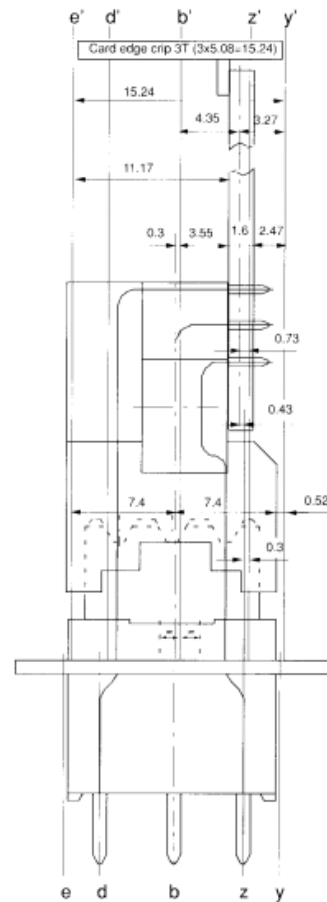

These drawings contain important dimensions for the use of DIN 41612/IEC 60603-2 connectors in 19" rack systems.

The mounting dimensions shown for size F connectors illustrates how the width of 3 x 5.08 mm is maintained by means of the pitch offset between mating side and soldering side. Thus size F connectors can still be mounted in the 3 x 5.08 mm module.

# Professionally approved products. Datasheet

## Clearances and creepage distances

for DIN 41612/IEC 60603-2 male and female connectors

Two different creepage distances and clearances are always distinguished for connectors:

1. The distances a and b as the shortest creepage distance and clearance between assembly rail (chassis) and the closest terminal post.
2. The distances c and d as the shortest creepage distance and clearance between 2 adjacent terminal posts in unwrapped state.

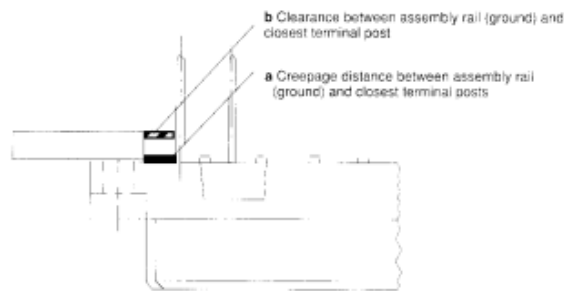

All the values apply to the connectors prior to their termination to the printed circuit board. The influence of the wiring on the creepage distance and clearance must be taken into account.

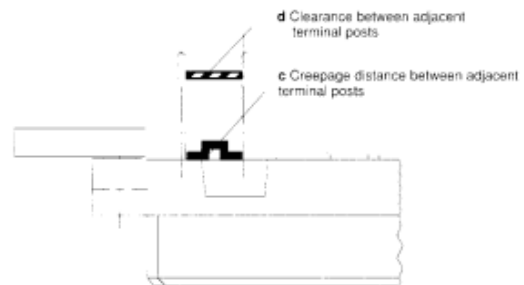

## Minimum clearances and creepage distances according to IEC 60664

When calculating the minimum clearance and creepage distance for your application, the guidelines contained in IEC 60664 Parts 1 and 2, January 1989 issue are applicable. This standard contains the relevant values in tabular form.

### Calculation of minimum **clearance**:

The minimum clearance primarily depends on the following factors:

- Rated impulse voltage for clearances (depending on overvoltage category).
- Degree of contamination

This standard can be obtained from vde-verlag gmbh, Berlin 12 and Offenbach.

### Calculation of minimum **creepage** distance:

The minimum creepage distance is primarily dependent on the following factors:

- Rated voltage
- Degree of contamination
- CTI values (comparative tracking index) of the insulation material
- Shape of the moulding

# Professionally approved products. Datasheet

## Mounting hole pattern, PCB

### Male – and female connectors

as per DIN 41612/IEC 60603-2, with straight terminations, view of equipment side

Female size H11

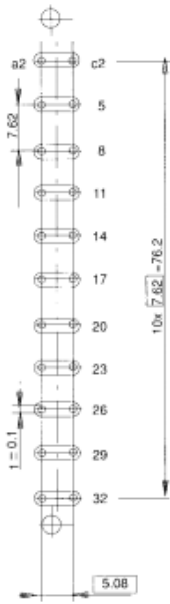

remaining dimensions  
as per hole pattern 1

Female size H15  
per contact 2 terminations

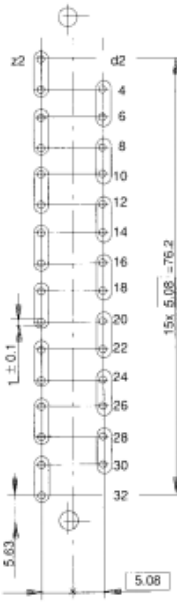

remaining dimensions  
as per hole pattern 1

Female size H11

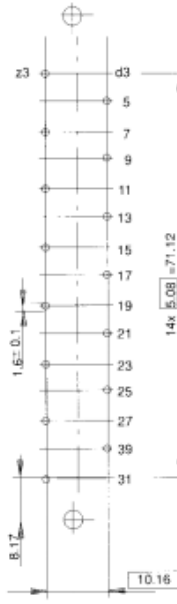

remaining dimensions  
as per hole pattern 1

Female size H15  
per contact 2 terminations

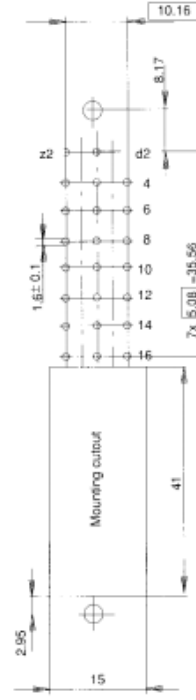

remaining dimensions  
as per hole pattern 1

### Mating conditions (overlapping security)

see example size C

The connectors as per DIN 41612/IEC 60603-2 are produced so that the tolerance buildup, which can develop during installation, will not lead to any misalignment. On the mated pair it has to be ensured that the for each connector sizes permissible min. length of the male contact ist within the tolerance of  $\text{Ⓢ}=12.4 \text{ mm}$  till  $14.2 \text{ mm}$  in order to meet the current flow resistance.

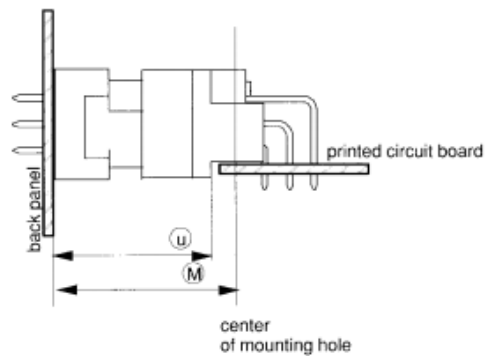

# Professionally approved products.

## Datasheet

### Mounting hole pattern, PCB

#### Male – and female connectors

as per DIN 41612/IEC 60603-2, right angle terminations, view of equipment side

Female size B ①

Female size C

Male size Q ①

Male size R

Female size D

Female size E

Female size F

Hole pattern 1

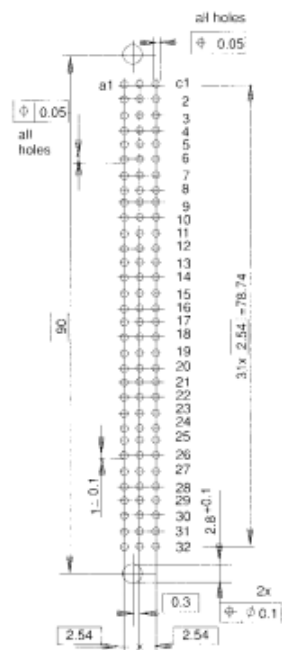

remaining dimensions  
as per hole pattern 1



remaining dimensions  
as per hole pattern 1

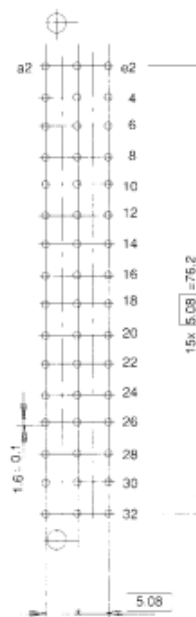

remaining dimensions  
as per hole pattern 1

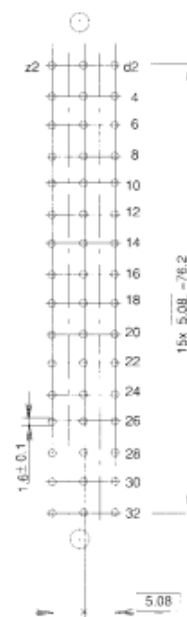

# Professionally approved products. Datasheet

## Mounting hole pattern, PCB

### Male – and female connectors

as per DIN 41612/IEC 60603-2, right angle terminations, view of equipment side

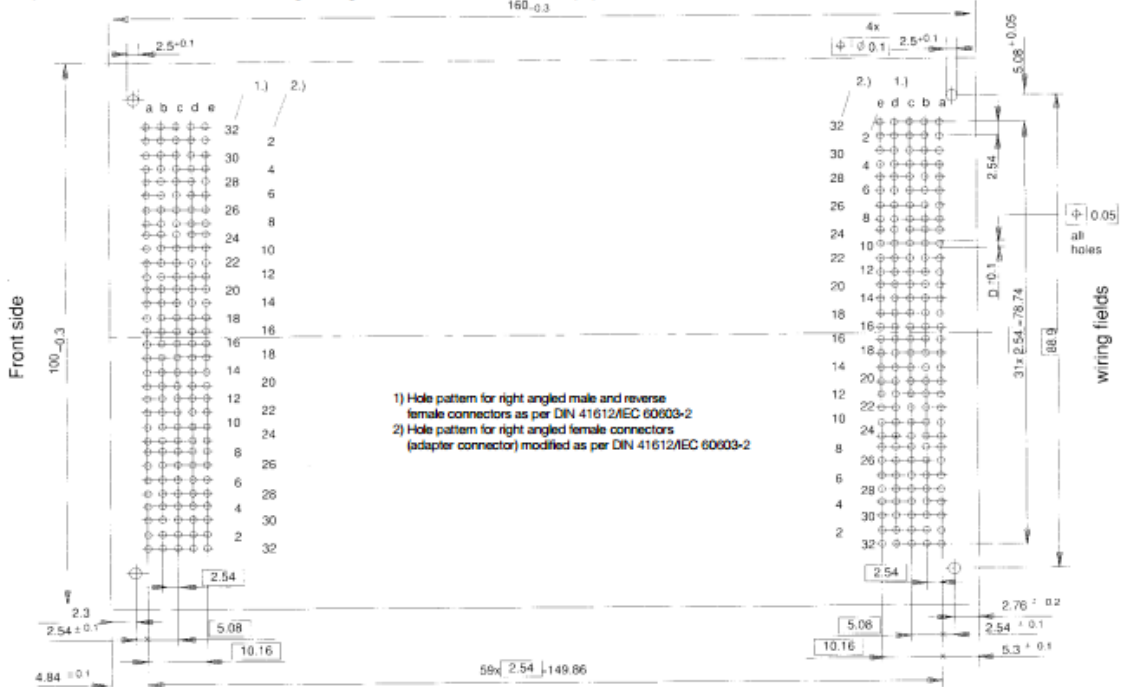

Size	Number of contacts	Rows occupied	Equipped with contacts	D [mm]
B,Q	64	ab	Fully loaded	1.0
B,Q	32	ab	Even numbered	1.0
C,R	96	abc	Fully loaded	1.0
C,R	64	ac	Fully loaded	1.0
C,R,D	32	ac	Even numbered	1.0
E	48	ace	Even numbered	1.0
E	48	abc	Even numbered	1.0
F	48	zbd	Even numbered	1.0
H11	11	e	2,5,8,11...23,26,29,32	1.6
H15	15	bd	b: 4,8,12,16,20,24,28,32 d: 6,10,14,18,22,26,30	1.6
E160, TE160*	160	abcde	Fully loaded	1.0
RD128*	128	abcd	Fully loaded	1.0

\* For the connectors size E160, TE160 and RD128 please refer to the data sheet titled „high-density multi-pin connectors“