



ENGLISH

Product Datasheet

Anti-Vandal Switch

Switch Rotary Selector 19mm Stainless Maintained



RS, Professionally Approved Products, gives you professional quality parts across all products categories. Our range has been testified by engineers as giving comparable quality to that of the leading brands without paying a premium price.



Package Contain:

- 1 x Anti-Vandal Switch
- 1 x Hex Nut
- 1 x O-Ring

ENGLISH

Specification:

SWITCH TYPE:		8771965					
POLES/THROWS:		SPDT					
SWITCH FUNCTIONS:		Illuminated, 90° 2 position ON-ON					
ELECTRICAL CHARACTERISTICS	CONTACT RATING:	Rated insulation voltage (Ui)		250V			
		Thermal current (Ith)		5A Max.			
		Rated voltage		12V	24V	110V	220V
		Rated current	AC 50/60Hz	Resistive load	--	--	1A
	Inductive load			--	--	0.7A	0.5A
	DC	Resistive load	1A	1A	0.2A	--	
		Inductive load	0.7A	0.7A	0.1A	--	
ELECTRICAL LIFE:	50,000 make-and-break cycles at full load						
CONTACT RESISTANCE:	50m-ohms max. initial @ 2-4VDC, 100mA						
INSULATION RESISTANCE:	Apply 500VDC for 1min±5sec. After which measurement to be made b/w terminals shall result 1,000M-ohms min.						
DIELECTRICAL STRENGTH:	1,500VAC (50Hz) RMS @ sea level shall result no damage to parts arcing or flashover						
OPERATING TEMPERATURE:	-20Celsius degree to +55Celsius degree						
RELAIBILITY PERFORMANCE	MECHANICAL LIFE:	Without load, 50,000cycles min.					
	TORQUE:	0.8Nm max. applied to nut					
	PANEL THICKNESS:	1 ~ 10mm					
	IP PROTECTION CLASS:	Front panel protection to IP67					
	IMPACT RESISTANCE:	IK02					
	SOLDERING HEAT RESISTANCE:	Max soldering temperature @ 260Celsius degree, immersion time 5+/-1sec, frequency of soldering process @ 2 times max.					
	COLD TEST:	Stored at temperature -20(+/-3)Celsius degree for 48 hours, shall result no changes to switch's electrical performance					
	HOT TEST:	Stored at temperature +55(+/-3)Celsius degree for 48 hours, shall result no changes to switch's electrical performance					
	HUMIDITY TEST:	Stored at temperature 40(+/-3)Celsius degree with relative humidity 90%~95% for 48 hours, shall result no changes to switch's electrical performance					



ENGLISH

MATERIAL CHARACTERISTICS	BUTTON:	
	BUSHING:	B22 : Stain less steel with varnished polished
	BASE:	PBT
	PLUNGER:	POM
	SPRING:	Steel wire
	CONTACT:	Copper alloy, silver plated
	TERMINALS:	Brass, silver plated
	HARDWARE:	Nut (Brass, nickel plated)
	LED:	Red (AC/DC Compatible) Voltage & Rating: 24V @ 15mA
SOLDERING & CLEANING RECOMMENDATION	HAND SOLDERING:	Max. temperature @ 320Celsius degree (662F)with continuous soldering time @ 2sec. max.
	CLEANING PROCESS:	Noted, the switch is "not totally sealed" so it is important not to immerse/spray or clean unsealed areas of the switch during flux removal. Improper cleaning could cause switch deficiencies such as intermittence or open contact failures
PACKAGE	INTERNAL PACKAGING:	1pcs per PE bag
	RoHS IDENTIFI-CATIONS:	A label marking "RoHS compliant" will be attached to the carton box.

The shaded part is illuminated

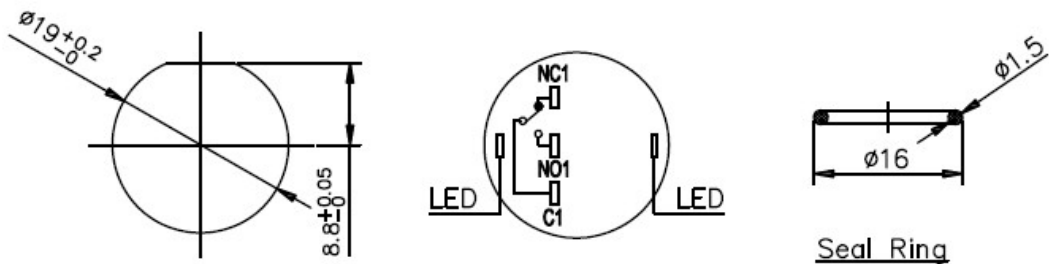
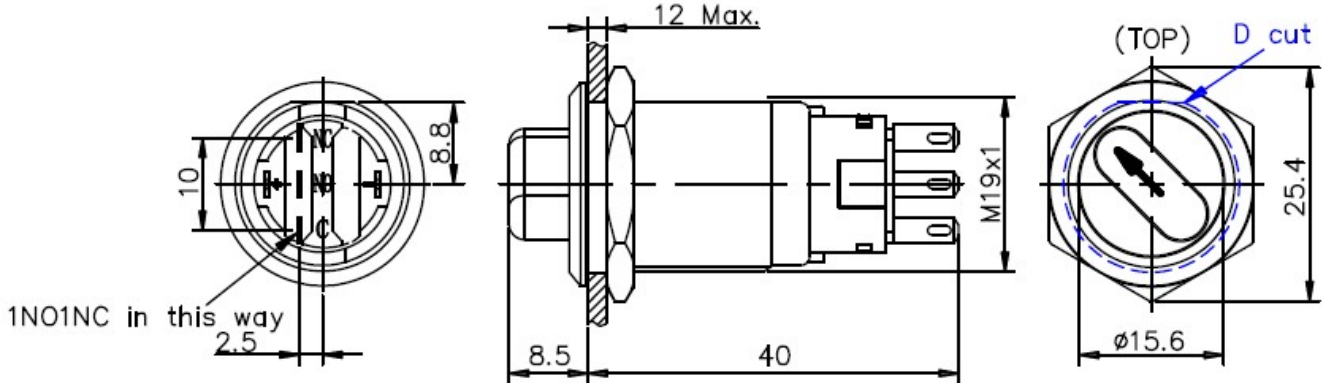

PANEL CUTOUT

CONTACT COMPOSITION

Seal Ring

CONTACT COMPOSITION

Switch Type	90° Two Position
Operation Position	1NO1NC
	NO ϕ NC
	NO ϕ NC