

SPRT®

SP-RME4

Thermal Receipt Printer User's Manual

Ver 1.04

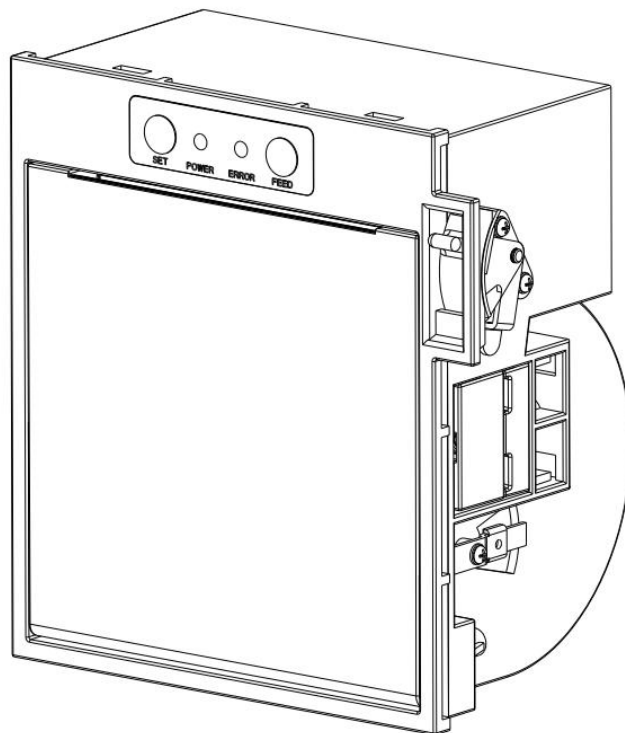

Beijing Spirit Technology Development Co.,Ltd.

www.sprt-printer.com

Content

Introduction.....	1
Chapter 1 Feature and Performance.....	2
1.1 Print Performance.....	2
1.2 Print Paper.....	2
1.3 Print Font.....	2
1.4 Interface.....	3
1.5 Print Control Commands.....	3
1.6 Power Supply.....	3
1.7 Operation Environment.....	3
1.8 Outline Dimension.....	3
Chapter 2 Operation Specification.....	6
2.1 Printer Appearance.....	6
2.2 Installation of the printer.....	7
2.3 Paper Installation.....	8
2.3.1 Paper Loading.....	8
2.3.2 Solution to Paper Jam.....	8
2.4 Interface.....	8
2.4.1 Serial Interface.....	8
2.4.2 USB interface.....	10
2.4.3 Power Connection.....	10
2.5 Indicator Light, Buzzer and Buttons.....	11
2.6 Normally Working Status.....	12
2.7 Self test.....	13
2.8 Hexadecimal Printing.....	13
2.9 Setup of printer parameter.....	14
2.10 Entering program upgrading mode.....	14
APPENDIX A: Parameter Setting.....	15

Introduction

RME4 printer is a new type line thermal printer, which features in fast speed print, low print noise, high reliability, perfect print quality and ribbon needless, avoiding the vexation of regular maintenance.

The RME4 printer is small in size, easy to operate and widely used.

Chapter 1 Feature and Performance

1.1 Print Performance

- Print method: direct thermal
- Print paper width: 79.5±0.5mm/57.5±0.5mm
- Print density: 8 dots/mm, 576 dots/line
- Print speed: max 170mm / sec.
- Reliability
 - (1) Print head life: 100km
Using condition:
 - * Print 12 × 24 ANK characters, print 50 lines each time, intermittent print repeatedly.
 - * Use specified thermal paper.
 - (2)Cutter life: 700,000 cuts
Using condition: less than 30 cuts/minute.
- Valid print width:72/48mm

1.2 Print Paper

- Thermal paper roll model: TF50KS—E(Japan paper co.ltd)
AF50KS-E (JUJO THERMAL)
- Thermal paper roll: Width— — — 79.5±0.5mm/57.5±0.5mm
Outer Diameter — — — 80mm(max.);
Inner Diameter— — — 13mm(min.);
Thickness — — — 0.06mm~0.08mm.

1.3 Print Font

- ANK Character Set:
12×24 dots, 1.5(W)×3.00(H)mm
- GB18030(Chinese):

24×24 dots, 3.00(W)×3.00(H)mm.

1.4 Interface

- RS—232C Serial Interface:

IDC10 socket, supports XON/XOFF and DTR/DSR protocols.

Baud rate:1200, 2400, 4800, 9600, 19200, 38400, 57600, 115200bps adjustable.

Data structure: 1start bit + (7 or 8) data bits + 1 stop bit.

Parity checking: no parity or odd, even parity optional.

- USB Interface:

Mini USB interface

1.5 Print Control Commands

- Character print commands: support double-width, double height print of ANK characters, user-defined characters and Chinese characters, the character line spacing is adjustable.
- Graphics print commands: support the print of bit-map graphics and download bit-map graphics with different density.
- GS bar code print commands: support UPC-A, UPC-E, EAN-13, EAN-8, CODE39, ITF25, CODEBAR, CODE93, CODE128, PDF417, QR code, DATA Matrix bar code print.

1.6 Power Supply

- DC24V±10%, 2A, 2114s-02 power socket.

1.7 Operation Environment

- Operation temperature: -10~50℃; Operation related humidity: 10~80%
- Storage temperature: -20~60℃; Storage related humidity: 10~90%

1.8 Outline Dimension

Weight: 400g(exclude paper roll)

Outline dimension: 132mm×125.5mm×87mm(L x W x H)

Depth:81.5mm

Please check outline dimension in the below figure 1-1:

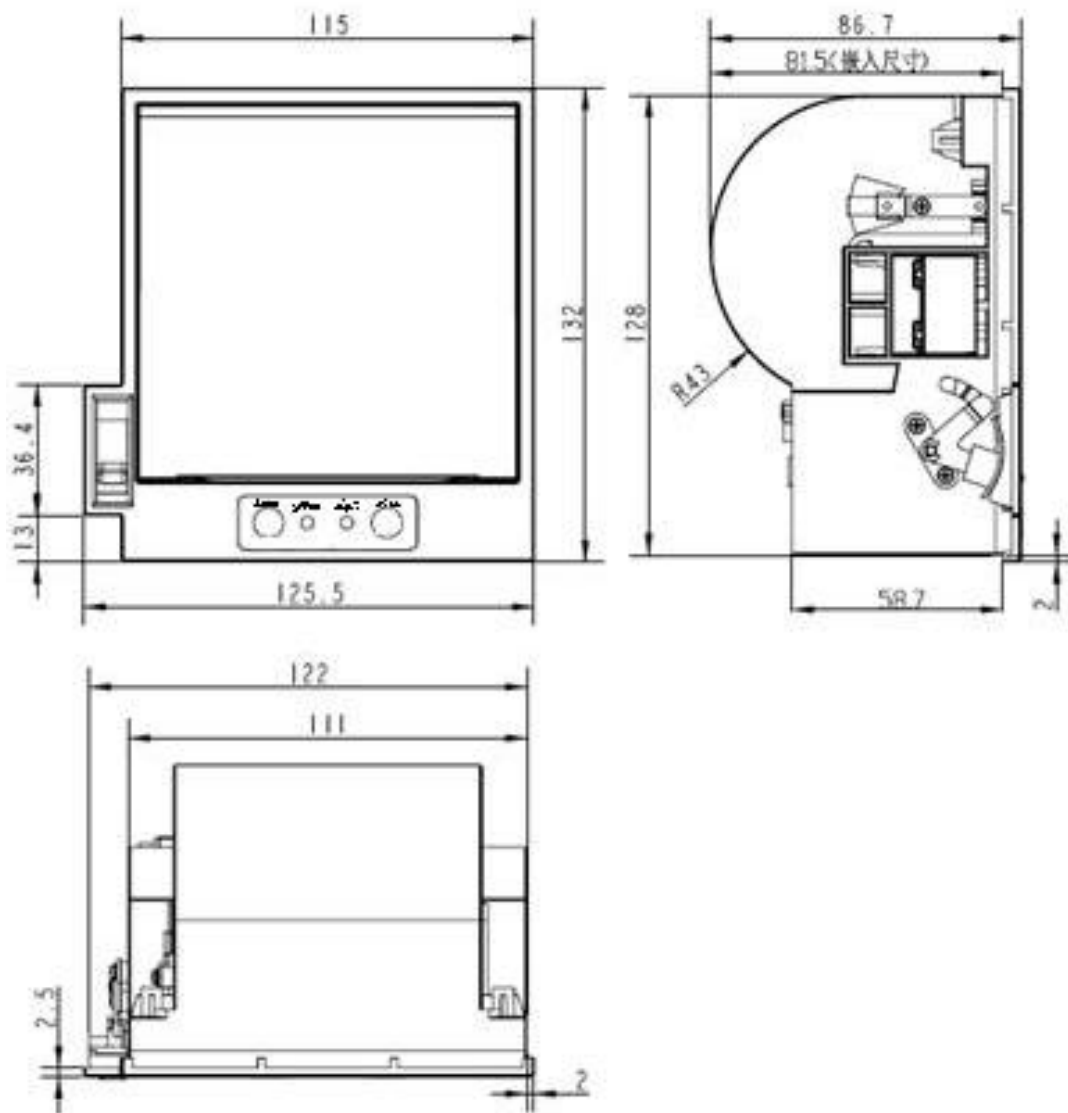

Fig.1-1 SP-RME4 Outline dimension

Installing hole dimension of customer's panel, refer to figure 1-2:

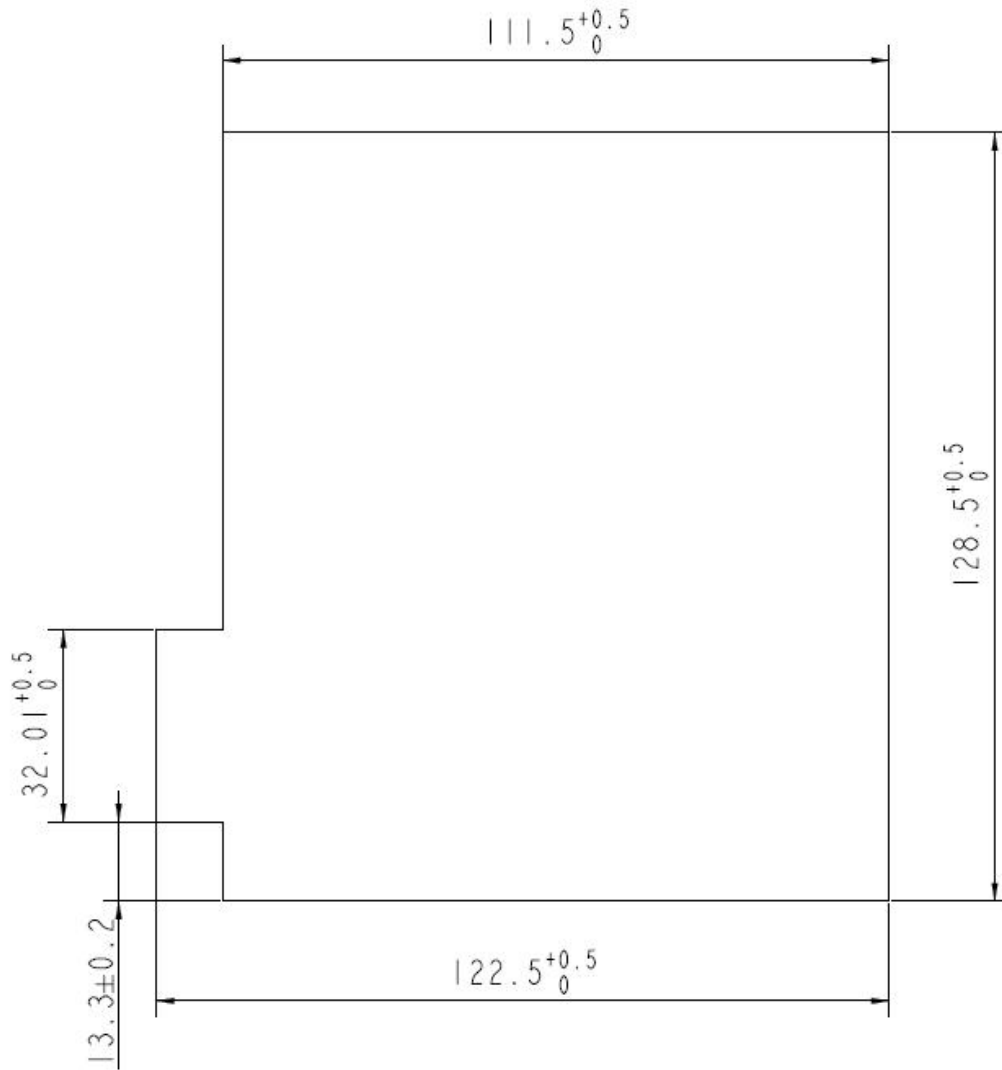
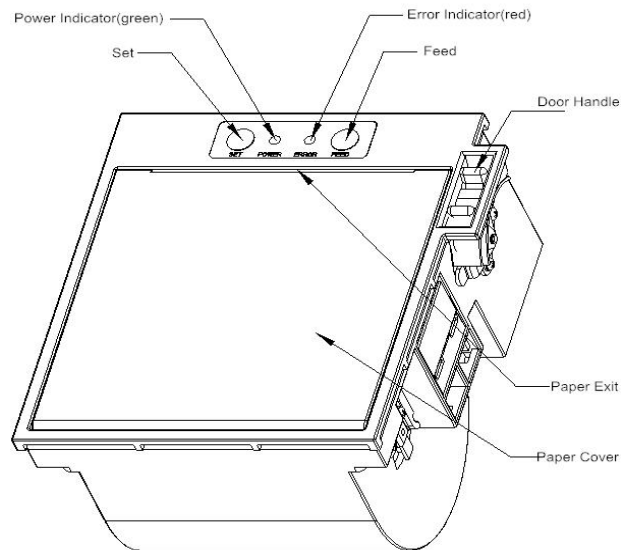

Fig.1-2 SP-RME4 Installation dimension

Chapter 2 Operation Specification

2.1 Printer Appearance

About the name of each part of printer, please refer to figure 2-1:



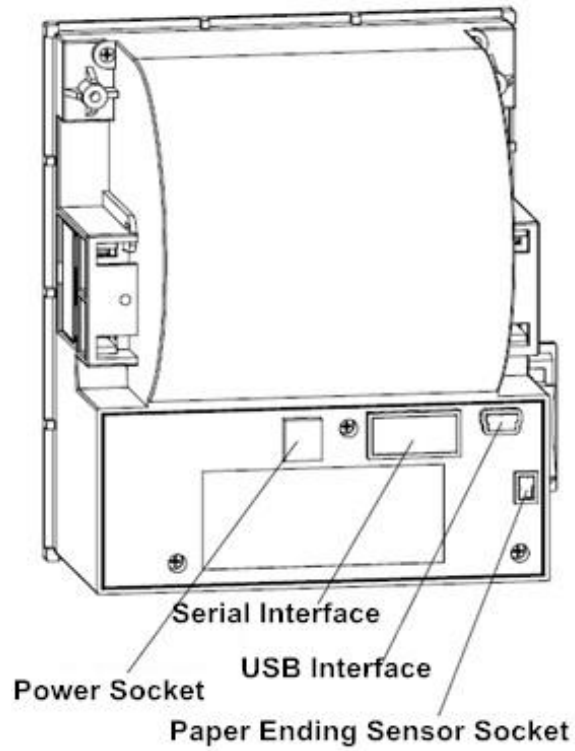

Fig.2-1 Printer Appearance

2.2 Installation of the printer

Embedded printer in the installing hole of customer's panel. open the printer paper cover, clockwise to tighten the two screws to complete the installation of the printer. Please refer to Figure 2-2.

Clockwise rotation

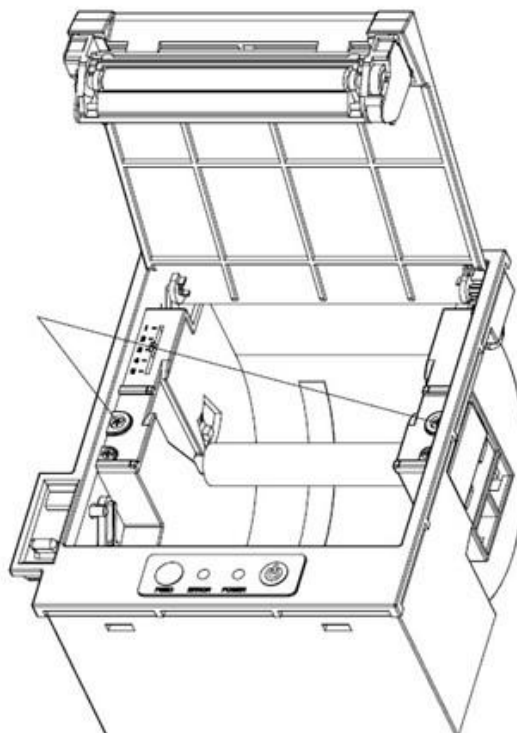

Fig. 2-2 Installing instruction

2.3 Paper Installation

2.3.1 Paper Loading

RME4 adopts 79.5±0.5mm/57.5±0.5mm width thermal paper roll.

Steps of Loading Thermal Paper are as below:

Hold down the upper cover button on the left side, open the movable upper cover, draw a certain length of the paper roll, put the paper end on the print head, close the upper cover and press it downwards lightly.



1. Pay attention to the direction of loading paper, make the printing surface face to the print head.
2. Please don't feed or draw the paper forwards or backwards with hands.
3. Keep clean of the print head, avoid to influence the printing quality.

2.3.2 Solution to Paper Jam

If cutter is jammed, turn off the power, and turn on again, the cutter will be back to original position. If paper jammed, open the paper cover, and take out the paper.

If the cutter can not be back to the original position after power on again, open the paper cover directly, the cutter will be back to original position before the paper cover opening.

2.4 Interface

2.4.1 Serial Interface

The serial interface of SP-RME4 printer is compatible with RS-232C, supports DTR/DSR and XON/XOFF handshaking protocols, uses IDC10 socket. The pin order of the serial port is as Figure 2-3 shows:

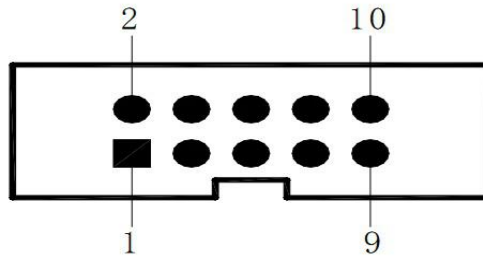

Fig.2-3 Pin Order of Serial Port

The pin assignment of serial interface is shown in Fig. 2-3:

Pin No.	Signal Name	Signal Direction	Source	Description
2	DTR	Output	Printer	Signal "MARK" means the host is busy and can not receive data.Signal "SPACE" means the host is ready to receive data.
3	TXD	Output	Printer	Printer transmits control code X-ON/X-OFF and data to host
4	DSR	Input	Host	Signal "MARK" means the host is busy and can not receive data.Signal "SPACE" means the host is ready to receive data.
5	RXD	Input	Host	Printer receives data from host
6	RTS	Output	Printer	Same with Pin No.2 DTR Signal
9	GND	-----	-----	Signal Ground

Fig. 2-3 The pin assignment of serial interface

Note: (1)"Source" denotes the source that signal come from;

(2)Logical signal level is EIA.

The baud rate and data structure in serial interface mode is 9600bps, 8-bit data bits, no parity bit and 1 stop bit. The serial interface of SP-RME4 can be

connected to standard RS-232C interface. When it is connected to IBM PC or its compatible machine, connection can accord to Fig.2-4.

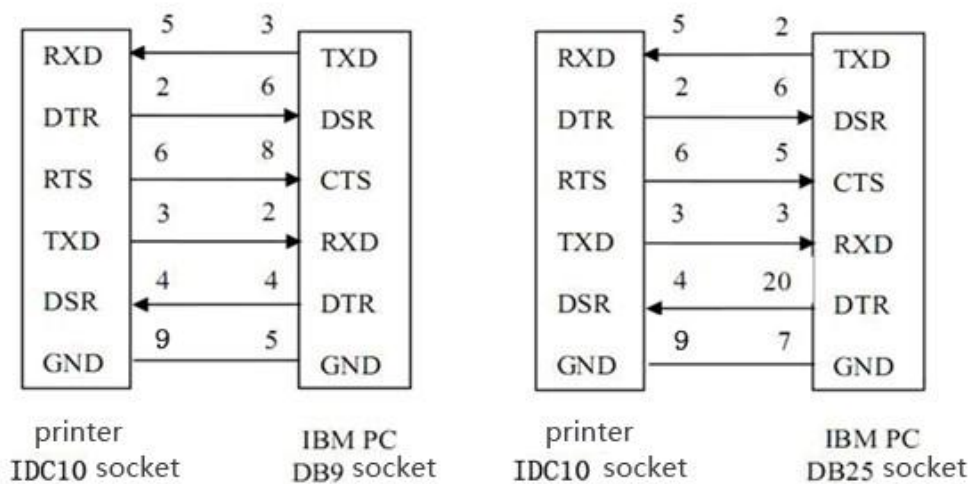

Fig.2-4 Connection between SP-RME4 and IBM PC Serial Interface

2.4.2 USB interface

The USB interface of the RME4 printer is mini-USB interface, outer appearance and pin assignment is shown in Figure 2-5:

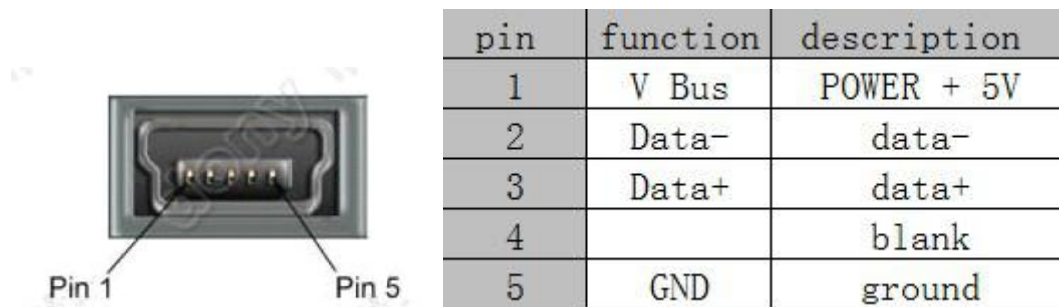

Fig 2-5. Mini-USB socket and pin definitions

2.4.3 Power Connection

SP-RME4 printer uses the external power supply adopter as 24V±10%、2A, power socket is 2114S-02 model, as Fig. 2-6 shows:

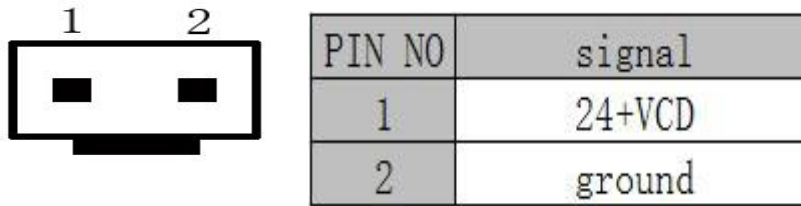

Fig.2-6 Power Socket

2.5 Indicator Light, Buzzer and Buttons

There are two buttons, one inner buzzer and two indicator lights for RME4.

【SET】 is setting button, 【SET】 is used with 【FEED】 button to set parameters. For details, please refer to “2.9 Setup of printer parameter”.

【FEED】 is paper feed button. The function of this button is on/off can be set by print command. When the function of this button is on, press 【FEED】 button to feed paper, release 【FEED】 button to stop feeding button.

The buzzer can indicate the error and cutter status. Through parameters setting, the buzzer can be set into error alarm, paper-cut indicating or both above. The types of error status are same as ERROR indicator.

The green POWER light is the power indicator. POWER indicator lighting means the printer is power on.





The red ERROR light is error status indicator. It is off when the printer works normally; while it flashes or persistently lights when the printer has abnormal alarm. If ERROR indicator flashes or persistent lights and the buzzer sounds, it means the printer has error.

According to different flashing types, the different errors of printer are indicated:

1. Unrecoverable error: the times of indicator flashing and buzzer sound indicate the error type, then indicator persistently light.
2. Recoverable error: the times of indicator flashing and buzzer sound indicate the error type, then indicator is persistently off.
3. Automatically recoverable error: the indicator flashes and the buzzer sounds continuously.
4. Paper out: the indicator lights and the buzzer sounds persistently.

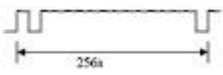
The details are as below:

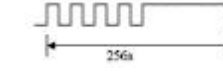
- a. Unrecoverable error, the indicator flashes several times, then persistently lights. Then cycle. The times of flashing means the error type.

Error type	Description	Types of ERROR flashing
Unrecoverable error	LED flashes once : Memory read - write errors	
	LED flashes twice: Over-voltage	
	LED flashes three times: the voltage is lack	
	LED flashes four times : CPU Execution error (wrong address)	
	LED flashes five times : UIB error	
	LED flashes eight times : temperature detection of circuit is wrong	

b. Recoverable error: the indicator continuously flashes and persistent off for a period.

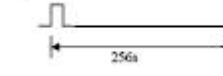
Error type	Prescription	Type of flash
Recoverable error	LED flashes once: the position of cutter is wrong	

c. Automatically recoverable error: the indicator flashes continuously.

Error type	Description	Type of flash
Automatically recoverable error	LED continues flashing: the temperature of printing head is overheat and the cover is wrong	

2.6 Normally Working Status

When the printer is off and paper case cover is closed, press the POWER button to turn on the printer and the ERROR indicator flashes twice, then indicator light off. The printer enters into the normal working mode.

2.7 Self test

The self-test will check the condition of printer, if the printer prints out the self-test receipt correctly, it means the printer works normally. Otherwise it needs to be repaired.

The self-test will print out: Manufacturer name, printer model, software version, interface type, default value of printer parameters, 96 ANK characters in ASCII code, content of default codepage (if language is set English) or name of Chinese character library (if the language is set Chinese), barcode type.

Way of self-test: Press **【FEED】** button, then power on the printer. Printer will print out self-test receipt. The content is as below picture 2-7:



Fig. 2-7

2.8 Hexadecimal Printing

Turn on the printer according to the step below, it will enter the mode of Hexadecimal Printing.

1. Press **【SET】** button persistently and power on;
2. Press **【FEED】** button once and release both **【SET】** and **【FEED】** buttons.

The printer will print out 3 lines as below:

Hexadecimal Dump

To terminate hexadecimal dump,
Press FEED button three times.

This means the printer has entered hexadecimal printing mode, and under this mode, all of the input will be printed out as hexadecimal number. Paper will feed one line with single-click of “FEED” button, after 3 times, it will print out “*** Completed ***”, and exit hexadecimal printing mode.

2.9 Setup of printer parameter

This function is for the setup of parameters.

Steps for setting parameters: Power off, press **【SET】** button and power on, do not release **【SET】** and press **【FEED】** button twice and then release all the buttons; printer enters in parameter setting mode. Printer will print the first parameter which can be set and its current setup; Details can be checked on attached Appendix.

Steps for exiting of parameter setup: Press **【SET】** button and then press **【FEED】** button; release **【SET】** and **【FEED】** button at the same time to save the setup of parameter and exit, the printer will enter into normal mode.

If power off directly, the parameters will not be saved.

2.10 Entering program upgrading mode

When printer power is off, open paper case cover, press **【FEED】** button, then power on. After hearing the buzzer “one low one high” sound, release **【FEED】** button. Printer enters into the program upgrading mode. At this time, the indicator flashes once each second.

Notice: Both serial interface and USB interface can support program upgrading online.

APPENDIX A: Parameter Setting

This appendix is the method of setting default parameters of printer by buttons. Setting instruction: Using **【SET】** button to choose setting item. Pressing this button once, the setting item will go to the next and also print out the current value of this item. Using **【FEED】** button to choose the setting value of item. Press the button once, the setting value will go to the next.

Summary setting:

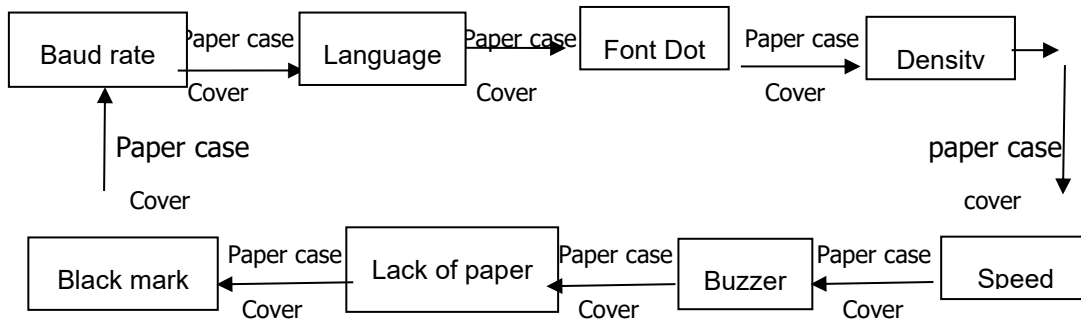

Baud rate:

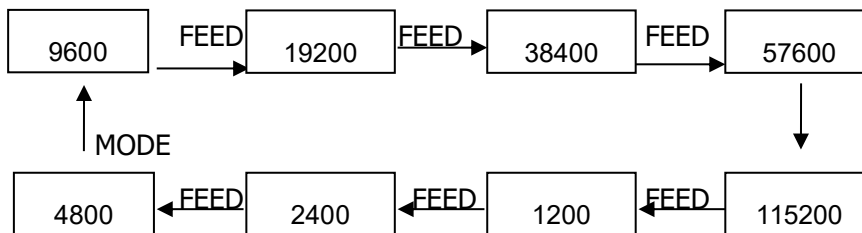

Language:

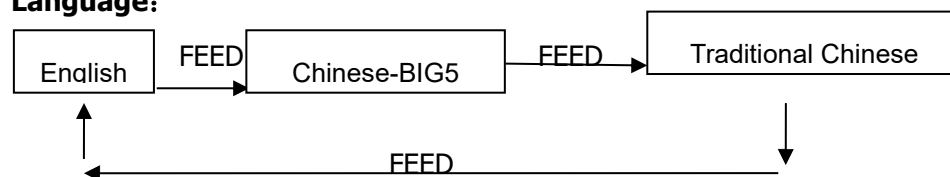

Font:

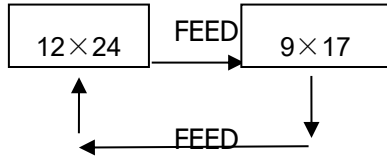

Density:

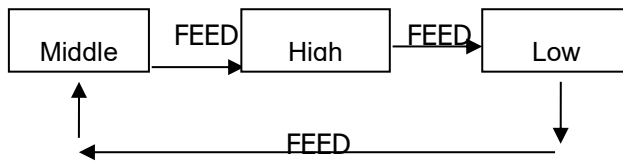

Buzzer:

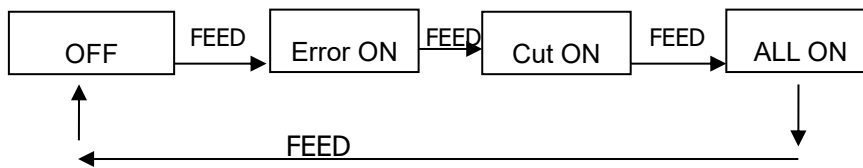

Print lack of paper:

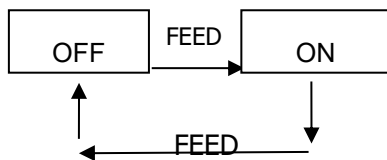

Black mark:

